ROBOTICS

Product manual

IRB 6650S



Trace back information:

Workspace 23B version a12 (not checked in)

Published 2023-06-21 at 15:42:40

Skribenta version 5.5.019

Product manual

IRB 6650S - 200/3.0
IRB 6650S - 190/3.0 LID
IRB 6650S - 125/3.5
IRB 6650S - 100/3.5 LID
IRB 6650S - 90/3.9

IRC5, OmniCore

Document ID: 3HAC020993-001

Revision: AK

The information in this manual is subject to change without notice and should not be construed as a commitment by ABB. ABB assumes no responsibility for any errors that may appear in this manual.

Except as may be expressly stated anywhere in this manual, nothing herein shall be construed as any kind of guarantee or warranty by ABB for losses, damage to persons or property, fitness for a specific purpose or the like.

In no event shall ABB be liable for incidental or consequential damages arising from use of this manual and products described herein.

This manual and parts thereof must not be reproduced or copied without ABB's written permission.

Keep for future reference.

Additional copies of this manual may be obtained from ABB.

Original instructions.

© Copyright 2004-2023 ABB. All rights reserved.
Specifications subject to change without notice.

Table of contents

Overview of this manual	9
Product documentation	17
How to read the product manual	19
1 Safety	21
1.1 Safety information	21
1.1.1 Limitation of liability	21
1.1.2 Requirements on personnel	22
1.2 Safety signals and symbols	23
1.2.1 Safety signals in the manual	23
1.2.2 Safety symbols on manipulator labels	25
1.3 Robot stopping functions	31
1.4 Safety during installation and commissioning	32
1.5 Safety during operation	35
1.6 Safety during maintenance and repair	36
1.6.1 Safety during maintenance and repair	36
1.6.2 Emergency release of the robot axes	39
1.6.3 Brake testing	40
1.7 Safety during troubleshooting	41
1.8 Safety during decommissioning	42
2 Installation and commissioning	43
2.1 Introduction to installation and commissioning	43
2.2 Unpacking	44
2.2.1 Pre-installation procedure	44
2.2.2 Technical data	45
2.2.3 Working range and type of motion	49
2.2.4 Risk of tipping/stability	53
2.2.5 The unit is sensitive to ESD	54
2.3 On-site installation	55
2.3.1 Lifting robot with fork lift	55
2.3.2 Lifting robot with roundslings	60
2.3.3 Lifting robot with lifting accessory (recommended lifting method)	62
2.3.4 Manually releasing the brakes	64
2.3.5 Lifting the base plate	66
2.3.6 Securing the base plate	67
2.3.7 Orienting and securing the robot	72
2.3.8 Fitting equipment on robot	75
2.3.9 Safety lamp (option for IRC5)	81
2.3.10 Installation of base spacers (option)	82
2.3.11 Installation of cooling fan for motors (option)	84
2.3.12 Installation of option Foundry cable guard	91
2.3.13 Loads fitted to the robot, stopping time and braking distances	92
2.4 Restricting the working range	93
2.4.1 Axes with restricted working range	93
2.4.2 Mechanically restricting the working range of axis 1	94
2.4.3 Extended working range, axis 1 (option)	96
2.4.4 Mechanically restricting the working range of axis 2	98
2.4.5 Mechanically restricting the working range of axis 3	100
2.5 Electrical connections	103
2.5.1 Robot cabling and connection points	103
2.6 Start of robot in cold environments	107
2.7 Test run after installation, maintenance, or repair	108
3 Maintenance	109
3.1 Introduction	109

3.2	Maintenance schedule and expected component life	110
3.2.1	Specification of maintenance intervals	110
3.2.2	Maintenance schedule	111
3.2.3	Expected component life	114
3.3	Inspection activities	115
3.3.1	Inspecting the motor seal	115
3.3.2	Inspecting the oil level in axis-1 gearbox	117
3.3.3	Inspecting the oil level in axis-2 gearbox	119
3.3.4	Inspecting the oil level in axis-3 gearbox	121
3.3.5	Inspecting the oil level in axis-4 gearbox	124
3.3.6	Inspecting the oil level in axis-5 gearbox	126
3.3.7	Inspecting the oil level in axis-6 gearbox	128
3.3.8	Inspecting the balancing device	133
3.3.9	Inspecting the cable harness	138
3.3.10	Inspecting the information labels	142
3.3.11	Inspecting the axis-1 mechanical stop pin	144
3.3.12	Inspecting the additional mechanical stops	146
3.3.13	Inspecting the damper on axes 2-5	149
3.3.14	Inspecting, signal lamp	151
3.4	Replacement/changing activities	153
3.4.1	Type of lubrication in gearboxes	153
3.4.2	Changing oil, axis-1 gearbox	155
3.4.3	Changing oil, axis-2 gearbox	158
3.4.4	Changing oil, axis-3 gearbox	161
3.4.5	Changing oil, axis-4 gearbox	164
3.4.6	Changing oil, axis-5 gearbox	167
3.4.7	Changing oil, axis-6 gearbox	170
3.4.8	Replacing the SMB battery	173
3.5	Lubrication activities	177
3.5.1	Lubrication of spherical roller bearing, balancing device	177
3.6	Cleaning activities	179
3.6.1	Cleaning the IRB 6650S	179
4	Repair	183
4.1	Introduction	183
4.2	General procedures	184
4.2.1	Performing a leak-down test	184
4.2.2	Mounting instructions for bearings	185
4.2.3	Mounting instructions for sealings	187
4.2.4	Cut the paint or surface on the robot before replacing parts	190
4.2.5	The brake release buttons may be jammed after service work	191
4.3	Complete robot	192
4.3.1	Replacing cable harness, axes 1-6	192
4.3.2	Replacement of cable harness, axes 1-4	208
4.3.3	Replacement of cable harness, axes 5-6	218
4.3.4	Replacement of cabling, axis 5 motor	223
4.3.5	Replacement of complete arm system	225
4.4	Upper and lower arm	231
4.4.1	Replacing the turning disk	231
4.4.2	Replacement of complete wrist unit	235
4.4.3	Replacement of upper arm	241
4.4.4	Replacement of complete lower arm	250
4.4.5	Replacement of lower arm shaft	260
4.4.6	Securing the lower arm	268
4.5	Frame and base	272
4.5.1	Replacing the SMB unit	272
4.5.2	Replacing the brake release board	275
4.5.3	Replacement of spherical roller bearing, balancing device	279

4.5.4	Replacement of balancing device	282
4.5.4.1	Replacing the balancing device	282
4.6	Motors	294
4.6.1	Replacement of motor, axis 1	294
4.6.2	Replacement of motor axis 2	299
4.6.3	Replacement of motor, axis 3	305
4.6.4	Replacement of motor, axis 4	311
4.6.5	Replacement of motor, axis 5	316
4.6.6	Replacement of motor, axis 6	322
4.7	Gearboxes	328
4.7.1	Replacing the axis 1 gearbox	328
4.7.2	Replacement of gearbox axis 2	339
4.7.3	Replacement of gearbox, axis 3	346
4.7.4	Replacement of gearbox, axis 6	353
5	Calibration	359
5.1	Introduction to calibration	359
5.1.1	Introduction and calibration terminology	359
5.1.2	Calibration methods	360
5.1.3	When to calibrate	363
5.2	Synchronization marks and axis movement directions	364
5.2.1	Synchronization marks and synchronization position for axes	364
5.2.2	Calibration movement directions for all axes	365
5.3	Updating revolution counters	366
5.3.1	Updating revolution counters on IRC5 robots	366
5.3.2	Updating revolution counters on OmniCore robots	370
5.4	Calibrating with Axis Calibration method	372
5.4.1	Description of Axis Calibration	372
5.4.2	Calibration tools for Axis Calibration	375
5.4.3	Installation locations for the calibration tools	377
5.4.4	Axis Calibration - Running the calibration procedure	378
5.4.5	Reference calibration	382
5.5	Calibrating with Wrist Optimization method	384
5.6	Verifying the calibration	386
5.7	Checking the synchronization position	387
6	Decommissioning	389
6.1	Introduction to decommissioning	389
6.2	Environmental information	390
6.3	Scrapping of robot	392
6.4	Decommissioning of balancing device	393
7	Robot description	395
7.1	Type A vs type B motors	395
8	Spare part lists	397
8.1	Spare part lists and illustrations	397
9	Reference information	399
9.1	Introduction	399
9.2	Applicable standards	400
9.3	Unit conversion	401
9.4	Screw joints	402
9.5	Weight specifications	405
9.6	Standard tools	406
9.7	Special tools	407
9.8	Lifting accessories and lifting instructions	410

Table of contents

10 Circuit diagram	411
10.1 Circuit diagrams	411
10.2 Circuit diagram 3HAC 025744-001	413
10.2.1 Validity of circuit diagram 3HAC025744-1	413
10.3 Circuit diagram 3HAC 13347-1	414
10.3.1 Validity of circuit diagram 3HAC13347-1	414
Index	415

Overview of this manual

About this manual

This manual contains instructions for:

- mechanical and electrical installation of the robot
- maintenance of the robot
- mechanical and electrical repair of the robot.

The manual also contains reference information for all procedures detailed in the manual.

The robot described in this manual has the protection type Standard and Foundry Plus.

Usage

This manual should be used during:

- installation, from lifting the robot to its work site and securing it to the foundation to making it ready for operation
 - maintenance work
 - repair work.
-

Who should read this manual?

This manual is intended for:

- installation personnel
 - maintenance personnel
 - repair personnel.
-

Prerequisites

Maintenance/repair/installation personnel working with an ABB Robot must:

- be trained by ABB and have the required knowledge of mechanical and electrical installation/repair/maintenance work.
-

Product manual scope

The manual covers covers all variants and designs of the IRB 6650S. Some variants and designs may have been removed from the business offer and are no longer available for purchase.

Organization of chapters

The manual is organized in the following chapters:

Chapter	Contents
Safety	Safety information that must be read through before performing any installation or service work on robot. Contains general safety aspects as well as more specific information about how to avoid personal injuries and damage to the product.
Installation and commissioning	Required information about lifting and installation of the robot.

Continues on next page

Overview of this manual

Continued

Chapter	Contents
Maintenance	Step-by-step procedures that describe how to perform maintenance of the robot. Based on a maintenance schedule that may be used in the work of planning periodical maintenance.
Repair	Step-by-step procedures that describe how to perform repair activities of the robot. Based on available spare parts.
Calibration	Calibration procedures and general information about calibration.
Decommissioning	Environmental information about the robot and its components.
Reference information	Useful information when performing installation, maintenance or repair work. Includes lists of necessary tools, additional documents, safety standards etc.
Spare part / Part list	Complete spare part list and complete list of robot components, shown in the exploded views.
Exploded views	Detailed illustrations of the robot with reference numbers to the part list.
Circuit diagram	Reference to the circuit diagram for the robot.

References

General

Document name	Document ID
<i>Product manual, spare parts - IRB 6650S</i>	<i>3HAC049111-001</i>
Circuit diagram	<i>3HAC13347-1</i> <i>3HAC025744-001</i>
<i>Product manual - DressPack/SpotPack IRB 6650S</i>	<i>3HAC055424-001</i>
<i>Technical reference manual - Lubrication in gearboxes</i>	<i>3HAC042927-001</i>
<i>Safety manual for robot - Manipulator and IRC5 or OmniCore controllerⁱ</i>	<i>3HAC031045-001</i>

ⁱ This manual contains all safety instructions from the product manuals for the manipulators and the controllers.

OmniCore robots

Document name	Document ID
<i>Product specification - IRB 6650S</i>	<i>3HAC081956-001</i>
<i>Product manual - OmniCore V250XT Type A</i>	<i>3HAC084692-001</i>
<i>Product manual - OmniCore V250XT</i>	<i>3HAC073447-001</i>
<i>Operating manual - OmniCore</i>	<i>3HAC065036-001</i>
<i>Technical reference manual - System parameters</i>	<i>3HAC065041-001</i>

IRC5 robots

Document name	Document ID
<i>Product specification - IRB 6650S</i>	<i>3HAC030822-001</i>
<i>Product manual - IRC5</i> IRC5 with main computer DSQC 639.	<i>3HAC021313-001</i>

Continues on next page

Document name	Document ID
<i>Product manual - IRC5</i> IRC5 with main computer DSQC1000.	3HAC047136-001
<i>Operating manual - IRC5 with FlexPendant</i>	3HAC050941-001
<i>Operating manual - Calibration Pendulum</i>	3HAC16578-1
<i>Operating manual - Service Information System</i>	3HAC050944-001
<i>Technical reference manual - System parameters</i>	3HAC050948-001
<i>Application manual - Additional axes and standalone controller</i>	3HAC051016-001
<i>Application manual - CalibWare Field</i>	3HAC030421-001

Revisions

Revision	Description
-	First edition.
A	<ul style="list-style-type: none"> Model M2004 implemented. Product manual divided into two parts: <i>Product manual, procedures</i> and <i>Product manual, reference information</i>. New foldouts: See <i>Frame - lower arm 1</i> and <i>Frame - lower arm 2</i> in <i>Product manual, spare parts - IRB 6650S</i>. Updated list with special tools, section Special tools on page 407. Added spare part list, new section <i>Spare part list</i> in <i>Product manual, spare parts - IRB 6650S</i>. <p>Various corrections and editing made in text and figures due to technical revisions etc.</p>
B	Chapter <i>Calibration</i> replaced with chapter <i>Calibration information</i> . Section <i>Document references</i> is completed with article numbers for calibration manuals.
C	New lubricating oil in the gearboxes, axes 1, 2, 3 and 6. Changes made in: <ul style="list-style-type: none"> chapter Maintenance on page 109. This is detailed in section Spare part lists on page 397.
D	<ul style="list-style-type: none"> Article number for mechanical stop set added to section Mechanically restricting the working range of axis 2 on page 98. New section added to the manual: Installation of cooling fan for motors (option) on page 84. A complete (undivided) cabling from axis 1 to axis 6 is added to the spare parts in Spare part lists on page 397. New procedure Replacing cable harness, axes 1-6 on page 192. Also a new circuit diagram is added to the manual, due to the new cabling. IRB 6650S included in section <i>Rebuilding parts</i> in <i>Product manual, spare parts - IRB 6650S</i>.
E	<ul style="list-style-type: none"> New variant IRB 6650S - 90/3.9 is implemented throughout the manual.
F	Foundry Prime Option included.
G	Changes made in: <ul style="list-style-type: none"> Prerequisites in section Overview Oil change in section Maintenance
H	This revision includes the following additions and/or changes: <ul style="list-style-type: none"> The product name RobotStudio Online is changed to <i>RobotStudio</i>. Section "WARNING! - Mixed oils may cause severe damage to gearboxes" in chapter Safety, has been integrated in section "<i>Type of oil in gearboxes</i>" in the Maintenance chapter.

Continues on next page

Revision	Description
	<ul style="list-style-type: none"> • The oil Shell Tivela S150 in gearboxes 1, 2, 3 and 6 has been replaced by <i>Kyodo Yushi TMO 150</i>. Changes in chapters <i>Maintenance</i> and <i>Spare parts</i>. • Modified maintenance intervals for oil change in gearboxes. • Wrong illustration has been replaced by the correct one in "<i>Analysis of water content in oil, gearbox axis 6 (Foundry Prime)</i>", section <i>Inspection, oil level gearbox axis 6</i> chapter maintenance. • The section "<i>Type of oil in gearboxes</i>" in chapter <i>Maintenance</i> has been updated according to changes made in oil types and intervals for oil change. • Values for tightening torque on M24 screws in chapter <i>Reference information</i>, added. • <i>Maintenance/Cleaning of robot</i> • <i>Maintenance/Maintenance schedule</i>: Interval for replacement of battery pack changed • <i>Maintenance/Maintenance schedule</i>: Intervals for inspection activities and oilchanges has been revised. • <i>Maintenance/Maintenance schedule</i>: Overhaul of robot is new. • <i>Maintenance/Maintenance schedule</i>: The information about <i>Service Information System (SIS)</i> has been updated. • <i>Maintenance/Expected component life</i>: The lifetime of certain parts has been revised. • Section <i>What is an emergency stop?</i> added to chapter <i>Safety</i>.
J	<p>This revision include the following addition:</p> <ul style="list-style-type: none"> • New WARNING! added in <i>Safety chapter</i> section <i>Work inside the robot's range</i>. • New WARNING! added in <i>Safety chapter</i> section <i>WARNING! - Safety risks during work with gearbox oil</i>. • The text in the introductions to chapters <i>Installation</i>, <i>Maintenance</i> and <i>Repair</i> has been updated concerning the robot being connected to earth when power connected. • Section <i>Expected component life</i> in chapter <i>Maintenance</i>: The lifetime of certain parts has been updated. • Section <i>Foundry Plus, Cable guard</i> added to <i>Installation chapter</i>.
K	<p>This revision includes the following additions and/or changes:</p> <ul style="list-style-type: none"> • Instruction for how to inspect oil level for wrist type 2 added, see Inspecting the oil level in axis-6 gearbox on page 128. • Circuit diagrams are not included in this document but delivered as separate files. See Circuit diagram on page 411. • List of standards updated, see Applicable standards on page 400. • Interval changed for <i>inspection</i> and <i>lubrication</i> of balancing device (Foundry Prime). See chapter <i>Maintenance</i> section Maintenance schedule on page 111. <p>The chapter <i>Safety</i> updated with:</p> <ul style="list-style-type: none"> • Updated safety signal graphics for the levels <i>Danger</i> and <i>Warning</i>, see Safety signals in the manual on page 23. • New safety labels on the manipulators, see Safety symbols on manipulator labels on page 25. • Revised terminology: <i>robot</i> replaced with <i>manipulator</i>.
L	<p>This revision includes the following updates:</p> <ul style="list-style-type: none"> • Maximum deviation changed, see Securing the base plate on page 67. • New washer, see Replacement of upper arm on page 241. • Corrected spare part numbers.

Revision	Description
M	<p>This revision includes following additions and/or changes:</p> <ul style="list-style-type: none"> • Removed information about lubricating attachment screws, section Inspecting the additional mechanical stops on page 146. • New safety labels on the manipulators, see Safety symbols on manipulator labels on page 25. • Removed incorrect article number for fork lift, see Lifting robot with fork lift on page 55. • Minor adjustments made in the text concerning counters in section <i>Service Information System, M2000</i>. • Footnote about ambient temperature in maintenance schedule is deleted, see Maintenance schedule on page 111. • Information about restricting and extending the working range of axis 1 is now separated, see Mechanically restricting the working range of axis 1 on page 94 and the new section Extended working range, axis 1 (option) on page 96. Also added signal about option 561-1 in section Inspecting the axis-1 mechanical stop pin on page 144. • Removed information about other robots than IRB 6650S from tables for oil type and amount in gearboxes, see Type of lubrication in gearboxes on page 153.
N	<p>This revision includes the following updates:</p> <ul style="list-style-type: none"> • A new block, about general illustrations, added in section How to read the product manual on page 19. • Removed all information about Foundry Prime from the manual. • Adjusted the forces on foundation, see Loads on foundation, robot on page 46. • Added figures for installed position switches on axes 2 and 3 and attachment plate on axis 2. • Made minor corrections and improvements in the complete instruction for how to replace the axis 1 gearbox, see Replacing the axis 1 gearbox on page 328. • Added new mechanical structure of the lower arm attachment point for robots with protection Foundry Plus and Foundry Prime, see Replacement of complete lower arm on page 250 and Replacement of lower arm shaft on page 260. • Some general tightening torques have been changed/added, see updated values in Screw joints on page 402. • Added information about batteries. • The maximum allowed deviation in levelity of the base plate is changed, see Securing the base plate on page 67. • Corrected the article number for mechanical stops of axis 2, see Mechanically restricting the working range of axis 2 on page 98 and Inspecting the additional mechanical stops on page 146. • Reference to Hilti standard added to the foundation recommendation for the base plate and class designation for foundation is changed to european standard C25/C30 (previously Swedish standard K25/K30), see Securing the base plate on page 67. • All data about type of lubrication in gearboxes is moved from the manual to a separate lubrication manual, see Type and amount of oil in gearboxes on page 153. • Corrected the method of inspecting oil level in the axis-6 gearbox, see Inspecting the oil level in axis-6 gearbox on page 128. • Removed information about serrated lock washers from procedure Replacement of complete arm system on page 225. • Corrected type of screws in <i>Base incl frame ax 1</i>, see <i>Product manual, spare parts - IRB 6650S</i> and Replacement of complete arm system on page 225.

Continues on next page

Revision	Description
P	This revision includes the following updates: <ul style="list-style-type: none"> A new SMB unit and battery is introduced, with longer battery lifetime.
Q	This revision includes the following updates: <ul style="list-style-type: none"> Added information about risks when scrapping a decommissioned robot, see Scrapping of robot on page 392. <i>Spare parts and exploded views</i> are not included in this document but delivered as a separate document. See <i>Product manual, spare parts - IRB 6650S</i>.
R	This revision includes the following updates: <ul style="list-style-type: none"> The maximum allowed deviation in levelness of the base plate and foundation is changed, see Securing the base plate on page 67. Minor corrections.
S	This revision includes the following updates: <ul style="list-style-type: none"> New standard calibration method introduced (Axis Calibration). See Calibration on page 359. Tightening torque for securing screw in piston shaft front eye changed, see Replacing the balancing device on page 282. Turning disk fixture is removed from special tools for Levelmeter calibration.
T	This revision includes the following updates: <ul style="list-style-type: none"> Edited information regarding deciding calibration routine in each repair section. Added information about inspection of calibration tool prior to usage, see Examining the calibration tool on page 375. Added a warning that calibration pin must be inserted in the calibration bushing until it snaps, see Description of Axis Calibration on page 372. Added warning regarding risk of pinching, in Description of Axis Calibration on page 372. Added information about Axis Calibration when SafeMove is installed, see Axis Calibration with SafeMove option on page 380. Added information about the calibration procedure, see Overview of the calibration procedure on the FlexPendant on page 378, Restarting an interrupted calibration procedure on page 380.
U	Published in release R16.2. The following updates are done in this revision: <ul style="list-style-type: none"> Drawing of base plate is not available for purchase, faulty information removed in Securing the base plate on page 67. Drawing of tool flange for LeanID added. Added spare part number for protection cover and plug set (Axis Calibration).
V	Published in release R17.1. The following updates are made in this revision: <ul style="list-style-type: none"> Removed article number for press fixture (for pressing the pinion of the axis-5 motor). The fixture is not sold by ABB.
W	Published in release R17.2. The following updates are made in this revision: <ul style="list-style-type: none"> Caution about removing metal residues added in sections about SMB boards. Information about minimum resonance frequency added. Bending radius for static floor cables added. Added screw, Loctite, tightening torque and washer for wrist cover. (Tightening torque: 14 Nm±10%, Screw 3HAB3409-25 (with Loctite), Washer 3HAC062379-001.) Updated list of applicable standards. Added text regarding overhaul in section specification of maintenance intervals. Section Start of robot in cold environments on page 107 added.

Continues on next page

Revision	Description
	<ul style="list-style-type: none"> Updated information regarding replacement of brake release board. Updated information regarding disconnecting and reconnecting battery cable to serial measurement board. Definition of reference calibration clarified.
X	<p>Published in release R18.1. The following updates are made in this revision:</p> <ul style="list-style-type: none"> Information added about fatigue to Axis Calibration tool, see Calibration tools for Axis Calibration on page 375. Updated information about locking liquid in Replacement of cable harness, axes 1-4. Added sections in General procedures on page 184. Safety restructured. Updated spare part number brake release board (was DSQC563). Note added to calibration chapter to emphasize the requirement of equally dressed robot when using previously created reference calibration values. Information about myABB Business Portal added. Added Nickel in Environmental information. Type B motors are introduced throughout the manual. <ul style="list-style-type: none"> New periodic maintenance activity regarding inspection of the type B motor oil seal. New gasket at axis-6 motor cable inlet. Changed direction of installed cooling fan on axis-2 motor and removed a faulty image showing the design of the cooling fan. Also added detailed images to installation procedure for the fan.
Y	<p>Published in release R18.2. The following updates are made in this revision:</p> <ul style="list-style-type: none"> New dimensions added on illustration, see Illustration, fitting of extra equipment on frame on page 78.
Z	<p>Published in release R18.2. The following updates are made in this revision:</p> <ul style="list-style-type: none"> Updated references.
AA	<p>Published in release 19B. The following updates are made in this revision:</p> <ul style="list-style-type: none"> New touch up color Graphite White available. See Cut the paint or surface on the robot before replacing parts on page 190. Levelmeter 2000 kit (6369901-347) no longer available.
AB	<p>Published in release 19D. The following updates are made in this revision:</p> <ul style="list-style-type: none"> Added references to DressPack manual in Robot cabling and connection points on page 103.
AC	<p>Published in release 20B. The following updates are made in this revision:</p> <ul style="list-style-type: none"> Clarified and added information in mounting instructions for rotating sealings, see Mounting instructions for sealings on page 187. Clarified text about position of robot and added table with dependencies between axes during Axis Calibration. Added information about Wrist Optimization in calibration chapter. Replaced article number and name of grease, previously 3HAB3537-1. Updated spare part number for axis 1-6 cable harness.
AD	<p>Published in release 20C. The following updates are made in this revision:</p> <ul style="list-style-type: none"> New press equipment introduced for following repair procedures. New article numbers added. User instructions for the equipment are enclosed with the tool and removed from this manual. <ul style="list-style-type: none"> unloading balancing device replacing lower arm shaft replacing balancing device shaft

Continues on next page

Revision	Description
AE	Published in release 21A. The following updates are made in this revision: <ul style="list-style-type: none">• Added information about velcro strap and linear guide for new axis-1-6 cable harness.
AF	Published in release 21B. The following updates are made in this revision: <ul style="list-style-type: none">• Oil name Optimol PD0 is changed to Tribol GR 100-0-PD in <i>Lubrication of spherical roller bearing, balancing device</i> and <i>Replacement of balancing device</i>.• Text regarding fastener quality is updated, see Fastener quality on page 80.
AG	Published in release 22A. The following updates are done in this revision: <ul style="list-style-type: none">• Updated information about Gleitmo treated screws, see Screw joints on page 402.• Removed information about position switches as they are no longer available.
AH	Published in release 22C. The following updates are done in this revision: <ul style="list-style-type: none">• Added information for the OmniCore robot controller, including additional robot variant designations for LID-prepared manipulators.• Added a table note to loads on foundation table.• Removed information for M2000 and M2000A.
AJ	Published in release 22D. The following updates are done in this revision: <ul style="list-style-type: none">• Added a step for overall inspection of cabling after cable harness has been replaced.• Increase space between calibration pin axis 6
AK	Published in release 23B. The following updates are done in this revision: <ul style="list-style-type: none">• Corrected the section Lubrication of spherical roller bearing, balancing device on page 177.• Replaced terms about shipping position to most stable transport position.• Updated the torque value for protection plug.

Product documentation

Categories for user documentation from ABB Robotics

The user documentation from ABB Robotics is divided into a number of categories. This listing is based on the type of information in the documents, regardless of whether the products are standard or optional.



Tip

All documents can be found via myABB Business Portal, www.abb.com/myABB.

Product manuals

Manipulators, controllers, DressPack/SpotPack, and most other hardware is delivered with a **Product manual** that generally contains:

- Safety information.
- Installation and commissioning (descriptions of mechanical installation or electrical connections).
- Maintenance (descriptions of all required preventive maintenance procedures including intervals and expected life time of parts).
- Repair (descriptions of all recommended repair procedures including spare parts).
- Calibration.
- Troubleshooting.
- Decommissioning.
- Reference information (safety standards, unit conversions, screw joints, lists of tools).
- Spare parts list with corresponding figures (or references to separate spare parts lists).
- References to circuit diagrams.

Technical reference manuals

The technical reference manuals describe reference information for robotics products, for example lubrication, the RAPID language, and system parameters.

Application manuals

Specific applications (for example software or hardware options) are described in **Application manuals**. An application manual can describe one or several applications.

An application manual generally contains information about:

- The purpose of the application (what it does and when it is useful).
- What is included (for example cables, I/O boards, RAPID instructions, system parameters, software).
- How to install included or required hardware.
- How to use the application.

Continues on next page

- Examples of how to use the application.

Operating manuals

The operating manuals describe hands-on handling of the products. The manuals are aimed at those having first-hand operational contact with the product, that is production cell operators, programmers, and troubleshooters.

How to read the product manual

Reading the procedures

The procedures contain references to figures, tools, material, and so on. The references are read as described below.

References to figures

The procedures often include references to components or attachment points located on the manipulator/controller. The components or attachment points are marked with *italic text* in the procedures and completed with a reference to the figure where the current component or attachment point is shown.

The denomination in the procedure for the component or attachment point corresponds to the denomination in the referenced figure.

The table below shows an example of a reference to a figure from a step in a procedure.

	Action	Note/Illustration
8.	Remove the <i>rear attachment screws, gearbox</i> .	Shown in the figure Location of gearbox on page xx .

References to required equipment

The procedures often include references to equipment (spare parts, tools, etc.) required for the different actions in the procedure. The equipment is marked with *italic text* in the procedures and completed with a reference to the section where the equipment is listed with further information, that is article number and dimensions.

The designation in the procedure for the component or attachment point corresponds to the designation in the referenced list.

The table below shows an example of a reference to a list of required equipment from a step in a procedure.

	Action	Note/Illustration
3.	Fit a new <i>sealing, axis 2</i> to the gearbox.	Art. no. is specified in Required equipment on page xx .

Safety information

The manual includes a separate safety chapter that must be read through before proceeding with any service or installation procedures. All procedures also include specific safety information when dangerous steps are to be performed.

Read more in the chapter [Safety on page 21](#).

Illustrations

The robot is illustrated with general figures that does not take painting or protection type in consideration.

Likewise, certain work methods or general information that is valid for several robot models, can be illustrated with illustrations that show a different robot model than the one that is described in the current manual.

This page is intentionally left blank

1 Safety

1.1 Safety information

1.1.1 Limitation of liability

Limitation of liability

Any information given in this manual regarding safety must not be construed as a warranty by ABB that the industrial robot will not cause injury or damage even if all safety instructions are complied with.

The information does not cover how to design, install and operate a robot system, nor does it cover all peripheral equipment that can influence the safety of the robot system.

In particular, liability cannot be accepted if injury or damage has been caused for any of the following reasons:

- Use of the robot in other ways than intended.
- Incorrect operation or maintenance.
- Operation of the robot when the safety devices are defective, not in their intended location or in any other way not working.
- When instructions for operation and maintenance are not followed as intended.
- Non-authorized design modifications of the robot.
- Repairs on the robot and its spare parts carried out by in-experienced or non-qualified personnel.
- Foreign objects.
- Force majeure.

Spare parts and equipment

ABB supplies original spare parts and equipment which have been tested and approved for their intended use. The installation and/or use of non-original spare parts and equipment can negatively affect the safety, function, performance, and structural properties of the robot. ABB is not liable for damages caused by the use of non-original spare parts and equipment.

1 Safety

1.1.2 Requirements on personnel

1.1.2 Requirements on personnel

General

Only personnel with appropriate training are allowed to install, maintain, service, repair, and use the robot. This includes electrical, mechanical, hydraulics, pneumatics, and other hazards identified in the risk assessment.

Persons who are under the influence of alcohol, drugs or any other intoxicating substances are not allowed to install, maintain, service, repair, or use the robot.

The plant liable must make sure that the personnel is trained on the robot, and on responding to emergency or abnormal situations.

Personal protective equipment

Use personal protective equipment, as stated in the instructions.

1.2 Safety signals and symbols

1.2.1 Safety signals in the manual







Introduction to safety signals

This section specifies all safety signals used in the user manuals. Each signal consists of:

- A caption specifying the hazard level (DANGER, WARNING, or CAUTION) and the type of hazard.
- Instruction about how to reduce the hazard to an acceptable level.
- A brief description of remaining hazards, if not adequately reduced.

Hazard levels

The table below defines the captions specifying the hazard levels used throughout this manual.

Symbol	Designation	Significance
	DANGER	Signal word used to indicate an imminently hazardous situation which, if not avoided, will result in serious injury.
	WARNING	Signal word used to indicate a potentially hazardous situation which, if not avoided, could result in serious injury.
	ELECTRICAL SHOCK	Signal word used to indicate a potentially hazardous situation related to electrical hazards which, if not avoided, could result in serious injury.
	CAUTION	Signal word used to indicate a potentially hazardous situation which, if not avoided, could result in slight injury.
	ELECTROSTATIC DISCHARGE (ESD)	Signal word used to indicate a potentially hazardous situation which, if not avoided, could result in severe damage to the product.
	NOTE	Signal word used to indicate important facts and conditions.

Continues on next page

1 Safety

1.2.1 Safety signals in the manual

Continued

Symbol	Designation	Significance
	TIP	Signal word used to indicate where to find additional information or how to do an operation in an easier way.

1.2.2 Safety symbols on manipulator labels

Introduction to symbols

This section describes safety symbols used on labels (stickers) on the manipulator. Symbols are used in combinations on the labels, describing each specific warning. The descriptions in this section are generic, the labels can contain additional information such as values.



Note

The symbols on the labels on the product must be observed. Additional symbols added by the integrator must also be observed.



Types of symbols

Both the manipulator and the controller are marked with symbols, containing important information about the product. This is important for all personnel handling the robot, for example during installation, service, or operation.

The safety labels are language independent, they only use graphics. See [Symbols on safety labels on page 25](#).

The information labels can contain information in text.

Symbols on safety labels



Symbol	Description
 xx0900000812	Warning! Warns that an accident <i>may</i> occur if the instructions are not followed that can lead to serious injury, possibly fatal, and/or great damage to the product. It applies to warnings that apply to danger with, for example, contact with high voltage electrical units, explosion or fire risk, risk of poisonous gases, risk of crushing, impact, fall from height, etc.
 xx0900000811	Caution! Warns that an accident may occur if the instructions are not followed that can result in injury and/or damage to the product. It also applies to warnings of risks that include burns, eye injury, skin injury, hearing damage, crushing or slipping, tripping, impact, fall from height, etc. Furthermore, it applies to warnings that include function requirements when fitting and removing equipment where there is a risk of damaging the product or causing a breakdown.
 xx0900000839	Prohibition Used in combinations with other symbols.

Continues on next page



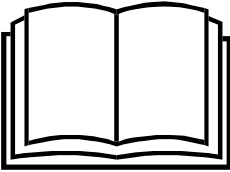
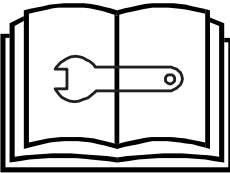
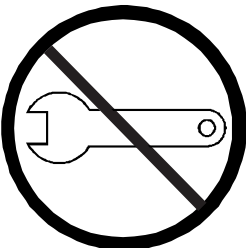
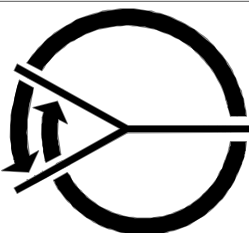

1 Safety

1.2.2 Safety symbols on manipulator labels

Continued

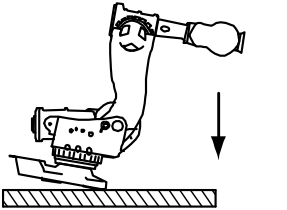
Symbol	Description
 xx0900000813	See user documentation Read user documentation for details. Which manual to read is defined by the symbol: <ul style="list-style-type: none">• No text: <i>Product manual</i>.• EPS: <i>Application manual - Electronic Position Switches</i>.
 xx0900000816	Before disassembly, see product manual
 xx0900000815	Do not disassemble Disassembling this part can cause injury.
 xx0900000814	Extended rotation This axis has extended rotation (working area) compared to standard.
 xx0900000808	Brake release Pressing this button will release the brakes. This means that the robot arm can fall down.

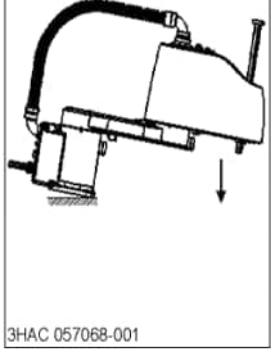

Continues on next page

Symbol	Description
 <p>xx0900000810</p>   <p>3HAC 057068-001</p> <p>xx1500002402</p>	<p>Tip risk when loosening bolts The robot can tip over if the bolts are not securely fastened.</p>
  <p>xx0900000817</p>	<p>Crush Risk of crush injuries.</p>





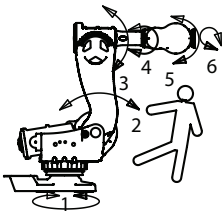
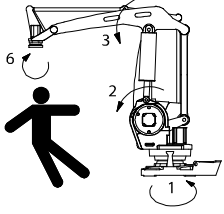
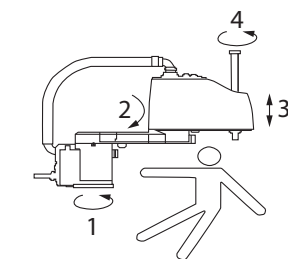

1 Safety

1.2.2 Safety symbols on manipulator labels

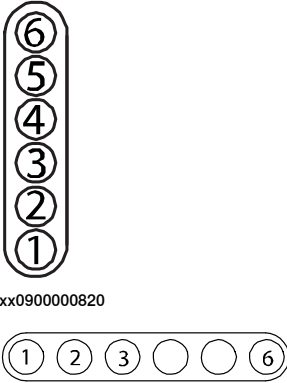
Continued

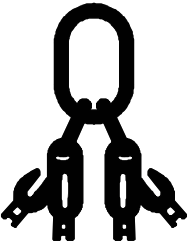
Symbol	Description
 xx0900000818  xx1300001087	Heat Risk of heat that can cause burns. (Both signs are used)
 xx0900000819  xx1000001141  xx1500002616	Moving robot The robot can move unexpectedly.

Continues on next page





Symbol	Description
 <p>xx0900000820</p> <p>xx1000001140</p>	<p>Brake release buttons</p>
 <p>xx0900000821</p>	<p>Lifting bolt</p>
 <p>xx1000001242</p>	<p>Adjustable chain sling with shortener</p>
 <p>xx0900000822</p>	<p>Lifting of robot</p>
 <p>xx0900000823</p>	<p>Oil Can be used in combination with prohibition if oil is not allowed.</p>
 <p>xx0900000824</p>	<p>Mechanical stop</p>

Continues on next page

1 Safety

1.2.2 Safety symbols on manipulator labels

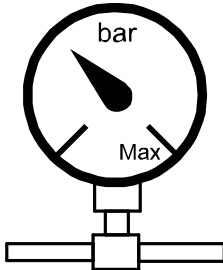
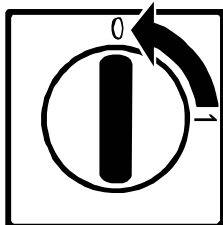
Continued

Symbol	Description
 xx1000001144	No mechanical stop
 xx0900000825	Stored energy Warns that this part contains stored energy. Used in combination with <i>Do not disassemble</i> symbol.
 xx0900000826	Pressure Warns that this part is pressurized. Usually contains additional text with the pressure level.
 xx0900000827	Shut off with handle Use the power switch on the controller.
 xx1400002648	Do not step Warns that stepping on these parts can cause damage to the parts.

1.3 Robot stopping functions

Protective stop and emergency stop

The protective stops and emergency stops are described in the product manual for the controller.

For more information see:

- *Product manual - OmniCore V250XT*
- *Product manual - IRC5*
- *Product manual - IRC5 Panel Mounted Controller*

1 Safety

1.4 Safety during installation and commissioning

1.4 Safety during installation and commissioning

National or regional regulations

The integrator of the robot system is responsible for the safety of the robot system.

The integrator is responsible that the robot system is designed and installed in accordance with the safety requirements set forth in the applicable national and regional standards and regulations.

The integrator of the robot system is required to perform a risk assessment.

Layout

The robot integrated to a robot system shall be designed to allow safe access to all spaces during installation, operation, maintenance, and repair.

If robot movement can be initiated from an external control panel then an emergency stop must also be available.

If the manipulator is delivered with mechanical stops, these can be used for reducing the working space.

A perimeter safeguarding, for example a fence, shall be dimensioned to withstand the following:

- The force of the manipulator.
- The force of the load handled by the robot if dropped or released at maximum speed.
- The maximum possible impact caused by a breaking or malfunctioning rotating tool or other device fitted to the robot.

The maximum TCP speed and the maximum velocity of the robot axes are detailed in the section *Robot motion* in the product specification for the respective manipulator.

Consider exposure to hazards, such as slipping, tripping, and falling.

Hazards due to the working position and posture for a person working with or near the robot shall be considered.

Hazards due to noise emission from the robot needs to be considered.

Consider hazards from other equipment in the robot system, for example, that guards remain active until identified hazards are reduced to an acceptable level.

Allergenic material

See [Environmental information on page 390](#) for specification of allergenic materials in the product, if any.

Securing the robot to the foundation

The robot must be properly fixed to its foundation/support, as described in the respective product manual.

When the robot is installed at a height, hanging, or other than mounted directly on the floor, there will be additional hazards.

Continues on next page

Electrical safety

Incoming mains must be installed to fulfill national regulations.

The power supply wiring to the robot must be sufficiently fused and if necessary, it must be possible to disconnect it manually from the mains power.

The power to the robot must be turned off with the main switch and the mains power disconnected when performing work inside the controller cabinet. Lock and tag shall be considered.

Harnesses between controller and manipulator shall be fixed and protected to avoid tripping and wear.

Wherever possible, power on/off or rebooting the robot controller shall be performed with all persons outside the safeguarded space.



Note

Use a CARBON DIOXIDE (CO₂) extinguisher in the event of a fire in the robot.

Safety devices

The integrator is responsible for that the safety devices necessary to protect people working with the robot system are designed and installed correctly.

When integrating the robot with external devices to a robot system:

- The integrator of the robot system must ensure that emergency stop functions are interlocked in accordance with applicable standards.
- The integrator of the robot system must ensure that safety functions are interlocked in accordance with applicable standards.

Other hazards

A robot may perform unexpected limited movement.



WARNING

Manipulator movements can cause serious injuries on users and may damage equipment.

The risk assessment should also consider other hazards arising from the application, such as, but not limited to:

- Water
- Compressed air
- Hydraulics

End-effector hazards require particular attention for applications which involve close human collaboration with the robot.

Continues on next page

1 Safety

1.4 Safety during installation and commissioning

Continued

Pneumatic or hydraulic related hazards



Note

The pressure in the complete pneumatic or hydraulic systems must be released before service and maintenance.

All components in the robot system that remain pressurized after switching off the power to the robot must be marked with clearly visible drain facilities and a warning sign that indicates the hazard of stored energy.

Loss of pressure in the robot system may cause parts or objects to drop.

Dump valves should be used in case of emergency.

Shot bolts should be used to prevent tools, etc., from falling due to gravity.

All pipes, hoses, and connections have to be inspected regularly for leaks and damage. Damage must be repaired immediately.

Verify the safety functions

Before the robot system is put into operation, verify that the safety functions are working as intended and that any remaining hazards identified in the risk assessment are mitigated to an acceptable level.

1.5 Safety during operation

Automatic operation

Verify the application in the operating mode manual reduced speed, before changing mode to automatic and initiating automatic operation.

Unexpected movement of robot arm



WARNING

Hazards due to the use of brake release devices and/or gravity beneath the manipulator shall be considered.

A robot may perform unexpected limited movement.



WARNING

Manipulator movements can cause serious injuries on users and may damage equipment.

1 Safety

1.6.1 Safety during maintenance and repair

1.6 Safety during maintenance and repair

1.6.1 Safety during maintenance and repair

General

Corrective maintenance must only be carried out by personnel trained on the robot. Maintenance or repair must be done with all electrical, pneumatic, and hydraulic power switched off, that is, no remaining hazards.

Hazards due to stored mechanical energy in the manipulator for the purpose of counterbalancing axes must be considered before maintenance or repair.

Never use the robot as a ladder, which means, do not climb on the controller, manipulator, including motors, or other parts. There are hazards of slipping and falling. The robot might be damaged.

Make sure that there are no loose screws, turnings, or other unexpected parts remaining after work on the robot has been performed.

When the work is completed, verify that the safety functions are working as intended.

Hot surfaces

Surfaces can be hot after running the robot, and touching these may result in burns. Allow the surfaces to cool down before maintenance or repair.

Allergic reaction

Warning	Description	Elimination/Action
 Allergic reaction	When working with lubricants there is a risk of an allergic reaction.	Make sure that protective gear like goggles and gloves are always worn.

Gearbox lubricants (oil or grease)

When handling oil, grease, or other chemical substances the safety information of the respective manufacturer must be observed.









Note

Take special care when handling hot lubricants.

Warning	Description	Elimination/Action
 Hot oil or grease	Changing and draining gearbox oil or grease may require handling hot lubricant heated up to 90 °C.	Make sure that protective gear like goggles and gloves are always worn during this activity.

Continues on next page

Warning	Description	Elimination/Action
 Allergic reaction	When working with lubricants there is a risk of an allergic reaction.	Make sure that protective gear like goggles and gloves are always worn.
 Possible pressure build-up in gearbox	When opening the oil or grease plug, there may be pressure present in the gearbox, causing lubricant to spray from the opening.	Open the plug carefully and keep away from the opening. Do not overfill the gearbox when filling.
 Do not overfill	Overfilling of gearbox lubricant can lead to internal over-pressure inside the gearbox which in turn may: <ul style="list-style-type: none"> • damage seals and gaskets • completely press out seals and gaskets • prevent the robot from moving freely. 	Make sure not to overfill the gearbox when filling it with oil or grease. After filling, verify that the level is correct.
 Do not mix types of oil	Mixing types of oil may cause severe damage to the gearbox.	When filling gearbox oil, do not mix different types of oil unless specified in the instructions. Always use the type of oil specified for the product.
 Oil residues	Oil residues might be present in a drained gearbox and spilled when separating a motor and gearbox during repair.	Make sure that protective gear like goggles/protective visor, gloves and arm protection are always worn during this activity. Put oil absorbent cloth or paper at appropriate locations to catch any oil residues.
 Heat up the oil	Warm oil drains quicker than cold oil.	Run the robot before changing the gearbox oil, if possible.
 Specified amount depends on drained volume	The specified amount of oil or grease is based on the total volume of the gearbox. When changing the lubricant, the amount refilled may differ from the specified amount, depending on how much has previously been drained from the gearbox.	After filling, verify that the level is correct.

Continues on next page

1 Safety

1.6.1 Safety during maintenance and repair

Continued

Warning	Description	Elimination/Action
 Contaminated oil in gearboxes	For lifetime reasons always drain as much oil as possible from the gearbox. The magnetic oil plugs will gather residual metal chips.	

Hazards related to batteries

Under rated conditions, the electrode materials and liquid electrolyte in the batteries are sealed and not exposed to the outside.

There is a hazard in case of abuse (mechanical, thermal, electrical) which leads to the activation of safety valves and/or the rupture of the battery container. As a result under certain circumstances, electrolyte leakage, electrode materials reaction with moisture/water or battery vent/explosion/fire may follow.

Do not short circuit, recharge, puncture, incinerate, crush, immerse, force discharge or expose to temperatures above the declared operating temperature range of the product. Risk of fire or explosion.

Operating temperatures are listed in [Operating conditions, robot on page 47](#).

See safety instructions for the batteries in *Material/product safety data sheet - Battery pack (3HAC043118-001)*.

Unexpected movement of robot arm



WARNING

Hazards due to the use of brake release devices and/or gravity beneath the manipulator shall be considered.

A robot may perform unexpected limited movement.



WARNING

Manipulator movements can cause serious injuries on users and may damage equipment.

Related information

See also the safety information related to installation and operation.

1.6.2 Emergency release of the robot axes

Description

In an emergency situation, the brakes on a robot axis can be released manually by pushing a brake release button.

How to release the brakes is described in the section:

- [Manually releasing the brakes on page 64.](#)

The robot may be moved manually on smaller robot models, but larger models may require using an overhead crane or similar equipment.

Increased injury

Before releasing the brakes, make sure that the weight of the manipulator does not result in additional hazards, for example, even more severe injuries on a trapped person.



DANGER

When releasing the holding brakes, the robot axes may move very quickly and sometimes in unexpected ways.

Make sure no personnel is near or beneath the robot.

1 Safety

1.6.3 Brake testing

1.6.3 Brake testing

When to test

During operation, the holding brake of each axis normally wears down. A test can be performed to determine whether the brake can still perform its function.

How to test

The function of the holding brake of each axis motor may be verified as described below:

- 1 Run each axis to a position where the combined weight of the manipulator and any load is maximized (maximum static load).
- 2 Switch the motor to the MOTORS OFF.
- 3 Inspect and verify that the axis maintains its position.

If the manipulator does not change position as the motors are switched off, then the brake function is adequate.



Note

It is recommended to run the service routine *BrakeCheck* as part of the regular maintenance, see the operating manual for the robot controller.

For robots with the option SafeMove, the *Cyclic Brake Check* routine is recommended. See the manual for SafeMove in [References on page 10](#).

1.7 Safety during troubleshooting

General

When troubleshooting requires work with power switched on, special considerations must be taken:

- Safety circuits might be muted or disconnected.
- Electrical parts must be considered as *live*.
- The manipulator can move unexpectedly at any time.



DANGER

Troubleshooting on the controller while powered on must be performed by personnel trained by ABB or by ABB field engineers.



CAUTION

Risk of hot surfaces that can cause burns.

A risk assessment must be done to address both robot and robot system specific hazards.



WARNING

Hazards due to the use of brake release devices and/or gravity beneath the manipulator shall be considered.

A robot may perform unexpected limited movement.



WARNING

Manipulator movements can cause serious injuries on users and may damage equipment.

Related information

See also the safety information related to installation, operation, maintenance, and repair.

1 Safety

1.8 Safety during decommissioning

1.8 Safety during decommissioning

General

See section [Decommissioning on page 389](#).

If the robot is decommissioned for storage, take extra precaution to reset safety devices to delivery status.

Unexpected movement of robot arm



WARNING

Hazards due to the use of brake release devices and/or gravity beneath the manipulator shall be considered.

A robot may perform unexpected limited movement.



WARNING

Manipulator movements can cause serious injuries on users and may damage equipment.

2 Installation and commissioning

2.1 Introduction to installation and commissioning

General

This chapter contains assembly instructions and information for installing the IRB 6650S at the working site.

See also the product manual for the robot controller.

The installation must be done by qualified installation personnel in accordance with the safety requirements set forth in the applicable national and regional standards and regulations.

The technical data is detailed in section [Technical data on page 45](#).

Safety information

Before any installation work is commenced, all safety information must be observed. There are general safety aspects that must be read through, as well as more specific safety information that describes the danger and safety risks when performing the procedures. Read the chapter [Safety on page 21](#) before performing any installation work.



Note

Always connect the IRB 6650S and the robot to protective earth and residual current device (RCD) before connecting to power and starting any installation work.

For more information see:

- *Product manual - OmniCore V250XT*
- *Product manual - OmniCore V250XT Type A*
- *Product manual - IRC5*
- *Product manual - IRC5 Panel Mounted Controller*

2 Installation and commissioning

2.2.1 Pre-installation procedure

2.2 Unpacking

2.2.1 Pre-installation procedure

Introduction

This section is intended for use when unpacking and installing the robot for the first time. It also contains information useful during later re-installation of the robot.

Prerequisites for installation personnel

Installation personnel working with an ABB product must:

- be trained by ABB and have the required knowledge of mechanical and electrical installation/maintenance/repair work
- conform to all national and local codes.

Checking the pre-requisites for installation

	Action
1	Make a visual inspection of the packaging and make sure that nothing is damaged.
2	Remove the packaging.
3	Check for any visible transport damage.  Note Stop unpacking and contact ABB if transport damages are found.
4	Clean the unit with a lint-free cloth, if necessary.
5	Make sure that the lifting accessory used (if required) is suitable to handle the weight of the robot as specified in: Weight, robot on page 45
6	If the robot is not installed directly, it must be stored as described in: Storage conditions, robot on page 47
7	Make sure that the expected operating environment of the robot conforms to the specifications as described in: Operating conditions, robot on page 47
8	Before taking the robot to its installation site, make sure that the site conforms to: <ul style="list-style-type: none">• Loads on foundation, robot on page 46• Protection classes, robot on page 48• Requirements, foundation on page 47
9	Before moving the robot, please observe the stability of the robot: Risk of tipping/stability on page 53
10	When these prerequisites are met, the robot can be taken to its installation site as described in section: On-site installation on page 55
11	Install required equipment, if any. <ul style="list-style-type: none">• Safety lamp (option for IRC5) on page 81• Installation of base spacers (option) on page 82

2.2.2 Technical data

Weight, robot

The table shows the weight of the robot.

The weight does not include the weight of the DressPack.

Robot model	Weight
IRB 6650S	2275 kg



Note

The weight does not include tools and other equipment fitted on the robot.
The weight does not include the weight of the DressPack.

Mounting positions

The table shows valid mounting options for the manipulator.

Mounting option	Installation angle	Note
Floor mounted	0° ⁱ	

ⁱ A tilt of up to 5° does not affect the payload or reach, but it can have a negative impact on performance and lifetime. The actual value must be set in the system parameters.



Note

The actual mounting angle must always be configured in the system parameters, otherwise the performance and lifetime is affected.

Continues on next page

2 Installation and commissioning

2.2.2 Technical data

Continued

Loads on foundation, robot

The illustration shows the directions of the robots stress forces.

The directions are valid for all floor mounted, suspended and inverted robots.

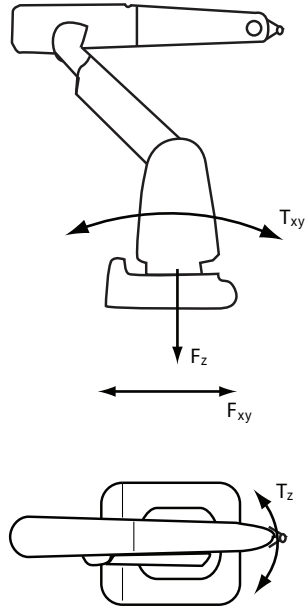

xx1100000521

F_{xy}	Force in any direction in the XY plane
F_z	Force in the Z plane
T_{xy}	Bending torque in any direction in the XY plane
T_z	Bending torque in the Z plane

The table shows the various forces and torques working on the robot during different kinds of operation.



Note

These forces and torques are extreme values that are rarely encountered during operation. The values also never reach their maximum at the same time!



WARNING

The robot installation is restricted to the mounting options given in following load table(s).

Floor mounted

Force	Endurance load (in operation)	Max. load (emergency stop)
Force xy	± 10.6 kN	± 20.9 kN
Force z	28.2 ± 7.7 kN	28.2 ± 16.4 kN
Torque xy	± 28.2 kNm ± 31 kNm ⁱ	± 50.5 kNm ± 55.6 kNm ^f

Continues on next page

Force	Endurance load (in operation)	Max. load (emergency stop)
Torque z	± 7.9 kNm	± 13.6 kNm

ⁱ When using base spacers (option).

Requirements, foundation

The table shows the requirements for the foundation where the weight of the installed robot is included:

Requirement	Value	Note
Flatness of foundation surface	0.3 mm	Flat foundations give better repeatability of the resolver calibration compared to original settings on delivery from ABB. The value for levelness aims at the circumstance of the anchoring points in the robot base. In order to compensate for an uneven surface, the robot can be recalibrated during installation. If resolver/encoder calibration is changed this will influence the absolute accuracy.
Minimum resonance frequency	22 Hz  Note It may affect the manipulator life-time to have a lower resonance frequency than recommended.	The value is recommended for optimal performance. Due to foundation stiffness, consider robot mass including equipment. ⁱ For information about compensating for foundation flexibility, see the application manual of the controller software, section <i>Motion Process Mode</i> .

ⁱ The minimum resonance frequency given should be interpreted as the frequency of the robot mass/inertia, robot assumed stiff, when a foundation translational/torsional elasticity is added, i.e., the stiffness of the pedestal where the robot is mounted. The minimum resonance frequency should not be interpreted as the resonance frequency of the building, floor etc. For example, if the equivalent mass of the floor is very high, it will not affect robot movement, even if the frequency is well below the stated frequency. The robot should be mounted as rigid as possible to the floor.

Disturbances from other machinery will affect the robot and the tool accuracy. The robot has resonance frequencies in the region 10 – 20 Hz and disturbances in this region will be amplified, although somewhat damped by the servo control. This might be a problem, depending on the requirements from the applications. If this is a problem, the robot needs to be isolated from the environment.

Storage conditions, robot

The table shows the allowed storage conditions for the robot:

Parameter	Value
Minimum ambient temperature	-25° C
Maximum ambient temperature	+55° C
Maximum ambient temperature (less than 24 hrs)	+70° C
Maximum ambient humidity	95% at constant temperature (gaseous only)

Operating conditions, robot

The table shows the allowed operating conditions for the robot:

Parameter	Value
Minimum ambient temperature	+5°

Continues on next page

2 Installation and commissioning

2.2.2 Technical data

Continued

Parameter	Value
Maximum ambient temperature	+50°
Maximum ambient humidity	Max. 95% at constant temperature.

Protection classes, robot

The table shows the available protection types of the robot, with the corresponding protection class.

Protection type	Protection class ⁱ
Manipulator, protection type Standard	IP 67
Manipulator, protection type Foundry Plus	IP 67

ⁱ According to IEC 60529.

2.2.3 Working range and type of motion

Working range

The following figures show the working ranges of the robot variants. The extreme positions of the robot arm are specified at the wrist center (dimensions in mm).

IRB 6650S - 200/3.0

The illustration below shows the unrestricted working range of IRB 6650S - 200/3.0:

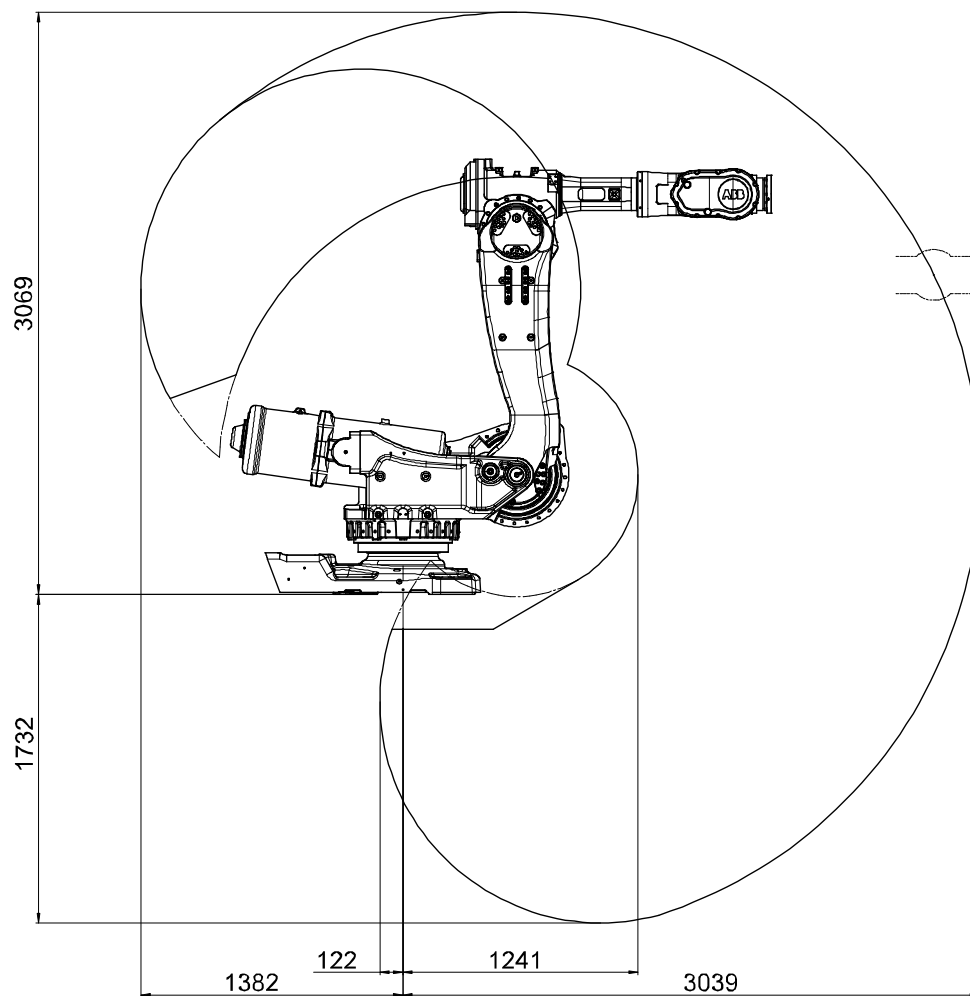

Continues on next page

2 Installation and commissioning

2.2.3 Working range and type of motion

Continued

IRB 6650S - 125/3.5

The illustration below shows the unrestricted working range of IRB 6650S - 125/3.5:

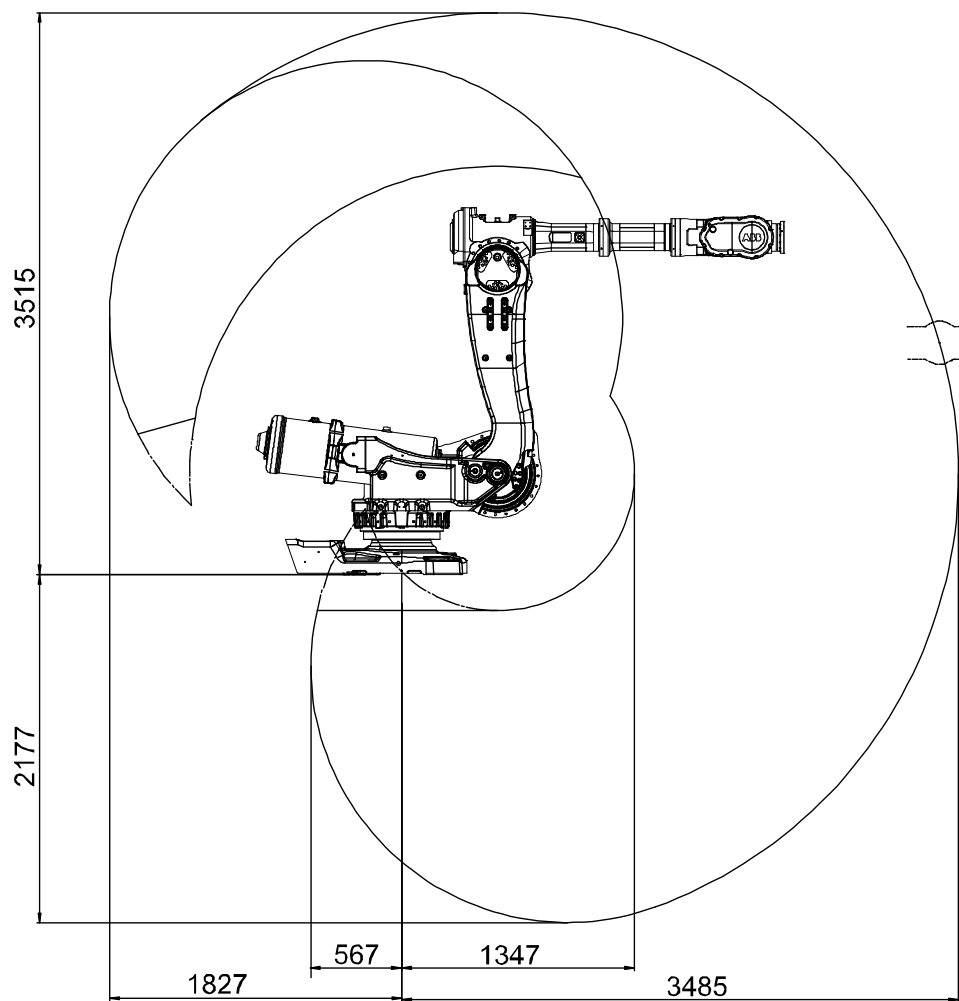

xx0300000563

Continues on next page

2 Installation and commissioning

2.2.3 Working range and type of motion

Continued

IRB 6650S - 90/3.9

The illustration below shows the unrestricted working range of IRB 6650S - 90/3.9:

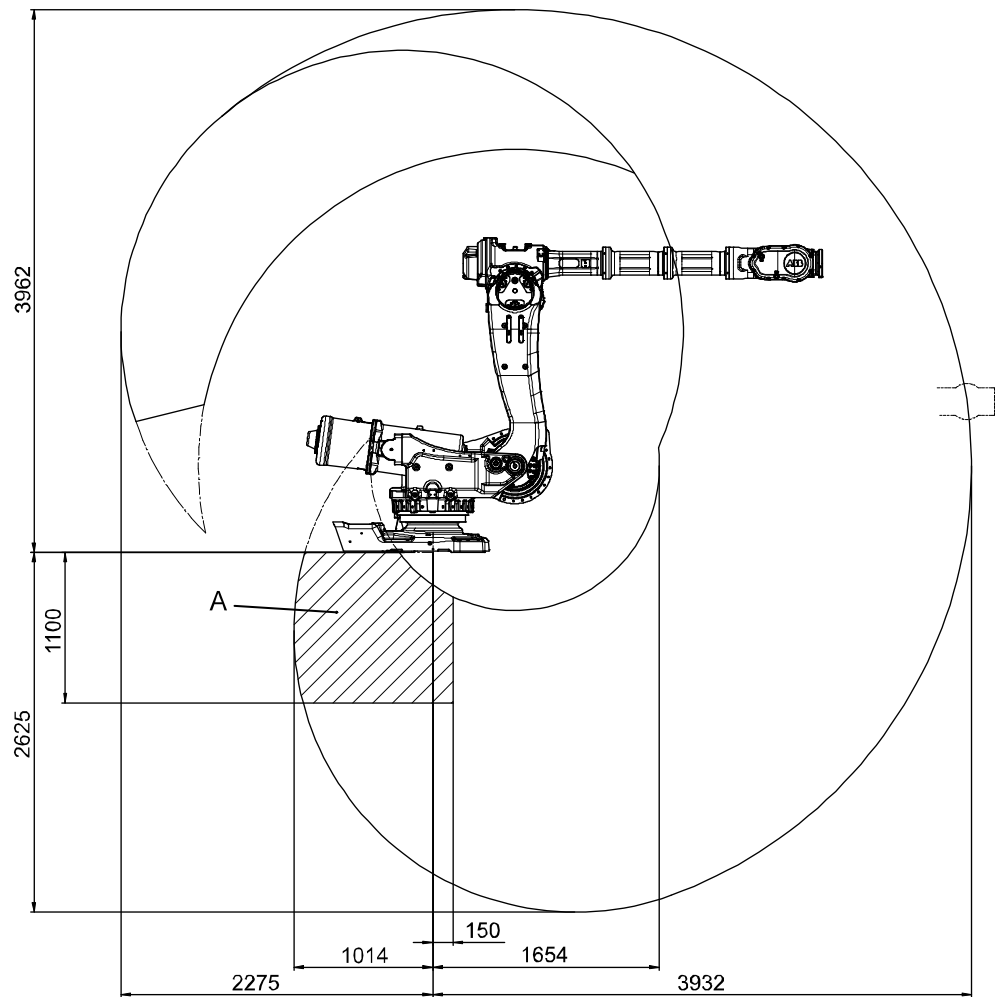

xx0600002739

A	Marked area: max. payload 50 kg
---	---------------------------------

Continues on next page

2 Installation and commissioning

2.2.3 Working range and type of motion

Continued

Turning radius

The turning radius, shown as A in the figure below, is specified for the different robot variants below the figure.

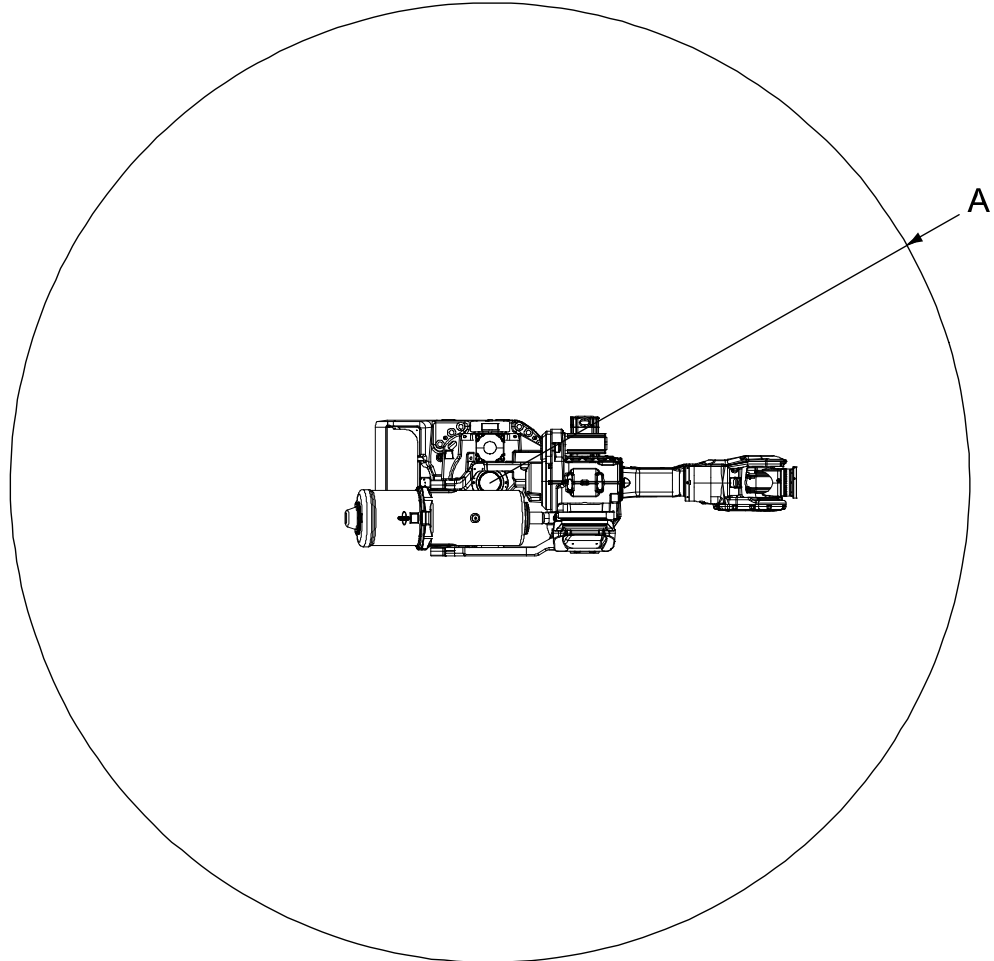

xx0600002740

IRB 6650S - 200/3.0	3039 mm
IRB 6650S - 125/3.5	3485 mm
IRB 6650S - 90/3.9	3932 mm

Type of motion

Axis	Type of motion	Range of movement	Note
1	Rotation motion	+180° to -180°	+220° to -220° (option Extended working range)
2	Arm motion	+160° to -40°	
3	Arm motion	+70° to -180°	
4	Wrist motion	+300° to -300°	
5	Bend motion	+120° to -120°	
6	Turn motion	+300° to -300°	

2.2.4 Risk of tipping/stability

Risk of tipping

If the robot is not fastened to the foundation while moving the arm, the robot is not stable in the whole working area. Moving the arm will displace the center of gravity, which may cause the robot to tip over.

The transportation position is the most stable position.

Do not change the robot position before securing it to the foundation!

Transportation position

This figure shows the robot in its transportation position.

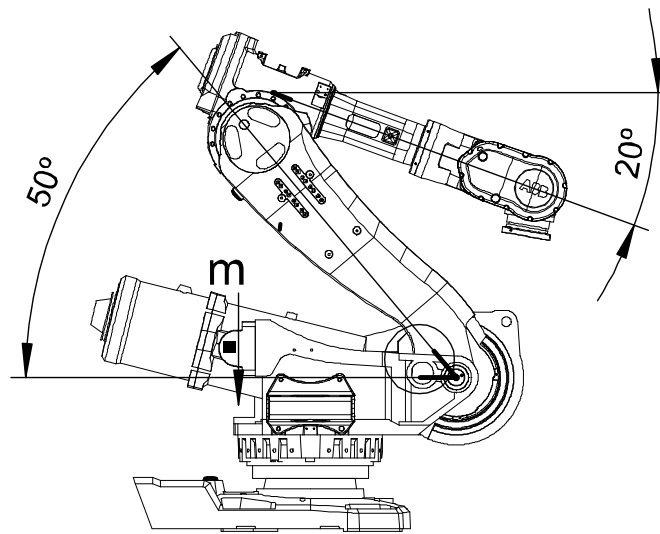

xx0300000632



Note

The robot might be positioned in a different position at delivery, due to actual configurations and options (for example DressPack).



WARNING

The robot will be mechanically unstable if not properly secured to the foundation.

2 Installation and commissioning

2.2.5 The unit is sensitive to ESD

2.2.5 The unit is sensitive to ESD

Description

ESD (electrostatic discharge) is the transfer of electrical static charge between two bodies at different potentials, either through direct contact or through an induced electrical field. When handling parts or their containers, personnel not grounded may potentially transfer high static charges. This discharge may destroy sensitive electronics.

Safe handling

Use one of the following alternatives:

- Use a wrist strap.

Wrist straps must be tested frequently to ensure that they are not damaged and are operating correctly.

- Use an ESD protective floor mat.

The mat must be grounded through a current-limiting resistor.

- Use a dissipative table mat.

The mat should provide a controlled discharge of static voltages and must be grounded.

2.3 On-site installation

2.3.1 Lifting robot with fork lift

General

The robot may be moved using a fork lift, provided that available special aids are used.

This section describes how to attach the fork lift equipment to the robot.

Attachment points on robot

The attachment points for the fork lift equipment are shown in this figure.

Notice the length of the IRB 6650S balancing device when planning to lift with a fork lift, shown in the figure below.

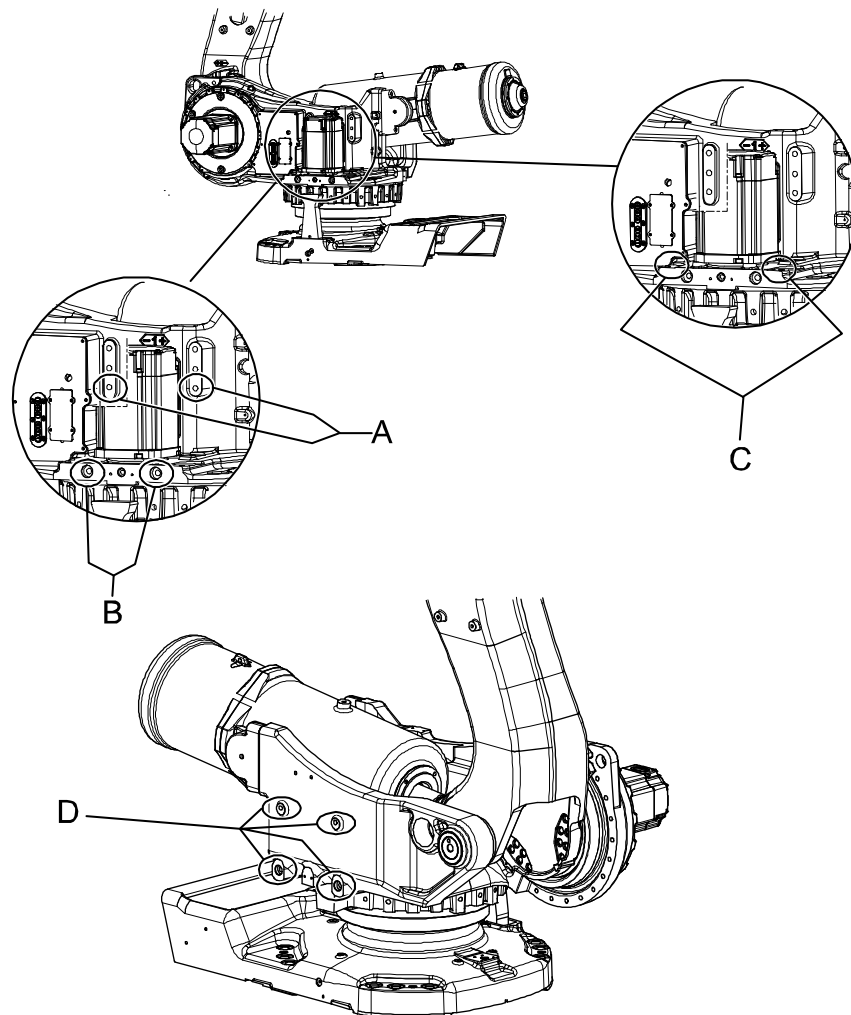

xx0300000463

A	Attachment points, spacer and horizontal attachment screws
B	Attachment points, horizontal attachment screws
C	Attachment points, vertical attachment screws

Continues on next page

2 Installation and commissioning

2.3.1 Lifting robot with fork lift

Continued

D	Attachment points, horizontal attachment screws
---	---

Required equipment

Equipment, etc.	Art. no.	Note
Fork lift accessory, incl. all required hardware	3HAC0604-2	
Standard toolkit	-	Content is defined in section Standard tools on page 406 .

Fork lift accessory, 3HAC0604-2

The Fork lift accessory, 3HAC0604-2, is fitted to the robot as shown in the figure below.

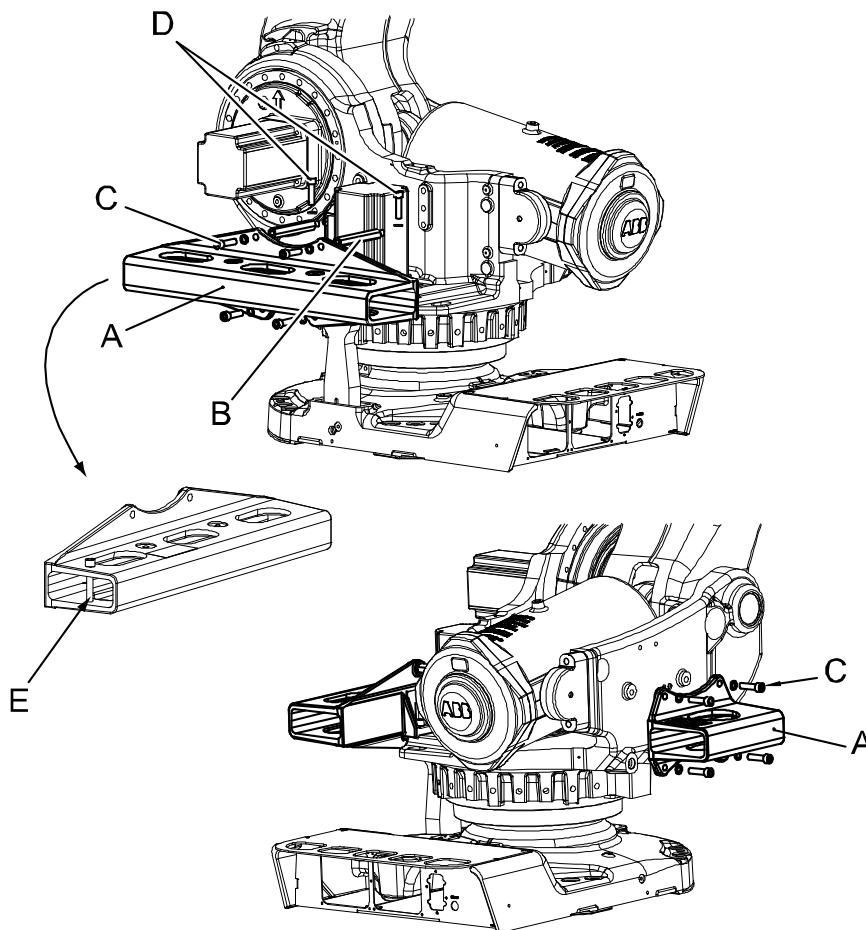



xx0200000379

A	Fork lift pocket (2 pcs, 3HAC15766-1 , 3HAC11264-1)
B	Spacer (2 pcs)
C	Horizontal attachment screws (4 pcs/ fork lift pocket)
D	Vertical attachment screws (2 pcs)

Continues on next page

Lifting robot with fork lift

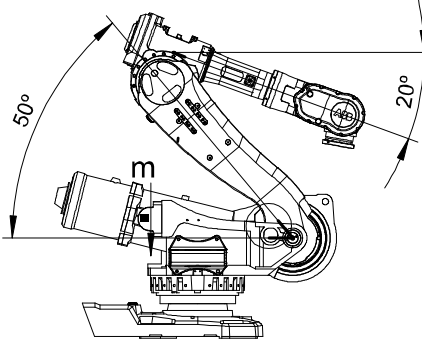
This section details how to secure the fork lift set to the robot in order to lift and move the robot using the fork lift **ONLY!**

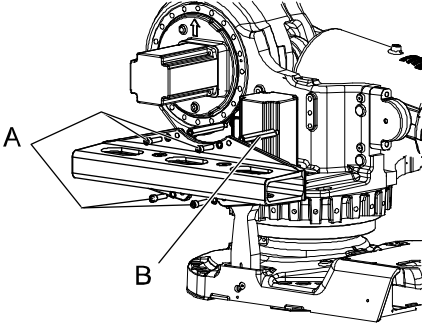



	Action	Note
1	If a cooling fan for the axis 1 motor is used, it must be removed in order to use the fork lift device!	
2	Position the robot as shown in the figure to the right!	<p>Release the brakes if required as detailed in section Manually releasing the brakes on page 64.</p>  <p>xx0300000632</p>
3	Fit the two <i>spacers</i> to the robot and secure.	Attachment points are shown in figure Attachment points on robot on page 55 .
4	 CAUTION The fork lift pocket weighs 60 kg!	
5	<p>Secure the longer <i>fork lift pocket</i> to the spacers with four of the <i>horizontal attachment screws</i> and washers.</p>  Note The screws, which are attached horizontally and vertically, are identical. However, they are tightened with different torque!	<p>Always use original screws (or replacements of equivalent quality: M16, quality 12.9)!</p> <p>Attachment points on the robot are shown in figure Attachment points on robot on page 55.</p>  <p>xx0400001068</p> <p>A Horizontal attachment screws, 4 pcs, M16 x 60. Tightening torque: 60 Nm. B Spacers, 2 pcs.</p>

Continues on next page

2 Installation and commissioning

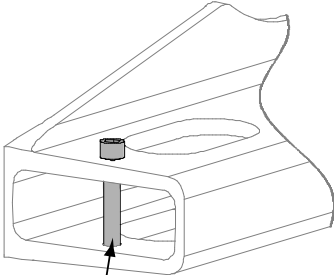
2.3.1 Lifting robot with fork lift

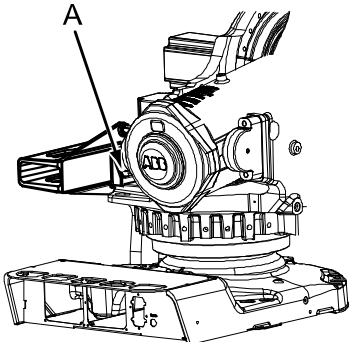
Continued



	Action	Note
6	<p>Make sure the securing screw is fitted to the longer fork lift pocket.</p> <p>It prevents the fork of the fork lift to be inserted too far into the pocket and thereby damaging the motor of axis 2.</p>	 <p>A</p> <p>xx0400000977</p> <p>A Securing screw</p>
7	<p>Secure fork lift pocket to robot with two <i>vertical attachment screws</i> and washers.</p> <p> Note</p> <p>Vertically and the horizontally attached screws are identical, but tightened with different torques!</p>	 <p>A</p> <p>xx0300000464</p> <p>A Vertical attachment screws, 2 pcs, M16x60. Tightening torque: 270 Nm.</p> <p>Always use original screws (or replacements of equivalent quality: M16, quality 12.9)!</p> <p>Attachment points on robot are shown in figure Attachment points on robot on page 55.</p>
8	<p> CAUTION</p> <p>The fork lift pocket weighs 22 kg!</p>	
9	<p>Secure the shorter fork lift pocket on the other side of the robot with the four remaining <i>horizontal attachment screws</i>.</p>	<p>4 pcs, M16x60.</p> <p>Tightening torque: 60 Nm.</p> <p>Always use original screws (or replacements of equivalent quality: M16, quality 12.9)!</p> <p>Attachment points on robot are shown in figure Attachment points on robot on page 55.</p>

Continues on next page

2 Installation and commissioning

2.3.1 Lifting robot with fork lift

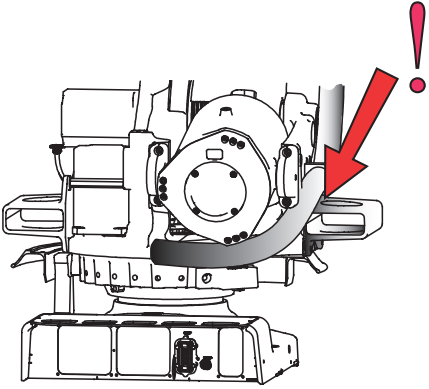
Continued

	Action	Note
10	Double-check that pockets are properly secured to the robot! Insert fork lift forks into the pockets.	 <p>xx0200000380</p> <p>Reposition harness, if any, before using a fork lift!</p>
11	 CAUTION The IRB 6650S robot weighs 2275 kg. All lifting accessories used must be sized accordingly!	
12	Carefully lift the robot and move it to its installation site.	
13	 WARNING Personnel must not, under any circumstances, be present under the suspended load!	
14	Refit the cooling fan to the motor, if any.	

2 Installation and commissioning

2.3.2 Lifting robot with roundslings

2.3.2 Lifting robot with roundslings



General

The robot can be lifted with roundslings according to this section.

Sling specification

Sling type	Qty	Lifting capacity	Length / Note
Chain sling with shortener	4 pcs	4 000 kg	0.43 m 0.605 m 0.75 m 0.785 m
Roundslings, robot	4 pcs	2 000 kg	2 m

Lifting with roundslings

	Action	Note
1	Position robot in a secure transport position.	
2	Attach roundslings to robot according to figure Attachment points on page 61 .	
3	 CAUTION The IRB 6650S robot weighs 2275 kg. All lifting accessories used must be sized accordingly!	
4	 WARNING Personnel must not, under any circumstances, be present under the suspended load!	

Continues on next page

Attachment points

This figure shows how to attach the roundslings to the robot.

The illustration is similar with the label attached to the robot's lower arm.

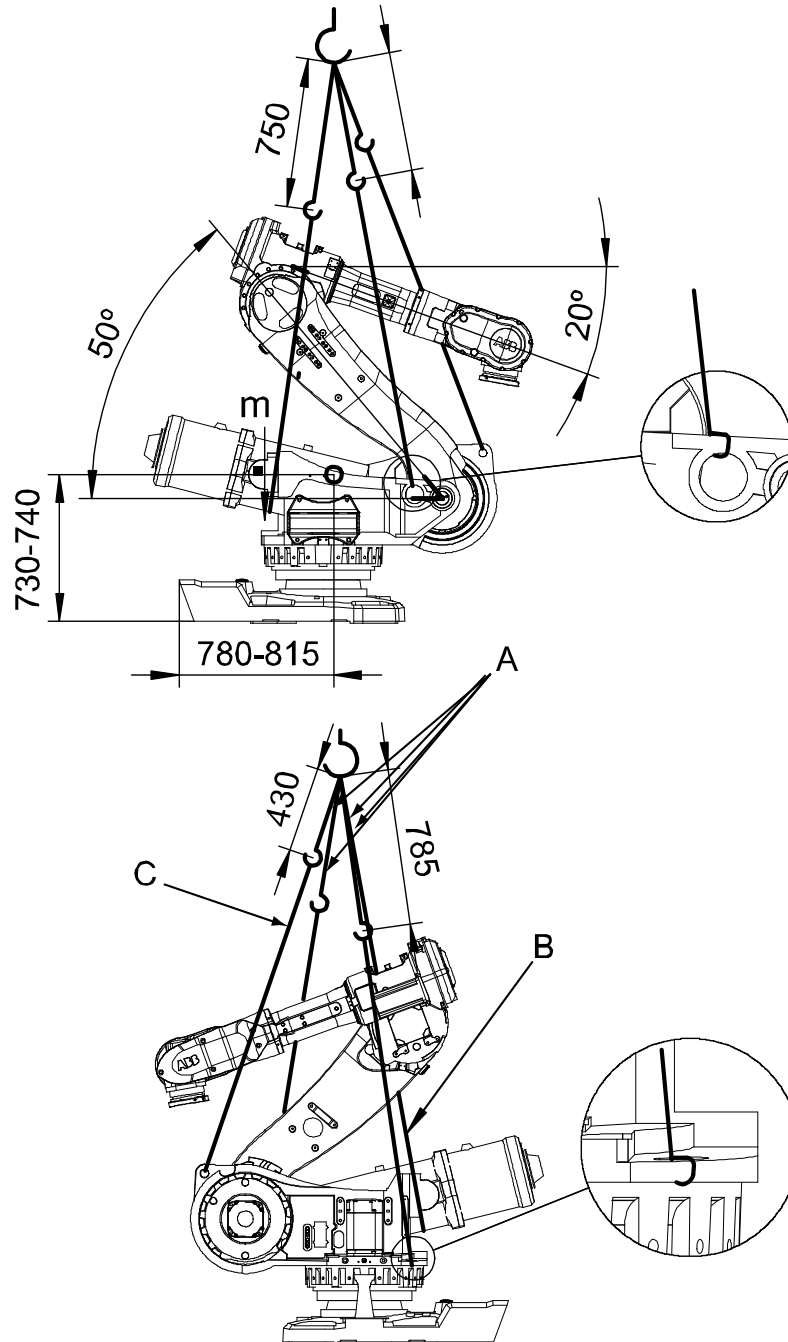

xx040000679

A	Chain sling with shortener
B	Roundslings, robot
C	Roundslings, used to secure against rotation

2 Installation and commissioning

2.3.3 Lifting robot with lifting accessory (recommended lifting method)

2.3.3 Lifting robot with lifting accessory (recommended lifting method)

General

This section contains a general overview of how to lift the complete robot using special lifting accessory.

Illustration, lifting accessory

The following figure shows the principle for how to use and lift the entire robot with lifting accessory. For a more detailed instruction, see the user instructions enclosed with the accessory.



Note

The user manual may be out of date. The latest revision is available for download via myABB Business Portal, www.abb.com/myABB.

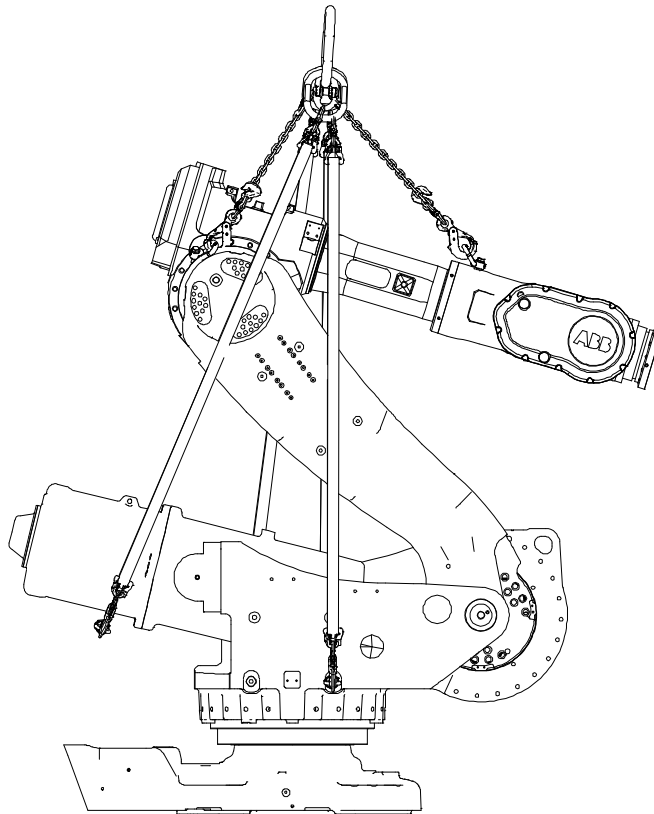

xx040000722

Required equipment

Equipment	Article number	Note
Lifting accessory, robot	3HAC15607-1	Includes user instructions 3HAC15971-2

Continues on next page



Slings attached directly onto robot

This section details how to lift and move the robot using lifting slings when these are attached directly onto the robot.



Note

Please refer to the enclosed user instruction for instruction how to place the manipulator in an correct position. Attempting to lift a manipulator in any other position may result in the robot tipping over, causing severe damage or injury!

	Action	Note
1	Run the overhead crane to a position above the robot.	
2	Position the robot as detailed in enclosed instruction!	Article number is specified in Required equipment on page 62 . Release the brakes, if required, as detailed in section Manually releasing the brakes on page 64 .
3	Fit the <i>lifting accessory</i> to the robot as described in the enclosed instruction! Go to the user instructions enclosed with the lifting accessory.  DANGER Handling the tool incorrectly will cause serious injury. Read and follow enclosed user instructions for the tool.	Article number is specified in Required equipment on page 62 .
4	 CAUTION The IRB 6650S robot weighs 2275 kg. All lifting accessories used must be sized accordingly!	
5	 WARNING Personnel must not, under any circumstances, be present under the suspended load!	
6	Raise overhead crane to lift the robot.	Make sure all hooks and attachments maintain their correct positions while lifting the robot! Always move the robot at very low speeds, making sure it does not tip.

2 Installation and commissioning

2.3.4 Manually releasing the brakes

2.3.4 Manually releasing the brakes

Introduction to manually releasing the brakes

This section describes how to release the holding brakes for the motors of each axis.

Location of brake release unit

The internal brake release unit is located as shown in the figure.

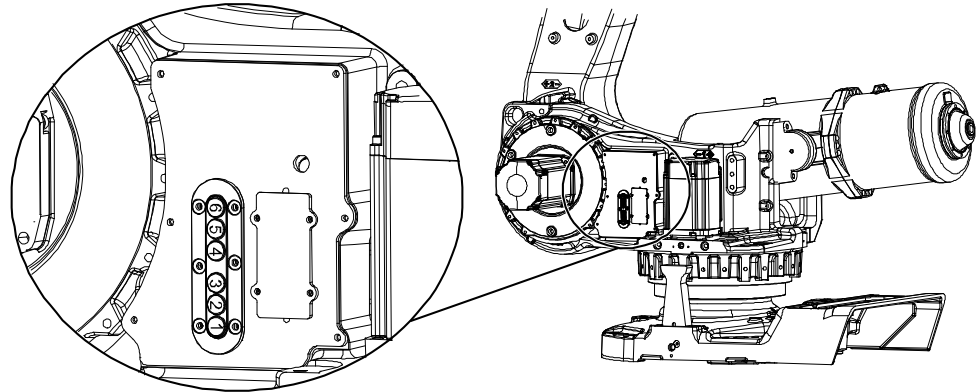

xx0300000564

Releasing the brakes

This procedure details how to release the holding brakes when the robot is equipped with an internal brake release unit.

	Action	Note
1	<p>The internal brake release unit is equipped with buttons for controlling the axes brakes. The buttons are numbered according to the numbers of the axes.</p> <p>If the robot is not connected to the controller, power must be supplied to the connector R1.MP according to the section Supplying power to connector R1.MP on page 65.</p>	<p>Buttons are shown in figure Location of brake release unit on page 64.</p>
2	<p> DANGER</p> <p>When releasing the holding brakes, the robot axes may move very quickly and sometimes in unexpected ways.</p> <p>Make sure no personnel is near or beneath the robot.</p>	
3	<p>Release the holding brake on a particular robot axis by pressing the corresponding button on the internal brake release unit.</p> <p>The brake will function again as soon as the button is released.</p>	

Continues on next page

Supplying power to connector R1.MP

If the robot is not connected to the controller, power must be supplied to connector R1.MP on the robot, in order to enable the brake release buttons.

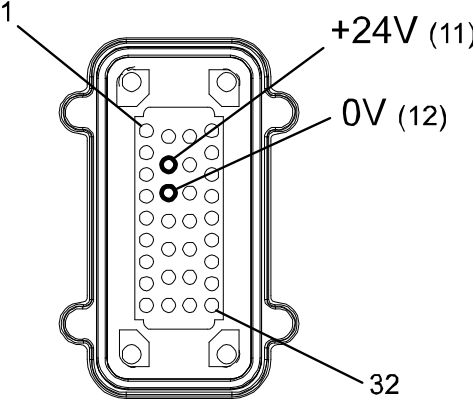
	Action	Note
1	 <p>DANGER</p> <p>Incorrect connections, such as supplying power to the wrong pin, may cause all brakes to be released simultaneously!</p>	
2	Supply 0V on pin 12 and 24V on pin 11.	 <p>xx0600002937</p>

2 Installation and commissioning

2.3.5 Lifting the base plate

2.3.5 Lifting the base plate

Required equipment

Equipment	Article number	Note
Lifting eye, M16	3HAC14457-4	3 pcs
Lifting slings		Length: approx. 2 m

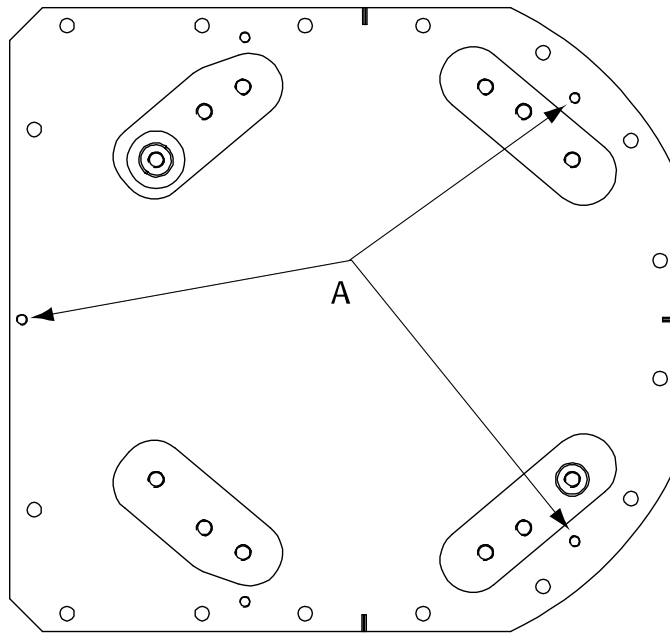

Hole configuration



xx0200000096

A	Attachment holes for lifting eyes (x3)
---	--

Lifting, base plate

	Action	Note
1	 CAUTION The base plate weighs 353 kg. All lifting accessories used must be sized accordingly.	
2	Fit lifting eyes in specified holes.	Shown in figure Hole configuration on page 66 .
3	Fit lifting slings to the eyes and to the lifting accessory.  CAUTION Lift and move the base plate very slowly. If the base plate starts to swing it is a risk for injuries or damage.	

2.3.6 Securing the base plate

Base plate, dimensions

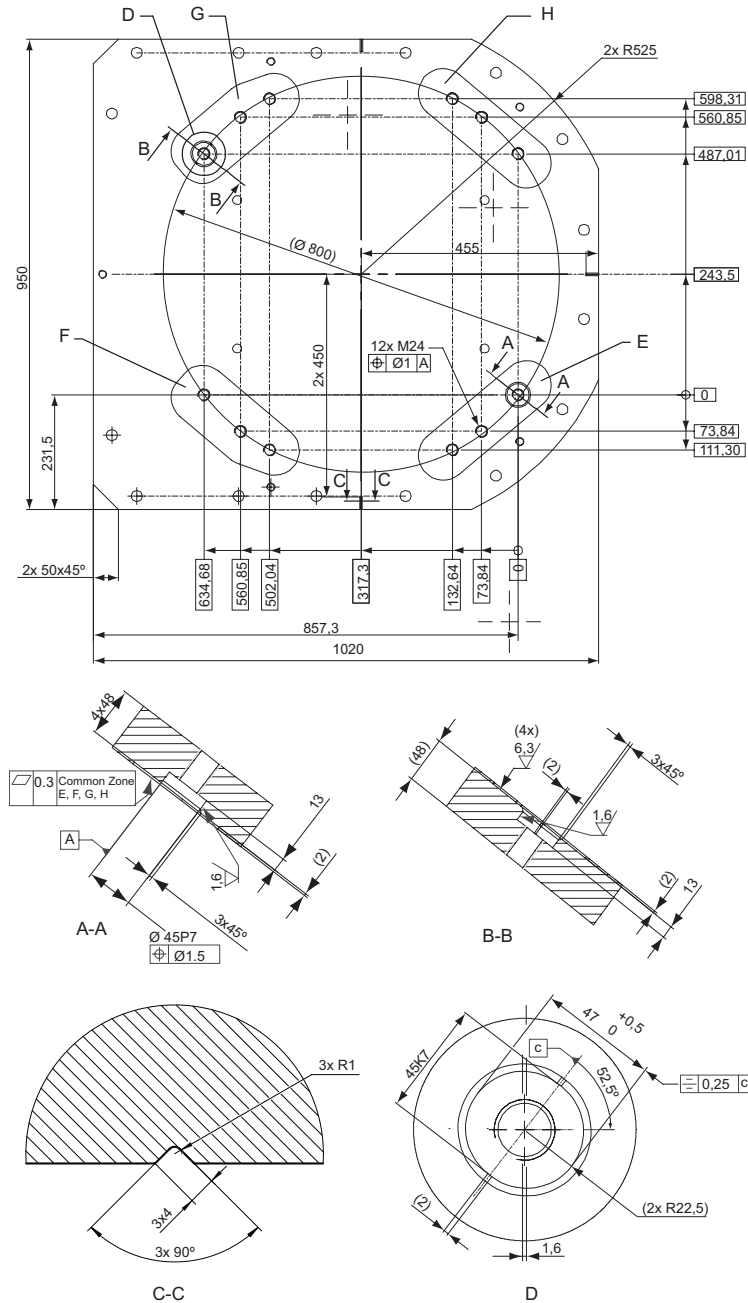

xx1000001053

E, F, G, H Common tolerance zone (accuracy all over the base plate from one contact surface to the other)

Continues on next page

2 Installation and commissioning

2.3.6 Securing the base plate

Continued

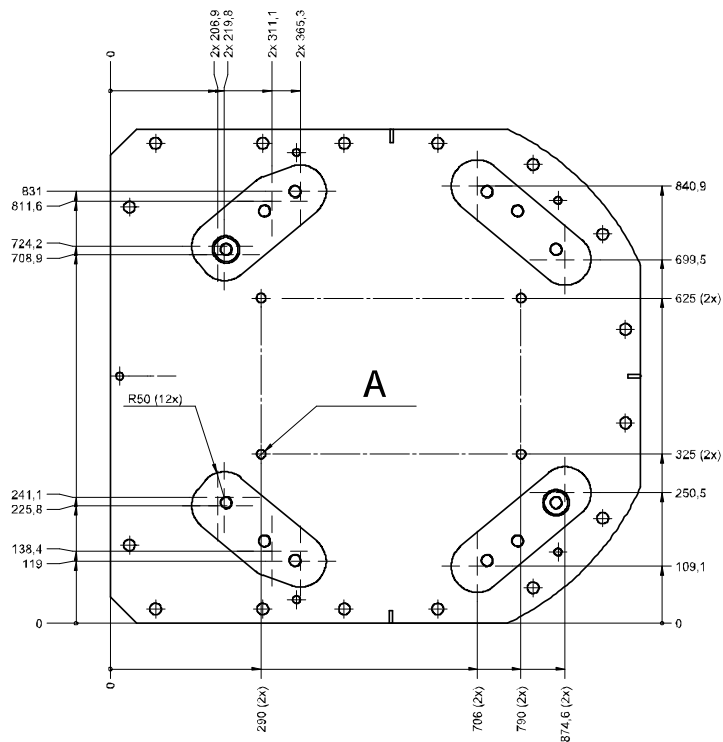
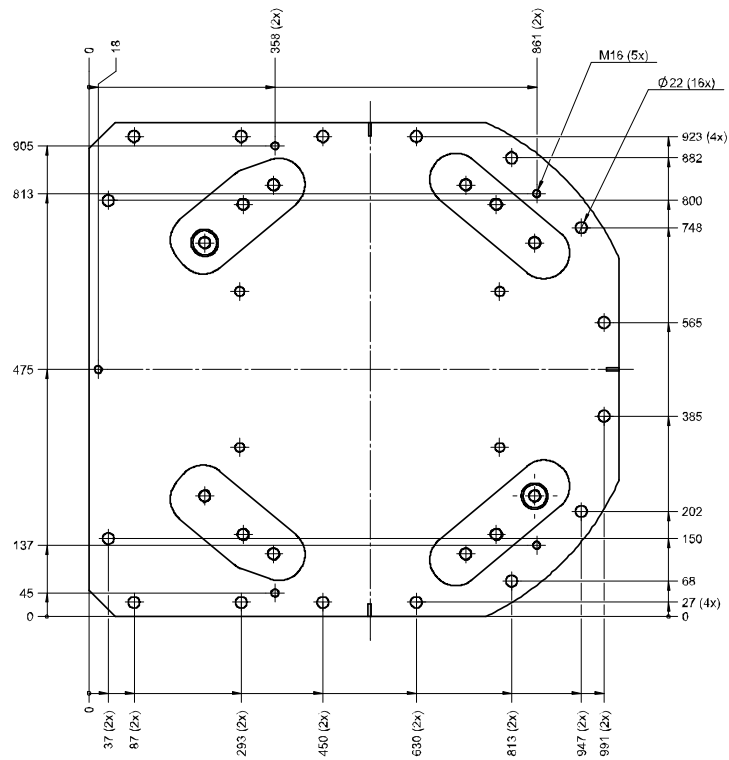

xx0400000715

A	Four holes for alternative clamping, 4x Ø18
---	---

Continues on next page

Base plate, orienting grooves and leveling bolts

The illustration below shows the orienting grooves and attachment holes for leveling bolts in the base plate.

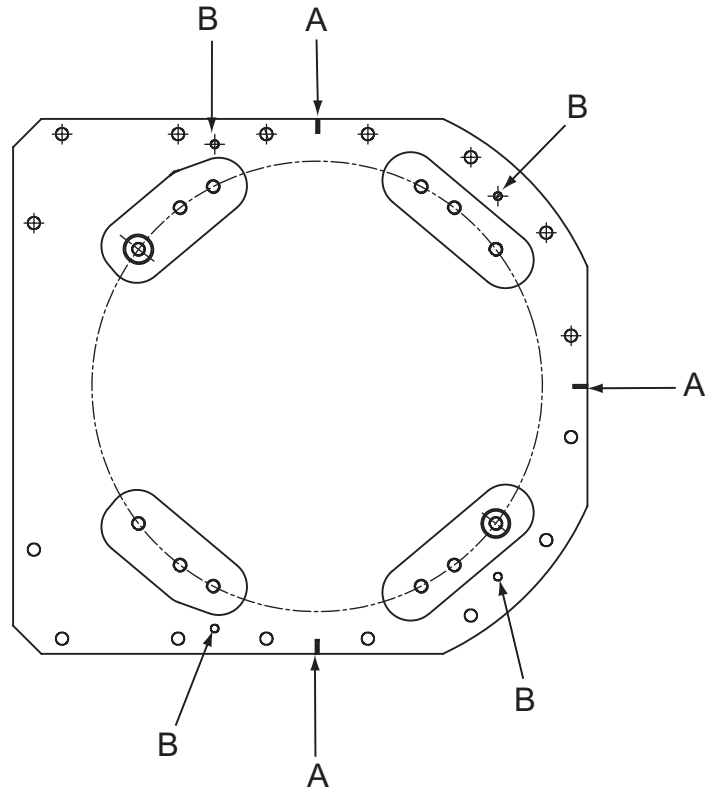

xx1500000312

A	Orienting grooves (3 pcs)
B	Levelling bolts, attachment holes (4 pcs)

Continues on next page

2 Installation and commissioning

2.3.6 Securing the base plate

Continued

Base plate, guide sleeve holes

The illustration below shows the orienting grooves and guide sleeve holes in the base plate.

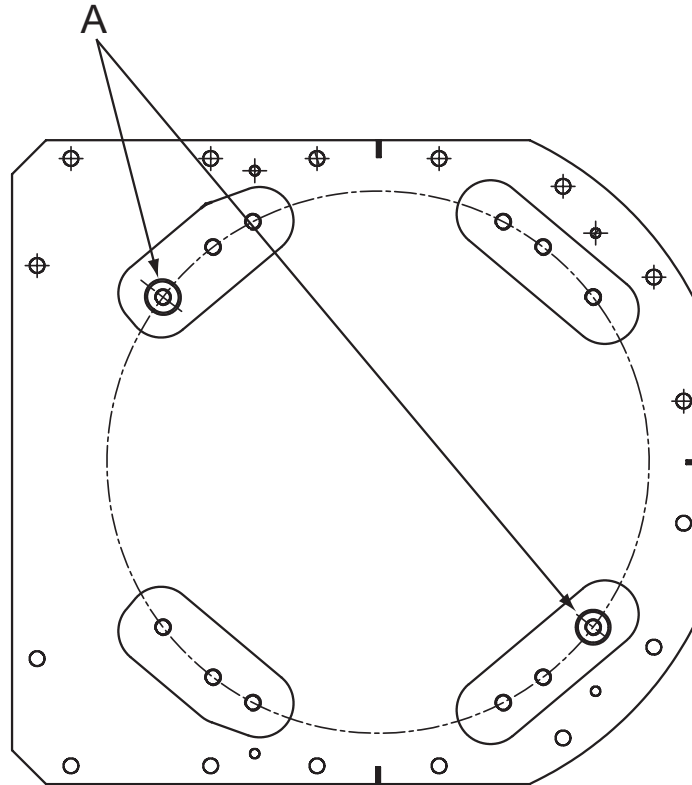

xx030000045

A	Guide sleeve holes (2 pcs)
---	----------------------------

Required equipment

Equipment	Article number	Note
Base plate	3HAC12937-8	Includes <ul style="list-style-type: none"> • guide sleeves, 3HAC12937-3 • levelling screws, 9ADA120-79 • attachment screws and washers for securing the robot to the base plate.
Standard toolkit	-	Content is defined in section Standard tools on page 406 .
Other tools and procedures may be required. See references to these procedures in the step-by-step instructions below.		These procedures include references to the tools required.

Base plate

This section details how to secure the base plate to the foundation.

	Action	Note
1	Make sure the foundation is levelled.	

Continues on next page

	Action	Note
2	 CAUTION The base plate weighs 353 kg! All lifting equipment used must be sized accordingly!	
3	Position base plate in relation to the robot work location using the grooves in the base plate.	Shown in figure Base plate, orienting grooves and leveling bolts on page 69 .
4	Lift the base plate to its mounting position.	Detailed in section Lifting the base plate on page 66 .
5	Use the base plate as a template and drill attachment holes as required by the selected bolt dimension.	Attachment holes: 16 pcs.
6	Fit the base plate and use the levelling bolts to level the base plate.	Shown in figure Base plate, orienting grooves and leveling bolts on page 69 .
7	If required, fit strips of sheet metal underneath the base plate to fill any gaps.	
8	Secure the base plate to the foundation with screws and sleeves.	
9	Recheck the four contact surfaces on the base plate to make sure the base plate is levelled and flat. If it is not, use pieces of sheet metal or similar to bring the base plate to a levelled position.	Maximum allowed deviation all over the base plate, from one contact surface to the other: 0.3 mm.

2 Installation and commissioning

2.3.7 Orienting and securing the robot

2.3.7 Orienting and securing the robot

General

This section details how to orient and secure the robot to the base plate in order to run the robot safely.

Illustration, robot fitted to base plate

This illustration shows the robot base fitted to the base plate.

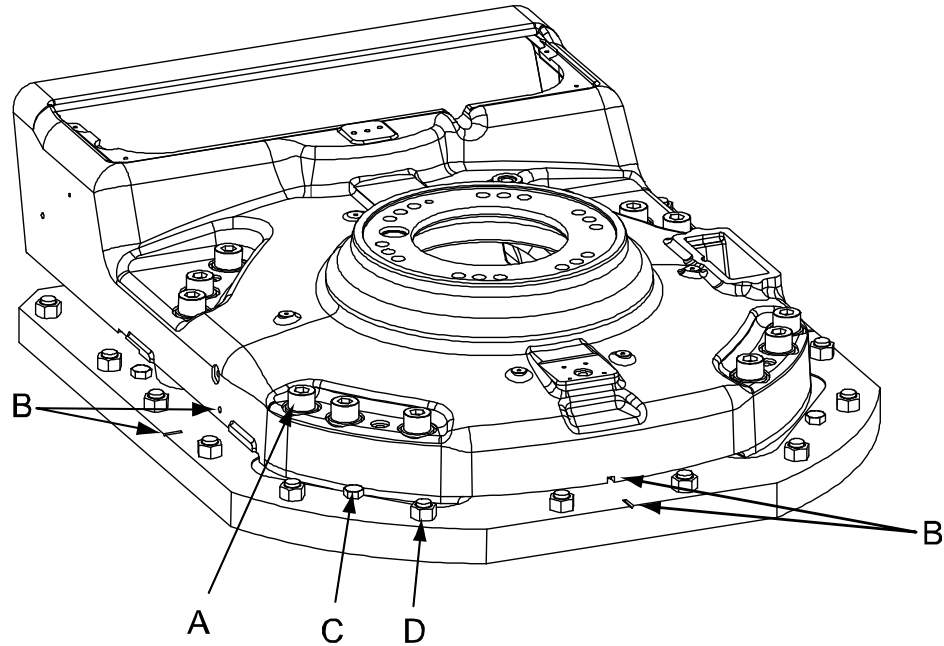

xx0100000107

A	Robot attachment bolts and washers, 12 pcs (M24 x 140)
B	Orienting grooves in the robot base and in the base plate
C	Levelling screws
D	Base plate attachment screws

Attachment screws



The table below specifies the type of securing screws and washers to be used for securing the robot to the base plate/foundation.

Suitable screws, lightly lubricated:	M24 x 140
Quality:	Quality 8.8
Suitable washer:	Thickness: 4 mm Outer diameter: 44 mm Inner diameter: 25 mm
Tightening torque:	725 Nm

Continues on next page

Securing the robot

Use this procedure to secure robot to base plate after fitting plate to the foundation.

	Action	Note
1	Lift the robot.	See section Lifting robot with lifting accessory (recommended lifting method) on page 62 . See section Lifting robot with round-slings on page 60 .
2	Move robot to the vicinity of its installation location.	
3	Fit two guide sleeves to the <i>guide sleeve holes</i> in the base plate.	Shown in figure Base plate, guide sleeve holes on page 70 .  Note One of the guide sleeve holes is elongated!
4	Guide the robot gently using two M24 screws while lowering it into its mounting position.	Make sure the robot base is correctly fitted onto the guide sleeves!
5	Fit the <i>bolts and washers</i> in the base attachment holes.	Specified in Attachment screws on page 72 . Shown in figure Illustration, robot fitted to base plate on page 72 .  Note Lightly lubricate screws before assembly!
6	Tighten bolts in a criss-cross pattern to ensure that the base is not distorted.	

Continues on next page

2 Installation and commissioning

2.3.7 Orienting and securing the robot

Continued

Hole configuration, base

This illustration shows the hole configuration used when securing the robot.

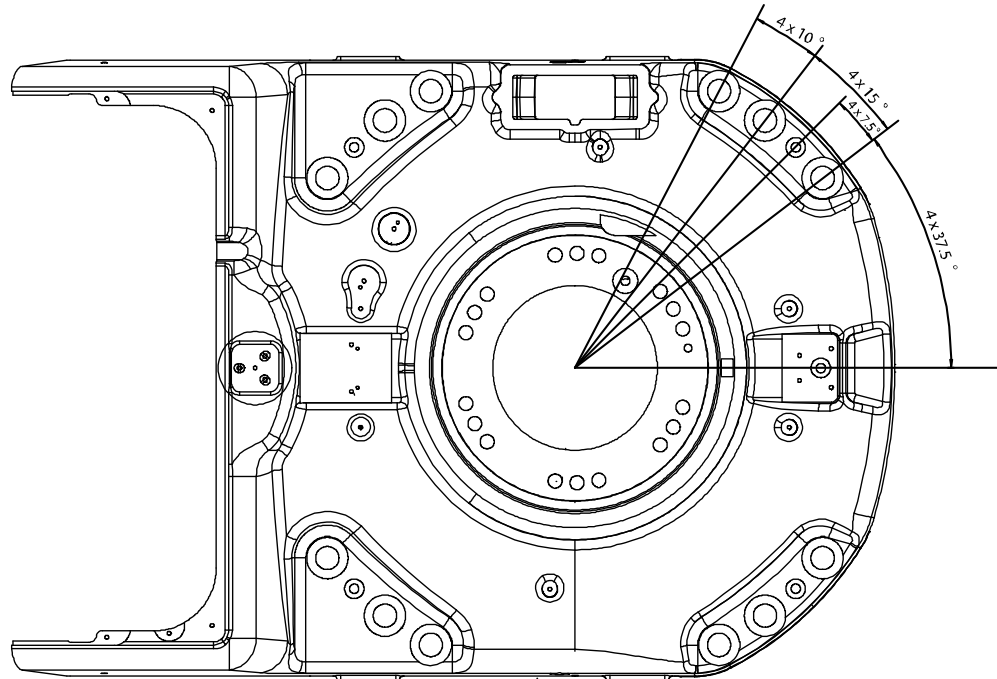

xx030000046

Cross section, guide sleeve hole

This illustration shows the cross section of the guide sleeve holes.

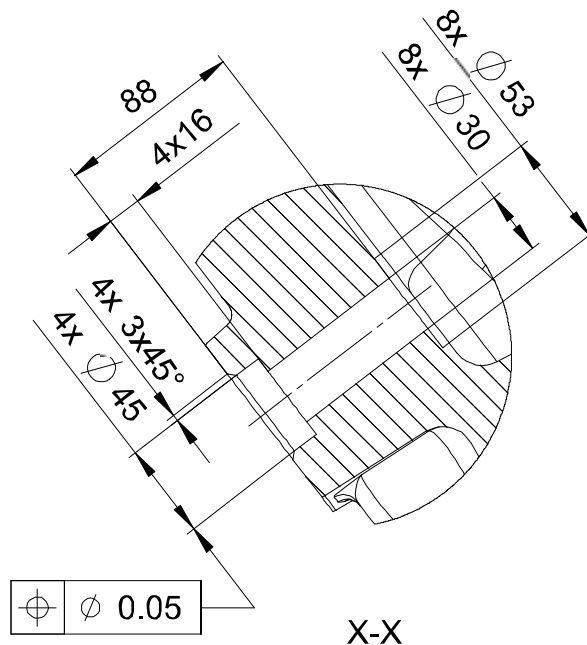

xx0600002629

2.3.8 Fitting equipment on robot

General

The robot features mounting holes for additional equipment.

Access to any of the following mounting holes may be obstructed by any additional cabling, equipment, etc., fitted by the robot user. Make sure the required mounting holes are accessible when planning the robot cell.

**Note**

All equipment and cables used on the robot, must be designed and fitted not to damage the robot and/or its parts.

**Note**

The robot IRB 6600ID, IRB 6650ID and IRB 6650ID is delivered with DressPack and there may not be any additional equipment fitted to the robot, except at the turning disc and the frame.

Illustration, fitting of extra equipment on lower arm

The illustration below shows the mounting holes available for fitting extra equipment on the lower arm.

Make sure not to damage the robot cabling on the inside of the lower arm when fitting extra equipment. Always use appropriate attachment screws!

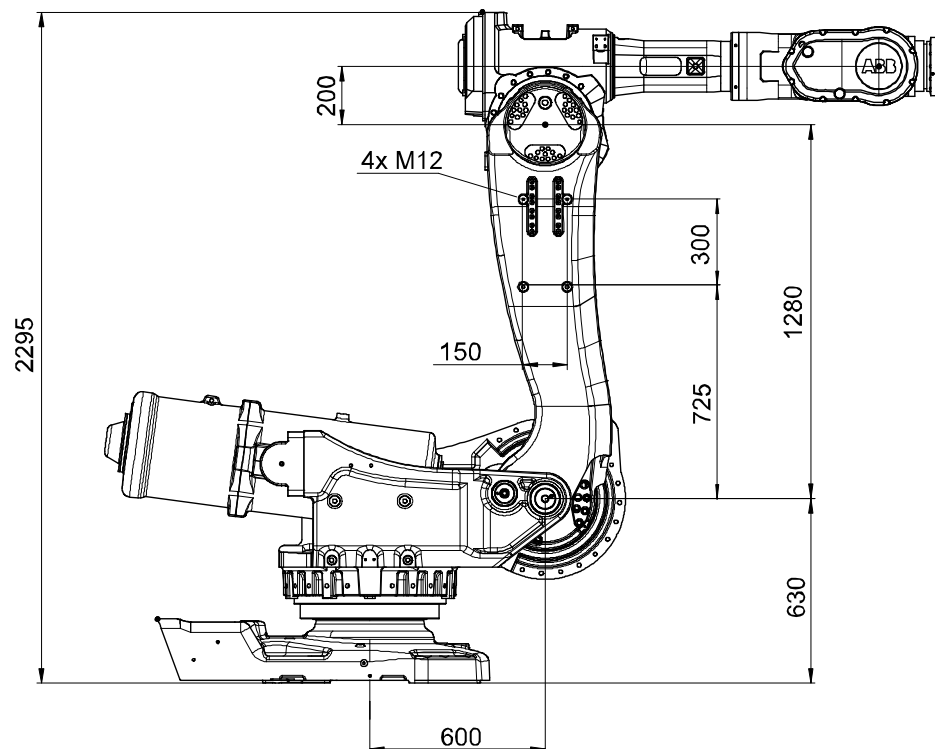

xx0300000568

Continues on next page

2 Installation and commissioning

2.3.8 Fitting equipment on robot

Continued

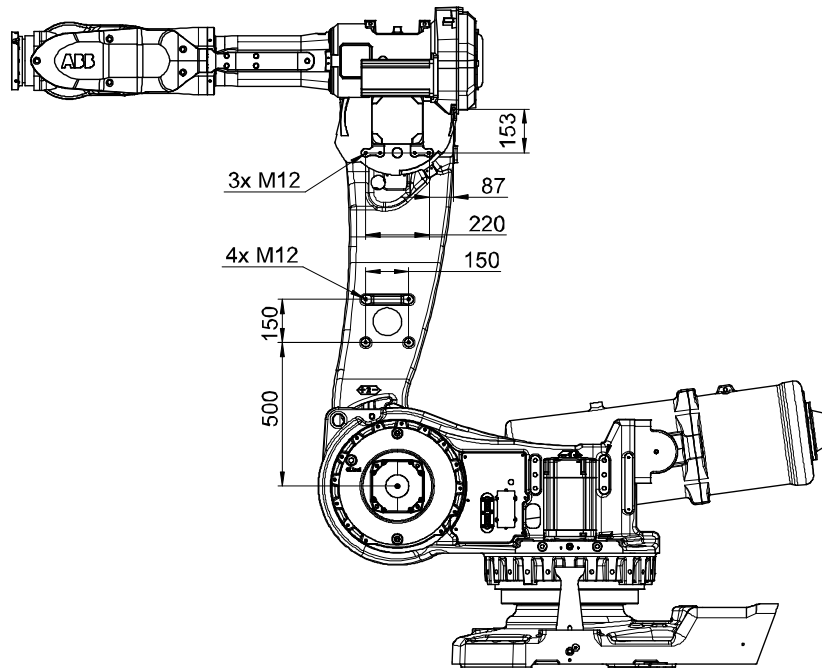

xx0300000569

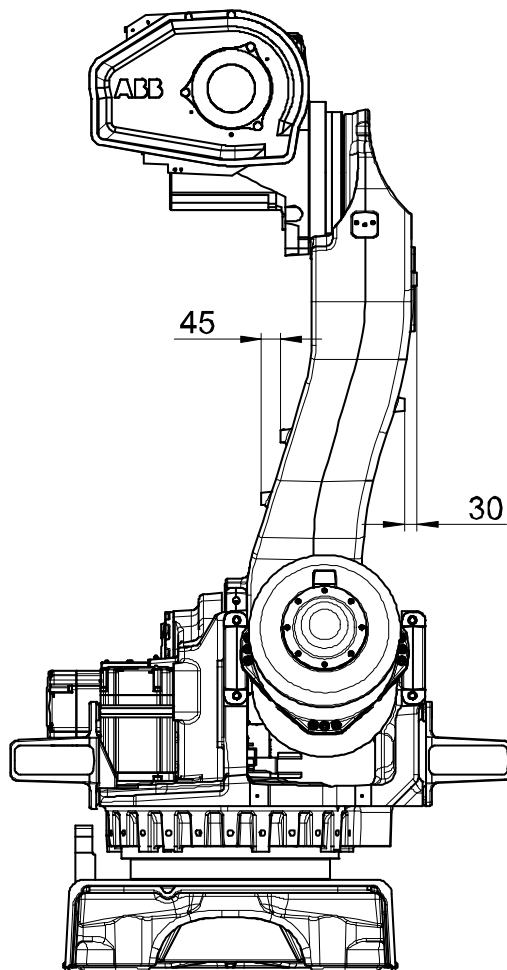

xx0300000570

Continues on next page

Illustration, fitting of extra equipment on upper arm

The illustration below shows the mounting holes available for fitting extra equipment on the upper arm.

IRB 6650S - 200/3.0: 1142
- 125/3.5: 1592
- 90/3.9: 2042

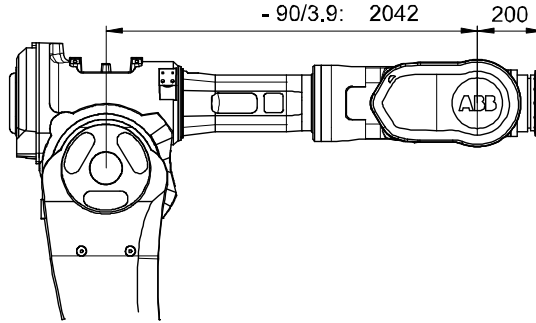

xx0300000574

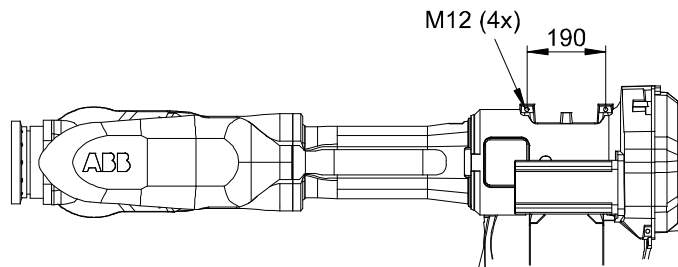

xx0200000196

-	Only valid for IRB 6600 and IRB 6650
---	--------------------------------------

2 Installation and commissioning

2.3.8 Fitting equipment on robot

Continued

Illustration, fitting of extra equipment on frame

The mounting holes available for fitting extra equipment on the frame are shown below.

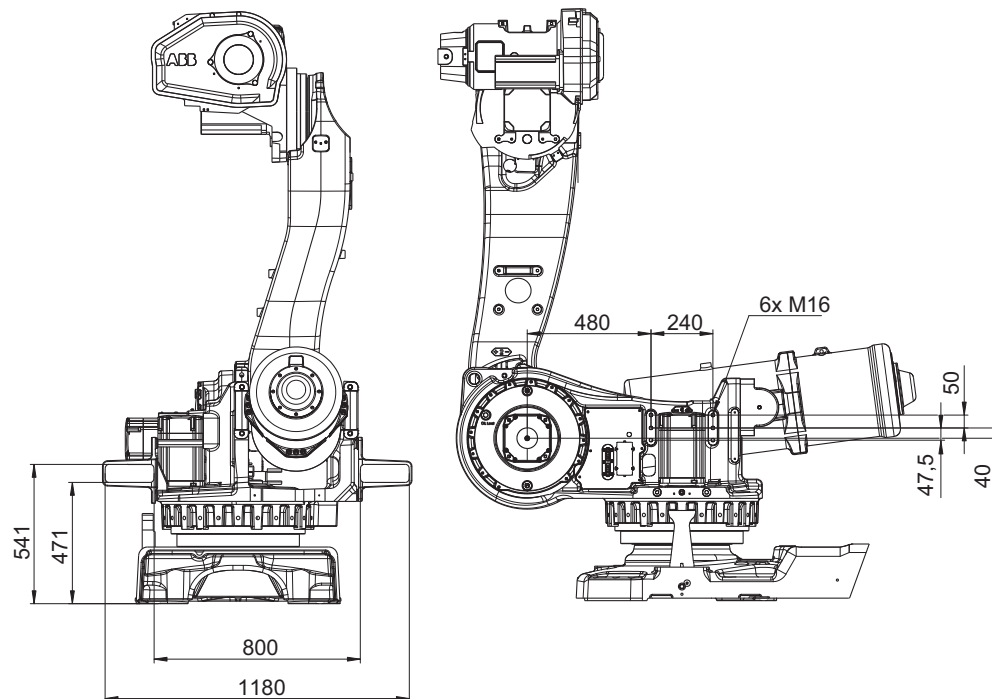

xx0300000575

Continues on next page

Tool flange, standard

The illustration below shows the mounting holes available for fitting equipment on the turning disc.

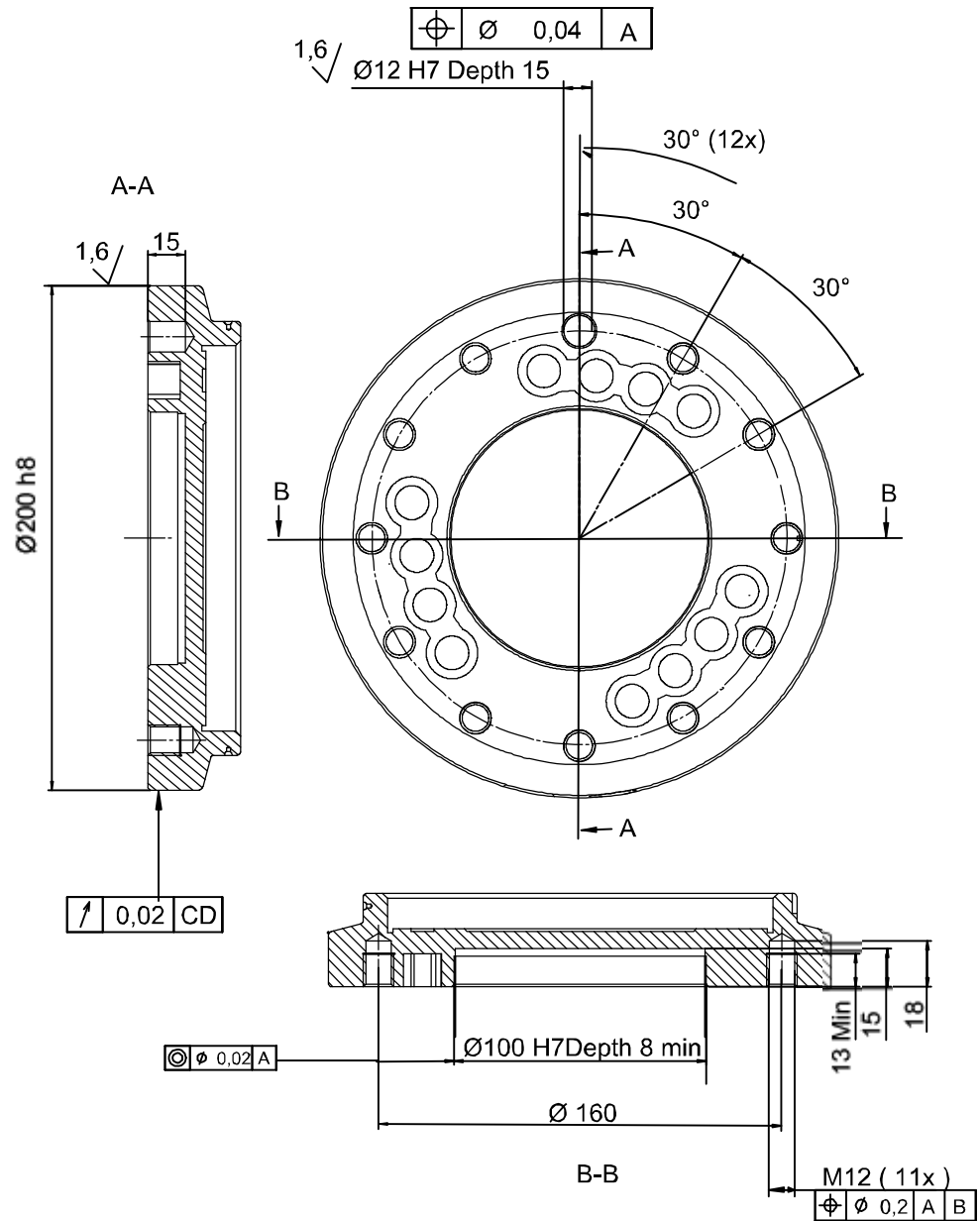

xx0200000197

Continues on next page

2 Installation and commissioning

2.3.8 Fitting equipment on robot

Continued

Tool flange, LID (LeanID)

The illustration below shows the tool flange for option LID (LeanID).

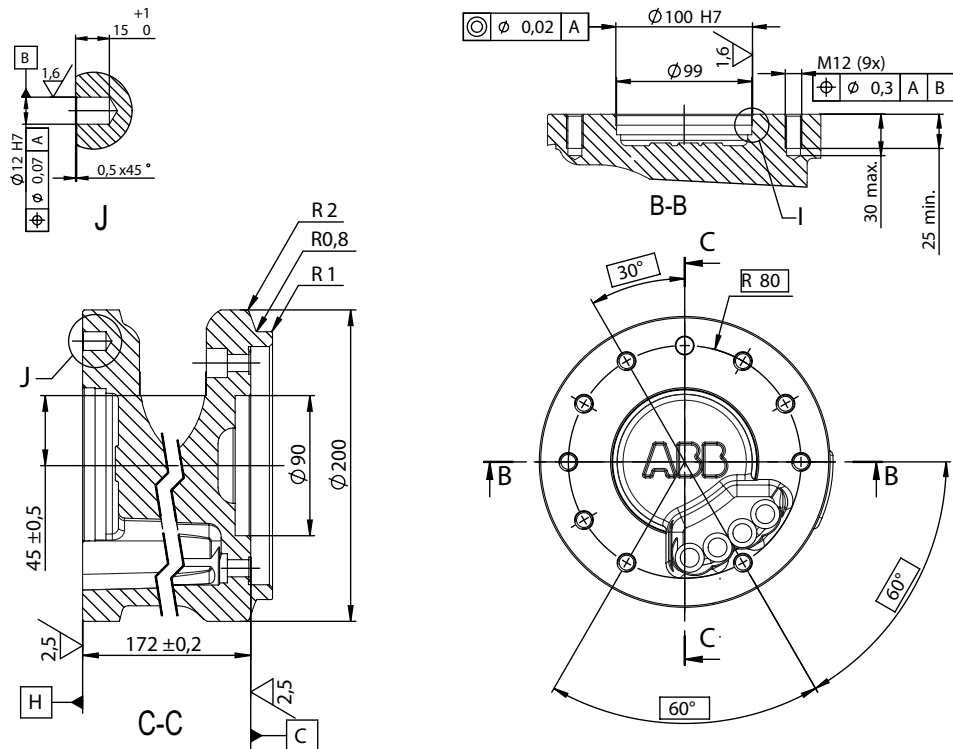

xx1600000979

Fastener quality

When fitting tools on the tool flange, only use screws with quality 12.9. For other equipment use suitable screws and tightening torque for your application.

2.3.9 Safety lamp (option for IRC5)

Description

A signal lamp with a yellow fixed light can be mounted on the robot, as a safety device.

Installation

See the assembly instruction delivered with the signal lamp.

Function

The lamp is active in MOTORS ON mode.

Further information

Further information about the MOTORS ON/MOTORS OFF mode may be found in the product manual for the controller.

2 Installation and commissioning

2.3.10 Installation of base spacers (option)

2.3.10 Installation of base spacers (option)

Illustration, installation of base spacers

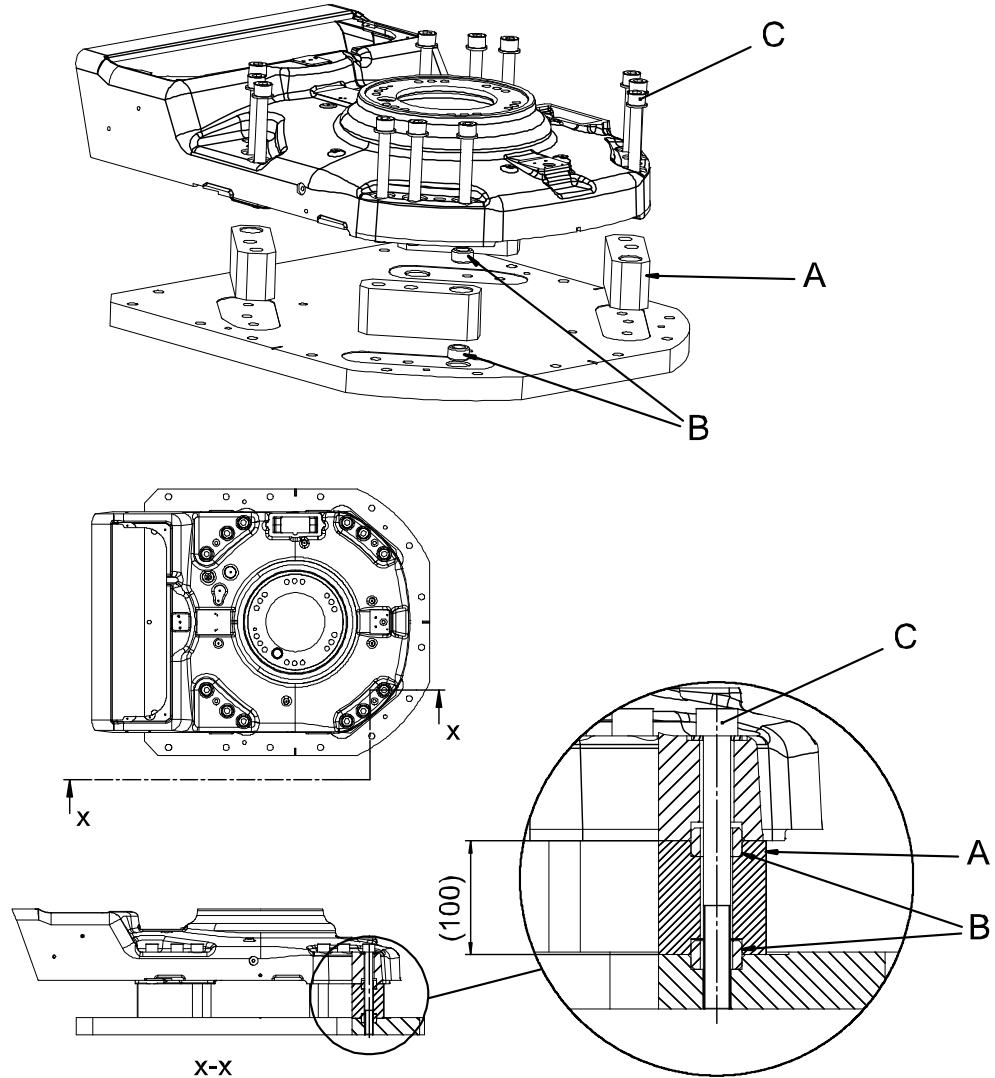

xx0500001570

A	Base spacer (4 pcs)
B	Guide sleeve (4 pcs)
C	Attachment screws and washers (8 pcs)

Required equipment



Equipment	Art. no.	Note
Base spacers	3HAC021899-002	Includes mounting set with attachment screws and mounting instruction.
Base plate	3HAC12937-8	
Standard toolkit	-	Content is defined in section Standard tools on page 406 .

Continues on next page

Equipment	Art. no.	Note
Other tools and procedures may be required. See references to these procedures in the step-by-step instructions below.		These procedures include references to the tools required.

Installation, base spacers

The procedure below details how to fit the base spacers between the robot and the base plate.

	Action	Note
1	 DANGER Turn off all: <ul style="list-style-type: none"> • electric power supply to the robot • hydraulic pressure supply to the robot • air pressure supply to the robot Before entering the robot working area.	
2	Unfasten the robot from the foundation, if fastened, and lift it away with lifting slings. Make sure the robot is positioned in the most stable position; the transport position!	Detailed in section Lifting robot with lifting accessory (recommended lifting method) on page 62.
3	Install the base plate to the foundation, if not used previously.	Detailed in section Securing the base plate on page 67.
4	Fit the four <i>base spacers</i> and <i>guiding sleeves</i> to the base plate.	Shown in the figure Illustration, installation of base spacers on page 82.
5	Lift the robot with lifting slings and move it to the prepared base plate.	
6	Guide the robot with the guiding sleeves as lowering it towards the base plate and spacers.	
7	Fasten the robot base to the spacers with enclosed attachment screws and washers.	M24 x 240, tightening torque: 775 Nm.
8	 DANGER Make sure all safety requirements are met when performing the first test run. See Test run after installation, maintenance, or repair on page 108.	

2 Installation and commissioning

2.3.11 Installation of cooling fan for motors (option)

2.3.11 Installation of cooling fan for motors (option)

General

A cooling fan can be installed on the motors of axes 1, 2 and 3.

Cooling fans for axes 1 and 2 can not be combined!

The cabling for the fans is available in different designs:

- complete cabling, including connections for cooling fans at axes 1, 2, and 3.
- separate cabling for axis 1 or 2, including only connections for the cooling fans on axes 1 or 2. Installation of this cabling is detailed in section [Installation, separate fan cabling axis 1 or 2 on page 88](#).

Location of cooling fans

The fans are installed on the motors, axes 1 or 2, as shown in the figure below.

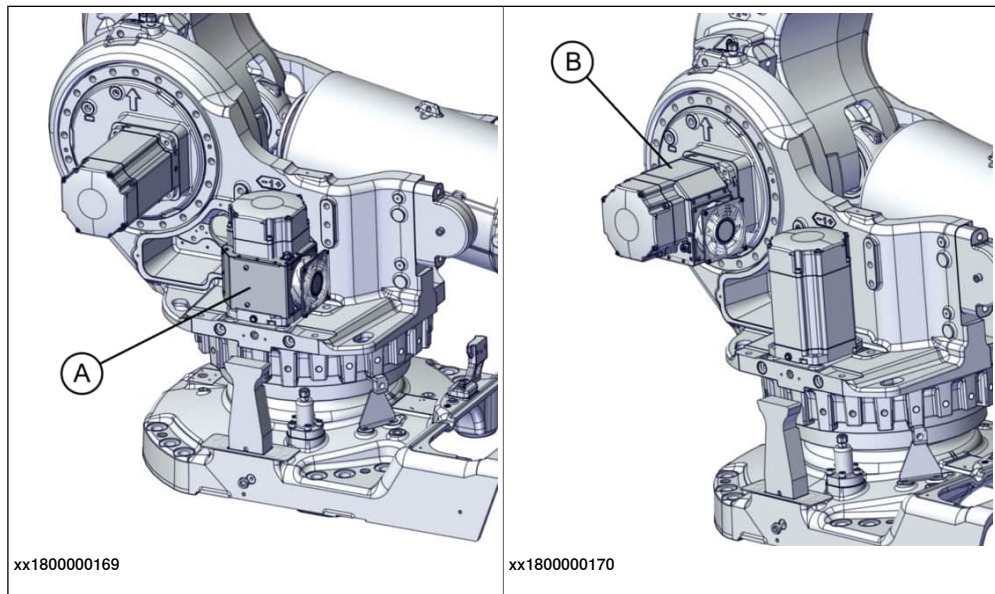

A	Cooling fan, axis 1
B	Cooling fan, axis 2

Continues on next page

Cooling fan

The details of the cooling fan are shown in the figure below.

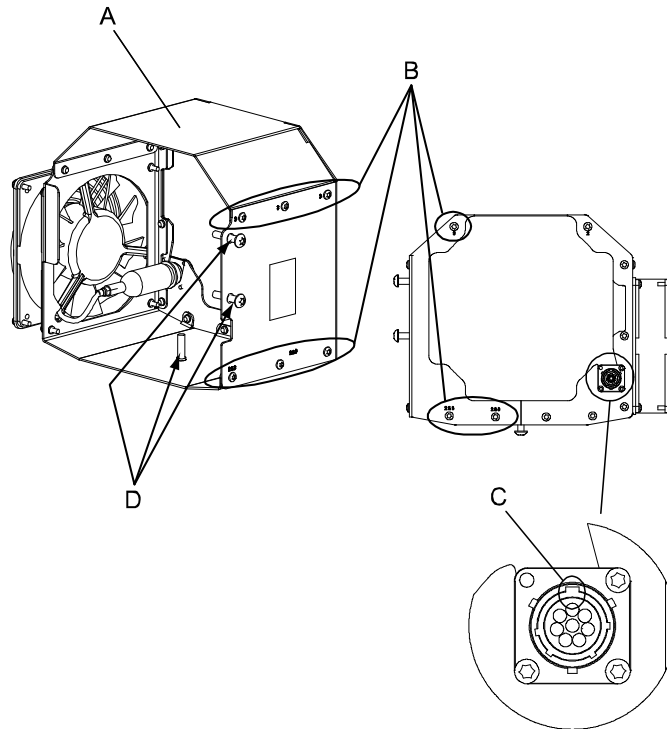

xx0500002158

A	Fanbox
B	Attachment screws, fanbox plates (9 pcs)
C	Groove in the connector
D	Tightening screws, fanbox (3 pcs)

Required equipment

Equipment	Article number	Note
Cooling fan	3HAC15374-1	
Cabling cooling fan, axes 1 or 2.	3HAC023599-001	Choose this cabling if equipping the robot with cooling fans on axis 1 or 2.
Plate for customer connections	3HAC025778-001	An additional connection plate must be fitted to the robot base, if not already installed. The plate is shown in the figure Plate for customer connections, at base on page 86 .
Additional cabling to and inside the controller	-	
Material set fan axes 1 and 2	3HAC023999-001	The set includes: <ul style="list-style-type: none"> fan axes 1 & 2 cable harness plate, customer attachment screws and nuts.
Cable harness inside controller	3HAC025488-001	

Continues on next page

2 Installation and commissioning

2.3.11 Installation of cooling fan for motors (option)

Continued

Equipment	Article number	Note
Locking liquid	-	Loctite 243. Used for the three tightening screws.
Standard toolkit	-	Content is defined in section Standard tools on page 406 .
Circuit diagram	-	See chapter Circuit diagram on page 411 .
Other tools and procedures may be required. See references to these procedures in the step-by-step instructions below.		These procedures include references to the tools required.

Plate for customer connections, at base

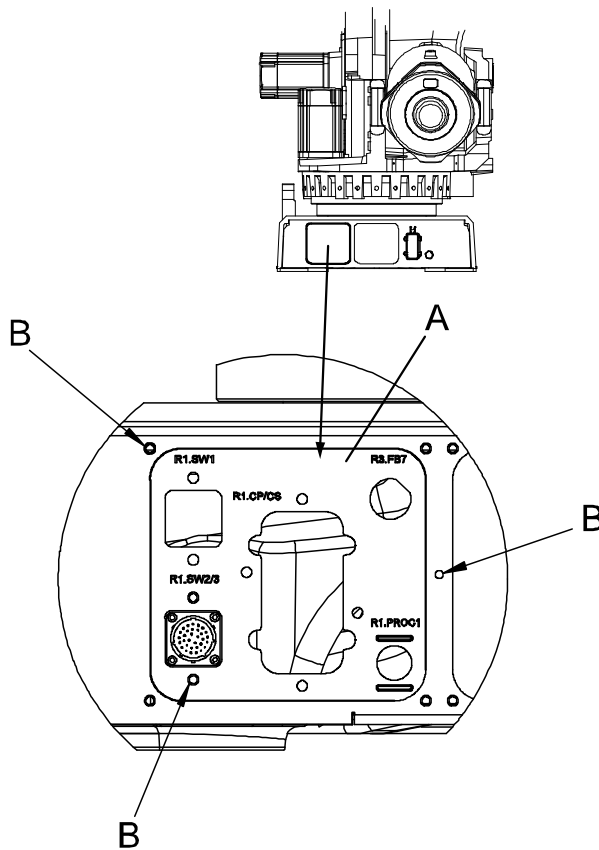

xx0500002301

A	Plate for customer connections
B	Attachment screws, 3 pcs, M6x16 quality 8.8-A2F

Continues on next page

Installation, fan

The procedure below details how to install the cooling fan on any of the motors, axes 1-3 .

	Action	Note
1	 DANGER Turn off all: <ul style="list-style-type: none"> • electric power supply to the robot • hydraulic pressure supply to the robot • air pressure supply to the robot Before entering the robot working area.	
2	Prepare the fanbox for installation: <ul style="list-style-type: none"> • disassemble the two parts of the box by removing the nine <i>attachment screws</i> • loosen the three <i>tightening screws</i>, to avoid damaging the surfaces of the motor when fitting the fanbox • turn the connector to the correct position; axis 1: groove pointing inwards, as shown in the figure Cooling fan on page 85. Positions for axis 2 and 3 are shown in the figure Location of cooling fans on page 84. 	Shown in the figure Cooling fan on page 85 .
3	Temporarily lift the motor cabling out of the way of the current motor to make room for the fanbox.	
4	Fit the parts of the fanbox to the motor and reassemble with the nine <i>attachment screws</i> .	
5	Lift the box (axis 1) so that it does not rest directly on the robot and secure the box with the three tightening screws, using locking liquid. Tighten them properly so that the box is firmly attached to the motor.	
6	Install the cabling and make adjustments in RobotWare, as described in the following procedures.	

Separate cabling for axis 1 or 2

The figure below shows the cabling used only for the fan on axis 1 or 2.

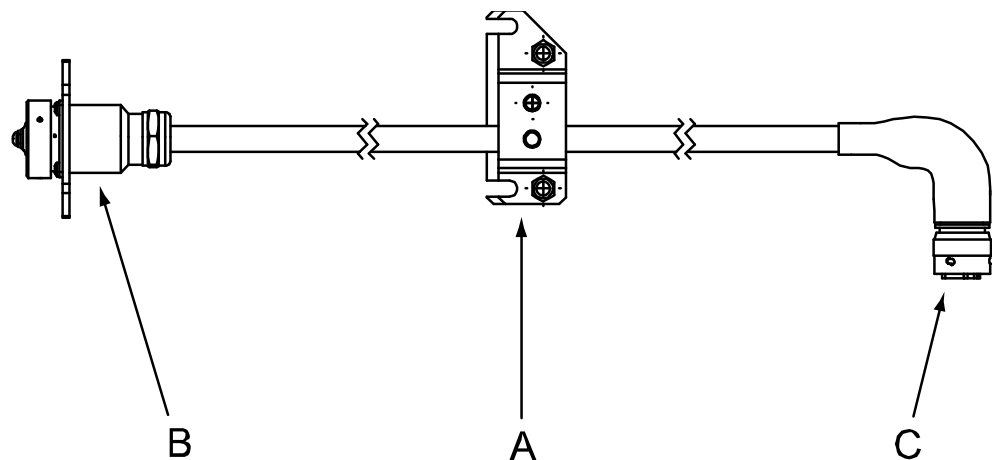

xx0500002173

Continues on next page

2 Installation and commissioning

2.3.11 Installation of cooling fan for motors (option)

Continued

A	Cable bracket
B	Connector R1.SW2/3, connected to the robot base
C	Connector R3.FAN2, connected to the fan of axis 1 or 2

Installation, separate fan cabling axis 1 or 2

The procedure below details how to install the separate cabling for the cooling fan of axis 1 or 2.

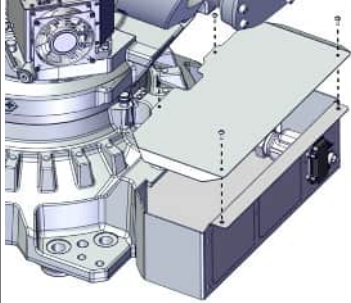
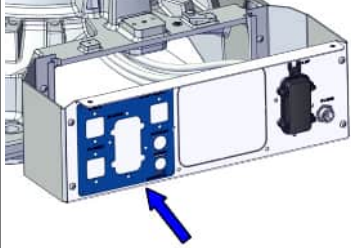

	Action	Note
1	Move the robot to its calibration position.	This is detailed in section Synchronization marks and synchronization position for axes on page 364 .
2	 DANGER Turn off all: <ul style="list-style-type: none"> • electric power supply to the robot • hydraulic pressure supply to the robot • air pressure supply to the robot Before entering the robot working area.	
3	Remove the rear cover plate from the robot base.	 xx180000161
4	Remove the cable bracket (A)	Shown in the figure Separate cabling for axis 1 or 2 on page 87
5	Fit the <i>plate for customer connections</i> , if not already fitted, to the connection plate of the robot base.	Art. no. is specified in Required equipment on page 85 .  xx180000162
6	Run the cabling up through the base and frame, beneath the balancing device.	

Continues on next page

2 Installation and commissioning

2.3.11 Installation of cooling fan for motors (option)

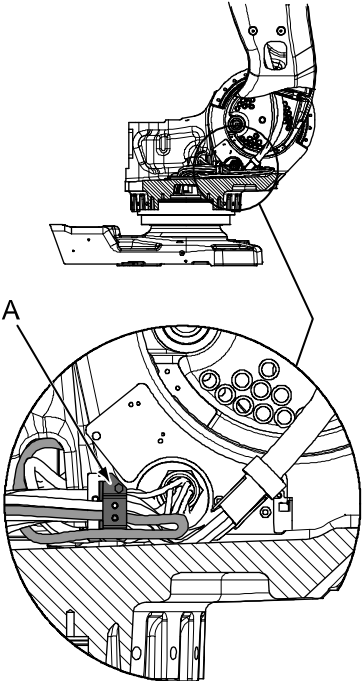
Continued

	Action	Note
7	<p>Secure the <i>cable bracket</i> to the bracket of the robot cabling inside the frame.</p> <p>Run the cable underneath the robot cabling and out through the side of the frame, at motor, axis 1 . The correct cable run is shown in the figure to the right!</p> <p> Note</p> <p>There is a risk of the balancing device damaging the cable if it is not protected by the robot cabling!</p>	 <p>xx0500002174</p> <p>A Cable bracket. Also shown in the figure Separate cabling for axis 1 or 2 on page 87.</p>
8	<p>Connect the connector R3.FAN2 to the fan of axis 1 or 2.</p>	<p> Note</p> <p>Fans on both axis 1 and 2 can not be used at the same time!</p>
9	<p>Connect the connector R1.SW2/3 to the base of the robot. Make sure that the cabling, run through the frame and base, is not twisted and runs freely from the robot cabling.</p>	
10	<p>Refit the rear cover plate to the robot base.</p>	
11	<p>Install additional cabling to and inside the controller.</p> <p>Also make adjustments in RobotWare, as described in the following procedure.</p>	

Continues on next page

2 Installation and commissioning

2.3.11 Installation of cooling fan for motors (option)

Continued

Adjustments in RobotWare

	Action	Note
1	Modify the settings in RobotWare to include the cooling fans.	<p>RobotWare 5: modify the option information in System Builder (RobotStudio). Read more about modifying the system in <i>Operating manual - RobotStudio</i>.</p> <p>RobotWare 6: modify the option information in Installation Manager (RobotStudio). Read more about modifying the system in <i>Operating manual - RobotStudio</i>.</p> <p>RobotWare 7: modify the option information in Installation Manager (RobotStudio). Read more about modifying the system in <i>Operating manual - RobotStudio</i>.</p>

2.3.12 Installation of option Foundry cable guard

Introduction

How to install the Foundry cable guard is described in the instruction delivered with the cable guard.

Separate instructions for IRB 2600, 4600, 6620, 6640, 6650S, 6660 and 7600 are available in English, German, French, Spanish and Italian and can be found for registered users on myABB Business Portal (www.abb.com/myABB) and delivered with the Cable guard, article number 3HAC035933-001.

2 Installation and commissioning

2.3.13 Loads fitted to the robot, stopping time and braking distances

2.3.13 Loads fitted to the robot, stopping time and braking distances

General

Any loads mounted on the robot must be defined correctly and carefully (with regard to the position of center of gravity and mass moments of inertia) in order to avoid jolting movements and overloading motors, gears and structure.



CAUTION

Incorrectly defined loads may result in operational stops or major damage to the robot.

References

Load diagrams, permitted extra loads (equipment) and their positions are specified in the product specification. The loads must be defined in the software.

- *Operating manual - IRC5 with FlexPendant*
- *Operating manual - OmniCore*

Stopping time and braking distances

The performance of the motor brake depends on if there are any loads attached to the robot. For more information, see product specification listed in [References on page 10](#).

2.4 Restricting the working range

2.4.1 Axes with restricted working range

General

When installing the robot, make sure that it can move freely within its entire working space. If there is a risk that it may collide with other objects, its working space should be limited.

The working range of the following axes may be restricted:

- Axis 1, hardware (mechanical stop)
- Axis 2, hardware (mechanical stop)
- Axis 3, hardware (mechanical stop)

This section describes how to install hardware that restricts the working range.



Note

Adjustments must also be made in the robot configuration software (system parameters). References to relevant manuals are included in the installation procedures.

2 Installation and commissioning

2.4.2 Mechanically restricting the working range of axis 1

2.4.2 Mechanically restricting the working range of axis 1

General

The working range of axis 1 is limited by fixed mechanical stops and adjustment of the system parameter configuration. The working range can be reduced by adding additional mechanical stops giving 7.5 or 15 graduation, between 22.5° and 135° in both directions.

Mechanical stops, axis 1

The illustration shows the mounting position of the stop pin and one of the additional mechanical stops available for axis 1.

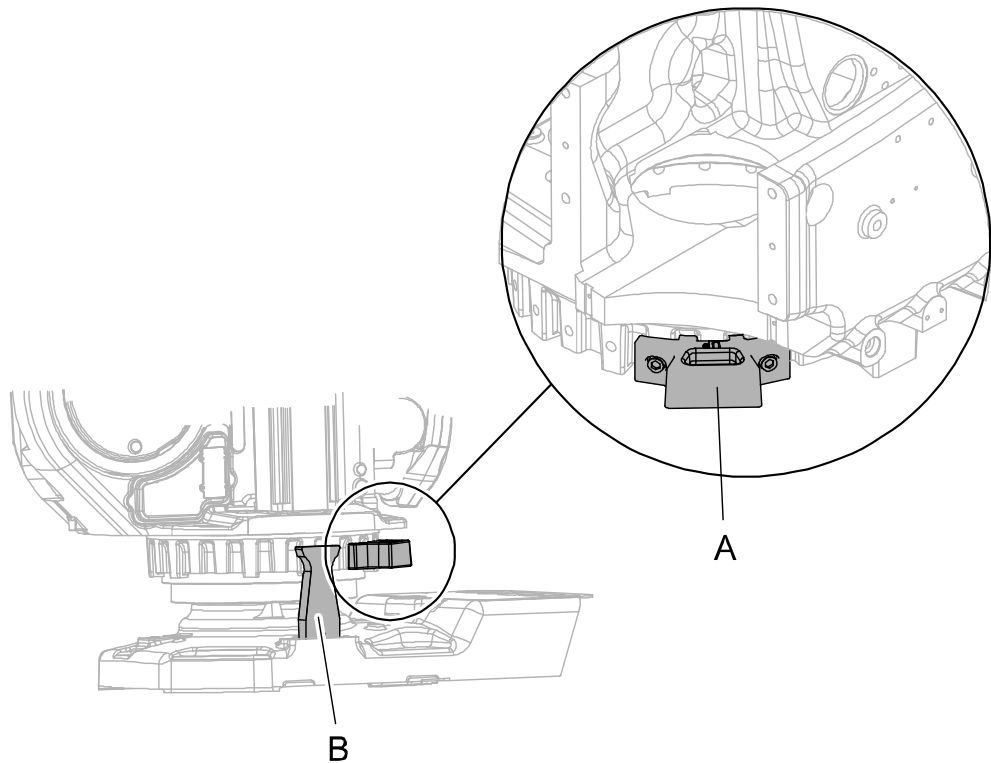

xx0300000049

A	Additional mechanical stop
B	Stop pin



Required equipment

Equipment, etc.	Article number	Note
Mechanical stop for axis 1, 7.5°	3HAC11076-1	Includes attachment screws and an assembly drawing.
Mechanical stop for axis 1, 15°	3HAC11076-2	Includes attachment screws and an assembly drawing.
Standard toolkit	-	
<i>Technical reference manual - System parameters</i>	-	Article number is specified in section References on page 10 .

Continues on next page

Installation, mechanical stops axis 1

Use this procedure to fit the additional mechanical stops to axis 1 of the robot. An assembly drawing is also enclosed with the product.

	Action	Note
1	 DANGER Turn off all: <ul style="list-style-type: none"> • electric power supply to the robot • hydraulic pressure supply to the robot • air pressure supply to the robot Before entering the robot working area.	
2	Fit the additional mechanical stop to the frame according to the figure Mechanical stops, axis 1 on page 94 .	Tightening torque: 120 Nm.
3	Adjust the software working range limitations (system parameter configuration) to correspond to the mechanical limitations.	The system parameters that must be changed (<i>Upper joint bound</i> and <i>Lower joint bound</i>) are described in <i>Technical reference manual - System parameters</i> .
4	 WARNING If the mechanical stop pin is deformed after a hard collision, it must be replaced! Deformed <i>movable stops</i> and/or <i>additional stops</i> as well as deformed <i>attachment screws</i> must also be replaced after a hard collision.	

2 Installation and commissioning

2.4.3 Extended working range, axis 1 (option)

2.4.3 Extended working range, axis 1 (option)

Overview

The working range of axis 1 can be extended on a floor-mounted robot, from the default range limited by mechanical stops. The working range can be extended to $\pm 220^\circ$.



CAUTION

The option *Extended work range* enables an extension of the working range for axis 1, through a software configuration. With this option installed, the working range can exceed the range limited by the mechanical stop on axis 1. The working range shall be limited through the option *SafeMove*.

A risk analysis must be done to ensure that no risks remain when using option *Extended work range*, to limit the working range, and before removing the mechanical stops.

For information about the option *SafeMove*, see *Application manual - Functional safety and SafeMove2 (IRC5)* or *Application manual - Functional safety and SafeMove (OmniCore)*.

If the mechanical stop is removed, then the manipulator should have a marking for this, for example, a label. If the robot is delivered with the option *Extended work range*, then such a label is included on delivery.

Extending the working range

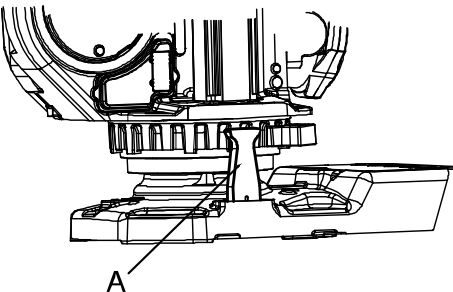
	Action	Note/Illustration
1	Configure the safety setup and verify it by test.	
2	Hold the mechanical stop pin in a firm grip, and remove it by unscrewing the attachment screw.	 xx0400001034
3	In RobotWare, redefine the working range limitations in the system parameters, topic <i>Motion</i> . The <i>Arm</i> parameters <i>Upper Joint Bound</i> and <i>Lower Joint Bound</i> can be changed to the values corresponding to the actual installation.	With the option <i>Extended working range</i> , the maximum value for the system parameters <i>Upper Joint Bound</i> and <i>Lower Joint Bound</i> is 3.84 respectively -3.84. The values are in radians, that is 3.84 radians = 220 degrees.

Related information

The system parameters are described in detail in the reference manual, see [References on page 10](#).

Continues on next page

For more information about SafeMove, see *Application manual - Functional safety and SafeMove2 (IRC5)* or *Application manual - Functional safety and SafeMove (OmniCore)*.

2 Installation and commissioning

2.4.4 Mechanically restricting the working range of axis 2

2.4.4 Mechanically restricting the working range of axis 2

General

The working range of axis 2 is limited by fixed mechanical stops and can be reduced by adding up to six additional mechanical stops with 15 graduation in respective direction.

Mechanical stops, axis 2

The illustration shows the mounting position of the mechanical stops on axis 2.

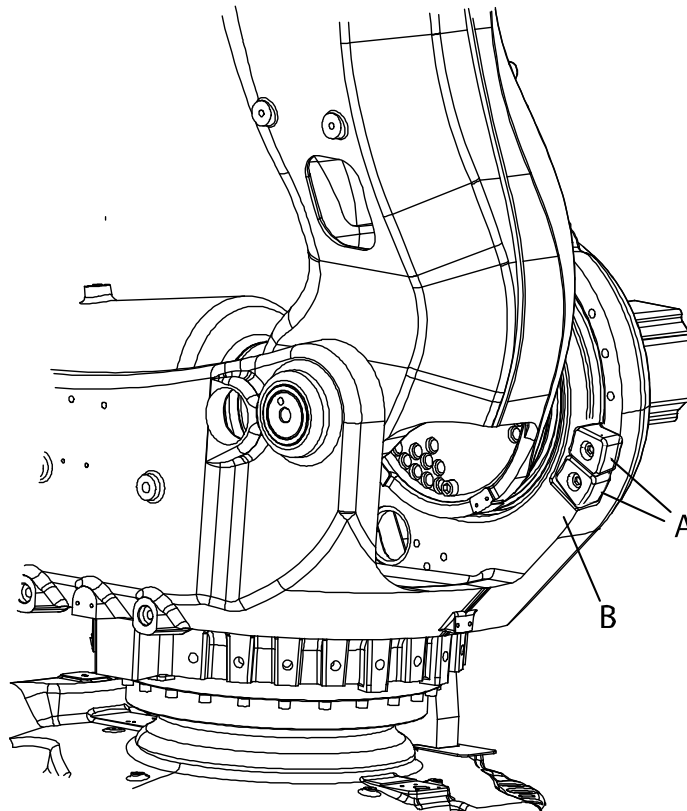

xx0300000047

A	Additional mechanical stops
B	Fixed mechanical stop



Required equipment

Equipment, etc.	Art. no.	Note
Mechanical stop set, axis 2	3HAC13787-1	Includes six stops, attachment screws, washers and assembly drawings.
Standard toolkit	-	Content is defined in section Standard tools on page 406 .
<i>Technical reference manual - System parameters</i>	-	Art. no. is specified in section References on page 10 .

Continues on next page

Installation, mechanical stops axis 2

Use the procedure to fit the mechanical stops for axis 2 to the robot. An assembly drawing is also enclosed with the product.

	Action	Note
1	 DANGER Turn off all: <ul style="list-style-type: none"> • electric power supply to the robot • hydraulic pressure supply to the robot • air pressure supply to the robot Before entering the robot working area.	
2	Fit and tighten the additional stops in a row, starting from the fixed stop.	Tightening torque: 115 Nm. Shown in the figure Mechanical stops, axis 2 on page 98 .
3	The software working range limitations must be redefined to correspond to the changes in the mechanical limitations of the working range.	The system parameters that must be changed (<i>Upper joint bound</i> and <i>Lower joint bound</i>) are described in <i>Technical reference manual - System parameters</i> .
4	 WARNING If the <i>mechanical stop pin</i> is deformed after a hard collision, it must be replaced! Deformed <i>movable stops</i> and/or <i>additional stops</i> as well as deformed <i>attachment screws</i> must also be replaced after a hard collision.	

2 Installation and commissioning

2.4.5 Mechanically restricting the working range of axis 3

2.4.5 Mechanically restricting the working range of axis 3

General

The working range of axis 3 is limited by fixed mechanical stops and can be reduced by adding additional mechanical stops with 20 graduation in respective direction.

Mechanical stops, axis 3

The illustration shows the mounting position of the mechanical stops on axis 3. The figure shows IRB 7600 but the principle is the same.

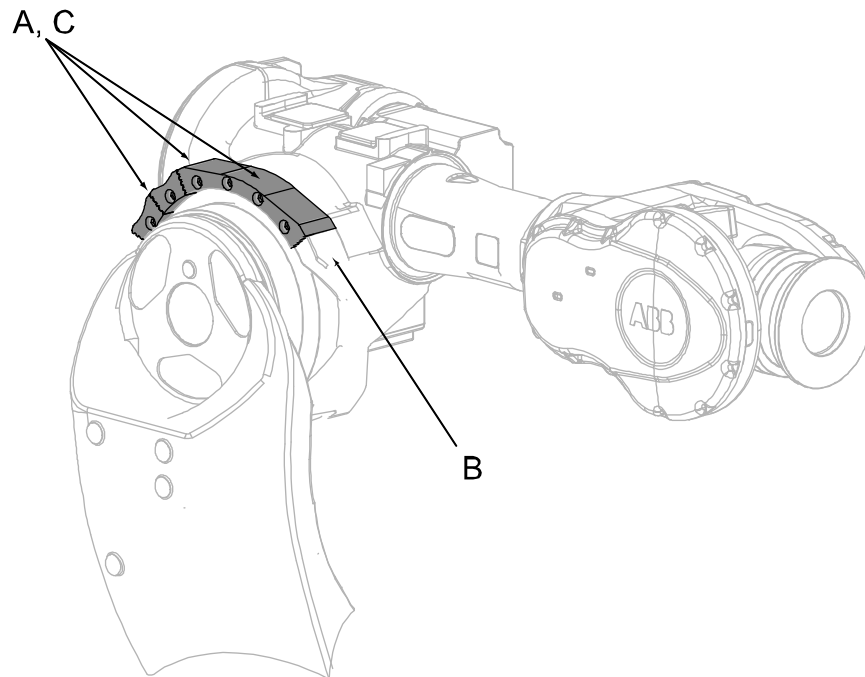

xx030000048

A	Additional mechanical stops
B	Fixed mechanical stop
C	Attachment screw M16x60 quality 12.9

Continues on next page

2 Installation and commissioning

2.4.5 Mechanically restricting the working range of axis 3

Continued

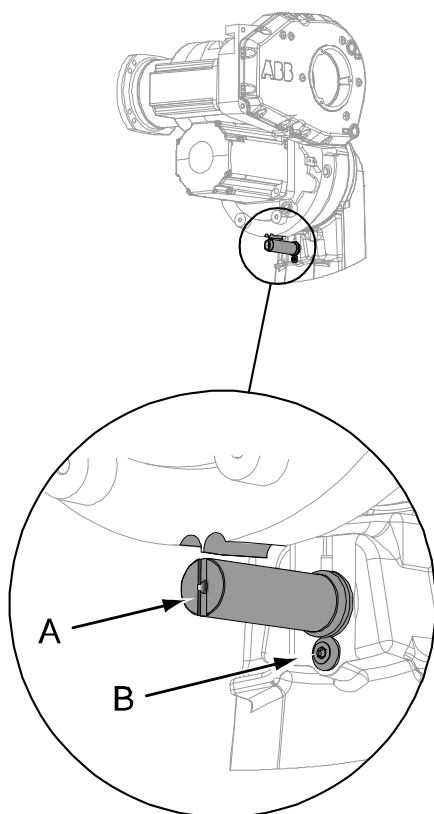

xx0600002973

A	Mechanical stop pin, axis 3
B	Attachment screw and washer

Required equipment

Equipment, etc.	Art. no.	Note
Mechanical stop set, axis 3	3HAC13128-1	Includes: <ul style="list-style-type: none">• six stops, one with 80° restriction, 3HAC12708-3 (use when limitation angle ≥ 80), and five with 20°, 3HAC12708-1.• attachment screws.
Standard toolkit	-	Content is defined in section Standard tools on page 406 .
<i>Technical reference manual - System parameters</i>	-	Art. no. is specified in section References on page 10 .

Continues on next page



2 Installation and commissioning

2.4.5 Mechanically restricting the working range of axis 3

Continued

Installation, mechanical stops axis 3

Use the procedure to fit the mechanical stops for axis 3 to the robot. An assembly drawing is also enclosed with the product.

	Action	Note
1	 DANGER Turn off all: <ul style="list-style-type: none">• electric power supply to the robot• hydraulic pressure supply to the robot• air pressure supply to the robot Before entering the robot working area.	
2	Fit and tighten the additional stops in a row, starting from the fixed stop.	Tightening torque: 115 Nm. Shown in the figure Mechanical stops, axis 3 on page 100
3	 Note The software working range limitations (system parameters) must be redefined to correspond to the changes in the mechanical limitations of the working range.	The system parameters that must be changed (<i>Upper joint bound</i> and <i>Lower joint bound</i>) are described in <i>Technical reference manual - System parameters</i> .
4	 WARNING If the <i>mechanical stop pin</i> is deformed after a hard collision, it must be replaced! Deformed <i>movable stops</i> and/or <i>additional stops</i> as well as deformed <i>attachment screws</i> must also be replaced after a hard collision.	

2.5 Electrical connections

2.5.1 Robot cabling and connection points

Introduction

Connect the robot and controller to each other after securing them to the foundation. The lists below specify which cables to use for each respective application.



CAUTION

Connect the male and female connectors perfectly aligned horizontally to avoid any kind of tilt or skew.



CAUTION

Verify that the robot serial number is according to the number(s) in the *Declaration of Incorporation (DoI)*.

Main cable categories

All cables between the robot and controller are divided into the following categories:

Cable category	Description
Robot cables	Handles power supply to and control of the robot's motors as well as feedback from the serial measurement board. Specified in the table Robot cables on page 104 .
Fan cables (option)	Handles supply to and feedback from any cooling fan on the robot. Specified in the table Fan cables (option) on page 105 .
Customer cables (option)	Handles communication with equipment fitted on the robot by the customer, low voltage signals and high voltage power supply + protective ground. The customer cables also handle databus communication. See the product manual for the controller, see document number in References on page 10 .
External axes cables (option)	Handles power supply to and control of the external axes' motors as well as feedback from the servo system. See <i>Application manual - Additional axes and standalone controller (IRC5)</i> or <i>Application manual - Additional axes for OmniCore (OmniCore)</i> , document number in References on page 10 .
DressPack cables (option)	Handles signals, process media and power feeding for customer use, regarding material handling or spot welding. See the <i>Product manual - DressPack/SpotPack IRB 6650S/7600</i> , see document number in References on page 10 .

Continues on next page

2 Installation and commissioning

2.5.1 Robot cabling and connection points

Continued

Robot cables

These cables are included in the standard delivery. They are completely pre-manufactured and ready to plug in.

Cable sub-category	Description	Connection point, cabinet	Connection point, robot
Robot cable, power	Transfers drive power from the drive units in the control cabinet to the robot motors.	XS1 (IRC5 controllers) X1 (OmniCore controllers)	R1.MP
Robot cable, signals	Transfers resolver data from and power supply to the serial measurement board.	XS2 (IRC5 controllers) X2 (OmniCore controllers)	R1.SMB

Robot cable, power

Cable	Art. no.
Robot cable, power: 7 m	3HAC026787-001
Robot cable, power: 15 m	3HAC026787-002
Robot cable, power: 22 m	3HAC026787-003
Robot cable, power: 30 m	3HAC026787-004

Robot cable, signals

Cable	Art. no.
Robot cable signal, shielded: 7 m	3HAC7998-1
Robot cable signal, shielded: 15 m	3HAC7998-2
Robot cable signal, shielded: 22 m	3HAC7998-3
Robot cable signal, shielded: 30 m	3HAC7998-4

Bending radius for static floor cables

The minimum bending radius is 10 times the cable diameter for static floor cables.

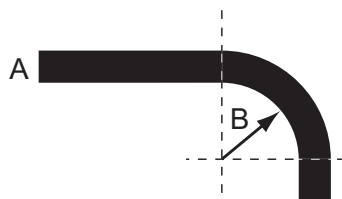

xx1600002016

A	Diameter
B	Diameter x10

Continues on next page

Grounding and bonding point on manipulator

There is a grounding/bonding point on the manipulator base. The grounding/bonding point is used for potential equalizing between control cabinet, manipulator and any peripheral devices.

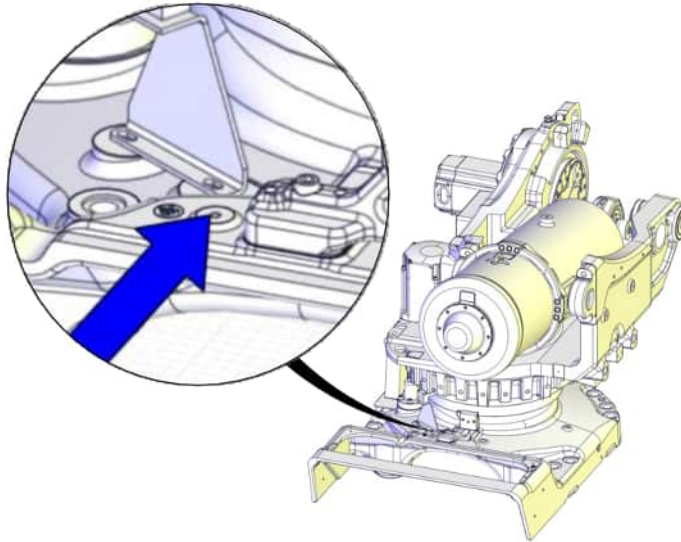

xx1500001599



Note

How to ground DressPack/SpotPack cables is detailed in the *Product manual - DressPack/SpotPack IRB 6650S/7600*, see the document number in [References on page 10](#).

Fan cables (option)

These cables are *not* included in the standard delivery, but are included in the delivery if the fan option is ordered. The cables are completely pre-manufactured and ready to plug in.

Cabling to be installed on the robot is specified in section [Installation of cooling fan for motors \(option\) on page 84](#).

Cabling between robot base and control cabinet, cooling fans, M2004

The cables specified below are specific for the IRC5 controller and used when the robot is equipped with cooling fans. The cabling for the cooling fans runs all the way from the robot base to the inside of the cabinet. Fans can also be ordered without cables.

If equipping the robot with cooling fans, use the cabling specified below. The cables for cooling fans listed below are used together with a distributing cable, also specified below.

Cable	Art. no.	Connection point
Harness - cooling, 7 m	3HAC022723-001	Distributing cable: R1.FAN.SW2/3 Inside cabinet: A43.X10 and A43.X11

Continues on next page

2 Installation and commissioning

2.5.1 Robot cabling and connection points

Continued

Cable	Art. no.	Connection point
Harness - cooling, 15 m	3HAC022723-004	Distributing cable: R1.FAN.SW2/3 Inside cabinet: A43.X10 and A43.X11
Harness - cooling, 22 m	3HAC022723-005	Distributing cable: R1.FAN.SW2/3 Inside cabinet: A43.X10 and A43.X11
Harness - cooling, 30 m	3HAC022723-006	Distributing cable: R1.FAN.SW2/3 Inside cabinet: A43.X10 and A43.X11

2.6 Start of robot in cold environments

Introduction

This section describes how to start the robot in a cold environment if it is not starting the normal way.

Problems with starting the robot

Event message from Motion Supervision

Use this procedure if an event message indicates a problem with Motion supervision at start-up. More information about Motion Supervision is found in *Technical reference manual - System parameters*.

	Action	Note
1	Turn off Motion Supervision.	
2	Start the robot.	
3	When the robot has reached normal working temperature, the Motion Supervision can be turned on again.	

Robot stopping with other event message

Use this procedure if the robot is not starting.

	Action	Note
1	Start the robot with its normal program but with reduced speed.	The speed can be regulated with the RAPID instruction <code>VelSet</code> .

Adjusting the speed and acceleration during warm-up

Depending on how cold the environment is and what program is being used, the speed might need to be ramped up until reached maximum. The table shows examples of how to adjust the speed:

Work cycles	AccSet	Speed/velocity
3 Work cycles	20, 20	v100 (100 mm/s)
5 Work cycles	40, 40	v400 (400 mm/s)
5 Work cycles	60, 60	v600 (600 mm/s)
5 Work cycles	100, 100	v1000 (1000 mm/s)
More than 5 Work cycles	100, 100	Max.

If the program consists of large wrist movements, it is possible that the reorientation velocity, which is always high in predefined velocities, needs to be included in the ramping up.

2 Installation and commissioning

2.7 Test run after installation, maintenance, or repair

2.7 Test run after installation, maintenance, or repair

Safe handling

Use the following procedure after installation, maintenance, or repair, before initiating motion.



DANGER

Initiating motion without fulfilling the following aspects, may increase the risk for injury or cause damage to the robot.

	Action
1	Remove all tools and foreign objects from the robot and its working area.
2	Verify that the robot is properly secured to its position by all screws, before it is powered up.
3	Verify that any safety equipment installed to secure the position or restrict the robot motion during service activity is removed.
4	Verify that the fixture and work piece are well secured, if applicable.
5	Verify that all safety equipment is installed, as designed for the application.
6	Verify that no personnel are inside the safeguarded space.
7	If maintenance or repair has been done, verify the function of the part that was maintained.
8	Verify the application in the operating mode manual reduced speed.

Collision risks



CAUTION

When programming the movements of the robot, always identify potential collision risks before initiating motion.

3 Maintenance

3.1 Introduction

Structure of this chapter

This chapter describes all the maintenance activities recommended for the IRB 6650S.

It is based on the maintenance schedule found at the beginning of the chapter. The schedule contains information about required maintenance activities including intervals, and refers to procedures for the activities.

Each procedure contains all the information required to perform the activity, including required tools and materials.

The procedures are gathered in different sections and divided according to the maintenance activity.

Safety information

Observe all safety information before conducting any service work.

There are general safety aspects that must be read through, as well as more specific safety information that describes the danger and safety risks when performing the procedures. Read the chapter [Safety on page 21](#) before performing any service work.

The maintenance must be done by qualified personnel in accordance with the safety requirements set forth in the applicable national and regional standards and regulations.



Note

If the IRB 6650S is connected to power, always make sure that the IRB 6650S is connected to protective earth and a residual current device (RCD) before starting any maintenance work.

For more information see:

- *Product manual - OmniCore V250XT*
- *Product manual - IRC5*
- *Product manual - IRC5 Panel Mounted Controller*
- [Robot cabling and connection points on page 103.](#)

3 Maintenance

3.2.1 Specification of maintenance intervals

3.2 Maintenance schedule and expected component life

3.2.1 Specification of maintenance intervals

Introduction

The intervals are specified in different ways depending on the type of maintenance activity to be carried out and the working conditions of the IRB 6650S:

- Calendar time: specified in months regardless of whether the system is running or not.
- Operating time: specified in operating hours. More frequent running means more frequent maintenance activities.
- SIS: specified by the robot's SIS (Service Information System). A typical value is given for a typical work cycle, but the value will differ depending on how hard each part is run.

The SIS used in M2004 is further described in the *Operating manual - Service Information System (IRC5)* or *Operating manual - OmniCore*.

The SIS used in OmniCore is further described in the *Operating manual - OmniCore*.

Robots with the functionality *Service Information System* activated can show active counters in the device browser in RobotStudio, or on the FlexPendant.

Overhaul

Depending on application and operational environment a complete overhaul may be necessary in average around 40000 hours.

ABB Connected Services and its Assessment tools can help you to identify the real stress level of your robot, and define the optimal ABB support to maintain your robot working.

Contact your local ABB Customer Service to get more information.

3.2.2 Maintenance schedule

General

The robot must be maintained regularly to ensure proper function. The maintenance activities and intervals are specified in the following table.

Non-predictable situations also give rise to inspections of the robot. Any damage must be attended to immediately.

The inspection intervals *do not* specify the life of each component. Values for these are specified in the section [Expected component life on page 114](#)

Instructions for how to perform the different maintenance activities are found in sections:

- [Inspection activities on page 115](#)
- [Replacement/changing activities on page 153](#)
- [Cleaning activities on page 179](#)

Activities and intervals, standard equipment

The following table specifies the required maintenance activities and intervals.

Maintenance activity	Equipment	Interval	Detailed in section
Cleaning	Robot	-	<ul style="list-style-type: none"> • Cleaning the IRB 6650S on page 179
Inspection	Motor seal ⁱ	Every: <ul style="list-style-type: none"> • 12 months 	Inspecting the motor seal on page 115
Inspection	Oil level in axis-1 gearbox	Every: 12 months	Inspecting the oil level in axis-2 gearbox on page 119
Inspection	Oil level in axis-2 gearbox	Every: 12 months	Inspecting the oil level in axis-2 gearbox on page 119
Inspection	Oil level in axis-3 gearbox	Every: 12 months	Inspecting the oil level in axis-3 gearbox on page 121
Inspection	Oil level in axis-4 gearbox	Every: 12 months	Inspecting the oil level in axis-4 gearbox on page 124
Inspection	Oil level in axis-5 gearbox	Every: 12 months	Inspecting the oil level in axis-5 gearbox on page 126
Inspection	Oil level in axis-6 gearbox	Every: 12 months	Inspecting the oil level in axis-6 gearbox on page 128
Inspection	Balancing device	Every: <ul style="list-style-type: none"> • 6 months 	<ul style="list-style-type: none"> • Inspecting the balancing device on page 133
Inspection	Robot harness	Every: 12 months ⁱⁱ	<ul style="list-style-type: none"> • Inspecting the cable harness on page 138
Inspection	Information labels	Every: <ul style="list-style-type: none"> • 12 months 	<ul style="list-style-type: none"> • Inspecting the information labels on page 142
Inspection	Dampers	Every: <ul style="list-style-type: none"> • 12 months 	Inspecting the damper on axes 2-5 on page 149

Continues on next page

3 Maintenance

3.2.2 Maintenance schedule

Continued

Maintenance activity	Equipment	Interval	Detailed in section
Inspection	Mechanical stops	Every: <ul style="list-style-type: none"> 12 months 	<ul style="list-style-type: none"> Inspecting the axis-1 mechanical stop pin on page 144 Inspecting the additional mechanical stops on page 146
Changing	Oil in axis-1 gear-box:	Every: <ul style="list-style-type: none"> 12,000 hours 	Changing oil, axis-1 gear-box on page 155
Changing	Oil in axis-1 gear-box: Kyodo Yushi TMO 150	First change when DTC ⁱⁱⁱ reads: 6,000 hours Second change when DTC ⁱⁱⁱ reads: 24,000 hours Following changes: Every 24,000 hours	Do not mix with other oils! <ul style="list-style-type: none"> Changing oil, axis-1 gearbox on page 155
Changing	Oil in axis-2 gear-box: Optigear Synthetic RO	Every: <ul style="list-style-type: none"> 12,000 hours 	<ul style="list-style-type: none"> Changing oil, axis-2 gearbox on page 158
Changing	Oil in axis-2 gear-box: Kyodo Yushi TMO 150	First change when DTC ⁱⁱⁱ reads: 6,000 hours Second change when DTC ⁱⁱⁱ reads: 24,000 hours Following changes: Every 24,000 hours	Do not mix with other oils! <ul style="list-style-type: none"> Changing oil, axis-2 gearbox on page 158
Changing	Oil in axis-3 gear-box: Optigear Synthetic RO	Every: <ul style="list-style-type: none"> 12,000 hours 	<ul style="list-style-type: none"> Changing oil, axis-3 gearbox on page 161
Changing	Oil in axis-3 gear-box: Kyodo Yushi TMO 150	First change when DTC ⁱⁱⁱ reads: 6,000 hours Second change when DTC ⁱⁱⁱ reads: 24,000 hours Following changes: Every 24,000 hours	Do not mix with other oils! <ul style="list-style-type: none"> Changing oil, axis-3 gearbox on page 161
Changing	Oil in axis-4 gear-box	Every: <ul style="list-style-type: none"> 24,000 hours 	<ul style="list-style-type: none"> Changing oil, axis-4 gearbox on page 164
Changing	Oil in axis-5 gear-box	Every: <ul style="list-style-type: none"> 24,000 hours 	<ul style="list-style-type: none"> Changing oil, axis-5 gearbox on page 167
Changing	Oil in axis-6 gear-box	Every: <ul style="list-style-type: none"> 12,000 hours 	<ul style="list-style-type: none"> Changing oil, axis-6 gearbox on page 170

Continues on next page

Maintenance activity	Equipment	Interval	Detailed in section
Changing	Oil in axis-6 gearbox: Kyodo Yushi TMO 150	First change when DTC ⁱⁱⁱ reads: 6,000 hours Second change when DTC ⁱⁱⁱ reads: 24,000 hours Following changes: Every 24,000 hours	Do not mix with other oils! • Changing oil, axis-6 gearbox on page 170
Overhaul	Robot	Every: 40,000 hours	• Expected component life on page 114
Replacement	Battery pack, measurement system of type RMU101 or RMU102 (3-pole battery contact)	36 months or battery low alert ^{iv}	• Replacing the SMB battery on page 173
Replacement	Battery pack, measurement system with 2-pole battery contact, e.g. DSQC633A	Battery low alert ^v	• Replacing the SMB battery on page 173
Lubrication	Balancing device bearings	Every: 12,000 hours ^{vi}	

- ⁱ Only valid for robots that are equipped with Type B motors.
Type B motors include evacuation on the motor flange to indicate failure of primary sealing between the gearbox and the motor. Robots with protection type Foundry Plus have a sight glass installed in the evacuation holes.
See [Type A vs type B motors on page 395](#).
- ⁱⁱ Replace when damage or cracks is detected or life limit is approaching that specified in section [Expected component life on page 114](#).
- ⁱⁱⁱ DTC = Duty Time Counter. Shows the operational time of the robot.
- ^{iv} The battery low alert (38213 **Battery charge low**) is displayed when the battery needs to be replaced. The recommendation to avoid an unsynchronized robot is to keep the power to the controller turned on until the battery is to be replaced.
See the replacement instruction for more details.
- ^v The battery low alert (38213 **Battery charge low**) is displayed when remaining backup capacity (robot powered off) is less than 2 months. The typical lifetime of a new battery is 36 months if the robot is powered off 2 days/week or 18 months if the robot is powered off 16 h/day. The lifetime can be extended with a battery shutdown service routine. See *Operating manual - IRC5 with FlexPendant* or *Operating manual - OmniCore* for instructions.
- ^{vi} Always lubricate the front eye bearing after refitting the shaft of the balancing device.

Activities and intervals, optional equipment

The following table specifies the required maintenance activities and intervals for common optional equipment. The maintenance of other external equipment for the robot is detailed in separate documents.

Maintenance activity	Equipment	Interval	Note	Detailed in section
Inspection	Signal lamp	Every: 12 months		Inspecting, signal lamp on page 151
Inspection	Mechanical stop axes 1-2-3	Every: 12 months		Inspecting the additional mechanical stops on page 146

3 Maintenance

3.2.3 Expected component life

3.2.3 Expected component life

General

The expected life of a specific component of the robot can vary greatly depending on how hard it is run.

Expected component life - protection type Standard

Component	Expected life	Note
Cable harness Normal usage ⁱ	40,000 hours ⁱⁱ	Not including: <ul style="list-style-type: none">• Possible SpotPack harnesses• Optional upper arm harnesses
Cable harness Extreme usage ⁱⁱⁱ	20,000 hours ⁱⁱ	Not including: <ul style="list-style-type: none">• Possible SpotPack harnesses• Optional upper arm harnesses
Balancing device	40,000 hours ^{iv}	
Gearboxes ^v	40,000 hours	

ⁱ Examples of "normal usage" in regard to movement: most material handling applications and limited use of bending backwards mode of axis 3.

ⁱⁱ Severe chemical or thermal environments, or similar environments, can result in shortened life expectancy.

ⁱⁱⁱ Examples of "extreme usage" in regard to movement: press tending, very severe palletizing applications, major use of axis 1 movement and major use of bending backwards of axis 3.

^{iv} The given life for the balancing device is based on a test cycle of 4,000,000 cycles that starts from the initial position and goes to maximum extension, and back. Deviations from this cycle will result in differences in expected life!

^v Depending on application, the lifetime can vary. The Service Information System (SIS) that is integrated in the robot software can be used as guidance when planning gearbox service for the individual robot. This applies to gearboxes on axes 1, 2, 3 and 6. The lifetime of gearbox axes 4 and 5 is not calculated by SIS (See the *Operating manual - Service Information System*). In some applications, such as Foundry or Washing, the robot can be exposed to chemicals, high temperature or humidity, which can have an effect on the lifetime of the gearboxes. Contact the local **ABB Robotics Service team** for more information.

The SIS for an IRC5 system is described in the *Operating manual - Service Information System*.

3.3 Inspection activities

3.3.1 Inspecting the motor seal

Purpose of evacuation holes

This section is only valid for robots that are equipped with Type B motors.

The motors include evacuation on the motor flange to indicate failure of primary sealing between the gearbox and the motor.

More information is found in [Type A vs type B motors on page 395](#).

Location of evacuation hole on motor

The evacuation hole is located on each motor flange. The figure shows axis-1 motor as an example.

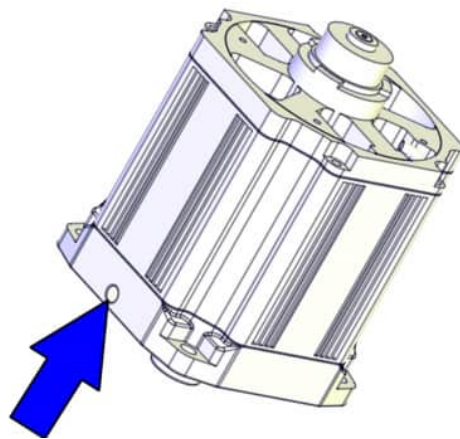

xx1500001057

Plug in the evacuation hole

New motors have a transparent plug/sight glass installed in the evacuation hole. Remove the plug or drill a drainage hole with diameter 3 mm, if an open evacuation hole is required instead.



xx2200002188



Continues on next page

3 Maintenance

3.3.1 Inspecting the motor seal

Continued

Inspecting the evacuation hole

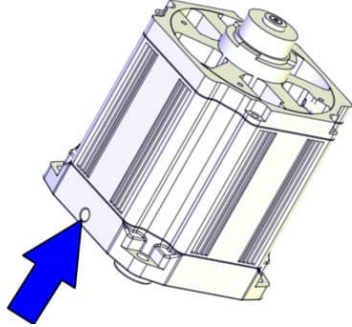
	Action	Note
1	 <p>DANGER</p> <p>Turn off all:</p> <ul style="list-style-type: none"> • electric power supply • hydraulic pressure supply • air pressure supply <p>to the robot, before entering the robot working area.</p>	
2	 <p>WARNING</p> <p>Handling gearbox oil involves several safety risks, see Gearbox lubricants (oil or grease) on page 36.</p>	
3	<p>Do a leakage check of the sight glass/evacuation hole of each motor.</p> <p>If any oil is available on the sight glass or if any oil has been spilled out from the evacuation hole, replacement of the motor is recommended.</p> <p> Note</p> <p>If oil is present in the evacuation it is an indication that the primary seal of the motor is leaking. A secondary seal after the evacuation is keeping the oil out from the motor, but it is still recommended to replace the motor at a suitable timing if oil is present in the evacuation.</p>	 <p>xx1500001057</p> <p>Replacing of motors is described in the repair chapter Motors on page 294.</p>

3.3.2 Inspecting the oil level in axis-1 gearbox

Location of gearbox

The axis-1 gearbox is located between the frame and base. See oil plugs in the following figure.

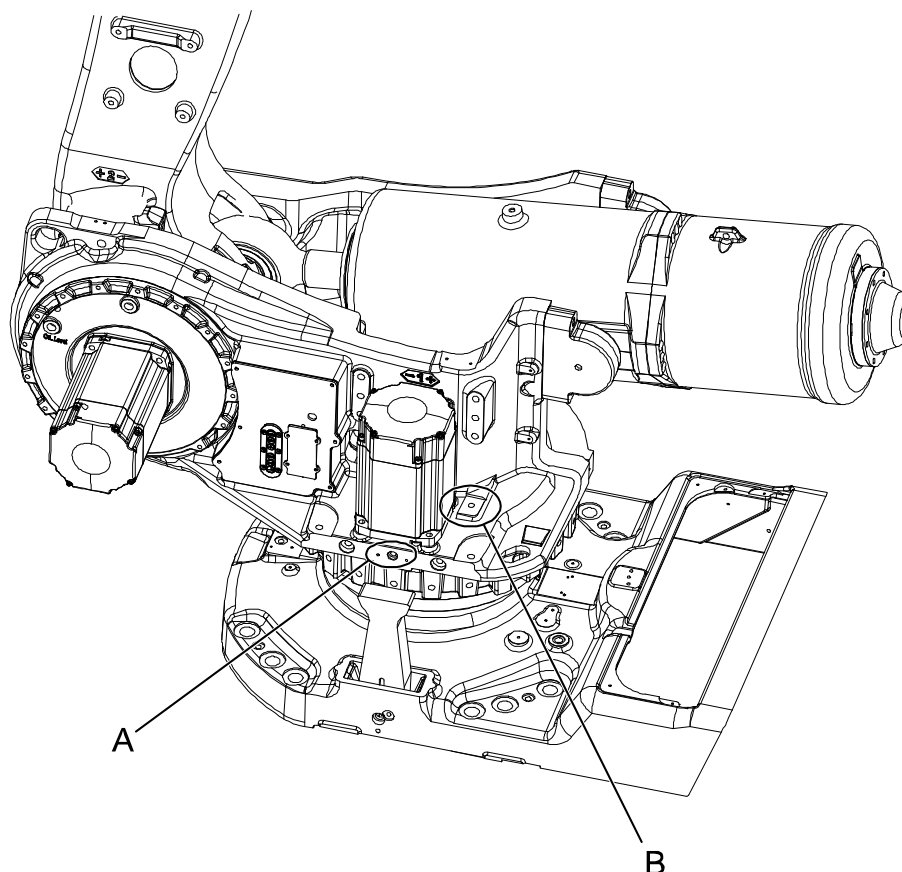

xx0300000583

A	Oil plug, inspection
B	Oil plug, filling

Required equipment

Equipment	Art. no.	Note
Lubricating oil	See <i>Type and amount of oil in gearboxes on page 153.</i>	 Note Do not mix with other oils!
Standard toolkit	-	Content is defined in section <i>Standard tools on page 406.</i>
Other tools and procedures may be required. See references to these procedures in the step-by-step instructions below.		These procedures include references to the tools required.

Continues on next page





3 Maintenance

3.3.2 Inspecting the oil level in axis-1 gearbox

Continued

Inspecting the oil level in axis-1 gearbox

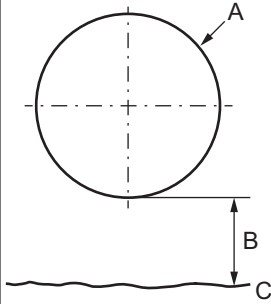
Use this procedure to inspect the oil level in the axis-1 gearbox.

	Action	Note
1	 WARNING Handling gearbox oil involves several safety risks, see Gearbox lubricants (oil or grease) on page 36 .	
2	 DANGER Turn off all: <ul style="list-style-type: none"> • electric power supply • hydraulic pressure supply • air pressure supply to the robot, before entering the safeguarded space.	
3	Make sure that the oil temperature is $+25^{\circ}\text{C} \pm 10^{\circ}\text{C}$.	This is a precaution to reduce the temperature dependency of the measurement.
4	Open the <i>oil plug, inspection</i> .	Shown in figure Location of gearbox on page 117 .
5	Measure the oil level. Required oil level: max. 10 mm below the oil plug hole.	 <p>xx1400002785</p> <p>A Oil plug hole B Required oil level C Gearbox oil</p>
6	Adjust the oil level, if required.	Where to find type of oil and total amount is detailed in Type of lubrication in gearboxes on page 153 . Further information about how to fill with oil is found in section Changing oil, axis-1 gearbox on page 155 .
7	Refit the oil plug.	Tightening torque: 24 Nm
8	 WARNING Do not mix oil types! If wrong oil is refilled, the gearbox must be rinsed as detailed in <i>Technical reference manual - Lubrication in gearboxes</i> .	

3.3.3 Inspecting the oil level in axis-2 gearbox

Location of gearbox

The axis-2 gearbox is located in the lower arm rotational center, underneath the motor attachment.

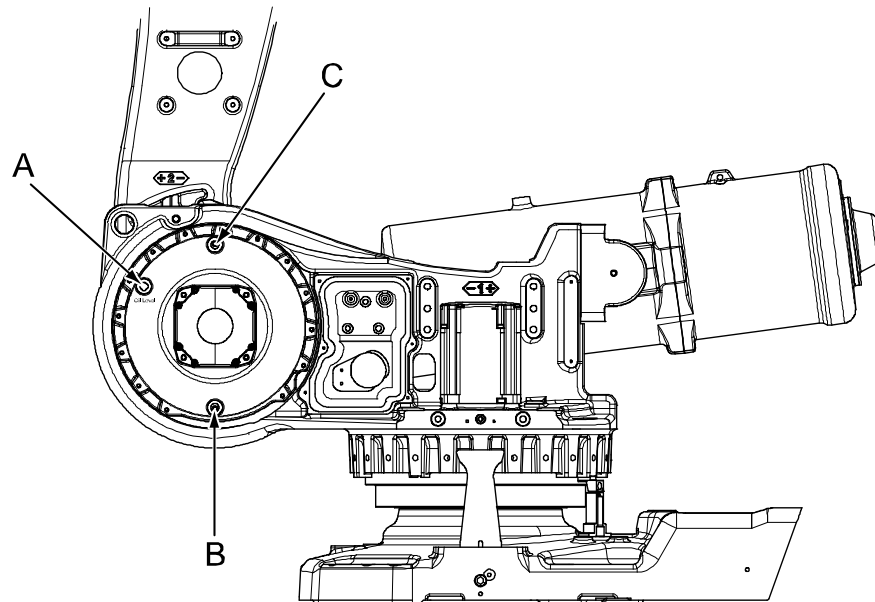

xx030000631

A	Oil plug, filling and inspection
B	Oil plug, draining
C	Vent hole, gearbox axis 2

Required equipment

Equipment, etc.,	Art. no.	Note
Lubricating oil	See <i>Type and amount of oil in gear-boxes on page 153.</i>	Note! Do not mix with other oils!
Standard toolkit	-	Content is defined in section <i>Standard tools on page 406.</i>
Other tools and procedures may be required. See references to these procedures in the step-by-step instructions below.		These procedures include references to the tools required.

Continues on next page





3 Maintenance

3.3.3 Inspecting the oil level in axis-2 gearbox

Continued

Inspecting the oil level in axis-2 gearbox

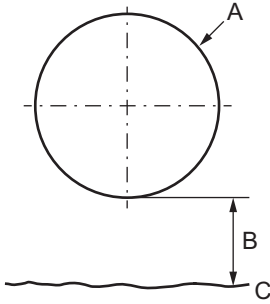
Use this procedure to inspect the oil level in the axis-2 gearbox.

	Action	Note
1	 WARNING Handling gearbox oil involves several safety risks, see Gearbox lubricants (oil or grease) on page 36 .	
2	 DANGER Turn off all: <ul style="list-style-type: none"> • electric power supply to the robot • hydraulic pressure supply to the robot • air pressure supply to the robot Before entering the robot working area.	
3	Make sure that the oil temperature is $+25^{\circ}\text{C} \pm 10^{\circ}\text{C}$.	This is a precaution to reduce the temperature dependency of the measurement.
4	Open the <i>oil plug, filling and inspection</i> .	Shown in the figure Location of gearbox on page 119 .
5	Measure the oil level. Required oil level: max. 5 mm below the inspection oil plug hole.	 <p>xx1400002785</p> <p>A Oil plug hole B Required oil level C Gearbox oil</p>
6	Adjust the oil level, if required.	Where to find type of oil and total amount is detailed in Type and amount of oil in gearboxes on page 153 . Filling of oil is detailed further in the section Filling, oil on page 159 .
7	Refit the oil plug.	Tightening torque: 24 Nm.
8	 WARNING Do not mix oil types! If wrong oil is refilled, the gearbox must be rinsed as detailed in <i>Technical reference manual - Lubrication in gearboxes</i> .	

3.3.4 Inspecting the oil level in axis-3 gearbox

Location of gearbox

The axis 3 gearbox is located in the upper arm rotational center as shown in the figure.

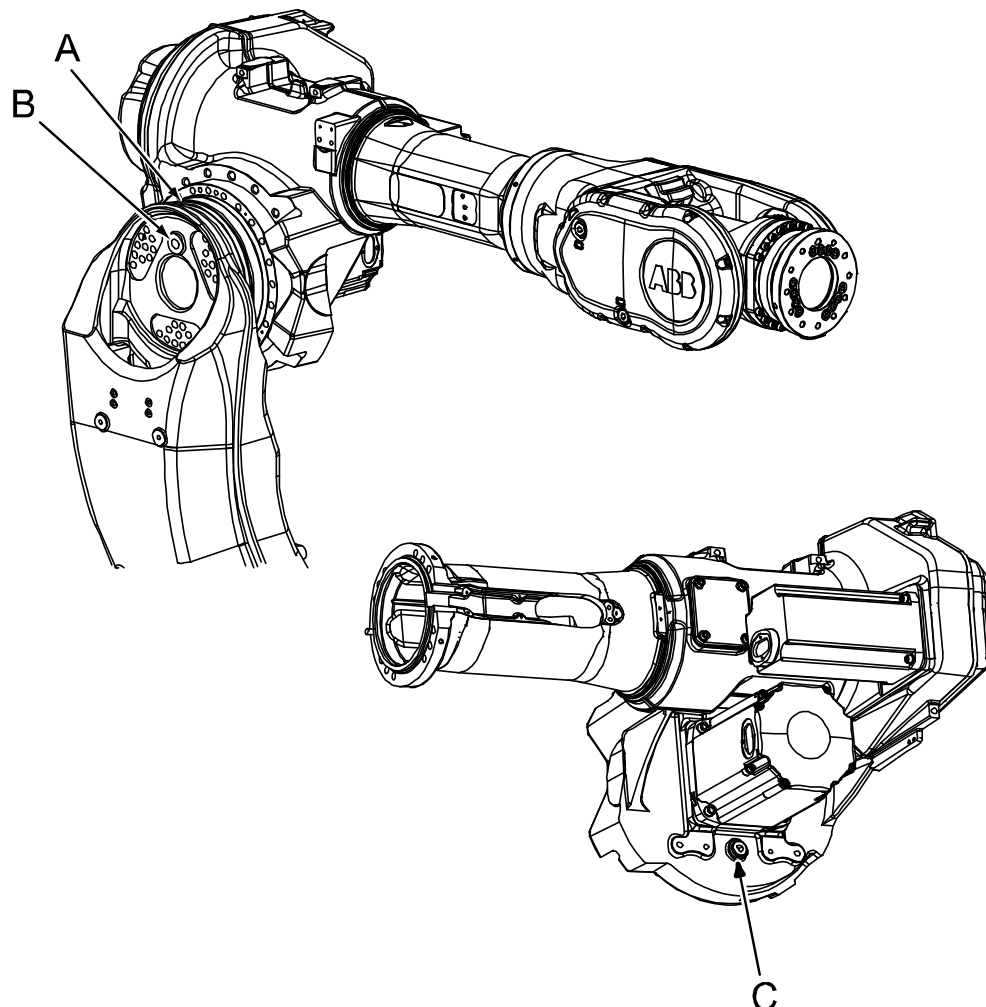

xx0200000230

A	Gearbox axis 3
B	Oil plug, filling and inspection
C	Oil plug, draining

Required equipment

Equipment, etc.	Art. no.	Note
Lubricating oil	See <i>Type and amount of oil in gearboxes on page 153.</i>	Note! Do not mix with other oils!
Standard toolkit	-	Content is defined in section <i>Standard tools on page 406.</i>

Continues on next page

3 Maintenance



3.3.4 Inspecting the oil level in axis-3 gearbox

Continued

Equipment, etc.	Art. no.	Note
Other tools and procedures may be required. See references to these procedures in the step-by-step instructions below.		These procedures include references to the tools required.

Inspecting the oil level in axis-3 gearbox

Use this procedure to inspect the oil level in the axis-3 gearbox.

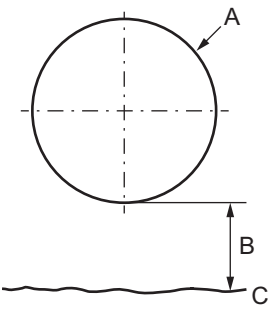
	Action	Note
1	 WARNING Handling gearbox oil involves several safety risks, see Gearbox lubricants (oil or grease) on page 36 .	
2	Move the robot to a position according to the illustration in Location of gearbox on page 121 .	Detailed in the section Synchronization marks and synchronization position for axes on page 364 .
3	 DANGER Turn off all: <ul style="list-style-type: none"> • electric power supply to the robot • hydraulic pressure supply to the robot • air pressure supply to the robot Before entering the robot working area.	
4	Make sure that the oil temperature is $+25^{\circ}\text{C} \pm 10^{\circ}\text{C}$.	This is a precaution to reduce the temperature dependency of the measurement.
5	Open the <i>oil plug, filling and inspection</i> .	Shown in the figure Location of gearbox on page 121 .
6	Measure the oil level. Required oil level: max. 5 mm below the filling oil plug hole.	 <p>xx1400002785</p> <p>A Oil plug hole B Required oil level C Gearbox oil</p>
7	Adjust the oil level, if required.	Where to find type of oil and total amount is detailed in Type and amount of oil in gearboxes on page 153 . Further information about how to fill the oil may be found in the section Filling, oil on page 163 .

Continues on next page

	Action	Note
8	Refit the oil plug.	Tightening torque:24 Nm
9	 WARNING Do not mix oil types! If wrong oil is refilled, the gearbox must be rinsed as detailed in <i>Technical reference manual - Lubrication in gearboxes</i> .	

3 Maintenance

3.3.5 Inspecting the oil level in axis-4 gearbox

3.3.5 Inspecting the oil level in axis-4 gearbox

Location of gearbox

The axis-4 gearbox is located in the rear part of the upper arm as shown in the figure.

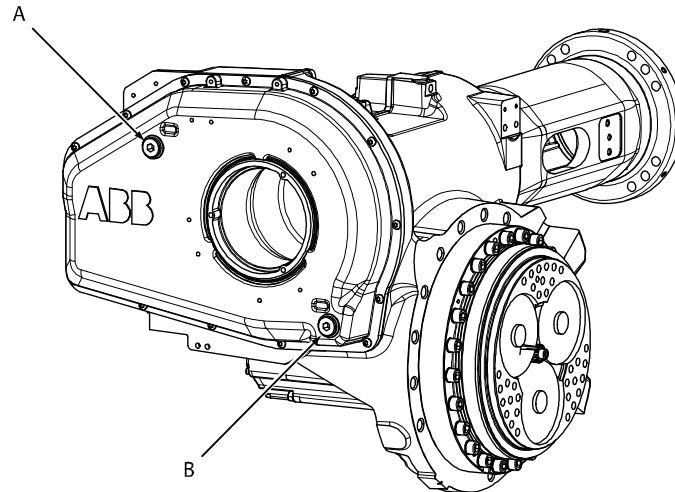

xx020000231

A	Oil plug, filling and inspection
B	Oil plug, draining

Required equipment



Equipment, etc.	Art. no.	Note
Lubricating oil	See Type and amount of oil in gearboxes on page 153 .	
Standard toolkit	-	Content is defined in section Standard tools on page 406 .
Other tools and procedures may be required. See references to these procedures in the step-by-step instructions below.		These procedures include references to the tools required.

Inspecting the oil level in axis-4 gearbox

Use this procedure to inspect the oil level in the axis-4 gearbox.

	Action	Note
1	 WARNING Handling gearbox oil involves several safety risks, see Gearbox lubricants (oil or grease) on page 36 .	

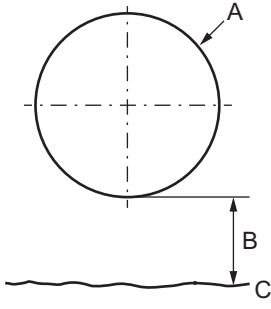
Continues on next page

	Action	Note
2	Move the robot to the calibration position.	This is detailed in section Synchronization marks and synchronization position for axes on page 364 .
3	 DANGER Turn off all: <ul style="list-style-type: none"> • electric power supply to the robot • hydraulic pressure supply to the robot • air pressure supply to the robot Before entering the robot working area.	
4	Make sure that the oil temperature is $+25^{\circ}\text{C} \pm 10^{\circ}\text{C}$.	This is a precaution to reduce the temperature dependency of the measurement.
5	Open the <i>oil plug, filling and inspection</i> .	Shown in the figure Location of gearbox on page 124 .
6	Measure the oil level. Required oil level: 0-10 mm	 <p>xx1400002785</p> <p>A Oil plug hole B Required oil level C Gearbox oil</p>
7	Adjust the oil level, if required.	Where to find type of oil and total amount is detailed in Type and amount of oil in gearboxes on page 153 . Further information about how to fill the oil may be found in the section Filling, oil on page 165 .
8	Refit the oil plug.	Tightening torque:24 Nm
9	 WARNING Do not mix oil types! If wrong oil is refilled, the gearbox must be rinsed as detailed in <i>Technical reference manual - Lubrication in gearboxes</i> .	

3 Maintenance

3.3.6 Inspecting the oil level in axis-5 gearbox

3.3.6 Inspecting the oil level in axis-5 gearbox

Location of gearbox

The axis-5 gearbox is located in the wrist unit as shown in the figure.

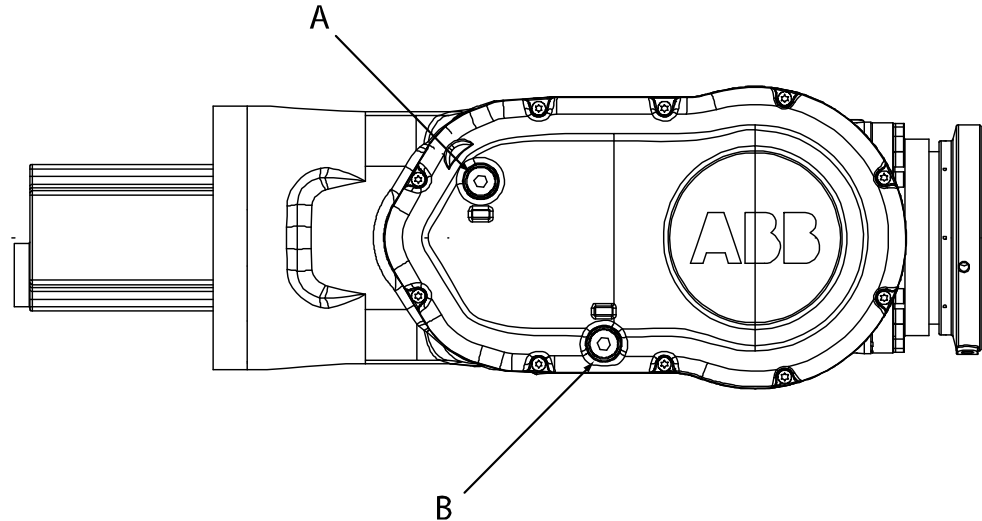

xx0200000232

-	The figure above shows the wrist unit of IRB 6600 and IRB 6650
A	Oil plug, filling and inspection
B	Oil plug, draining

Required equipment



Equipment etc.	Art. no.	Note
Lubricating oil	See <i>Type and amount of oil in gearboxes on page 153.</i>	
Standard toolkit	-	Content is defined in section <i>Standard tools on page 406.</i>
Other tools and procedures may be required. See references to these procedures in the step-by-step instructions below.		These procedures include references to the tools required.

Inspecting the oil level in axis-5 gearbox

Use this procedure to inspect the oil level in the axis-5 gearbox.

	Action	Note
1	 WARNING Handling gearbox oil involves several safety risks, see <i>Gearbox lubricants (oil or grease) on page 36.</i>	
2	Move the robot upper arm to a horizontal position.	

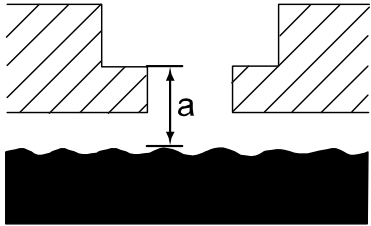
Continues on next page

	Action	Note
3	Turn the wrist unit in a way that both oil plugs are facing upwards.	
4	 DANGER Turn off all: <ul style="list-style-type: none"> • electric power supply to the robot • hydraulic pressure supply to the robot • air pressure supply to the robot Before entering the robot working area.	
5	Make sure that the oil temperature is $+25^{\circ}\text{C} \pm 10^{\circ}\text{C}$.	This is a precaution to reduce the temperature dependency of the measurement.
6	Open the <i>oil plug, filling and inspection</i> .	Shown in the figure Location of gearbox on page 126 .
7	Measure the oil level. Required oil level to the upper edge of the filling and inspection oil plug hole (a): 30 mm	 <small>xx0500002222</small>
8	Adjust the oil level, if required.	Where to find type of oil and total amount is detailed in Type and amount of oil in gearboxes on page 153 . Further information about how to fill the oil may be found in the section Filling, oil, axis 5 on page 168 .
9	Refit the oil plug.	Tightening torque: 24 Nm
10	 WARNING Do not mix oil types! If wrong oil is refilled, the gearbox must be rinsed as detailed in <i>Technical reference manual - Lubrication in gearboxes</i> .	

3 Maintenance

3.3.7 Inspecting the oil level in axis-6 gearbox

3.3.7 Inspecting the oil level in axis-6 gearbox

Location of gearbox

The axis-6 gearbox is located in the wrist unit as shown in this figure.

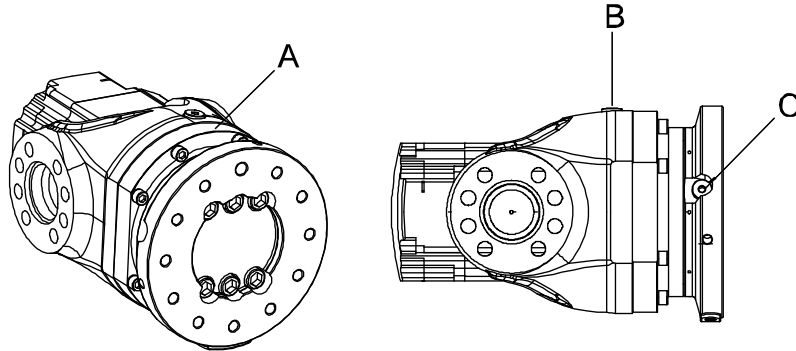

xx0600002964

	Type 1
A	Axis-6 gearbox
B	Oil plug, filling and inspection
C	Oil plug, draining

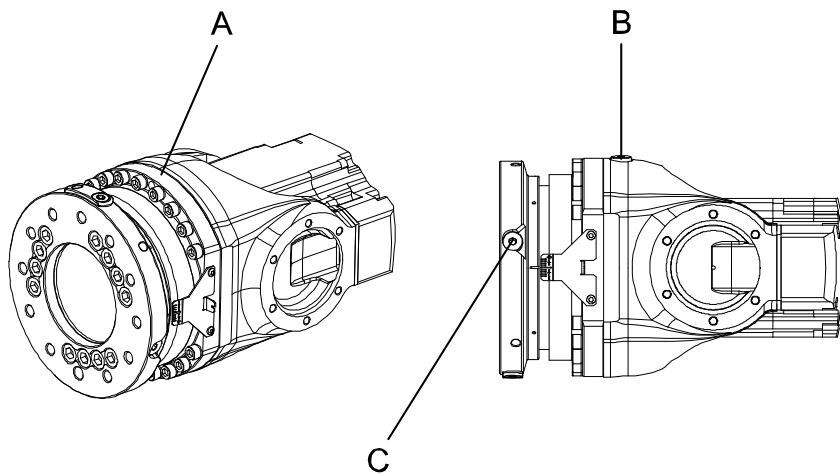

xx0400001092

	Type 2
A	Axis-6 gearbox
B	Oil plug, filling and inspection
C	Oil plug, draining

Inspection depending on type of wrist

To inspect oil level for wrist type 1, see [Inspecting the oil level in axis-6 gearbox, wrist type 1 on page 129](#).

To inspect oil level for wrist type 2, see [Inspecting the oil level in axis-6 gearbox, wrist type 2 on page 130](#).



Continues on next page

Required equipment

Equipment	Art. no.	Note
Lubricating oil	See <i>Type and amount of oil in gearboxes on page 153.</i>	
Standard toolkit	-	Content is defined in section <i>Standard tools on page 406.</i>
Other tools and procedures may be required. See references to these procedures in the step-by-step instructions below.		These procedures include references to the tools required.

Inspecting the oil level in axis-6 gearbox, wrist type 1

Use this procedure to inspect the oil level in the axis-6 gearbox, for wrist type 1.

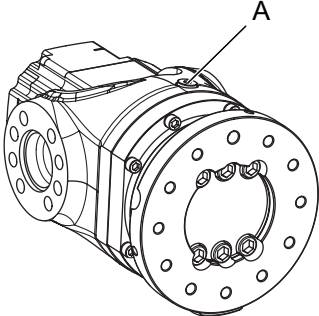



	Action	Note
1	 WARNING Handling gearbox oil involves several safety risks, see <i>Gearbox lubricants (oil or grease) on page 36.</i>	
2	Move axes 3 and 5 to a horizontal position, and make sure that the <i>oil plug, filling and inspection</i> is facing upwards.	
3	 DANGER Turn off all: <ul style="list-style-type: none"> • electric power supply to the robot • hydraulic pressure supply to the robot • air pressure supply to the robot Before entering the robot working area.	
4	Make sure that the oil temperature is $+25^{\circ}\text{C} \pm 10^{\circ}\text{C}$.	This is a precaution to reduce the temperature dependency of the measurement.
5	Open the <i>oil plug, filling and inspection</i> .	 xx130000244
6	Turn axis 6 so that the <i>oil plug, draining</i> faces upwards.	

Continues on next page

3 Maintenance

3.3.7 Inspecting the oil level in axis-6 gearbox

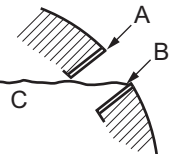
Continued



	Action	Note
7	Open the <i>oil plug, draining</i> .	<p>This is a precaution to avoid vacuum effects by allowing air to enter at the top of the gearbox.</p> <p> Note</p> <p>If equipment that covers the <i>oil plug, draining</i> is fitted on the robot so that the oil plug cannot be opened, then this step can be skipped.</p>
8	Slowly turn axis 4, while adjusting axis 6 so that the oil plug, draining always faces upwards. Turn axis 4 until the axis-4 angle reads -45° to -55° .	
9	<p>Inspect the oil level in the hole for the <i>oil plug, filling and inspection</i>.</p> <p>The oil should reach all the way up to the external edge of the thread for the <i>oil plug, filling and inspection</i>.</p> <p> Note</p> <p>If the <i>oil plug, draining</i> is not opened, then use a clean, narrow object, for example an oil stick or a cable tie, to gently poke the oil surface. This will avoid surface tension from stopping air to enter into the gearbox.</p>	 <p>xx1400002786</p> <p>A Oil plug hole B Required oil level C Gearbox oil</p>
10	Adjust the oil level, if required.	<p>Where to find type of oil and total amount is detailed in Type and amount of oil in gearboxes on page 153.</p> <p>Further information about how to fill the oil may be found in the section Filling, oil, axis 6 on page 171.</p>
11	Refit the oil plugs.	Tightening torque: 24 Nm.
12	<p> WARNING</p> <p>Do not mix oil types! If wrong oil is refilled, the gearbox must be rinsed as detailed in <i>Technical reference manual - Lubrication in gearboxes</i>.</p>	

Inspecting the oil level in axis-6 gearbox, wrist type 2

Use this procedure to inspect the oil level in the axis-6 gearbox, for wrist type 2.

	Action	Note
1	<p> WARNING</p> <p>Handling gearbox oil involves several safety risks, see Gearbox lubricants (oil or grease) on page 36.</p>	

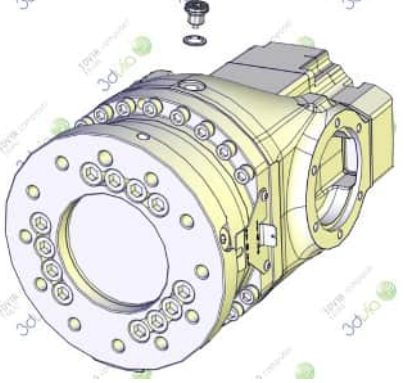
Continues on next page

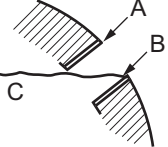
	Action	Note
2	Move axes 3 and 5 to a horizontal position, and make sure that the <i>oil plug, filling and inspection</i> is facing upwards.	
3	 DANGER Turn off all: <ul style="list-style-type: none"> • electric power supply to the robot • hydraulic pressure supply to the robot • air pressure supply to the robot Before entering the robot working area.	
4	Make sure that the oil temperature is $+25^{\circ}\text{C} \pm 10^{\circ}\text{C}$.	This is a precaution to reduce the temperature dependency of the measurement.
5	Remove the <i>oil plug, filling and inspection</i> .	 <p>xx1300002447</p>
6	Slowly turn axis 4 until the axis-4 angle reads $+72.5^{\circ}$ to $+77.5^{\circ}$.	
7	Inspect the oil level in the hole for the <i>oil plug, filling and inspection</i> . The oil should reach all the way up to the external edge of the thread for the <i>oil plug, filling and inspection</i> .  Note If needed, use a clean, narrow object, for example an oil stick or a cable tie, to gently poke the oil surface. This will avoid surface tension from stopping air to enter into the gearbox.	 <p>xx1400002786</p> <ul style="list-style-type: none"> A Oil plug hole B Required oil level C Gearbox oil
8	Adjust the oil level, if required.	Where to find type of oil and total amount is detailed in Type and amount of oil in gearboxes on page 153 . Further information about how to fill the oil may be found in the section Filling, oil, axis 6 on page 171 .
9	Refit the oil plug.	Tightening torque: 24 Nm.

Continues on next page

3 Maintenance

3.3.7 Inspecting the oil level in axis-6 gearbox

Continued

	Action	Note
10	 WARNING Do not mix oil types! If wrong oil is refilled, the gearbox must be rinsed as detailed in <i>Technical reference manual - Lubrication in gearboxes</i> .	

3.3.8 Inspecting the balancing device

General

Several points are to be checked on the balancing device during the inspection. This section describes how to perform the inspection regarding:

- dissonance
- damage
- leakage
- contamination / lack of free space.

Inspection points, balancing device

The balancing device is located at the top rear of the frame as shown in the figure. The figure also shows the inspection points, further described in the instructions.

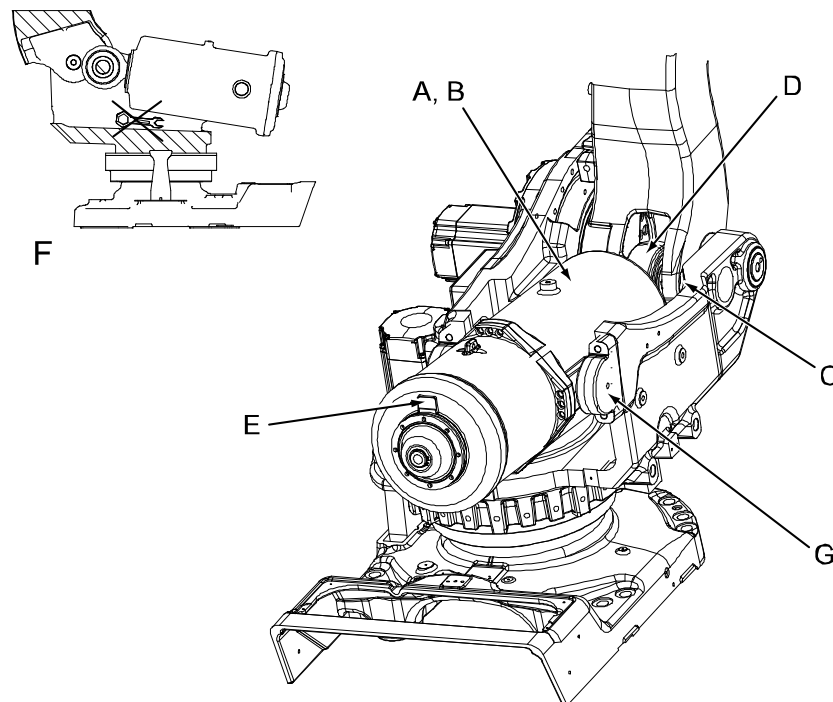

xx0400001025

A	Balancing device
B	Piston rod (inside)
C	Shaft, including securing screw
D	Ear, bearing and o-rings
E	Label with article number
F	Inspect the surroundings
G	Bearing, balancing device attachments

Continues on next page

3 Maintenance

3.3.8 Inspecting the balancing device

Continued

Required equipment

Equipment, etc.	Spare part no.	Art. no.	Note
Maintenance kit, complete	-		Includes: <ul style="list-style-type: none"> complete kit including the kit with bearings and seals instructions for maintenance.
Maintenance kit, bearings and seals	-		Includes: <ul style="list-style-type: none"> kit with bearings, o-rings and seals only instructions for maintenance.
Securing screw			Securing screw in the shaft. M16 x 180 Locking liquid must be used when fitting the screw (Loctite 243)!
Toolkit for maintenance			See chapter <i>Reference information</i> .
Puller for separator		4552-2 (Bahco)	Used for removing the spherical roller bearings.
Separator		4551-C (Bahco)	Used for removing the spherical roller bearings.
Standard toolkit		3HAC15571-1	Content is defined in section Standard tools on page 406 .
Other tools and procedures may be required. See references to these procedures in the step-by-step instructions below.			These procedures include references to the tools required.

Check for dissonance

The check points are shown in the figure [Inspection points, balancing device on page 133](#).

	Check for dissonance from...	If dissonance is detected...
1	<ul style="list-style-type: none"> bearing at the link ear bearings at the balancing devices attachments. 	<p>... perform maintenance according to given instructions in Maintenance kit, bearings and seals. The replacement of the bearing at the ear is also detailed in section Replacement of spherical roller bearing, balancing device on page 279.</p> <p>Art. no. for the kit and the documentation are specified in section Required equipment on page 134.</p>
2	<ul style="list-style-type: none"> balancing device (a tapping sound, caused by the springs inside the cylinder). 	<p>...replace the balancing device or consult ABB Robotics. How to replace the device is detailed in section Replacing the balancing device on page 282. This section also specifies the spare part number!</p>

Continues on next page

	Check for dissonance from...	If dissonance is detected...
3	<ul style="list-style-type: none"> piston rod (squeaking may indicate worn plain bearings, internal contamination or insufficient lubrication). 	<p>If dissonance is detected, wipe clean the piston rod.</p> <p>If dissonance continues after the piston rod is cleaned, perform maintenance according to given instructions in <i>Maintenance kit, complete</i>.</p> <p>Art. no. for the kit and the documentation are specified in section Required equipment on page 134.</p>

Check for damage

Check for damage, such as scratches, general wear, uneven surfaces or incorrect positions.

The check points are shown in the figure [Inspection points, balancing device on page 133](#).

	Check for damage on...	If damage is detected...
1	<ul style="list-style-type: none"> the piston rod (part of the piston rod that is visible at the front of the balancing device). 	<p>... perform maintenance according to given instructions in <i>Maintenance kit, complete</i>.</p> <p>Art. no. for the kit and the documentation are specified in section Required equipment on page 134.</p>
2	<ul style="list-style-type: none"> the securing screw in the front ear shaft. <p>Also check the tightening torque (50 Nm).</p>	<p>...replace.</p> <p>Dimension is specified in section Required equipment on page 134.</p>

Check for leakage

The front ear of the balancing device is lubricated with grease. After filling, excessive grease may normally be forced out between the shaft and the sealing ring in the sealing spacer. This is normal behaviour and must not be confused with incorrect leaks from the ear.

Leaks at the o-rings and/or sealings, are not acceptable and must be attended to immediately in order to avoid any damage to the bearing!

Continues on next page

3 Maintenance

3.3.8 Inspecting the balancing device

Continued

Check the o-rings in the front ear of the balancing device for leaks, as shown and detailed below.

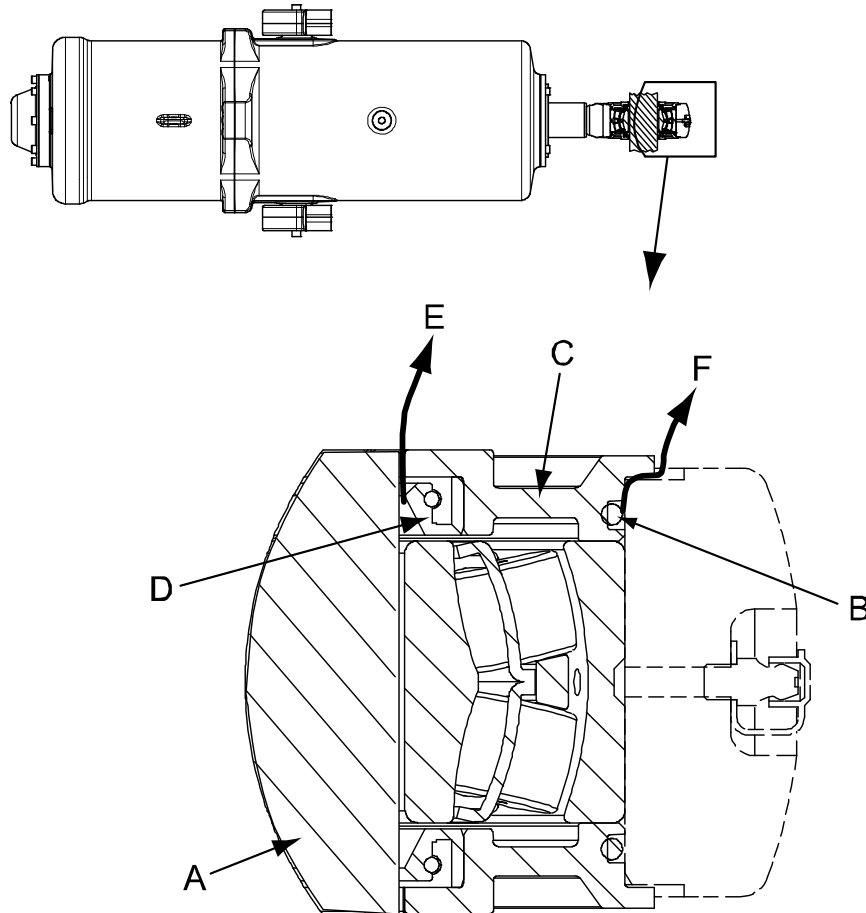

xx0400001026

A	Shaft
B	O-ring
C	Sealing spacer
D	Sealing ring in sealing spacer
E	Correct way out for excessive grease from inside the front ear
F	Incorrect leakage from the front ear

	Action	Note
1	Clean the area at the front ear from old grease.	
2	Run the robot for some minutes, in order to move the balancing device piston.	

Continues on next page

	Action	Note
3	Check the o-rings at the front ear for leakage. Replace the o-rings, if any leaks are detected. Excessive grease from between the shaft and the sealing ring is normal and is not considered as a leak!	<p>The o-rings are included in the <i>Maintenance kit, bearings and seals</i>, already assembled with sealing spacers and sealing rings.</p> <p>Art. no. for the kit is specified in Required equipment on page 134.</p> <p>The replacement of the complete bearing is also detailed in section Replacement of spherical roller bearing, balancing device on page 279.</p> <p>Incorrect leakage is shown in the previous figure.</p>

Check for contamination / lack of free space

	Action	
1	 <p>DANGER</p> <p>Turn off all:</p> <ul style="list-style-type: none"> • electric power supply • hydraulic pressure supply • air pressure supply <p>to the robot, before entering the safeguarded space.</p>	
2	<p>Check that there are no obstacles inside the frame, that could prevent the balancing device from moving freely. See the figure Inspection points, balancing device on page 133.</p> <p>Keep the areas around the balancing device clean and free from objects, such as service tools.</p>	

3 Maintenance

3.3.9 Inspecting the cable harness

3.3.9 Inspecting the cable harness

Location of cable harness, axes 1-4

The robot cable harness, axes 1-4, is located as shown in the figure below.

Note! The cable harness is also available without the division point R2.M5/6. Except for the connectors at the division point, the rest of the inspection points are the same for the harness that runs undivided from axis 1 to axis 6.

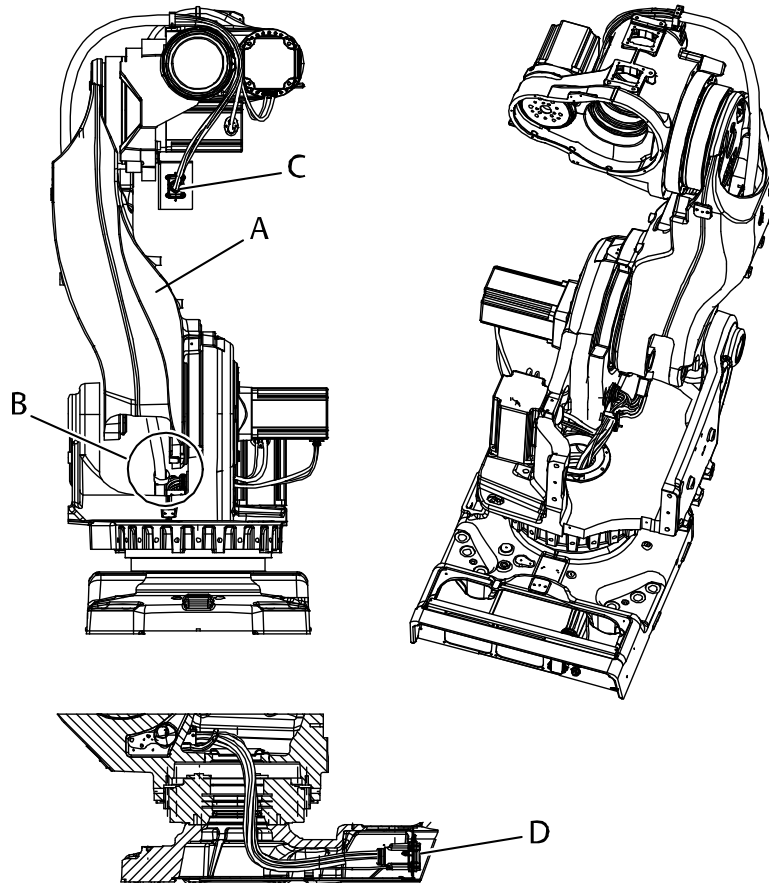

xx020000097

A	Lower arm
B	Cables attached with velcro straps and mounting plate
C	Connectors at cable harness division point, R2.M5/6
D	Connectors at base

Required equipment

Equipment, etc.	Art. no.	Note
Standard toolkit	-	Content is defined in section Standard tools on page 406 .

Continues on next page

Equipment, etc.	Art. no.	Note
Other tools and procedures may be required. See references to these procedures in the step-by-step instructions below.		These procedures include references to the tools required.
Circuit diagram		See chapter Circuit diagram on page 411 .

Inspection, cable harness 1-4

The procedure below details how to inspect the cable harness of axes 1-4.

	Action	Note
1	 DANGER Turn off all: <ul style="list-style-type: none"> • electric power supply to the robot • hydraulic pressure supply to the robot • air pressure supply to the robot Before entering the robot working area.	
2	Make an overall visual inspection of the cable harness, in order to detect wear and damage.	
3	Check the <i>connectors at the division point and at the base</i> .	Shown in the figure Location of cable harness, axes 1-4 on page 138 .
4	Check that <i>velcro straps and the mounting plate</i> are properly attached to the frame. Also check the cabling, leading into the lower arm. Make sure it is attached by the straps and not damaged.	Location is shown in the figure Location of cable harness, axes 1-4 on page 138 . A certain wear of the hose at the entrance to the lower arm is natural.
5	Replace the cable harness if wear, cracks or damage is detected.	Described in section Replacing cable harness, axes 1-6 on page 192 .

Continues on next page

3 Maintenance

3.3.9 Inspecting the cable harness

Continued

Location of cabling axes 5-6

The robot cable harness, axes 5-6, is located as shown in the figure below.

Note! The cable harness is also available without the division point R2.M5/6. Except for the connectors at the division point, the rest of the inspection points are the same for the harness that runs undivided from axis 1 to axis 6.

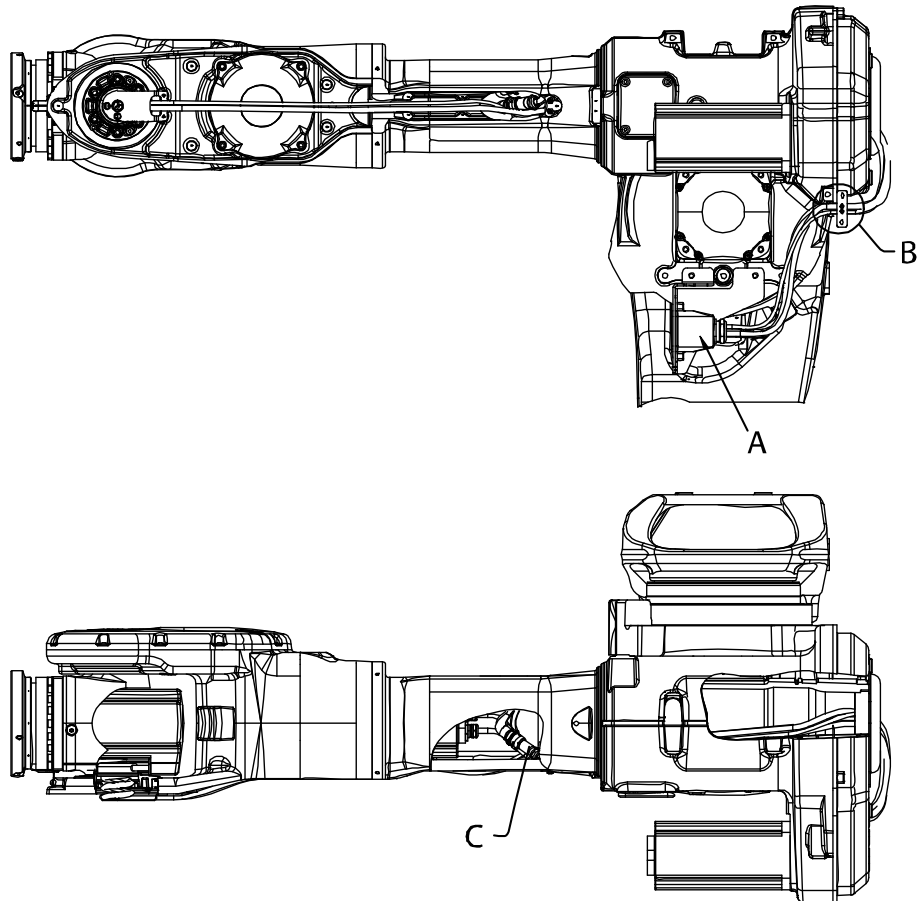

xx0200000234

A	Connectors at cable harness division point, R2.M5/6
B	Cable attachment, rear of upper arm
C	Cable attachment, upper arm tube

Inspection, cable harness, axes 5-6

The procedure below details how to inspect the cable harness of axes 5-6.

Action	Note
<p>1</p> <p> DANGER</p> <p>Turn off all:</p> <ul style="list-style-type: none"> • electric power supply to the robot • hydraulic pressure supply to the robot • air pressure supply to the robot <p>Before entering the robot working area.</p>	

Continues on next page

	Action	Note
2	Make an overall visual inspection of the cable harness, in order to detect wear and damage.	
3	Check the <i>attachments at the rear of the upper arm and in the upper arm tube</i> . Check the <i>connectors at the cable harness division</i> . Make sure the attachment plate is not bent or in any other way damaged.	Shown in the figure Location of cabling axes 5-6 on page 140 .
4	Replace the cable harness if wear, cracks or damage is detected.	Described in section Replacement of cable harness, axes 5-6 on page 218!

3 Maintenance

3.3.10 Inspecting the information labels

3.3.10 Inspecting the information labels

Location of labels

These figures show the location of the information labels to be inspected. The symbols are described in section [Safety symbols on manipulator labels on page 25](#).

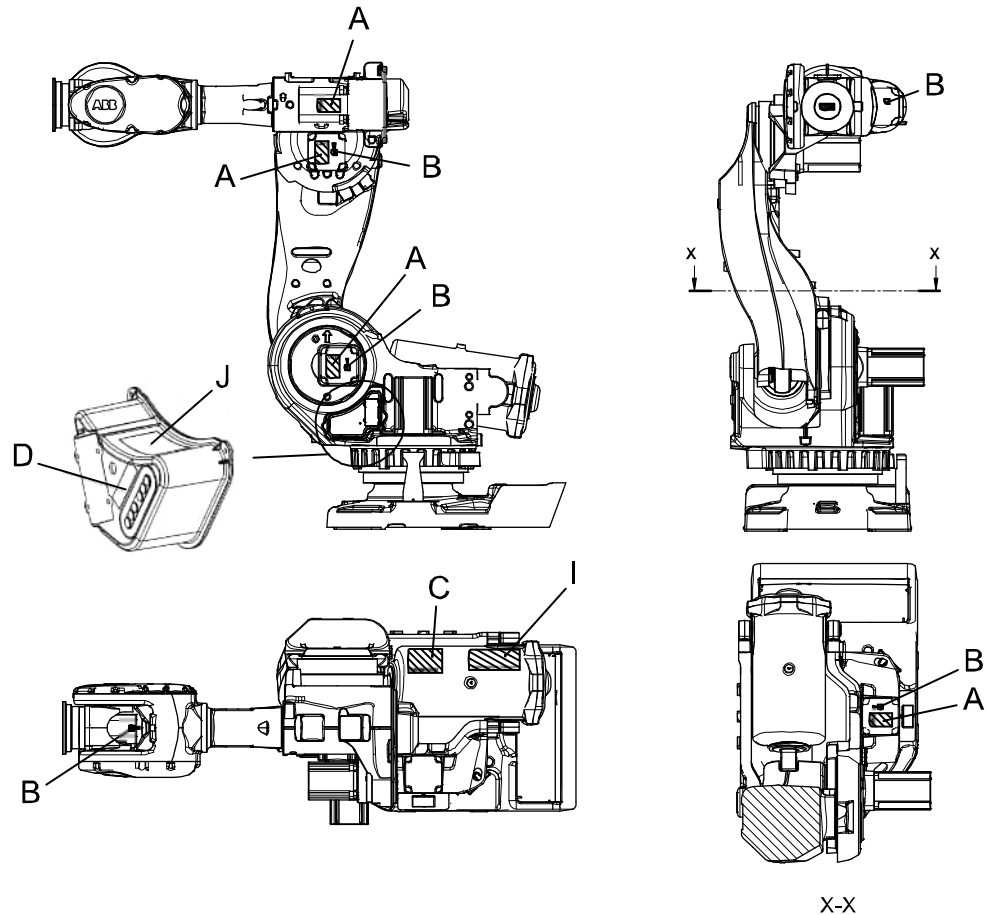

xx0200000236

A	Warning label concerning high temperature (4 pcs)
B	Warning label, symbol of a flash (located on motor cover) (5 pcs)
C	Instruction label
D	Warning label concerning brake release
I	Warning label, tools are not allowed around the balancing device during operation
J	Warning label concerning shutting off power
-	Information labels at gearboxes and at robot base, if gearboxes are filled with Kyodo Yushi TMO 150

Continues on next page

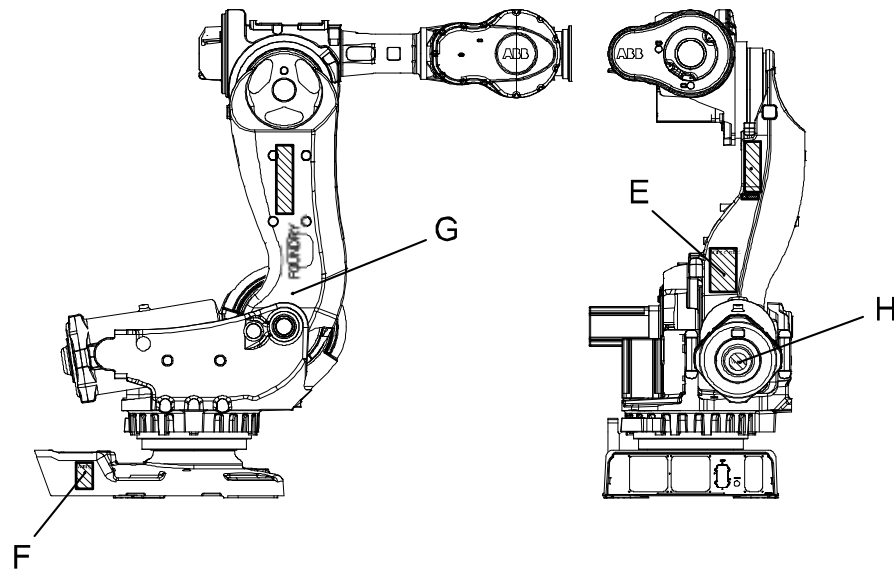

xx0400000786

E	Instruction label concerning lifting the robot
F	Warning label concerning risk of tipping
G	Foundry logotype
H	Warning label concerning stored energy

Required tools and equipment

Visual inspection, no tools are required.

Inspecting, labels

	Action	Note
1	 DANGER Turn off all: <ul style="list-style-type: none"> • electric power supply • hydraulic pressure supply • air pressure supply to the robot, before entering the safeguarded space.	
2	Inspect the labels, located as shown in the figures.	
3	Replace any missing or damaged labels.	Article numbers for the labels and plate set is specified in <i>Spare part lists on page 397</i> .

3 Maintenance

3.3.11 Inspecting the axis-1 mechanical stop pin

3.3.11 Inspecting the axis-1 mechanical stop pin



WARNING

Mechanical stop pin can not be fitted onto robot if the option 561-1 *Extended working range* is used for axis 1.

Location of mechanical stop pin

The axis-1 mechanical stop is located as shown in the figure.

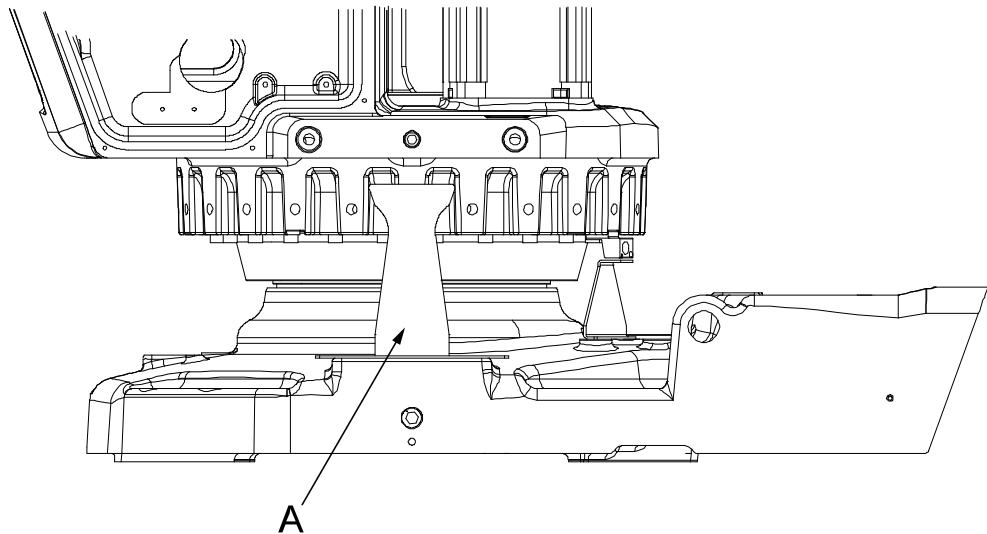

xx0200000151

A	Mechanical stop pin
---	---------------------

Required equipment

Visual inspection, no tools are required.

Inspecting, mechanical stop pin

Use this procedure to inspect the axis-1 mechanical stop pin.

	Action	Note
1	 DANGER Turn off all: <ul style="list-style-type: none">• electric power supply• hydraulic pressure supply• air pressure supply to the robot, before entering the safeguarded space.	

Continues on next page

	Action	Note
2	<p>Inspect the axis-1 mechanical stop pin. If the mechanical stop pin is bent or damaged, it must be replaced.</p> <p> Note</p> <p>The expected life of gearboxes can be reduced after collision with the mechanical stop.</p>	
3	<p>Make sure the mechanical stop pin can move in both directions.</p>	

3 Maintenance

3.3.12 Inspecting the additional mechanical stops

3.3.12 Inspecting the additional mechanical stops

Location of mechanical stops

The figure shows the location of the additional mechanical stops on axes 1, 2 and 3 (IRB 7600 shown).

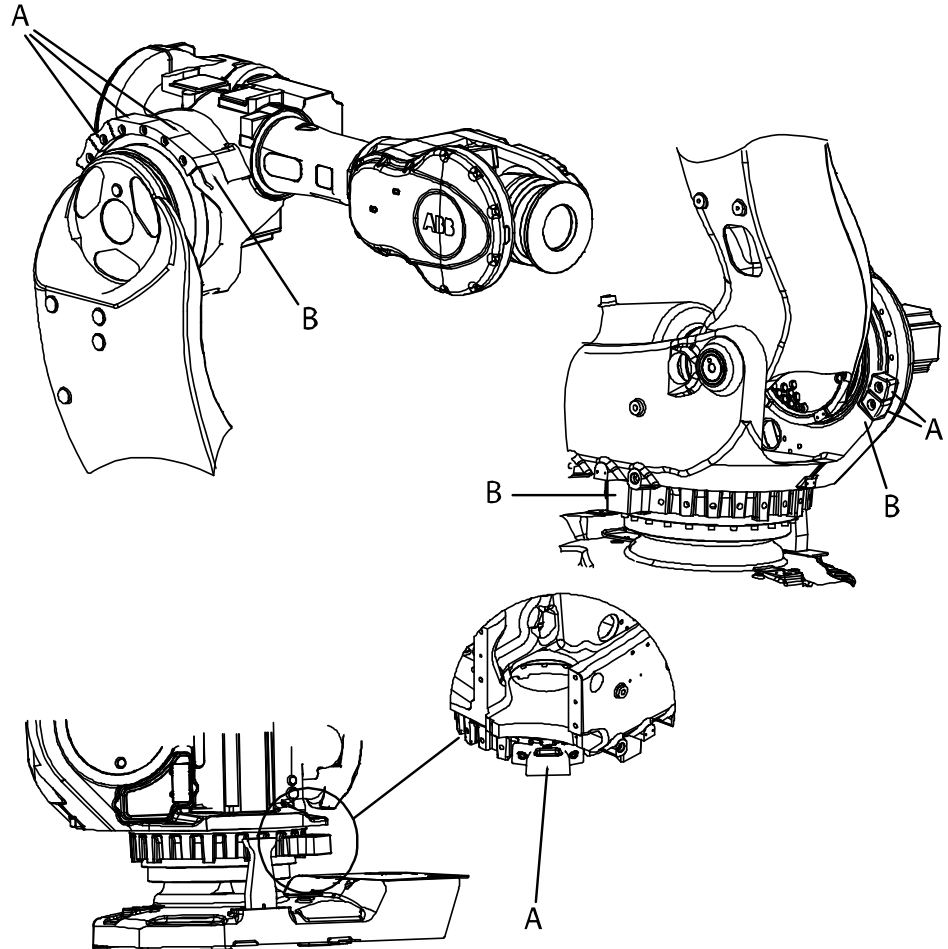

xx0200000150

A	Additional stop
B	Fixed stop

Continues on next page

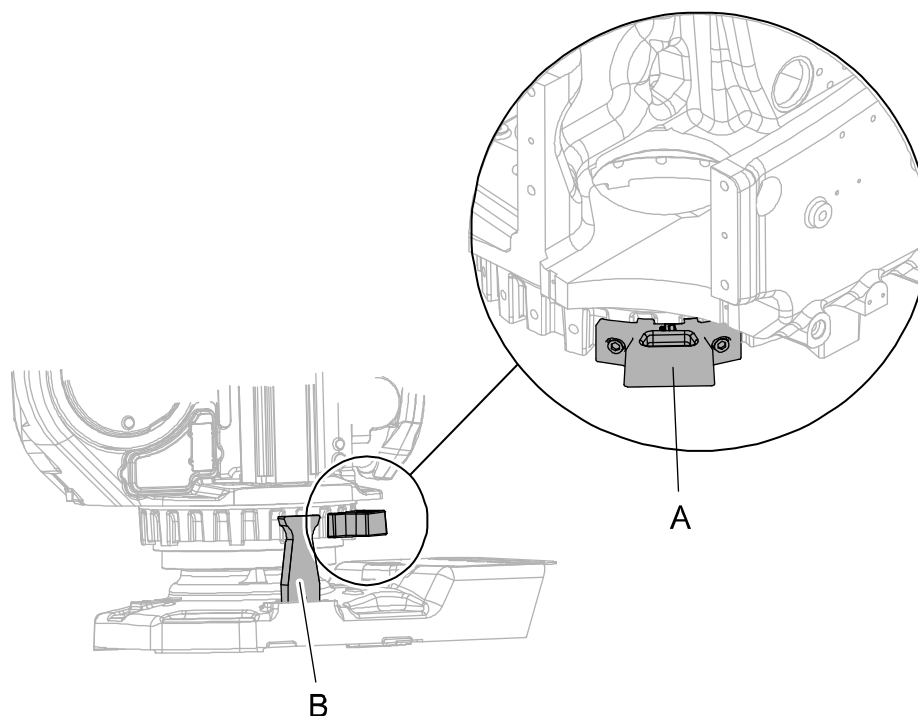

xx030000049

A	Additional mechanical stop
B	Stop pin

Required equipment

Equipment etc.	Article number	Note
Mechanical stop axis 1	3HAC11076-1	Limits the robot working range by 7.5°.
Mechanical stop axis 1	3HAC11076-2	Limits the robot working range by 15°.
Mechanical stop axis 2	3HAC13787-1	Includes: <ul style="list-style-type: none"> • Mechanical stop • Attachment screw and washer • Document for mechanical stop
Mechanical stop set axis 3	3HAC13128-1	Includes: <ul style="list-style-type: none"> • Mechanical stop • Attachment screw and washer • Document for mechanical stop
Standard toolkit	-	Content is defined in section Standard tools on page 406 .

Continues on next page

3 Maintenance

3.3.12 Inspecting the additional mechanical stops

Continued

Inspecting, mechanical stops

Use this procedure to inspect the additional mechanical stops.

	Action	Note
1	 DANGER Turn off all: <ul style="list-style-type: none">• electric power supply• hydraulic pressure supply• air pressure supply to the robot, before entering the robot working area.	
2	Make sure no additional stops are damaged.	Shown in figure Location of mechanical stops on page 146 .
3	Make sure the stops are properly attached. Correct tightening torque, additional mechanical stops: <ul style="list-style-type: none">• Axis 1 = 120 Nm.• Axes 2 and 3 = 115 Nm	
4	If any damage is detected, the mechanical stops must be replaced. Correct attachment screws: <ul style="list-style-type: none">• Axis 1: M16 x 35, quality 12.9.• Axis 2: M16 x 50• Axis 3: M16 x 60	Article number is specified in Required equipment on page 147 .

3.3.13 Inspecting the damper on axes 2-5

Location of dampers

The figure below shows the location of all the dampers to be inspected.

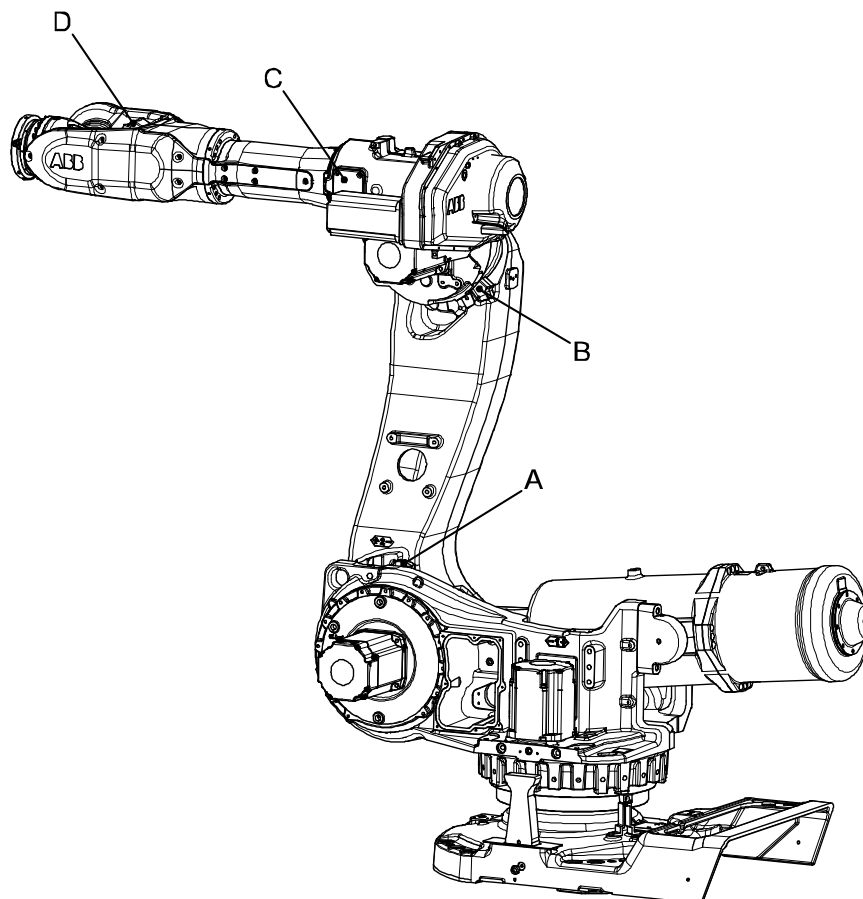

xx0400001024

A	Damper, axis 2 (2 pcs)
B	Damper, axis 3 (2 pcs)
C	Damper, axis 4 (1 pc)
D	Damper, axis 5 (2 pcs)

Required equipment

A damper must be replaced if damaged!

Equipment	Spare part/ art. no.	Note
Damper axis 2	3HAC12991-1	
Damper axis 3	3HAC12320-1	
Damper axis 4	3HAC13564-1	
Standard toolkit	3HAC15571-1	Content is defined in section Standard tools on page 406 .

Continues on next page

3 Maintenance

3.3.13 Inspecting the damper on axes 2-5

Continued

Inspection, dampers

The procedure below details how to inspect the dampers, axes 2-5.

	Action	Note
1	 DANGER Turn off all: <ul style="list-style-type: none">• electric power supply• hydraulic pressure supply• air pressure supply to the robot, before entering the safeguarded space.	
2	Check all <i>dampers</i> for damage, and for cracks or existing impressions larger than 1 mm. To inspect the damper axis 4, remove the two covers on top of the upper arm!	Shown in the figure Location of dampers on page 149 .
3	Check attachment screws for deformation.	
4	If any damage is detected, the damper must be replaced with a new one!	Art. no. is specified in Required equipment on page 149 .

3.3.14 Inspecting, signal lamp

Location of signal lamp

The signal lamp is located as shown in figure below. Note that the position can differ depending on how the customer harness for axis 4-6 is mounted. See assembly drawing on the current harness for alternative positioning.

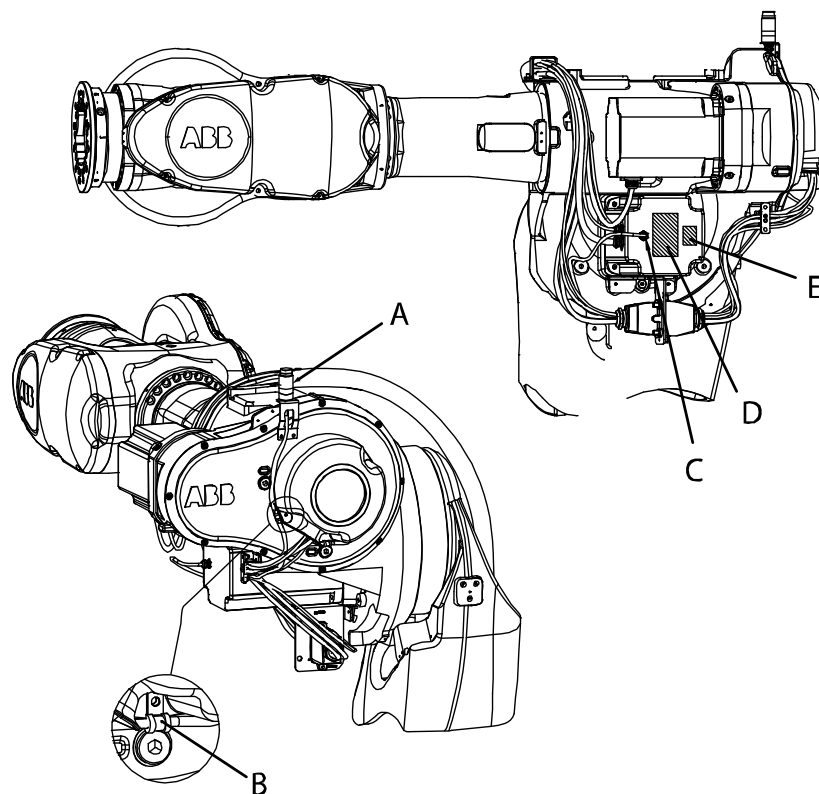

xx020000240

A	Signal lamp
B	Clamp
C	Position for cable gland
D	Warning label on motor cover
E	Warning sign on motor cover

Required equipment

Equipment, etc.	Art. no.	Note
Signal lamp	3HAC10830-1	To be replaced in case of detected damage.
Standard toolkit	-	Content is defined in section Standard tools on page 406 .
Other tools and procedures may be required. See references to these procedures in the step-by-step instructions below.		These procedures include references to the tools required.

Continues on next page

3 Maintenance

3.3.14 Inspecting, signal lamp

Continued

Inspecting, signal lamp

Use this procedure to inspect the function of the signal lamp.

	Action	Note
1	Check that signal lamp is lit when motors are put in operation ("MOTORS ON").	
2	 DANGER Turn off all: <ul style="list-style-type: none">• electric power supply to the robot• hydraulic pressure supply to the robot• air pressure supply to the robot Before entering the robot working area.	
3	If the lamp is not lit, trace the fault by: <ul style="list-style-type: none">• Checking whether the <i>signal lamp</i> is broken. If so, replace it.• Checking cable connections.• Measuring the voltage in connectors motor axis 3 (=24V).• Checking the cabling. Replace cabling if a fault is detected.	Art. no. is specified in Required equipment on page 151 .

3.4 Replacement/changing activities

3.4.1 Type of lubrication in gearboxes

Introduction

This section describes where to find information about the type of lubrication, article number and the amount of lubrication in the specific gearbox. It also describes the equipment needed when working with lubrication.

Type and amount of oil in gearboxes

Information about the type of lubrication, article number as well as the amount in the specific gearbox can be found in *Technical reference manual - Lubrication in gearboxes* available for registered users on myABB Business Portal, www.abb.com/myABB.

Location of gearboxes

The figure shows the location of the gearboxes.

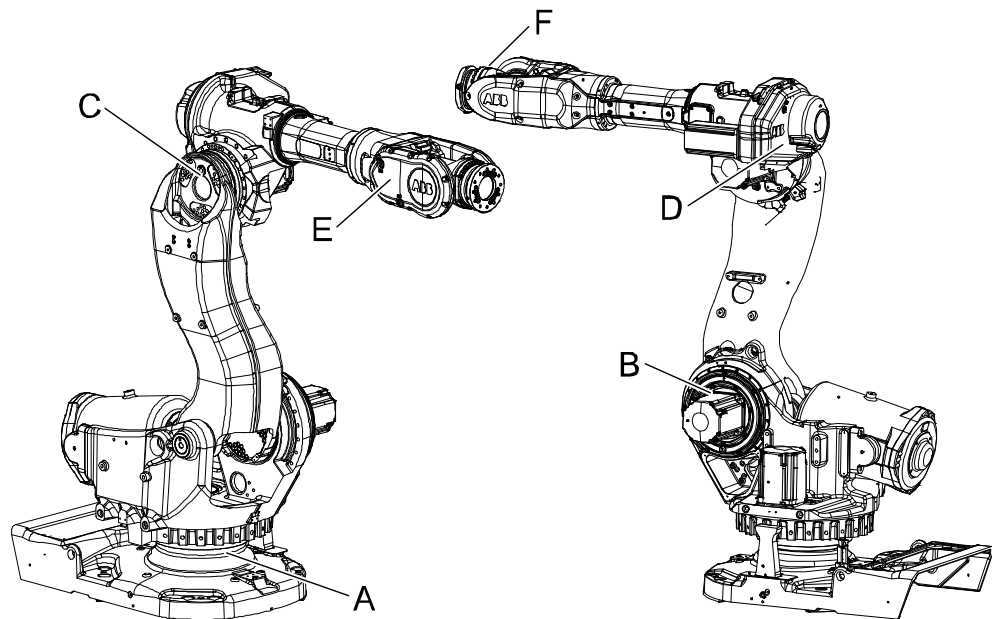

xx0800000247

A	Axis 1 gearbox
B	Axis 2 gearbox
C	Axis 3 gearbox
D	Axis 4 gearbox
E	Axis 5 gearbox
F	Axis 6 gearbox

Continues on next page

3 Maintenance

3.4.1 Type of lubrication in gearboxes

Continued

Equipment

Equipment	Note
Oil dispenser	Includes pump with outlet pipe. Use the suggested dispenser or a similar one: <ul style="list-style-type: none">• Orion OriCan article number 22590 (pneumatic)
Nipple for quick connect fitting, with o-ring	

3.4.2 Changing oil, axis-1 gearbox

Location of oil plugs

The axis-1 gearbox is located between the frame and base. See oil plugs in the following figure.

The oil is drained through a hose, which is located at the rear of the robot base.

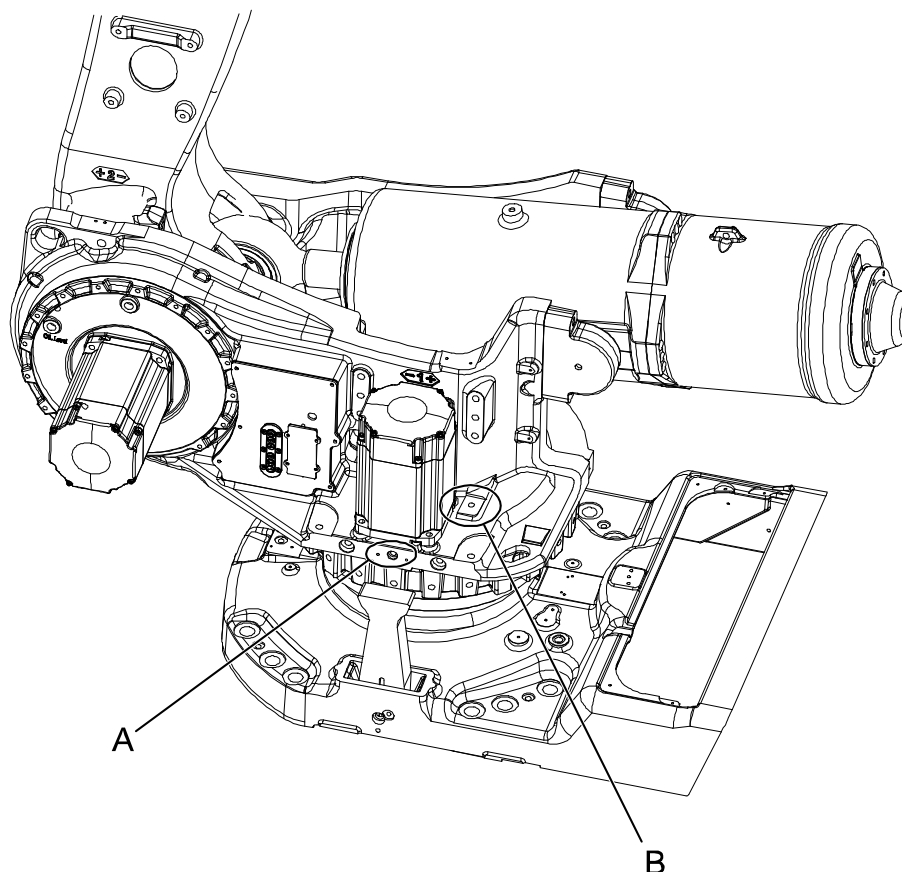

xx0300000583

A	Oil plug, inspection
B	Oil plug, filling

Required equipment

Equipment, etc.	Art. no.	Amount	Note
Lubricating oil	See <i>Type and amount of oil in gearboxes on page 153.</i>	See <i>Type and amount of oil in gearboxes on page 153.</i>	 Note Do not mix with other oils!
Oil collecting vessel	-		Capacity: 8,000 ml.
Oil exchange equipment	3HAC021745-001		Content is defined in section <i>Special tools on page 407.</i>

Continues on next page

3 Maintenance

3.4.2 Changing oil, axis-1 gearbox

Continued





Equipment, etc.	Art. no.	Amount	Note
Standard toolkit	-		Content is defined in section Standard tools on page 406 .

Draining oil, axis-1 gearbox

Use this procedure to drain the oil in gearbox axis 1.

When using oil exchange equipment, follow the instructions enclosed with the kit.

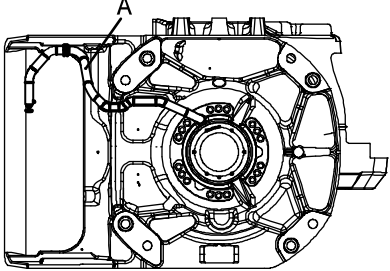
Art. no. for the kit is specified in [Required equipment on page 155](#).



	Action	Note
1	 DANGER Turn off all: <ul style="list-style-type: none"> • electric power supply • hydraulic pressure supply • air pressure supply to the robot, before entering the safeguarded space.	
2	 WARNING Handling gearbox oil involves several safety risks, see Gearbox lubricants (oil or grease) on page 36 .	
3	Remove rear cover on the base by unscrewing its attachment screws.	
4	Pull out the draining hose from the rear of the base.	 <p>xx0200000237</p> <p>The hose is located beneath the base, seen from below. A Oil draining hose</p>
5	Place an oil vessel close to hose end.	Vessel capacity is specified in Required equipment on page 155 .
6	Remove <i>oil plug, filling</i> in order to drain oil quicker!	Shown in figure Location of oil plugs on page 155 .
7	Open the hose end and drain the oil into a vessel.  CAUTION Drain as much oil as possible.	 Note Draining is time-consuming. Elapsed time depends on the temperature of the oil.

Continues on next page

	Action	Note
8	Close the oil drain hose, and put it back inside the base.	
9	Refit rear cover by securing it with its attachment screws.	

Filling oil, axis-1 gearbox

Use this procedure to fill gearbox axis 1 with oil.

	Action	Note
1	 DANGER Turn off all: <ul style="list-style-type: none"> • electric power supply • hydraulic pressure supply • air pressure supply to the robot, before entering the safeguarded space.	
2	 WARNING Handling gearbox oil involves several safety risks, see Gearbox lubricants (oil or grease) on page 36 .	
3	Open the <i>oil plug, filling</i> .	Shown in figure Location of oil plugs on page 155 .
4	Refill the gearbox with clean <i>lubricating oil</i> . The correct oil level is detailed in section Inspecting the oil level in axis-1 gearbox on page 117 .	Where to find type of oil and total amount is detailed in Type and amount of oil in gearboxes on page 153 .
5	 WARNING Do not mix oil types! If wrong oil is refilled, the gearbox must be rinsed as detailed in <i>Technical reference manual - Lubrication in gearboxes</i> .	
6	Refit the oil plug, filling.	Tightening torque: 24 Nm.

3 Maintenance

3.4.3 Changing oil, axis-2 gearbox

3.4.3 Changing oil, axis-2 gearbox

Location of oil plugs

The axis-2 gearbox is located in the lower arm rotational center, underneath the motor attachment.

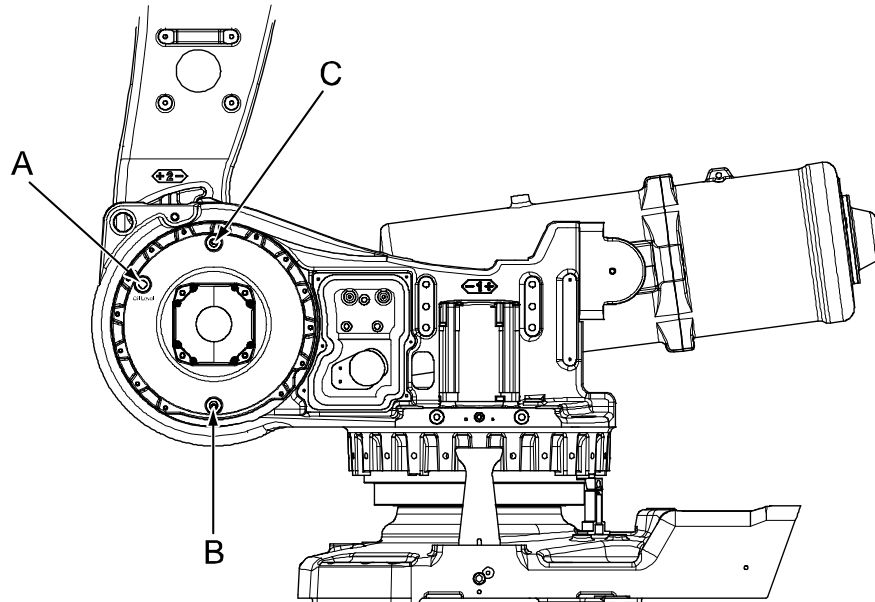

xx030000631

A	Oil plug, filling
B	Oil plug, draining
C	Vent hole

Required equipment





Equipment, etc.	Art. no.	Amount	Note
Lubricating oil	See <i>Type and amount of oil in gearboxes on page 153.</i>	See <i>Type and amount of oil in gearboxes on page 153.</i>	Note! Do not mix with other oil types!
Oil collecting vessel	-		Capacity: 6,000 ml.
Oil exchange equipment	3HAC021745-001		Content is defined in section <i>Special tools on page 407.</i>
Standard toolkit	-		Content is defined in section <i>Standard tools on page 406.</i>

Continues on next page

Draining, oil

The procedure below details how to drain the oil in gearbox axis 2.

When using the oil exchange equipment, follow the instructions enclosed with the kit. Art. no. for the kit is specified in [Required equipment on page 158](#).

	Action	Note
1	 DANGER Turn off all: <ul style="list-style-type: none"> • electric power supply to the robot • hydraulic pressure supply to the robot • air pressure supply to the robot Before entering the robot working area.	
2	 WARNING Handling gearbox oil involves several safety risks, see Gearbox lubricants (oil or grease) on page 36 .	
3	Remove the plug of the <i>filling/inspection hole</i> .	Shown in the figure Location of oil plugs on page 158 .
4	Remove the <i>oil plug, draining</i> , and drain the gearbox oil using a hose with nipple and an oil collecting vessel.  CAUTION Drain as much oil as possible.	Shown in the figure Location of oil plugs on page 158 . Vessel capacity is specified in Required equipment on page 158 .  Note Draining is time-consuming. Elapsed time varies depending on the temperature of the oil.
5	Refit the oil plug.	Tightening torque: 24 Nm.

Filling, oil

Use this procedure to fill oil into the axis-2 gearbox.

When using the oil exchange equipment, follow the instructions enclosed with the kit. Art. no. for the kit is specified in [Required equipment on page 158](#).



	Action	Note
1	 DANGER Turn off all: <ul style="list-style-type: none"> • electric power supply to the robot • hydraulic pressure supply to the robot • air pressure supply to the robot Before entering the robot working area.	

Continues on next page

3 Maintenance

3.4.3 Changing oil, axis-2 gearbox

Continued

	Action	Note
2	 WARNING Handling gearbox oil involves several safety risks, see Gearbox lubricants (oil or grease) on page 36 .	
3	Remove the <i>oil plug for filling</i> and the plug from the <i>vent hole</i> .	Shown in the figure Location of oil plugs on page 158 .
4	Refill the gearbox with clean <i>lubricating oil</i> . The correct oil level is detailed in section Inspecting the oil level in axis-2 gearbox on page 119 .	Where to find type of oil and total amount is detailed in Type and amount of oil in gearboxes on page 153 .
5	 WARNING Do not mix oil types! If wrong oil is refilled, the gearbox must be rinsed as detailed in <i>Technical reference manual - Lubrication in gearboxes</i> .	
6	Refit the oil plug and the plug in the vent hole.	Tightening torque: 24 Nm.

3.4.4 Changing oil, axis-3 gearbox

Location of gearbox

The axis-3 gearbox is located in the upper arm rotational center as shown in the following figure.

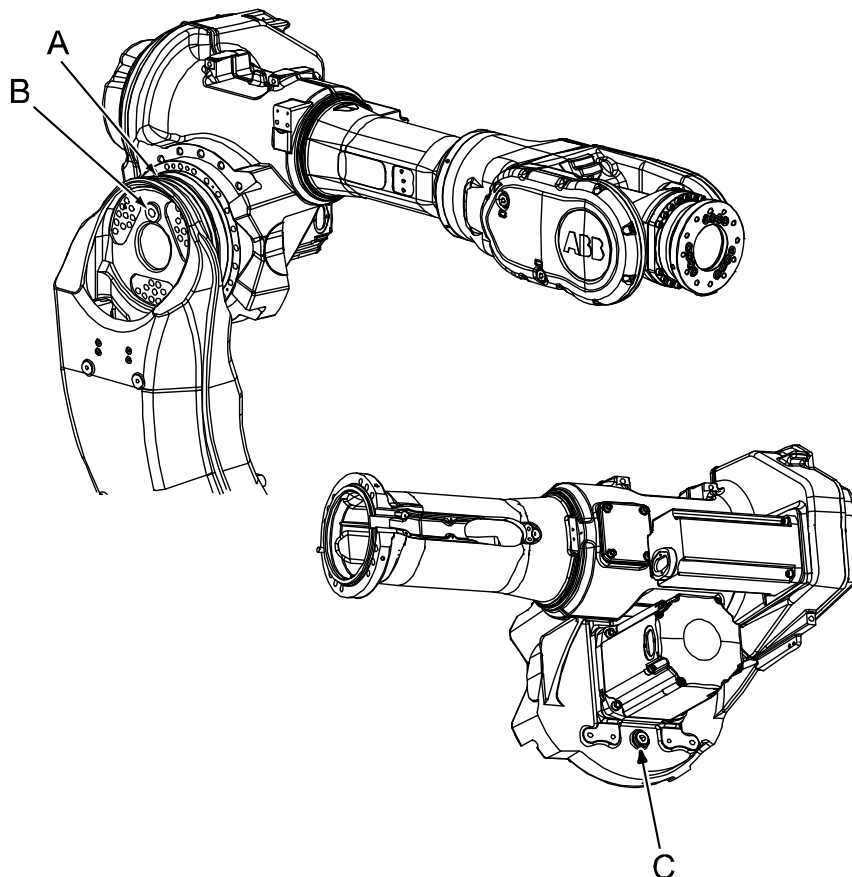

xx020000230

A	Gearbox axis 3
B	Oil plug, filling
C	Oil plug, draining

Required equipment

Equipment, etc.	Art. no.	Amount	Note
Lubricating oil	See <i>Type and amount of oil in gearboxes on page 153.</i>	See <i>Type and amount of oil in gearboxes on page 153.</i>	Note! Do not mix with other oil types!
Oil exchange equipment	3HAC021745-001		Content is defined in section <i>Special tools on page 407.</i>
Oil collecting vessel	-		Capacity: 3,000 ml.

Continues on next page

3 Maintenance

3.4.4 Changing oil, axis-3 gearbox





Continued

Equipment, etc.	Art. no.	Amount	Note
Standard toolkit	-		Content is defined in section Standard tools on page 406 .

Draining, oil

The procedure below details how to drain oil from the gearbox, axis 3.

When using the oil exchange equipment, follow the instructions enclosed with the kit. Art. no. for the kit is specified in [Required equipment on page 161](#).





	Action	Note
1	 DANGER Turn off all: <ul style="list-style-type: none"> • electric power supply to the robot • hydraulic pressure supply to the robot • air pressure supply to the robot Before entering the robot working area.	
2	 WARNING Handling gearbox oil involves several safety risks, see Gearbox lubricants (oil or grease) on page 36 .	
3	Remove the <i>oil plug, filling</i> .	
4	Remove the <i>oil plug, draining</i> , and drain the gearbox oil using a hose with nipple and an oil collecting vessel.  CAUTION Drain as much oil as possible.	Shown in the figure Location of gearbox on page 161 . Vessel capacity is specified in Required equipment on page 161 .  Note Draining is time-consuming. Elapsed time varies depending on the temperature of the oil.
5	Refit the oil plug.	Tightening torque: 24 Nm.

Continues on next page

Filling, oil

The procedure below details how to fill oil into the gearbox, axis 3.

When using the oil exchange equipment, follow the instructions enclosed with the kit. Art. no. for the kit is specified in [Required equipment on page 161](#).

	Action	Note
1	 DANGER Turn off all: <ul style="list-style-type: none"> • electric power supply to the robot • hydraulic pressure supply to the robot • air pressure supply to the robot Before entering the robot working area.	
2	 WARNING Handling gearbox oil involves several safety risks, see Gearbox lubricants (oil or grease) on page 36 .	
3	Remove the <i>oil plug, filling</i> .	Shown in the figure Location of gearbox on page 161 .
4	Refill the gearbox with clean <i>lubricating oil</i> . The correct oil level is detailed in section Inspecting the oil level in axis-3 gearbox on page 121 .	Where to find type of oil and total amount is detailed in Type and amount of oil in gearboxes on page 153 .
5	 WARNING Do not mix oil types! If wrong oil is refilled, the gearbox must be rinsed as detailed in <i>Technical reference manual - Lubrication in gearboxes</i> .	
6	 Note Do not mix Kyodo Yushi TMO 150 with other oil types!	
7	Refit the oil plug.	Tightening torque: 24 Nm.

3 Maintenance

3.4.5 Changing oil, axis-4 gearbox

3.4.5 Changing oil, axis-4 gearbox

Location of gearbox

The axis 4 gearbox is located in the rearmost part of the upper arm as shown in the figure below.

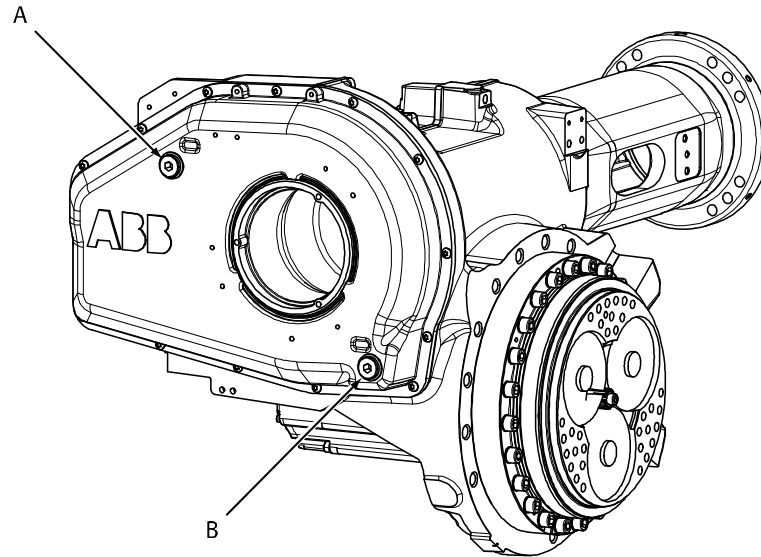

xx020000231

A	Oil plug, filling
B	Oil plug, draining

Required equipment

Equipment, etc.	Art. no.	Amount	Note
Lubricating oil	See Type and amount of oil in gearboxes on page 153 .	See Type and amount of oil in gearboxes on page 153 .	
Oil exchange equipment	3HAC021745-001		Content is defined in section Special tools on page 407 .
Oil collecting vessel	-		Capacity: 9,000 ml.
Standard toolkit	-		Content is defined in section Standard tools on page 406 .



Draining, oil

The procedure below details how to drain the oil in the gearbox, axis 4.

When using the oil exchange equipment, follow the instructions enclosed with the kit. Art. no. for the kit is specified in [Required equipment on page 164](#).

	Action	Note
1	Run the upper arm -45° from the calibration position.	



Continues on next page

	Action	Note
2	 DANGER Turn off all: <ul style="list-style-type: none"> • electric power supply to the robot • hydraulic pressure supply to the robot • air pressure supply to the robot Before entering the robot working area.	
3	 WARNING Handling gearbox oil involves several safety risks, see Gearbox lubricants (oil or grease) on page 36 .	
4	Remove the <i>oil plug, filling</i> .	
5	Drain the oil from the gearbox into a vessel by opening the <i>oil plug, draining</i> .	Shown in the figure Location of gearbox on page 164 . Vessel capacity is specified in Required equipment on page 164 .
6	Run the upper arm back to its calibration position (horizontal position).	This is detailed in section Synchronization marks and synchronization position for axes on page 364 .
7	Refit the oil plug, draining.	Tightening torque: 24 Nm.

Filling, oil

The procedure below details how to fill the oil in the gearbox, axis 4.

When using the oil exchange equipment, follow the instructions enclosed with the kit. Art. no. for the kit is specified in [Required equipment on page 164](#).

	Action	Note
1	 DANGER Turn off all: <ul style="list-style-type: none"> • electric power supply to the robot • hydraulic pressure supply to the robot • air pressure supply to the robot Before entering the robot working area.	
2	 WARNING Handling gearbox oil involves several safety risks, see Gearbox lubricants (oil or grease) on page 36 .	
3	Refill the gearbox with clean <i>lubricating oil</i> . The correct oil level is detailed in section Inspecting the oil level in axis-4 gearbox on page 124 .	Shown in the figure Location of gearbox on page 164 . Where to find type of oil and total amount is detailed in Type and amount of oil in gearboxes on page 153 .

Continues on next page

3 Maintenance

3.4.5 Changing oil, axis-4 gearbox

Continued

	Action	Note
4	 WARNING Do not mix oil types! If wrong oil is refilled, the gearbox must be rinsed as detailed in <i>Technical reference manual - Lubrication in gearboxes</i> .	
5	Refit the oil plug, filling.	Tightening torque: 24 Nm.

3.4.6 Changing oil, axis-5 gearbox

Location of gearbox

The axis 5 gearbox is located in the wrist unit as shown in the figure below.

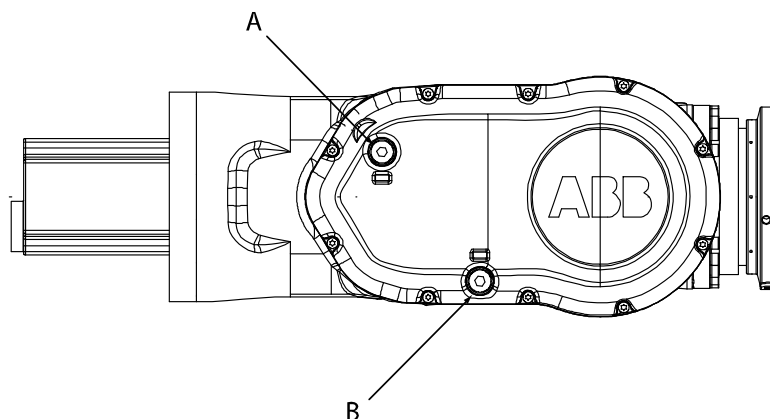

xx020000232

-	Wrist unit of IRB 6600 and IRB 6650
A	Oil plug, filling
B	Oil plug, draining

Required equipment

Equipment, etc.	Art. no.	Amount	Note
Lubricating oil	See <i>Type and amount of oil in gearboxes on page 153.</i>	See <i>Type and amount of oil in gearboxes on page 153.</i>	
Oil exchange equipment	3HAC021745-001		Content is defined in section <i>Special tools on page 407.</i>
Oil collecting vessel	-		Capacity: 7,000 ml.
Standard toolkit	-		Content is defined in section <i>Standard tools on page 406.</i>

Draining, oil, axis 5

The procedure below details how to change the oil in gearbox, axis 5.

When using the oil exchange equipment, follow the instructions enclosed with the kit. Art. no. for the kit is specified in *Required equipment on page 167.*



	Action	Note
1	Run axis 4 to a position where the oil plug for draining is facing downwards.	

Continues on next page

3 Maintenance

3.4.6 Changing oil, axis-5 gearbox



Continued

	Action	Note
2	 DANGER Turn off all: <ul style="list-style-type: none"> • electric power supply to the robot • hydraulic pressure supply to the robot • air pressure supply to the robot Before entering the robot working area.	
3	 WARNING Handling gearbox oil involves several safety risks, see Gearbox lubricants (oil or grease) on page 36 .	
4	Remove the <i>oil plug, filling</i> .	
5	Drain the oil from the gearbox by opening the <i>oil plug, draining</i> .	Shown in the figure Location of gearbox on page 167 . Vessel capacity is specified in Required equipment on page 167 .
6	Refit the oil plug, draining.	Tightening torque: 24 Nm.

Filling, oil, axis 5

The procedure below details how to change the oil in gearbox, axis 5.

When using the oil exchange equipment, follow the instructions enclosed with the kit. Art. no. for the kit is specified in [Required equipment on page 167](#).

	Action	Note
1	Run axis 4 to a position where the oil plug, filling, is facing upwards.	
2	 WARNING Handling gearbox oil involves several safety risks, see Gearbox lubricants (oil or grease) on page 36 .	
3	 DANGER Turn off all: <ul style="list-style-type: none"> • electric power supply to the robot • hydraulic pressure supply to the robot • air pressure supply to the robot Before entering the robot working area.	
4	Refill the gearbox with clean <i>lubricating oil</i> . The correct oil level is detailed in section Inspecting the oil level in axis-5 gearbox on page 126 .	Shown in the figure Location of gearbox on page 167 . Where to find type of oil and total amount is detailed in Type and amount of oil in gearboxes on page 153 .

Continues on next page

	Action	Note
5	 WARNING Do not mix oil types! If wrong oil is refilled, the gearbox must be rinsed as detailed in <i>Technical reference manual - Lubrication in gearboxes</i> .	
6	Refit the oil plug, filling.	Tightening torque: 24 Nm.

3 Maintenance

3.4.7 Changing oil, axis-6 gearbox

3.4.7 Changing oil, axis-6 gearbox

Location of gearbox

The axis 6 gearbox is located in the center of the wrist unit as shown in the figure below.

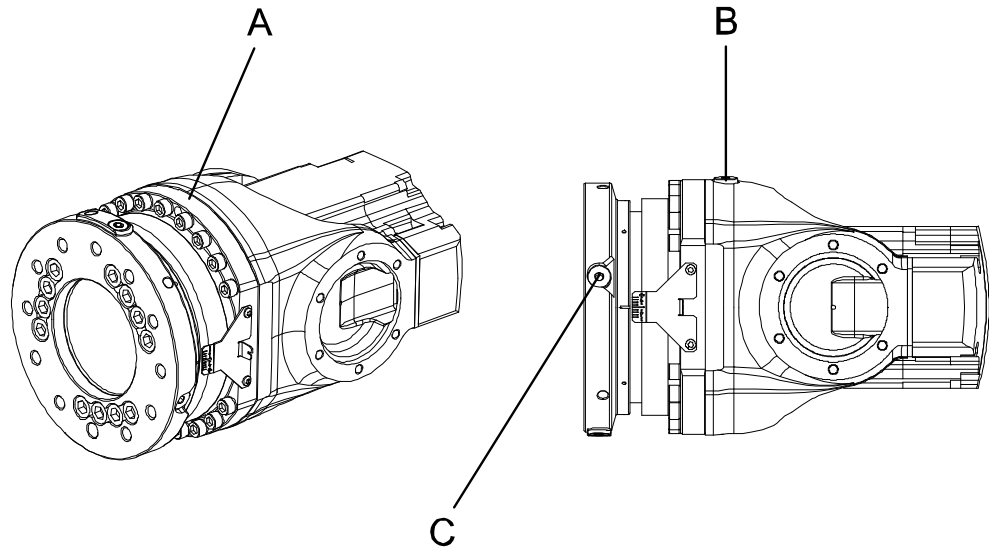

xx0400001092

-	The figure above shows the wrist unit .
A	Gearbox, axis 6
B	Oil plug, filling
C	Oil plug, draining

Required equipment



Equipment, etc.	Art. no.	Amount	Note
Lubricating oil	See <i>Type and amount of oil in gearboxes on page 153.</i>	See <i>Type and amount of oil in gearboxes on page 153.</i>	 Note Do not mix with other oils!
Oil exchange equipment	3HAC021745-001		Content is defined in section <i>Special tools on page 407.</i>
Oil collecting vessel	-		Vessel capacity: 500 ml
Standard toolkit	-		Content is defined in section <i>Standard tools on page 406.</i>

Continues on next page

Draining, oil, axis 6

The procedure below details how to drain oil from the gearbox, axis 6.



When using the oil exchange equipment, follow the instructions enclosed with the kit. Art. no. for the kit is specified in [Required equipment on page 170](#).

	Action	Note
1	Run the robot to a position where the <i>oil plug, filling</i> of axis 6 gearbox is facing downwards.	Shown in the figure Location of gearbox on page 170 .
2	 DANGER Turn off all: <ul style="list-style-type: none"> • electric power supply to the robot • hydraulic pressure supply to the robot • air pressure supply to the robot Before entering the robot working area.	
3	 WARNING Handling gearbox oil involves several safety risks, see Gearbox lubricants (oil or grease) on page 36 .	
4	Drain the oil from the gearbox into a vessel by removing the oil plug.	Vessel capacity is specified in Required equipment on page 170 .
	Measure the amount of oil drained.	The amount of oil to be refilled depends on the amount previously drained.
5	Refit the <i>oil plug, draining</i> .	Tightening torque: 24 Nm.

Filling, oil, axis 6

The procedure below details how to fill oil into the gearbox, axis 6.

When using the oil exchange equipment, follow the instructions enclosed with the kit. Art. no. for the kit is specified in [Required equipment on page 170](#).

	Action	Note
1	 DANGER Turn off all: <ul style="list-style-type: none"> • electric power supply to the robot • hydraulic pressure supply to the robot • air pressure supply to the robot Before entering the robot working area.	
2	 WARNING Handling gearbox oil involves several safety risks, see Gearbox lubricants (oil or grease) on page 36 .	
3	Remove the <i>oil plug, filling</i> .	Shown in the figure Location of gearbox on page 170 .

Continues on next page

3 Maintenance

3.4.7 Changing oil, axis-6 gearbox

Continued

	Action	Note
4	Refill the gearbox with clean <i>lubricating oil</i> . The correct oil level is detailed in section <i>Inspecting the oil level in axis-6 gearbox on page 128</i> .	Where to find type of oil and total amount is detailed in <i>Type and amount of oil in gearboxes on page 153</i> .
5	 WARNING Do not mix oil types! If wrong oil is refilled, the gearbox must be rinsed as detailed in <i>Technical reference manual - Lubrication in gearboxes</i> .	
6	Refit the oil plug.	Tightening torque: 24 Nm.
	Inspect the oil level.	Detailed in the section <i>Inspecting the oil level in axis-6 gearbox on page 128</i> .

3.4.8 Replacing the SMB battery

**Note**

The battery low alert (38213 Battery charge low) is displayed when the battery needs to be replaced. The recommendation to avoid an unsynchronized robot is to keep the power to the controller turned on until the battery is to be replaced.

For a SMB board with 3-pole battery contact (RMU101 3HAC044168-001 or RMU102 3HAC043904-001), the lifetime of a new battery is typically 36 months.

For a SMB board with 2-pole battery contact (DSQC), the typical lifetime of a new battery is 36 months if the robot is powered off 2 days/week or 18 months if the robot is powered off 16 h/day. The lifetime can be extended for longer production breaks with a battery shutdown service routine. See the operating manual for the robot controller for instructions.

**WARNING**

See [Hazards related to batteries on page 38](#).

Location of SMB battery

The SMB battery (SMB = serial measurement board) is located on the left hand side of the frame as shown in the figure.

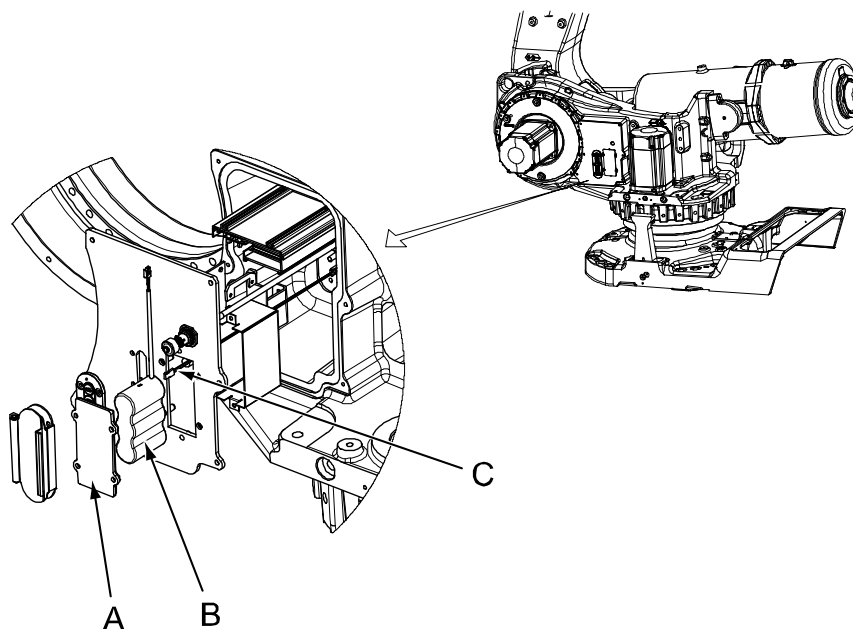
Battery pack with a 2-pole battery contact (DSQC)

xx0300000559

A	SMB Battery cover
B	SMB battery pack with 2-pole battery contact.
C	Battery cable

Continues on next page

3 Maintenance

3.4.8 Replacing the SMB battery

Continued

Battery pack with a 3-pole battery contact (RMU)

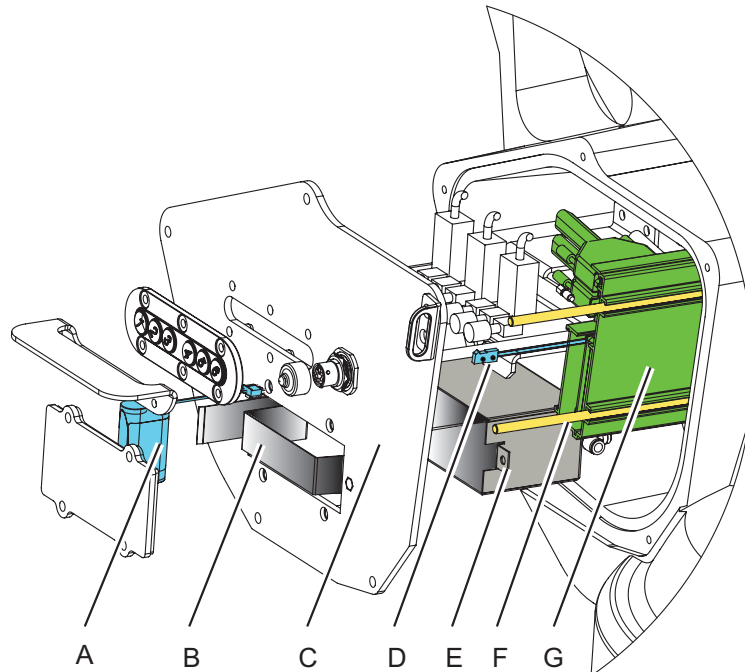

xx1400002574

A	Battery pack RMU
B	Holder for battery
C	SMB cover
D	Battery cable
E	Battery holder
F	Guide pin (2 pcs)
G	SMB unit

Required equipment



Note

There are two variants of SMB units and batteries. One with 2-pole battery contact (DSQC) and one with 3-pole battery contact (RMU). The variant with the 3-pole battery contact has longer lifetime for the battery.

It is important that the SMB unit uses the correct battery. Make sure to order the correct spare parts. Do not exchange battery contacts!



Equipment, etc.	Spare part no.	Note
Battery unit	For spare part no. see: <ul style="list-style-type: none"> Spare part lists on page 397 	Battery includes protection circuits. Only replace with a specified spare part or an ABB-approved equivalent.
Standard toolkit	-	Content is defined in section Standard tools on page 406 .

Continues on next page

Equipment, etc.	Spare part no.	Note
Circuit diagram	-	See chapter Circuit diagram on page 411 .

Removing, battery

Use this procedure to remove the SMB battery.

	Action	Note
1	Move the robot to its calibration position.	This is done in order to facilitate updating of the revolution counter.
2	 DANGER Turn off all: <ul style="list-style-type: none"> • electric power supply • hydraulic pressure supply • air pressure supply to the robot, before entering the safeguarded space.	
3	 ELECTROSTATIC DISCHARGE (ESD) The unit is sensitive to ESD. Before handling the unit please read the safety information in the section The unit is sensitive to ESD on page 54	
4	Remove the <i>SMB battery cover</i> by unscrewing the attachment screws.  CAUTION Clean cover from metal residues before opening. Metal residues can cause shortage on the boards which can result in hazardous failures.	Shown in figure Location of SMB battery on page 173 .
5	Pull out the battery and disconnect the <i>battery cable</i> .	Shown in figure Location of SMB battery on page 173 .
6	Remove the <i>SMB battery</i> . Battery includes protection circuits. Only replace with a specified spare part or with an ABB- approved equivalent.	Shown in figure Location of SMB battery on page 173 .

Continues on next page





3 Maintenance

3.4.8 Replacing the SMB battery

Continued

Refitting, battery

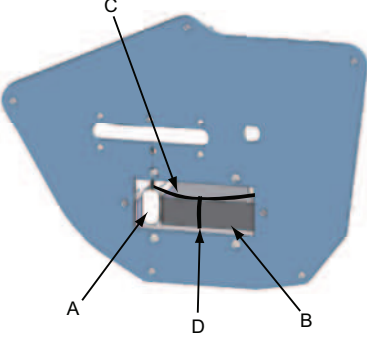
Use this procedure to refit the SMB battery.

	Action	Note
1	 <p>DANGER</p> <p>Turn off all:</p> <ul style="list-style-type: none"> • electric power supply • hydraulic pressure supply • air pressure supply <p>to the robot, before entering the safeguarded space.</p>	
2	 <p>ELECTROSTATIC DISCHARGE (ESD)</p> <p>The unit is sensitive to ESD. Before handling the unit please read the safety information in the section The unit is sensitive to ESD on page 54</p>	
3	<p>Reconnect the <i>battery cable</i> and install the battery pack into the SMB/battery recess.</p> <p> Note</p> <p>RMU batteries are installed together with a battery holder to be properly secured inside the recess. See figure.</p> <p>Strap the battery cable to the holder.</p>	<p>Art. no. is specified in Required equipment on page 174.</p> <p>Shown in figure Location of SMB battery on page 173.</p>  <p>xx1300000307</p> <p>A Battery pack RMU B Battery holder C Battery cable D Strap</p>
4	Secure the <i>SMB battery cover</i> with its attachment screws.	Shown in figure Location of SMB battery on page 173 .
5	Update the revolution counters.	Detailed in chapter Calibration - section Updating revolution counters on IRC5 robots on page 366 .
6	 <p>DANGER</p> <p>Make sure all safety requirements are met when performing the first test run. See Test run after installation, maintenance, or repair on page 108.</p>	

3.5 Lubrication activities

3.5.1 Lubrication of spherical roller bearing, balancing device

Location of bearing

The spherical roller bearing is located at the front ear of the balancing device, as shown in the figure below.

Note! The balancing device must be mounted on the robot when lubricating the bearing!

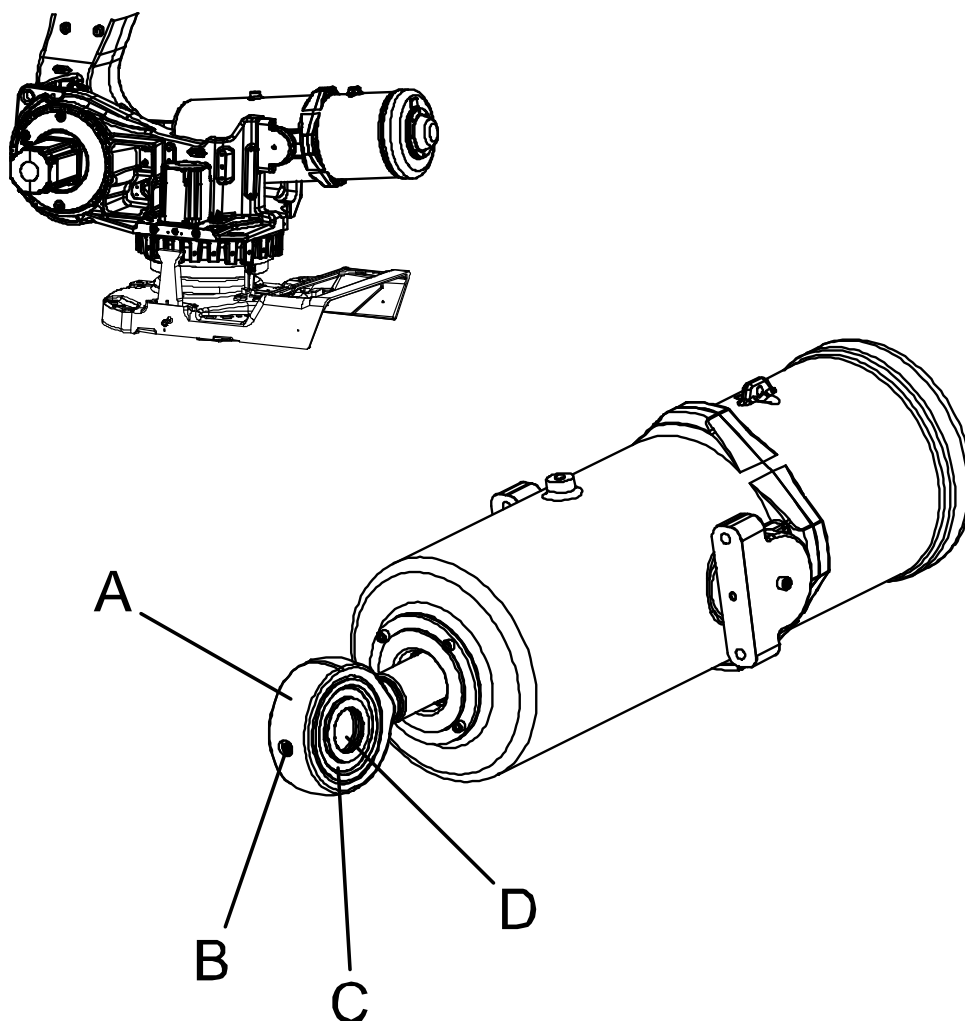

xx040000721

A	Ear (spherical roller bearing located inside)
B	Securing screw
C	Sealing spacer
D	Hole through which the shaft is pressed

Continues on next page

3 Maintenance

3.5.1 Lubrication of spherical roller bearing, balancing device

Continued

Required equipment

Equipment, etc.	Art. no.	Note
Grease	3HAC042534-001	Tribol GR 100-0-PD, 150 ml
Lubrication nipple		M6. Normally fitted to the link ear at delivery.
Grease pump	-	

Lubrication, balancing device bearing

The procedure below details how to lubricate the spherical roller bearing.

	Action	Note
1	 <p>DANGER</p> <p>Turn off all:</p> <ul style="list-style-type: none"> • electric power supply • hydraulic pressure supply • air pressure supply <p>to the robot, before entering the safeguarded space.</p>	
2	Replace the securing screw at the link ear with a lubrication nipple.	M6
3	Lubricate the spherical roller bearing through the lubrication nipple in the ear with <i>grease</i> , approximately 5 grams.	Art. no. and amount is specified in Required equipment on page 178 ! Shown in the figure Location of bearing on page 177 ! The balancing device must be mounted on the robot when lubricating the bearing!
4	Remove the lubrication nipple and refit the securing screw and washer.	M6x10, washer: D=6.4/12 T=1.6 Tightening torque: 6 Nm.
5	Clean the area from any excessive grease and check the area once again after operation of the robot, in order to make sure there is no incorrect leakage from the o-rings.	Read more about the inspection in section Inspection, balancing device - Check for leakage on page 135 .

3.6 Cleaning activities

3.6.1 Cleaning the IRB 6650S



DANGER

Turn off all:

- electric power supply
- hydraulic pressure supply
- air pressure supply

to the robot, before entering the safeguarded space.

General

To secure high uptime it is important that the IRB 6650S is cleaned regularly. The frequency of cleaning depends on the environment in which the product works. Different cleaning methods are allowed depending on the type of protection of the IRB 6650S.



Note

Always verify the protection type of the robot before cleaning.

Oil spills

Oil spills from gearboxes

Use the following procedure if any oil spills are detected that can be suspected to originate from a gearbox.

- 1 Inspect that the oil level in the suspected gearbox is according to the recommendations, see [Inspection activities on page 115](#).
- 2 Write down the oil level.
- 3 Inspect the oil level again after, for example, 6 months.
- 4 If the oil level is decreased then replace the gearbox.

Special cleaning considerations

This section specifies some special considerations when cleaning the robot.

- Always use cleaning equipment as specified. Any other cleaning equipment may shorten the life of the robot.
- Always check that all protective covers are fitted to the robot before cleaning.
- Never point the water jet at connectors, joints, sealings, or gaskets.
- Do not use compressed air to clean the robot.
- Never use solvents that are not approved by ABB to clean the robot.
- Do not spray from a distance closer than 0.4 m.
- Do not remove any covers or other protective devices before cleaning the robot.

Continues on next page

3 Maintenance

3.6.1 Cleaning the IRB 6650S

Continued

Cleaning methods

The following table defines what cleaning methods are allowed depending on the protection type.

Protection type	Cleaning method			
	Vacuum cleaner	Wipe with cloth	Rinse with water	High pressure water or steam
Standard	Yes	Yes. With light cleaning detergent.	Yes. It is highly recommended that the water contains a rust-prevention solution and that the manipulator is dried afterwards.	No
Foundry Plus	Yes	Yes. With light cleaning detergent or spirit.	Yes. It is highly recommended that the water contains a rust-prevention solution.	Yes ⁱ . It is highly recommended that the water and steam contains rust preventive, without cleaning detergents.

ⁱ Perform according to section [Cleaning with water and steam on page 180](#).

Cleaning with water and steam

Instructions for rinsing with water

ABB robots with protection types *Standard*, *Foundry Plus*, *Wash*, or *Foundry Prime* can be cleaned by rinsing with water (water cleaner).¹

The following list defines the prerequisites:

- Maximum water pressure at the nozzle: 700 kN/m² (7 bar)¹
- Fan jet nozzle should be used, min. 45° spread
- Minimum distance from nozzle to encapsulation: 0.4 meters
- Maximum flow: 20 liters/min¹

¹ Typical tap water pressure and flow

Instructions for steam or high pressure water cleaning

ABB robots with protection types *Foundry Plus*, *Wash*, or *Foundry Prime* can be cleaned using a steam cleaner or high pressure water cleaner.²

The following list defines the prerequisites:

- Maximum water pressure at the nozzle: 2500 kN/m² (25 bar)
- Fan jet nozzle should be used, min. 45° spread
- Minimum distance from nozzle to encapsulation: 0.4 meters
- Maximum water temperature: 80° C

Cables

Movable cables need to be able to move freely:

- Remove waste material, such as sand, dust and chips, if it prevents cable movement.

¹ See [Cleaning methods on page 180](#) for exceptions.

² See [Cleaning methods on page 180](#) for exceptions.

Continues on next page

- Clean the cables if they have a crusty surface, for example from dry release agents.

Cooling fans

Inspect the air supply inlet of the the motor cooling fans. Clean to remove any contamination that could hinder the air supply.

This page is intentionally left blank

4 Repair

4.1 Introduction

Structure of this chapter

This chapter describes repair activities for the IRB 6650S. Each procedure contains the information required to perform the activity, for example spare parts numbers, required special tools, and materials.



WARNING

Repair activities not described in this chapter must only be carried out by ABB.

Report replaced units



Note

When replacing a part on the IRB 6650S, report to your local ABB the serial number, the article number, and the revision of both the replaced unit and the replacement unit.

This is particularly important for safety equipment to maintain the safety integrity of the installation.

Safety information

Make sure to read through the chapter [Safety on page 21](#) before commencing any service work.



Note

If the IRB 6650S is connected to power, always make sure that the IRB 6650S is connected to protective earth and a residual current device (RCD) before starting any repair work.

For more information see:

- *Product manual - OmniCore V250XT*
- *Product manual - IRC5*
- *Product manual - IRC5 Panel Mounted Controller*

4 Repair

4.2.1 Performing a leak-down test

4.2 General procedures

4.2.1 Performing a leak-down test

When to perform a leak-down test

After refitting any motor and gearbox, the integrity of all seals enclosing the gearbox oil must be tested. This is done in a leak-down test.

The gearbox must be drained of oil before performing the leak-down test.

Required equipment

Equipment, etc.	Article number	Note
Leak-down tester	-	
Leak detection spray	-	

Performing a leak-down test

	Action	Note
1	Finish the refitting procedure of the motor or gear in question, but do not refill the gearbox with oil before performing the leak-down test.	
2	Remove the upper oil plug on the gear and replace it with the leak-down tester. Regulators, which are included in the leak-down test, may be required.	
3	Use caution, apply compressed air and raise the pressure with the knob until the correct value is shown on the manometer.  CAUTION The pressure must under no circumstance be higher than 0.25 bar (20-25 kPa). Also during the time when the pressure is raised.	Correct value: 0.2-0.25 bar (20-25 kPa)
4	Disconnect the compressed air supply.	
5	Wait for approximately 8-10 minutes and make sure that no pressure loss occurs.	If the compressed air is significantly colder or warmer than the gearbox to be tested, a slight pressure increase or decrease may occur. This is quite normal.
6	If any pressure drop occurred, then localize the leak as described in step 7. If no pressure drop occurred, then remove the leak-down tester and refit the oil plug. The test is complete.	
7	Spray any suspected leak areas with the leak detection spray. Bubbles indicate a leak.	
8	When the leak has been localized, take the necessary measures to correct the leak.	

4.2.2 Mounting instructions for bearings

General

This section describes how to mount and grease different types of bearings on the robot.

Equipment

Equipment, etc.	Article number	Note
Grease	3HAC042536-001	Shell Gadus S2 Used to grease the bearings, if not specified otherwise.

Assembly of all bearings

Attend to the following instructions while mounting a bearing on the robot.

	Action	Note
1	To avoid contamination, let a new bearing remain in its wrapping until it is time for fitting.	
2	Ensure that the parts included in the bearing fitting are free from burrs, grinding waste, and other contamination. Cast components must be free of foundry sand.	
3	Bearing rings, inner rings, and roller elements must not be subjected to direct impact. The roller elements must not be exposed to any stresses during the assembly work.	

Assembly of tapered bearings

Follow the preceding instructions for the assembly of the bearings when mounting a tapered bearing on the robot.

In addition to those instructions, the following procedure must be carried out to enable the roller elements to adjust to the correct position against the race flange.

	Action	Note
1	Tension the bearing gradually until the recommended pre-tension is achieved.  Note The roller elements must be rotated a specified number of turns before pre-tensioning is carried out and also rotated during the pre-tensioning sequence.	
2	Make sure the bearing is properly aligned as this will directly affect the durability of the bearing.	

Greasing of bearings



Note

This instruction is not valid for solid oil bearings.

Continues on next page

4 Repair

4.2.2 Mounting instructions for bearings

Continued

The bearings must be greased after assembly according to the following instructions:

- The bearings must not be completely filled with grease. However, if space is available beside the bearing fitting, the bearing may be totally filled with grease when mounted, as excessive grease will be pressed out from the bearing when the robot is started.
- During operation, the bearing should be filled to 70-80% of the available volume.
- Ensure that grease is handled and stored properly to avoid contamination.

Grease the different types of bearings as following description:

- *Grooved ball bearings* must be filled with grease from both sides.
- *Tapered roller bearings* and axial needle bearings must be greased in the split condition.

4.2.3 Mounting instructions for sealings

General

This section describes how to mount different types of sealings.

Equipment

Consumable	Article number	Note
Grease	3HAC042536-001	Shell Gadus S2

Rotating sealings

The following procedures describe how to fit rotating sealings.



CAUTION

Please observe the following before commencing any assembly of sealings:

- Protect the sealing during transport and mounting, especially the main lip on radial sealings.
- Keep the sealing in its original wrappings or protect it well before actual mounting.
- The fitting of sealings and gears must be carried out on clean workbenches.
- Use a protective sleeve for the main lip during mounting, when sliding over threads, keyways or other sharp edges.

Radial sealings

A radial sealing consists of a flexible rubber lip bonded to a rigid metal case. Only one side of the sealing is static with a metal insert.

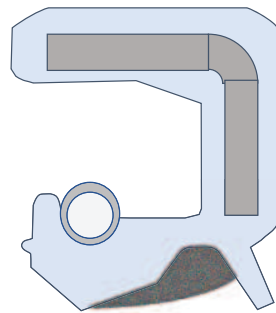

xx230000433

	Action	Note
1	Check the sealing to ensure that: <ul style="list-style-type: none"> • The sealing is of the correct type. • There is no damage on the main lip. 	
2	Inspect the shaft surface before mounting. If scratches or damage are found, the shaft must be replaced since it may result in future leakage. Do not try to grind or polish the shaft surface to get rid of the defect.	

Continues on next page

4 Repair

4.2.3 Mounting instructions for sealings

Continued

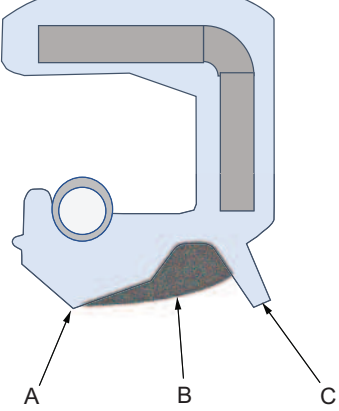
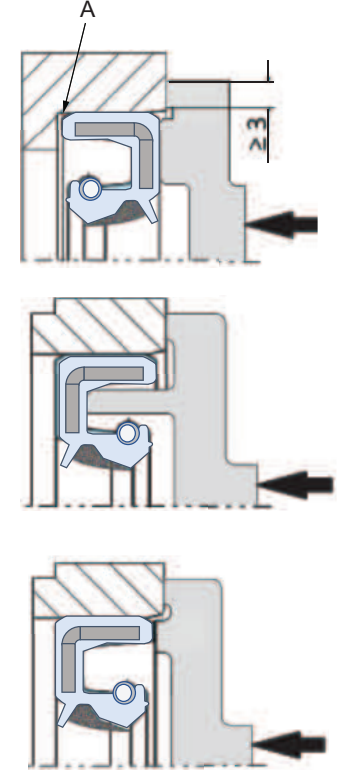
	Action	Note
3	<p>Lubricate the sealing with grease just before fitting. (Not too early - there is a risk of dirt and foreign particles adhering to the sealing.)</p> <p>Fill 2/3 of the space between the dust lip and the main lip with grease. If the sealing is without dust lip, just lubricate the main lip with a thin layer of grease.</p>	<p>Article number is specified in Equipment on page 187.</p>  <p>xx200000071</p> <p>A Main lip B Grease C Dust lip</p>
4	<p>Mount the sealing correctly with a mounting tool. Never hammer directly on the sealing as this may result in leakage.</p>	 <p>xx200000072</p> <p>A Gap</p>

Continues on next page

Flange sealings and static sealings

The following procedure describes how to fit flange sealings and static sealings.

	Action
1	Check the flange surfaces. They must be even and free from pores. It is easy to check flatness using a gauge on the fastened joint (without sealing compound). If the flange surfaces are defective, the parts may not be used because leakage could occur.
2	Clean the surfaces properly in accordance with the recommendations of ABB.
3	Distribute the sealing compound evenly over the surface.
4	Tighten the screws evenly when fastening the flange joint.

O-rings

The following procedure describes how to fit o-rings.

	Action	Note
1	Ensure that the correct o-ring size is used.	
2	Check the o-ring for surface defects, burrs, shape accuracy, or deformation.	Defective o-rings, including damaged or deformed o-rings, may not be used.
3	Check the o-ring grooves and mating surfaces. They should be free of pores, contamination and obvious scratches/damage.	
4	Lubricate the o-ring with grease.	
5	Tighten the screws evenly while assembling.	
6	Check that the o-ring is not squashed outside the o-ring groove.	

4 Repair

4.2.4 Cut the paint or surface on the robot before replacing parts

4.2.4 Cut the paint or surface on the robot before replacing parts

General

Follow the procedures in this section whenever breaking the paint of the robot during replacement of parts.

Required equipment

Equipment	Spare parts	Note
Cleaning agent		Ethanol
Knife		
Lint free cloth		
Touch up paint Standard/Foundry Plus	3HAC067974-001	Graphite White
Touch up paint Standard/Foundry Plus	3HAC037052-001	ABB Orange

Removing

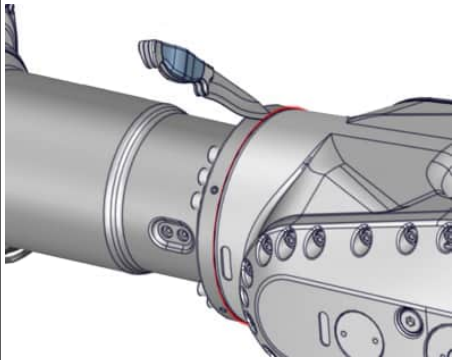
Action	Description
1 Cut the paint with a knife in the joint between the part that will be removed and the structure, to avoid that the paint cracks.	 xx2300000950
2 Carefully grind the paint edge that is left on the structure to a smooth surface.	

4.2.5 The brake release buttons may be jammed after service work

4.2.5 The brake release buttons may be jammed after service work

Description

The brake release unit has push-buttons for the brake release of each axis motor. When service work is performed inside the SMB recess that includes removal and refitting of the brake release unit, the brake release buttons may be jammed after refitting.

**DANGER**

If the power is turned on while a brake release button is jammed in depressed position, the affected motor brake is released. This may cause serious personal injuries and damage to the robot.

Elimination

To eliminate the danger after service work has been performed inside the SMB recess, follow the procedure below.

	Action
1	Make sure the power is turned off.
2	Remove the push-button guard, if necessary.
3	Verify that the push-buttons of the brake release unit are working by pressing them down, one by one. Make sure none of the buttons are jammed in the tube.
4	If a button gets jammed in the depressed position, the alignment of the brake release unit must be adjusted so that the buttons can move freely in their tubes.

4 Repair

4.3.1 Replacing cable harness, axes 1-6

4.3 Complete robot

4.3.1 Replacing cable harness, axes 1-6

General

Use this section to replace the cable harness that runs undivided from axis 1 to axis 6.

If the cabling has a division point at the upper arm, see:

- [Replacement of cable harness, axes 1-4 on page 208](#)
- [Replacement of cable harness, axes 5-6 on page 218.](#)

Location of cable harness

The cable harness of axes 1-6 is run throughout the robot as shown in the figure below.

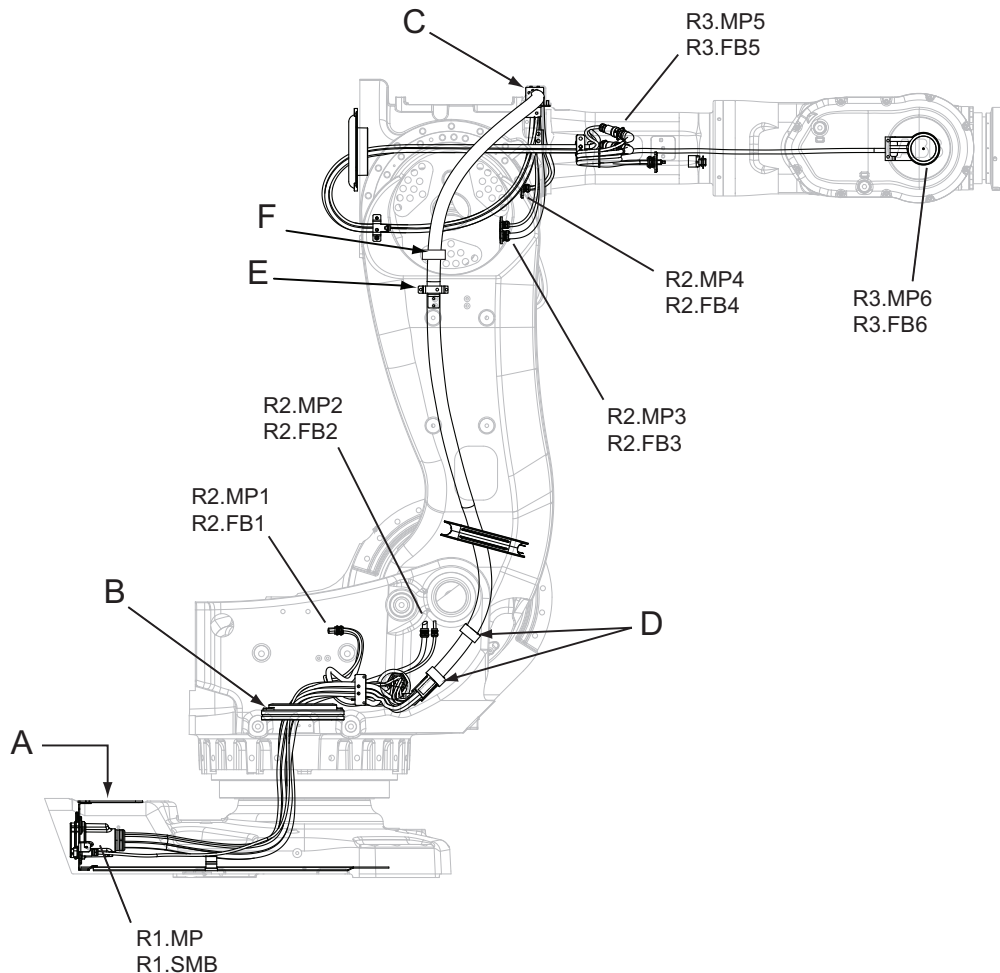

A	Rear cover plate
B	Cable guide, inside the frame
C	Cable gland, upper arm house

Continues on next page

D	Velcro straps
E	Cable gland, lower arm
F	Velcro strap (Bracket is not available on all robots.)

Required equipment

Equipment	Spare part no.	Note
Cable harness axes 1-6	3HAC075000-001	If an old version of the linear guide is installed to the robot, it must be replaced with 3HAC077402-001. Linear guide versions are shown in Linear guide on page 193 .
Gasket	3HAC12877-1	Motor axis 6
Standard toolkit	-	Content is defined in section Standard tools on page 406 .
Other tools and procedures may be required. See references to these procedures in the step-by-step instructions below.		These procedures include references to the tools required.
Circuit diagram		See chapter Circuit diagram on page 411 .

Linear guide

A linear guide is installed at the lower arm to make the cable harness run smoothly. When fitting cable harness 3HAC075000-001 to the robot, the linear guide 3HAC077402-001 must be installed.

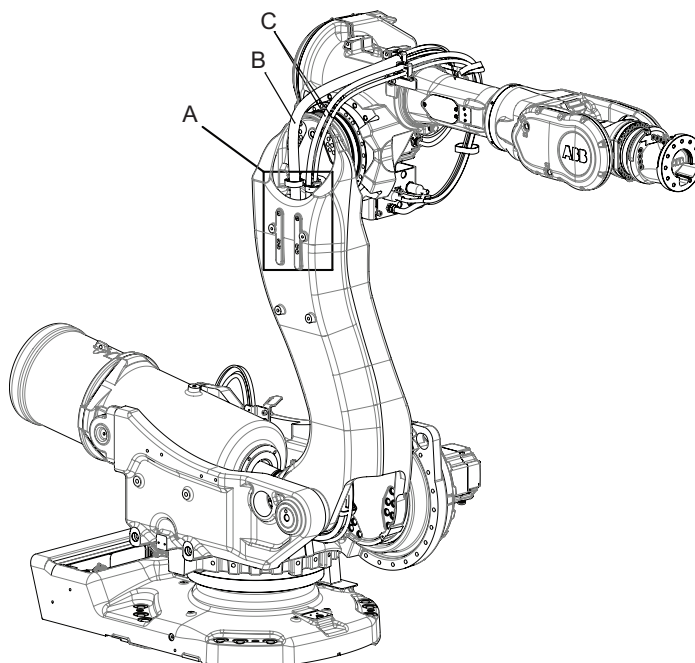

xx210000302

Continues on next page

4 Repair

4.3.1 Replacing cable harness, axes 1-6

Continued

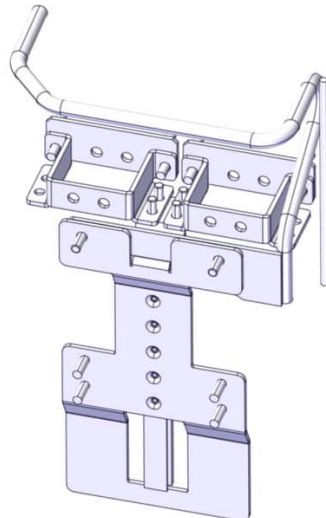
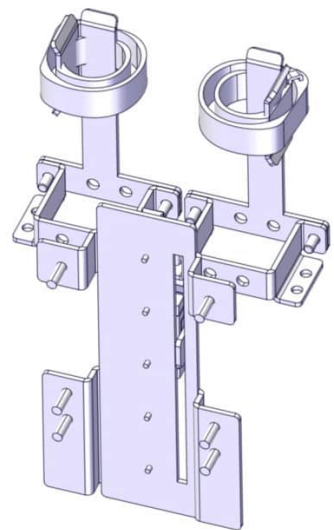
A	Linear guide (inside lower arm)	
	<p>Old version of linear guide</p>  <p>xx2100000305</p>	<p>New version of linear guide (kit article number: 3HAC077402-001)</p>  <p>xx2100000306</p>
B	Manipulator harness	
C	DressPack cable harness	

Cable brackets of the upper arm

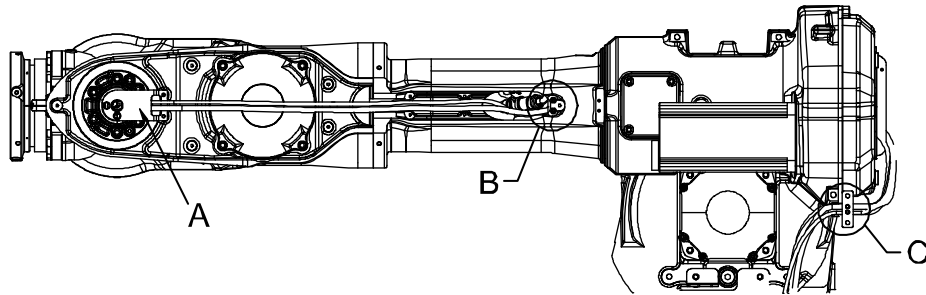



xx0500002293

A	Cable bracket, wrist unit
B	Cable bracket, upper arm tube
C	Cable attachment, rear

Continues on next page

Removing the cable harness - upper arm

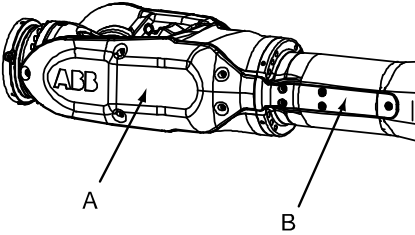
Use this procedure to remove the cable harness from the upper arm of the robot.

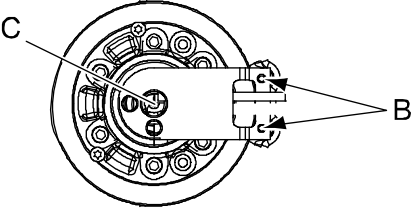
	Action	Note
1	In order to facilitate refitting of the cable harness, run the robot to the specified position: <ul style="list-style-type: none"> • Axis 1: 0 ° • Axis 2: 0 ° • Axis 3: 0 ° • Axis 4: 0 ° • Axis 5: +90 ° • Axis 6: no significance 	Axes 2 and 3 may be tilted slightly to improve access.
2	 DANGER Turn off all: <ul style="list-style-type: none"> • electric power supply to the robot • hydraulic pressure supply to the robot • air pressure supply to the robot Before entering the robot working area.	
3	Remove the <i>cover, wrist unit</i> and the <i>cover, upper arm tube</i> .	 <p>xx0200000214</p> <p>A Cover, wrist unit B Cover, upper arm tube</p>
4	 Note Axis 5 must be oriented in the correct position (+90°) to allow the motor 6 cover to open!	
5	Remove the cover of motor, axis 6 and disconnect all connectors beneath.	
6	Loosen the <i>cable bracket, wrist unit</i> by unscrewing its <i>attachment screws</i> . Two of the attachment screws are visibly located at the rear of the bracket and the third is located at the bottom of the cable bracket, in the center.	Shown in the figure Cable brackets of the upper arm on page 194 .  <p>xx0200000254</p> <ul style="list-style-type: none"> • B: Attachment screws, rear of cable bracket (2 pcs) • C: Attachment screw, bottom of cable bracket
7	Pick out the cabling from motor, axis 6.	

Continues on next page

4 Repair

4.3.1 Replacing cable harness, axes 1-6

Continued

	Action	Note
8	Loosen the <i>cable bracket, upper arm tube</i> by unscrewing the two screws on top of the tube.	Shown in the figure Cable brackets of the upper arm on page 194 .
9	Disconnect the two <i>connectors (R3.FB5 and R3.MP5)</i> inside the tube.	Shown in the figure Location of cable harness on page 192 .
10	Remove cable straps from the harness, if any.	
11	Remove the <i>cable attachment, rear</i> .	Shown in the figure Cable brackets of the upper arm on page 194 .
12	Remove the <i>covers</i> of motors axes 3 and 4 and disconnect all connectors beneath. Pick out the cabling from the motors.	
13	Gently pull the cable harness out from the upper arm tube.	
14	Tie the connectors into bundles, to avoid damaging them during further removal.	
15	Continue removing the cable harness in lower arm, frame and base.	

Removing the cable harness - frame and base

Use this procedure to remove the cable harness from the frame and base.

	Action	Note
1	Remove the <i>rear cover plate</i> from the robot by removing its attachment screws.	Shown in the figure Location of cable harness on page 192 .
2	Disconnect the <i>earth cable</i> beneath the rear cover plate.	
3	Disconnect connectors <i>R1.MP and R1.SMB</i> .	Shown in the figure Location of cable harness on page 192 .
4	Pull the cable and connectors up through the cable guide in the center of the frame.	
5	Disconnect all connectors at motors 1 and 2.	
6	Open the SMB cover carefully. The cable between the battery and the SMB-unit can stay connected, in order to avoid an update of the revolution counter. Be careful not to let the weight of the cover strain the cable!  Note In order to remove the cover completely, the connector R1.G must be disconnected! This causes a necessary updating of the revolution counter!	

Continues on next page

4.3.1 Replacing cable harness, axes 1-6

Continued

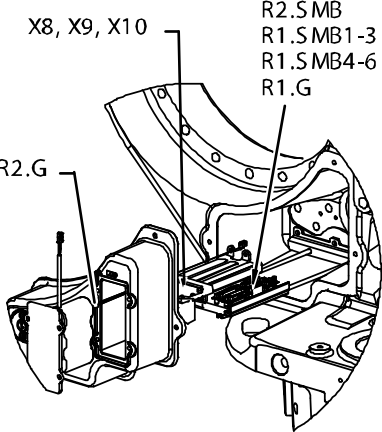
	Action	Note
7	<p>Disconnect connectors R2.SMB, R1.SMB1-3, R1.SMB4-6 from the SMB unit.</p> <p>Disconnect X8, X9 and X10 from the brake release unit.</p>	 <p>X8, X9, X10</p> <p>R2.SMB R1.SMB1-3 R1.SMB4-6 R1.G</p> <p>R2.G</p> <p>xx0200000118</p>

Continues on next page

4 Repair

4.3.1 Replacing cable harness, axes 1-6

Continued

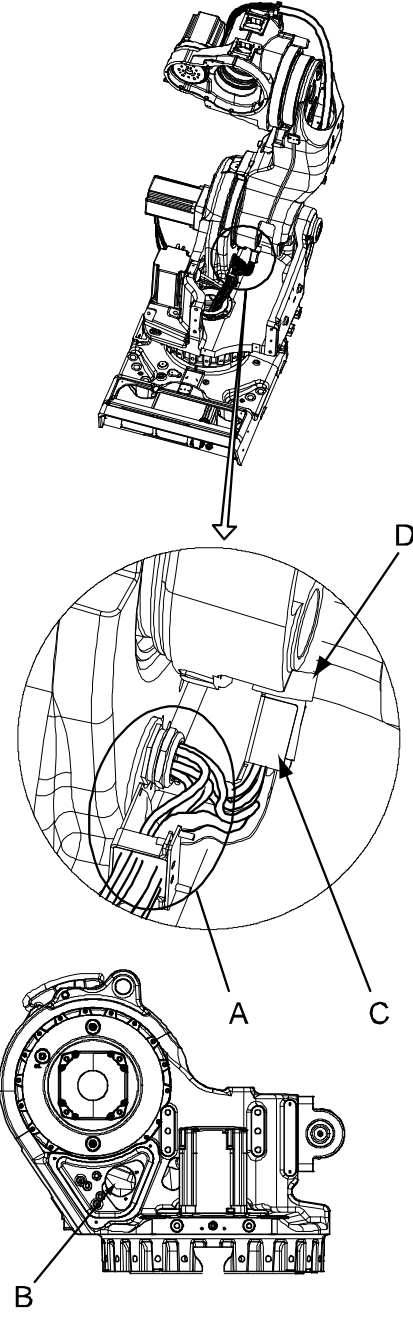
	Action	Note
8	<p>Remove</p> <ul style="list-style-type: none"> the <i>cable gland</i>, by removing the four <i>attachment screws</i> from inside the SMB recess the <i>attachment plate</i>, by removing the attachment screws and the <i>velcro strap</i>. <p> Note</p> <p>Different robot versions are fitted with different versions of the attachment plate. When replacing the cable harness, make sure the correct one is used to avoid cable failure.</p>	 <p>xx0300000560</p> <ul style="list-style-type: none"> A Cable gland B Attachment screws, cable gland C Attachment plate D Velcro strap
9	Remove the cable gland securing the cables inside the lower arm.	
10	Remove the velcro strap and cable gland.	

Continues on next page

Removing the cable harness - lower arm

Use this procedure to remove the cable harness from the lower arm.

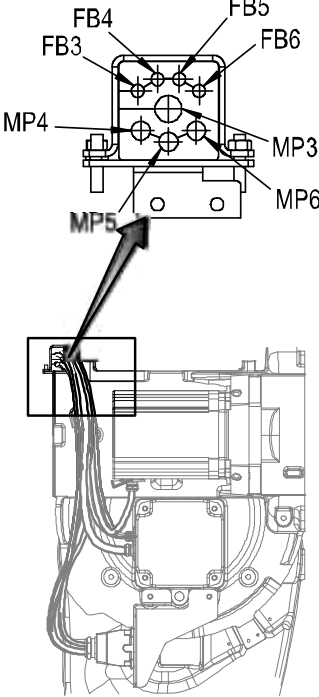
	Action	Note
1	Remove the cable gland that secures the cables to the arm house.	 <p>The diagram consists of two parts. The top part is a detailed view of a cable gland assembly with labels: FB3, FB4, FB5, FB6, MP3, MP4, and MP5. An arrow points from this detailed view to a larger perspective drawing of the lower arm assembly, where the gland is shown mounted on the arm house. The reference code 'xx010000143' is located at the bottom of the diagram.</p>
2	Remove the <i>velcro strap</i> from the harness at the cable fixing bracket at the arm house and at the lower arm.	Shown in the figure Location of cable harness on page 192 .
3	Disconnect all connectors at the axis-3 and axis-4 motors.	
4	Gently pull the cable harness out.	

Refitting the cable harness - lower arm, frame and base

Use this procedure to refit the cable harness on the lower arm, frame and base of the robot.

How to refit on the upper arm is described in section [Refitting the cable harness - upper arm on page 204](#).

	Action	Note
1	Push the cable and connectors down through the cable guide in the center of the frame. <ul style="list-style-type: none"> • Make sure the cables are not twisted with each other or with customer harnesses if any • Make a note of the correct positions of the connectors. 	Shown in the figure Location of cable harness on page 192 .
2	Reconnect connectors <i>R1.MP</i> and <i>R1.SMB</i> at the base.	Tightening torque for R1.SMB: 10 Nm. Shown in the figure Location of cable harness on page 192 . Make a note of the correct positions of the connectors!

Continues on next page

4 Repair

4.3.1 Replacing cable harness, axes 1-6

Continued

	Action	Note
3	Reconnect the <i>earth cable</i> .	
4	Refit the <i>rear cover plate</i> to the robot with its attachment screws.	Shown in the figure Location of cable harness on page 192 .
5	Reconnect all connectors at motors axes 1 and 2.	

Continues on next page

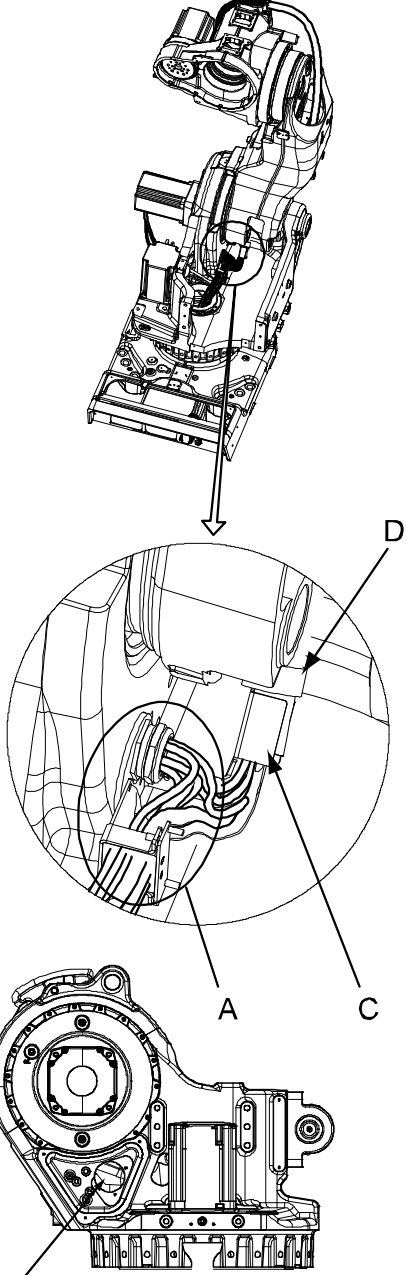

	Action	Note
6	<p>Secure the <i>cable gland</i> with four <i>attachment screws</i> from inside the SMB recess.</p> <p>Secure the correct <i>attachment plate</i> to the cable gland with its two attachment screws, using locking liquid.</p> <p>Refit the <i>velcro strap</i>. Shown in the figure Location of cable harness on page 192.</p> <p> Note</p> <p>Different robot versions are fitted with different versions of the attachment plate. Make sure the correct one is used to avoid cable failure.</p>	<p>Locking liquid is specified in Required equipment on page 193.</p>  <p>xx0300000560</p> <ul style="list-style-type: none"> A Cable gland B Attachment screws, cable gland C Attachment plate D Velcro strap

Continues on next page

4 Repair

4.3.1 Replacing cable harness, axes 1-6

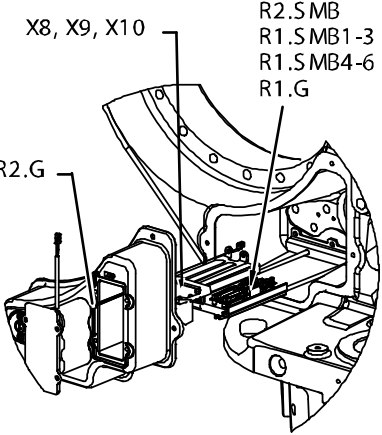
Continued

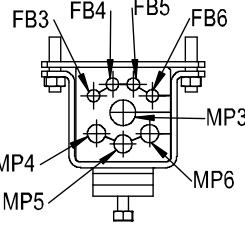
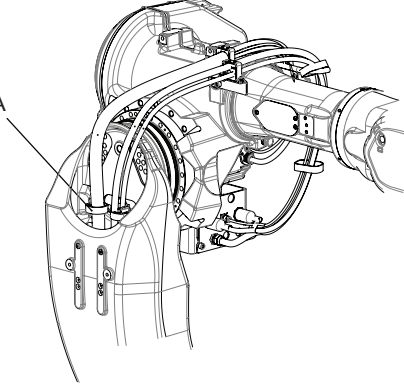
	Action	Note
7	<p>Reconnect connectors to the SMB unit:</p> <ul style="list-style-type: none"> • R2.SMB • R1.SMB1-3 • R1.SMB4-6 <p>Reconnect connectors to the Brake release unit:</p> <ul style="list-style-type: none"> • X8 • X9 • X10 <p>Reconnect R1.G if it has been disconnected.</p>	 <p>xx0200000118</p>
8	<p>Secure the SMB cover with its attachment screws.</p> <p>If cabling is used for 7th axis (option), refit the connector R2.FB7 to the SMB cover and tighten with 6 Nm.</p>	
9	<p> WARNING</p> <p>Before continuing any service work, please observe the safety information in section The brake release buttons may be jammed after service work on page 191!</p>	
10	<p>Push the cable harness gently through the lower arm.</p>	
11	<p>Refit the <i>cable gland</i> securing the cables inside the lower arm.</p>	 <p>xx0100000142</p>
12	<p>Refit the <i>velcro strap</i>. (Bracket is not available on all robots.)</p>	 <p>xx2000001527</p> <p>A Velcro strap</p>

Continues on next page

4.3.1 Replacing cable harness, axes 1-6
Continued

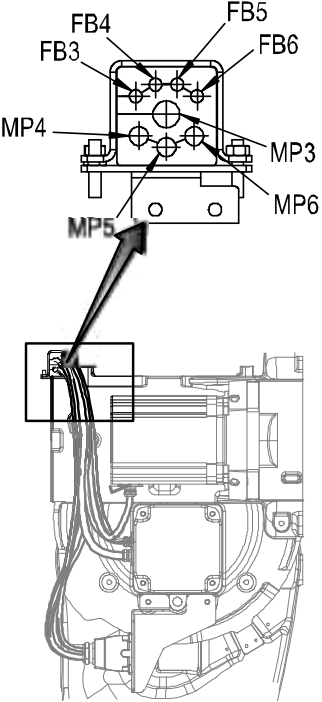
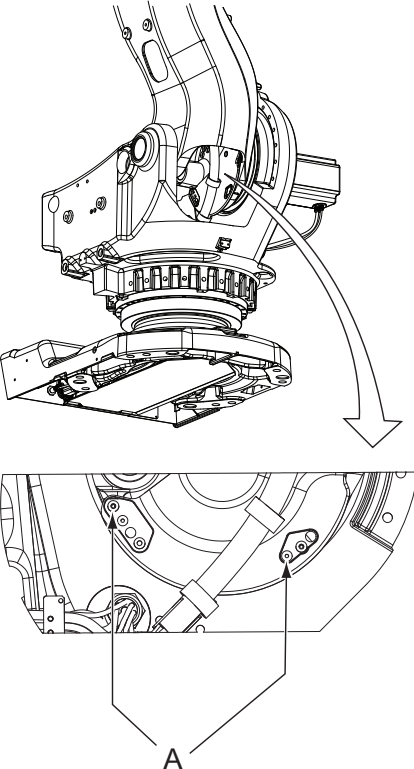
	Action	Note
13	<p>Refit the cable gland securing the cables to the arm house.</p> <p> Note</p> <p>The cable harness is delivered in a pretwisted state. Make sure not to affect this by twisting the cable harness further in any direction.</p>	 <p>xx0100000143</p>
14	<p>Fit a cable protection to the lower arm, if not already mounted, with two <i>securing screws</i>, M6x16.</p>	 <p>xx0500002320</p> <p>Parts:</p> <ul style="list-style-type: none"> A: Securing screws, M6x16 (2 pcs)

Continues on next page

4 Repair

4.3.1 Replacing cable harness, axes 1-6

Continued

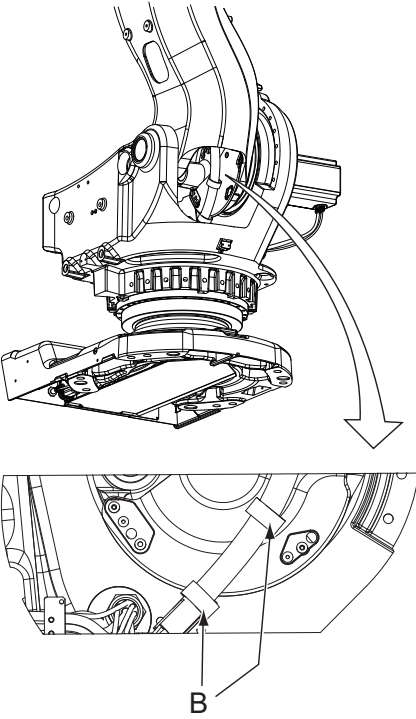
	Action	Note
15	Secure the cable harness with two velcro straps (B), with a distance of approximately 180 mm. Fix the strap by wrapping it two turns around the largest cable before wrapping around the complete harness.	 <p>xx1900001418</p>



Refitting the cable harness - upper arm

Use this procedure to refit the cable harness on the upper arm of the robot.

How to refit the cable harness on lower arm, frame and base is described in section [Refitting the cable harness - lower arm, frame and base on page 199](#).

	Action	Note
1	Before refitting the upper end of the cable harness, the lower end must first be refitted.	How to refit see section Refitting the cable harness - lower arm, frame and base on page 199 .

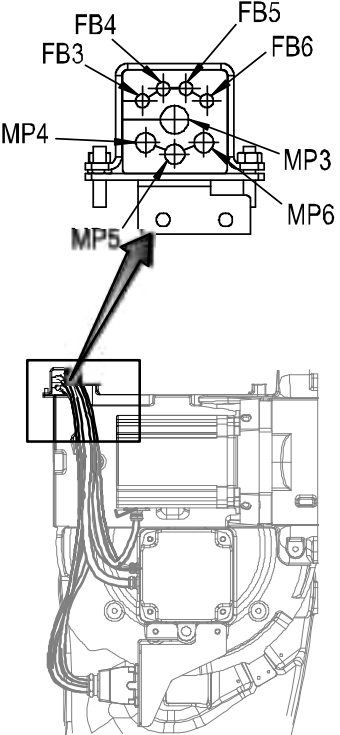
Continues on next page



	Action	Note
2	<p>Refit the <i>cable gland</i> securing the cables in the armhouse.</p> <p> Note</p> <p>The cable harness is delivered pretwisted. Make sure not to affect this by twisting the cable harness further in any direction.</p>	 <p>xx0100000143</p>
3	<p>Reconnect all connectors on motors axes 3 and 4.</p>	
4	<p>Secure the cable harness to the upper armhouse by refitting the <i>velcro strap</i> to the cable bracket at the upper armhouse.</p> <p>Refit the <i>velcro strap</i> at the guide plate axis 2.</p>	<p>Shown in the figure Location of cable harness on page 192.</p>
5	<p>Gently insert the cable harness from the rear into the upper arm.</p>	
6	<p>Connect the two connectors inside the upper arm tube, R2.FB5 and R3.MP5 and secure the <i>cable bracket</i> with its two attachment screws to the tube.</p>	<p>Shown in the figure Cable brackets of the upper arm on page 194.</p>
7	<p> Note</p> <p>The position of axis 6 must be +90° for a correct installation of the cable harness.</p>	

Continues on next page

4 Repair

4.3.1 Replacing cable harness, axes 1-6

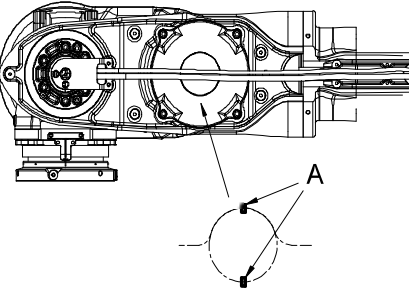
Continued

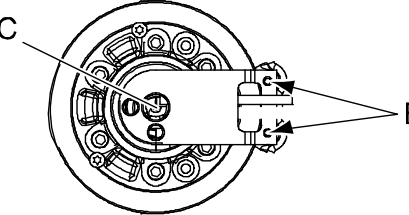
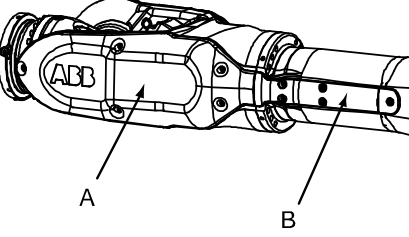
	Action	Note
8	<p>Place the cabling to motor axis 6 correctly on the upper arm and gently pull the connectors through the hole on top of the wrist unit to motor axis 6.</p> <p>In case of excess of cable length:</p> <ul style="list-style-type: none"> put the excess cable in a loop in the area shown in the figure and secure with cable straps. Cables are longer in order to fit different upper arm lengths. 	 <p>xx0200000185</p> <ul style="list-style-type: none"> A: Cable straps
9	<p>Fasten the cable bracket, wrist unit with its <i>attachment screws</i>. Two screws are visible at the <i>rear attachment point</i> of the bracket and the third is located at the <i>bottom of the cable bracket</i>, in the center.</p> <p> Note</p> <p>Do not use stainless attachment screws! There is a potential risk of galvanic corrosion.</p>	 <p>xx0200000254</p> <ul style="list-style-type: none"> B: Attachment screws, rear attachment point of cable bracket (2 pcs) C: Attachment screw, bottom of cable bracket (1 pc)
10	<p>Reconnect the connectors to motor, axis 6 and refit the motor cover.</p>	<p>Foundry robots: It is recommended to use a new gasket on cover.</p>
11	<p>Refit the cover, upper arm tube and the cover, wrist unit.</p> <p>Make sure the cabling is placed correctly when refitting the covers, and does not get jammed.</p>	 <p>xx0200000214</p> <p>Parts:</p> <ul style="list-style-type: none"> A: Cover, wrist unit. Tightening torque: 14 Nm. Add Loctite to screw before fastening. Screw 3HAB3409-25, Washer 3HAC062379-001 B: Cover, upper arm tube
12	<p>If any cable straps have been removed, refit them to the harness.</p>	
13	<p>Refit the <i>cable attachment, rear</i>.</p>	<p>Shown in the figure Cable brackets of the upper arm on page 194.</p>
14	<p>Make an overall inspection of the installed cable harness.</p>	<p>See Inspecting the cable harness on page 138.</p>
15	<p>If the connection between the SMB battery and the SMB unit has been broken, the revolution counters now must be updated!</p>	<p>Detailed in section Updating revolution counters on IRC5 robots on page 366.</p>

Continues on next page

	Action	Note
16	 DANGER Make sure all safety requirements are met when performing the first test run. See Test run after installation, maintenance, or repair on page 108 .	

4 Repair

4.3.2 Replacement of cable harness, axes 1-4

4.3.2 Replacement of cable harness, axes 1-4

General

This section details how to replace the cable harness that runs from axis 1 to axis 4. If the robot is equipped with an undivided cable harness, it is instead replaced as detailed in section [Replacing cable harness, axes 1-6 on page 192](#).

(The divided cable for axes 1-4 is not applicable for robot model IRB 6650S - 90/3.9.)

Location of cable harness

The cable harness for axes 1-4 is run throughout the base, frame and lower arm as shown in the figure below.

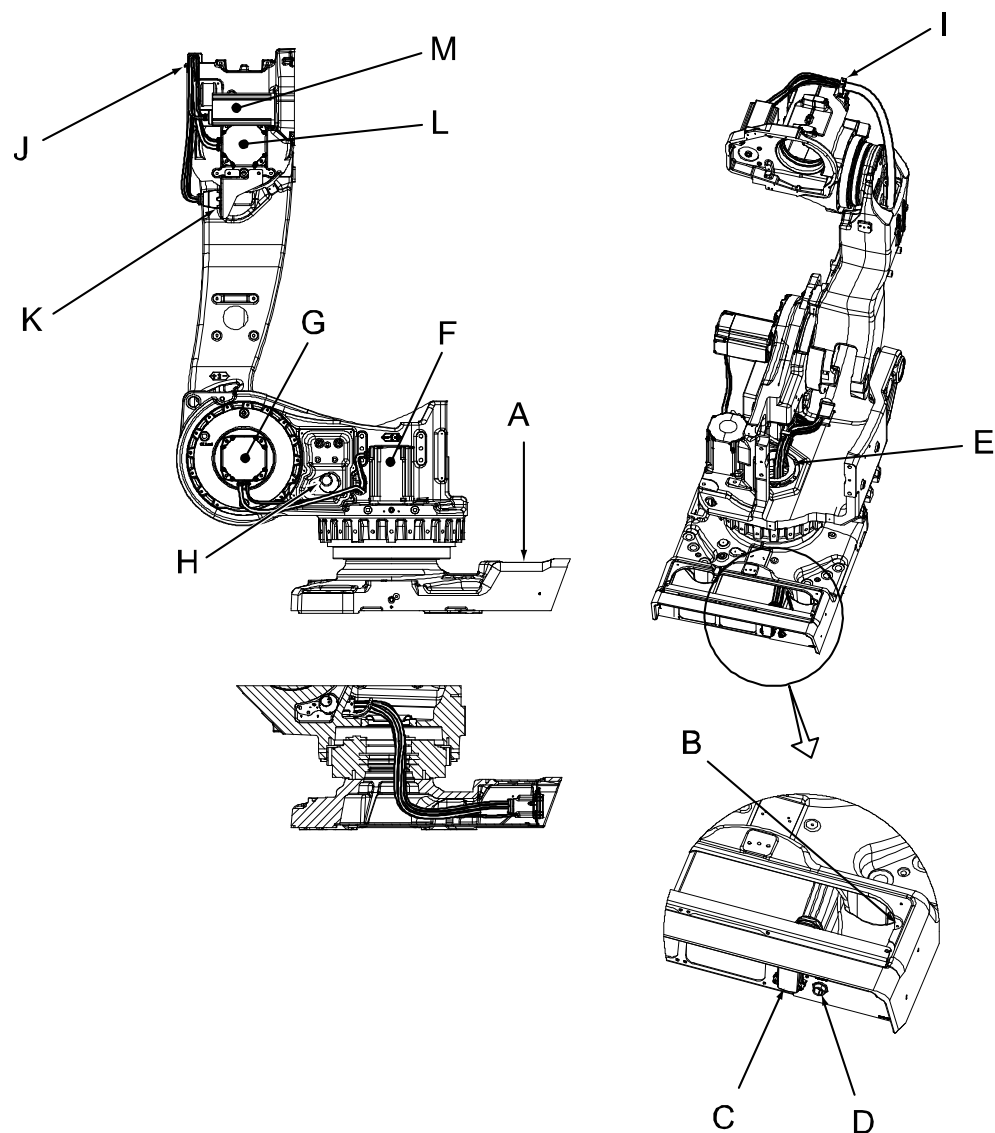

xx0300000589

A	Rear cover plate
B	Attachment point for earth lug

Continues on next page

C	Connector R1.MP
D	Connector R1.SMB
E	Cable guide in the center of the frame
F	Connectors at motor 1: R2.FB1 and R2.MP1
G	Connectors at motor 2: R2.FB2 and R2.MP2
H	SMB recess
I	Cable gland, upper arm house
J	Cable fixing bracket + velcro strap
K	Connector R2.M5/6 at the cable division point
L	Connectors at motor 3: R2.FB3 and R2.MP3 (optional signal lamp: R2.H1 and R2.H2)
M	Connectors at motor 4: R2.FB4 and R2.MP4

Required equipment

Equipment, etc.	Spare part no.	Art. no.	Note
Cable harness axes 1-4	3HAC033389-001		
Locking liquid			Loctite 243 Used to secure the attachment screws for the attachment plate inside the frame.
Standard toolkit		-	Content is defined in section Standard tools on page 406 .
Other tools and procedures may be required. See references to these procedures in the step-by-step instructions below.			These procedures include references to the tools required.
Circuit diagram			See chapter Circuit diagram on page 411 .

Removal, cable harness, axes 1-4

The procedure below details how to remove the cable harness, axes 1-4.

	Action	Note
1	In order to facilitate refitting of cable harness, run the robot to the specified position: <ul style="list-style-type: none"> • Axis 1: 0 ° • Axis 2: 0 ° • Axis 3: 0 ° • Axis 4: 0 ° • Axis 5: +90 ° • Axis 6: no significance 	Axes 2 and 3 may be tilted slightly to improve access.

Continues on next page

4 Repair

4.3.2 Replacement of cable harness, axes 1-4

Continued

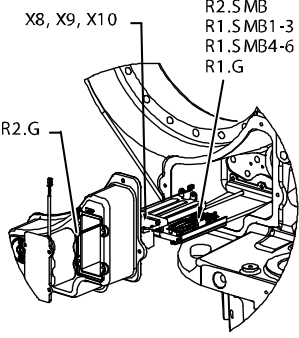
	Action	Note
2	 DANGER Turn off all: <ul style="list-style-type: none"> • electric power supply to the robot • hydraulic pressure supply to the robot • air pressure supply to the robot Before entering the robot working area.	
3	Remove the <i>rear cover plate</i> from the robot by removing its attachment screws.	Shown in the figure Location of cable harness on page 208 .
4	Disconnect the <i>earth cable</i> .	Attachment point is shown in the figure Location of cable harness on page 208 !
5	Disconnect connectors <i>R1.MP and R1.SMB</i> .	Attachment points are shown in the figure Location of cable harness on page 208 .
6	Pull the cable and connectors up through the cable guide in the center of the frame.	
7	Disconnect all connectors at motors 1 and 2.	Specified and shown in the figure Location of cable harness on page 208 !
8	Open the SMB cover carefully. The cable between the battery and the SMB-unit may stay connected, in order to avoid an update of the revolution counter. Be careful not to let the weight of the cover strain the cable! In order to remove the cover completely, the connector R1.G must be disconnected! This causes a necessary updating of the revolution counter!	
9	Disconnect connectors R2.SMB, R1.SMB1-3, R1.SMB4-6 from the SMB unit. Disconnect X8, X9 and X10 from the brake release unit.	 <p>xx0200000118</p>

Continues on next page

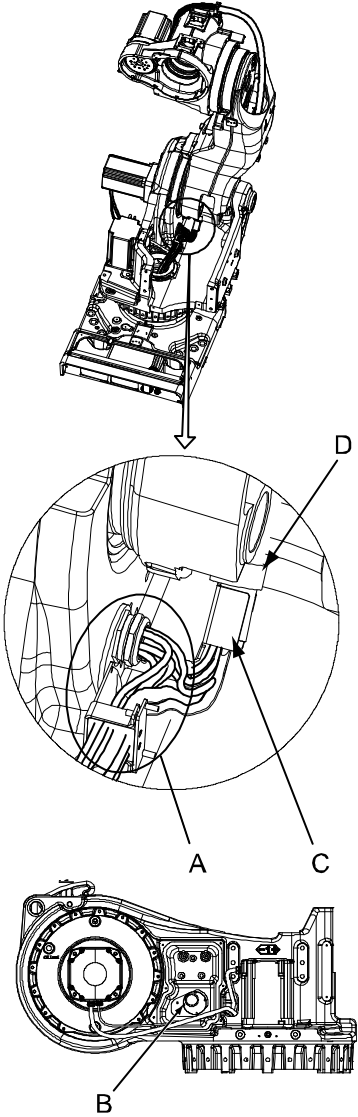
	Action	Note
10	<p>Remove</p> <ul style="list-style-type: none"> the <i>cable gland</i> (A), by removing the four attachment screws from inside the SMB recess (B) the <i>attachment plate</i> (C), by removing the attachment screws and the velcro strap (D). <p> Note</p> <p>Different robot versions are fitted with different versions of the attachment plate. When replacing the cable harness, make sure the correct one is used to avoid cable failure.</p>	 <p>xx0400001069</p> <ul style="list-style-type: none"> A: Cable gland B: Attachment screws, cable gland C: Attachment plate D: Velcro strap
11	Remove the cable gland securing the cables inside the lower arm.	

Continues on next page

4 Repair

4.3.2 Replacement of cable harness, axes 1-4

Continued

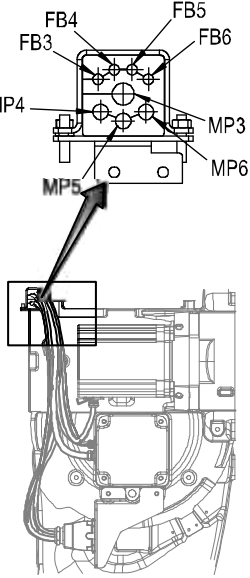
	Action	Note
12	Remove the cable gland securing the cables to the arm house.	 <p>xx0100000143</p>
13	Remove the <i>velcro strap</i> from the harness at the cable fixing bracket at the arm house.	Shown in the figure Location of cable harness on page 208 .
14	Disconnect <i>connector R2.M5/6</i> at the cable division point.	Shown in the figure Location of cable harness on page 208 !
15	Disconnect all connectors at motor 3 and motor 4.	Specified and shown in the figure Location of cable harness on page 208 !
16	Gently pull the cable harness out.	

Refitting, cable harness, axes 1-4

The procedure below details how to refit the cable harness, axes 1-4.

	Action	Note
1	 <p>DANGER</p> <p>Turn off all:</p> <ul style="list-style-type: none"> • electric power supply to the robot • hydraulic pressure supply to the robot • air pressure supply to the robot <p>Before entering the robot working area.</p>	
2	<p>In order to facilitate refitting of cable harness, move the robot to the specified position:</p> <ul style="list-style-type: none"> • Axis 1: 0 degrees • Axis 2: 0 degrees • Axis 3: 0 degrees • Axis 4: 0 degrees • Axis 5: +90 degrees • Axis 6: no significance 	Axes 2 and 3 may be tilted slightly to improve access.

Continues on next page

	Action	Note
3	Pull the cable and connectors down through the cable guide in the center of the frame.	Make sure the cables are not twisted with each other or with eventual customer harnesses! Make a note of the correct positions of the connectors!
4	Reconnect connectors <i>R1.MP</i> and <i>R1.SMB</i> at the rear cover plate.	Tightening torque for R1.SMB: 10 Nm. Make a note of the correct positions of the connectors! Attachment point is shown in the figure Location of cable harness on page 208 .
5	Reconnect the earth cable.	Attachment point is shown in the figure Location of cable harness on page 208 !
6	Refit the <i>rear cover plate</i> to the robot with its attachment screws.	Shown in the figure Location of cable harness on page 208 .
7	Reconnect all connectors at motors 1 and 2.	Specified and shown in the figure Location of cable harness on page 208 !

Continues on next page

4 Repair

4.3.2 Replacement of cable harness, axes 1-4

Continued

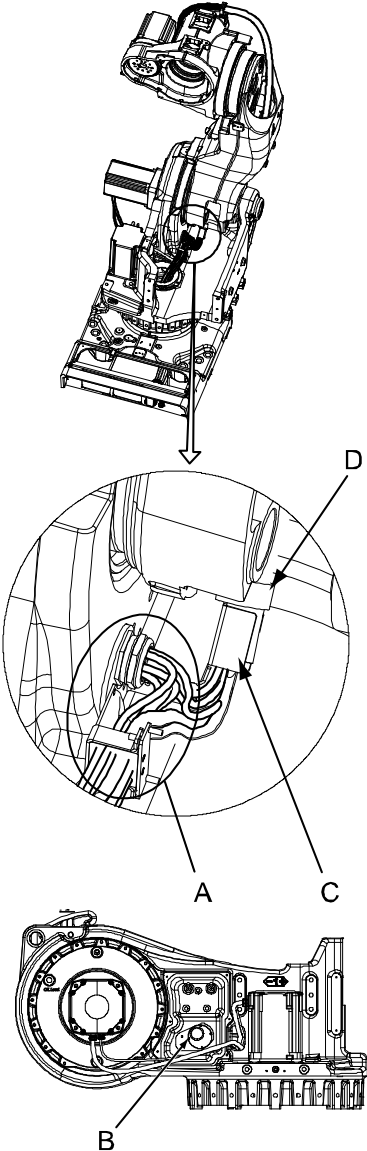
	Action	Note
8	<p>Secure the cable gland (A) with four attachment screws (B) from inside the SMB recess.</p> <p>Secure the correct attachment plate (C) to the cable gland with its two attachment screws, using locking liquid.</p> <p>Refit the velcro strap (D).</p> <p> Note</p> <p>Different robot versions are fitted with different versions of the attachment plate. Make sure the correct one is used to avoid cable failure.</p>	<p>Locking liquid is specified in Required equipment on page 209.</p>  <p>xx0400001069</p> <ul style="list-style-type: none"> • A: Cable gland • B: Attachment screws, cable gland • C: Attachment plate • D: Velcro strap
9	<p>Reconnect connectors R2.SMB, R1.SMB1-3, R1.SMB4-6 to the SMB unit.</p> <p>Reconnect X8, X9 and X10 to the brake release unit.</p> <p>Reconnect R1.G if it has been disconnected.</p>	
10	<p>Secure the SMB cover with its attachment screws.</p> <p>If cabling is used for 7th axis (option), refit the connector R2.FB7 to the SMB cover and tighten with 6 Nm.</p>	

Continues on next page

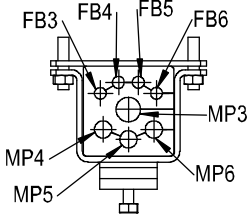
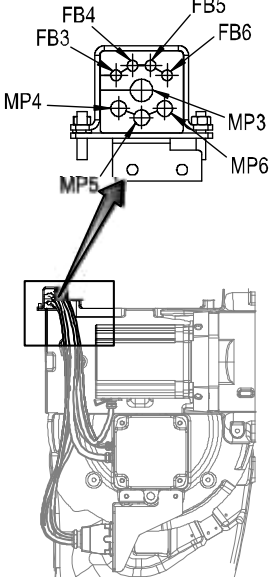
	Action	Note
11	 WARNING Before continuing any service work, please observe the safety information in section The brake release buttons may be jammed after service work on page 191!	
12	Pull the cable harness through the lower arm.	
13	Refit the cable gland securing the cables inside the lower arm.	 <p>xx0100000142</p>
14	Refit the cable gland securing the cables to the arm house. Make sure not to twist the harness!	 <p>xx0100000143</p>
15	Reconnect all connectors at motor 3 and motor 4.	Specified and shown in the figure Location of cable harness on page 208!
16	Reconnect the <i>connector R2.M5/6</i> gently at the cable division point. Be careful not to bend the attachment plate when fastening the screws!	Shown in the figure Location of cable harness on page 208! M6, 2 pcs.
17	Secure the cable harness to the upper arm house by refitting the <i>velcro strap</i> to the cable bracket at the upper arm house.	Shown in the figure Location of cable harness on page 208!

Continues on next page

4 Repair

4.3.2 Replacement of cable harness, axes 1-4

Continued

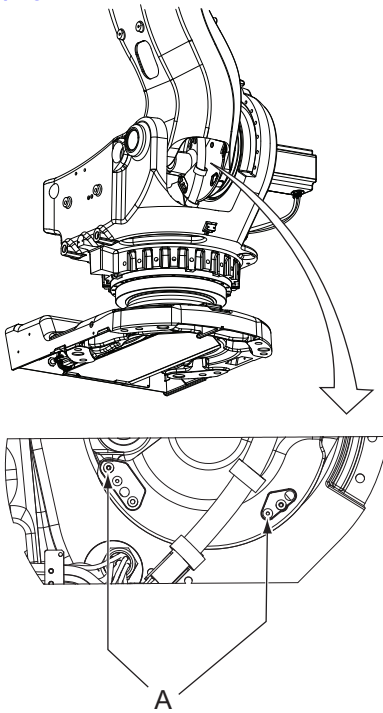
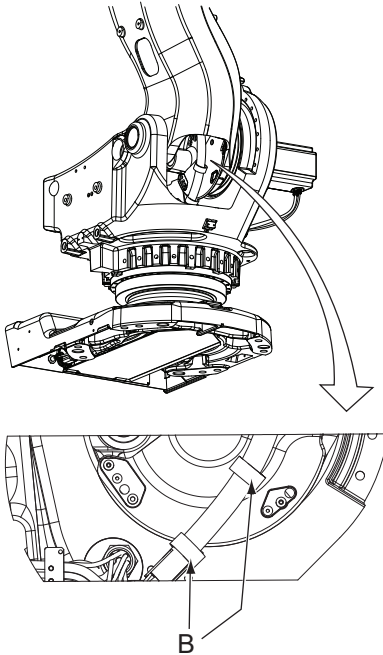
	Action	Note
18	Fit a cable protection to the lower arm, if not already mounted, with two securing screws (A), M6x16.	<p>Both the protection and the strap are included in the spare part no., specified in Required equipment on page 209.</p>  <p style="text-align: center;">A</p> <p>xx0500002320</p>
19	Secure the cable harness with two velcro straps (B), with a distance of approximately 180 mm. Fix the strap by wrapping it two turns around the largest cable before wrapping around the complete harness.	 <p style="text-align: center;">B</p> <p>xx1900001418</p>
20	Refit the cable harness to the <i>guide plate axis 2</i> .	Shown in the figure Location of cable harness on page 208 .

Continues on next page

	Action	Note
21	Refit the <i>velcro strap</i> at the guide plate axis 2.	Shown in the figure Location of cable harness on page 208 .
22	Make an overall inspection of the installed cable harness.	See Inspecting the cable harness on page 138 .
23	If the connection between the SMB battery and the SMB unit has been broken, the revolution counters must now be updated!	Detailed in the Calibration chapter - section Updating revolution counters on IRC5 robots on page 366 .
24	 DANGER Make sure all safety requirements are met when performing the first test run. See Test run after installation, maintenance, or repair on page 108 .	

4 Repair

4.3.3 Replacement of cable harness, axes 5-6

4.3.3 Replacement of cable harness, axes 5-6

General

This cable is not applicable for robot model IRB 6650S - 90/3.9.

Location of cable harness ax 5-6

The location of the cable harness, axes 5-6, is shown in the figure below.

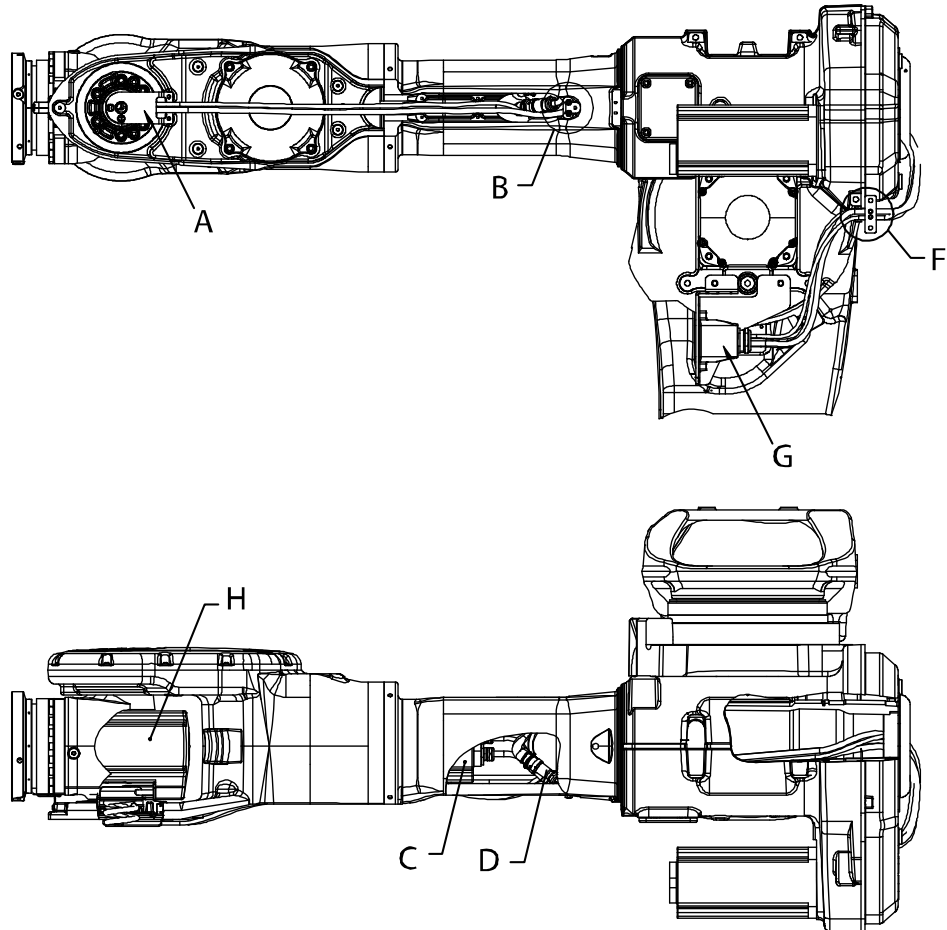

xx0200000213

A	Cable bracket, wrist unit
B	Cable bracket, upper arm tube
C	Connectors at motor axis 5; R4.FB5 and R4.MP5
D	Connectors in upper arm tube; R3.FB5 and R3.MP5
F	Cable attachment, rear
G	Connector at cable harness division point; R2.M5/6
H	Connectors at motor, axis 6; R3.FB6 and R3.MP6

Continues on next page



Required equipment

Equipment, etc.	Spare part no.	Note
Cable harness axes 5-6	3HAC14140-1	Not applicable for IRB 6650S - 90/3.9.
Standard toolkit	-	Content is defined in section Standard tools on page 406 .
Other tools and procedures may be required. See references to these procedures in the step-by-step instructions below.		These procedures include references to the tools required.
Circuit diagram		See chapter Circuit diagram on page 411 .

Removal, cable harness, axes 5-6

The procedure below details how to remove the upper cable harness.

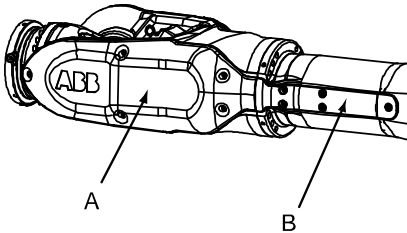
The separate cable that goes from the connection point inside of the upper arm tube to the motor, axis 5, is not included in this procedure. The removal of that cable is described in section [Removal, cabling axis 5 motor on page 223](#).

	Action	Note/Illustration
1	 DANGER Turn off all: <ul style="list-style-type: none"> • electric power supply to the robot • hydraulic pressure supply to the robot • air pressure supply to the robot Before entering the robot working area.	
2	Remove the cover, wrist unit and the cover, upper arm tube.	 <p>xx0200000214</p> <ul style="list-style-type: none"> • A: cover, wrist unit • B: cover, upper arm tube
3	 Note Axis 5 must be oriented in the correct position (+90°) to allow the motor 6 cover to open!	
4	Remove the cover of motor, axis 6 and disconnect all connectors beneath.	Specified in the figure Location of cable harness ax 5-6 on page 218 .

Continues on next page

4 Repair

4.3.3 Replacement of cable harness, axes 5-6

Continued

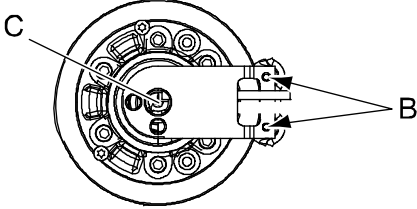
	Action	Note/Illustration
5	Loosen the <i>cable bracket</i> on top of the wrist unit by undoing the three attachment screws. Two of the attachment screws are visibly located at the rear attachment and the third is located at the bottom of the cable bracket, in the center.	Shown in the figure Location of cable harness ax 5-6 on page 218 .  <p>xx0200000254</p> <ul style="list-style-type: none"> • B: Attachment screws, rear of cable bracket, 2 pcs • C: Attachment screw, bottom of cable bracket, 1 pc
6	Pick out the cabling from motor, axis 6.	
7	Loosen the <i>cable bracket in the upper arm tube</i> by undoing the two screws on top of the tube.	Shown in the figure Location of cable harness ax 5-6 on page 218 .
8	Disconnect the two <i>connectors (R3.FB5 and R3.MP5)</i> in the tube.	Shown in the figure Location of cable harness ax 5-6 on page 218 .
9	Remove eventual cable straps from the harness.	
10	Remove the <i>cable attachment, rear</i> .	Shown in the figure Location of cable harness ax 5-6 on page 218 .
11	Disconnect connector <i>R2.M5/6</i> at the cable harness division point.	Shown in the figure Location of cable harness ax 5-6 on page 218 .
12	Gently pull the cable harness out.	

Refitting, cable harness, axes 5-6

The procedure below details how to refit the upper arm cable harness. The separate cable that goes from the connection point inside of the upper arm tube to the motor, axis 5, is not included in this procedure. The refitting of that cable is described further down in section [Refitting, cabling axis 5 motor on page 224](#).

	Action	Note/Illustration
1	Position the upper arm as follows: <ul style="list-style-type: none"> • Axis 4: 0 degrees • Axis 5: +90 degrees • Axis 6: no significance 	
2	Gently insert the cable harness from the rear into the upper arm.	
3	Connect the two <i>connectors inside the upper arm tube, R3.FB5 and R3.MP5</i> and secure the <i>cable bracket</i> with the two attachment screws to the tube.	Shown in the figure Location of cable harness ax 5-6 on page 218 .

Continues on next page

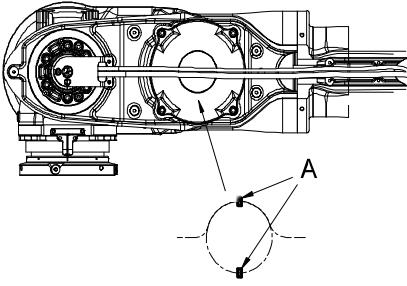
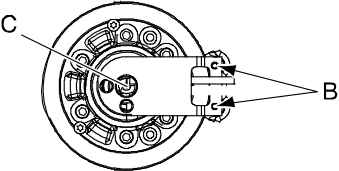
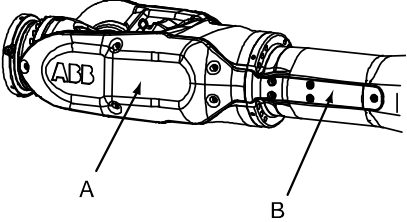
	Action	Note/Illustration
4	Place the cabling to motor, axis 6, correctly on the upper arm and gently pull the connectors through the hole on top of wrist unit to motor, axis 6.	 <p>xx0200000185</p> <ul style="list-style-type: none"> In case of excess cable length: put a loop of cable in this area with cable straps (A). The cables are longer in order to fit different upper arm lengths.
5	Fasten the <i>cable bracket, wrist unit</i> with three attachment screws, two of them visible at the rear attachment point and the third located on the bottom of the cable bracket, in the center.	<p>Also shown in the figure Location of cable harness ax 5-6 on page 218.</p>  <p>xx0200000254</p> <ul style="list-style-type: none"> B: Attachment screws, rear of cable bracket. C: Attachment screw, bottom of cable bracket.
6	Reconnect the connectors to motor, axis 6 and refit the motor cover.	
7	Refit the cover, upper arm and the cover, wrist unit. Make sure the cabling is placed correctly when refitting the covers, and does not get jammed.	 <p>xx0200000214</p> <ul style="list-style-type: none"> A: Cover, wrist unit. Tightening torque: 14 Nm. Add Loctite to screw before fastening. Screw 3HAB3409-25, Washer 3HAC062379-001 B: cover, upper arm tube
8	If any cable straps have been removed, refit them to the harness.	
9	Refit the <i>cable attachment, rear</i> .	Shown in the figure Location of cable harness ax 5-6 on page 218 .
10	Reconnect connector <i>R2.M5/6</i> gently at the rear cable division point with two screws, M6. Be careful not to bend the attachment plate when fastening the screws!	Shown in the figure Location of cable harness ax 5-6 on page 218 .

Continues on next page

4 Repair

4.3.3 Replacement of cable harness, axes 5-6

Continued

	Action	Note/Illustration
11	Make an overall inspection of the installed cable harness.	See <i>Inspecting the cable harness on page 138</i> .
12	Update the revolution counter!	Detailed in section <i>Updating revolution counters on IRC5 robots on page 366</i> .

4.3.4 Replacement of cabling, axis 5 motor

Location of cabling

The separate cables for the axis 5 motor are located inside the upper arm tube, as shown in the figure below.

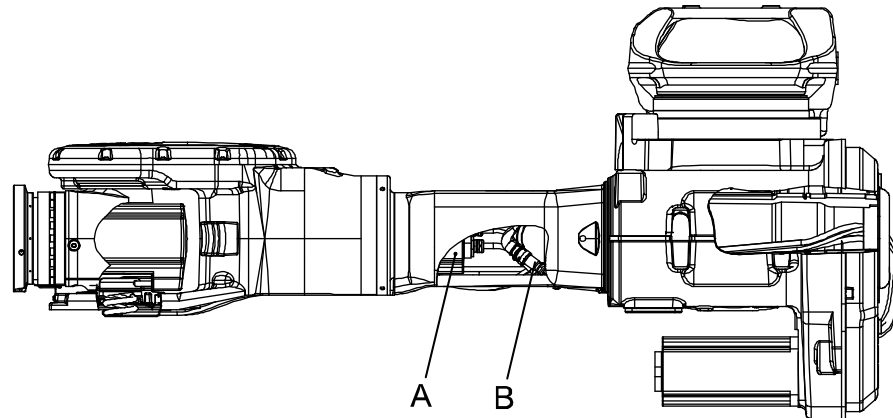

xx0500002294

A	Motor axis 5 with connectors R4.FB5 and R4.MP5
B	Connectors R3.FB5 and R3.MP5

Required equipment

Equipment	Spare part no.	Note
Cable harness axis 5	See Spare part lists on page 397 .	
Circuit diagram	3HAC025744-001	
Standard toolkit		Content is defined in section Standard tools on page 406 .
Other tools and procedures may be required. See references to these procedures in the step-by-step instructions below.		These procedures include references to the tools required.

Removal, cabling axis 5 motor

The procedure below details how to remove the cabling from the axis 5 motor.

	Action	Note
1	 DANGER Turn off all: <ul style="list-style-type: none"> • electric power supply to the robot • hydraulic pressure supply to the robot • air pressure supply to the robot Before entering the robot working area.	
2	Remove the complete wrist unit.	Detailed in section: <ul style="list-style-type: none"> • Removal, wrist unit on page 237.

Continues on next page

4 Repair



4.3.4 Replacement of cabling, axis 5 motor

Continued

	Action	Note
3	Remove the cover of motor, axis 5.	
4	Disconnect all connectors at motor, axis 5.	
5	Remove the cable gland cover at the cable exit by unscrewing its two attachment screws.	
6	Remove the cable, axis 5.	

Refitting, cabling axis 5 motor

The procedure below details how to refit the cabling to the motor of axis 5.

	Action	Note
1	 DANGER Turn off all: <ul style="list-style-type: none">• electric power supply to the robot• hydraulic pressure supply to the robot• air pressure supply to the robot Before entering the robot working area.	
2	Reconnect all connectors at motor, axis 5.	
3	Refit the cable gland cover at the cable exit with its two attachment screws.	
4	Refit the cover of motor, axis 5.	
5	Refit the complete wrist unit.	Detailed in section: <ul style="list-style-type: none">• Refitting, wrist unit on page 238.
6	Re-calibrate the robot.	Calibration is detailed in a separate calibration manual enclosed with the calibration tools. General calibration information is included in section Calibration on page 359.
7	 DANGER Make sure all safety requirements are met when performing the first test run. See Test run after installation, maintenance, or repair on page 108.	

4.3.5 Replacement of complete arm system

Location of arm system

The complete arm system is defined as the complete robot except for the base and axis-1 gearbox. This is shown in the figure below.

A more detailed view of the component and its position may be found in [Spare part lists on page 397](#).

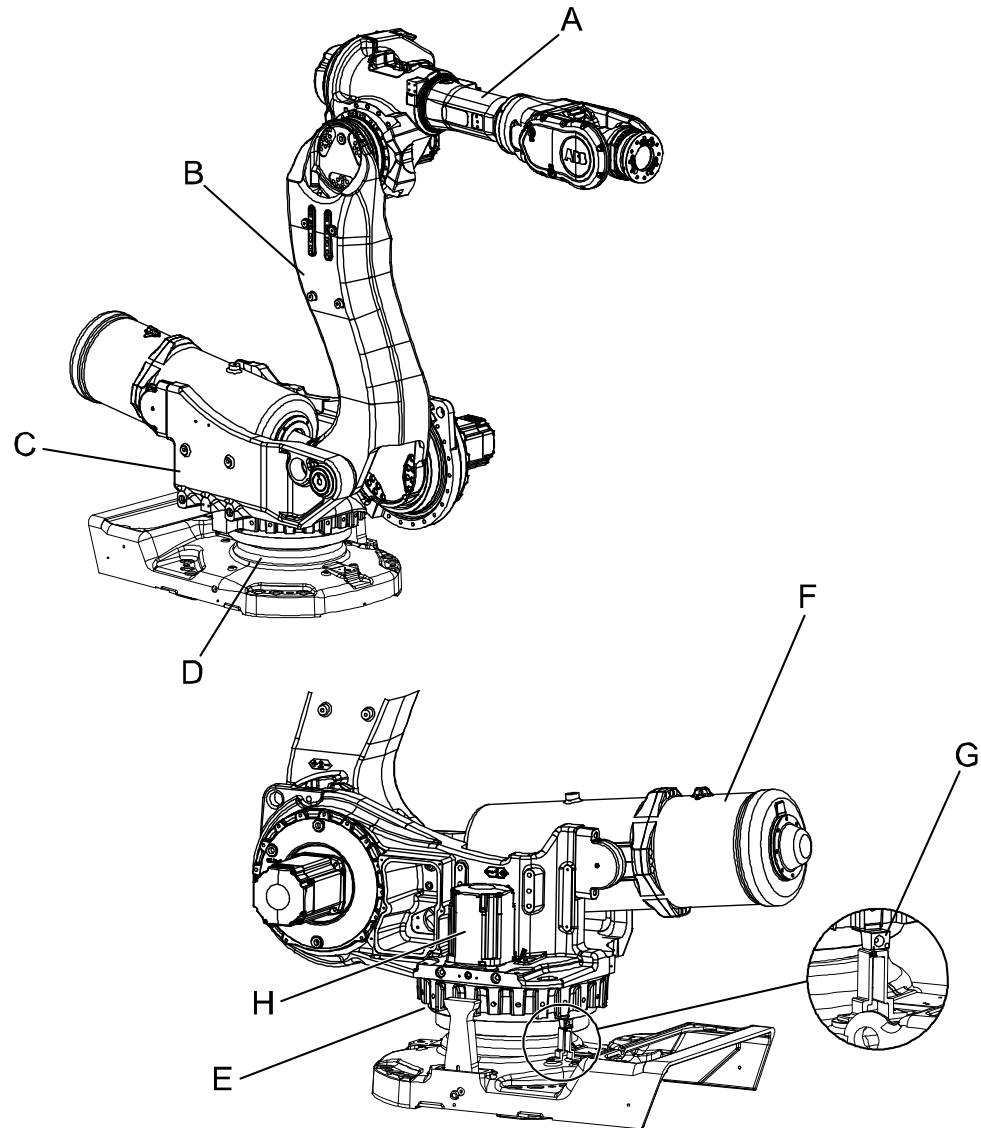

xx030000465

A	Upper arm
B	Lower arm
C	Frame
D	Gearbox, axis 1
E	Base attachment screws
F	Balancing device

Continues on next page

4 Repair

4.3.5 Replacement of complete arm system

Continued

G	Block for calibration
H	Motor axis 1

Required equipment

Equipment, etc.	Art. no.	Note
Lifting accessory, robot	3HAC15607-1	Instruction 3HAC15971-2 is enclosed!
Guide pins M12 x 130	3HAC022637-001	Used to guide the complete arm system when lifting it. Always use the guide pins in pairs! In order to make the refitting easier, it is recommended to use two guide pins of different lengths. Notice that longer guide pins than 140 mm will not be possible to remove from the frame because lack of space after refitting!
Roundsling 1,5 m		Lifting capacity 1,000 kg
Hoisting block	-	Used to adjust the length of the lifting chain.
Isopropanol	-	Used for cleaning mounting surfaces.
Standard toolkit	-	Content is defined in section Standard tools on page 406 .
Other tools and procedures may be required. See references to these procedures in the step-by-step instructions below.		These procedures include references to the tools required.

Deciding calibration routine

Decide which calibration routine to be used, based on the information in the table. Depending on which routine is chosen, action might be required prior to beginning the repair work of the robot, see the table.



	Action	Note
1	Decide which calibration routine to use for calibrating the robot. <ul style="list-style-type: none">Reference calibration. External cable packages (DressPack) and tools can stay fitted on the robot.Fine calibration. All external cable packages (DressPack) and tools must be removed from the robot.	
	If the robot is to be calibrated with reference calibration: Find previous reference values for the axis or create new reference values. These values are to be used after the repair procedure is completed, for calibration of the robot. If no previous reference values exist, and no new reference values can be created, then reference calibration is not possible.	Follow the instructions given in the reference calibration routine on the FlexPendant to create reference values. Creating new values requires possibility to move the robot. Read more about reference calibration for Axis Calibration in Reference calibration routine on page 373 .

Continues on next page

Action	Note
<p>If the robot is to be calibrated with fine calibration: Remove all external cable packages (DressPack) and tools from the robot.</p>	

Removal, arm system

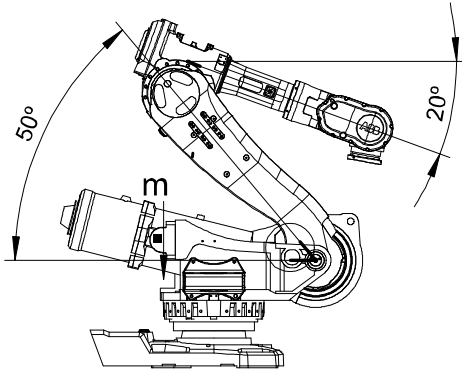
Use this procedure to lift and remove the complete arm system.



Action	Note
1	Decide which calibration routine to use, and take actions accordingly prior to beginning the repair procedure.
2	<p>Run the robot to the position shown in the figure to the right.</p> <p>Release the brakes if necessary, as detailed in section Manually releasing the brakes on page 64.</p>  <p style="text-align: center; font-size: small;">xx0300000632</p>
3	Run the overhead crane to a position above the robot.
4	<p>Fit the <i>lifting accessory</i> and adjust it as detailed in the enclosed <i>instructions</i>.</p> <p>Art. no. is specified in Required equipment on page 226. Make sure the lift is done completely level! How to adjust the lift is described in the enclosed instruction to the lifting accessory! Read the instructions before lifting!</p>
5	<p> DANGER</p> <p>Turn off all:</p> <ul style="list-style-type: none"> • electric power supply to the robot • hydraulic pressure supply to the robot • air pressure supply to the robot <p>Before entering the robot working area.</p>
6	<p>Drain the oil from gearbox axis 1.</p> <p>Detailed in section Changing oil, axis-1 gearbox on page 155.</p>

Continues on next page

4 Repair

4.3.5 Replacement of complete arm system

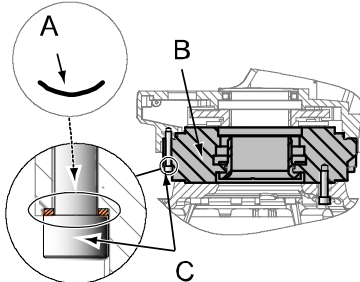

Continued

	Action	Note
7	Disconnect the cabling in the rear of the robot base and remove the cable support plate inside the base.	
8	Pull the disconnected cabling up through the center of the axis-1 gearbox.	How to replace the cabling is detailed in Replacing cable harness, axes 1-6 on page 192 .
9	Remove the motor, axis 1.	Detailed in section Removal, motor axis 1 on page 296 .
10	Remove the <i>block for calibration</i> from the bottom of the frame.	Shown in the figure Location of arm system on page 225 .
11	Unfasten the arm system from the base by unscrewing its 24 attachment screws.	<p>Shown in the figure Location of arm system on page 225.</p>  <p>xx0600003070</p> <p>Parts:</p> <ul style="list-style-type: none"> • A: Serrated lock washer • B: Gearbox axis 1 • C: Attachment screws M12x110
12	Fit two <i>guide pins</i> in two opposite screw holes.	Art. no. is specified in section Required equipment on page 226 .
13	 <p>CAUTION</p> <p>The complete arm system weighs 1250 kg! All lifting equipment used must be sized accordingly!</p>	
14	<p>Lift the arm system carefully and secure it in a safe area. Always move the robot at very low speeds, making sure it does not tip.</p> <p>Continue lifting even if the arm system turns out to be unbalanced despite earlier adjustments! The risk of damaging the interfaces is bigger if the load is lowered unbalanced!</p>	<p>Make sure all hooks and attachments stay in the correct position while lifting the arm system and that the lifting accessory does not wear against sharp edges.</p>

Continues on next page

Refitting, arm system

The procedure describes how to lift and refit the complete arm system.

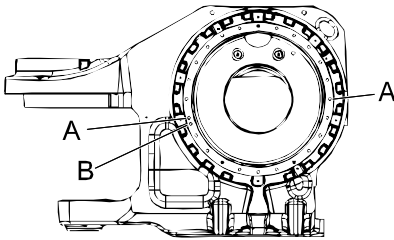

	Action	Note
1	 DANGER Turn off all: <ul style="list-style-type: none"> • electric power supply to the robot • hydraulic pressure supply to the robot • air pressure supply to the robot Before entering the robot working area.	
2	Fit the <i>lifting accessory</i> as detailed in enclosed instruction. Also fit a <i>hoisting block</i> to the front chain. (Used to adjust the balance of the arm system in order to lift it completely level!)	Art. no. is specified in Required equipment on page 226 . Make sure the lift is done completely level! How to adjust the lift is described in the enclosed instruction to the lifting accessory! Follow the instructions before lifting! Releasing the brakes are detailed in section Manually releasing the brakes on page 64 .
3	 CAUTION The complete arm system weighs 1250 kg! All lifting equipment used must be sized accordingly!	
4	Lift the complete arm system and move it at very low speed, making sure it does not tip! Make sure the lift is done completely level. Adjust the length of the chains as detailed in enclosed instruction or with a hoisting block.	
5	Clean the mounting surfaces with isopropanol.	
6	Fit the two <i>guide pins</i> to the frame attachment holes, as shown in the figure to the right. Fit one guide pin next to the guiding hole (for the spring pin in the gearbox) and the other guide pin straight across the frame.  Note Lubricate the guide pins for easier fitting of the arm system.	Dimension is specified in Required equipment on page 226 .  xx0600003441 The figure above shows the frame, view from below. A Attachment holes for the guide pins, M12. B Guiding hole for the spring pin located in the gearbox, axis 1.

Continues on next page

4 Repair

4.3.5 Replacement of complete arm system

Continued

	Action	Note
7	Lubricate the outer surface of the gearbox for easier mating of the gearbox and arm system.	
8	<p>Look through the empty mounting hole of motor 1 to assist in aligning the assembly during refitting of the arm system.</p> <p>The spring pin in the gearbox must be fitted to the guiding hole of the frame (B).</p> <p>Lower the arm system with guidance from the guide pins previously fitted to the frame.</p> <p> Note</p> <p>The refitting must be made completely level! Make sure the lifting accessory is adjusted prior to refitting of arm system.</p>	This is a complex task to be performed with utmost care in order to avoid injury or damage!
9	Refit 22 of the 24 attachment screws before the arm system is completely lowered.	
10	Remove the guide pins and secure the arm system to the base with its 24 <i>attachment screws and washers</i> .	<p>Shown in the figure Location of arm system on page 225.</p> <p>M12 x 110, 12.9 quality UNBRAKO. Tightening torque: 110 Nm.</p> <p>Reused screws may be used, providing they are lubricated as detailed in section Screw joints on page 402 before fitting.</p>
11	Refit the <i>block for calibration</i> at the bottom of the frame.	Shown in the figure Location of arm system on page 225 .
12	Refit the <i>axis-1 motor</i> .	Detailed in section Refitting, motor axis 1 on page 297 .
13	Perform a <i>leak-down test</i> of the axis-1 gearbox.	Detailed in section Performing a leak-down test on page 184 .
14	Refit the <i>cabling</i> in the base.	
15	Refill the gearbox with lubricating oil.	Detailed in section Changing oil, axis-1 gearbox on page 155 .
16	Recalibrate the robot.	<p>Axis Calibration is described in Calibrating with Axis Calibration method on page 372.</p> <p>General calibration information is included in section Calibration on page 359.</p>
17	<p> DANGER</p> <p>Make sure all safety requirements are met when performing the first test run. See Test run after installation, maintenance, or repair on page 108.</p>	

4.4 Upper and lower arm

4.4.1 Replacing the turning disk

Location of turning disk

The turning disk is located in the front of the wrist housing as shown in the figure below.

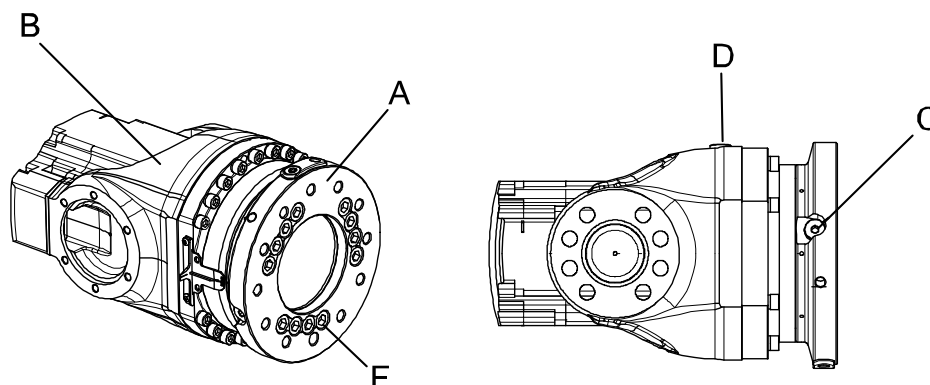

xx0200000217

A	Turning disk
B	Wrist unit
C	Oil plug, draining
D	Oil plug, filling
F	Attachment screws (12 pcs)

Required equipment

Equipment, etc.	Art. no.	Note
Turning disk	For spare part no. see: Spare part lists on page 397.	
O-ring Wrist, type 2	3HAB3772-64 (1 pc) 3HAB3772-61 (12 pcs)	Must be replaced when replacing the turning disk!
Grease	3HAC042536-001	Shell Gadus S2 Used to lubricate the o-rings.
Flange sealant	3HAC034903-001	Loctite 574
Standard toolkit	-	Content is defined in section Standard tools on page 406.
Other tools and procedures may be required. See references to these procedures in the step-by-step instructions below.		These procedures include references to the tools required.

Continues on next page

4 Repair

4.4.1 Replacing the turning disk

Continued

Removing, turning disk

Use this procedure to remove the turning disk.

	Action	Note
1	Run the robot to a position where the <i>oil plug, draining</i> of axis 6 gearbox faces downwards.	Shown in the figure Location of turning disk on page 231 .
2	 DANGER Turn off all: <ul style="list-style-type: none">• electric power supply• hydraulic pressure supply• air pressure supply to the robot, before entering the robot working area.	
3	Remove any equipment fitted to the turning disk.	
4	Drain the axis 6 gearbox.	See section <ul style="list-style-type: none">• Changing oil, axis-6 gearbox on page 170
5	Remove the <i>attachment screws</i> that secure the turning disk.	Shown in the figure Location of turning disk on page 231 .
6	Remove the <i>turning disk</i> .	
7	<i>Foundry Plus:</i> Remove old flange sealant residues and other contamination from the contact surfaces.	

Continues on next page

Refitting, turning disk

Use this procedure to refit the turning disk.

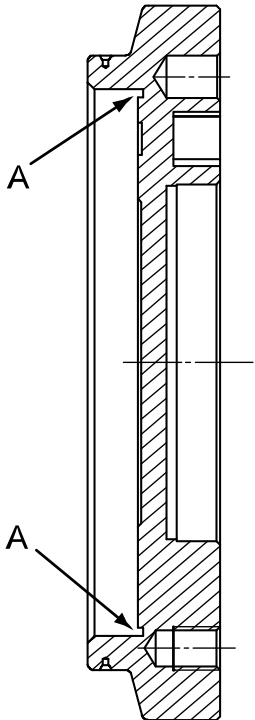
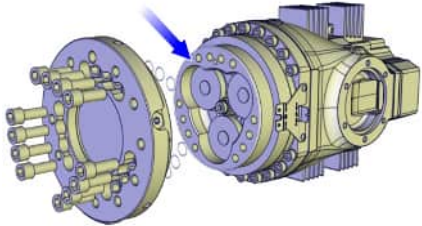
	Action	Note
1	Lubricate the <i>o-ring</i> of the turning disk with <i>grease</i> and fit it to the turning disk. Also fit the 12 <i>o-rings</i> , when refitting the attachment screws.	<p>Art. no. is specified in Required equipment on page 231.</p>  <p>xx0200000218</p> <ul style="list-style-type: none"> A: Sealing surface, o-ring
2	Foundry Plus: Apply Loctite 574 flange sealant on the contact surface.	 <p>xx1400000995</p>
3	Secure the turning disk with its <i>attachment screws</i> .	<p>12 pcs, M12 x 30, 12.9 quality Gleitmo. Tightening torque: 100 Nm. Reused screws may be used, providing they are lubricated as detailed in section Screw joints on page 402 before fitting.</p>
4	Perform a <i>leak-down test</i> of the gearbox axis 6.	Detailed in the section Performing a leak-down test on page 184 .
5	Refill the axis 6 gearbox with oil.	<p>See section</p> <ul style="list-style-type: none"> Changing oil, axis-6 gearbox on page 170
6	Refit any equipment removed during disassembly to the turning disk.	

Continues on next page

4 Repair

4.4.1 Replacing the turning disk

Continued

	Action	Note
7	 DANGER Make sure all safety requirements are met when performing the first test run. See Test run after installation, maintenance, or repair on page 108 .	

4.4.2 Replacement of complete wrist unit

Location of wrist unit

The wrist unit is located on the upper arm as shown in the figure below.

A more detailed view of the component and its position may be found in [Spare part lists on page 397](#).

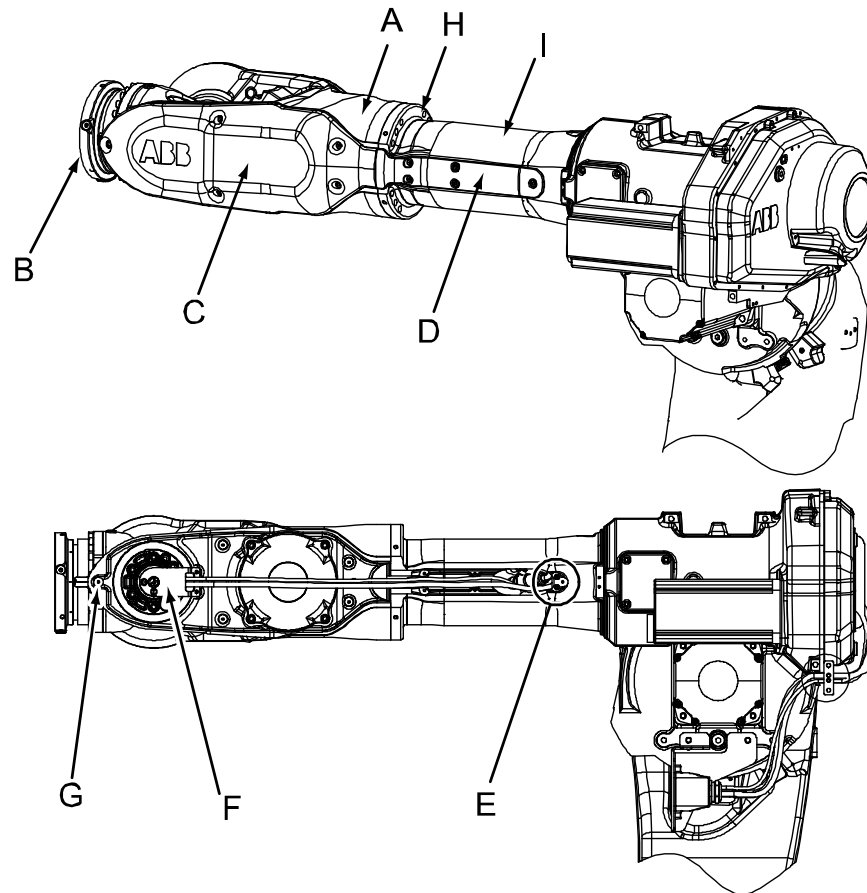

xx020000184

A	Wrist unit
B	Turning disk
C	Cover, wrist unit
D	Cover, upper arm tube
E	Connectors, upper arm tube, with cable bracket (R3.FB5, R3.MP5)
F	Cable bracket
G	Attachment point for lifting tool, wrist unit
H	Wrist unit attachment screws and washers
I	Upper arm tube

Continues on next page

4 Repair

4.4.2 Replacement of complete wrist unit

Continued

Required equipment

Equipment etc.	Art. no.	Note
Wrist unit	For spare part number, see Spare part lists on page 397 .	
Cover for wrist unit	For spare part number, see Spare part lists on page 397 .	
Guide pins M12 x 200	3HAC13056-3	Always use guide pins in pairs!
Lifting accessory, wrist unit	3HAC13605-1	
Standard toolkit	-	Content is defined in section Standard tools on page 406 .
Other tools and procedures may be required. See references to these procedures in the step-by-step instructions below.		These procedures include references to the tools required.
Circuit diagram		See chapter Circuit diagram on page 411 .

Deciding calibration routine



Decide which calibration routine to be used, based on the information in the table. Depending on which routine is chosen, action might be required prior to beginning the repair work of the robot, see the table.

	Action	Note
1	Decide which calibration routine to use for calibrating the robot. <ul style="list-style-type: none">Reference calibration. External cable packages (DressPack) and tools can stay fitted on the robot.Fine calibration. All external cable packages (DressPack) and tools must be removed from the robot.	
	If the robot is to be calibrated with reference calibration: Find previous reference values for the axis or create new reference values. These values are to be used after the repair procedure is completed, for calibration of the robot. If no previous reference values exist, and no new reference values can be created, then reference calibration is not possible.	Follow the instructions given in the reference calibration routine on the FlexPendant to create reference values. Creating new values requires possibility to move the robot. Read more about reference calibration for Axis Calibration in Reference calibration routine on page 373 .
	If the robot is to be calibrated with fine calibration: Remove all external cable packages (DressPack) and tools from the robot.	

Continues on next page

Removal, wrist unit

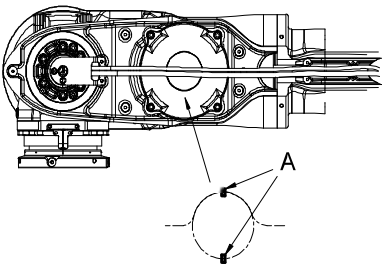
The procedure below details how to remove the complete wrist unit.

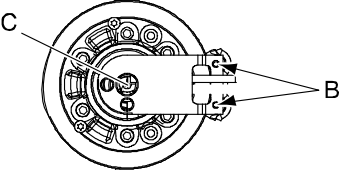
	Action	Note
1	Decide which calibration routine to use, and take actions accordingly prior to beginning the repair procedure.	
2	Remove all equipment fitted to the turning disk.	
3	Turn axis 4 to a position where the <i>cover, upper arm tube and wrist unit</i> , faces upwards. Turn axis 5 to +90°.	 <p>xx0200000185</p>
4	 <p>DANGER</p> <p>Turn off all:</p> <ul style="list-style-type: none"> • electric power supply to the robot • hydraulic pressure supply to the robot • air pressure supply to the robot <p>Before entering the robot working area.</p>	
5	Remove the <i>cover, wrist unit</i> .	Shown in the figure Location of wrist unit on page 235 .
6	Remove the <i>cover, upper arm tube</i> .	Shown in the figure Location of wrist unit on page 235 .
7	Remove the cover of motor, axis 6 and disconnect all connectors beneath.	
8	<p>Loosen the <i>cable bracket, wrist unit</i> on top of the wrist by undoing the three attachment screws.</p> <p>Two of the <i>attachment screws</i> are visibly located at the rear of the bracket and the third located at the bottom of the cable bracket, in the center.</p>	<p>Shown in the figure Location of wrist unit on page 235.</p>  <p>xx0200000254</p> <ul style="list-style-type: none"> • B: Attachment screws, rear of cable bracket (2 pcs) • C: Attachment screw, bottom of cable bracket
9	Pick out the cabling from motor, axis 6 and place it safely on the tube.	
10	Fit the <i>lifting accessory</i> to the wrist unit.	Art. no. is specified in Required equipment on page 236 .

Continues on next page

4 Repair



4.4.2 Replacement of complete wrist unit

Continued

	Action	Note
11	 CAUTION The complete wrist unit weighs 130 kg! All lifting equipment used must be sized accordingly!	
12	Slightly raise the wrist unit to unload the screw joint, facilitating removing the attachment screws.	
13	Remove the <i>wrist unit attachment screws and washers</i> .	Shown in the figure Location of wrist unit on page 235 .
14	Pull the wrist unit out, lift it away and place it on a secure surface.	
15	Disconnect the <i>motor axis 5</i> by disconnecting the two connectors in the upper arm tube (R3.FB5, R3.MP5).	Shown in the figure Location of wrist unit on page 235 .

Refitting, wrist unit

The procedure below details how to refit the complete wrist unit.

	Action	Note
1	 DANGER Turn off all: <ul style="list-style-type: none">• electric power supply to the robot• hydraulic pressure supply to the robot• air pressure supply to the robot Before entering the robot working area.	
2	Fit two <i>guide pins, M12</i> in the upper arm tube, in two of the holes for the <i>wrist unit attachment screws</i> .	Art. no. is specified in Required equipment on page 236 . Shown in the figure Location of wrist unit on page 235 .
3	Fit the <i>lifting tool</i> to the wrist unit.	Art. no. is specified Location of wrist unit on page 235 .
4	 CAUTION The complete wrist unit weighs 130 kg! All lifting equipment used must be sized accordingly!	
5	Lift the wrist unit and guide it to the upper arm tube with help of the guide pins. Make sure the cabling from motor, axis 5 is safely run into the arm tube and does not get jammed.	
6	Reconnect the motor axis 5 by connecting the two <i>connectors inside the upper arm tube</i> (R3.FB5, R3.MP5) and secure the cable bracket with the two attachment screws to the tube.	Shown in the figure Location of wrist unit on page 235 .

Continues on next page

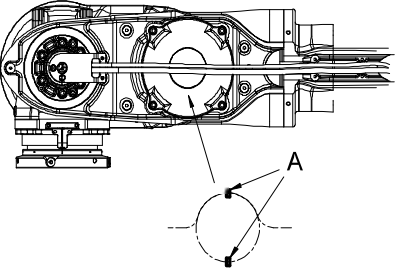
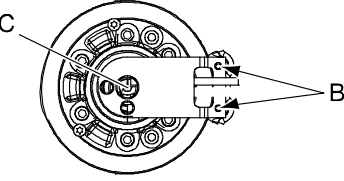
	Action	Note
7	Secure the wrist unit with 10 of the 12 <i>attachment screws and washers</i> .	Shown in the figure Location of wrist unit on page 235 . 12 pcs: M12 x 50, 12.9 quality Gleitmo. Tightening torque: 115 Nm. Reused screws may be used, providing they are lubricated as detailed in section Screw joints on page 402 before fitting.
8	Remove the guide pins and secure the two remaining attachment screws as detailed above.	
9	Remove the lifting tool from the wrist unit.	
10	 Note Axis 5 must be oriented in the correct position (+90°) to allow the motor 6 cover to open!	
11	Place the cabling to motor axis 6 correctly on the upper arm and gently pull the connectors through the hole on top of wrist unit to motor, axis 6. In case of excess of cable length: <ul style="list-style-type: none"> • put the excess cable in a loop in the area shown in the figure and secure with <i>cable straps</i>. Cables are longer in order to fit different upper arm lengths. 	 <p>xx0200000185</p> <p>Parts:</p> <ul style="list-style-type: none"> • A: Cable straps
12	Fasten the <i>cable bracket</i> at top of the wrist unit with three <i>attachment screws</i> . Two of them are visible at the <i>rear attachment point</i> and the third is located on the <i>bottom</i> of the cable bracket, in the center.	 <p>xx0200000254</p> <ul style="list-style-type: none"> • B: Attachment screws, rear attachment point of cable bracket (2 pcs) • C: Attachment screw, bottom of cable bracket
13	Reconnect the connectors to the axis-6 motor and refit the motor cover.	
14	Refit the <i>cover, upper arm tube</i> .	Shown in the figure Location of wrist unit on page 235 .
15	Refit the <i>cover, wrist unit</i> .	Shown in the figure Location of wrist unit on page 235 . Tightening torque: 14 Nm±10%. Screw 3HAB3409-25 (with Loctite), Washer 3HAC062379-001.

Continues on next page

4 Repair

4.4.2 Replacement of complete wrist unit

Continued

	Action	Note
16	Re-calibrate the robot!	Axis Calibration is described in Calibrating with Axis Calibration method on page 372 . General calibration information is included in section Calibration on page 359 .
17	Refit any equipment previously removed from the turning disk.	
18	 DANGER Make sure all safety requirements are met when performing the first test run. See Test run after installation, maintenance, or repair on page 108 .	

4.4.3 Replacement of upper arm

Location of upper arm

The upper arm is located on top of the robot as shown in the following figure. The complete upper arm includes the wrist unit but this section also describes how to remove the upper arm when there is no wrist unit mounted.



Note

The lifting accessory is attached differently depending on whether the wrist unit is mounted on the upper arm or not. The attachment points are shown in the following figure.

Continues on next page

4 Repair

4.4.3 Replacement of upper arm

Continued

A more detailed view of the component and its position may be found in [Spare part lists on page 397](#).

Continues on next page

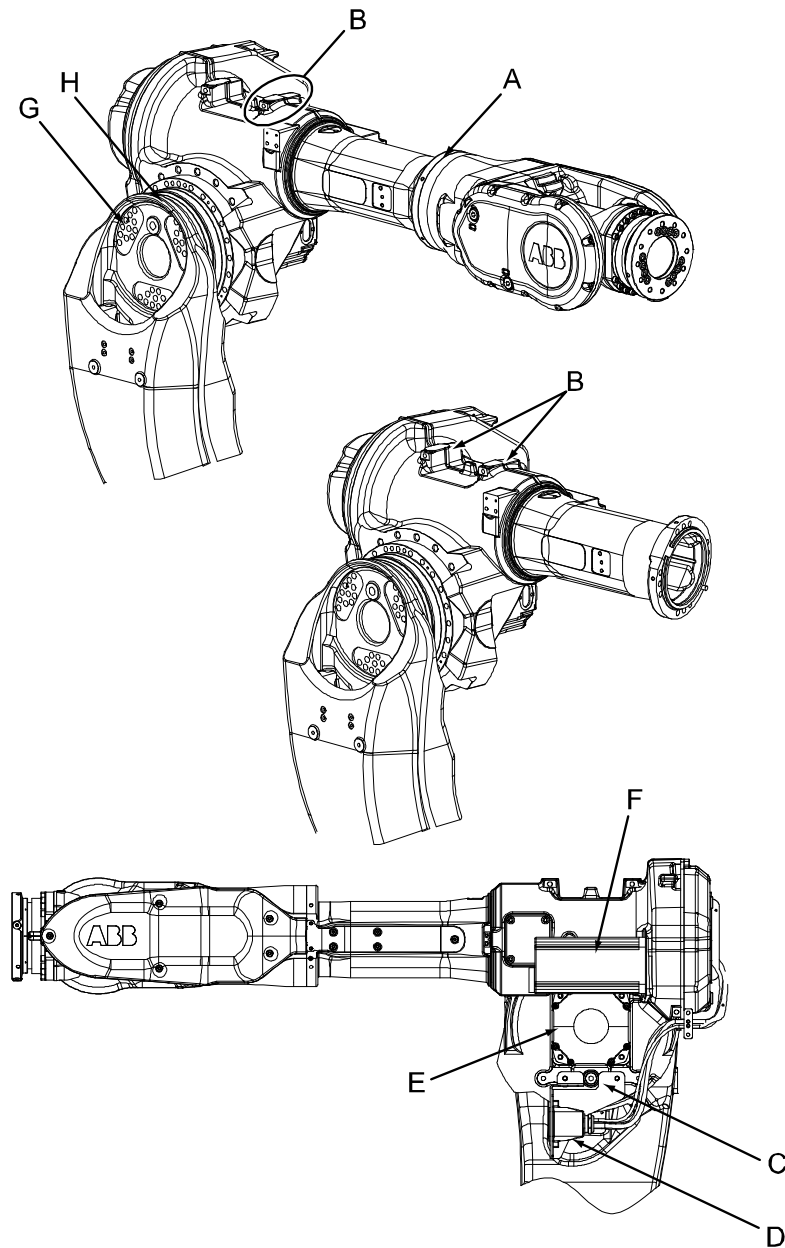

xx020000163

A	Attachment hole for lifting eye, M12 (if wrist unit is mounted)
B	Attachment for lifting accessory, upper arm (2 pcs if there is no wrist unit mounted)
C	Oil plug, draining, gearbox axis 3
D	Cable harness division; connector R2.M5/6
E	Motor, axis 3
F	Motor, axis 4
G	Attachment screws and washers, upper arm
H	Sealing, axis 2/3 (between lower arm and gearbox axis 3)

Continues on next page

4 Repair

4.4.3 Replacement of upper arm

Continued

Required equipment

Equipment	Art. no.	Note
Sealing, axis 3	3HAC17212-1	Always use a new sealing when refitting the upper arm!
Foundry Prime (grey)	3HAC038648-001	To be replaced if damaged.
Washer, axis 3 (3 pcs) Standard and Foundry Plus (ABB Orange)	3HAC038648-002	To be replaced if damaged.
Washer, axis 3 (3 pcs) Standard and Foundry Plus (Graphite White)	3HAC038648-003	To be replaced if damaged.
Guide pins, sealing axis 2/3 80 mm	3HAC14628-1	For guiding the axis-3 sealing.
Guide pins, sealing axis 2/3 100 mm	3HAC14628-2	For guiding the axis-3 sealing.
Power supply	-	24 VDC, max 1,5A For releasing the brakes.
Rotation tool	3HAC17105-1	Used to rotate the motor shaft beneath the motor cover, when brakes are released with 24 VDC power supply.
Lifting eye VLBG M12	3HAC16131-1	
Lifting accessory, upper arm	3HAC15994-1	
Lifting tool (chain)	3HAC15556-1	To be used together with lifting eye, M12 and lifting accessory, upper arm.
Standard toolkit	-	Content is defined in section Standard tools on page 406 .
Other tools and procedures may be required. See references to these procedures in the step-by-step instructions below.		These procedures include references to the tools required.

Deciding calibration routine

Decide which calibration routine to be used, based on the information in the table. Depending on which routine is chosen, action might be required prior to beginning the repair work of the robot, see the table.



	Action	Note
1	Decide which calibration routine to use for calibrating the robot. <ul style="list-style-type: none">Reference calibration. External cable packages (DressPack) and tools can stay fitted on the robot.Fine calibration. All external cable packages (DressPack) and tools must be removed from the robot.	

Continues on next page

Action	Note
<p>If the robot is to be calibrated with reference calibration: Find previous reference values for the axis or create new reference values. These values are to be used after the repair procedure is completed, for calibration of the robot.</p> <p>If no previous reference values exist, and no new reference values can be created, then reference calibration is not possible.</p>	<p>Follow the instructions given in the reference calibration routine on the FlexPendant to create reference values.</p> <p>Creating new values requires possibility to move the robot.</p> <p>Read more about reference calibration for Axis Calibration in Reference calibration routine on page 373.</p>
<p>If the robot is to be calibrated with fine calibration: Remove all external cable packages (DressPack) and tools from the robot.</p>	

Removal, upper arm

The procedure below details how to remove the upper arm.



Action	Note	
1	Decide which calibration routine to use, and take actions accordingly prior to beginning the repair procedure.	
2	Remove all equipment fitted to turning disk.	
3	Move the upper arm to a horizontal position. Rotate axis 4 so that the <i>attachment hole for lifting eye</i> is faced upwards!	Shown in the figure Location of upper arm on page 241 .
4	Rotate axis 5 to position +90°.	
5	 DANGER Turn off all: <ul style="list-style-type: none"> • electric power supply to the robot • hydraulic pressure supply to the robot • air pressure supply to the robot Before entering the robot working area.	
6	<p>Upper arm including wrist unit: Fit the <i>lifting eye, VLBG M12</i> to the <i>attachment hole for lifting eye</i> on the upper arm tube.</p>	<p>Art. no. is specified in Required equipment on page 244.</p> <p>Shown in the figure Location of upper arm on page 241.</p>
7	<p>Upper arm including wrist unit: Fit one of the pieces included in <i>lifting accessory, upper arm</i> to the front <i>attachment for lifting accessory</i> on the upper arm.</p> <p>Upper arm without wrist unit: Fit the <i>lifting accessory, upper arm</i> to both <i>attachments for lifting accessory</i>.</p>	<p>Art. no. is specified in Required equipment on page 244.</p> <p>Attachment point is shown in the figure Location of upper arm on page 241.</p>  Note The different attachment points, depends on whether the wrist unit is mounted or not!

Continues on next page

4 Repair

4.4.3 Replacement of upper arm



Continued

	Action	Note
8	Fasten the <i>lifting tool (chain)</i> onto the lifting eye, the lifting accessory and an overhead crane.	Art. no. is specified in Required equipment on page 244 .
9	Drain the oil from gearbox axis 3.	Detailed in section Changing oil, axis-3 gearbox on page 161 .
10	Disconnect connector R2.M5/6 at the <i>cable harness division</i> as well as all remaining connections between upper and lower arm.	Shown in the figure Location of upper arm on page 241 .
11	Remove the cover on top of the motors, axis 3 and 4 and disconnect all connectors inside the motors.	
12	Remove all brackets securing the cabling to the upper arm by removing their attachment screws respectively.	
13	 CAUTION The complete upper arm weighs 380 kg without any additional equipment fitted! Use a suitable lifting accessory to avoid injury to personnel!	
14	Raise the lifting equipment to take the weight of the upper arm.	
15	In order to release the brake of the axis 3 motor, connect the 24 VDC power supply.  Note When releasing the brake, the position of the upper arm is adjusted to the position given by the lifting equipment.	Connect to connector R2.MP3 <ul style="list-style-type: none"> • +: pin 2 • -: pin 5
16	Remove the axis-3 motor.	See Replacement of motor, axis 3 on page 305 .
17	Carefully remove the <i>attachment screws and washers, upper arm</i> .	Shown in the figure Location of upper arm on page 241 .
18	Lift the upper arm and place it on a secure surface. Make sure the lift is done completely level! In case of necessary adjustments, use the shortening loops on the lifting tool (chain), but make sure to place the chain the right way through the loops!	
19	Remove the <i>sealing, axis 2/3</i> from the lower arm.	Shown in the figure Location of upper arm on page 241 .

Continues on next page

Refitting, upper arm

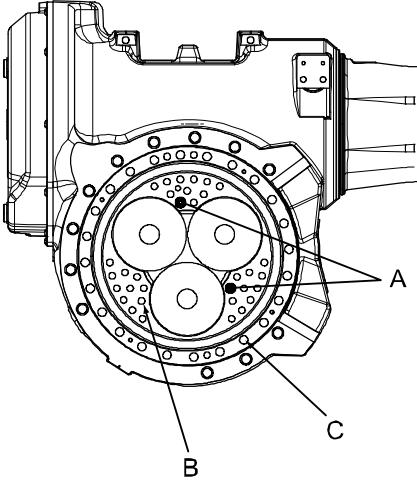
The procedure below details how to refit the upper arm.

	Action	Note
1	<p>Fit the new <i>sealing, axis 2/3</i> onto the axis-3 gearbox and keep it in place by also fitting the two <i>guide pins, sealing axis 2/3</i> in two of the attachment screw holes on the gearbox, see figure to the right.</p>	<p>Always use a new sealing when reassembling! Art. no. is specified in Required equipment on page 244.</p>  <p>xx0200000166</p> <ul style="list-style-type: none"> A Holes for the guide pins (sealing axis 2/3). B Holes for the upper arm attachment screws (33 pcs). C Holes for the gearbox attachment screws (not affected in this instruction).
2	<p>Upper arm including wrist unit: Fit the <i>lifting eye, VLBG M12</i> to the attachment hole, <i>lifting eye</i> on the wrist unit.</p>	<p>Art. no. is specified in Required equipment on page 244. Shown in the figure Location of upper arm on page 241.</p>
3	<p>Upper arm including wrist unit: Fit one of the pieces included in the <i>lifting accessory, upper arm</i> to the front attachment for the <i>lifting accessory</i> on the upper arm.</p> <p>Upper arm without wrist unit: Fit the <i>lifting accessory, upper arm</i> to the both attachments for the <i>lifting accessory</i> on the upper arm.</p>	<p>Art. no. is specified in Required equipment on page 244. Attachment points are shown in the figure Location of upper arm on page 241.</p> <p> Note The different attachment points, depends on whether the wrist unit is mounted or not!</p>
4	<p>Fasten the <i>lifting tool (chain)</i> onto the lifting eye, the lifting accessory and an overhead crane.</p>	<p>Art. no. is specified in Required equipment on page 244.</p>
5	<p> CAUTION</p> <p>The complete upper arm weighs 380 kg without any additional equipment fitted! Use a suitable lifting accessory to avoid injury to personnel!</p>	

Continues on next page

4 Repair

4.4.3 Replacement of upper arm

Continued

	Action	Note
6	Lift the upper arm and move to its mounting position.  CAUTION Make sure the lift is done completely level!	
7	Fit in the gearbox attachment holes with the attachment holes on the lower arm with the guide pins.	Art. no. is specified in Required equipment on page 244 .
8	Fit the three <i>washers</i> to be placed beneath the attachment screws.	Shown in the figure Location of upper arm on page 241 .
9	Insert 31 of the 33 <i>attachment screws, upper arm</i> into the attachment holes in the lower arm. Do not remove the guide pins until the attachment screws are tightened as detailed below.	Shown in the figure Location of upper arm on page 241 . Removing the plastic mechanical stops may be required before fitting the upper arm. If guide pins are removed before the screws are tightened, the sealing can be involuntarily moved into wrong position.
10	Secure the lower arm to gearbox axis 3, with the attachment screws.	33 pcs: M12 x 50; 12.9 quality UN-BRAKO, tightening torque: 120 Nm. Reused screws may be used, providing they are lubricated as detailed in section Screw joints on page 402 before fitting.
11	Remove the guide pins and fit the two remaining attachment screws. Tighten them as detailed above!	
12	Refit the axis-3 motor.	See Replacement of motor, axis 3 on page 305 .
13	Remove the lifting accessories.	
14	Refit any cabling removed during the removal process.	
15	Reconnect all connectors inside motors, axis 3 and 4. Refit the motor covers.	
16	Reconnect connector R2.M5/6 gently at the cable harness division point, with 2 screws, M6. Be careful not to bend the attachment plate when fastening the screws!	
17	Perform a leakdown test.	Detailed in section Performing a leakdown test on page 184 .
18	Refill the gearbox with oil.	Detailed in section Changing oil, axis-3 gearbox on page 161 .
19	Re-calibrate the robot.	Axis Calibration is described in Calibrating with Axis Calibration method on page 372 . General calibration information is included in section Calibration on page 359 .

Continues on next page

	Action	Note
20	 DANGER Make sure all safety requirements are met when performing the first test run. See Test run after installation, maintenance, or repair on page 108 .	

4 Repair

4.4.4 Replacement of complete lower arm

4.4.4 Replacement of complete lower arm

Location of lower arm

The lower arm is located as shown in the figure below.

A more detailed view of the component and its position may be found in [Spare part lists on page 397](#).

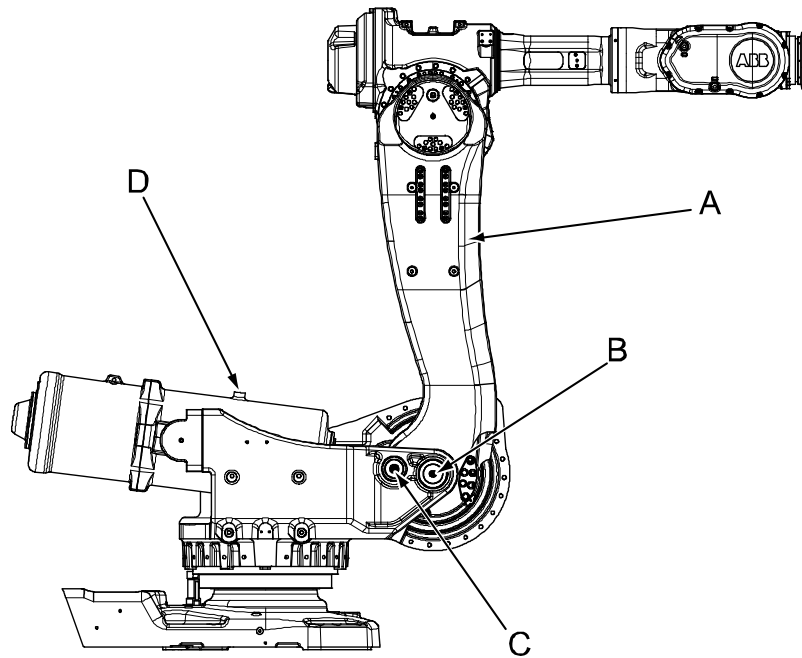

xx030000474

A	Lower arm
B	Pivot point, axis 2
C	Front shaft, balancing device, including securing screw
D	Attachment for lifting equipment, balancing device

Internal components, lower arm

The internal components of the lower arm are located as shown in the figure below:

- The figure (1) shows a cut between the lower arm and the gearbox axis 3. The location of the sealing axis 2/3 is identical between the lower arm and the axis 2.
- The figure (2) shows a cut through the lower arm pivot point in axis 2 (item B in the figure above!).

Continues on next page

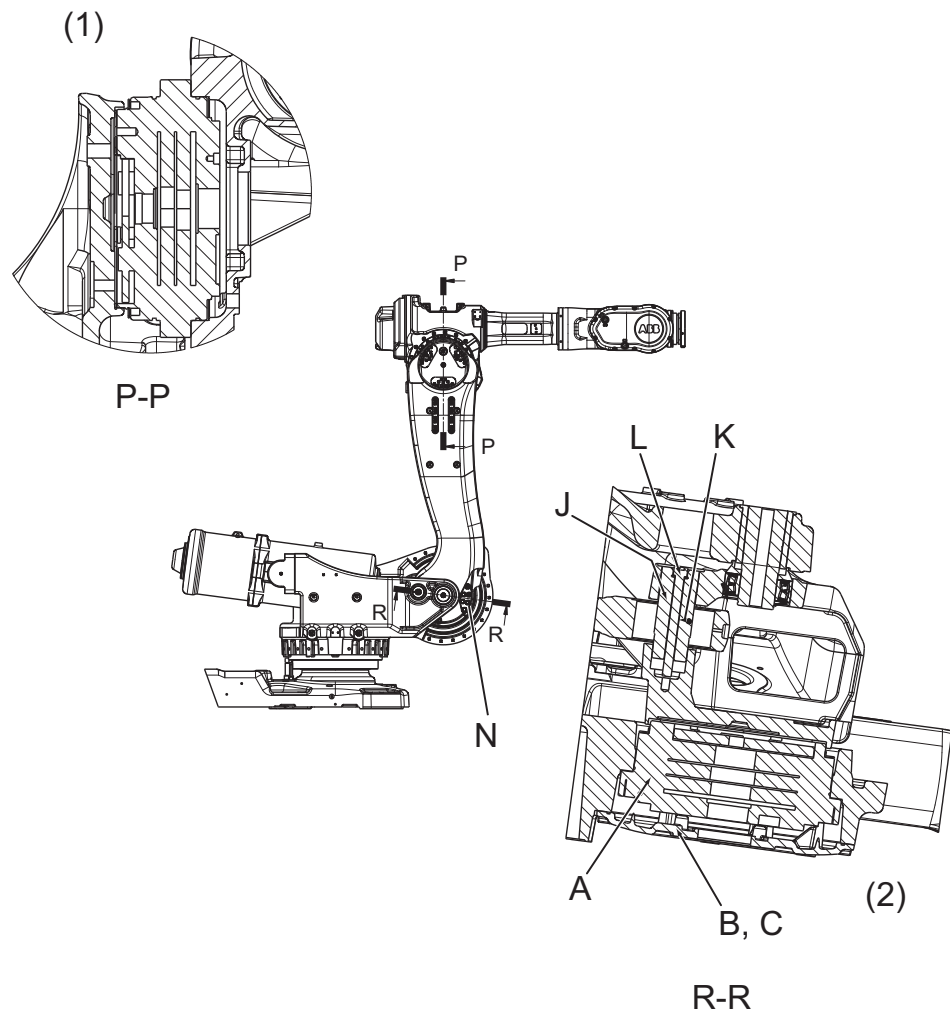

xx0300000475

A	Gearbox
B	Cover axis 2
C	O-ring
J	Shaft, balancing device
K	Grease
L	Securing screw and washer, balancing device shaft
N	Attachment screws and washers

Continues on next page

4 Repair

4.4.4 Replacement of complete lower arm

Continued

Internal components for robots with protection Standard

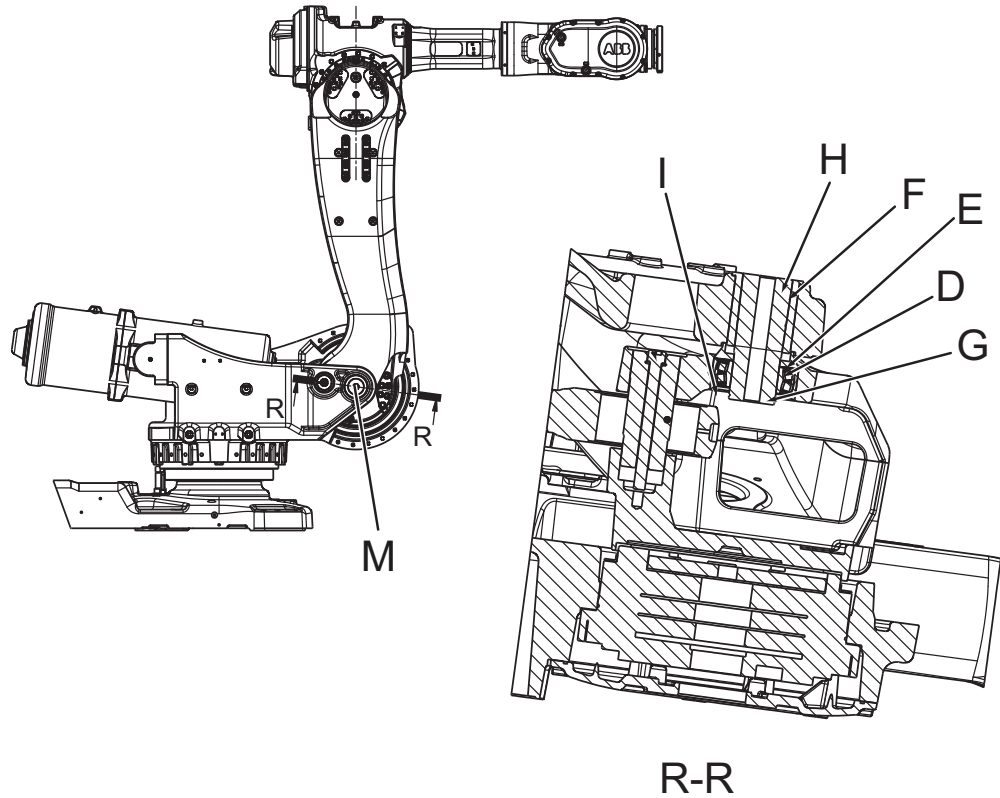

xx110000955

D	Bearing
E	Thrust washer
F	Bushing
G	Retaining ring, shaft
H	Shaft, lower arm
I	Protection washer
M	Protection plug

Continues on next page

Internal components for robots with protection Foundry Plus

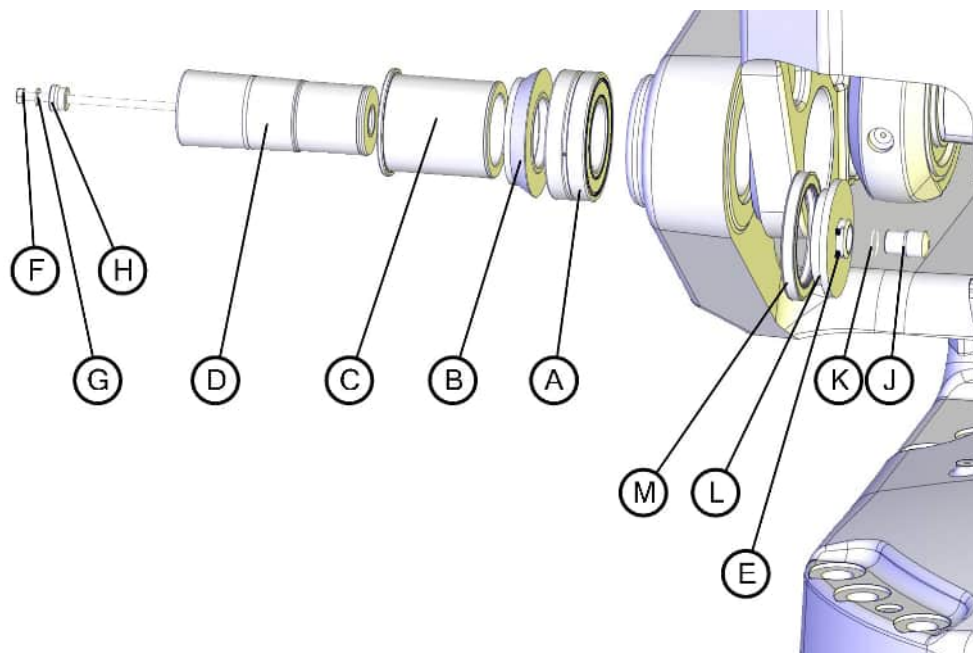

xx110000954

A	Bearing
B	Thrust washer
C	Bushing
D	Shaft, lower arm
E	Set screw with cup point, M4x6 (2 pcs)
F	Hexagon bolt M8x190
G	Conical spring washer
H	Shaft tap
J	Short shaft sealing cover
K	O-ring
L	Sealing cover
M	Radial sealing with dust lip

Required equipment

Equipment, etc.	Art. no.	Note
Bearing	For spare part number see: <ul style="list-style-type: none"> Spare part lists on page 397. 	Always use a new bearing when reassembling!
Sealing, axis 2	For spare part number see: <ul style="list-style-type: none"> Spare part lists on page 397. 	Always use a new sealing when reassembling!

Continues on next page

4 Repair

4.4.4 Replacement of complete lower arm

Continued

Equipment, etc.	Art. no.	Note
VK-Cover VK 120x12	For spare part number see: <ul style="list-style-type: none"> • Spare part lists on page 397. 	Mount on new lower arm or replace if damaged.
Lifting eye M12	3HAC14457-3	Used to lift the balancing device, if it is equipped with a threaded hole.
Shackle, balancing device	3HAC 020997-1	
Press equipment, balancing device shaft	3HAC076202-001	For replacing the balancing device shaft. User instructions are enclosed with the tool.
Lifting accessory, lower arm	3HAC14691-1	Tool that may be rented from ABB Robotics. Includes: <ul style="list-style-type: none"> • two guidings, 3HAC 14445-1, must be used for guiding the sealing, axis 2/3.
Rotation tool	3HAC17105-1	Used to rotate the motor pinion and gear if necessary, when brakes are released.
Hydraulic pump, 80 MPa	3HAC13086-1	To be used with the press and puller tools. See technical specifications in the user instructions for the press equipment.
Hydraulic pump, 150 MPa (Glycerin)	3HAC021563-012	To be used with the press and puller tools. See technical specifications in the user instructions for the press equipment.
Puller device, axis 2 shaft	3HAC075427-001	Hydraulic pressing accessory. User instructions are enclosed with the tool.
Press device, axis 2 shaft	3HAC076203-001	Hydraulic pressing accessory. User instructions are enclosed with the tool.
Press tool, axis 2 bearing	3HAC13527-1	
Retaining ring plier	-	
Grease	3HAC042536-001	For lubrication of the shaft hole.
Isopropanol	11771012-208	For cleaning of the shaft.
Standard toolkit	-	Content is defined in section Standard tools on page 406.
Other tools and procedures may be required. See references to these procedures in the step-by-step instructions below.		These procedures include references to the tools required.

Continues on next page

Deciding calibration routine

Decide which calibration routine to be used, based on the information in the table. Depending on which routine is chosen, action might be required prior to beginning the repair work of the robot, see the table.

	Action	Note
1	Decide which calibration routine to use for calibrating the robot. <ul style="list-style-type: none"> Reference calibration. External cable packages (DressPack) and tools can stay fitted on the robot. Fine calibration. All external cable packages (DressPack) and tools must be removed from the robot. 	
	If the robot is to be calibrated with reference calibration: Find previous reference values for the axis or create new reference values. These values are to be used after the repair procedure is completed, for calibration of the robot. If no previous reference values exist, and no new reference values can be created, then reference calibration is not possible.	Follow the instructions given in the reference calibration routine on the FlexPendant to create reference values. Creating new values requires possibility to move the robot. Read more about reference calibration for Axis Calibration in Reference calibration routine on page 373 .
	If the robot is to be calibrated with fine calibration: Remove all external cable packages (DressPack) and tools from the robot.	

Removal, lower arm

The procedure below details how to remove the complete lower arm.



	Action	Note
1	Decide which calibration routine to use, and take actions accordingly prior to beginning the repair procedure.	
2	 DANGER Turn off all: <ul style="list-style-type: none"> electric power supply to the robot hydraulic pressure supply to the robot air pressure supply to the robot Before entering the robot working area.	
3	Remove the <i>upper arm</i> .	Detailed in section Removal, upper arm on page 245 .
4	Disconnect and remove the <i>cables</i> from inside the lower arm. Release any cable attachments.	Detailed in section Replacing cable harness, axes 1-6 on page 192 .
5	Apply the <i>lifting eye, M12</i> to the balancing device and raise to unload the weight of the device.	Art. no. is specified in Required equipment on page 253 . Attachment is shown in the figure Location of lower arm on page 250 .

Continues on next page

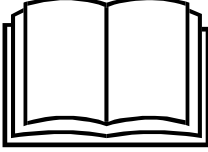

4 Repair

4.4.4 Replacement of complete lower arm

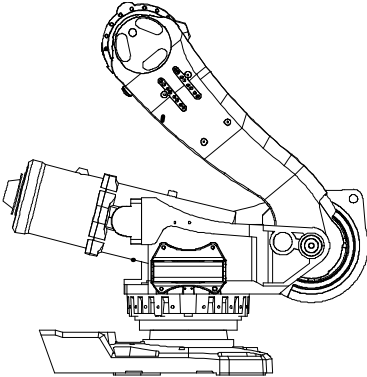
Continued

	Action	Note
6	<p>Unload the balancing device in order to make the piston rod and front ear adjustable when pulling the front shaft out.</p> <p> DANGER</p> <p>Handling the tool incorrectly will cause serious injury. Read and follow enclosed user instructions for the tool.</p>	<p>Detailed in section Unloading the balancing device on page 286.</p>
7	<p>Remove the securing screw from the balancing device <i>front shaft</i>.</p>	<p>Shown in the figure Location of lower arm on page 250.</p>
8	<p>Pull the shaft out using the <i>press equipment, balancing device shaft</i>, according to user instructions enclosed with the equipment.</p> <p></p> <p>xx0900000813</p> <p>Go to the user instructions enclosed with the press tool.</p> <p> DANGER</p> <p>Handling the tool incorrectly will cause serious injury. Read and follow enclosed user instructions for the tool.</p>	<p>Art. no. is specified in Required equipment on page 253. User instructions are enclosed with the tool.</p> <p> Note</p> <p>Make sure to keep the balancing device unloaded.</p>
9	<p>Lower the balancing device until it rests safely against the bottom of the frame.</p>	
10	<p>Move the lower arm backwards to the lowest position possible.</p>	<p></p> <p>xx0400001028</p>
11	<p>Apply the <i>lifting accessory</i> to the lower arm.</p>	<p>Art. no. is specified in Required equipment on page 253.</p>
12	<p>Drain the oil from gearbox 2.</p>	<p>Detailed in section Changing oil, axis-2 gearbox on page 158.</p>

Continues on next page

	Action	Note
13	 CAUTION The lower arm weighs 160 kg! All lifting equipment used must be sized accordingly!	
14	Raise the tool to unload the lower arm.	
15	Remove the lower arm shaft and all additional components, as detailed in section Replacement of lower arm shaft on page 260 .  DANGER Handling the tool incorrectly will cause serious injury. Read and follow enclosed user instructions for the tool.	
16	Remove the <i>attachment screws and washers</i> that attach the lower arm to the gearbox axis 2.	Shown in the figure Internal components, lower arm on page 250 .
17	Lift the lower arm and place it on a secure surface.	

Refitting, lower arm

The procedure below details how to refit the lower arm.



	Action	Note
1	 DANGER Turn off all: <ul style="list-style-type: none"> • electric power supply to the robot • hydraulic pressure supply to the robot • air pressure supply to the robot Before entering the robot working area.	
2	Fit a new <i>VK-cover</i> on a new lower arm or replace the existing if damaged.	Part no. is specified in Required equipment on page 253 .

Continues on next page

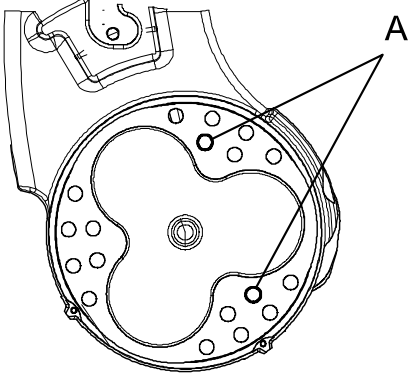

4 Repair

4.4.4 Replacement of complete lower arm

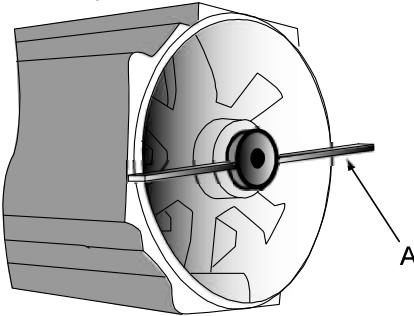
Continued

	Action	Note
3	Fit two <i>guidings</i> in the attachment holes of the lower arm.	<p>Art. no. is specified in Required equipment on page 253.</p>  <p>xx0300000548</p> <p>A: Attachment holes for the two guidings</p>
4	Fit the new <i>sealing, axis 2/3</i> on the guidings.	<p>Always use a new sealing when reassembling!</p> <p>Art. no. is specified in Required equipment on page 253.</p>
5	Apply the <i>lifting tool</i> to the lower arm.	<p>Art. no. is specified in Required equipment on page 253.</p>
6	 CAUTION The lower arm weighs 160 kg! All lifting equipment used must be sized accordingly!	
7	Lift the lower arm and move it to its mounting position.	
8	In case the hole pattern of the lower arm and the gearbox axis 2 does not match, use power supply to release the motor axis 2 brakes and rotate the pinion and gear with the <i>rotational tool</i> .	<p>Connect power supply to connector R2.MP2</p> <ul style="list-style-type: none"> • +: pin 2 • -: pin 5  <p>xx0200000165</p> <p>The rotation tool (A) is used beneath the motor cover, directly on the motor shaft as shown in figure above.</p> <p>Art. no. is specified in Required equipment on page 253.</p>
9	Disconnect the power supply, if used.	

Continues on next page

	Action	Note
10	Secure the lower arm with 16 of the 18 <i>attachment screws and washers</i> in gearbox, axis 2.	18 pcs: M16 x 50, tightening torque: 300 Nm. Reused screws may be used, providing they are lubricated as detailed in section Screw joints on page 402 before fitting. Shown in the figure Internal components, lower arm on page 250 .
11	Remove the guidings and secure the two remaining screws as detailed above!	
12	Refit the lower arm shaft and all additional components, as detailed in section Replacement of lower arm shaft on page 260 .  DANGER Handling the tool incorrectly will cause serious injury. Read and follow enclosed user instructions for the tool.	
13	Remove the lifting tool from the lower arm.	
14	Refit and restore the balancing device.	See section Replacing the balancing device on page 282 .
15	Refit the upper arm.	See section Refitting, upper arm on page 247 .
16	Perform a leak-down test.	See section Performing a leak-down test on page 184 .
17	Refill the gearbox with oil.	See section Changing oil, axis-2 gearbox on page 158 .
18	Refit and reconnect all cables inside the lower arm. Resecure any cable attachments.	Detailed in section Replacing cable harness, axes 1-6 on page 192 .
19	Recalibrate the robot!	Axis Calibration is described in Calibrating with Axis Calibration method on page 372 . General calibration information is included in section Calibration on page 359 .
20	 DANGER Make sure all safety requirements are met when performing the first test run. See Test run after installation, maintenance, or repair on page 108 .	

4 Repair

4.4.5 Replacement of lower arm shaft

4.4.5 Replacement of lower arm shaft

Prerequisites

This section details how to remove and refit the lower arm shaft as a step in the procedure of removing/refitting the complete lower arm. To perform the procedure described in this section, it is required that the preceding instructions in section [Replacement of complete lower arm on page 250](#) are followed! These include:

- removing the upper arm
- removing the cabling in the lower arm
- unloading the balancing device and removing the front eye shaft
- draining the oil in gearbox axis 2
- unloading the lower arm with specific lifting equipment.

Components, lower arm shaft for robots with protection Standard

The figure shows components fitted to the lower arm shaft when the robot has protection Standard.

The figure shows IRB 6600, but is also valid for IRB 6650S!

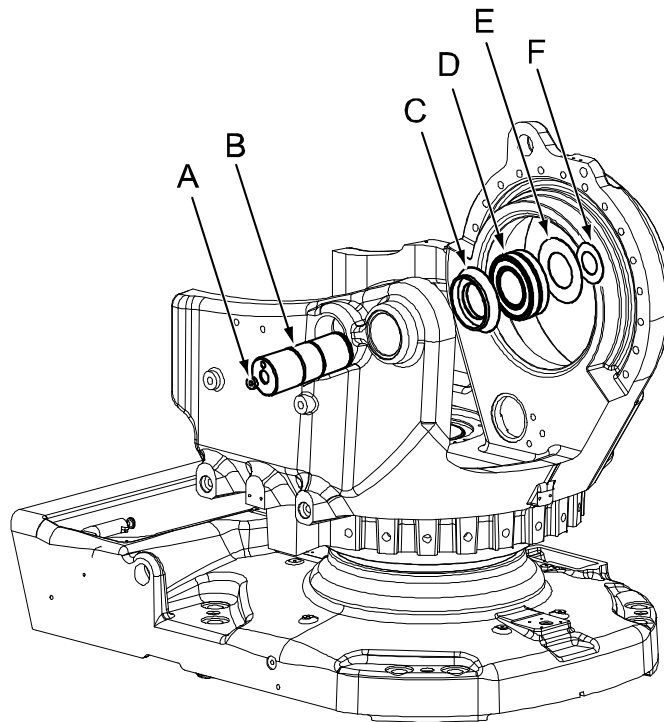

xx030000487

A	Protection plug
B	Lower arm shaft (axis 2 shaft)
C	Thrust washer
D	Bearing
E	Protection washer
F	Retaining ring

Continues on next page

Components, lower arm shaft for robots with protection Foundry Plus

The figure shows components fitted to the lower arm shaft when the robot has protection Foundry Plus.

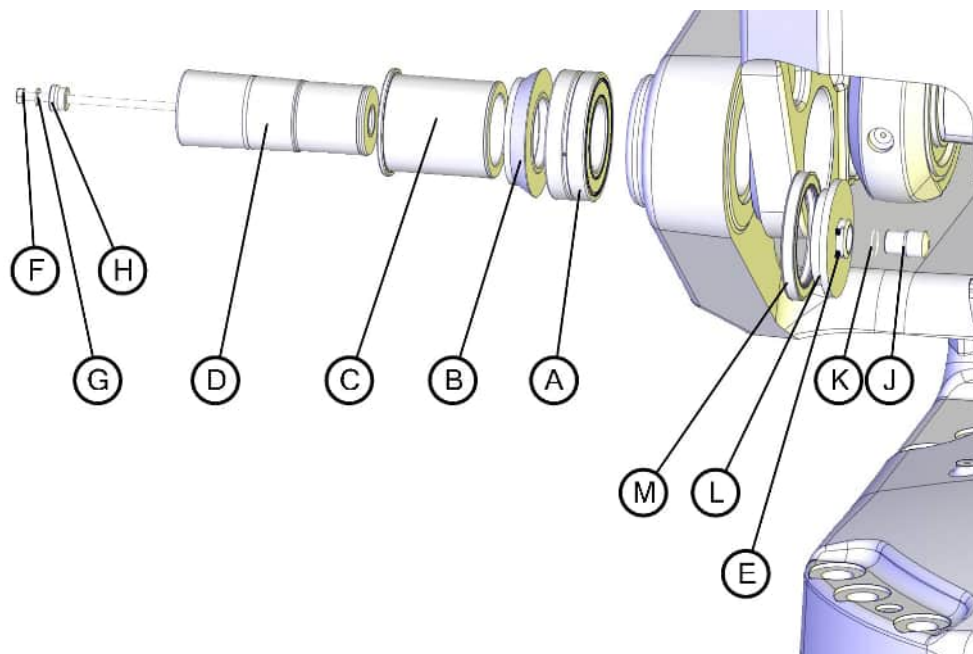

xx110000954

A	Bearing
B	Thrust washer
C	Bushing
D	Shaft for the lower arm
E	Set screw with cup point, M4x6 (2 pcs)
F	Hexagon bolt M8x190
G	Conical spring washer 8.4x16x1.6
H	Shaft tap
J	Shaft for the sealing cover
K	O-ring
L	Sealing cover
M	Radial sealing with dust lip

Required equipment

Equipment	Article number	Note
Bearing	For spare part number see: <ul style="list-style-type: none"> Spare part lists on page 397. 	Always use a new bearing when reassembling!
Puller device, axis 2 shaft	3HAC075427-001	Hydraulic pressing accessory. User instructions are enclosed with the tool.

Continues on next page

4 Repair

4.4.5 Replacement of lower arm shaft

Continued

Equipment	Article number	Note
Press device, axis 2 shaft and bearing	3HAC076203-001	Hydraulic pressing accessory. User instructions are enclosed with the tool.
Hydraulic pump, 80 MPa	3HAC13086-1	To be used with the press and puller tools. See technical specifications in the user instructions for the press equipment.
Hydraulic pump, 150 MPa (Glycerin)	3HAC021563-012	
Retaining ring plier	-	
Isopropanol	11771012-208	For cleaning the shaft.
Grease	3HAB3537-1	For lubrication of the bearing.
Glycerin	-	For lubrication of the shaft.
Rust preventive	3HAC026621-001	Equivalent: <ul style="list-style-type: none"> • Mercasol 3106
Locking liquid (only for robots with protection Foundry Plus and Foundry Prime)	3HAB7116-1	Loctite 243



Removal, lower arm shaft from robot with protection Standard

Use this procedure to remove the lower arm shaft if the robot has protection Standard.

If encountering any problems when removing the shaft, contact ABB Robotics!

	Action	Note/Illustration
1	 WARNING This procedure is a step in the complete procedure of removing the lower arm! Make sure all the preceding steps specified in Replacement of lower arm shaft on page 260 are made before removing the lower arm shaft!	
2	Remove the <i>protection plug</i> .	Shown in the figure Components, lower arm shaft for robots with protection Standard on page 260 !
3	Remove the <i>protection washer</i> and the <i>retaining ring</i> .	Shown in the figure Components, lower arm shaft for robots with protection Standard on page 260 ! Use a plier for the retaining ring.

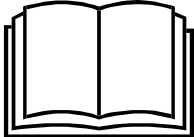
Continues on next page

	Action	Note/Illustration
4	<p>Pull out the axis-2 shaft with the <i>puller device</i> according to user instructions enclosed with the equipment.</p>  <p>xx0900000813</p> <p>Go to the user instructions enclosed with the press tool.</p> <p> DANGER</p> <p>Handling the tool incorrectly will cause serious injury.</p> <p>Read and follow enclosed user instructions for the tool.</p>	<p>Art. no. is specified in Required equipment on page 261!</p> <p>User instructions are enclosed with the tool.</p>
5	<p>Remove the <i>bearing</i> and <i>thrust washer</i> from the shaft hole in the lower arm, recommendable after removing the complete lower arm as detailed in section Replacement of complete lower arm on page 250.</p>	

Removal, lower arm shaft on robot with protection Foundry Plus

Use this procedure to remove the lower arm shaft if the robot has protection Foundry Plus.

If encountering any problems when removing the shaft, contact ABB Robotics!



	Action	Note
1	<p> WARNING</p> <p>This procedure is a step in the complete procedure of removing the lower arm! Make sure all the preceding steps specified in Replacement of lower arm shaft on page 260 are made before removing the lower arm shaft!</p>	
2	<p>Remove the two <i>set screws</i>.</p>	<p>Shown in the figure Components, lower arm shaft for robots with protection Foundry Plus on page 261.</p>
3	<p>Remove the <i>shaft sealing cover</i>.</p>	
4	<p>Remove the <i>sealing cover</i>.</p>	
5	<p>Remove the <i>radial sealing</i>, if the lower arm is to be replaced with a new one.</p> <p>If the same lower arm is refitted, the radial sealing can be left in the lower arm.</p>	
6	<p>Remove the <i>hexagon bolt</i> with the <i>washer</i> and <i>shaft tap</i>.</p>	

Continues on next page

4 Repair

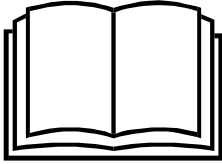

4.4.5 Replacement of lower arm shaft

Continued

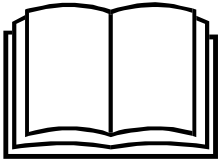

	Action	Note
7	<p>Pull out the axis-2 shaft with the <i>puller device</i> according to user instructions enclosed with the equipment.</p>  <p>xx0900000813</p> <p>Go to the user instructions enclosed with the press tool.</p> <p> DANGER</p> <p>Handling the tool incorrectly will cause serious injury. Read and follow enclosed user instructions for the tool.</p>	<p>Art. no. is specified in Required equipment on page 261! User instructions are enclosed with the tool.</p>
8	<p>Remove the <i>bearing</i> and <i>thrust washer</i> from the shaft hole in the lower arm, recommendable after removing the complete lower arm as detailed in section Replacement of complete lower arm on page 250.</p>	

Refitting, lower arm shaft on robot with protection Standard

Use this procedure to refit the lower arm shaft if the robot has protection Standard.

	Action	Note/Illustration
1	<p>Clean the shaft with <i>isopropanol</i> and lubricate it with <i>glycerin</i>.</p>	<p>Art. no. is specified in Required equipment on page 261!</p>
2	<p>Push the shaft in by hand.</p>	
3	<p>Refit the <i>thrust washer</i> to the shaft.</p>	<p>Also shown in the figure Components, lower arm shaft for robots with protection Standard on page 260!</p>
4	<p>Fit the axis-2 shaft with the <i>press device</i>, <i>axis 2 shaft</i> according to user instructions enclosed with the equipment.</p>  <p>xx0900000813</p> <p>Go to the user instructions enclosed with the press tool.</p> <p> DANGER</p> <p>Handling the tool incorrectly will cause serious injury. Read and follow enclosed user instructions for the tool.</p>	<p>Art. no. is specified in Required equipment on page 261! User instructions are enclosed with the tool.</p>

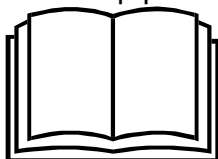
Continues on next page

	Action	Note/Illustration
5	Remove the press device, axis 2 shaft.	
6	Apply <i>grease</i> to the location of the shaft where the bearing is to be mounted.	Art. no. is specified in Required equipment on page 261
7	<p>Press in the new <i>bearing</i> with the <i>press tool, axis 2 bearing</i> according to user instructions enclosed with the equipment..</p>  <p>xx0900000813</p> <p>Go to the user instructions enclosed with the press tool.</p>  <p>DANGER</p> <p>Handling the tool incorrectly will cause serious injury. Read and follow enclosed user instructions for the tool.</p>	 <p>Note</p> <p>Always use a new bearing when reassembling!</p> <p>Art. no. is specified in Required equipment on page 261. User instructions are enclosed with the tool.</p>
8	Refit the <i>protection washer</i> and the <i>retaining ring</i> .	Shown in the figure Components, lower arm shaft for robots with protection Standard on page 260 .
9	Refit the <i>protection plug</i> .	
10	Proceed with the refitting procedure of the lower arm, detailed in section Replacement of complete lower arm on page 250 .	

Refitting, lower arm shaft on robot with protection Foundry Plus

Use this procedure to refit the lower arm shaft if the robot has protection Foundry Plus.





	Action	Note/Illustration
1	Clean the shaft with <i>isopropanol</i> and lubricate it with <i>glycerin</i> .	Art. no. is specified in Required equipment on page 261 !
2	Push the shaft in by hand.	
3	Refit the <i>thrust washer</i> to the shaft.	Also shown in the figure Components, lower arm shaft for robots with protection Foundry Plus on page 261 !

Continues on next page

4 Repair

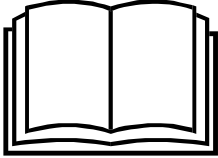
4.4.5 Replacement of lower arm shaft

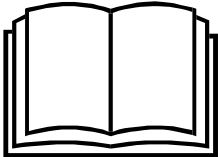
Continued

	Action	Note/Illustration
4	<p>Fit the axis-2 shaft with the <i>press device, axis 2 shaft</i> according to user instructions enclosed with the equipment.</p>  <p>xx0900000813</p> <p>Go to the user instructions enclosed with the press tool.</p> <p> DANGER</p> <p>Handling the tool incorrectly will cause serious injury. Read and follow enclosed user instructions for the tool.</p>	<p>Art. no. is specified in Required equipment on page 261!</p> <p>User instructions are enclosed with the tool.</p>
5	<p>Remove the press device, axis 2 shaft.</p>	
6	<p>Apply <i>grease</i> to the location of the shaft where the bearing is to be mounted.</p>	<p>Art. no. is specified in Required equipment on page 261</p>
7	<p>Press in the new <i>bearing</i> with the <i>press tool, axis 2 bearing</i> according to user instructions enclosed with the equipment.</p>  <p>xx0900000813</p> <p>Go to the user instructions enclosed with the press tool.</p> <p> DANGER</p> <p>Handling the tool incorrectly will cause serious injury. Read and follow enclosed user instructions for the tool.</p>	<p> Note</p> <p>Always use a new bearing when reassembling!</p> <p>Art. no. is specified in Required equipment on page 261.</p> <p>User instructions are enclosed with the tool.</p>
8	<p>Fit a <i>radial sealing</i> to the lower arm, if there is none left during removal of the arm.</p>	<p>Shown in the figure Components, lower arm shaft for robots with protection Foundry Plus on page 261.</p>
9	<p>Refit the <i>hexagon bolt</i> with a <i>spring washer</i> and a <i>shaft tap</i> through the hole in the lower arm shaft.</p>	
10	<p>Fit the <i>shaft for the sealing cover</i> onto the hexagon bolt and tighten the bolt with torque: 24 Nm.</p>	
11	<p>Check the <i>o-ring</i> in the sealing cover. Replace if damaged.</p>	
12	<p>Refit the <i>sealing cover</i> onto the shaft. Press it tightly against the radial sealing while tightening the set screws. Use locking liquid.</p>	

Continues on next page

	Action	Note/Illustration
13	Proceed with the refitting procedure of the lower arm, detailed in section Replacement of complete lower arm on page 250 .	

4 Repair

4.4.6 Securing the lower arm

4.4.6 Securing the lower arm

General

This section details how to secure the lower arm with a specific fixture prior to performing certain service activities to the robot.

Attachment points, robot

The special equipment used to secure the lower arm is fitted to the attachment points shown in the figure below.

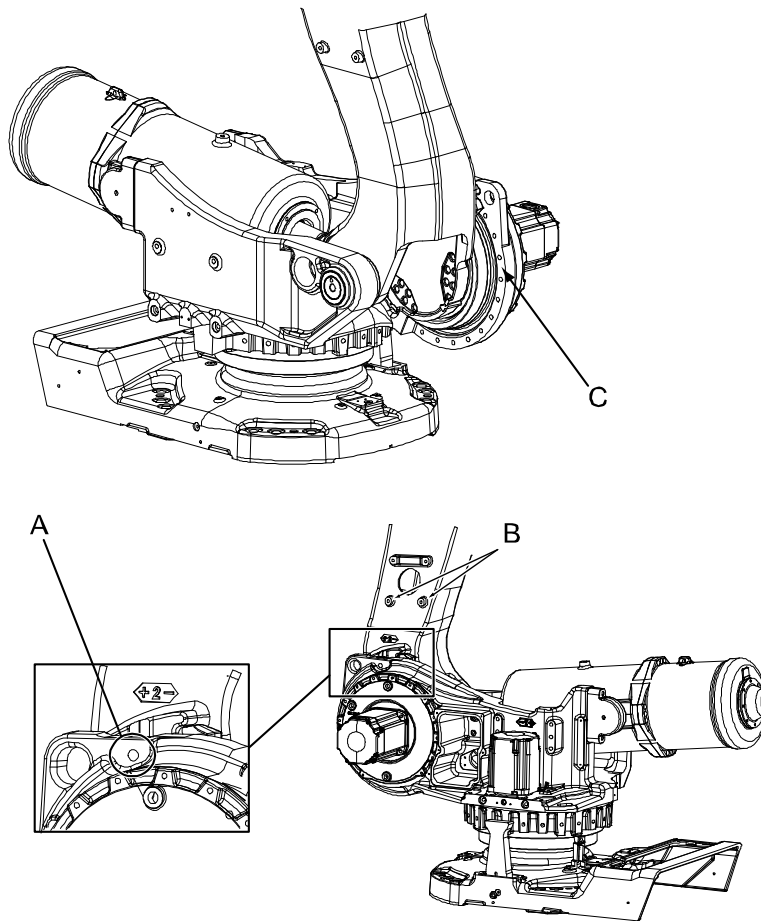

xx0300000608

A	Attachment hole, securing screw
B	Holes for M12 bolts
C	Holes for M16 bolts

Required equipment

Equipment, etc	Art. no.	Note
Fixture lower arm	3HAC020729-001	Includes the locking screw for securing the lower arm.

Continues on next page

Equipment, etc	Art. no.	Note
Standard toolkit	3HAC 15571-1	The contents are defined in section Standard tools on page 406 in part 2 of the Product manual.

Fixture, lower arm

The attachment bolts, locking screw, adjusters and ring nuts are attached to the fixture tool as shown in the figure below. Move them to the attachment points shown in the instruction.

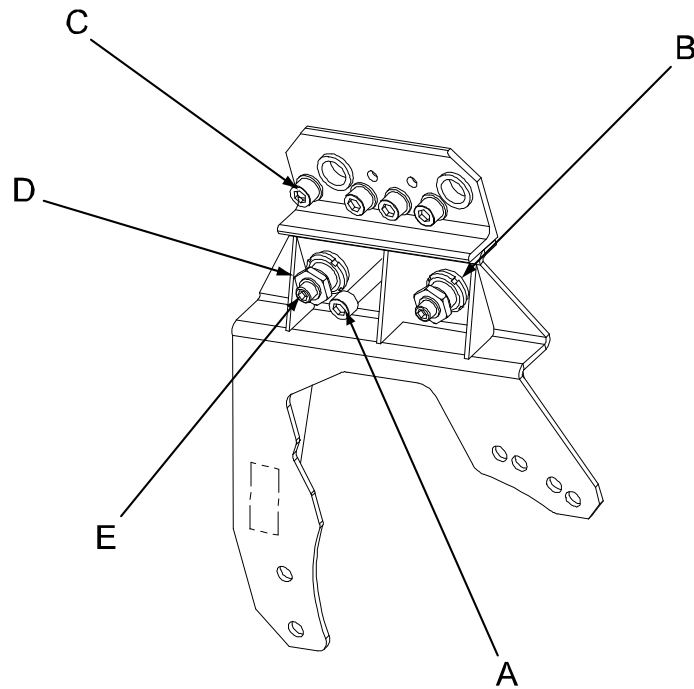

xx030000609

A	Locking screw
B	Adjusters, 2 pcs
C	M16 bolts, 4 pcs
D	Ring nuts, 2 pcs
E	M12 bolts and washers, 2 pcs

Continues on next page

4 Repair

4.4.6 Securing the lower arm

Continued

Securing the lower arm

The procedure below details how to secure the lower arm by fitting the fixture to the robot.

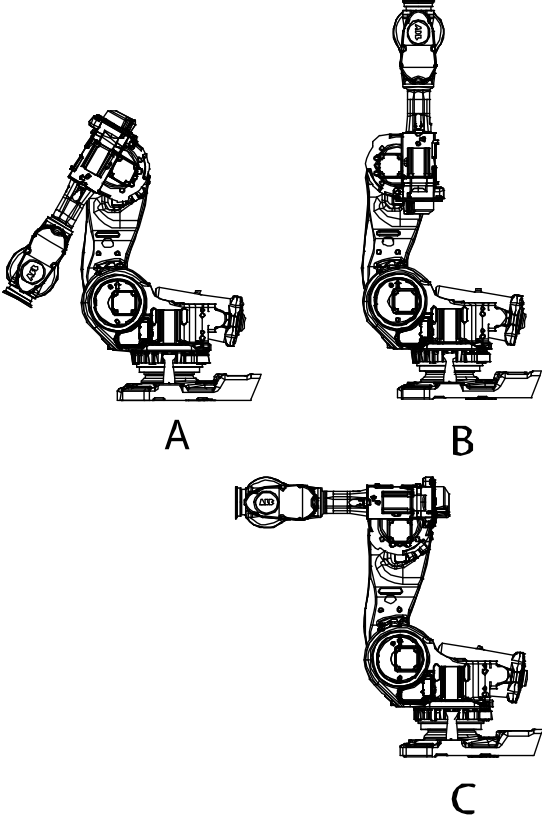
	Action	Note/Illustration
1	<p> DANGER</p> <p>Turn off all:</p> <ul style="list-style-type: none"> • electric power supply to the robot • hydraulic pressure supply to the robot • air pressure supply to the robot <p>Before entering the robot working area.</p>	
2	Remove any load or equipment fitted to the upper arm or turning disk.	
3	<p>Move the robot to the calibration position. The upper arm can be directed in three different ways, shown in the figure to the right.</p> <p>The lowered position, as in figure A, is recommended as it gives the least load on the tool.</p>	 <p style="text-align: center;">A B</p> <p style="text-align: right;">C</p> <p>xx0200000260</p>
4	<p>If the robot is fitted with moveable mechanical stops on axis 2 (not stock equipment), these must be removed at this point.</p> <p>The attachment holes of the mechanical stops are used to attach the fixture.</p>	

Continues on next page

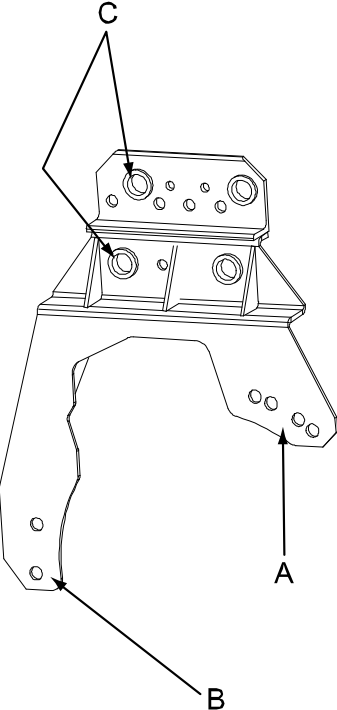
	Action	Note/Illustration
5	Remove the <i>locking screw</i> from the fixture, where it is attached.	Shown in the figure <i>Fixture, lower arm on page 269</i> . Art. no. of the fixture is specified in <i>Required equipment on page 268</i> .
6	Secure the lower arm to the frame by inserting the locking screw into a specific <i>attachment hole</i> through the frame, into the lower arm.	Shown in the figure <i>Attachment points, robot on page 268</i> .
7	<p>Fit the <i>fixture, lower arm</i> to the frame and the lower arm, according to following instruction:</p> <ol style="list-style-type: none"> 1 Fit the both adjusters in the correct holes and make sure that they are screwed back (C). 2 Align the fixture with the frame and lower arm. 3 Make sure the fixture is pressed tightly against the lower arm before securing with screws! 4 Fit and tighten the four M16 bolts in the attachment holes on the inside of the frame with tightening torque: 220 Nm (A). 5 Screw in the two adjusters until they rest against the flats on the lower arm. Tighten by hand. 6 Lock, using the two ring nuts. 7 Fit and tighten the two M12 bolts in the attachment holes on the lower arm with tightening torque: 91 Nm (C). 	<p>Art. no. is specified in <i>Required equipment on page 268</i>.</p> <p>Attachment holes on the frame and on the lower arm are shown in the figure <i>Attachment points, robot on page 268</i>!</p> <p>The adjusters, bolts and ring nuts are shown in the figure <i>Fixture, lower arm on page 269</i>.</p>  <p>xx0300000610</p> <ul style="list-style-type: none"> • A: Holes for M16 bolts. Choose the 2 suitable holes for current robot model. • B: Holes for M16 bolts. • C: Holes for M12 bolts (2 pcs), adjusters, ring nuts and washers. Choose the suitable holes for current robot model.
8	The lower arm is now secured and it is safe to remove the gearbox of axis 2, according to section <i>Removal, gearbox axis 2 on page 341</i> , provided that the balancing device is unloaded.	

4 Repair

4.5.1 Replacing the SMB unit

4.5 Frame and base

4.5.1 Replacing the SMB unit

Location of SMB unit

The SMB unit (SMB = serial measurement board) is located on the left hand side of the frame as shown in the figure.

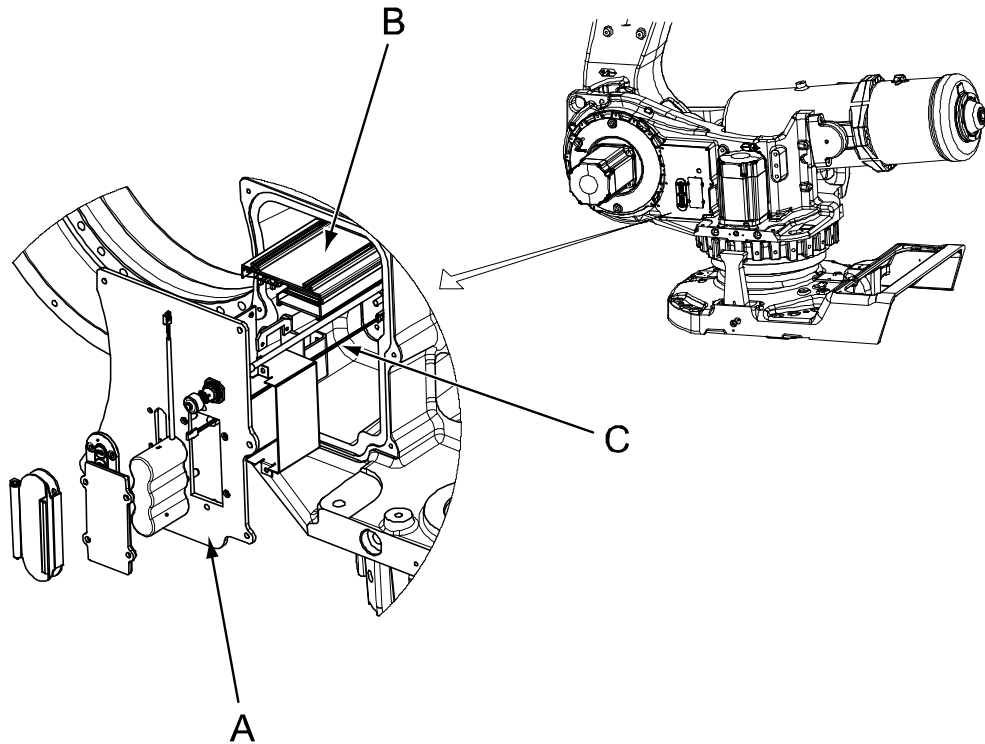

xx0300000557

A	SMB cover
B	SMB unit
C	Battery cable

Required equipment



Note

There are different variants of SMB units and batteries. The variant with the 3-pole battery contact has longer lifetime for the battery.

It is important that the SMB unit uses the correct battery. Make sure to order the correct spare parts. Do not replace the battery contact!



Equipment, etc.	Article number	Note
SMB unit	For spare part number, see: Spare part lists on page 397.	

Continues on next page

Equipment, etc.	Article number	Note
Standard toolkit	-	Content is defined in section Standard tools on page 406 .
Circuit diagram	-	See chapter Circuit diagram on page 411 .

Removing, SMB unit

Use this procedure to remove the SMB unit.

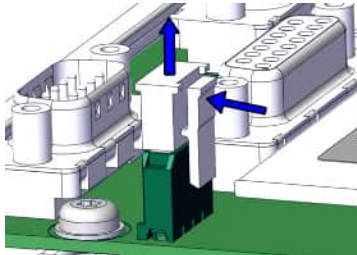
	Action	Note
1	Move the robot to the calibration position.	
2	 DANGER Turn off all: <ul style="list-style-type: none"> • electric power supply • hydraulic pressure supply • air pressure supply to the robot, before entering the robot working area.	
3	 ELECTROSTATIC DISCHARGE (ESD) The unit is sensitive to ESD. Before handling the unit read the safety information in section The unit is sensitive to ESD on page 54 .	
4	Remove the SMB cover by unscrewing its attachment screws.  CAUTION Clean cover from metal residues before opening. Metal residues can cause shortage on the boards which can result in hazardous failures.	Shown in the figure Location of SMB unit on page 272 .
5	Use caution and remove the connectors X8, X9 and X10 from the brake release board, if need of more space.	
6	Remove the nuts and washers from the guide pins that secure the board.	Shown in the figure Location of SMB unit on page 272 .
7	Use caution and disconnect the connectors from the SMB unit when pulling the board out.	Connectors R1.SMB1-3, R1.SMB4-6 and R2.SMB
8	Disconnect the battery cable by pressing down the upper lip of the R2.G connector to release the lock while pulling the connector upwards.	 xx1700000993

Continues on next page





4 Repair

4.5.1 Replacing the SMB unit

Continued

Refitting, SMB unit

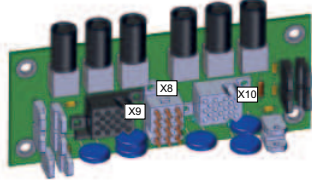
Use this procedure to refit the SMB unit.

	Action	Note
1	 <p>DANGER</p> <p>Turn off all:</p> <ul style="list-style-type: none"> • electric power supply • hydraulic pressure supply • air pressure supply <p>to the robot, before entering the robot working area.</p>	
2	 <p>ELECTROSTATIC DISCHARGE (ESD)</p> <p>The unit is sensitive to ESD. Before handling the unit read the safety information in section The unit is sensitive to ESD on page 54.</p>	
3	<p>Connect the <i>battery cable</i> to the SMB unit. Make sure the lock on the battery cable connector R2.G snaps into place during refitting.</p>	Shown in the figure Location of SMB unit on page 272 .
4	<p>Connect all connectors to the SMB board: R1.SMB1-3, R1.SMB4-6 and R2.SMB</p>	<p>Art. no. is specified in Required equipment on page 272.</p> <p>Shown in the figure Location of SMB unit on page 272.</p>
5	<p>Fit the <i>SMB unit</i> onto the <i>guide pins</i>.</p>	
6	<p>Secure the SMB unit to the pins with the nuts and washers.</p>	
7	<p>If disconnected, reconnect the connectors X8, X9 and X10 to the brake release board. Be careful not to damage the sockets or pins. Make sure the connector and its locking arms are snapped down properly.</p>	 <p>xx1700000978</p>
8	<p>Secure the <i>SMB cover</i> with its attachment screws.</p> <p>If cabling is used for 7th axis (option), refit the 7th axis connector to the SMB cover and tighten with 6 Nm.</p>	Shown in the figure Location of SMB unit on page 272 .
9	<p>Update the revolution counters.</p>	See Updating revolution counters on IRC5 robots on page 366 .
10	 <p>DANGER</p> <p>Make sure all safety requirements are met when performing the first test run. See Test run after installation, maintenance, or repair on page 108.</p>	

4.5.2 Replacing the brake release board

Location of brake release board

The brake release unit is located together with the SMB unit on the left hand side of the frame, right next to the gearbox, axis 2, as shown in figure below.

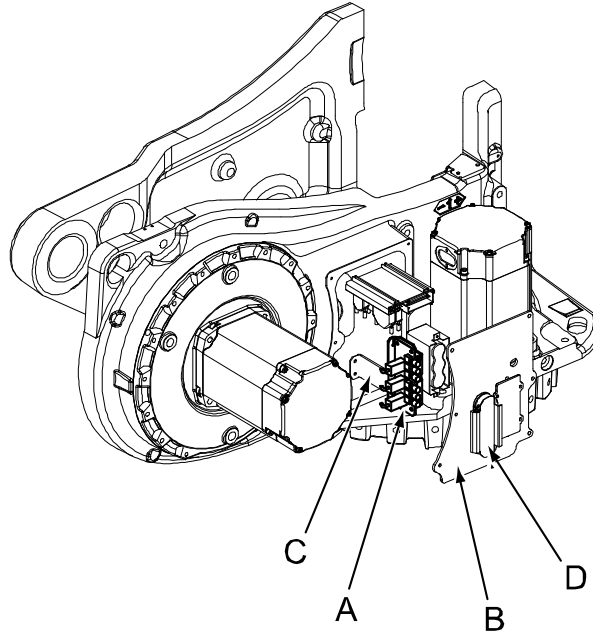

xx0300000558

A	Brake release unit
B	SMB cover
C	Bracket
D	Push button guard

Required equipment

Equipment, etc.	Article number	Note
Brake release board	3HAC065020-001	DSQC1050
Standard toolkit	-	Content is defined in section Standard tools on page 406 .
Other tools and procedures may be required. See references to these procedures in the step-by-step instructions below.		These procedures include references to the tools required.

Continues on next page



4 Repair

4.5.2 Replacing the brake release board

Continued

Removing, brake release board

Use this procedure to remove the brake release board.

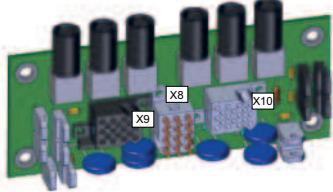
	Action	Note
1	 DANGER Turn off all: <ul style="list-style-type: none"> • electric power supply to the robot • hydraulic pressure supply to the robot • air pressure supply to the robot Before entering the robot working area.	
2	 ELECTROSTATIC DISCHARGE (ESD) The unit is sensitive to ESD. Before handling the unit read the safety information in section The unit is sensitive to ESD on page 54.	
3	Remove the push button guard from the SMB cover.	Shown in the figure Location of brake release board on page 275. The guard must be removed to ensure a correct refitting of the brake release board.
4	Open the SMB cover by unscrewing the attachment screws. Let the battery stay connected, to avoid the need of synchronization of the robot!  CAUTION Clean cover from metal residues before opening. Metal residues can cause shortage on the boards which can result in hazardous failures.	Shown in the figure Location of brake release board on page 275.
5	Take a picture or make notes of how the robot cabling is positioned in regard to the brake release board.	
6	Remove the complete brake release board (including brake release board and bracket) from the SMB recess, by removing its two attachment screws.	
7	Disconnect the connectors X8, X9 and X10 from the brake release board.	 <p>xx1700000978</p> Location of the brake release unit is shown in the figure Location of brake release board on page 275.

Continues on next page

	Action	Note
8	Remove the brake release board from the bracket by removing the four attachment screws.	

Refitting, brake release board

Use this procedure to refit the brake release board.

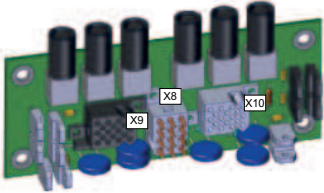
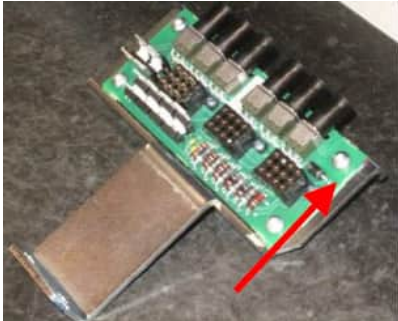

	Action	Note
1	 <p>ELECTROSTATIC DISCHARGE (ESD)</p> <p>The unit is sensitive to ESD. Before handling the unit read the safety information in section The unit is sensitive to ESD on page 54.</p>	
2	<p>Connect the connectors X8, X9 and X10 to the brake release board.</p> <p>Be careful not to damage the sockets or pins. Make sure the connector and its locking arms are snapped down properly.</p>	 <p>xx1700000978</p>
3	<p>Fasten the <i>brake release board</i> on the bracket with the attachment screws.</p> <p>Make sure the board is pushed forwards and positioned as straight as possible on the bracket when fastening with the attachment screws. The push buttons can otherwise get jammed when the SMB cover is refitted.</p>  <p>xx1700001153</p>	<p>Maximum tightening torque: 5 Nm.</p> <p>Shown in the figure Location of brake release board on page 275.</p> <p>Art. no. is specified in Required equipment on page 275.</p>
4	<p>Refit the complete brake release board (including brake release board and bracket) to the SMB recess with the two attachment screws.</p>	

Continues on next page

4 Repair

4.5.2 Replacing the brake release board

Continued

	Action	Note
5	<p>Verify that the robot cabling is positioned correctly, according to previously taken picture/notes.</p> <p> WARNING</p> <p>Screened cables must not get in contact with the brake release board after installation. Eliminate all risks of contact between screened cables and the brake release board.</p>	
6	<p>Refit the <i>SMB cover</i> with its attachment screws.</p>	<p>Shown in the figure Location of brake release board on page 275.</p>
7	<p> WARNING</p> <p>Before continuing any service work, follow the safety procedure in The brake release buttons may be jammed after service work on page 191.</p>	
8	<p>Refit the <i>push button guard</i> to the SMB cover.</p>	<p>Shown in the figure Location of brake release board on page 275.</p>
9	<p>Press the push buttons 1 to 6, one at a time, to make sure that the buttons are moving freely and do not stay in a locked position.</p>	
10	<p>If the battery has been disconnected the revolution counter must be updated.</p>	<p>Detailed in the Calibration chapter - section Updating revolution counters on IRC5 robots on page 366.</p>
11	<p> DANGER</p> <p>Make sure all safety requirements are met when performing the first test run. See Test run after installation, maintenance, or repair on page 108.</p>	

4.5.3 Replacement of spherical roller bearing, balancing device

Location of bearing

The bearing is located at the front ear of the balancing device, as shown in the figure below.

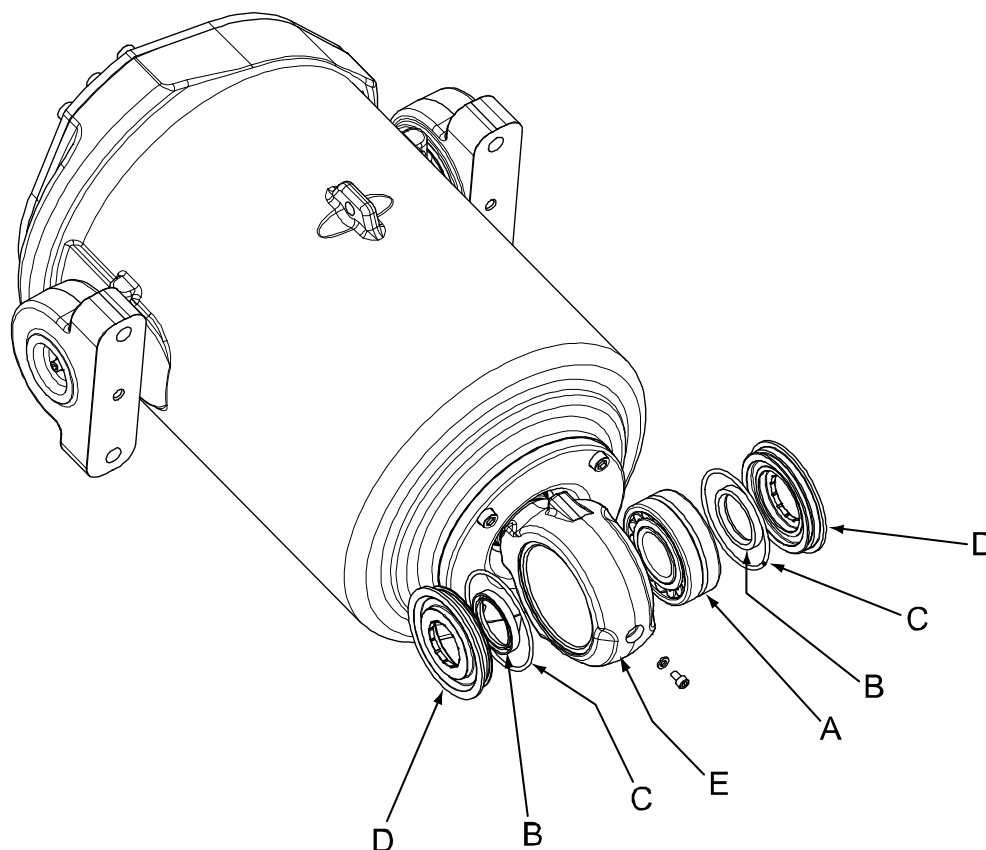

xx0500002249

A	Spherical roller bearing
B	Sealing ring
C	O-ring
D	Sealing spacer
E	Front ear of balancing device

Required equipment

Equipment	Spare part no.	Art. no.	Note
Spherical roller bearing	3HAA2167-17		
Sealing spacer	3HAC12988-1		2 pcs required.
O-ring	3HAB3772-76		2 pcs required.
Sealing ring	3HAC11581-6		2 pcs required.
Grease		3HAC042536-001	For lubrication of the components.

Continues on next page

4 Repair

4.5.3 Replacement of spherical roller bearing, balancing device

Continued

Equipment	Spare part no.	Art. no.	Note
Toolkit		3HAC15943-1	The tools in the set are shown in the section Tool set.
Other tools and procedures may be required. See references to these procedures in the step-by-step instructions below.			These procedures include references to the tools required.

Tool set

The parts of the tool set for replacing the spherical roller bearing are shown in the figure.

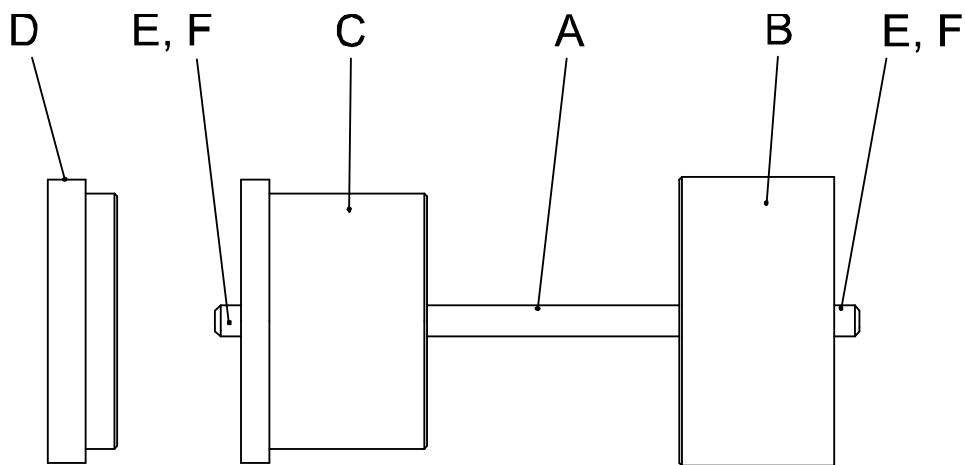

xx0500002259

A	Threaded bar
B	Dolly
C	Press tool for removal of bearing
D	Press tool for refitting of bearing
E	Hexagon nut M12 (2pcs)
F	Plain washer 13x24x2,5 (2pcs)

Removal, spherical roller bearing

Use this procedure to remove the spherical roller bearing from the balancing device front ear.

Action	Note
<p>1</p> <p> DANGER</p> <p>Turn off all:</p> <ul style="list-style-type: none"> • electric power supply to the robot • hydraulic pressure supply to the robot • air pressure supply to the robot <p>Before entering the robot working area.</p>	

Continues on next page



4.5.3 Replacement of spherical roller bearing, balancing device

Continued

	Action	Note
2	Remove the balancing device from the robot.	Detailed in section Replacing the balancing device on page 282 .
3	Remove the both <i>sealing spacers</i> with a screwdriver or any equal tool.	Shown in the figure Location of bearing on page 279 .
4	Insert the threaded bar through the bearing.	
5	Fit the press tool and dolly to the threaded bar. Secure with the nut and washer at each end.	A Threaded bar 3HAC15945-1 B Dolly 3HAC15948-1 C Press tool 3HAC15941-1
6	Press out the bearing from the front ear.	

Refitting, spherical roller bearing

Use this procedure to refit the spherical roller bearing to the balancing device front ear.

	Action	Note
1	 DANGER Turn off all: <ul style="list-style-type: none"> • electric power supply to the robot • hydraulic pressure supply to the robot • air pressure supply to the robot Before entering the robot working area.	
2	Grease the inside walls of the front ear.	
3	Press in the bearing properly inside the ear.	
4	Apply grease to the new <i>sealing rings</i> and <i>o-rings</i> and fit one of each to the new <i>sealing spacers</i> . Also, grease the sealing spacers.	Spare part no:s are specified in Required equipment on page 279 .
5	Refit the balancing device to the robot.	Detailed in section Refitting, balancing device on page 289 .
6	Lubricate the spherical roller bearing in the ear.  Note The balancing device must be mounted on the robot when lubrication is performed!	Detailed in section Lubrication of spherical roller bearing, balancing device on page 177
7	Make sure no incorrect leakage occurs. It could indicate damaged o-rings.	This is detailed in section Check for leakage on page 135 .
8	 DANGER Make sure all safety requirements are met when performing the first test run. See Test run after installation, maintenance, or repair on page 108 .	

4 Repair

4.5.4.1 Replacing the balancing device

4.5.4 Replacement of balancing device

4.5.4.1 Replacing the balancing device

Location of balancing device

The balancing device is located on rear top of the frame as shown in the figure below.

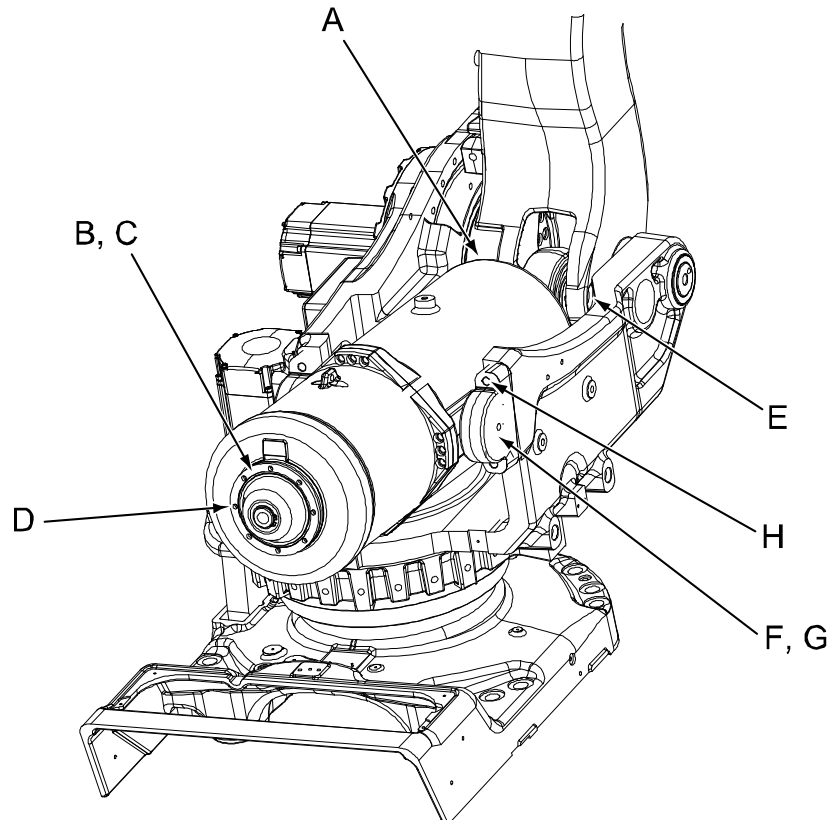

xx0300000533

A	Balancing device
B	Rear cover
C	Support shaft inside
D	Attachment screws, rear cover
E	Balancing device shaft, including securing screw
F	Bearing attachment
G	Parallel pin (inside bearing attachment)
H	Attachment screws, bearing attachments

Continues on next page

Attachment points, balancing device

The attachment points for the lifting tools etc. are located as shown in the figure below.

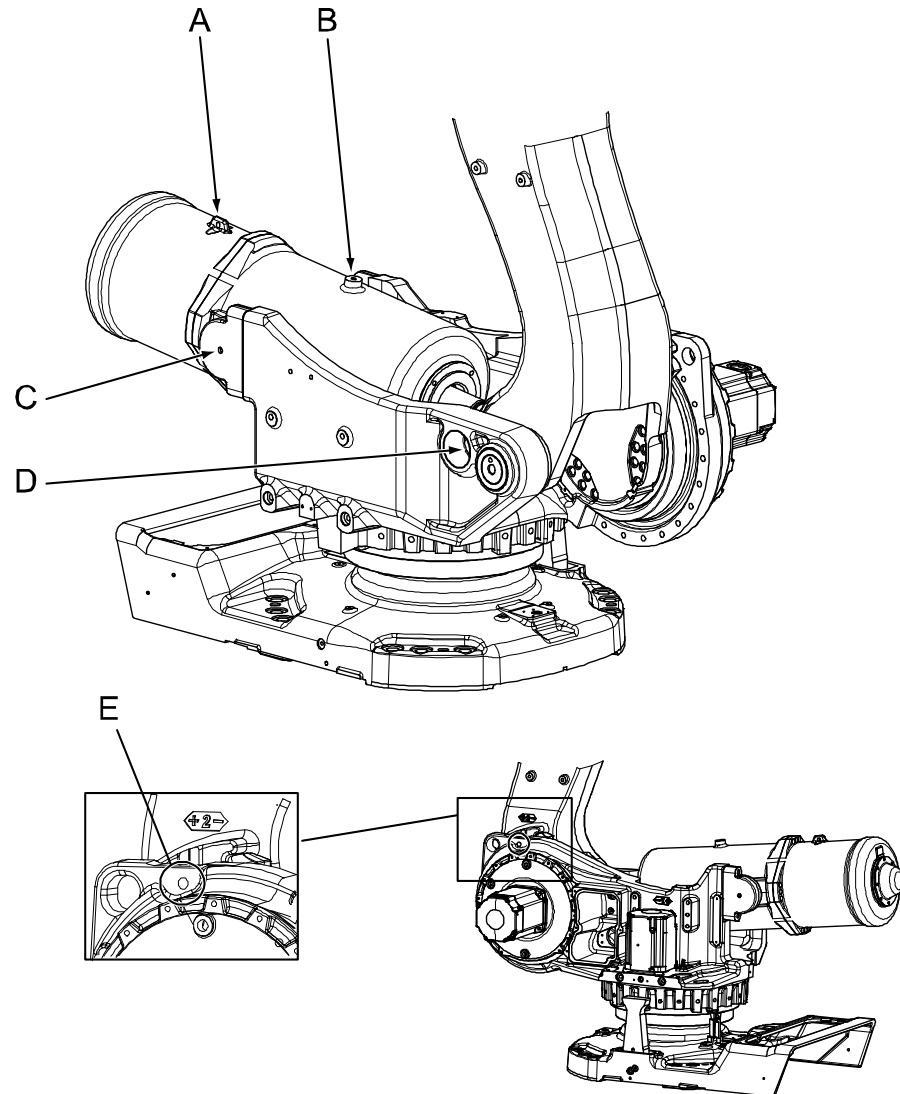

xx0300000481

B	Lifting eye for the lifting equipment
C	Securing screw attachment hole, secures the bearing attachment to the balancing device (remove the protection plug)
D	Hole in the frame to access the balancing device shaft with the puller/press tool
E	Locking screw attachment hole, secures the lower arm to the frame

Required equipment

Equipment	Spare part no.	Art. no.	Note
Balancing device	See <i>Spare part lists on page 397</i> .		Includes balancing device 3HAC020040-001! Includes o-rings 3HAB3772-44.

Continues on next page

4 Repair

4.5.4.1 Replacing the balancing device

Continued

Equipment	Spare part no.	Art. no.	Note
O-ring		3HAB3772-44	3 pcs, to be replaced if damaged!
Locking screw		3HAA1001-266	M16 x 60 For securing the lower arm.
Securing screw		9ADA183-66	M12 x 35, 2 pcs required For securing the bearing attachments to the balancing device when lifting.
Bearing grease		3HAC042536-001	For lubricating the o-rings and the shaft.
Grease		3HAA1001-294	80 ml, Tribol GR 100-0-PD For lubrication of spherical roller bearing in ear, in case of new balancing device.
Locking liquid		-	Loctite 243 To apply to the securing screw in the shaft.
Locking liquid		-	Loctite 577 Used to secure the attachment screws of the rear cover at the end of the balancing device.
Grease pump		-	To lubricate spherical roller bearing.
Guide pins M16 x 300		3HAC13120-5	Always use guide pins in pairs!
Lifting eye M12		3HAC14457-3	
Shackle, balancing device		3HAC 020997-1	
Lifting tool (chain)		3HAC15556-1	
Press equipment, balancing device		3HAC074411-001	For unloading the balancing device. User instructions are enclosed with the tool.
Adapter for Press equipment, balancing device		3HAC078221-001	To be used with 3HAC074411-001 for balancing devices from 2002 and older.
Press equipment, balancing device shaft		3HAC076202-001	For replacing the balancing device shaft. User instructions are enclosed with the tool.
Hydraulic cylinder		3HAC11731-1	To be used with the press and puller tools. See technical specifications in the user instructions for the press equipment.



Continues on next page

Equipment	Spare part no.	Art. no.	Note
Hydraulic pump 80 MPa		3HAC13086-1	To be used with the hydraulic cylinder. See technical specifications in the user instructions for the press equipment.
Hydraulic valve with hose		3HAC022643-001	
Standard toolkit		-	Content is defined in section Standard tools on page 406 .
Other tools and procedures may be required. See references to these procedures in the step-by-step instructions below.			These procedures include references to the tools required.

Removal, balancing device

The procedures below detail how to remove the balancing device.

Preparations before removing the balancing device

	Action	Note
1	Move the lower arm to a position close to the calibration position.	
2	 DANGER Turn off all: <ul style="list-style-type: none"> • electric power supply to the robot • hydraulic pressure supply to the robot • air pressure supply to the robot Before entering the robot working area.	
3	Secure the lower arm to the frame by inserting the <i>locking screw</i> into the attachment hole in the frame.	Attachment hole for the locking screw is shown in the figure Attachment points, balancing device on page 283 . Art. no. is specified in Required equipment on page 283 !
4	 CAUTION The balancing device weighs 407 kg! All lifting equipment used must be sized accordingly!	
5	Apply the <i>lifting eye</i> and the <i>shackle</i> to the attachments on the balancing device and raise to unload the weight.	Art. no. is specified in Required equipment on page 283 ! Attachments are shown in the figure Attachment points, balancing device on page 283 .



Continues on next page

4 Repair

4.5.4.1 Replacing the balancing device

Continued

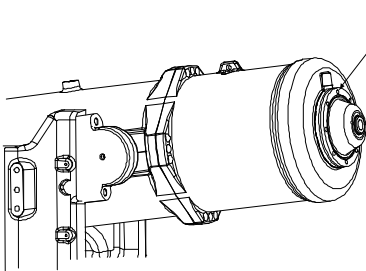
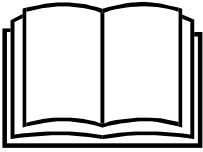

Unloading the balancing device

	Action	Note
1	<p>Remove the <i>rear cover</i> of the balancing device, by unscrewing the <i>attachment screws</i>.</p>  <p>DANGER</p> <p>DO NOT! remove any other screws than the rear cover attachment screws.</p>	 <p>xx0300000606</p> <ul style="list-style-type: none"> • E: Rear cover attachment screws, 8 pcs
2	<p>Remove</p> <ul style="list-style-type: none"> • the o-ring from the balancing device end. • the support shaft, including the damper, from the balancing device. • the remaining o-ring from the balancing device end. 	
3	<p>Unload the balancing device with the <i>press equipment</i> in order to make the piston rod and front ear adjustable when pulling the shaft out.</p>  <p>xx0900000813</p> <p>Go to the user instructions enclosed with the press tool.</p>  <p>DANGER</p> <p>Handling the tool incorrectly will cause serious injury.</p> <p>Read and follow enclosed user instructions for the tool.</p>	<p>Art. no. is specified in Required equipment on page 283!</p> <p>User instructions are enclosed with the tool.</p>

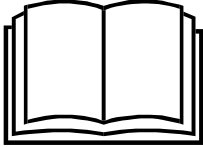

Removing the balancing device shaft

	Action	Note
1	<p>Remove the securing screw from the <i>balancing device shaft</i>.</p>	<p>Shown in the figure Location of balancing device on page 282!</p>

Continues on next page

	Action	Note
2	<p>Pull the shaft out using the <i>press equipment, balancing device shaft</i>, according to user instructions enclosed with the equipment.</p>  <p>xx0900000813</p> <p>Go to the user instructions enclosed with the press tool.</p>  DANGER Handling the tool incorrectly will cause serious injury. Read and follow enclosed user instructions for the tool.	<p>Art. no. is specified in Required equipment on page 283! User instructions are enclosed with the tool.</p>  Note Make sure to keep the balancing device unloaded.

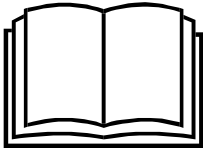
Restoring the balancing device



	Action	Note
1	<p>Restore the balancing device according to instructions for the <i>press equipment</i>.</p>  <p>xx0900000813</p> <p>Go to the user instructions enclosed with the press tool.</p>  DANGER Handling the tool incorrectly will cause serious injury. Read and follow enclosed user instructions for the tool.	<p>Art. no. is specified in Required equipment on page 283! User instructions are enclosed with the tool.</p>
2	<p>Lubricate and refit the o-ring at the end of the balancing device.</p>	<p>Make sure the o-ring is seated properly! Replace if damaged.</p>
3	<p>Make sure the damper is properly fitted to the support shaft and refit them both to the balancing device.</p>	
4	<p>Lubricate and refit the o-ring on the support shaft.</p>	<p>Make sure the o-ring is seated properly! Replace if damaged.</p>

Continues on next page

4 Repair

4.5.4.1 Replacing the balancing device

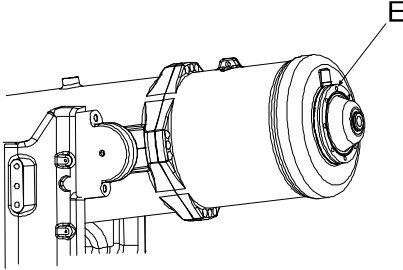
Continued

	Action	Note
5	Refit the rear cover to the balancing device with its attachment screws, using locking liquid. Apply sikaflex 521FX on the cover.	 <p>xx0300000606</p> <ul style="list-style-type: none"> E: 8 pcs: M10x45, tightening torque: 50 Nm. <p>Locking liquid is specified in Required equipment on page 283.</p>
6	 <p>DANGER</p> <p>The rear cover of the balancing device is a safety device for the piston rod during operation! Make sure the cover is properly secured before commissioning of the robot!</p>	

Removing the balancing device



	Action	Note
1	Secure the two <i>bearing attachments</i> to the balancing device by replacing the protection plug on the outside of each attachment, with <i>securing screws</i> . The protection plugs must be refitted after refitting the balancing device, do not loose them!	Shown in the figure Attachment points, balancing device on page 283 ! Dimensions for the securing screws are specified in Required equipment on page 283 .
2	Remove the two <i>bearing attachments</i> from the frame by unscrewing their four <i>attachment screws</i> .	Shown in the figure Location of balancing device on page 282 ! Make sure the parallel pins inside are not lost!
3	Fit two <i>guide pins</i> through the upper holes of the bearing attachments, to the frame.	Art. no. is specified in Required equipment on page 283 !
4	Lift the balancing device gently backwards to a secure area, allowing the bearing attachments to slide on the guide pins.	 <p>Note</p> <p>Make sure not to burden the guide pins with the weight of the balancing device!</p>

Continues on next page

Refitting, balancing device

The procedures below detail how to refit the balancing device.

Refitting the balancing device

	Action	Note
1	 DANGER Turn off all: <ul style="list-style-type: none"> • electric power supply to the robot • hydraulic pressure supply to the robot • air pressure supply to the robot Before entering the robot working area.	
2	Secure the lower arm to the frame by inserting the <i>locking screw</i> into the attachment hole in the frame.	Art. no. is specified in Required equipment on page 283! Attachment hole is shown in the figure Attachment points, balancing device on page 283.
3	Secure the <i>bearing attachments</i> to the balancing device with <i>securing screws</i> .	Shown in the figure Attachment points, balancing device on page 283! Dimension of the securing screws is specified in Required equipment on page 283.
4	Refit the two <i>parallel pins</i> in the frame.	Shown in the figure Location of balancing device on page 282!
5	Fit two <i>guide pins</i> to the upper holes in the frame, where the bearing attachments are to be attached.	
6	Fit the <i>lifting eye</i> and the <i>shackle</i> to the attachment points on the balancing device.	Art. no. is specified in Required equipment on page 283! Attachments are shown in the figure Attachment points, balancing device on page 283.
7	 CAUTION The balancing device weighs 407 kg! All lifting equipment used must be sized accordingly!	
8	Lift the balancing device and bring it forward, gliding the bearing attachments on to the guide pins.	 Note Make sure not to burden the guide pins with the weight of the balancing device!
9	Remove the guide pins.	

Continues on next page



4 Repair

4.5.4.1 Replacing the balancing device

Continued



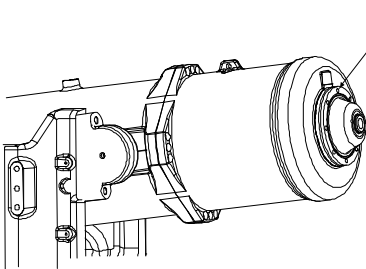
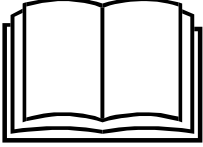

	Action	Note
10	Secure the rear of the balancing device by fastening the two bearing attachments to the frame with their four <i>attachment screws</i> .	Shown in the figure Location of balancing device on page 282! 4 pcs, M16x70, 12.9 quality UN-BRAKO, tightening torque: 300 Nm. Reused screws may be used, providing they are lubricated as detailed in section Screw joints on page 402 before fitting.
11	Remove the screws from outside of the bearing attachments and refit the protection plugs.	
12	Raise the balancing device to a position where the balancing device shaft may be inserted through the piston shaft front eye.	

Unloading the balancing device

	Action	Note
1	<p>Remove the <i>rear cover</i> of the balancing device, by unscrewing the <i>attachment screws</i>.</p>  <p>DANGER</p> <p>DO NOT! remove any other screws than the rear cover attachment screws.</p>	 <p>xx0300000606</p> <ul style="list-style-type: none"> E: Rear cover attachment screws, 8 pcs
2	<p>Remove</p> <ul style="list-style-type: none"> the o-ring from the balancing device end. the support shaft, including the damper, from the balancing device. the remaining o-ring from the balancing device end. 	
3	<p>Unload the balancing device with the <i>press equipment</i> in order to make the piston rod and front ear adjustable when pulling the shaft out.</p>  <p>xx0900000813</p> <p>Go to the user instructions enclosed with the press tool.</p>  <p>DANGER</p> <p>Handling the tool incorrectly will cause serious injury.</p> <p>Read and follow enclosed user instructions for the tool.</p>	<p>Art. no. is specified in Required equipment on page 283!</p> <p>User instructions are enclosed with the tool.</p>

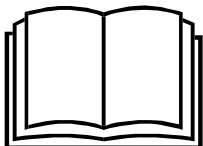
Continues on next page

Refitting the balancing device shaft

	Action	Note
1	Lubricate the shaft with grease.	Art. no. is specified in Required equipment on page 283!
2	<p>Fit the shaft to the piston shaft front eye through the hole in the frame, using the <i>press equipment, balancing device shaft</i>, according to user instructions enclosed with the equipment.</p>  <p>xx0900000813</p> <p>Go to the user instructions enclosed with the press tool.</p> <p> DANGER</p> <p>Handling the tool incorrectly will cause serious injury. Read and follow enclosed user instructions for the tool.</p>	<p>Art. no. is specified in Required equipment on page 283! User instructions are enclosed with the tool.</p> <p> Note</p> <p>Make sure to keep the balancing device unloaded.</p> <p> Note</p> <p>Make sure the shaft is pressed all the way to the bottom.</p>
3	Refit the securing screw into the shaft using <i>locking liquid</i> .	M16 x 180, tightening torque: 120 Nm. Locking liquid is specified in Required equipment on page 283!
4	Lubricate the spherical roller bearing through the lubrication nipple in the ear with <i>grease</i> , approximately 5 grams.	Art. no. and amount are specified in Required equipment on page 283! Lubrication is further detailed in section Lubrication of spherical roller bearing, balancing device on page 177 .
5	Clean the area from any excessive grease.	





Continues on next page

4 Repair

4.5.4.1 Replacing the balancing device

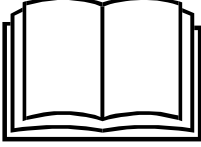

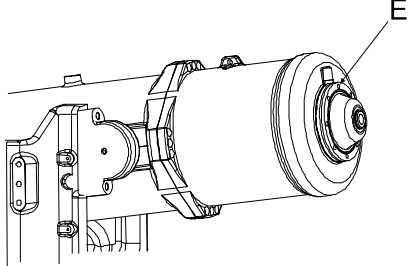
Continued

Restoring the balancing device

	Action	Note
1	<p>Restore the balancing device according to instructions for the <i>press equipment</i>.</p>  <p>xx0900000813</p> <p>Go to the user instructions enclosed with the press tool.</p> <p> DANGER</p> <p>Handling the tool incorrectly will cause serious injury.</p> <p>Read and follow enclosed user instructions for the tool.</p>	<p>Art. no. is specified in <i>Required equipment on page 283!</i></p> <p>User instructions are enclosed with the tool.</p>
2	<p>Lubricate and refit the o-ring at the end of the balancing device.</p>	<p>Make sure the o-ring is seated properly! Replace if damaged.</p>
3	<p>Make sure the damper is properly fitted to the support shaft and refit them both to the balancing device.</p>	
4	<p>Lubricate and refit the o-ring on the support shaft.</p>	<p>Make sure the o-ring is seated properly! Replace if damaged.</p>
5	<p>Refit the rear cover to the balancing device with its attachment screws, using locking liquid. Apply sikaflex 521FX on the cover.</p>	 <p>xx0300000606</p> <ul style="list-style-type: none"> E: 8 pcs: M10x45, tightening torque: 50 Nm. <p>Locking liquid is specified in <i>Required equipment on page 283.</i></p>
6	<p> DANGER</p> <p>The rear cover of the balancing device is a safety device for the piston rod during operation! Make sure the cover is properly secured before commissioning of the robot!</p>	

Continues on next page

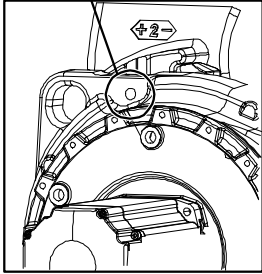
Concluding procedure

	Action	Note
1	Remove the locking screw that secures the lower arm to the frame.	<p>A</p>  <p>xx0300000484</p> <p>Attachment hole for the securing screw.</p>
2	 <p>DANGER</p> <p>Make sure all safety requirements are met when performing the first test run. See Test run after installation, maintenance, or repair on page 108.</p>	

4 Repair

4.6.1 Replacement of motor, axis 1

4.6 Motors

4.6.1 Replacement of motor, axis 1



Note

This procedure requires calibration of the robot.

The robot is calibrated by either Calibration Pendulum or Axis Calibration at factory. Always use the same calibration method as used at the factory.

Information about valid calibration method is found on the calibration label or in the calibration menu on the FlexPendant.

Location of motor

The motor axis 1 is located on the left hand side of the robot as shown in the figure below.

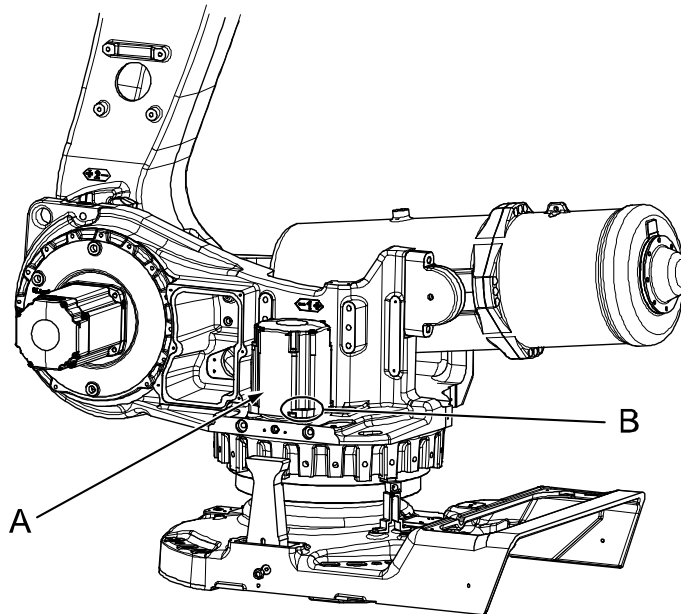

xx0300000499

A	Motor, axis 1
B	Motor attachment screws and washers

Required equipment

Equipment, etc.	Spare part no.	Art. no.	Note
Motor including pinion	See Spare part lists on page 397 .		Includes <ul style="list-style-type: none">• motor• pinion• o-ring 21522012-430.
O-ring	21522012-430		Must be replaced when reassembling the motor.

Continues on next page

Equipment, etc.	Spare part no.	Art. no.	Note
Mobilux EP 2	-	-	Used to lubricate the motor clutch.
Grease		3HAC042536-001	Used to lubricate the o-ring.
Removal tool, motor M12x		3HAC14631-1	Always use the removal tools in pairs!
Lifting tool, motor ax 1, 4, 5		3HAC14459-1	
Power supply		-	24 VDC, max. 1,5 A For releasing the brakes.
Standard toolkit		-	Content is defined in section Standard tools on page 406 .
Calibration tool box, Axis Calibration		3HAC055412-001	Delivered as a set of calibration tools. Required if Axis Calibration is the valid calibration method for the robot.
Other tools and procedures may be required. See references to these procedures in the step-by-step instructions below.			These procedures include references to the tools required.
Circuit diagram			See chapter Circuit diagram on page 411 .

Deciding calibration routine

Decide which calibration routine to be used, based on the information in the table. Depending on which routine is chosen, action might be required prior to beginning the repair work of the robot, see the table.

	Action	Note
1	<p>Decide which calibration routine to use for calibrating the robot.</p> <ul style="list-style-type: none"> Reference calibration. External cable packages (DressPack) and tools can stay fitted on the robot. Fine calibration. All external cable packages (DressPack) and tools must be removed from the robot. 	
	<p>If the robot is to be calibrated with reference calibration:</p> <p>Find previous reference values for the axis or create new reference values. These values are to be used after the repair procedure is completed, for calibration of the robot.</p> <p>If no previous reference values exist, and no new reference values can be created, then reference calibration is not possible.</p>	<p>Follow the instructions given in the reference calibration routine on the FlexPendant to create reference values.</p> <p>Creating new values requires possibility to move the robot.</p> <p>Read more about reference calibration for Axis Calibration in Reference calibration routine on page 373.</p>

Continues on next page

4 Repair





4.6.1 Replacement of motor, axis 1

Continued

Action	Note
<p>If the robot is to be calibrated with fine calibration: Remove all external cable packages (DressPack) and tools from the robot.</p>	

Removal, motor axis 1

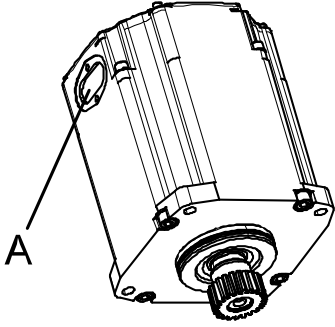
The procedure below details how to remove motor, axis 1.



Action	Note
1	Decide which calibration routine to use, and take actions accordingly prior to beginning the repair procedure.
2	<p> DANGER</p> <p>Turn off all:</p> <ul style="list-style-type: none"> • electric power supply to the robot • hydraulic pressure supply to the robot • air pressure supply to the robot <p>Before entering the robot working area.</p>
3	Remove the cover for connector access on top of the motor by unscrewing its four attachment screws.
4	<p>Remove the cable gland cover at the cable exit by unscrewing its two attachment screws.</p> <p> Note</p> <p>Make sure the gasket is not damaged!</p> <div style="text-align: right;">  <p>xx0200000199</p> <ul style="list-style-type: none"> • A: Cable gland cover </div>
5	Disconnect all connectors beneath the motor cover.
6	Apply <i>lifting tool, motor axis 1, 4, 5</i> to the motor. Art. no. is specified in Required equipment on page 294 .
7	In order to release the brakes, connect the 24 VDC power supply. Connect to connector R2.MP1 <ul style="list-style-type: none"> • +: pin 2 • -: pin 5
8	Remove the motor by unscrewing its four <i>attachment screws</i> and plain washers. Shown in the figure Location of motor on page 294 .
9	<p> CAUTION</p> <p>The motor weighs 25 kg! All lifting equipment used must be sized accordingly!</p>
10	Lift the motor to get the pinion away from the gear and disconnect the brake release voltage.

Continues on next page

	Action	Note
11	Remove the motor by gently lifting it straight up.	

Refitting, motor axis 1

The procedure below details how to refit motor, axis 1.

	Action	Note
1	 DANGER Turn off all: <ul style="list-style-type: none"> • electric power supply to the robot • hydraulic pressure supply to the robot • air pressure supply to the robot Before entering the robot working area.	
2	Make sure the <i>o-ring</i> on the circumference of the motor is seated properly. Lightly lubricate the <i>o-ring</i> with <i>grease</i> .	Art no. is specified in Required equipment on page 294 .
3	 CAUTION The motor weighs 25 kg! All lifting equipment used must be sized accordingly!	
4	Apply the <i>lifting tool, motor axis 1, 4, 5</i> to the motor.	Art no. is specified in Required equipment on page 294 .
5	In order to release the brake, connect the 24 VDC power supply.	Connect to connector R2.MP1 <ul style="list-style-type: none"> • +: pin 2 • -: pin 5
6	Fit the motor, making sure the motor pinion is properly mated to gearbox of axis 1.	Make sure the motor is turned the correct way, that is connection of motorcable forwards. . Make sure the motor pinion does not get damaged!
7	Fit the clutch on the pinion on the motor.	
8	Secure the motor with its four attachment screws and plain washers.	M10 x 40, tightening torque: 50 Nm.
9	Disconnect the brake release voltage.	
10	Reconnect all connectors beneath the motor cover.	
11	Refit the cable gland cover at the cable exit with its two attachment screws.	Make sure the cover is tightly sealed!
12	Refit the motor cover with its four attachment screws.	Make sure the cover is tightly sealed!
13	Recalibrate the robot!	Axis Calibration is described in Calibrating with Axis Calibration method on page 372 . General calibration information is included in section Calibration on page 359 .

Continues on next page

4 Repair

4.6.1 Replacement of motor, axis 1

Continued

	Action	Note
14	 DANGER Make sure all safety requirements are met when performing the first test run. See Test run after installation, maintenance, or repair on page 108 .	

4.6.2 Replacement of motor axis 2

Location of motor

The motor, axis 2, is located on the left-hand side of the robot as shown in the figure below.

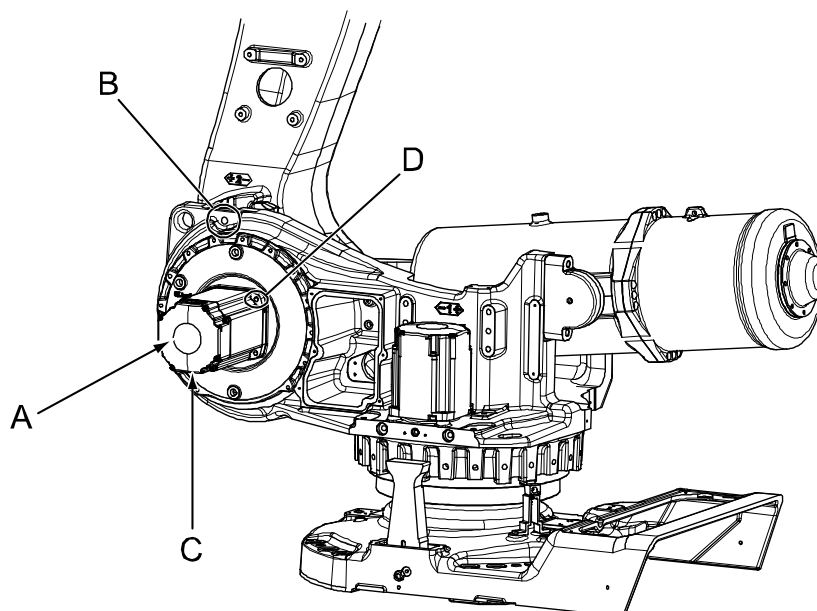

xx0300000500

A	Motor axis 2
B	Hole for lock screw
C	Cable gland cover (located on the lower side of the motor)
D	Motor attachment holes (4 pcs)

Required equipment

Equipment, etc.	Spare part no.	Art. no.	Note
Motor including pinion	See Spare part lists on page 397 .		Includes <ul style="list-style-type: none"> • motor • pinion • o-ring 2152 2012-430
O-ring	21522012-430		Must be replaced when re-assembling motor!
Grease		3HAC042536-001	For lubricating the o-ring.
Locking screw		3HAA1001-266	M16 x 60 For securing the lower arm.
Removal tool, motor M12x		3HAC14631-1	Always use the removal tools in pairs!
Guide pins M10 x 150		3HAC15521-2	For guiding the motor. Guides are to be used in pairs!

Continues on next page

4 Repair

4.6.2 Replacement of motor axis 2

Continued

Equipment, etc.	Spare part no.	Art. no.	Note
Lifting tool, motor ax 2, 3, 4		3HAC15534-1	
Extension bar, 300 mm for bits 1/2"		3HAC12342-1	
Power supply		-	24 VDC, 1.5 A For releasing the brakes.
Rotation tool		3HAC17105-1	Used to rotate the motor pinion when mating it to the gear when brakes are released with 24VDC power supply.
Standard toolkit		-	Content is defined in section Standard tools on page 406 .
Calibration tool box, Axis Calibration		3HAC055412-001	Delivered as a set of calibration tools. Required if Axis Calibration is the valid calibration method for the robot.
Other tools and procedures may be required. See references to these procedures in the step-by-step instructions below.			These procedures include references to the tools required.
Circuit diagram			See chapter Circuit diagram on page 411 .

Deciding calibration routine

Decide which calibration routine to be used, based on the information in the table. Depending on which routine is chosen, action might be required prior to beginning the repair work of the robot, see the table.



	Action	Note
1	<p>Decide which calibration routine to use for calibrating the robot.</p> <ul style="list-style-type: none"> Reference calibration. External cable packages (DressPack) and tools can stay fitted on the robot. Fine calibration. All external cable packages (DressPack) and tools must be removed from the robot. 	
	<p>If the robot is to be calibrated with reference calibration: Find previous reference values for the axis or create new reference values. These values are to be used after the repair procedure is completed, for calibration of the robot. If no previous reference values exist, and no new reference values can be created, then reference calibration is not possible.</p>	<p>Follow the instructions given in the reference calibration routine on the FlexPendant to create reference values. Creating new values requires possibility to move the robot. Read more about reference calibration for Axis Calibration in Reference calibration routine on page 373.</p>

Continues on next page

Action	Note
<p>If the robot is to be calibrated with fine calibration:</p> <p>Remove all external cable packages (DressPack) and tools from the robot.</p>	

Removal, motor

The procedure below details how to remove the motor, axis 2.

Action	Note	
1	Decide which calibration routine to use, and take actions accordingly prior to beginning the repair procedure.	
2	Move the robot to a position close enough to its calibration position, to allow the lock screw to be inserted into the <i>hole for lock screw</i> .	Shown in the figure Location of motor on page 299 .
3	 DANGER Turn off all: <ul style="list-style-type: none"> • electric power supply to the robot • hydraulic pressure supply to the robot • air pressure supply to the robot Before entering the robot working area.	
4	Lock the lower arm by inserting the <i>lock screw</i> into the hole.	Art. no. and dimension is specified in Required equipment on page 299 .
5	Drain the oil from gearbox, axis 2.	Detailed in the section Changing oil, axis-2 gearbox on page 158 .
6	Remove the cover on top of the motor by unscrewing its four attachment screws.	
7	Remove the <i>cable gland cover</i> at the cable exit by unscrewing its two attachment screws.	Shown in the figure Location of motor on page 299 . Make sure the gasket is not damaged!
8	Disconnect all connectors beneath the motor cover.	
9	 DANGER Secure the weight of the lower arm properly before releasing the brakes of motor, axis 2! When releasing the holding brakes of the motor, the lower arm will be movable and may fall down!	Use the lock screw to lock the lower arm, as detailed above!

Continues on next page

4 Repair

4.6.2 Replacement of motor axis 2

Continued





	Action	Note
10	In order to release the brake, connect the 24 VDC power supply.	Connect to connector R2.MP2 <ul style="list-style-type: none"> • +: pin 2 • -: pin 5
11	Remove the motor by unscrewing its four attachment screws and plain washers.	
12	Fit the two <i>guide pins</i> in two of the <i>motor attachment holes</i> .	Art. no. is specified in Required equipment on page 299 . Shown in the figure Location of motor on page 299 .
13	If required, press the motor out of position by fitting the <i>removal tool, motor</i> to the remaining <i>motor attachment holes</i> .	Art. no. is specified in Required equipment on page 299 . Shown in the figure Location of motor on page 299 . Always use the removal tools in pairs!
14	Remove the removal tools and fit the <i>lifting tool, motor axis 2, 3, 4</i> to the motor.	Art. no. is specified in Required equipment on page 299 .
15	 CAUTION The motor weighs 32 kg! All lifting equipment used must be sized accordingly!	
16	Lift the motor to get the pinion away from the gear.	Make sure the motor pinion does not get damaged!
17	Remove the motor by gently lifting it straight out and place it on a secure surface. Disconnect the brake release voltage.	

Refitting, motor

The procedure below details how to refit the motor axis 2.

	Action	Note
1	 DANGER Turn off all: <ul style="list-style-type: none"> • electric power supply to the robot • hydraulic pressure supply to the robot • air pressure supply to the robot Before entering the robot working area.	
2	Make sure the <i>o-ring</i> on the circumference of the motor is seated properly. Lightly lubricate the o-ring with <i>grease</i> .	Art. no. is specified in Required equipment on page 299 .

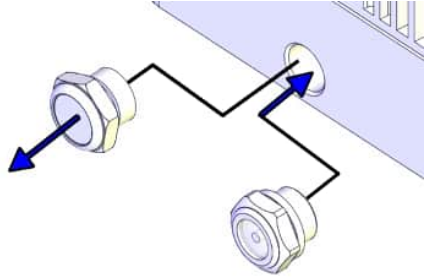
Continues on next page



	Action	Note
3	<p>Foundry Plus: If the motor is a new spare part, the evacuation hole protection filter must be replaced with a transparent plug/sight glass (enclosed with the spare part delivery). Remove the protection filter and install the transparent plug/sight glass.</p> <div style="display: flex; justify-content: space-around;"> <div data-bbox="507 510 740 801">  <p>xx1800000101 Protection filter (Standard).</p> </div> <div data-bbox="740 510 995 801">  <p>xx1800000102 Transparent plug (Foundry Plus).</p> </div> </div>	<p>Tightening torque, transparent plug: 20 Nm \pm10%. Tightening torque, protection filter: 10 Nm \pm10%.</p>  <p>xx1600000576</p>
4	<p>In order to release the brake, remove the cover on top of the motor and connect the 24 VDC power supply.</p>	<p>Connect to connector R2.MP2</p> <ul style="list-style-type: none"> • +: pin 2 • -: pin 5
5	<p>Fit the <i>lifting tool</i>, motor axis 2, 3, 4 to the motor.</p>	<p>Art. no. is specified in Required equipment on page 299.</p>
6	<p>Fit the two <i>guide pins</i> in the two lower <i>motor attachment holes</i>.</p>	<p>Art. no. is specified in Required equipment on page 299. Shown in the figure Location of motor on page 299.</p>
7	<p> CAUTION The motor weighs 32 kg! All lifting equipment used must be sized accordingly!</p>	
8	<p>Lift the motor and guide it onto the guide pins, as close to the correct position as possible without pushing the motor pinion into the gear. Make sure that the motor is turned the right direction, that is the cables facing downwards.</p>	
9	<p>Remove the lifting tool and allow the motor to rest on the guide pins.</p>	

Continues on next page

4 Repair

4.6.2 Replacement of motor axis 2

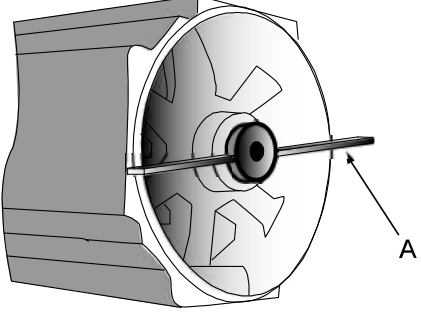
Continued

	Action	Note
10	Use the <i>rotation tool</i> in order to rotate the motor pinion when mating it to the gear (see the figure to the right). Fit the motor, making sure the motor pinion is properly mated to the gear of gearbox axis 2 and that it does not get damaged.	<p>Art. no. is specified in Required equipment on page 299.</p>  <p>xx0200000165</p> <p>The rotation tool is used beneath the motor cover, directly on the motor shaft as shown in the figure above.</p> <ul style="list-style-type: none"> A: Rotation tool
11	Remove the guide pins.	
12	Secure the motor with four attachment screws and plain washers.	M10 x 40, tightening torque: 50 Nm. Reused screws may be used, providing they are lubricated as detailed in section Screw joints on page 402 before fitting.
13	Disconnect the brake release voltage.	
14	Reconnect all connectors beneath the motor cover.	Connect in accordance with markings on connectors.
15	Refit the <i>cable gland cover</i> at the cable exit with its two attachment screws.	Shown in the figure Location of motor on page 299 .
16	Refit the cover on top of the motor with its four attachment screws.	Make sure the cover is tightly sealed!
17	Remove the lock screw from the <i>hole for lock screw</i> .	Shown in the figure Location of motor on page 299 .
18	Perform a leak down test.	Detailed in Performing a leak-down test on page 184 .
19	Refill the gearbox with oil.	Detailed in the section Changing oil, axis-2 gearbox on page 158 .
20	Recalibrate the robot.	<p>Axis Calibration is described in Calibrating with Axis Calibration method on page 372.</p> <p>General calibration information is included in section Calibration on page 359.</p>
21	 <p>DANGER</p> <p>Make sure all safety requirements are met when performing the first test run. See Test run after installation, maintenance, or repair on page 108.</p>	

4.6.3 Replacement of motor, axis 3

Location of motor

The motor axis 3 is located on the left hand side of the robot as shown in the figure below.

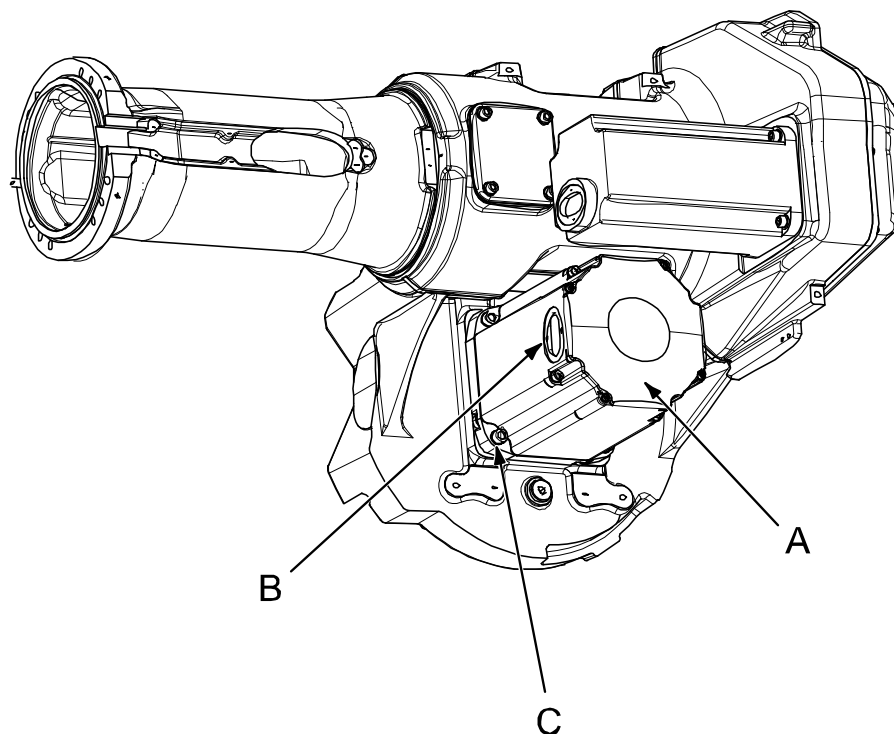

xx020000186

A	Motor axis 3
B	Cable gland cover, motor axis 3
C	Motor attachment holes (4 pcs)

Required equipment

Equipment, etc.	Spare part no.	Art. no.	Note
Motor including pinion	See Spare part lists on page 397 .		Includes <ul style="list-style-type: none"> • motor • pinion • o-ring 21522012-430
O-ring	21522012-430		Must be replaced when reassembling motor!
Mechanical stop axis 3		3HAC12708-1	May be used to fix axis 3. Use attachment screws 3HAB 3409-86 (M16 x 60).
Grease		3HAC042536-001	For lubricating the o-ring.
Removal tool, motor M12x		3HAC14631-1	Always use the removal tools in pairs!

Continues on next page

4 Repair

4.6.3 Replacement of motor, axis 3

Continued

Equipment, etc.	Spare part no.	Art. no.	Note
Lifting tool, motor ax 2, 3, 4		3HAC15534-1	
Bolts M16x60 (for mechanical stop axis 3)		3HAB3409-86	
Washers (for mechanical stop axis 3)		3HAA1001-186	
Guide pins M10 x 100		3HAC15521-1	For guiding the motor.
Guide pins M10 x 150		3HAC15521-2	For guiding the motor.
Rotation tool		3HAC17105-1	Used to rotate the motor pinion when mating it to the gear when brakes are released with 24 VDC power supply.
Power supply		-	24 VDC, max. 1.5 A For releasing the brakes.
Standard toolkit		-	Content is defined in section Standard tools on page 406 .
Calibration tool box, Axis Calibration		3HAC055412-001	Delivered as a set of calibration tools. Required if Axis Calibration is the valid calibration method for the robot.
Other tools and procedures may be required. See references to these procedures in the step-by-step instructions below.			These procedures include references to the tools required.
Circuit diagram			See chapter Circuit diagram on page 411 .

Deciding calibration routine

Decide which calibration routine to be used, based on the information in the table. Depending on which routine is chosen, action might be required prior to beginning the repair work of the robot, see the table.



	Action	Note
1	Decide which calibration routine to use for calibrating the robot. <ul style="list-style-type: none"> Reference calibration. External cable packages (DressPack) and tools can stay fitted on the robot. Fine calibration. All external cable packages (DressPack) and tools must be removed from the robot. 	

Continues on next page

Action	Note
<p>If the robot is to be calibrated with reference calibration: Find previous reference values for the axis or create new reference values. These values are to be used after the repair procedure is completed, for calibration of the robot. If no previous reference values exist, and no new reference values can be created, then reference calibration is not possible.</p>	<p>Follow the instructions given in the reference calibration routine on the FlexPendant to create reference values. Creating new values requires possibility to move the robot. Read more about reference calibration for Axis Calibration in Reference calibration routine on page 373.</p>
<p>If the robot is to be calibrated with fine calibration: Remove all external cable packages (DressPack) and tools from the robot.</p>	

Removal, motor

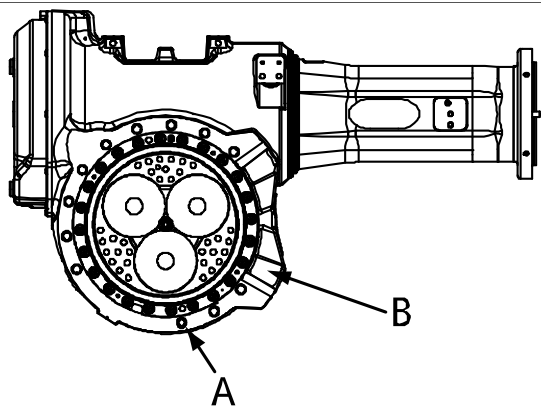
The procedure below details how to remove motor, axis 3.

Action	Note
<p>1 Decide which calibration routine to use, and take actions accordingly prior to beginning the repair procedure.</p>	
<p>2 Unload the upper arm of the robot by either:</p> <ul style="list-style-type: none"> • Use a fork lift to rest the upper arm onto. • Use lifting slings and an overhead crane to rest the upper arm. • Use a mechanical stop to rest the upper arm. Fit the mechanical stop in the attachment hole (A) with tightening torque: 115 Nm. 	 <p>xx0300000051</p> <p>Fit the mechanical stop to the third and final attachment hole (A), below the fixed stop (B) in the upper arm. See the figure above!</p>
<p>3  DANGER</p> <p>Turn off all:</p> <ul style="list-style-type: none"> • electric power supply to the robot • hydraulic pressure supply to the robot • air pressure supply to the robot <p>Before entering the robot working area.</p>	
<p>4 Drain the oil from gearbox axis 3.</p>	<p>Detailed in section Changing oil, axis-3 gearbox on page 161.</p>

Continues on next page

4 Repair

4.6.3 Replacement of motor, axis 3

Continued





	Action	Note
5	Remove any equipment hindering access to motor axis 3.	
6	Remove the cover on top of the motor by unscrewing its four attachment screws.	
7	Remove the <i>cable gland cover</i> at the cable exit by unscrewing its two securing screws.	Shown in the figure Location of motor on page 305 . Make sure the gasket is not damaged!
8	Disconnect all connectors beneath the motor cover.	
9	Unscrew the motors four <i>attachment screws and plain washers</i> .	Shown in the figure Location of motor on page 305 .
10	Fit the two <i>guide pins</i> in two of the motor attachment screw holes.	Art. no. is specified in Required equipment on page 305 .
11	Press the motor out of position by fitting <i>removal tool, motor</i> to the remaining motor attachment screw holes.	Art. no. is specified in Required equipment on page 305 . Always use the removal tools in pairs!
12	Apply the <i>lifting tool, motor axis 2 ,3, 4</i> to the motor.	Art. no. is specified in Required equipment on page 305 .
13	 CAUTION The motor weighs 27 kg! All lifting equipment used must be sized accordingly!	
14	Lift the motor to get the pinion away from the gear.	
15	Remove the motor by gently lifting it straight out and disconnect the brake release voltage.	Make sure the motor pinion is not damaged!

Refitting, motor

The procedure below details how to refit motor, axis 3.

	Action	Note
1	 DANGER Turn off all: <ul style="list-style-type: none"> • electric power supply to the robot • hydraulic pressure supply to the robot • air pressure supply to the robot Before entering the robot working area.	
2	Make sure the <i>o-ring</i> on the circumference of the motor is seated properly. Lightly lubricate it with <i>grease</i> .	Art no. is specified in Required equipment on page 305 .

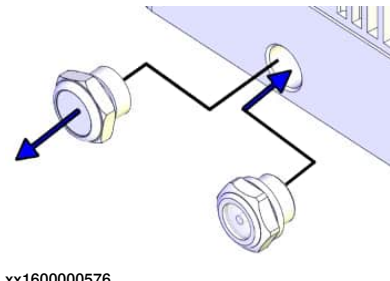
Continues on next page



	Action	Note
3	<p>Foundry Plus: If the motor is a new spare part, the evacuation hole protection filter must be replaced with a transparent plug/sight glass (enclosed with the spare part delivery). Remove the protection filter and install the transparent plug/sight glass.</p> <div style="display: flex; justify-content: space-around;"> <div data-bbox="502 488 754 795">  <p>xx180000101 Protection filter (Standard).</p> </div> <div data-bbox="754 488 1032 795">  <p>xx180000102 Transparent plug (Foundry Plus).</p> </div> </div>	<p>Tightening torque, transparent plug: 20 Nm ±10%. Tightening torque, protection filter: 10 Nm ±10%.</p>  <p>xx1600000576</p>
4	Fit the <i>lifting tool</i> , motor axis 2, 3, 4 to the motor.	Art no. is specified in Required equipment on page 305 .
5	Fit the two <i>guide pins</i> in the two lower motor attachment holes.	Art no. is specified in Required equipment on page 305 . Shown in the figure Location of motor on page 305
6	<p> CAUTION</p> <p>The motor weighs 27 kg! All lifting equipment used must be sized accordingly!</p>	
7	Lift the motor and guide it onto the guide pins, as close to the correct position as possible without pushing the motor pinion into the gear.	
8	Remove the lifting tool and allow the motor to stay on the guide pins.	
9	In order to release the brake, connect the 24 VDC power supply.	Connect to connector R2.MP3 <ul style="list-style-type: none"> • +: pin 2 • -: pin 5

Continues on next page

4 Repair

4.6.3 Replacement of motor, axis 3

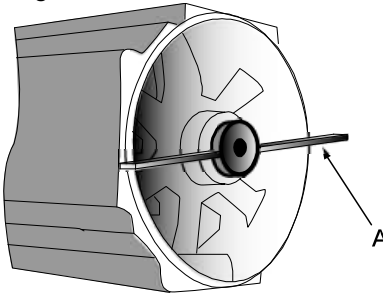
Continued

	Action	Note
10	<p>Use the <i>rotation tool</i> in order to rotate the motor pinion when mating it to the gear!</p> <p>Fit the motor, making sure the motor pinion is properly mated to the gear of gearbox, axis 3.</p>	<p>Art no. is specified in Required equipment on page 305.</p> <p>Make sure the motor pinion does not get damaged!</p> <p>Make sure the motor is turned the right direction, that is the cables facing forwards.</p>  <p>xx0200000165</p> <p>The rotation tool is used beneath the motor cover, directly on the motor shaft as shown in figure above.</p> <ul style="list-style-type: none"> A: Rotation tool.
11	Remove the guide pins.	
12	Secure the motor with four attachment screws and plain washers.	4 pcs: M10 x 40, tightening torque: 50 Nm.
13	Disconnect the brake release voltage.	
14	Reconnect all connectors beneath the motor cover.	Connect in accordance with markings on connectors.
15	Refit the <i>cable gland cover</i> at the cable exit with its two attachment screws.	<p>Make sure the cover is tightly sealed!</p> <p>Shown in the figure Location of motor on page 305.</p>
16	Refit the cover on top of the motor with its four attachment screws.	Make sure the cover is tightly sealed!
17	Remove the equipment used to unload the upper arm.	
18	Perform a leak-down test.	Detailed in the section Performing a leak-down test on page 184 .
19	Refill the gearbox with oil.	Detailed in the section Changing oil, axis-3 gearbox on page 161 .
20	Recalibrate the robot!	<p>Axis Calibration is described in Calibrating with Axis Calibration method on page 372.</p> <p>General calibration information is included in section Calibration on page 359.</p>
21	 <p>DANGER</p> <p>Make sure all safety requirements are met when performing the first test run. See Test run after installation, maintenance, or repair on page 108.</p>	

4.6.4 Replacement of motor, axis 4

Location of motor

The motor axis 4 is located on the left-hand side of the upper arm as shown in the figure below.

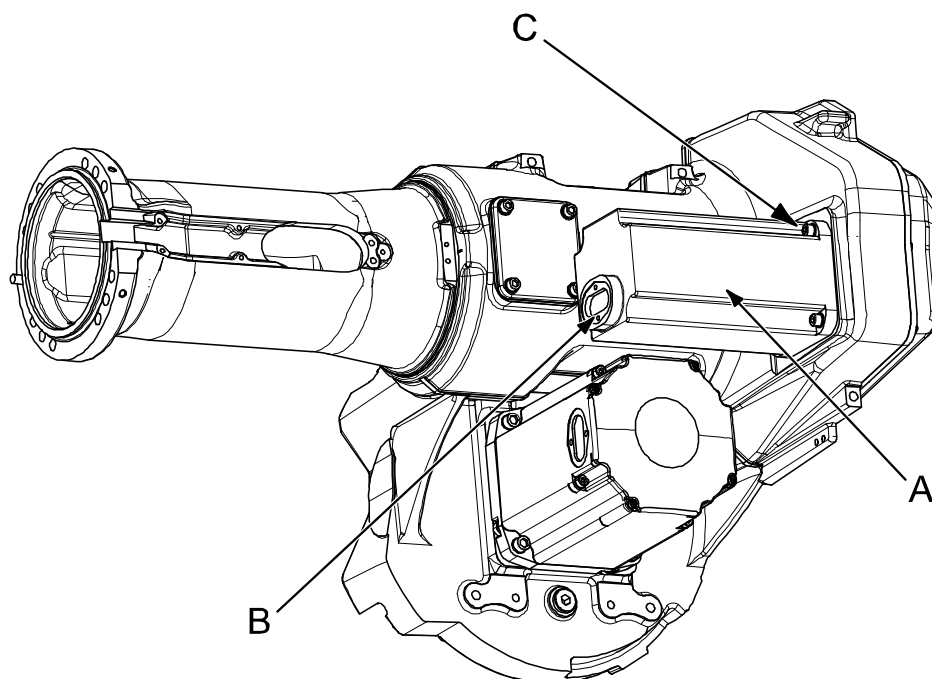

xx0200000202

A	Motor, axis 4
B	Cable gland cover, motor axis 4
C	Motor attachment holes (4 pcs)

Required equipment

Equipment, etc.	Art. no.	Note
Motor including pinion	See spare part number in Spare part lists on page 397 .	Includes: <ul style="list-style-type: none"> • motor • pinion • o-ring 21522012-430
O-ring	21522012-430	Must be replaced when reassembling motor!
Lifting tool, motor ax 1, 4, 5	3HAC14459-1	
Lifting tool, motor ax 2, 3, 4	3HAC15534-1	
Grease	3HAC042536-001	Used to lubricate the o-ring.
Loctite 574, Flange sealant	12340011-116	Option Foundry Plus
Removal tool. motor M10x	3HAC14972-1	Always use the removal tools in pairs!
Guide pins M8 x 100	3HAC15520-1	For guiding the motor.

Continues on next page

4 Repair

4.6.4 Replacement of motor, axis 4

Continued

Equipment, etc.	Art. no.	Note
Guide pins M8 x 150	3HAC15520-2	For guiding the motor.
Rotation tool	3HAC17105-1	Used to rotate the motor pinion when mating it to the gear when brakes are released with 24 VDC power supply.
Power supply	-	24 VDC, max. 1,5 A For releasing the brakes.
Standard toolkit	-	Content is defined in section Standard tools on page 406 .
Calibration tool box, Axis Calibration	3HAC055412-001	Delivered as a set of calibration tools. Required if Axis Calibration is the valid calibration method for the robot.
Other tools and procedures may be required. See references to these procedures in the step-by-step instructions below.		These procedures include references to the tools required.
Circuit diagram		See chapter Circuit diagram on page 411 .

Deciding calibration routine

Decide which calibration routine to be used, based on the information in the table. Depending on which routine is chosen, action might be required prior to beginning the repair work of the robot, see the table.

	Action	Note
1	<p>Decide which calibration routine to use for calibrating the robot.</p> <ul style="list-style-type: none"> Reference calibration. External cable packages (DressPack) and tools can stay fitted on the robot. Fine calibration. All external cable packages (DressPack) and tools must be removed from the robot. 	
	<p>If the robot is to be calibrated with reference calibration:</p> <p>Find previous reference values for the axis or create new reference values. These values are to be used after the repair procedure is completed, for calibration of the robot.</p> <p>If no previous reference values exist, and no new reference values can be created, then reference calibration is not possible.</p>	<p>Follow the instructions given in the reference calibration routine on the FlexPendant to create reference values.</p> <p>Creating new values requires possibility to move the robot.</p> <p>Read more about reference calibration for Axis Calibration in Reference calibration routine on page 373.</p>
	<p>If the robot is to be calibrated with fine calibration:</p> <p>Remove all external cable packages (DressPack) and tools from the robot.</p>	

Continues on next page

Removal, motor axis 4

The procedure below details how to remove the motor, axis 4.

	Action	Note
1	Decide which calibration routine to use, and take actions accordingly prior to beginning the repair procedure.	
2	Move the robot to a position where the upper arm is pointed straight up. This position enables the motor to be replaced without draining the gear oil, which in turn saves time. Any other position of the upper arm requires a draining of oil from the gearbox for axis 4.	Draining of oil is described in section Draining, oil on page 164 .
3	 DANGER Turn off all: <ul style="list-style-type: none"> • electric power supply to the robot • hydraulic pressure supply to the robot • air pressure supply to the robot Before entering the robot working area.	
4	Remove the <i>cable gland cover</i> at the cable exit of the motor by unscrewing its two attachment screws.	Shown in the figure Location of motor on page 311 . Make sure the gasket is not damaged!
5	Remove the cover on top of the motor by unscrewing its four attachment screws.	
6	Disconnect all connectors beneath the motor cover.	
7	In order to release the brake, connect the 24 VDC power supply.	Connect to connector R2.MP4 <ul style="list-style-type: none"> • +: pin 2 • -: pin 5
8	Unscrew the motors four <i>attachment screws and plain washers</i> .	Shown in the figure Location of motor on page 311 .
9	Fit the two <i>guide pins</i> in two of the motor attachment screw holes.	
10	If required, press the motor out of position by fitting <i>removal tool, motor</i> to the motor attachment screw holes.	Art. no. is specified in Required equipment on page 311 . Always use the removal tools in pairs!
11	Lift the motor to get the pinion away from the gear and disconnect the brake release voltage.	
12	Remove the motor by gently lifting it straight out.	Make sure the motor pinion is not damaged!

Continues on next page



4 Repair

4.6.4 Replacement of motor, axis 4



Continued

Refitting, motor axis 4

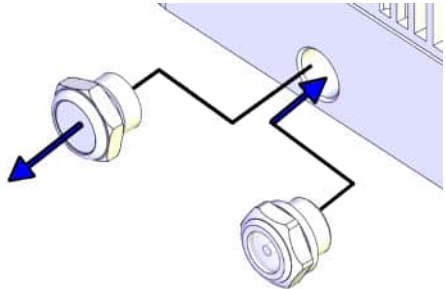
The procedure below details how to refit motor, axis 4.

	Action	Note
1	 DANGER Turn off all: <ul style="list-style-type: none"> • electric power supply to the robot • hydraulic pressure supply to the robot • air pressure supply to the robot Before entering the robot working area.	
2	Make sure the <i>o-ring</i> on the circumference of the motor is seated properly. Lightly lubricate the <i>o-ring</i> with <i>grease</i> .	Art. no. is specified in Required equipment on page 311 .
3	Foundry Plus: If the motor is a new spare part, the evacuation hole protection filter must be replaced with a transparent plug/sight glass (enclosed with the spare part delivery). Remove the protection filter and install the transparent plug/sight glass. <div style="display: flex; justify-content: space-around; margin-top: 10px;"> <div style="text-align: center;">  <p>xx1800000101</p> <p>Protection filter (Standard).</p> </div> <div style="text-align: center;">  <p>xx1800000102</p> <p>Transparent plug (Foundry Plus).</p> </div> </div>	Tightening torque, transparent plug: 20 Nm \pm 10%. Tightening torque, protection filter: 10 Nm \pm 10%. <div style="text-align: right; margin-top: 10px;">  <p>xx1600000576</p> </div>
4	In order to release the brakes, connect the 24 VDC power supply.	Connect to connector R2.MP4: <ul style="list-style-type: none"> • +: pin 2 • -: pin 5
5	Fit the two <i>guide pins</i> in two of the <i>motor attachment holes</i> .	Art. no. is specified in Required equipment on page 311 . Shown in the figure Location of motor on page 311 .
6	Fit the motor with guidance of the pins, making sure the motor pinion is properly mated to the gear of gearbox 4.	Make sure the motor pinion does not get damaged!

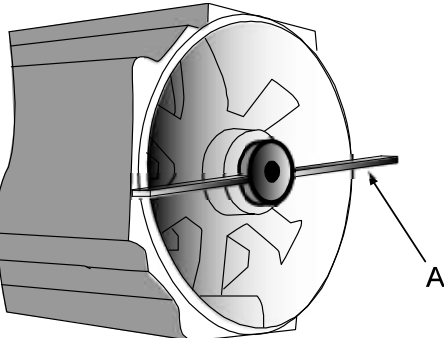
Continues on next page

	Action	Note
7	<p>Use the <i>rotation tool</i> in order to rotate the motor pinion when mating it to the gear! Fit the motor, making sure the motor pinion is properly mated to the gear, axis 4.</p>	<p>Art. no. is specified in Required equipment on page 311. Make sure the motor pinion does not get damaged! Make sure the motor is turned the right direction, that is the cables facing forwards.</p>  <p>xx020000165</p> <p>The rotation tool is used beneath the motor cover, directly on the motor shaft as shown in figure above.</p> <ul style="list-style-type: none"> A: Rotation tool.
8	Remove the guide pins.	
9	Secure the motor with four attachment screws and plain washers.	4 pcs: M8 x 25, tightening torque: 24 Nm.
10	Disconnect the brake release voltage.	
11	Reconnect all connectors beneath the motor cover.	
12	Refit the cover on top of the motor with its four attachment screws.	Make sure the cover is tightly sealed!
13	Refit the <i>cable gland cover</i> at the cable exit with its two attachment screws.	Shown in the figure Location of motor on page 311 .
14	Perform a leak-down test if the gearbox has been drained.	Detailed in the section Performing a leak-down test on page 184 .
15	Refill the gearbox with oil if drained.	Detailed in the section Filling, oil on page 165 .
16	Recalibrate the robot!	<p>Axis Calibration is described in Calibrating with Axis Calibration method on page 372. General calibration information is included in section Calibration on page 359.</p>
17	 <p>DANGER</p> <p>Make sure all safety requirements are met when performing the first test run. See Test run after installation, maintenance, or repair on page 108.</p>	

4 Repair

4.6.5 Replacement of motor, axis 5

4.6.5 Replacement of motor, axis 5

Reused pinion

The pinion in the motor, axis 5, is matched with the bevel gear for axis 5. When the motor is replaced the pinion must therefore be removed from the dismantled motor and fitted onto the new motor shaft as detailed in this section.

Location of motor

The motor axis 5 is located inside the upper arm tube, but attached to the wrist unit, as shown in the figure below.

A more detailed view of the component and its position may be found in [Spare part lists on page 397](#).

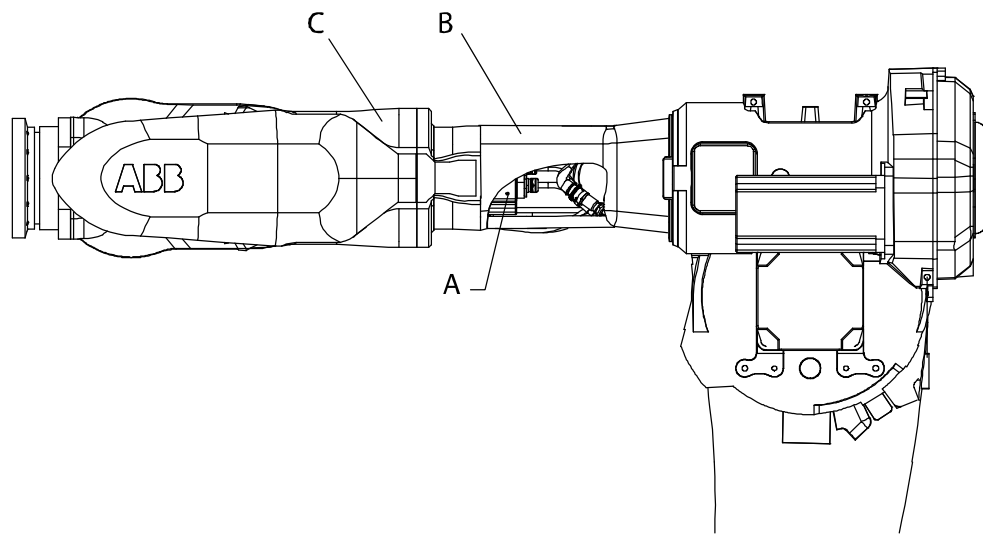

xx020000204

A	Motor, axis 5
B	Upper arm tube
C	Wrist unit

Required equipment

Equipment, etc.	Art. no.	Note
Motor	For spare part number, see Spare part lists on page 397 .	Does not include pinion. Use the pinion from the motor to be replaced. Includes o-ring 21522012-430.
Set of shim, motor	3HAC7941-28	Used to obtain the correct distance between motor flange and outer surface of motor pinion.
O-ring	21522012-430	Must be replaced when reassembling motor!
Grease	3HAC042536-001	For lubricating the o-ring.
Loctite 574, Flange sealant	12340011-116	Option Foundry Plus

Continues on next page

Equipment, etc.	Art. no.	Note
Isopropanol	11771012-208	For cleaning motor pinion and motor pinion hole.
Mineral oil	CS 320	For lubrication of pinion shaft and pinion hole.
Removal tool, motor M10x	3HAC14972-1	Always use the removal tools in pairs!
Oil injector / max 500 MPa	3HAC021590-001	For pressing out the pinion, motor 5.
Press fixture (for pinion)	-	For pressing the pinion on to the new motor.
Measuring tool	6896134-GN	
Guide pins M8 x 100	3HAC15520-1	For guiding the motor.
Guide pins M8 x 150	3HAC15520-2	For guiding the motor.
Power supply	-	24 VDC, 1.5 A For releasing the brakes.
Standard toolkit	-	Content is defined in section Standard tools on page 406 .
Other tools and procedures may be required. See references to these procedures in the step-by-step instructions below.		These procedures include references to the tools required.
Circuit diagram	-	See chapter Circuit diagram on page 411 .

Deciding calibration routine

Decide which calibration routine to be used, based on the information in the table. Depending on which routine is chosen, action might be required prior to beginning the repair work of the robot, see the table.

	Action	Note
1	<p>Decide which calibration routine to use for calibrating the robot.</p> <ul style="list-style-type: none"> Reference calibration. External cable packages (DressPack) and tools can stay fitted on the robot. Fine calibration. All external cable packages (DressPack) and tools must be removed from the robot. 	
	<p>If the robot is to be calibrated with reference calibration:</p> <p>Find previous reference values for the axis or create new reference values. These values are to be used after the repair procedure is completed, for calibration of the robot.</p> <p>If no previous reference values exist, and no new reference values can be created, then reference calibration is not possible.</p>	<p>Follow the instructions given in the reference calibration routine on the FlexPendant to create reference values.</p> <p>Creating new values requires possibility to move the robot.</p> <p>Read more about reference calibration for Axis Calibration in Reference calibration routine on page 373.</p>

Continues on next page

4 Repair

4.6.5 Replacement of motor, axis 5

Continued

Action	Note
<p>If the robot is to be calibrated with fine calibration: Remove all external cable packages (DressPack) and tools from the robot.</p>	

Removal, motor, axis 5

The procedure below details how to remove motor, axis 5.

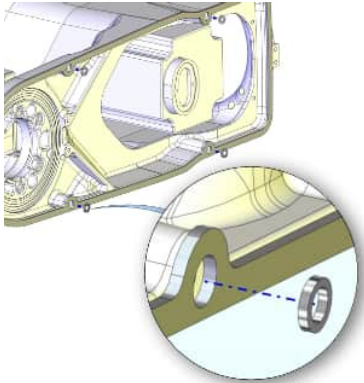
Action	Note
1	Decide which calibration routine to use, and take actions accordingly prior to beginning the repair procedure.
2	<p> DANGER</p> <p>Turn off all:</p> <ul style="list-style-type: none"> • electric power supply to the robot • hydraulic pressure supply to the robot • air pressure supply to the robot <p>Before entering the robot working area.</p>
3	Drain the oil from gearbox axis 5. Detailed in the section Changing oil, axis-5 gearbox on page 167 .
4	<p>Remove the wrist unit.</p> <p>Detailed in the section Removal, wrist unit on page 237.</p>  <p>xx1400002580</p>
5	Place the wrist unit safely on a workbench, in a fixture or similar.
6	Remove the cover on top of the motor by unscrewing its four attachment screws.
7	Remove the cable gland cover at the cable exit by unscrewing its two attachment screws.
8	Disconnect all connectors beneath the motor cover and remove the separate cable of the axis-5 motor.

Continues on next page

	Action	Note
9	In order to release the brake, connect the 24 VDC power supply.	Connect to either: - connector R4.MP5 (in the motor): • + : pin 2 • -: pin 5 - connector R3.MP5 (on the separate cable, if not removed): • +: pin C • -: pin D
10	Remove the motor by unscrewing its four attachment screws and plain washers.	
11	Fit the two <i>guide pins</i> in two of the motor attachment screw holes.	Art. no. is specified in Required equipment on page 316 .
12	If required, press the motor out of position by fitting <i>removal tool, motor, M10</i> to the motor attachment screw holes.	Art. no. is specified in Required equipment on page 316 . Always use the removal tools in pairs and diagonally!
13	Lift the motor to get the pinion away from the gear and disconnect the brake release voltage.	Make sure the motor pinion is not damaged!
14	Remove the motor by gently lifting it straight out.	Keep track of the shims between the motor flange and the wrist housing.
15	Measure the distance between the motor flange, included eventual shims, and the outer surface of the pinion, with <i>measuring tool</i> .	Art. no. is specified in Required equipment on page 316 . Make a note of the distance.
16	Press out the pinion from the dismantled motor, with the equipment included in the <i>oil injector kit</i> .  Note If the pinion is damaged the complete wrist unit must be replaced!	Replacing the complete wrist unit is detailed in section Replacement of complete wrist unit on page 235 . Art. no. is specified in Required equipment on page 316 .

Refitting, motor, axis 5

The procedure below details how to refit motor, axis 5.

	Action	Note
1	 DANGER Turn off all: • electric power supply to the robot • hydraulic pressure supply to the robot • air pressure supply to the robot Before entering the robot working area.	
2	Make sure the <i>o-ring</i> on the circumference of the motor is seated properly. Lightly lubricate the <i>o-ring</i> with <i>grease</i> .	Art. no. is specified in Required equipment on page 316 .

Continues on next page



4 Repair

4.6.5 Replacement of motor, axis 5

Continued

	Action	Note
3	<p>Clean the pinion and the pinion hole in the motor, with <i>isopropanol</i>.</p> <p> Note</p> <p>If the pinion is damaged the complete wrist unit must be replaced!</p>	<p>Art. no. is specified in Required equipment on page 316.</p> <p>Replacing the complete wrist unit is detailed in section Replacement of complete wrist unit on page 235.</p>
4	<p>Apply a thin film of <i>mineral oil</i> to the pinion shaft and the pinion hole in order to make the pinion run smoothly and to achieve an even friction torque when assembling the pinion.</p>	<p>Art. no. is specified in Required equipment on page 316.</p>
5	<p>Place the motor and pinion in a <i>press fixture</i>.</p>	
6	<p>Press the pinion onto the new motor and check the pressing force.</p> <p>For an axis diameter of 15.5 mm, use min. pressing force: 18.5 kN and max. pressing force: 39.5 kN.</p>	<p>If the pressing force is outside the given range or if the pinion "jumps" in bit by bit, it must be dismantled, checked, cleaned and oiled before it is assembled once again!</p>
7	<p>Measure the distance between the motor flange and the outer surface of the pinion with the <i>measuring tool</i>.</p> <p>Modify the distance with <i>shims</i> in order to obtain the same distance as measured when dismantling the old motor (+ 0-0,05 mm).</p>	<p>Art. no. is specified in Required equipment on page 316.</p>
8	<p>In order to release the brake, connect the 24 VDC power supply.</p>	<p>Connect to either:</p> <ul style="list-style-type: none"> - connector R4.MP5 (in the motor): <ul style="list-style-type: none"> • +: pin 2 • -: pin 5 - connector R3.MP5 (on the separate cable, if not removed): <ul style="list-style-type: none"> • +: pin C • -: pin D
9	<p>Fit the two <i>guide pins</i> in two of the motor attachment holes.</p>	<p>Art. no. is specified in Required equipment on page 316.</p>
10	<p>Fit the motor, with guidance from the pins, making sure the motor pinion is properly mated to the gear of axis 5.</p>	<p>Make sure the motor pinion does not get damaged!</p>
11	<p>Secure the motor with four attachment screws and plain washers.</p>	<p>4 pcs: M8 x 25; tightening torque: 24 Nm.</p>
12	<p>Disconnect the brake release voltage.</p>	
13	<p>Refit the separate cable of the axis-5 motor and reconnect all connectors beneath the motor cover.</p>	
14	<p>Refit the cable gland cover at the cable exit with its two attachment screws.</p>	
15	<p>Refit the cover on top of the motor with its four attachment screws.</p>	<p>Make sure the cover is tightly sealed!</p>
16	<p>Perform a leak-down test.</p>	<p>Detailed in the section Performing a leak-down test on page 184.</p>
17	<p>Refit the wrist unit.</p>	<p>Detailed in the section Refitting, wrist unit on page 238.</p>

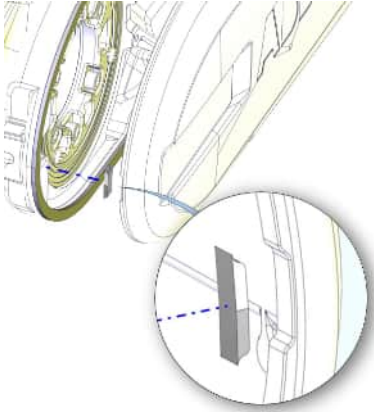
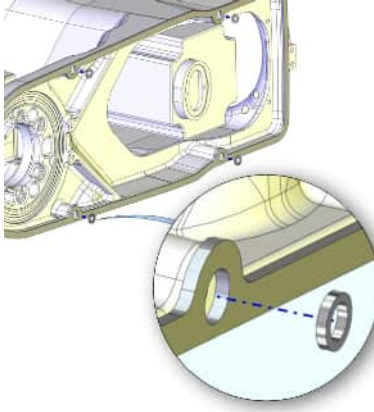
Continues on next page

	Action	Note
18	<p>Foundry Plus</p> <p>Make sure that the gasket is undamaged. Also the small gasket fitted in the cover recess. Replace if damaged.</p>	 <p>xx1400002579</p>
19	<p>Foundry Plus</p> <p>Make sure the washers are fitted in the gasket holes. Refit the <i>cover, wrist unit Foundry Plus</i>.</p>	 <p>xx1400002580</p>
20	Refill the gear with oil.	Detailed in the section Changing oil, axis-5 gearbox on page 167 .
21	Re-calibrate the robot.	<p>Axis Calibration is described in Calibrating with Axis Calibration method on page 372.</p> <p>General calibration information is included in section Calibration on page 359.</p>
22	<p> DANGER</p> <p>Make sure all safety requirements are met when performing the first test run. See Test run after installation, maintenance, or repair on page 108.</p>	

4 Repair

4.6.6 Replacement of motor, axis 6

4.6.6 Replacement of motor, axis 6

Location of motor

The motor axis 6 is located in the center of the wrist unit as shown in the figure below.

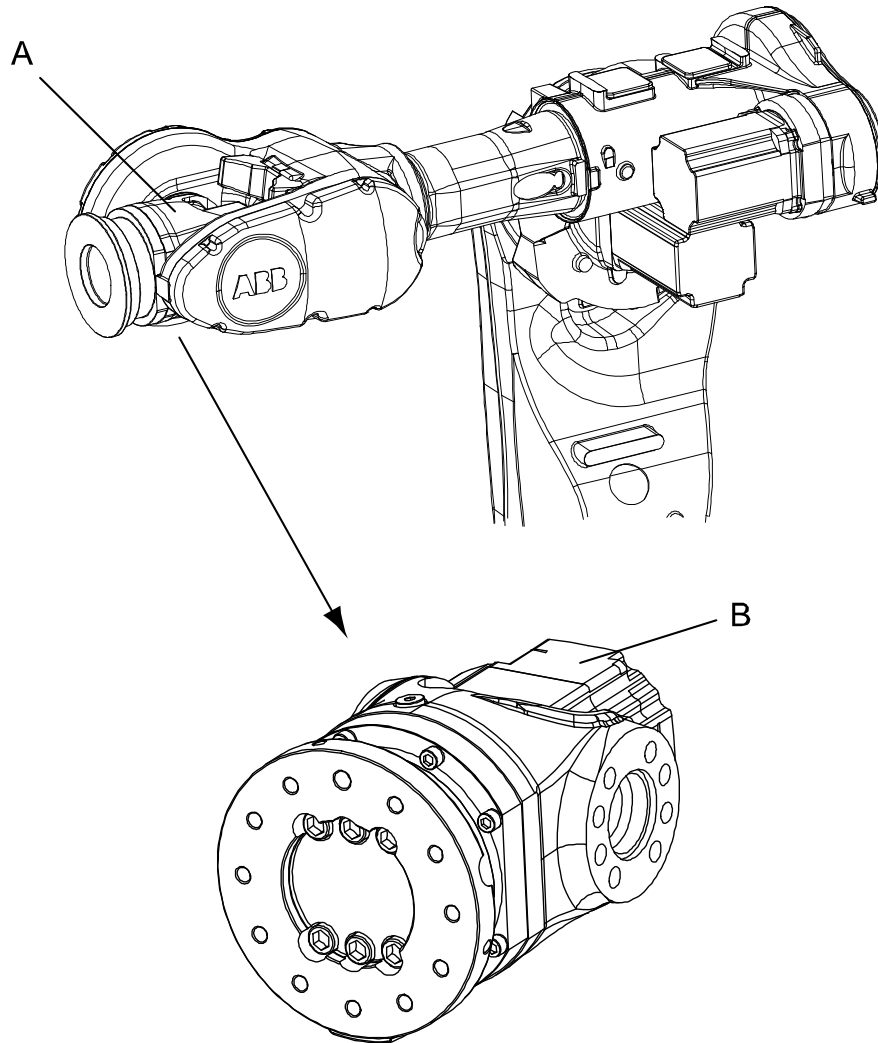

xx0200000222

A	Wrist unit
B	Motor, axis 6

Required equipment

Equipment, etc.	Spare part no.	Art. no.	Note
Motor including pinion	See spare part number in Spare part lists on page 397 .		Includes: <ul style="list-style-type: none">• motor• pinion• o-ring 21522012-430
O-ring	21522012-430		Must be replaced when reassembling motor!

Continues on next page

Equipment, etc.	Spare part no.	Art. no.	Note
Gasket	3HAC048560-001 i 3HAC063071-001 ii		Must be replaced when replacing motor
Gasket, cover	3HAC033489-001		Must be replaced when opening cover.
Removal tool, motor M10x		3HAC14972-1	Always use the removal tools in pairs!
Guide pins M8 x 100		3HAC15520-1	For guiding the motor.
Guide pins M8 x 150		3HAC15520-2	For guiding the motor.
Power supply		-	24 VDC, 1.5 A For releasing the brakes.
Grease		3HAC042536-001	For lubricating the o-ring.
Loctite 574, Flange sealant		12340011-116	Option Foundry Plus
Standard toolkit		-	Content is defined in section Standard tools on page 406 .
Calibration tool box, Axis Calibration		3HAC055412-001	Delivered as a set of calibration tools. Required if Axis Calibration is the valid calibration method for the robot.
Other tools and procedures may be required. See references to these procedures in the step-by-step instructions below.			These procedures include references to the tools required.
Circuit diagram		-	See chapter Circuit diagram on page 411 .

i Only fits type A motor.
See [Type A vs type B motors on page 395](#).

ii Only fits type B motor.
See [Type A vs type B motors on page 395](#).

Deciding calibration routine

Decide which calibration routine to be used, based on the information in the table. Depending on which routine is chosen, action might be required prior to beginning the repair work of the robot, see the table.

	Action	Note
1	Decide which calibration routine to use for calibrating the robot. <ul style="list-style-type: none"> Reference calibration. External cable packages (DressPack) and tools can stay fitted on the robot. Fine calibration. All external cable packages (DressPack) and tools must be removed from the robot. 	

Continues on next page

4 Repair

4.6.6 Replacement of motor, axis 6

Continued

Action	Note
<p>If the robot is to be calibrated with reference calibration: Find previous reference values for the axis or create new reference values. These values are to be used after the repair procedure is completed, for calibration of the robot. If no previous reference values exist, and no new reference values can be created, then reference calibration is not possible.</p>	<p>Follow the instructions given in the reference calibration routine on the FlexPendant to create reference values. Creating new values requires possibility to move the robot. Read more about reference calibration for Axis Calibration in Reference calibration routine on page 373.</p>
<p>If the robot is to be calibrated with fine calibration: Remove all external cable packages (DressPack) and tools from the robot.</p>	

Removal, motor

The procedure below details how to remove the motor, axis 6.

	<p>Note</p> <p>Robots with protection type Foundry Plus or Foundry Prime require special repair routines to maintain the tightness level, in addition to the procedure below, described in Replacement of the motor axis 6 (Foundry Plus) on page 326.</p>
---	---

Action	Note
1	Decide which calibration routine to use, and take actions accordingly prior to beginning the repair procedure.
2	Move the robot to a position where the motor in axis 6 is pointed straight up. This position enables the motor to be replaced without draining the gear oil, which in turn saves time.
3	<div style="display: flex; align-items: center;">  <p>DANGER</p> </div> <p>Turn off all:</p> <ul style="list-style-type: none"> • electric power supply to the robot • hydraulic pressure supply to the robot • air pressure supply to the robot <p>Before entering the robot working area.</p>
4	Remove the rear motor cover by unscrewing the five attachment screws.
5	Disconnect all connectors beneath the cover.
6	<p>Connect the 24 VDC power supply to release the brakes.</p> <p>Connect to connector R3.MP6</p> <ul style="list-style-type: none"> • +: pin 2 • -: pin 5
7	Remove the motor by unscrewing its four attachment screws and plain washers.

Continues on next page

	Action	Note
8	If required, press the motor out of position by fitting <i>removal tool, motor</i> to the motor attachment screw holes.	Art. no. is specified in Required equipment on page 322 . Always use the removal tools in pairs!
9	Lift the motor carefully to get the pinion away from the gear and disconnect the brake release voltage.	Make sure the motor pinion is not damaged!
10	Remove the motor by gently lifting it straight out.	

Refitting, motor

The procedure below details how to refit motor, axis 6.

**Note**

Robots with protection type Foundry Plus or Foundry Prime require special repair routines to maintain the tightness level, in addition to the procedure below, described in [Replacement of the motor axis 6 \(Foundry Plus\) on page 326](#).

	Action	Note
1	Make sure the <i>o-ring</i> on the circumference of the motor is seated properly. Lightly lubricate the o-ring with <i>grease</i> .	Art. no. is specified in Required equipment on page 322 .
2	In order to release the brake, connect the 24 VDC power supply.	Connect to connector R3.MP6 <ul style="list-style-type: none"> • +: pin 2 • -: pin 5
3	Fit the two <i>guide pins</i> in two of the motor attachment holes.	Art. no. is specified in Required equipment on page 322 .
4	Fit the motor, with guidance from the pins, making sure the motor pinion is properly mated to the gear of gearbox, axis 6.	Make sure the pinion on the motor shaft is not damaged!
5	Remove the guide pins.	
6	Secure the motor with its four attachment screws and plain washers.	4 pcs: M8 x 25, tightening torque: 24 Nm.
7	Disconnect the brake release voltage.	
8	Reconnect all connectors beneath the motor cover.	
9	Refit the cover on top of the motor with its five attachment screws.	Make sure the cover is tightly sealed!
10	Re-calibrate the robot.	Axis Calibration is described in Calibrating with Axis Calibration method on page 372 . General calibration information is included in section Calibration on page 359 .
11	DANGER Make sure all safety requirements are met when performing the first test run. See Test run after installation, maintenance, or repair on page 108 .	

Continues on next page

4 Repair



4.6.6 Replacement of motor, axis 6

Continued

Replacement of the motor axis 6 (Foundry Plus)

Robots with protection type Foundry Plus require special repair routines to maintain the tightness level.

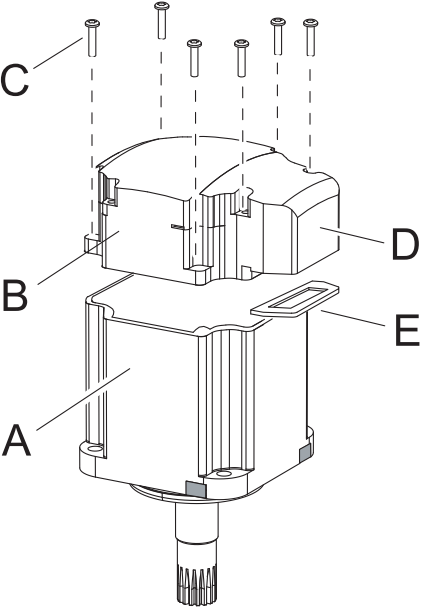
The repair must be done according to the previous repair procedure with the following additions.

	Action	Note
1	Move the robot to a position where the motor in axis 6 is pointed straight up. This position enables the motor to be replaced without draining the gear oil, which in turn saves time.	
2	 DANGER Turn off all: <ul style="list-style-type: none"> • electric power supply to the robot • hydraulic pressure supply to the robot • air pressure supply to the robot Before entering the robot working area.	
3	Remove the rear motor cover by unscrewing the five attachment screws.	 <p>xx1500002524</p> <ul style="list-style-type: none"> • A: Motor unit • B: Connection box • C: Attachment screw (5 pcs) • D: Rear motor cover • E: Gasket
4	Continue to remove the motor unit, according to step 6 and forwards in Removal, motor on page 324 .	
5	 Note Keep the old <i>rear motor cover</i> with the air nipple.	

Continues on next page

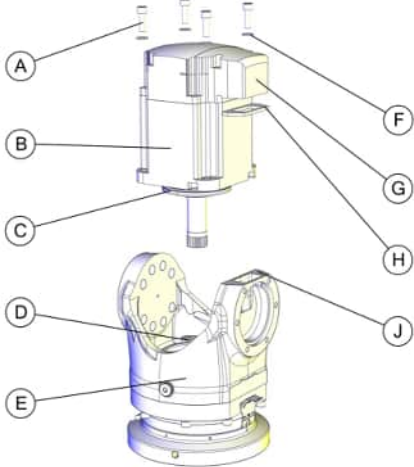
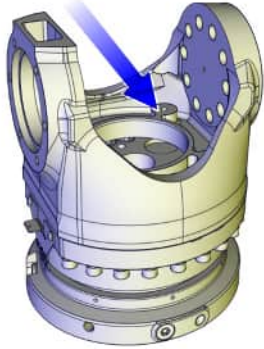
	Action	Note
6	Remove the protection strip on the <i>gasket</i> and mount it on the <i>motor</i> .	 <p>xx1500002425</p> <ul style="list-style-type: none"> • A: Attachment screw (4pcs) Mercasol 3106 • B: Motor unit • C: O-ring • D: Sikaflex in screw recesses • E: Tilt house • F: Washer • G: Rear motor cover • H: Sealing • J: Loctite 574
7	Apply Mercasol 3106 on the <i>motor end cover</i> .	
8	Apply Loctite 574 flange sealant on the contact surface.	 <p>xx1400000992</p>
9	Apply grease on the <i>o-ring</i> on the <i>motor</i> .	
10	Continue to refit the new motor according to section, Refitting, motor on page 325 .	

4 Repair

4.7.1 Replacing the axis 1 gearbox

4.7 Gearboxes

4.7.1 Replacing the axis 1 gearbox

Location of gearbox

The axis 1 gearbox is located between the frame and base as shown in the figure.

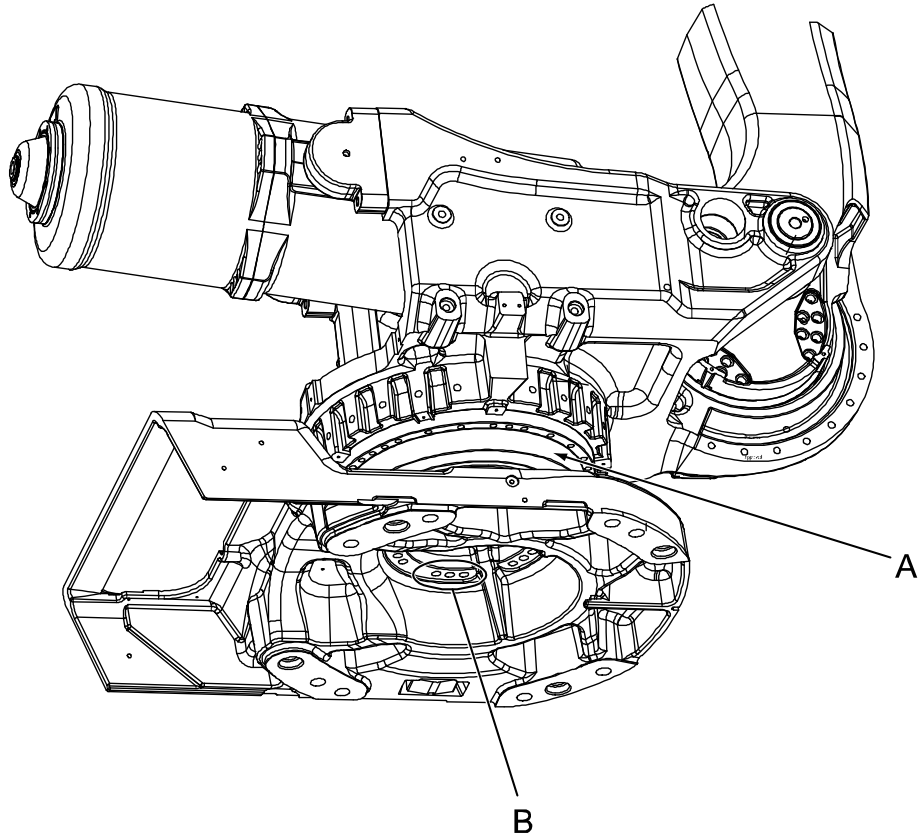

xx0300000538

A	Gearbox, axis 1
B	Attachment screws, gearbox axis 1 (18 pcs)

Required equipment

Equipment, etc.	Art. no.	Note
Gearbox	For spare part no. see: • Spare part lists on page 397.	Includes: • gearbox • all o-rings and sealing rings
O-ring	3HAB3772-54	Replace if damaged!
O-ring	3HAB3772-55	Replace if damaged!
Sealing ring	3HAC11581-4	Replace if damaged!
Grease	3HAC042536-001	Shell Gadus S2 For lubricating the o-ring.
Support, base and gear 1	3HAC15535-1	

Continues on next page

Equipment, etc.	Art. no.	Note
Lifting accessory, base	3HAC15560-1	
Lifting accessory (chain)	3HAC15556-1	
Guide pins		2 pcs, M16x150. Used for guiding the gearbox into place in the base. Always use guide pins in pairs!
Calibration tool box, Axis Calibration	3HAC055412-001	Delivered as a set of calibration tools. Required if Axis Calibration is the valid calibration method for the robot.
Standard toolkit	-	Content is defined in section Standard tools on page 406 .
Other tools and procedures may be required. See references to these procedures in the step-by-step instructions below.		These procedures include references to the tools required.

Deciding calibration routine

Decide which calibration routine to be used, based on the information in the table. Depending on which routine is chosen, action might be required prior to beginning the repair work of the robot, see the table.

	Action	Note
1	Decide which calibration routine to use for calibrating the robot. <ul style="list-style-type: none"> Reference calibration. External cable packages (DressPack) and tools can stay fitted on the robot. Fine calibration. All external cable packages (DressPack) and tools must be removed from the robot. 	
	<p>If the robot is to be calibrated with reference calibration:</p> <p>Find previous reference values for the axis or create new reference values. These values are to be used after the repair procedure is completed, for calibration of the robot.</p> <p>If no previous reference values exist, and no new reference values can be created, then reference calibration is not possible.</p>	<p>Follow the instructions given in the reference calibration routine on the FlexPendant to create reference values.</p> <p>Creating new values requires possibility to move the robot.</p> <p>Read more about reference calibration for Axis Calibration in Reference calibration routine on page 373.</p>
	<p>If the robot is to be calibrated with fine calibration:</p> <p>Remove all external cable packages (DressPack) and tools from the robot.</p>	

Continues on next page



4 Repair

4.7.1 Replacing the axis 1 gearbox

Continued

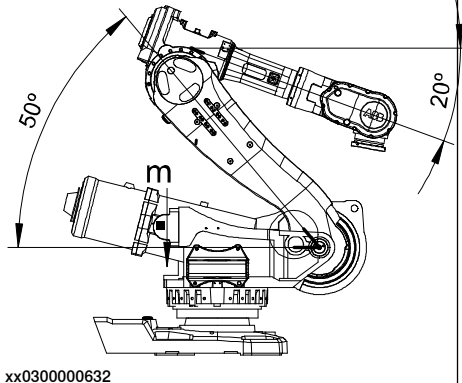

Removal, gearbox axis 1

Use this procedure to remove gearbox, axis 1.

	Action	Note
1	Decide which calibration routine to use, and take actions accordingly prior to beginning the repair procedure.	
2	Move the robot to its most stable position, shown in the figure to the right.	 <p>xx0300000632</p>
3	 <p>DANGER</p> <p>Turn off all:</p> <ul style="list-style-type: none"> • electric power supply • hydraulic pressure supply • air pressure supply <p>to the robot, before entering the robot working area.</p>	
4	Drain the axis 1 gearbox.	See Changing oil, axis-1 gearbox on page 155 .
5	Remove the complete arm system.	Detailed in section Removal, arm system on page 227 .
6	Unfasten the robot base from the foundation by removing the base attachment screws.	

Continues on next page

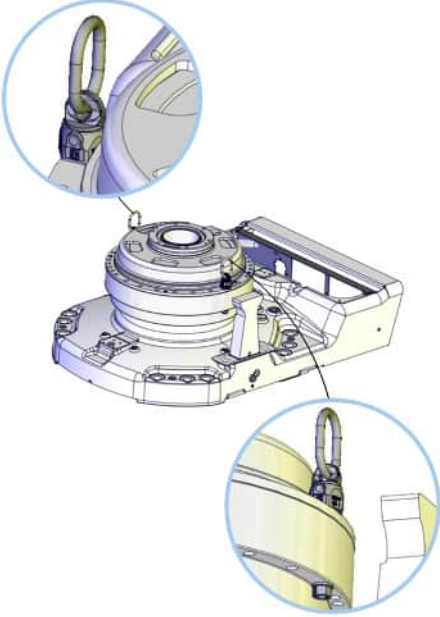
4.7.1 Replacing the axis 1 gearbox
Continued

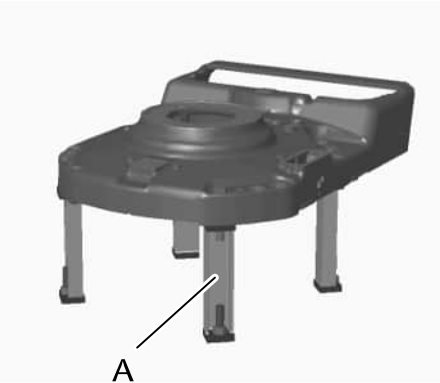
	Action	Note
7	<p>Attach the <i>lifting accessory, base and gear 1</i> and the <i>lifting tool (chain)</i> to the gearbox and base.</p>	 <p>xx1000001395</p> <p>Specified in Required equipment on page 328.</p>
8	<p> CAUTION</p> <p>The base and axis 1 gearbox weighs 300 kg + 200 Kg. All lifting accessories used must be sized accordingly!</p>	
9	<p>Lift the robot base including the axis 1 gearbox to allow the <i>base and gear 1 support</i> be fitted on each sides of the base.</p>	<p>Art. no. is specified in Required equipment on page 328.</p>
10	<p>Secure the support to the base and to the foundation. Make sure the base remains in a stable position before performing any work underneath the base!</p>	 <p>xx1000000364</p> <p>A Support base (4 pcs)</p>

Continues on next page



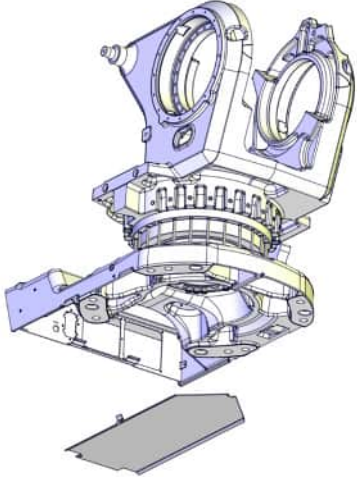
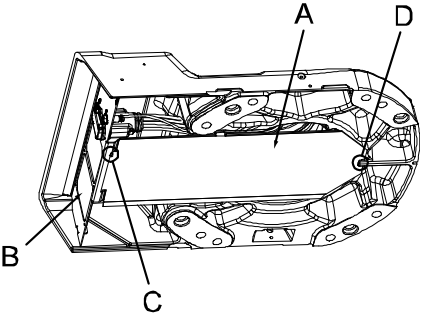
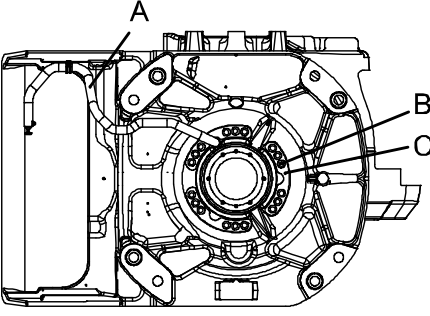

4 Repair

4.7.1 Replacing the axis 1 gearbox

Continued

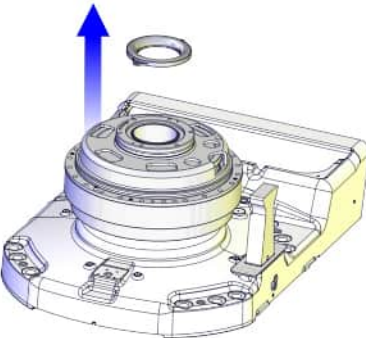
	Action	Note
11	<p>Remove the bottom plate from underneath the base in order to get access to the attachment screws.</p> <p>It may be necessary to also remove the rear connector plate.</p>	 <p>xx1000001385</p>  <p>xx0300000612</p> <ul style="list-style-type: none"> A Bottom plate B Rear connector plate C Attachment screw D Groove
12	<p>Unscrew the attachment screws and remove the washers.</p>	 <p>xx0200000227</p> <p>A view from below:</p> <ul style="list-style-type: none"> • A: Oil drain hose • B: Attachment screws, gearbox axis 1, 18 pcs • C: Washers, 3 pcs

Continues on next page

	Action	Note
13	Remove the cable guide in the center of gearbox 1 by unscrewing its attachment screws.	 <p>xx1000001387</p>
14	 CAUTION The gearbox weighs 200 Kg. All lifting accessories used must be sized accordingly!	
15	Lift the gearbox away with the already mounted lifting tools.	
16	Turn the gearbox, and remove the protection pipe by unscrewing two attachment screws.  Note Move the protective pipe over to the new gearbox.	 <p>xx1400000786</p>

Continues on next page

4 Repair

4.7.1 Replacing the axis 1 gearbox



Continued

Refitting, gearbox axis 1

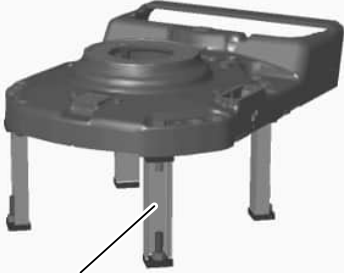
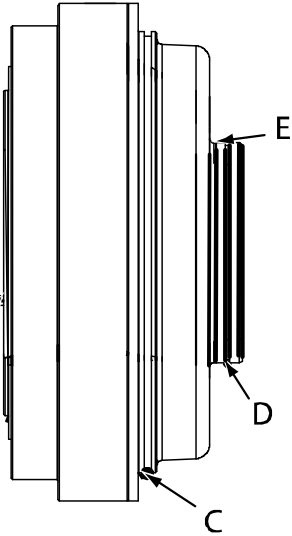
Use this procedure to refit gearbox, axis 1.

	Action	Note
1	Fit the <i>support, base and gear 1</i> to the base.	<p>Mounting of the support, base and gear 1 is detailed in section Removal, gearbox axis 1 on page 330.</p>  <p>xx1000000364</p> <p>A Support base (4 pcs)</p>
2	Make sure the two <i>o-rings</i> on the circumference of the gearbox are seated properly in their respective groove. Lubricate them with <i>grease</i> .	<p>Art no. is specified in Required equipment on page 328.</p>  <p>xx0200000055</p> <ul style="list-style-type: none">• A: Guide pin• C: O-ring 3HAB 3772-54• D: O-ring 3HAB 3772-55• E: Sealing ring 3HAC 11581-4

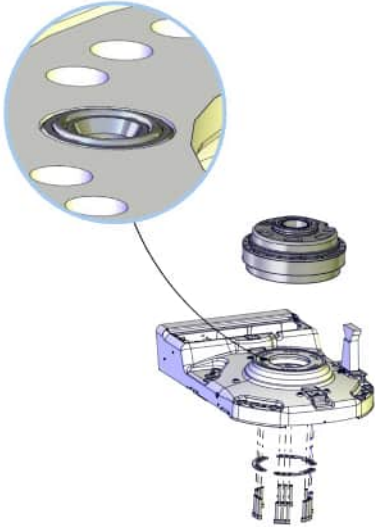
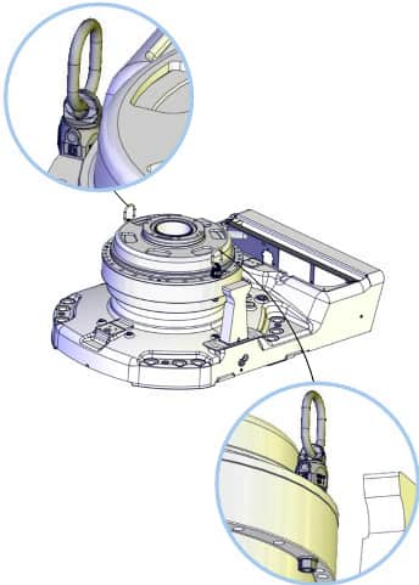
Continues on next page

	Action	Note
3	<p>Make sure the small o-ring around the oil hole is fitted properly!</p>	 <p>xx1000001392</p>
4	<p>Attach the <i>lifting accessory, base and gear 1</i> and the <i>lifting tool (chain)</i> to the gearbox.</p>	<p>Specified in Required equipment on page 328.</p>  <p>xx1000001395</p>
5	<p>Fit two <i>guide pins</i> in two of the attachment holes in the gearbox, parallel to each other.</p>	<p>Specified in Required equipment on page 328.</p>
6	<p> CAUTION</p> <p>The gearbox weighs 200 Kg. All lifting accessories used must be sized accordingly!</p>	

Continues on next page

4 Repair

4.7.1 Replacing the axis 1 gearbox

Continued

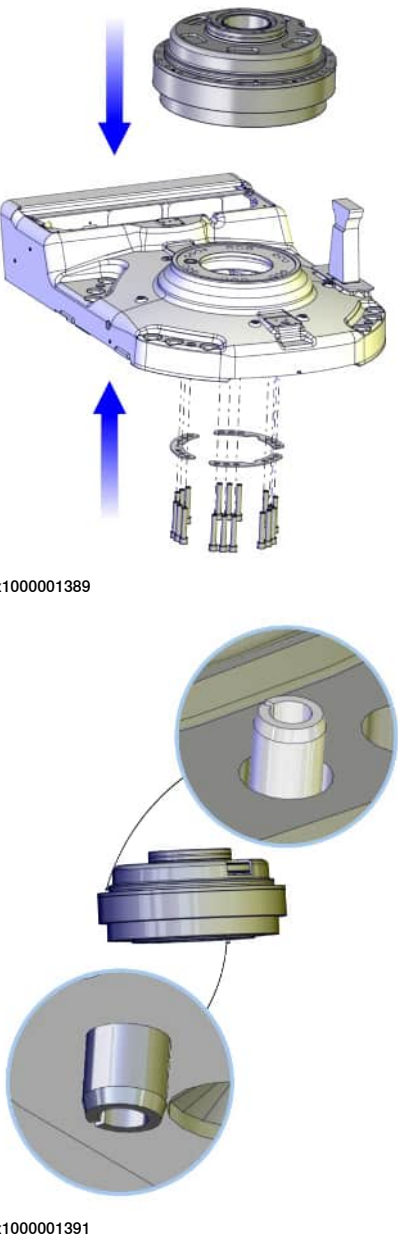
	Action	Note
7	<p>Lift the gearbox. Make sure the guide pin in the bottom face of the gearbox is properly aligned with the base.</p>	 <p>xx1000001389</p> <p>xx1000001391</p>
8	<p>Lift gearbox axis 1 onto the guide pins and lower it carefully to its mounting position.</p>	<p>Always use guide pins in pairs!</p>

Continues on next page

4.7.1 Replacing the axis 1 gearbox
Continued

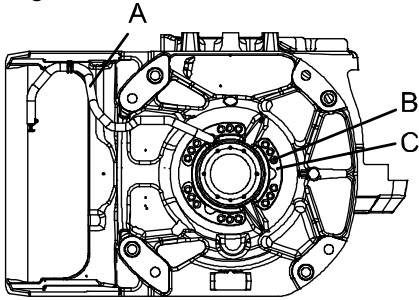
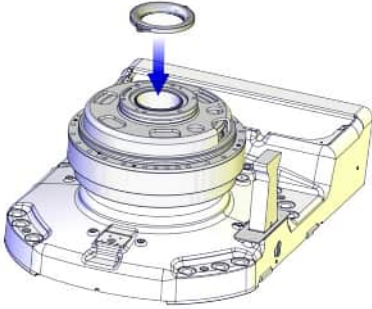



	Action	Note
9	Secure the gearbox with its <i>attachment screws</i> and washers.	<p>18 pcs, M16 x 90, 12.9 quality UN-BRAKO.</p> <p>Tightening torque: 300 Nm</p> <p>Reused screws may be used, providing they are lubricated as detailed in section Screw joints on page 402 before fitting.</p>  <p>xx0200000227</p> <p>A view from below:</p> <ul style="list-style-type: none"> • A: Oil drain hose • B: Attachment screws, gearbox axis 1, 18 pcs • C: Washers, 3 pcs
10	Refit the cable guide in the center of gearbox 1 with its attachment screws.	 <p>xx1000001393</p>

Continues on next page

4 Repair

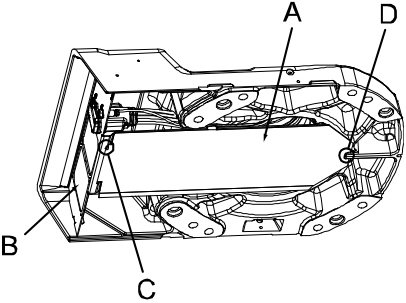
4.7.1 Replacing the axis 1 gearbox

Continued

	Action	Note
11	<p>Refit the bottom plate underneath the robot base by pushing it into the groove and fitting the attachment screw.</p> <p>If removed, also refit the rear connector plate.</p> <p> Note</p> <p>Direct the bends on the bottom plate downwards!</p>	<p>1 screw: M6 x 8.</p>  <p>xx0300000612</p> <ul style="list-style-type: none"> • A: Bottom plate • B: Rear connector plate • C: Attachment screw • D: Groove
12	<p> CAUTION</p> <p>The base and axis 1 gearbox weighs 300 kg + 200 Kg.</p> <p>All lifting accessories used must be sized accordingly!</p>	
13	<p>Lift the robot base and gearbox 1 and remove the base and gear support.</p>	
14	<p>Secure the base to the mounting site.</p>	<p>See Orienting and securing the robot on page 72.</p>
15	<p>Refit the complete arm system.</p> <p> CAUTION</p> <p>This is a complex task to be performed with utmost care in order to avoid injury or damage!</p>	<p>Detailed in section Refitting, arm system on page 229.</p>
16	<p>Perform a leak-down test.</p>	<p>See section Performing a leak-down test on page 184.</p>
17	<p>Refill the gearbox with oil.</p>	<p>See Changing oil, axis-1 gearbox on page 155.</p>
18	<p>Recalibrate the robot.</p>	<p>Axis Calibration is described in Calibrating with Axis Calibration method on page 372.</p> <p>General calibration information is included in section Calibration on page 359.</p>
19	<p> DANGER</p> <p>Make sure all safety requirements are met when performing the first test run. See Test run after installation, maintenance, or repair on page 108.</p>	

4.7.2 Replacement of gearbox axis 2

Location of gearbox

The gearbox for axis 2 is located in the lower arm rotational center, underneath the cover.

A more detailed view of the component and its position may be found in [Spare part lists on page 397](#).

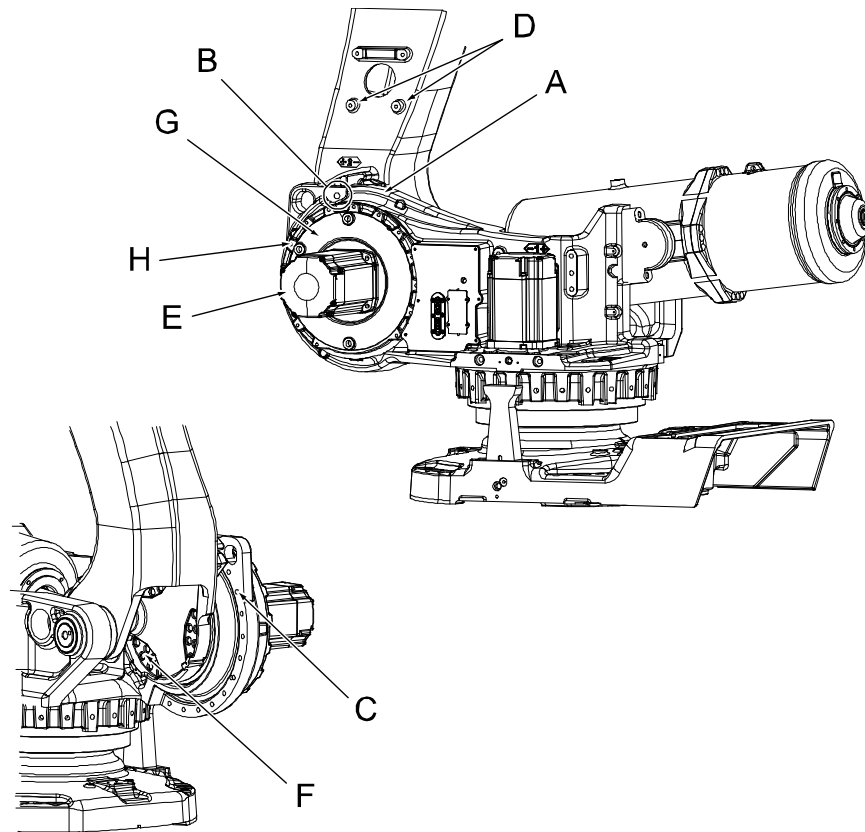

xx030000546

A	Gearbox, axis 2 (inside the frame)
B	Attachment hole for the locking screw, lower arm
C	Attachment holes inside of frame for the fixture, lower arm
D	Attachment holes for the fixture, lower arm
E	Motor, axis 2
F	Rear attachment screws, gearbox
G	Cover, axis 2
H	Attachment screws, cover

Continues on next page

4 Repair

4.7.2 Replacement of gearbox axis 2

Continued

Required equipment

Equipment	Art. no.	Note
Gearbox axis 2	For spare part number, see Spare part lists on page 397 .	Includes <ul style="list-style-type: none"> • gearbox • o-ring. Does not include "Sealing, axis 2/3"!
O-ring	3HAB3772-77	O-ring in gearbox, 1 pc.
O-ring	3HAB3772-73	O-ring in the cover, axis 2, 1 pc. Should be replaced if damaged!
Sealing, axis 2	3HAC020123-001	A new sealing must be used on each assembly!
Grease	3HAB3537-1	For lubricating o-rings.
Fixture lower arm	3HAC020729-001	
Lifting tool, gearbox axis 2	3HAC020386-001	
Guide pins M12 x 150	3HAC13056-2	For guiding the gearbox.
Guide pins M12 x 200	3HAC13056-3	For guiding the gearbox.
Guide pins, sealing ax 2/3, 80mm	3HAC14628-1	For guiding the sealing!
Guide pins, sealing ax 2/3, 100mm	3HAC14628-2	For guiding the sealing!
Gearbox crank, axis 2	3HAC020999-001	Used to turn the gear in correct position.
Standard toolkit	-	The contents are defined in section Standard tools on page 406 in part 2 of the Product manual.
Other tools and procedures may be required. See references to these procedures in the step-by-step instructions below.		These procedures include references to the tools required.

Deciding calibration routine

Decide which calibration routine to be used, based on the information in the table. Depending on which routine is chosen, action might be required prior to beginning the repair work of the robot, see the table.



	Action	Note
1	Decide which calibration routine to use for calibrating the robot. <ul style="list-style-type: none"> • Reference calibration. External cable packages (DressPack) and tools can stay fitted on the robot. • Fine calibration. All external cable packages (DressPack) and tools must be removed from the robot. 	

Continues on next page

Action	Note
<p>If the robot is to be calibrated with reference calibration: Find previous reference values for the axis or create new reference values. These values are to be used after the repair procedure is completed, for calibration of the robot.</p> <p>If no previous reference values exist, and no new reference values can be created, then reference calibration is not possible.</p>	<p>Follow the instructions given in the reference calibration routine on the FlexPendant to create reference values.</p> <p>Creating new values requires possibility to move the robot.</p> <p>Read more about reference calibration for Axis Calibration in Reference calibration routine on page 373.</p>
<p>If the robot is to be calibrated with fine calibration: Remove all external cable packages (DressPack) and tools from the robot.</p>	

Removal, gearbox axis 2

The procedure below details how to remove the gearbox, axis 2.



	Action	Note
1	Decide which calibration routine to use, and take actions accordingly prior to beginning the repair procedure.	
2	 DANGER Turn off all: <ul style="list-style-type: none"> • electric power supply to the robot • hydraulic pressure supply to the robot • air pressure supply to the robot Before entering the robot working area.	
3	Secure the lower arm with the special fixture equipment according to section Securing the lower arm on page 268 .	
4	<p>Unload the balancing device in order to make the piston rod and front ear adjustable when pulling the front shaft out.</p>  DANGER Handling the tool incorrectly will cause serious injury. Read and follow enclosed user instructions for the tool.	Detailed in section Unloading the balancing device on page 286 .
5	Drain the gearbox, axis 2.	Notice! Time-consuming activity! Detailed in section Changing oil, axis-2 gearbox on page 158 .
6	Remove the motor, axis 2.	Detailed in section Removal, motor on page 301 .
7	Remove the <i>rear attachment screws, gearbox</i> from inside of the lower arm.	Shown in the figure Location of gearbox on page 339 !
8	Remove the <i>cover, axis 2</i> by unscrewing its 14 attachment screws.	Shown in the figure Location of gearbox on page 339 !

Continues on next page

4 Repair

4.7.2 Replacement of gearbox axis 2

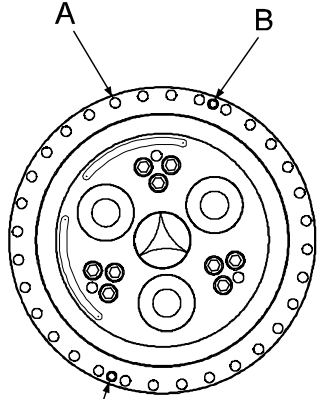
Continued



	Action	Note
9	Remove the front attachment screws, gearbox, shown in the figure to the right.	 <p>xx0300000550</p> <ul style="list-style-type: none"> • A: Front attachment screws, gearbox (32 pcs) • B: M12 holes for pressing the gearbox out
10	Fit two <i>guide pins</i> in 180° relation to each other in the empty holes of the front gearbox attachment screws.	Art. no. is specified in Required equipment on page 340!
11	If required, apply two M12 screws to the holes, shown in the figure above, to press it free.	
12	Fit the <i>lifting tool, gearbox axis 2</i> to the gearbox.	Art. no. is specified in Required equipment on page 340!
13	 CAUTION The gearbox weighs 100 kg! All lifting equipment used must be sized accordingly!	
14	Remove the gearbox axis 2 using an overhead crane or similar, with guidance from the mounted guide pins.	
15	Remove the sealing from the lower arm.	

Refitting, gearbox axis 2

The procedure below details how to refit the gearbox axis 2.

	Action	Note
1	 DANGER Turn off all: <ul style="list-style-type: none"> • electric power supply to the robot • hydraulic pressure supply to the robot • air pressure supply to the robot Before entering the robot working area.	

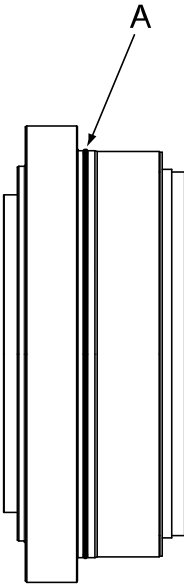
Continues on next page

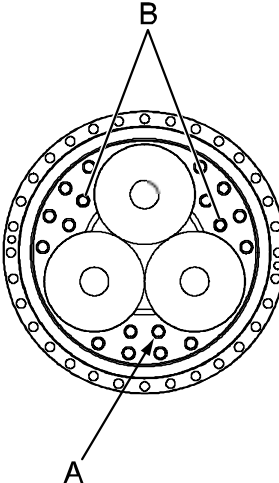

	Action	Note
2	<p>Make sure the o-ring is fitted to the gearbox as shown in the figure to the right. Lightly lubricate it with <i>grease</i>.</p>	<p>Art. no. is specified in Required equipment on page 340!</p>  <p>xx0300000551</p> <ul style="list-style-type: none"> • A: O-ring, gearbox axis 2
3	<p>Fit the <i>lifting tool, gearbox axis 2</i> to the gearbox.</p>	<p>Art. no. is specified in Required equipment on page 340!</p>
4	<p>Fit the new <i>sealing, axis 2/3</i> to the gearbox.</p>	<p>Art. no. is specified in Required equipment on page 340!</p>
5	<p>Fit the <i>guide pins, sealing axis 2/3</i> to the rear of the gearbox, axis 2 to hold the sealing in place.</p> <p>Use the attachment holes shown in the figure to the right!</p> <p> Note</p> <p>Do not remove the guide pins for the sealing until the rear attachment screws are secured.</p>	 <p>xx0300000552</p> <ul style="list-style-type: none"> • A: Rear attachment screws, gearbox (18 pcs) • B: Holes for the guide pins, sealing axis 2/3 on the gearbox

Continues on next page

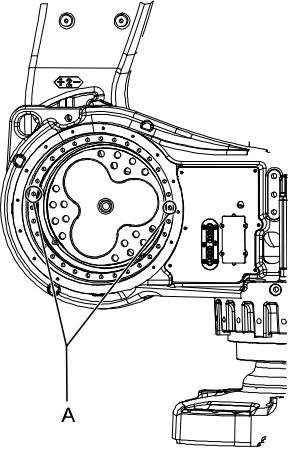

4 Repair

4.7.2 Replacement of gearbox axis 2

Continued

	Action	Note
6	Fit two <i>guide pins</i> , M12 in 180° relation to each other in the frame, in the screw holes for the gearboxes front attachment screws.	<p>Art. no. is specified in Required equipment on page 340!</p>  <p>xx0300000554</p> <ul style="list-style-type: none"> A: Attachments in the frame for the two guiding pins
7	<p> CAUTION</p> <p>The gearbox weighs 100 kg! All lifting equipment used must be sized accordingly!</p>	
8	Lift the gearbox to its mounting position and slide it onto the guiding pins attached in the frame, through the front attachment screw holes.	
9	Align the gearbox attachment screw holes to the hole patterns in the lower arm, with help from the guide pins, sealing axis 2/3. If necessary, use a <i>gearbox crank</i> to turn the gear! Use the gearbox crank with caution! The gearbox may be damaged if the crank is inserted too far into the gear!	Art. no. is specified in Required equipment on page 340!
10	Fit the gearbox with guidance from the guide pins and slide it into position. If necessary, use the front gearbox attachment screws to press the gearbox into place.	
11	Remove the lifting tool from the gearbox.	
12	Insert and secure 30 of the 32 <i>front attachment screws</i> , gearbox. Remove the guide pins, M12 and refit the two remaining screws.	32 pcs: M12 x 60, tightening torque: 115 Nm.
13	Lubricate the <i>o-ring</i> at the sealing surface of the cover, axis 2. Replace it if damaged.	Art. no. is specified in Required equipment on page 340.
14	Refit the <i>cover</i> , axis 2 to the frame with the <i>attachment screws</i> , cover.	Shown in the figure Location of gearbox on page 339.

Continues on next page

	Action	Note
15	Insert and secure 16 of the 18 <i>rear attachment screws, gearbox</i> on the inside of the lower arm.	Shown in the figure Location of gearbox on page 339! 18 pcs: M16 x 50, tightening torque: 300 Nm. Reused screws may be used, providing they are lubricated as detailed in section Screw joints on page 402 before fitting.
16	Remove the guide pins, sealing axis 2/3, and tighten the two remaining screws as detailed above.	
17	Refit the motor.	Detailed in section Refitting, motor on page 302 .
18	Perform a leak-down test.	Detailed in section Performing a leak-down test on page 184 .
19	Refill the gearbox with oil.	Detailed in section Changing oil, axis-2 gearbox on page 158 .
20	Restore the balancing device.  DANGER Handling the tool incorrectly will cause serious injury. Read and follow enclosed user instructions for the tool.	Detailed in section Restoring the balancing device on page 287 .
21	Remove the fixture, lower arm.	
22	Remove the locking screw, lower arm, and re-attach it to the fixture tool.	
23	Refit any mechanical stops if such were removed during disassembly.	
24	Refit any equipment to the turning disk if such was removed during disassembly.	
25	Recalibrate the robot.	Axis Calibration is described in Calibrating with Axis Calibration method on page 372 . General calibration information is included in section Calibration on page 359 .
26	 DANGER Make sure all safety requirements are met when performing the first test run. See Test run after installation, maintenance, or repair on page 108 .	

4 Repair

4.7.3 Replacement of gearbox, axis 3

4.7.3 Replacement of gearbox, axis 3

Location of gearbox

The axis 3 gearbox is located in the upper arm rotational center as shown in the figure below.

A more detailed view of the component and its position may be found in chapter *Exploded views in Product manual, spare parts - IRB 7600*.

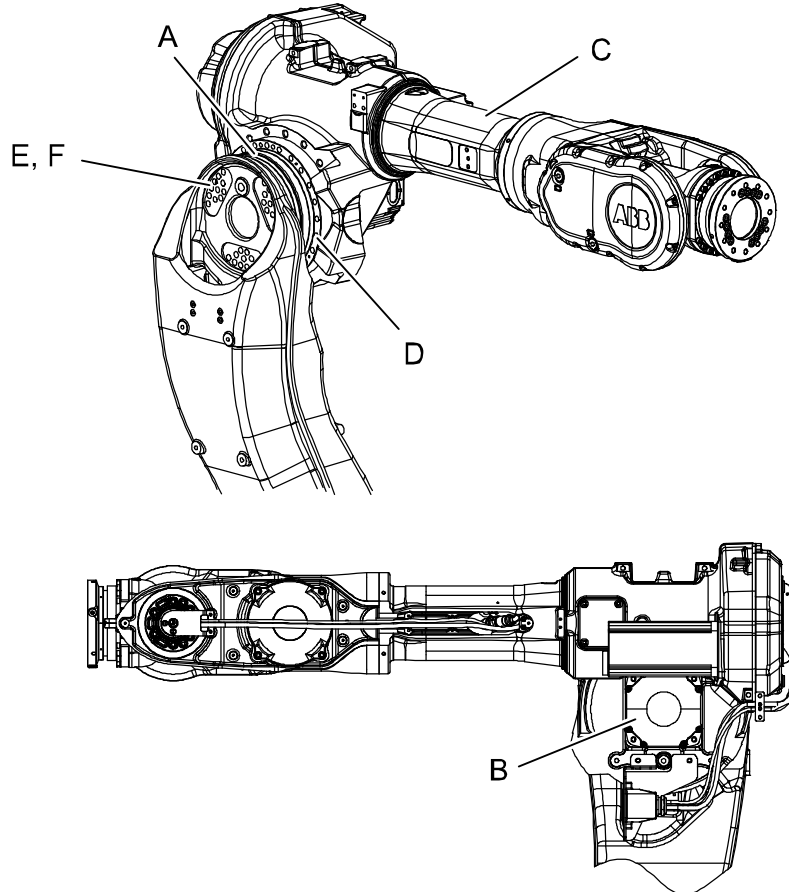

xx0200000194

A	Gearbox, axis 3
B	Motor, axis 3
C	Upper arm
D	Attachment screws, M12x60 quality Gleitmo (24 pcs)

Required equipment

Equipment, etc.	Art. no.	Note
Gearbox	For spare part number, see Spare part lists on page 397 .	Includes <ul style="list-style-type: none">• gearbox• o-ring. Does not include the sealing, axis 2/3!

Continues on next page

Equipment, etc.	Art. no.	Note
O-ring	3HAB3772-68	1 pc on the gearbox. Replace if damaged.
Grease	3HAC042536-001	For lubricating the o-rings.
Sealing, axis 3	3HAC17212-1	A new sealing must be used on each assembly!
Mechanical stop axis 3	3HAC12708-1	Used to secure the upper arm. Use attachment screws 3HAB3409-86 (M16 x 60).
Washers (for mechanical stop axis 3)	3HAA1001-186	
Bolt, M16x60 (for mechanical stop axis 3)	3HAB3409-86	
Lifting accessory RV2	3HAC13698-1	For lifting the gearbox.
Lifting eye M12	3HAC14457-3	
Guide pins M12 x 200	3HAC13056-3	For guiding the gearbox. Use guides in pairs!
Guide pins M12 x 250	3HAC13056-4	For guiding the gearbox. Use guides in pairs!
Guide pins, sealing ax 2/3, 80mm	3HAC14628-1	For guiding the axis-3 sealing. Use guides in pairs!
Guide pins, sealing ax 2/3, 100mm	3HAC14628-2	For guiding the axis-3 sealing. Use guides in pairs!
Standard toolkit	-	Content is defined in section Standard tools on page 406 .
Calibration tool box, Axis Calibration	3HAC055412-001	Delivered as a set of calibration tools. Required if Axis Calibration is the valid calibration method for the robot.
Other tools and procedures may be required. See references to these procedures in the step-by-step instructions below.		These procedures include references to the tools required.

Deciding calibration routine

Decide which calibration routine to be used, based on the information in the table. Depending on which routine is chosen, action might be required prior to beginning the repair work of the robot, see the table.

	Action	Note
1	<p>Decide which calibration routine to use for calibrating the robot.</p> <ul style="list-style-type: none"> Reference calibration. External cable packages (DressPack) and tools can stay fitted on the robot. Fine calibration. All external cable packages (DressPack) and tools must be removed from the robot. 	

Continues on next page

4 Repair



4.7.3 Replacement of gearbox, axis 3

Continued



Action	Note
<p>If the robot is to be calibrated with reference calibration: Find previous reference values for the axis or create new reference values. These values are to be used after the repair procedure is completed, for calibration of the robot.</p> <p>If no previous reference values exist, and no new reference values can be created, then reference calibration is not possible.</p>	<p>Follow the instructions given in the reference calibration routine on the FlexPendant to create reference values.</p> <p>Creating new values requires possibility to move the robot.</p> <p>Read more about reference calibration for Axis Calibration in Reference calibration routine on page 373.</p>
<p>If the robot is to be calibrated with fine calibration: Remove all external cable packages (DressPack) and tools from the robot.</p>	

Removal, gearbox axis 3

The procedure below details how to remove gearbox, axis 3.

	Action	Note
1	Decide which calibration routine to use, and take actions accordingly prior to beginning the repair procedure.	
2	 DANGER Turn off all: <ul style="list-style-type: none"> • electric power supply to the robot • hydraulic pressure supply to the robot • air pressure supply to the robot Before entering the robot working area.	
3	Secure the upper arm in a horizontal position using round slings.	Art. no. is specified in Required equipment on page 346 .
4	Remove the <i>motor, axis 3</i> .	Detailed in section Removal, motor on page 307 .  Note When removing the motor axis 3, the brake on axis 3 is released. Make sure the upper arm is secured and disabled to move!
5	Remove the <i>upper arm</i> .	Detailed in section Removal, upper arm on page 245 .
6	Remove the <i>sealing, axis 2/3</i> between the gearbox and lower arm.	On reassembly a new sealing must be used! Art. no. is specified in Required equipment on page 346 .
7	Place the upper arm safely on a workbench, in a fixture or similar.	

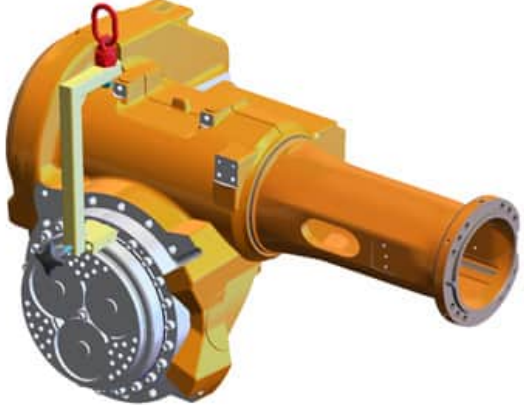
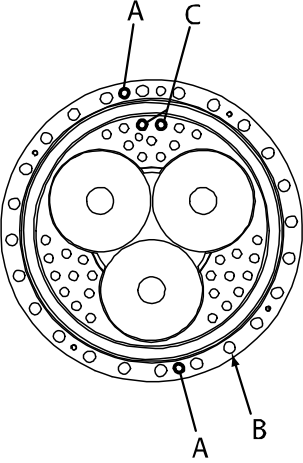
Continues on next page

	Action	Note
8	Remove the <i>attachment screws, gearbox</i> .	Shown in the figure Location of gearbox on page 346 .
9	Fit the two <i>guide pins</i> in 180° relation to each other in the gearbox attachment screw holes.	Art. no. is specified in Required equipment on page 346 .
10	Fit the Lifting accessory RV2 according to figure.	 <p data-bbox="890 913 995 936">xx0900000113</p>
11	If required, use screws in the holes (A) shown in the figure to the right to press the gearbox free.	 <p data-bbox="890 1435 995 1458">xx0200000201</p> <ul data-bbox="922 1473 1437 1619" style="list-style-type: none"> • A: M12 holes for pressing the gearbox out • B: Attachment screw holes, gearbox - upper arm • C: Attachment screw holes, gearbox - lower arm
12	 CAUTION The gearbox weighs 60 kg! All lifting accessories used must be sized accordingly!	
13	Remove the gearbox, with guidance from the guide pins, using an overhead crane or similar.	

Continues on next page



4 Repair

4.7.3 Replacement of gearbox, axis 3

Continued

Refitting, gearbox axis 3

The procedure below details how to refit gearbox, axis 3.

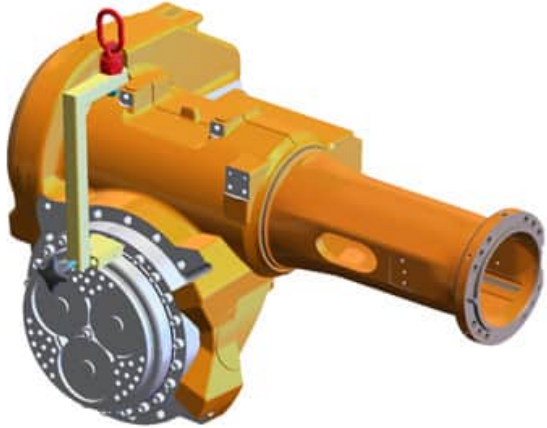
	Action	Note
1	 DANGER Turn off all: <ul style="list-style-type: none">• electric power supply to the robot• hydraulic pressure supply to the robot• air pressure supply to the robot Before entering the robot working area.	
2	Turn the upper arm in such a position that the gear mating surface faces upwards.	
3	Fit two <i>guide pins</i> in 180° relation to each other in the holes in the upper arm, used for the gearbox attachment screws.	Art. no. is specified in Required equipment on page 346 .
4	 CAUTION The gearbox weighs 60 kg! All lifting accessories used must be sized accordingly!	
5	Fit the lifting accessory RV2 according to figure.	 xx0900000113

Continues on next page

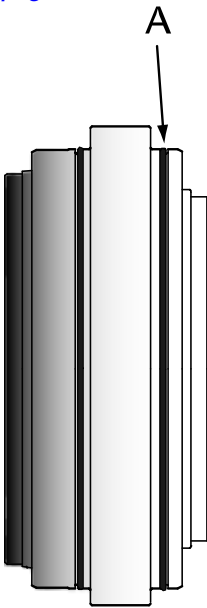
	Action	Note
6	<p>Make sure the <i>o-rings</i> are fitted to the gearbox. Apply <i>grease</i> to the o-rings to make sure they stick in their grooves during assembly.</p> <p>Replace if damaged!</p>	<p>Art. no. is specified in Required equipment on page 346.</p>  <p>xx0200000173</p> <ul style="list-style-type: none"> A: O-ring, gearbox axis 3
7	Lift the gearbox to its mounting position.	
8	Turn the gearbox to align the attachment screw holes with those in the upper arm.	
9	Fit the gearbox onto the guide pins and slide it into position.	Make sure the o-rings are seated properly and the gearbox correctly oriented!
10	Remove the lifting tool.	
11	<p>Secure the gearbox with 22 of the 24 gearbox attachment screws.</p> <p>Remove the guide pins and tighten the remaining two screws.</p>	<p>24 pcs: M12 x 60.</p> <p>Tightening torque: 115 Nm.</p> <p>Reused screws may be used, providing they are lubricated as detailed in section Screw joints on page 402 before fitting.</p>
12	Refit the upper arm with a new <i>sealing, axis 2/3</i> .	<p>Art. no. is specified in Required equipment on page 346.</p> <p>Detailed in section Refitting, upper arm on page 247.</p>
13	Refit the motor.	Detailed in section Refitting, motor on page 308 .
14	Recalibrate the robot!	<p>Axis Calibration is described in Calibrating with Axis Calibration method on page 372.</p> <p>General calibration information is included in section Calibration on page 359.</p>

Continues on next page

4 Repair

4.7.3 Replacement of gearbox, axis 3

Continued

	Action	Note
15	 DANGER Make sure all safety requirements are met when performing the first test run. See Test run after installation, maintenance, or repair on page 108 .	

4.7.4 Replacement of gearbox, axis 6

Location of gearbox

The axis 6 gearbox is located in the center of the wrist unit as shown in the figure below.

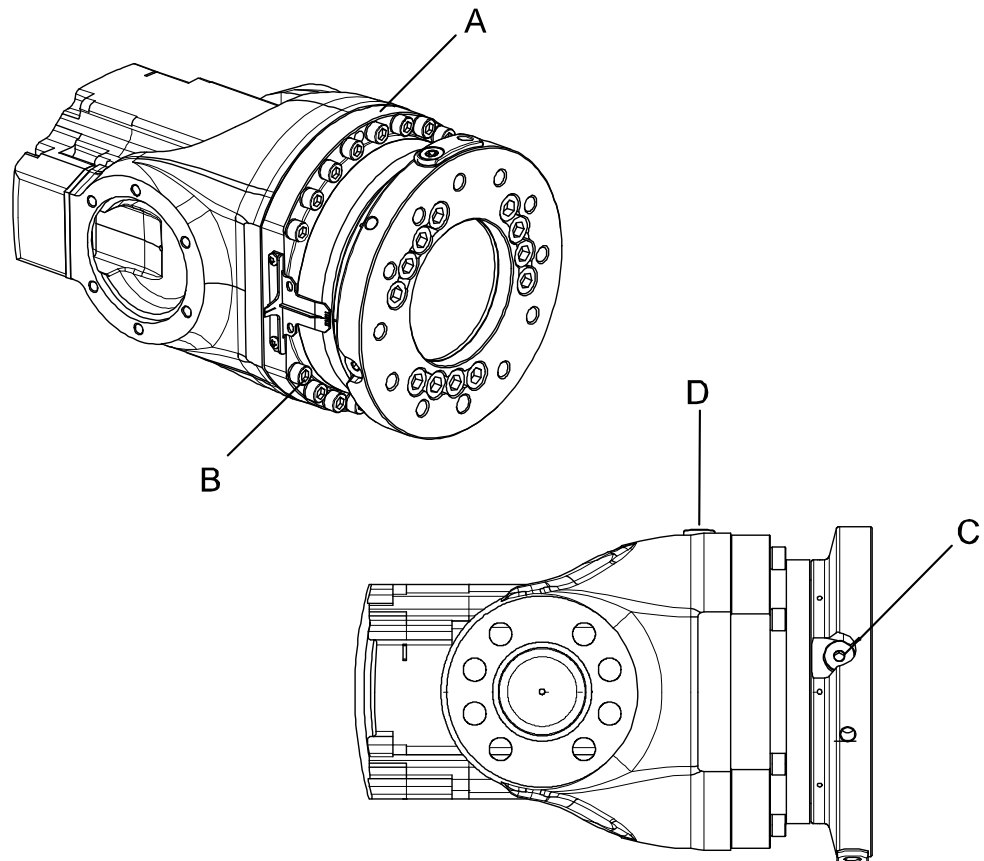

xx020000219

A	Gearbox, axis 6
B	Attachment screws and washers, gearbox (18 pcs)
C	Oil plug, draining
D	Oil plug, filling
-	O-ring (not shown in figure)

Required equipment

Equipment, etc.	Article number	Note
Gearbox	For spare part number, see Spare part lists on page 397 .	Includes o-ring
Washers	3HAA1001-172	Not included in gearbox! Replace when damaged.

Continues on next page

4 Repair

4.7.4 Replacement of gearbox, axis 6

Continued

Equipment, etc.	Article number	Note
O-ring	3HAB3772-58	Located between the gearbox and the turning disk. Must be replaced when reassembling gearbox.
O-ring	3HAB3772-57	For type 2 of the gearbox. 164.7x3.53 Must be replaced when reassembling gearbox.
O-ring	3HAB3772-64	For type 2 of the gearbox. 150.0x2.0 Must be replaced when reassembling gearbox.
O-ring	3HAB3772-61	For type 2 of the gearbox. 12 pcs, 13.1x1.6 Must be replaced when reassembling gearbox.
Grease	3HAC042536-001	For lubricating the o-ring.
Flange sealant	12340011-116	Loctite 574
Standard toolkit	-	Content is defined in section Standard tools on page 406 .
Calibration tool box, Axis Calibration	3HAC055412-001	Delivered as a set of calibration tools. Required if Axis Calibration is the valid calibration method for the robot.
Other tools and procedures may be required. See references to these procedures in the step-by-step instructions below.		These procedures include references to the tools required.

Deciding calibration routine

Decide which calibration routine to be used, based on the information in the table. Depending on which routine is chosen, action might be required prior to beginning the repair work of the robot, see the table.

	Action	Note
1	Decide which calibration routine to use for calibrating the robot. <ul style="list-style-type: none">Reference calibration. External cable packages (DressPack) and tools can stay fitted on the robot.Fine calibration. All external cable packages (DressPack) and tools must be removed from the robot.	

Continues on next page

Action	Note
<p>If the robot is to be calibrated with reference calibration: Find previous reference values for the axis or create new reference values. These values are to be used after the repair procedure is completed, for calibration of the robot.</p> <p>If no previous reference values exist, and no new reference values can be created, then reference calibration is not possible.</p>	<p>Follow the instructions given in the reference calibration routine on the FlexPendant to create reference values.</p> <p>Creating new values requires possibility to move the robot.</p> <p>Read more about reference calibration for Axis Calibration in Reference calibration routine on page 373.</p>
<p>If the robot is to be calibrated with fine calibration: Remove all external cable packages (DressPack) and tools from the robot.</p>	

Removal, gearbox

The procedure below details how to remove gearbox, axis 6.

	Action	Note
1	Decide which calibration routine to use, and take actions accordingly prior to beginning the repair procedure.	
2	 DANGER Turn off all: <ul style="list-style-type: none"> • electric power supply to the robot • hydraulic pressure supply to the robot • air pressure supply to the robot Before entering the robot working area.	
3	Drain the oil from gearbox, axis 6.	Detailed in the section Changing oil, axis-6 gearbox on page 170 .
4	Remove the <i>turning disc</i> .	Detailed in the section Removing, turning disk on page 232 .
5	Remove the gearbox by unscrewing its <i>attachment screws</i> .	Shown in the figure Location of gearbox on page 353 .

Continues on next page

4 Repair

4.7.4 Replacement of gearbox, axis 6

Continued

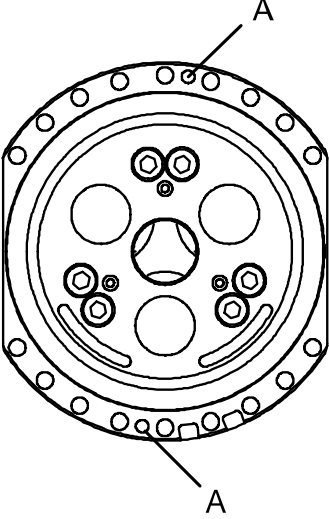
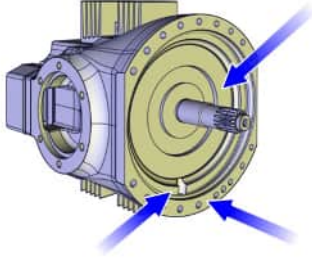
	Action	Note
6	If required, apply M8 screws to the holes shown in the figure beside to press the gearbox out.	 <p>xx0200000220</p> <ul style="list-style-type: none"> A: M8 holes for pressing out the gearbox
	<p><i>Foundry Plus:</i> Remove old Loctite 574 flange sealant residues and other contamination from the contact surfaces.</p>	 <p>xx1400001123</p>
7	Remove the gearbox axis 6 by lifting it out carefully.	Be careful not to damage the motor pinion!

Refitting, gearbox

The procedure below details how to refit gearbox, axis 6.

	Action	Note
1	 <p>DANGER</p> <p>Turn off all:</p> <ul style="list-style-type: none"> electric power supply to the robot hydraulic pressure supply to the robot air pressure supply to the robot <p>Before entering the robot working area.</p>	

Continues on next page

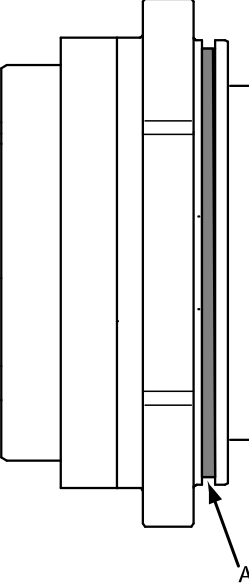
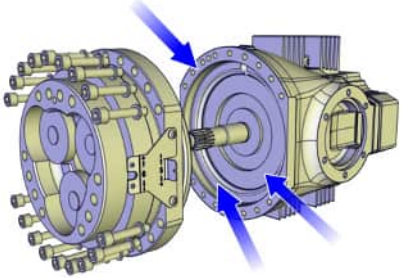
	Action	Note
2	Make sure the <i>o-ring</i> is fitted to the rear of the gearbox. Lubricate the o-ring with <i>grease</i> .	<p>Article number is specified in Required equipment on page 353.</p>  <p>xx0200000221</p> <ul style="list-style-type: none"> A: O-ring, gearbox axis 6
3	Release the holding brake of motor axis 6.	Detailed in the section Manually releasing the brakes on page 64 .
4	Foundry Plus: Apply Loctite 574 flange sealant on the contact surface.	 <p>xx1400001122</p>
5	Insert the <i>gearbox, axis 6</i> into the wrist unit.	<p>Article number is specified in Required equipment on page 353.</p> <p>Shown in the figure Location of gearbox on page 353.</p> <p>Make sure the gears of the gearbox mate with the gears of the motor!</p>
6	Secure the gearbox with the <i>attachment screws and washers</i> .	<p>Shown in the figure Location of gearbox on page 353.</p> <p>8 pcs or 18 pcs (depending on wrist version): M8 x 40, 12.9 quality Gleitmo, Tightening torque: 30 Nm.</p> <p>Reused screws may be used, providing they are lubricated as detailed in section Screw joints on page 402 before fitting.</p>
7	Refit the <i>turning disc</i> .	Detailed in the section Refitting, turning disk on page 233 .

Continues on next page

4 Repair

4.7.4 Replacement of gearbox, axis 6

Continued

	Action	Note
8	Perform a <i>leak-down test</i> .	Detailed in the section Performing a leak-down test on page 184 .
9	Refill the gearbox with oil.	Detailed in the section Changing oil, axis-6 gearbox on page 170 .
10	Re-calibrate the robot.	Axis Calibration is described in Calibrating with Axis Calibration method on page 372 . General calibration information is included in section Calibration on page 359 .
11	 DANGER Make sure all safety requirements are met when performing the first test run. See Test run after installation, maintenance, or repair on page 108 .	

5 Calibration

5.1 Introduction to calibration

5.1.1 Introduction and calibration terminology

Calibration information

This chapter includes general information about the recommended calibration methods and also the detailed procedures for updating the revolution counters, checking the calibration position etc.

Detailed instructions of how to perform Axis Calibration are given on the FlexPendant during the calibration procedure. To prepare calibration with Axis Calibration method, see [Calibrating with Axis Calibration method on page 372](#).

Calibration terminology

Term	Definition
Calibration method	A collective term for several methods that might be available for calibrating the ABB robot. Each method contains calibration routines.
Synchronization position	Known position of the complete robot where the angle of each axis can be checked against visual synchronization marks.
Calibration position	Known position of the complete robot that is used for calibration of the robot.
Standard calibration	A generic term for all calibration methods that aim to move the robot to calibration position.
Fine calibration	A calibration routine that generates a new zero position of the robot.
Reference calibration	<p>A calibration routine that in the first step generates a reference to current zero position of the robot. The same calibration routine can later on be used to recalibrate the robot back to the same position as when the reference was stored.</p> <p>This routine is more flexible compared to fine calibration and is used when tools and process equipment are installed.</p> <p>Requires that a reference is created before being used for recalibrating the robot.</p> <p>Requires that the robot is dressed with the same tools and process equipment during calibration as during creation of the reference values.</p>
Update revolution counter	A calibration routine to make a rough calibration of each manipulator axis.
Synchronization mark	Visual marks on the robot axes. When marks are aligned, the robot is in synchronization position.

5 Calibration

5.1.2 Calibration methods

5.1.2 Calibration methods

Overview

This section specifies the different types of calibration and the calibration methods that are supplied by ABB.

Types of calibration

Type of calibration	Description	Calibration method
Standard calibration	<p>The calibrated robot is positioned at calibration position.</p> <p>Standard calibration data is found on the SMB (serial measurement board) or EIB in the robot. For robots with RobotWare 5.04 or older, the calibration data is delivered in a file, calib.cfg, supplied with the robot at delivery. The file identifies the correct resolver/motor position corresponding to the robot home position.</p>	<p>Axis Calibration</p> <p>Levelmeter calibration (alternative method)</p>
Absolute accuracy calibration (optional)	<p>Based on standard calibration, and besides positioning the robot at synchronization position, the Absolute accuracy calibration also compensates for:</p> <ul style="list-style-type: none"> Mechanical tolerances in the robot structure Deflection due to load <p>Absolute accuracy calibration focuses on positioning accuracy in the Cartesian coordinate system for the robot.</p> <p>Absolute accuracy calibration data is found on the serial measurement board (SMB) or other robot memory.</p> <p>For robots with RobotWare 5.05 or older, the absolute accuracy calibration data is delivered in a file, absacc.cfg, supplied with the robot at delivery. The file replaces the calib.cfg file and identifies motor positions as well as absolute accuracy compensation parameters.</p> <p>A robot calibrated with Absolute accuracy has a sticker next to the identification plate of the robot (IRC5).</p> <p>A robot calibrated with Absolute accuracy has the option information printed on its name plate (OmniCore).</p> <p>To regain 100% Absolute accuracy performance, the robot must be recalibrated for absolute accuracy after repair or maintenance that affects the mechanical structure.</p> <div style="border: 1px solid black; padding: 5px; margin-top: 10px;">  <div style="display: inline-block; vertical-align: middle;"> <p>ABSOLUTE ACCURACY</p> <p style="font-size: small;">3HAC 14257-1</p> </div> </div> <p>xx0400001197</p>	<p>CalibWare</p>

Continues on next page

Type of calibration	Description	Calibration method
Optimization	<p>Optimization of TCP reorientation performance. The purpose is to improve reorientation accuracy for continuous processes like welding and gluing.</p> <p>Wrist optimization will update standard calibration data for axes 4 and 5.</p>	Wrist Optimization

Brief description of calibration methods

Axis Calibration method

Axis Calibration is a standard calibration method for calibration of IRB 6650S. It is the recommended method in order to achieve proper performance.

The following routines are available for the Axis Calibration method:

- Fine calibration
- Update revolution counters
- Reference calibration

The calibration equipment for Axis Calibration is delivered as a toolkit.

An introduction to the calibration method is given in this manual, see [Calibrating with Axis Calibration method on page 372](#).

The actual instructions of how to perform the calibration procedure and what to do at each step is given on the FlexPendant. You will be guided through the calibration procedure, step by step.

Wrist Optimization method

Wrist Optimization is a method for improving reorientation accuracy for continuous processes like welding and gluing and is a complement to the standard calibration method.

The actual instructions of how to perform the wrist optimization procedure is given on the FlexPendant.

Levelmeter calibration - alternative method

Levelmeter calibration is referred to as the alternative method for calibration of ABB robots because of the less accurate values obtained during calibration. The method uses the same principles as Calibration Pendulum, but does not have as good of mechanical tolerances to the toolkit parts as the standard method with Calibration Pendulum.

This method may, after calibration, require modifications in the robot program and is therefore not recommended.

The calibration equipment (Levelmeter 2000) for levelmeter calibration is ordered as separate parts for each robot, and includes the *Operating manual - Levelmeter Calibration*, which describes the method and the different routines further.

CalibWare - Absolute Accuracy calibration

The CalibWare tool guides through the calibration process and calculates new compensation parameters. This is further detailed in the *Application manual - CalibWare Field*.

Continues on next page

5 Calibration

5.1.2 Calibration methods

Continued

If a service operation is done to a robot with the option Absolute Accuracy, a new absolute accuracy calibration is required in order to establish full performance. For most cases after replacements that do not include taking apart the robot structure, standard calibration is sufficient.

The Absolute Accuracy option varies according to the robot mounting position. This is printed on the robot name plate for each robot. The robot must be in the correct mounting position when it is recalibrated for absolute accuracy.

References

Article numbers for the calibration tools are listed in the section [Special tools on page 407](#).

5.1.3 When to calibrate

When to calibrate

The system must be calibrated if any of the following situations occur.

The resolver values are changed

If resolver values are changed, the robot must be re-calibrated using the calibration methods supplied by ABB. Calibrate the robot carefully with standard calibration, according to information in this manual.

If the robot has *absolute accuracy* calibration, it is also recommended, but not always necessary to calibrate for new absolute accuracy.

The resolver values will change when parts affecting the calibration position are replaced on the robot, for example motors or parts of the transmission.

The revolution counter memory is lost

If the revolution counter memory is lost, the counters must be updated. See [Updating revolution counters on page 366](#). This will occur when:

- The battery is discharged
- A resolver error occurs
- The signal between a resolver and measurement board is interrupted
- A robot axis is moved with the control system disconnected

The revolution counters must also be updated after the robot and controller are connected at the first installation.

The robot is rebuilt

If the robot is rebuilt, for example, after a crash or when the reachability of a robot is changed, it needs to be re-calibrated for new resolver values.

If the robot has *absolute accuracy* calibration, it needs to be calibrated for new absolute accuracy.

5 Calibration

5.2.1 Synchronization marks and synchronization position for axes

5.2 Synchronization marks and axis movement directions

5.2.1 Synchronization marks and synchronization position for axes

Introduction

This section shows the position of the synchronization marks and the synchronization position for each axis.

Synchronization marks, IRB 6650S

The figure shows IRB 6600, but the scales and their positions are the same.

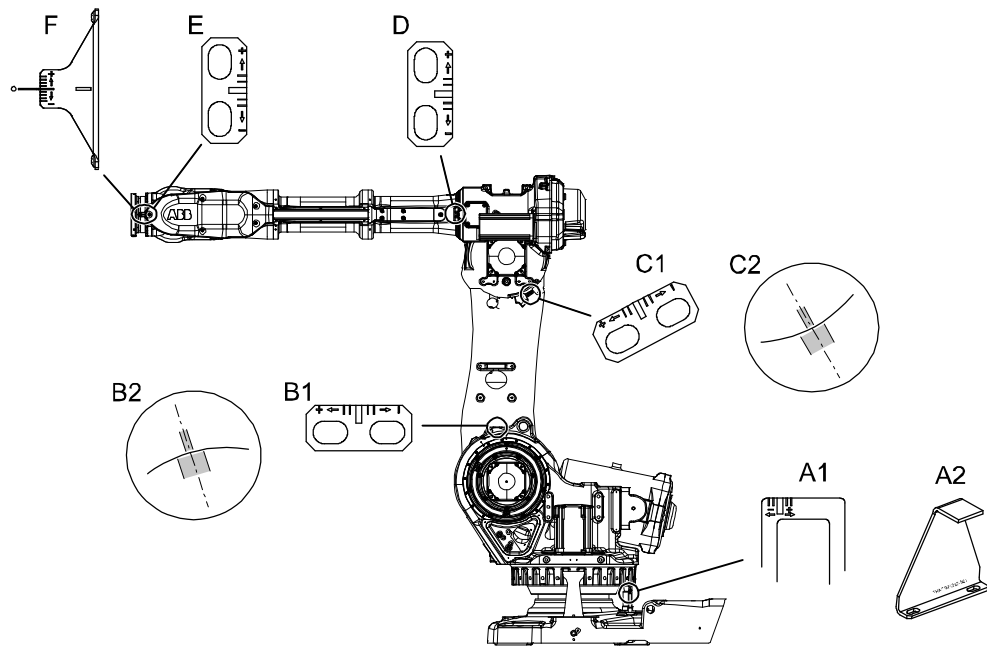

xx0200000176

A1	Synchronization mark, axis 1 (early design)
A2	Synchronization mark, axis 1 (later design)
B1	Synchronization mark, axis 2 (early design)
B2	Synchronization mark, axis 2 (later design)
C1	Synchronization mark, axis 3 (early design)
C2	Synchronization mark, axis 3 (later design)
D	Synchronization mark, axis 4
E	Synchronization mark, axis 5
F	Synchronization mark, axis 6

Synchronization marks at axes 2 and 3

The synchronization marks at axes 2, 3 and 6, shown in the figure above, consist of two single marks that should be positioned opposite to one another when the robot is standing in its synchronization position. One of the marks is more narrow than the other and should be positioned within the limits of the wider mark.

5.2.2 Calibration movement directions for all axes

Overview

When calibrating, the axis must consistently be run towards the calibration position in the same direction in order to avoid position errors caused by backlash in gears and so on. Positive directions are shown in the graphic below.

Calibration service routines will handle the calibration movements automatically and these might be different from the positive directions shown below.

Manual movement directions, 6 axes

Note! The graphic shows an IRB 7600. The positive direction is the same for all 6-axis robots, except the positive direction of axis 3 for IRB 6400R, which is in the opposite direction!

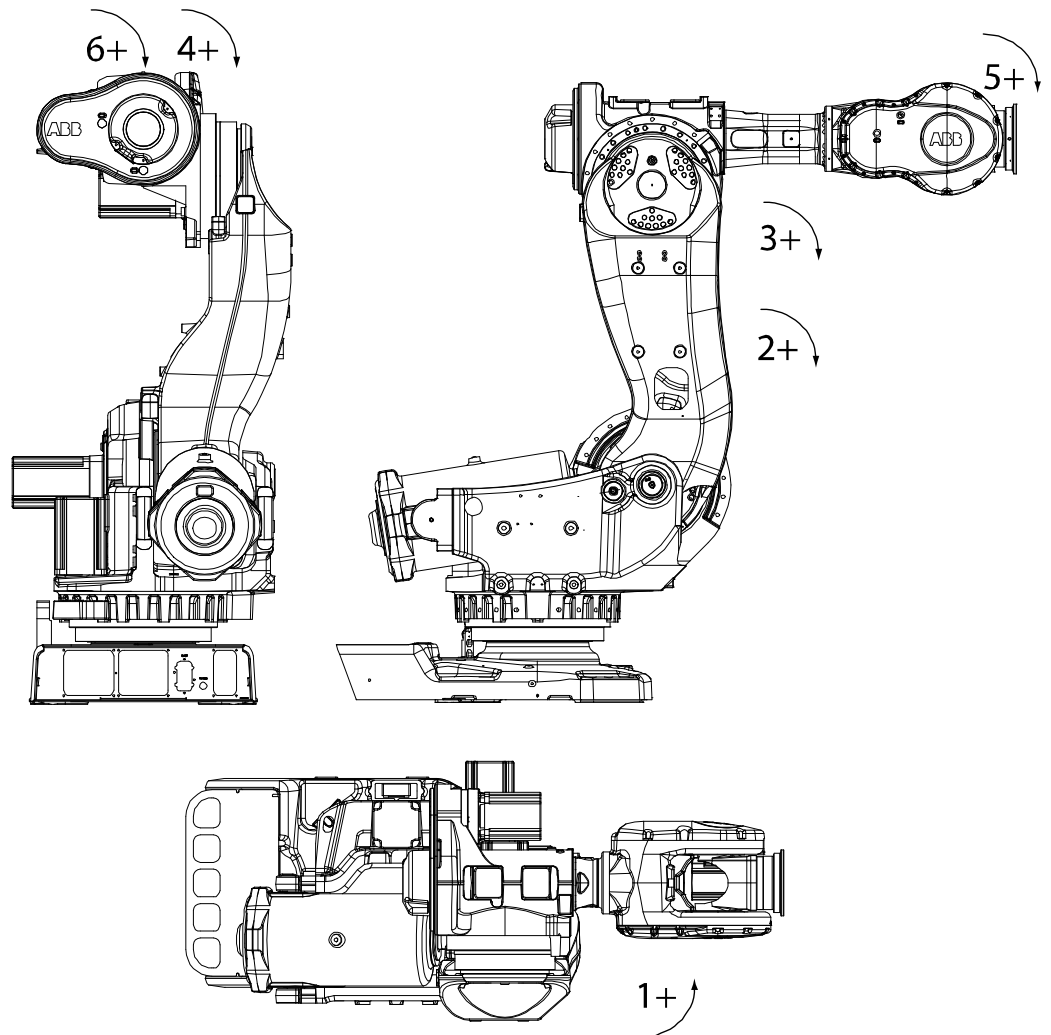

xx020000089

5 Calibration

5.3.1 Updating revolution counters on IRC5 robots

5.3 Updating revolution counters

5.3.1 Updating revolution counters on IRC5 robots

Introduction

This section describes how to do a rough calibration of each manipulator axis by updating the revolution counter for each axis, using the FlexPendant.

Step 1 - Manually running the manipulator to the synchronization position

Use this procedure to manually run the manipulator to the synchronization position.

	Action	Note
1	Select axis-by-axis motion mode.	
2	Jog the manipulator to align the synchronization marks.	See Synchronization marks and synchronization position for axes on page 364 .
3	When all axes are positioned, update the revolution counter.	Step 2 - Updating the revolution counter with the FlexPendant on page 367 .

Correct calibration position of axis 4 and 6

When jogging the manipulator to synchronization position, it is extremely important to make sure that axes 4 and 6 of the following mentioned manipulators are positioned correctly. The axes can be calibrated at the wrong turn, resulting in an incorrect manipulator calibration.

Make sure the axes are positioned according to the correct calibration values, not only according to the synchronization marks. The correct values are found on a label, located either on the lower arm, underneath the flange plate on the base or on the frame.

At delivery the manipulator is in the correct position. Do NOT rotate axis 4 or 6 at power up before the revolution counters are updated.

If one of the following mentioned axes are rotated one or more turns from its calibration position before updating the revolution counter, the correct calibration position will be lost due to non-integer gear ratio. This affects the following manipulators:

Manipulator variant	Axis 4	Axis 6
IRB 6650S	Yes	Yes

If the synchronization marks seem to be wrong (even if the motor calibration data is correct), try to rotate the axis one turn, update the revolution counter and check the synchronization marks again (try both directions, if needed).

Continues on next page

Step 2 - Updating the revolution counter with the FlexPendant

Use this procedure to update the revolution counter with the FlexPendant (IRC5).

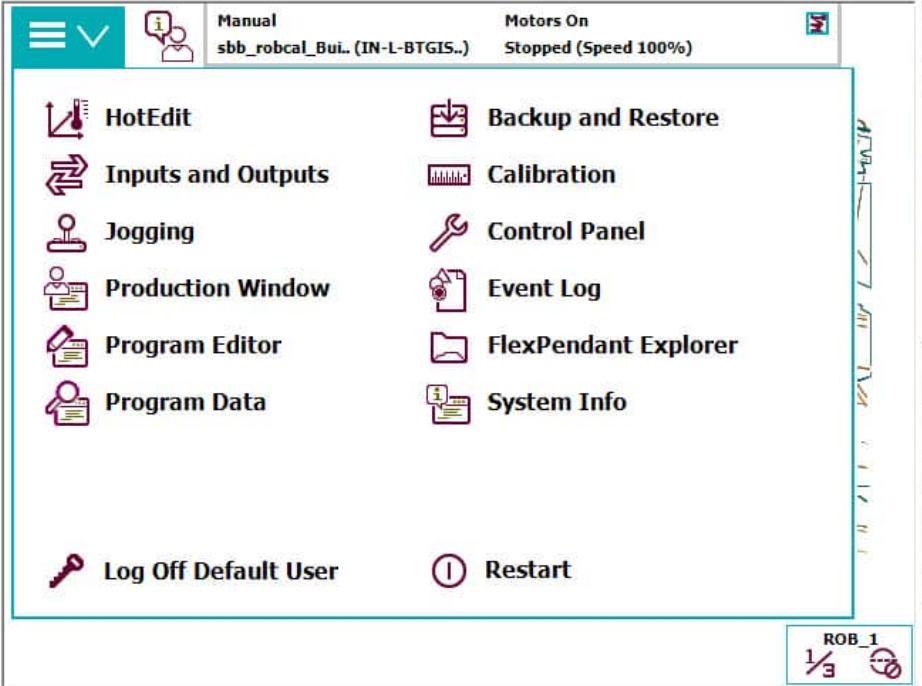
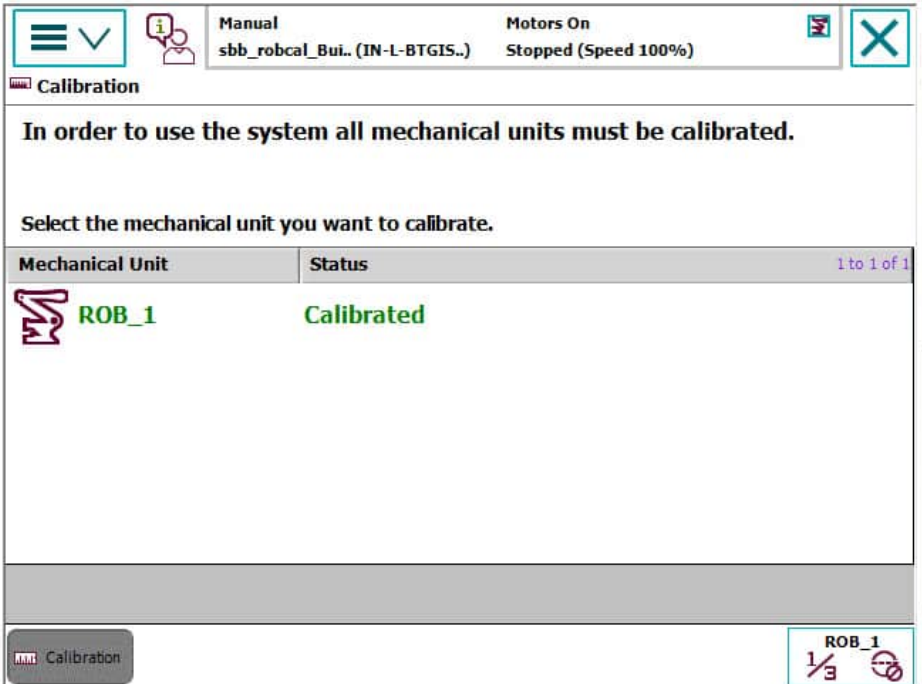
Action	
1	<p>On the ABB menu, tap Calibration.</p>  <p>xx150000942</p>
2	<p>All mechanical units connected to the system are shown with their calibration status. Tap the mechanical unit in question.</p>  <p>xx150000943</p>

Continues on next page

5 Calibration

5.3.1 Updating revolution counters on IRC5 robots

Continued

Action

3 This step is valid for RobotWare 6.02 and later.
 Calibration method used at factory for each axis is shown, as well as calibration method used during last field calibration.
 Tap **Manual Method (Advanced)**.

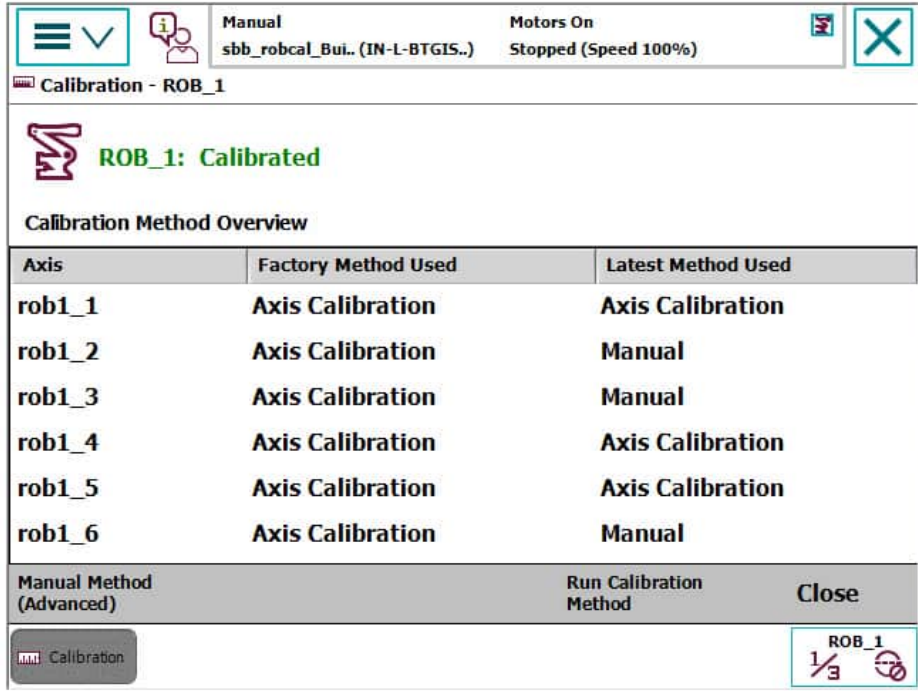

xx1500000944

4 A screen is displayed, tap **Rev. Counters**.

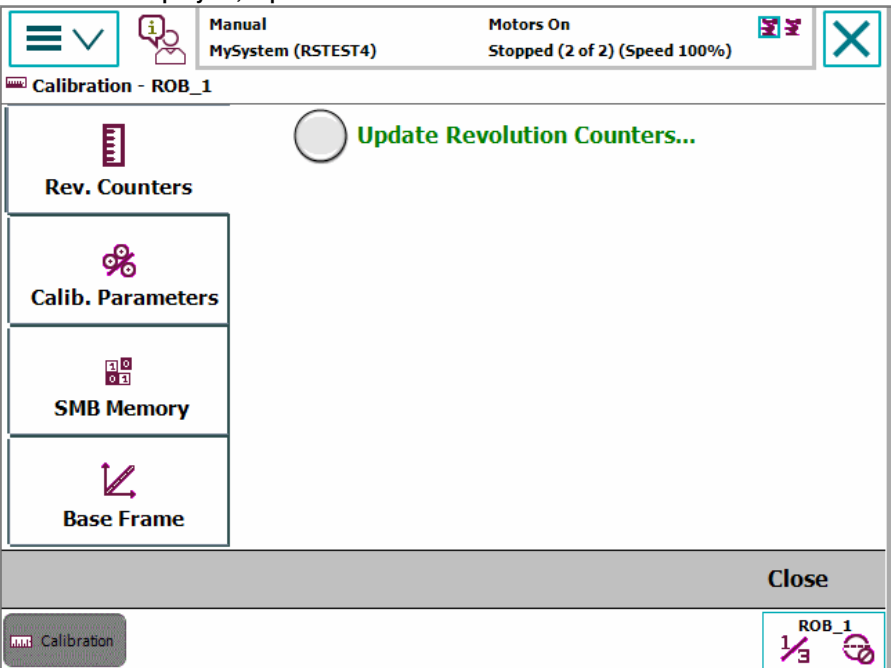

en0400000771

Axis	Factory Method Used	Latest Method Used
rob1_1	Axis Calibration	Axis Calibration
rob1_2	Axis Calibration	Manual
rob1_3	Axis Calibration	Manual
rob1_4	Axis Calibration	Axis Calibration
rob1_5	Axis Calibration	Axis Calibration
rob1_6	Axis Calibration	Manual

Continues on next page

	Action
5	<p>Tap Update Revolution Counters...</p> <p>A dialog box is displayed, warning that updating the revolution counters may change programmed robot positions:</p> <ul style="list-style-type: none"> • Tap Yes to update the revolution counters. • Tap No to cancel updating the revolution counters. <p>Tapping Yes displays the axis selection window.</p>
6	<p>Select the axis to have its revolution counter updated by:</p> <ul style="list-style-type: none"> • Ticking in the box to the left • Tapping Select all to update all axes. <p>Then tap Update.</p>
7	<p>A dialog box is displayed, warning that the updating operation cannot be undone:</p> <ul style="list-style-type: none"> • Tap Update to proceed with updating the revolution counters. • Tap Cancel to cancel updating the revolution counters. <p>Tapping Update updates the selected revolution counters and removes the tick from the list of axes.</p>
8	<p> CAUTION</p> <p>If a revolution counter is incorrectly updated, it will cause incorrect manipulator positioning, which in turn may cause damage or injury!</p> <p>Check the synchronization position very carefully after each update. See Checking the synchronization position on page 387.</p>

5 Calibration

5.3.2 Updating revolution counters on OmniCore robots

5.3.2 Updating revolution counters on OmniCore robots

Introduction

This section describes how to do a rough calibration of each manipulator axis by updating the revolution counter for each axis, using the FlexPendant.



Step 1 - Manually running the manipulator to the synchronization position

Use this procedure to manually run the manipulator to the synchronization position.

	Action	Note
1	Select axis-by-axis motion mode.	
2	Jog the manipulator to align the synchronization marks.	See Synchronization marks and synchronization position for axes on page 364 .
3	When all axes are positioned, update the revolution counter.	Step 2 - Updating the revolution counter with the FlexPendant on page 370 .

Step 2 - Updating the revolution counter with the FlexPendant

Use this procedure to update the revolution counter with the FlexPendant (OmniCore).

	Action
1	On the start screen, tap Calibrate .
2	Select Calibration from the menu. The Mechanical Units page displays a list of available mechanical units.  Note This step is required only if you are not already in the Mechanical Unit page when you open Calibrate .  Note The Mechanical Unit page is displayed only if there are more than one mechanical unit available. Otherwise, the calibration summary page for the available mechanical unit is displayed.
3	Select the mechanical unit for which revolution counter need to be updated.
4	The calibration summary page for the selected mechanical unit is displayed. Calibration method used at factory for each axis is shown, as well as calibration method used during last field calibration.
5	Tap Calibration Methods on the right pane. The calibration options are displayed.
6	Tap Revolution Counters .
7	In the Selection column select the axes for which revolution counters need to be updated.
8	Tap Update . A dialog box is displayed, warning that the updating operation cannot be undone: <ul style="list-style-type: none">• Tap Update to proceed with updating the revolution counters.• Tap Cancel to cancel updating the revolution counters. Tapping Update and a confirmation window is displayed.

Continues on next page

Action	
9	Tap OK. The revolution counter for the selected axes is updated.
10	 CAUTION If a revolution counter is incorrectly updated, it will cause incorrect manipulator positioning, which in turn may cause damage or injury! Check the synchronization position very carefully after each update. See Checking the synchronization position on page 387 .

5 Calibration

5.4.1 Description of Axis Calibration

5.4 Calibrating with Axis Calibration method

5.4.1 Description of Axis Calibration

Instructions for Axis Calibration procedure given on the FlexPendant

The actual instructions of how to perform the calibration procedure and what to do at each step is given on the FlexPendant. You will be guided through the calibration procedure, step by step.

This manual contains a brief description of the method, additional information to the information given on the FlexPendant, article number for the tools and images of where to fit the calibration tools on the robot.

Overview of the Axis Calibration procedure

The Axis Calibration procedure applies to all axes, and is performed on one axis at the time. The robot axes are both manually and automatically moved into position, as instructed on the FlexPendant.

A fixed calibration pin/bushing is installed on each robot axis at delivery.

The Axis Calibration procedure described roughly:

- 1 A removable calibration tool is inserted by the operator into a calibration bushing on the axis chosen for calibration, according to instructions on the FlexPendant.



WARNING

Calibrating the robot with Axis Calibration requires special calibration tools from ABB. Using other pins in the calibration bushings may cause severe damage to the robot and/or personnel.



WARNING

The calibration tool must be fully inserted into the calibration bushing, until the steel spring ring snaps into place.

- 2 During the calibration procedure, RobotWare moves the robot axis chosen for calibration so that the calibration tools get into contact. RobotWare records values of the axis position and repeats the coming-in-contact procedure several times to get an exact value of the axis position.



WARNING

Risk of pinching! The contact force for large robots can be up to 150 kg. Keep a safe distance to the robot.

- 3 The axis position is stored in RobotWare with an active choice from the operator.

Continues on next page

Routines in the calibration procedure

The following routines are available in the Axis Calibration procedure, given at the beginning of the procedure on the FlexPendant.

Fine calibration routine

Choose this routine to calibrate the robot when there are no tools, process cabling or equipment fitted to the robot.

Reference calibration routine

Choose this routine to create reference values and to calibrate the robot when the robot is dressed with tools, process cabling or other equipment.



Note

When calibrating the robot with the reference calibration routine, the robot must be dressed with the same tools, process cabling and any other equipment as when the reference values were created.



Note

When using reference calibration with some tools, typically large or flexible tools, oscillations in the robot can cause issues leading to failure of the calibration.

If calibrating the robot with reference calibration there must be reference values created before repair is made to the robot, if values are not already available. Creating new values requires possibility to move the robot. The reference values contain positions of all axes, torque of axes and technical data about the tool installed. A benefit with reference calibration is that the current state of the robot is stored and not the state when the robot left the ABB factory. The reference value will be named according to tool name, date etc.

Follow the instructions given in the reference calibration routine on the FlexPendant to create reference values.

When reference calibration is performed, the robot is restored to the status given by the reference values.

Update revolution counters

Choose this routine to make a rough calibration of each manipulator axis by updating the revolution counter for each axis, using the FlexPendant.

Validation

In the mentioned routines, it is also possible to validate the calibration data.

Position of robot axes

The robot axes should be positioned close to 0 degrees before commencing the calibration program. The axis chosen for calibration is then automatically run by the calibration program to its exact calibration position during the calibration procedure.

It is possible to position some of the other axes in positions different from 0 degrees. Information about which axes are allowed to be jogged is given on the FlexPendant.

Continues on next page

5 Calibration

5.4.1 Description of Axis Calibration

Continued

These axes are marked with **Unrestricted** in the FlexPendant window. Also the following table shows the dependencies between the axes.

Requirements for axis positioning during calibration

Required position of axis	Axis to calibrate					
	Axis 1	Axis 2	Axis 3	Axis 4	Axis 5	Axis 6
Axis 1	-	*	*	*	*	*
Axis 2	0	-	0	*	*	*
Axis 3	0	0	-	*	*	*
Axis 4	*	*	*	-	*	*
Axis 5	*	*	*	*	-	*
Axis 6	*	*	*	*	*	-

-	Axis to be calibrated
*	Unrestricted. Axis is allowed to be jogged to other position than 0 degrees.
0	Axis must be put in position 0 degrees.

System containing SafeMove

SafeMove will lose its synchronization to the controller if a new calibration is done. New calibration values have to be downloaded to SafeMove, and a new SafeMove calibration has to be done. Make sure that the user rights admit to change the safety settings and to synchronize SafeMove.

For robots with EPS, the same applies as for SafeMove.

5.4.2 Calibration tools for Axis Calibration

Calibration tool set

The calibration tools used for Axis Calibration are designed to meet requirements for calibration performance, durability and safety in case of accidental damage.

The calibration tool will eventually break from fatigue after longer period of use and then needs to be replaced. There is no risk for bad calibrations as long as the calibration tool is in one piece.



WARNING

Calibrating the robot with Axis Calibration requires special calibration tools from ABB. Using other pins in the calibration bushings may cause severe damage to the robot and/or personnel.

Equipment, etc.	Article number	Note
Calibration tool box, Axis Calibration	3HAC055412-001	Delivered as a set of calibration tools. Required if Axis Calibration is the valid calibration method for the robot.

Examining the calibration tool

Check prior to usage

Before using the calibration tool, make sure that the tube insert, the plastic protection and the steel spring ring are present.



WARNING

If any part is missing or damaged, the tool must be replaced immediately.

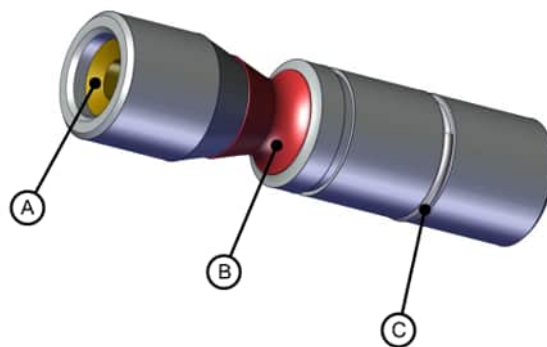

xx1500001914

A	Tube insert
B	Plastic protection
C	Steel spring ring

Continues on next page

5 Calibration

5.4.2 Calibration tools for Axis Calibration

Continued

Periodic check of the calibration tool

If including the calibration tool in a local periodic check system, the following measures should be checked.

- Outer diameter within $\varnothing 12g4$ mm, $\varnothing 8g4$ mm or $\varnothing 6g5$ mm (depending on calibration tool size).
- Straightness within 0.005 mm.

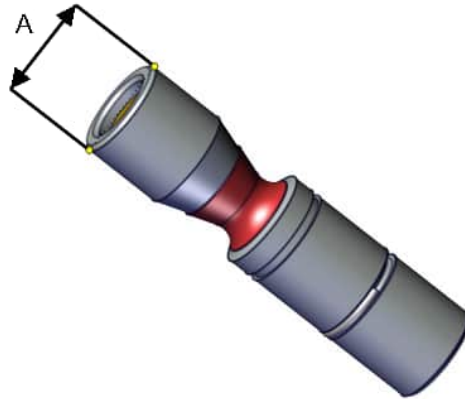

xx150000951

A	Outer diameter
---	----------------

Identifying the calibrating tools

It is possible to make the calibration tool identifiable with, for example, an RFID chip. The procedure of how to install an RFID chip is described below.



Note

The tool identifier is NOT delivered from ABB, it is a customized solution.

	Action	Note
1	<p>It is possible to use any RFID solution, with the correct dimensions. ABB has verified function on some suppliers fulfilling the requirements of NFC compatible devices (13.56 Mhz) according to ISO 14443 or ISO 15693.</p>  <p>Note</p> <p>The maximum dimensions on the RFID chip must not exceed $\varnothing 7.9$ mm x 8.0 mm, $\varnothing 5.9$ mm x 8.0 mm or $\varnothing 3.9$ mm x 8.0 mm (depending on calibration tool size).</p>	
2	<p>There is a cavity on one end of the calibration tool in which the RFID chip can be installed.</p> <p>Install the RFID chip according to supplier instructions.</p> <p>Install the chip in flush with the tool end.</p>	

5.4.3 Installation locations for the calibration tools

Location of fixed calibration items

This section shows how the robot is equipped with items for installation of calibration tools for Axis Calibration (fixed calibration pins and/or bushings). Installed calibration tools are not shown.

A fixed calibration pin and a bushing for the movable calibration tool are located on each axis as follows.

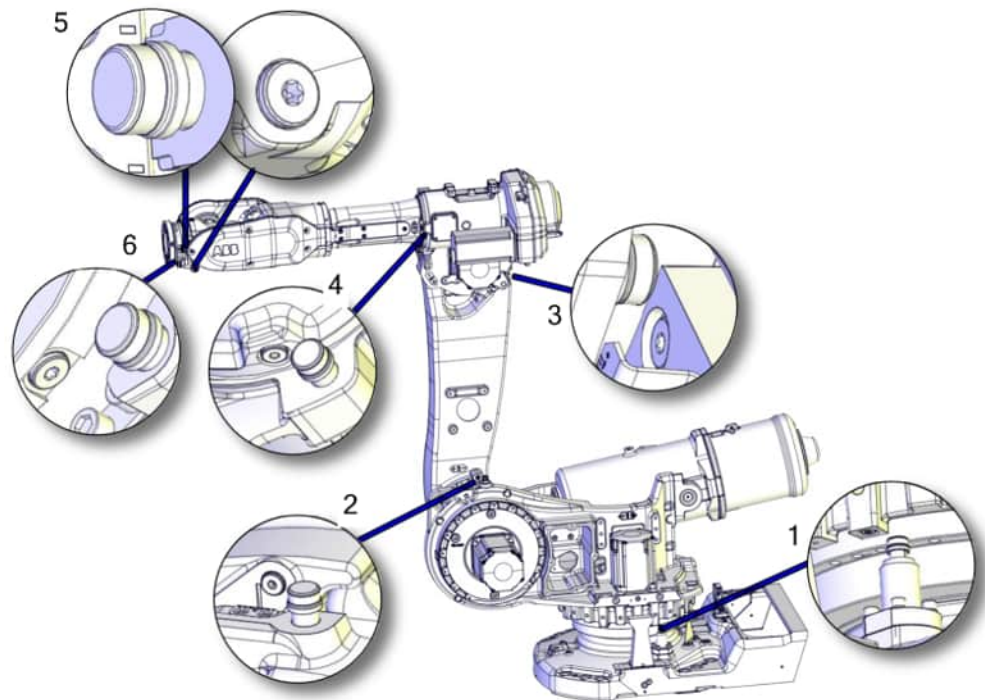

xx150000912

The fixed calibration pin for axis 1 is installed on a removable tower. The tower will need to be removed if electronic position switches are fitted to the robot. Keep the tower in a safe location for future recalibration needs and mark it with robot serial number to ensure that the correct one is refitted.

Spare parts

When calibration is not being performed, a protective cover and an o-ring should always be installed on the fixed calibration pin as well as a protective plug, included a sealing, in the bushing. Replace damaged parts with new.

Spare part	Article number	Note
Protection cover and plug set	3HAC056806-001	Contains replacement calibration pin covers and protective plugs for the bushing.

5 Calibration

5.4.4 Axis Calibration - Running the calibration procedure

5.4.4 Axis Calibration - Running the calibration procedure

Required tools

The calibration tools used for Axis Calibration are designed to meet requirements for calibration performance, durability and safety in case of accidental damage.



WARNING

Calibrating the robot with Axis Calibration requires special calibration tools from ABB. Using other pins in the calibration holes may cause severe damage to the robot and/or personnel.

Equipment, etc.	Article number	Note
Calibration tool box, Axis Calibration	3HAC055412-001	Delivered as a set of calibration tools. Required if Axis Calibration is the valid calibration method for the robot.

Required consumables

Consumable	Article number	Note
Clean cloth	-	

Spare parts

Spare part	Article number	Note
Protection cover and plug set	3HAC056806-001	Contains replacement calibration pin covers and protective plugs for the bushing.

Overview of the calibration procedure on the FlexPendant

The actual instructions of how to perform the calibration procedure and what to do at each step is given on the FlexPendant. You will be guided through the calibration procedure, step by step.

Use the following list to learn about the calibration procedure before running the RobotWare program on the FlexPendant. It gives you a brief overview of the calibration procedure.

After the calibration method has been started on the FlexPendant, the following sequence will be run.

- 1 Choose calibration routine. The routines are described in [Routines in the calibration procedure on page 373](#).
- 2 Choose which axis/axes to calibrate.
- 3 The robot moves to synchronization position.
- 4 Validate the synchronization marks.
- 5 The robot moves to preparation position.
- 6 Remove the protective cover from the fixed pin and the protection plug from the bushing, if any, and install the calibration tool.

Continues on next page

5.4.4 Axis Calibration - Running the calibration procedure



Continued

- 7 The robot performs a measurement sequence by rotating the axis back and forth.
- 8 Remove the calibration tool and reinstall the protective cover on the fixed pin and the protection plug in the bushing, if any.
- 9 The robot moves to verify that the calibration tool is removed.
- 10 Choose whether to save the calibration data or not.

Calibration of the robot is not finished until the calibration data is saved, as last step of the calibration procedure.

Preparation prior to calibration

The calibration procedure is described in the FlexPendant while conducting it.

	Action	Note
1	 DANGER While conducting the calibration, the robot needs to be connected to power. Make sure that the robot's working area is empty, as the robot can make unpredictable movements.	
2	Wipe the calibration tool clean.  Note The calibration method is exact. Dust, dirt or color flakes will affect the calibration value.	Use a clean cloth.
3	Check if the standard calibration data for axes 4 or 5 are updated with wrist optimization. This is shown in the calibration overview/summary window on the FlexPendant.	If the data is optimized, the calibration routine Wrist Optimization must be re-run after standard calibration. See Calibrating with Wrist Optimization method on page 384 .

Starting the calibration procedure

Use this procedure to start the Axis Calibration routine on the FlexPendant.

	Action	Note
1	Tap the calibration icon and enter the calibration main page.	
2	All mechanical units connected to the system are shown with their calibration status. Tap the mechanical unit in question.  Note For RobotWare 7, the mechanical unit page is displayed only if there is more than one mechanical unit available.	
3	The calibration method used at ABB factory for each axis is shown, as well as calibration method used for the robot during last field calibration.	The FlexPendant will give all information needed to proceed with Axis Calibration.

Continues on next page

5 Calibration

5.4.4 Axis Calibration - Running the calibration procedure

Continued

	Action	Note
4	Valid for RobotWare 6 Tap Call Calibration Method . The software will automatically call for the procedure for the valid calibration method. If not, tap Call Routine and then tap Axis calibration .	
5	Valid for RobotWare 7 Tap Calibration Methods on the right pane and then tap Calibration . The software will automatically call for the procedure for the valid calibration method.	
6	Follow the instructions given on the FlexPendant.	A brief overview of the sequence that will be run on the FlexPendant is given in Overview of the calibration procedure on the FlexPendant on page 378 .

Restarting an interrupted calibration procedure

If the Axis Calibration procedure is interrupted before the calibration is finished, the RobotWare program needs to be started again. Use this procedure to take required action.

Situation	Action
The three-position enabling device on the FlexPendant has been released during robot movement.	Press and hold the three-position enabling device and press Play .
The RobotWare program is terminated with PP to Main .	Remove the calibration tool, if it is installed, and restart the calibration procedure from the beginning. See Starting the calibration procedure . If the calibration tool is in contact the robot axis needs to be jogged in order to release the calibration tool. Jogging the axis in wrong direction will cause the calibration tool to break. Directions of axis movement is shown in Calibration movement directions for all axes on page 365

Axis Calibration with SafeMove option

To be able to run Axis Calibration, SafeMove needs to be unsynchronized. The Axis Calibration routine recognizes if the robot is equipped with SafeMove and will force SafeMove to unsynchronize automatically.

However, SafeMove may generate other warning messages anytime during the Axis Calibration routine. When a warning message is displayed, tap **Acknowledge** to confirm the unsynchronized state and continue Axis Calibration procedure.



CAUTION

SafeMove must be synchronized after the calibration is completed.

Continues on next page

5.4.4 Axis Calibration - Running the calibration procedure
Continued

After calibration

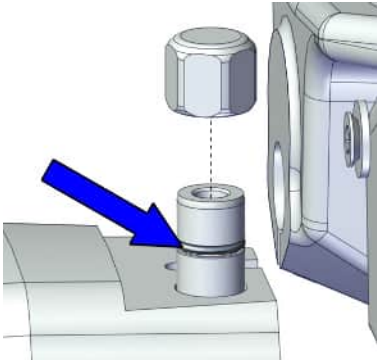
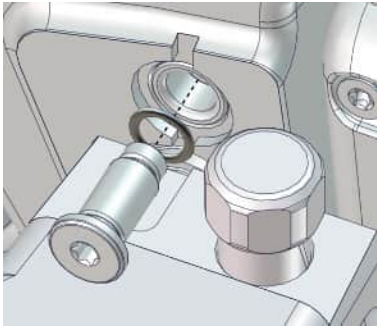
	Action	Note
1	Check the o-ring on the fixed calibration pin. Replace if damaged or missing.	 <p data-bbox="1059 725 1166 745">xx1600002102</p> <p data-bbox="1059 763 1394 815">Protection cover and plug set: 3HAC056806-001.</p>
2	Reinstall the protective cover on the fixed calibration pin on each axis, directly after the axis has been calibrated. Replace the cover with new spare part, if missing or damaged.	
3	Reinstall the protective plug and sealing in the bushing on each axis, directly after the axis has been calibrated. Ensure that the sealing is not damaged. Replace the plug and the sealing with new spare part, if missing or damaged.	 <p data-bbox="1059 1164 1166 1184">xx1500000952</p> <p data-bbox="1059 1202 1394 1254">Protection cover and plug set: 3HAC056806-001.</p>
4	If the standard calibration data for axes 4, 5 or 6 should be updated with wrist optimization, run the calibration routine Wrist Optimization .	See Calibrating with Wrist Optimization method on page 384 .

5.4.5 Reference calibration

Brief introduction to Reference Calibration

Reference calibration is a faster method compared to Fine calibration, as it refers to a previously made calibration.

- 1 Create a backup of the current robot system.
- 2 Check that the active calibration offset values corresponds to the values on the silver label (on the lower arm or the base).
- 3 Jog the manipulator so that all axes are in zero position (ex use `MoveAbsJ` instruction). Check that all axis scales are aligned with calibration marks.
- 4 If the scales differ from calibration marks it might depend on wrong turns of the revolution counters. Make a marker line on the corresponding axis to be able to validate the result of the calibration. If more than one motor revolutions are wrong, the calibration will fail.
- 5 Use a verification position. This is especially recommended if all axes were not aligned with the synchronization marks (step 3). Reuse an existing position that is suitable and accurate so it can be used to validate the repair. Use a position where a deviation in axis calibration gives a big deviation in positioning. Note! Check the position after each repair in one axis.
- 6 Use Reference calibration to save reference values for all axes that is to be replaced. Make sure that the values are saved in RobotStudio or FTP program. The files are located in "Active system folder name/HOME/RefCalibFiles".
- 7 Perform the repair.
- 8 Make sure that the tooling and process equipment are the same as when creating the reference. Use Reference calibration to update the system with new calibration offset value for the repaired axis.
- 9 Check the position against the verification position (step 5).
- 10 Proceed with the repair of the next axis, if necessary, and repeat (step 8-9) for every axis.
- 11 (For system containing SafeMove or EPS) Download new calibration values to SafeMove. Use Visual SafeMove in RobotStudio.(For system containing SafeMove) Download new calibration values to SafeMove. Use Visual SafeMove in RobotStudio.
- 12 (For system containing SafeMove or EPS) Synchronize SafeMove to activate SafeMove.(For system containing SafeMove) Synchronize SafeMove to activate SafeMove.
- 13 Perform test run.
- 14 Update the label for resolver values with new calibration values.

Manual tuning of calibration offset

Manual tuning of calibration offset is normally not needed, but can be useful in some situations. The requirement to do manual tuning is that there is a known accurate position, that worked accurately before the repair (step 5, see [Brief introduction to Reference Calibration on page 382](#)).

Continues on next page

Example "Adjust axis 4":

- 1 Create a backup.
- 2 Run the manipulator to the verification position. (The manipulator position is now deviating from the verification position.)
- 3 Read and note current axis 4 value in degrees (example: 96.3 degrees).
- 4 Manually jog, only axis 4, so that the manipulator is correctly positioned to the verification position.
- 5 Read and note current axis 4 value in degrees (example: 94.2 degrees).
- 6 Move the manipulator to its calibration position.
- 7 Calculate the angle difference (ie $96.3 - 94.2 = 2.1$ degrees).
- 8 Manually jog axis 4 the calculated angle difference (-2.1). NOTE! The direction +/- shall be the same direction as the direction used when axis 4 was manually jogged to coincide with the verification process. In the example -2.1 degrees.
- 9 Make a new manual fine calibration of axis 4 with axis in -2.1 degrees position.
- 10 Check again against the verification position.
- 11 Repeat the manual tuning if needed.
- 12 Create a new reference if the intention is to use the reference in the future.

5 Calibration

5.5 Calibrating with Wrist Optimization method

5.5 Calibrating with Wrist Optimization method

When to run Wrist Optimization

Wrist Optimization routine is run to improve TCP reorientation performance.

Calibrating the robot with standard calibration method overwrites the optimized positions of axes 4, 5. Re-run the Wrist Optimization routine after standard calibration to re-achieve the optimized positions of the wrist axes.

Overview of the calibration procedure on the FlexPendant

The actual instructions of how to perform the calibration procedure and what to do at each step is given on the FlexPendant. You will be guided through the calibration procedure, step by step.

Use the following list to learn about the calibration procedure before running the RobotWare program on the FlexPendant. It gives you a brief overview of the calibration procedure sequence.

After the calibration method has been called for on the FlexPendant, the following sequence will be run.

- 1 Choose calibration routine Wrist Optimization.
- 2 Modify targets for 4-point tool frame definition, in Wrist Optimization routine.



Tip

Select positions with large reorientations around the TCP. For best results, make sure that axis 4 and 5 have large movements.

- a Jog the robot to an appropriate position, A, for the first approach point.
Use small increments to accurately position the tool tip as close to the reference point as possible.
- b Tap **Modify Position** to define the point.
- c Repeat for each approach point to be defined, positions B, C, and D.
Jog away from the fixed world point to achieve the best result. Just changing the tool orientation will not give as good a result.

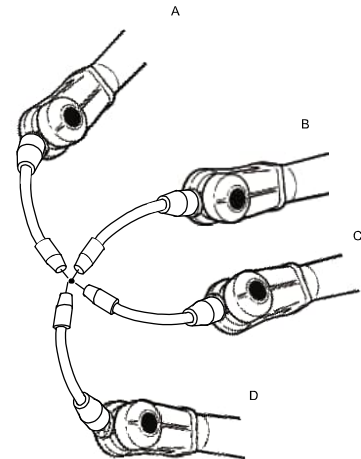

en0400000906

- 3 Improved calibration data to the wrist axes is identified and presented.
- 4 Optimized positions for the wrist axes are presented.

Continues on next page

- 5 The robot moves to the optimized positions for the wrist axes and automatically overwrites previous calibration data.



WARNING

Robot moves automatically when pressing **Calibrate**.

- 6 Wrist optimization is finished.
- 7 Redefine / verify TCP for all tools.

5 Calibration

5.6 Verifying the calibration

5.6 Verifying the calibration

Introduction

Always verify the results after calibrating *any* robot axis to verify that all calibration positions are correct.

Verifying the calibration

Use this procedure to verify the calibration result.

	Action	Note
1	Run the calibration home position program twice. Do not change the position of the robot axes after running the program!	See Checking the synchronization position on page 387 .
2	Adjust the <i>synchronization marks</i> when the calibration is done, if necessary.	This is detailed in section Synchronization marks and synchronization position for axes on page 364 .
3	Write down the values on a new label and stick it on top of the calibration label. The label is located on the lower arm.	

5.7 Checking the synchronization position

Introduction

Check the synchronization position of the robot before beginning any programming of the robot system. This may be done:

- Using a `MoveAbsJ` instruction with argument zero on all axes.
- Using the **Jogging** window on the FlexPendant. Using the **Jog** window on the FlexPendant.

Using a `MoveAbsJ` instruction

Use this procedure to create a program that runs all the robot axes to their synchronization position.

	Action	Note
1	On ABB menu tap Program editor .	
2	Create a new program.	
3	Use MoveAbsJ in the Motion&Proc menu.	
4	Create the following program: <pre>MoveAbsJ [[0,0,0,0,0,0], [9E9,9E9,9E9,9E9,9E9,9E9]] \NoEOffs, v1000, fine, tool0</pre>	
5	Run the program in manual mode.	
6	Check that the synchronization marks for the axes align correctly. If they do not, update the revolution counters.	See Synchronization marks and synchronization position for axes on page 364 and Updating revolution counters on page 366 .

Using the jogging window

Use this procedure to jog the robot to the synchronization position of all axes.

	Action	Note
1	On the ABB menu, tap Jogging .	
2	Tap Motion mode to select group of axes to jog.	
3	Tap to select the axis to jog, axis 1, 2, or 3.	
4	Manually run the robots axes to a position where the axis position value read on the FlexPendant, is equal to zero.	
5	Check that the synchronization marks for the axes align correctly. If they do not, update the revolution counters.	See Synchronization marks and synchronization position for axes on page 364 and Updating revolution counters on page 366 .

Continues on next page

5 Calibration

5.7 Checking the synchronization position

Continued

Using a MoveAbsJ instruction

Use this procedure to create a program that runs all the robot axes to their synchronization position.

	Action	Note
1	Tap Code.	
2	Create a new program.	
3	Use MoveAbsJ in the Add Instruction menu.	
4	Create the following program: <pre>MoveAbsJ [[0,0,0,0,0,0], [9E9,9E9,9E9,9E9,9E9,9E9]] \NoEOfs, v1000, fine, tool0</pre>	
5	Run the program in manual mode.	
6	Check that the synchronization marks for the axes align correctly. If they do not, update the revolution counters.	See Synchronization marks and synchronization position for axes on page 364 and Updating revolution counters on page 366 .

Using the jogging window

Use this procedure to jog the robot to the synchronization position of all axes.

	Action	Note
1	Tap Jog.	
2	From the Mechanical unit list select a mechanical unit.	
3	From the Motion mode section, select an axis-set that need to be jogged. For example, to jog axis 2, select the axis set Axis 1-3 .	
4	Follow the screen instruction on joystick movements to understand the direction of the axis that you want to move and move the joystick.	
5	Manually run the robots axes to a position where the axis position value read on the FlexPendant, is equal to zero.	
6	Check that the synchronization marks for the axes align correctly. If they do not, update the revolution counters.	See Synchronization marks and synchronization position for axes on page 364 and Updating revolution counters on page 366 .

6 Decommissioning

6.1 Introduction to decommissioning

Introduction

This section contains information to consider when taking a product, robot or controller, out of operation.

It deals with how to handle potentially dangerous components and potentially hazardous materials.



Note

The decommissioning process shall be preceded by a risk assessment.

Disposal of materials used in the robot

All used grease/oils and dead batteries **must** be disposed of in accordance with the current legislation of the country in which the robot and the control unit are installed.

If the robot or the control unit is partially or completely disposed of, the various parts **must** be grouped together according to their nature (which is all iron together and all plastic together), and disposed of accordingly. These parts **must** also be disposed of in accordance with the current legislation of the country in which the robot and control unit are installed.

See also [Environmental information on page 390](#).

Transportation

Prepare the robot or parts before transport, this to avoid hazards.

6 Decommissioning

6.2 Environmental information

6.2 Environmental information

Introduction

ABB robots contain components in different materials. During decommissioning, all materials should be dismantled, recycled, or reused responsibly, according to the relevant laws and industrial standards. Robots or parts that can be reused or upcycled helps to reduce the usage of natural resources.

Symbol

The following symbol indicates that the product must not be disposed of as common garbage. Handle each product according to local regulations for the respective content (see table below).

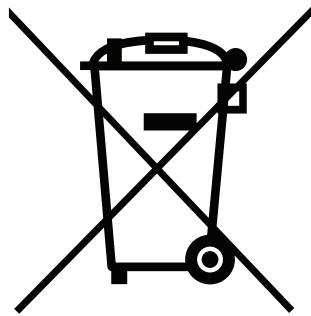

xx1800000058

Materials used in the product

The table specifies some of the materials in the product and their respective use throughout the product.

Dispose components properly according to local regulations to prevent health or environmental hazards.

Material	Example application
Aluminium	Covers, synchronization brackets
Batteries, Lithium	Serial measurement board
Cast iron/nodular iron	Base, lower arm, upper arm
Copper	Cables, motors
Neodymium	Brakes, motors
Nickel	Turning disc (foundry)
Oil, grease	Gearboxes
Plastic/rubber	Cables, connectors, drive belts, and so on.
Steel	Gears, screws, base frame, and so on.

Continues on next page

Oil and grease

Where possible, arrange for oil and grease to be recycled. Dispose of via an authorized person/contractor in accordance with local regulations. Do not dispose of oil and grease near lakes, ponds, ditches, down drains, or onto soil. Incineration must be carried out under controlled conditions in accordance with local regulations.

Also note that:

- Spills can form a film on water surfaces causing damage to organisms. Oxygen transfer could also be impaired.
- Spillage can penetrate the soil causing ground water contamination.

6 Decommissioning

6.3 Scrapping of robot

6.3 Scrapping of robot



Note

The decommissioning process shall be preceded by a risk assessment.

Important when scrapping the robot



DANGER

The risk assessment should consider hazards arising in the decommissioning, such as, but not limited to:

- Always remove all batteries. If a battery is exposed to heat, for example from a blow torch, it will explode.
- Always remove all oil/grease in gearboxes. If exposed to heat, for example from a blow torch, the oil/grease will catch fire.
- When motors are removed from the robot, the robot will collapse if it is not properly supported before the motor is removed.
- A used robot does not have the same performance as on delivery. Springs, brakes, bearings, and other parts might be worn or broken.

6.4 Decommissioning of balancing device

General

There is much energy stored in the balancing device. Therefore a special procedure is required to dismantle it. The coil springs inside the balancing device exert a potentially lethal force unless dismantled properly.

The device must be dismantled by a decommissioning company.

Required equipment

Equipment	Art. no.	Note
Standard toolkit	-	Content is defined in section Standard tools on page 406 .
Cutting torch		For opening housing and cutting coils
Other tools and procedures may be required. See references to these procedures in the step-by-step instructions below.		These procedures include references to the tools required.



DANGER

Do not under any circumstances, deal with the balancing device in any other way than that detailed in the product documentation! For example, attempting to open the balancing device is potentially lethal!

Action on field, decommissioning

The procedure below details the actions to perform on field, when the balancing device is to be decommissioned.

	Action	Note
1	Remove the balancing device from the robot.	Detailed in section Removal, balancing device on page 285 .
2	Send the device to a decommissioning company.	Make sure the decommissioning company is well informed about the stored energy built up by high tensioned compression springs and that the device contains some grease. The following procedure contains useful information about decommissioning.

Continues on next page

6 Decommissioning

6.4 Decommissioning of balancing device

Continued

Decommissioning at decommissioning company, balancing device

The instruction below details how to decommission the balancing device. Contact ABB Robotics for further consultation.

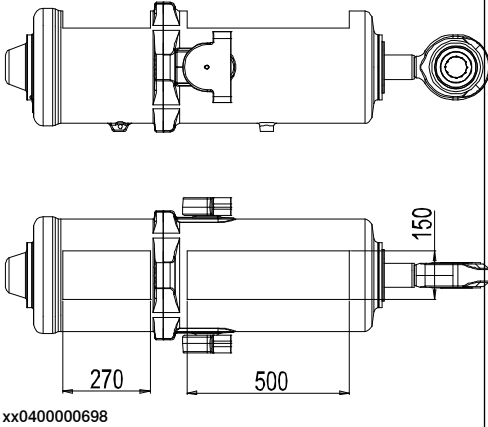
	Action	Note
1	 <p>DANGER</p> <p>There is stored energy built up by high tensioned compression springs inside the balancing device! The device also contains some grease!</p>	
2	<p>Place the device on a workbench or similar. Make sure it is clamped in position with a vice or similar.</p>	
3	<p>Open a hole in the side of the housing as shown in the figure.</p>	<p>Use a cutting torch. The measurements shown below are maximum values!</p>  <p>xx0400000698</p>
4	<p>Cut the coils of the three springs inside the housing as specified below:</p> <ul style="list-style-type: none"> • Outer spring: cut at least five coils! • Middle spring: cut at least four coils! • Inner spring: cut at least four coils! 	<p>Use a cutting torch.</p>
5	<p>Double-check the number of coils cut and make sure all the tension in the springs is removed.</p>	

7 Robot description

7.1 Type A vs type B motors

Identifying the motor visually

Type B motors include evacuation on the motor flange to indicate failure of primary sealing between the gearbox and the motor. Robots with protection type Foundry Plus have a sight glass installed in the evacuation holes.

Use the images to identify which type of motor is installed on each robot axis.

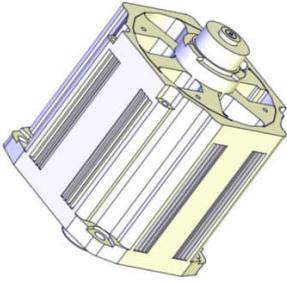
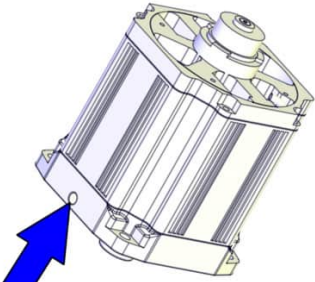
Type A motor	Type B motor
 <p>xx1500001058</p>	 <p>xx1500001057</p>
No evacuation on type A motors.	The type B motor include evacuation on the motor flange.

Identifying the motor by article number

Use the table to identify which type of motor is installed on each robot axis by article number. The article numbers specified are found in WebConfig.

Contact ABB Service for further assistance regarding which motor type is installed on the robot, if needed.

The columns for reach refer to the robot variant designation.



Note

The article numbers in the table can not be used for ordering spare parts. The numbers are only used for identification of installed motors.

See *Product manual, spare parts - IRB 6650S* for spare part numbers.

Robot axis	Article number Type A motor	Article number Type B motor
1	3HAC057550-001	3HAC062343-001
2	3HAC057551-001	3HAC062344-001
3	3HAC057546-001	3HAC062345-001
	3HAC058883-001 (Foundry Prime)	N/A
4	3HAC057547-001	3HAC062346-001
	3HAC058885-001 (Foundry Prime)	N/A

Continues on next page

7 Robot description

7.1 Type A vs type B motors

Continued

Robot axis	Article number Type A motor	Article number Type B motor
5	3HAC057548-001	3HAC062335-001
	3HAC058886-001 (Foundry Prime)	N/A
6	3HAC057549-001	3HAC062348-001
	3HAC058887-001 (Foundry Prime)	N/A

Interchangeable parts

Use the table to see if type A and type B motors are interchangeable on each robot axis.

Robot axis	Motor replacement from type A to type B	Requirements/notes for replacing type A motor with type B motor
1	Fully interchangeable.	
2	Fully interchangeable.	
3	Fully interchangeable.	
4	Fully interchangeable.	
5	Fully interchangeable.	
6	Fully interchangeable.	

8 Spare part lists

8.1 Spare part lists and illustrations

Location

Spare parts and exploded views are not included in the manual but delivered as a separate document for registered users on myABB Business Portal, www.abb.com/myABB.



Tip

All documents can be found via myABB Business Portal, www.abb.com/myABB.

This page is intentionally left blank

9 Reference information

9.1 Introduction

General

This chapter includes general information, complementing the more specific information in the different procedures in the manual.

9 Reference information

9.2 Applicable standards

9.2 Applicable standards

General

The product is compliant with ISO 10218-1:2011, *Robots for industrial environments - Safety requirements - Part 1 Robots*, and applicable parts in the normative references, as referred to from ISO 10218-1:2011. In case of deviation from ISO 10218-1:2011, these are listed in the declaration of incorporation. The declaration of incorporation is part of the delivery.

Robot standards

Standard	Description
ISO 9283	Manipulating industrial robots – Performance criteria and related test methods
ISO 9787	Robots and robotic devices – Coordinate systems and motion nomenclatures
ISO 9946	Manipulating industrial robots – Presentation of characteristics

Other standards used in design

Standard	Description
IEC 60204-1	Safety of machinery - Electrical equipment of machines - Part 1: General requirements, normative reference from ISO 10218-1
IEC 61000-6-2	Electromagnetic compatibility (EMC) – Part 6-2: Generic standards – Immunity standard for industrial environments
IEC 61000-6-4	Electromagnetic compatibility (EMC) – Part 6-4: Generic standards – Emission standard for industrial environments
ISO 13849-1:2006	Safety of machinery - Safety related parts of control systems - Part 1: General principles for design, normative reference from ISO 10218-1

Region specific standards and regulations

Standard	Description
ANSI/RIA R15.06	Safety requirements for industrial robots and robot systems
ANSI/UL 1740	Safety standard for robots and robotic equipment
CAN/CSA Z 434-03	Industrial robots and robot Systems - General safety requirements
EN ISO 10218-1	Robots and robotic devices — Safety requirements for industrial robots — Part 1: Robots

9.3 Unit conversion

Converter table

Use the following table to convert units used in this manual.

Quantity	Units		
Length	1 m	3.28 ft.	39.37 in
Weight	1 kg	2.21 lb.	
Weight	1 g	0.035 ounces	
Pressure	1 bar	100 kPa	14.5 psi
Force	1 N	0.225 lbf	
Moment	1 Nm	0.738 lbf-ft	
Volume	1 L	0.264 US gal	

9 Reference information

9.4 Screw joints

9.4 Screw joints

General

This section describes how to tighten the various types of screw joints on ABB robots.

The instructions and torque values are valid for screw joints comprised of metallic materials and do *not* apply to soft or brittle materials.

UNBRAKO screws

UNBRAKO is a special type of screw recommended by ABB for certain screw joints. It features special surface treatment (Gleitmo as described below) and is extremely resistant to fatigue.

Whenever used, this is specified in the instructions, and in such cases, *no other type of replacement screw* is allowed. Using other types of screws will void any warranty and may potentially cause serious damage or injury.

Gleitmo treated screws

Gleitmo is a special surface treatment to reduce the friction when tightening the screw joint. It is recommended by ABB for M6-M20 screw joints. Screws treated with Gleitmo may be reused 3-4 times before the coating disappears. After this the screw must be discarded and replaced with a new one.

When handling screws treated with Gleitmo, protective gloves of nitrile rubber type should be used.

Generally, screws are lubricated with *Gleitmo 603* mixed with *Geomet 500* or *Geomet 702* in proportion 1:3. *Geomet* thickness varies according to screw dimensions, refer to the following.

Dimension	Lubricant	Geomet thickness
M6-M20 (any length except M20x60)	<i>Gleitmo 603 + Geomet 500</i>	3-5 µm
M6-M20 (any length except M20x60)	<i>Gleitmo 603 + Geomet 720</i>	3-5 µm
M20x60	<i>Gleitmo 603 + Geomet 500</i>	8-12 µm
M20x60	<i>Gleitmo 603 + Geomet 720</i>	6-10 µm

Screws lubricated in other ways

Screws lubricated with Molykote 1000 or Molykote P1900 should *only* be used when specified in the repair, maintenance or installation procedure descriptions.

In such cases, proceed as follows:

- 1 Apply lubricant to the screw thread.
- 2 Apply lubricant between the plain washer and screw head.
- 3 Screw dimensions of M8 or larger must be tightened with a torque wrench. Screw dimensions of M6 or smaller may be tightened without a torque wrench *if* this is done by trained and qualified personnel.

Continues on next page

Lubricant	Article number
Molykote 1000 (molybdenum disulphide grease)	3HAC042472-001
Molykote P1900 (molybdenum disulphide grease)	3HAC070875-001

Tightening torque

Before tightening any screw, note the following:

- Determine whether a **standard** tightening torque or **special** torque is to be applied. The **standard torques** are specified in the following tables. Any **special torques** are specified in the repair, maintenance or installation procedure descriptions. **Any special torque specified overrides the standard torque!**
- Use the *correct tightening torque* for each type of screw joint.
- Only use *correctly calibrated* torque keys.
- *Always tighten the joint by hand*, and never use pneumatic tools.
- Use the *correct tightening technique*, that is *do not* jerk. Tighten the screw in a slow, flowing motion.
- Maximum allowed total deviation from the specified value is **10%!**

Tightening torque for oil-lubricated screws with slotted or cross-recess head screws

The following table specifies the recommended standard tightening torque for *oil-lubricated screws with slotted or cross-recess head screws*.



Note

A special torque specified in the repair, maintenance or installation procedure overrides the standard torque.

Tightening torque for oil-lubricated screws with allen head screws

The following table specifies the recommended standard tightening torque for *oil-lubricated screws with allen head screws*.



Note

A special torque specified in the repair, maintenance or installation procedure overrides the standard torque.

Dimension	Tightening torque (Nm) Class 8.8, oil-lubricated	Tightening torque (Nm) Class 10.9, oil-lubricated	Tightening torque (Nm) Class 12.9, oil-lubricated
M5	6	-	-
M6	10	-	-
M8	24	34	40
M10	47	67	80
M12	82	115	140
M16	200	290	340
M20	400	560	670

Continues on next page

9 Reference information

9.4 Screw joints

Continued

Dimension	Tightening torque (Nm) Class 8.8, oil-lubricated	Tightening torque (Nm) Class 10.9, oil-lubricated	Tightening torque (Nm) Class 12.9, oil-lubricated
M24	680	960	1150

Tightening torque for lubricated screws (Molykote, Gleitmo or equivalent) with allen head screws
The following table specifies the recommended standard tightening torque for *screws lubricated with Molykote 1000, Gleitmo 603 or equivalent with allen head screws.*



Note

A special torque specified in the repair, maintenance or installation procedure overrides the standard torque.

Dimension	Tightening torque (Nm) Class 10.9, lubricated ⁱ	Tightening torque (Nm) Class 12.9, lubricated ⁱ
M5		8
M6		14
M8	28	35
M10	55	70
M12	96	120
M16	235	300
M20	460	550
M24	790	950

ⁱ Lubricated with Molykote 1000, Gleitmo 603 or equivalent

Water and air connectors

The following table specifies the recommended standard tightening torque for *water and air connectors* when *one or both* connectors are made of *brass*.



Note

A special torque specified in the repair, maintenance or installation procedure overrides the standard torque.

Dimension	Tightening torque Nm - Nominal	Tightening torque Nm - Min.	Tightening torque Nm - Max.
1/8	12	8	15
1/4	15	10	20
3/8	20	15	25
1/2	40	30	50
3/4	70	55	90

9.5 Weight specifications

Definition

In installation, repair, and maintenance procedures, weights of the components handled are sometimes specified. All components exceeding 22 kg (50 lbs) are highlighted in this way.

To avoid injury, ABB recommends the use of a lifting accessory when handling components with a weight exceeding 22 kg. A wide range of lifting accessories and devices are available for each manipulator model.

Example

Following is an example of a weight specification in a procedure:

Action	Note
 CAUTION The arm weighs 25 kg. All lifting accessories used must be sized accordingly.	

9 Reference information

9.6 Standard tools

9.6 Standard tools

General

All service (repairs, maintenance, and installation) procedures contains lists of tools required to perform the specified activity.

All special tools required are listed directly in the procedures while all the tools that are considered standard are gathered in the standard toolkit and defined in the following table.

This way, the tools required are the sum of the standard toolkit and any tools listed in the instruction.

Contents, standard toolkit

Qty	Tool	Rem.
1	Ring-open-end spanner 8-19 mm	
1	Socket head cap 5-17 mm	
1	Torx socket no: 20-60	
1	Box spanner set	
1	Torque wrench 10-100 Nm	
1	Torque wrench 75-400 Nm	
1	Ratchet head for torque wrench 1/2	
2	Hexagon-headed screw M10x100	
1	Hex bit socket head cap no. 14 socket 40 mm L=100 mm	
1	Hex bit socket head cap no. 14 socket 40 mm L=20 mm	To be shortened to 12 mm
1	Hex bit socket head cap no. 6 socket 40 mm L=145 mm	
1	Hex bit socket head cap no. 6 socket 40mm bit L=220 mm	

9.7 Special tools

General

All service instructions contain lists of tools required to perform the specified activity. The required tools are a sum of standard tools, defined in the section [Standard tools on page 406](#), and of special tools, listed directly in the instructions and also gathered in this section.

Basic tools

The following table specifies the tools in the basic toolkit (3HAC15571-3) that are used for the current robot model. This toolkit is necessary primary when removing and refitting the motors.

The tools are also listed directly in the instructions.

Description	Qty	Art. no.
Guide pins M8 x 100	2	3HAC15520-1
Guide pins M8 x 150	2	3HAC15520-2
Guide pins M10 x 100	2	3HAC15521-1
Guide pins M10 x 150	2	3HAC15521-2
Lifting tool, wrist unit	1	3HAC13605-1
Lifting tool, motor ax 1, 4, 5	1	3HAC14459-1
Lifting tool, motor ax 2, 3, 4	1	3HAC15534-1
Removal tool, motor M10x	2	3HAC14972-1 Fits motors, axes 4, 5 and 6.
Removal tool, motor M12x	2	3HAC14631-1 Fits motors axes 1, 2 and 3.
Rotation tool	1	3HAC17105-1
Mechanical stop axis 3	2	3HAC12708-1
Bolts M16 x 60 (for mechanical stop axis 3)	2	3HAB3409-86
Washers (for mechanical stop axis 3)	2	3HAA1001-186
Standard toolkit (content described in section Standard tools on page 406)	1	3HAC15571-1

Special tools

The following table specifies the special tools required during several of the service procedures. The tools may be ordered separately and are also specified directly in concerned instructions in the product manual.

Description	Qty	Art. no.
Fixture lower arm	1	3HAC020729-001
Gearbox crank, axis 2	1	3HAC020999-001
Guide pins M12 x 130	2	3HAC022637-001
Guide pins M12 x 150	2	3HAC13056-2
Guide pins M12 x 200	2	3HAC13056-3

Continues on next page

9 Reference information

9.7 Special tools

Continued

Description	Qty	Art. no.
Guide pins M12 x 250	1	3HAC13056-4
Guide pins M16 x 300	2	3HAC13120-5
Guide pins, sealing ax 2/3, 100mm	1	3HAC14628-2
Guide pins, sealing ax 2/3, 80mm	1	3HAC14628-1
Holder for bits (Stahlwille 736/40 S 5/16")	1	3HAC029090-001
Hydraulic cylinder	2	3HAC11731-1
Hydraulic pump, 80 MPa	1	3HAC13086-1
Hydraulic pump, 150 MPa (Glycerin)	1	3HAC021563-012
Hydraulic valve with hose	1	3HAC022643-001
Lifting accessory, base	1	3HAC15560-1
Lifting accessory, robot	1	3HAC15607-1
Lifting accessory, upper arm	1	3HAC15994-1
Lifting eye VLBG M12	1	3HAC16131-1
Lifting eye M12	2	3HAC14457-3
Lifting eye M16	2	3HAC14457-4
Lifting tool (chain)	1	3HAC15556-1
Lifting tool, gearbox axis 2 and axis 3	1	3HAC020386-001
Lifting tool (chain), Balancing device	1	3HAC020540-001
Measuring tool	1	6896134-GN
Oil injector / max 500 MPa	1	3HAC021590-001
Press tool, axis 2 bearing	1	3HAC076203-001
Puller device, axis 2 shaft	1	3HAC075427-001
Press device, axis 2 shaft	1	3HAC076203-001
Press equipment, balancing device	1	3HAC074411-001
Adapter Used together with press equipment for balancing devices from 2002 and older.	1	3HAC078221-001
Press equipment, balancing device shaft	1	3HAC076202-001
Shackle, balancing device	1	3HAC020997-001
Support, base	1	3HAC15535-1
Tool set balancing device	1	3HAC021984-001

Tools that may be rented

The following table specifies the tools that may be rented from ABB in order to perform certain service procedures as described in the Product manual.

The special tools are also listed directly in the instructions.

Description	Art. no.	Note
Lifting tool, lower arm	3HAC14691-1	Includes <ul style="list-style-type: none"> Guidances, 3HAC14446-1

Continues on next page

Calibration equipment, Levelmeter (alternative method)

The following table specifies the calibration equipment required when calibrating the robot with the alternative method, Levelmeter Calibration.

Description	Art. no.	Note
Angle bracket	68080011-LP	
Calibration bracket	3HAC13908-9	
Calibration tool ax1	3HAC13908-4	
Measuring pin	3HAC13908-5	
Sensor fixture	68080011-GM	
Sensor plate	3HAC0392-1	
Sync. adapter	3HAC13908-1	

Calibration equipment, Axis Calibration

The following table specifies the calibration equipment needed when calibrating the robot with the Axis Calibration method.

Description	Art. no.	Note
Calibration tool box, Axis Calibration	3HAC055412-001	Delivered as a set of calibration tools. Required if Axis Calibration is the valid calibration method for the robot.

Oil exchange equipment

The following table specifies the recommended equipment for oil exchange.

Description	Art. no.	Note
Oil exchange equipment	3HAC021745-001	Includes: <ul style="list-style-type: none"> • Vacuum pump with regulator, hose and coupling • Couplings and adapters • Pump (manual) with hose and coupling • Graduated measuring glass • Oil gun • User instructions.

9 Reference information

9.8 Lifting accessories and lifting instructions

9.8 Lifting accessories and lifting instructions

General

Many repair and maintenance activities require different pieces of lifting accessories, which are specified in each procedure.

The use of each piece of lifting accessories is *not* detailed in the activity procedure, but in the instruction delivered with each piece of lifting accessories.

The instructions delivered with the lifting accessories should be stored for later reference.

10 Circuit diagram

10.1 Circuit diagrams

Overview

The circuit diagrams are not included in this manual, but are available for registered users on myABB Business Portal, www.abb.com/myABB.

See the article numbers in the tables below.

Controllers

Product	Article numbers for circuit diagrams
<i>Circuit diagram - OmniCore V250XT</i>	<i>3HAC074000-008</i>
<i>Circuit diagram - IRC5</i>	<i>3HAC024480-011</i>
<i>Circuit diagram - IRC5 Panel Mounted Controller</i>	<i>3HAC026871-020</i>

Manipulators

Product	Article numbers for circuit diagrams
<i>Circuit diagram - IRB 120</i>	<i>3HAC031408-003</i>
<i>Circuit diagram - IRB 140 type C</i>	<i>3HAC6816-3</i>
<i>Circuit diagram - IRB 260</i>	<i>3HAC025611-001</i>
<i>Circuit diagram - IRB 360</i>	<i>3HAC028647-009</i>
<i>Circuit diagram - IRB 390</i>	<i>3HAC060545-009</i>
<i>Circuit diagram - IRB 460</i>	<i>3HAC036446-005</i>
<i>Circuit diagram - IRB 660</i>	<i>3HAC025691-001</i>
<i>Circuit diagram - IRB 760</i>	<i>3HAC025691-001</i>
<i>Circuit diagram - IRB 1200</i>	<i>3HAC046307-003</i>
<i>Circuit diagram - IRB 1410</i>	<i>3HAC2800-3</i>
<i>Circuit diagram - IRB 1600/1660</i>	<i>3HAC021351-003</i>
<i>Circuit diagram - IRB 1520</i>	<i>3HAC039498-007</i>
<i>Circuit diagram - IRB 2400</i>	<i>3HAC6670-3</i>
<i>Circuit diagram - IRB 2600</i>	<i>3HAC029570-007</i>
<i>Circuit diagram - IRB 4400/4450S</i>	<i>3HAC9821-1</i>
<i>Circuit diagram - IRB 4600</i>	<i>3HAC029038-003</i>
<i>Circuit diagram - IRB 6620</i>	<i>3HAC025090-001</i>
<i>Circuit diagram - IRB 6620 / IRB 6620LX</i>	<i>3HAC025090-001</i>
<i>Circuit diagram - IRB 6640</i>	<i>3HAC025744-001</i>
<i>Circuit diagram - IRB 6650S</i>	<i>3HAC13347-1</i> <i>3HAC025744-001</i>

Continues on next page

10 Circuit diagram

10.1 Circuit diagrams

Continued

Product	Article numbers for circuit diagrams
<i>Circuit diagram - IRB 6660</i>	<i>3HAC025744-001 3HAC029940-001</i>
<i>Circuit diagram - IRB 6700 / IRB 6790</i>	<i>3HAC043446-005</i>
<i>Circuit diagram - IRB 7600</i>	<i>3HAC13347-1 3HAC025744-001</i>
<i>Circuit diagram - IRB 14000</i>	<i>3HAC050778-003</i>
<i>Circuit diagram - IRB 910SC</i>	<i>3HAC056159-002</i>

Use the correct circuit diagram (IRB 6600, IRB 6650 and IRB 6650S)

The cable harness of the robot is available in two different designs. Either the cabling is divided between the upper and lower arm, or not. Accordingly there are also two different versions of the circuit diagram. Decide which circuit diagram is valid for the robot by checking the article number for the cable harness.

10.2 Circuit diagram 3HAC 025744-001

10.2.1 Validity of circuit diagram 3HAC025744-1

Is this circuit diagram valid for your robot?

The validity of the circuit diagram depends on which cable harness is fitted to the robot.

Check the article number of the cable harness fitted to the robot and see page 3 of the circuit diagram in order to determine if the diagram is valid for the harness or not.

Where to find the article number	Action
Label on the cable harness	The label is located at the connectors in the base. Remove the rear cover plate to see the label.
WebConfig	

10 Circuit diagram

10.3.1 Validity of circuit diagram 3HAC13347-1

10.3 Circuit diagram 3HAC 13347-1

10.3.1 Validity of circuit diagram 3HAC13347-1

Is this circuit diagram valid for your robot?

The validity of the circuit diagram depends on which cable harness is fitted to the robot.

Check the article number of the cable harness fitted to the robot.

Where to find the article number	Action
Label on the cable harness	The label is located at the connectors in the base. Remove the rear cover plate to see the label.
WebConfig	-

This circuit diagram is valid for the following cable harness assemblies:

Robot	Cable harness	Revision
IRB 6600	3HAC 14940-1	all
IRB 6650, IRB 6650S	3HAC 16331-1	all
IRB 7600	3HAC 14940-1	revision 0-2

For remaining cable harness assemblies, see section [Validity of circuit diagram 3HAC025744-1 on page 413](#).

Index

A

- Absolute Accuracy, calibration, 361
- additional mechanical stop location, 146
- allergenic material, 32
- aluminum
 - disposal, 390
- ambient humidity
 - operation, 47
 - storage, 47
- ambient temperature
 - operation, 47
 - storage, 47
- assembly instructions, 43
- assessment of hazards and risks, 32
- Axis Calibration, 372
 - calibration tool
 - article number, 375, 378
 - examining, 375
 - installation position, 377
 - overview of method, 372
 - procedure on FlexPendant, 378, 384
 - protective cover and protection plug, 377–378

B

- balancing device, replacement, 282
- balancing device bearing, replacement, 279
- base plate
 - guide pins, 67
 - securing, 67
- batteries
 - disposal, 390
- battery
 - replacing, 173, 272
- battery pack
 - replacing, interval, 113
- battery shutdown
 - service routine, 173, 272
- brake release, 64
- brake release board, replacement, 275
- brakes
 - testing function, 40
- buttons for brake release, 64

C

- cabinet lock, 33
- cable harness axes 1-6, replacement, 192
- cable harness axes 1-4, replacement, 208
- cabling, robot, 104
- cabling, robot axes 1-4, 209
- cabling, robot axes 5-6, 219
- cabling axis 5, replacement, 223
- cabling between robot and controller, 103
- calibrating
 - robot, 372
 - roughly, 366, 370
- calibrating robot, 372, 384
- calibration
 - Absolute Accuracy type, 360
 - alternative method, 361
 - Levelmeter calibration, 361
 - rough, 366, 370
 - standard type, 360
 - verification, 386
 - when to calibrate, 363

- calibration, Absolute Accuracy, 361
- calibration manuals, 362
- calibration marks, 364
- calibration position
 - jogging to, 387–388
 - scales, 364
- calibration scales, 364
- CalibWare, 360
- carbon dioxide extinguisher, 33
- cast iron
 - disposal, 390
- changing oil
 - axis 1, 155
- cleaning, 179
- climbing on robot, 36
- Cold environments, 107
- complete arm system, replacement, 225
- connecting the robot and controller, cabling, 103
- copper
 - disposal, 390

D

- damage to additional mechanical stop, 146
- damage to mechanical stop, 144
- dimensions
 - frame, 78
 - lower arm, 75
 - upper arm, 77
- direction of axes, 365

E

- environmental information, 390
- EPS, 96
- equipment on robot, 75
- ESD
 - damage elimination, 54
 - sensitive equipment, 54
- expected life, 114
- extended working range, 96
- extended working range, axis 1, 96
- extra equipment
 - frame, 78
 - lower arm, 75
 - robot, 75
 - upper arm, 77

F

- fire extinguishing, 33
- fitting equipment on robot, 75
- FlexPendant
 - jogging to calibration position, 387–388
 - MoveAbsJ instruction, 387–388
 - updating revolution counters, 367, 370
- fork lift, 55
- foundation
 - requirements, 47
- frame
 - dimensions, 78

G

- gearbox
 - oil change axis 1, 155
- gearbox axis 1, replacement, 328
- gearbox axis 2, replacement, 339
- gearbox axis 3, replacement, 346
- gearbox axis 6, replacement, 353
- gearboxes

- location of, 153
- grease, 36
 - disposal, 390
- guide pins, base plate, 67

H

- hanging
 - installed hanging, 32
- hazard levels, 23
- hazardous material, 390
- height
 - installed at a height, 32
- hot surfaces, 36
- HRA, 32
- humidity
 - operation, 47
 - storage, 47

I

- information labels location, 142
- inspecting
 - additional mechanical stop, 146
 - information labels, 142
 - mechanical stop, 144
 - motor seal, 115
- inspecting oil levels
 - axis-6, 128
 - axis-5, 126
 - axis-4, 124
 - axis-3, 121
 - axis-2, 119
 - axis-1, 117
- installation
 - mechanical stop axis 1, 94
 - mechanical stop axis 2, 98
 - mechanical stop axis 3, 100
- installing equipment on robot, 75
- instructions for assembly, 43
- integrator responsibility, 32
- intervals for maintenance, 111

L

- labels
 - robot, 25
- leak-down test, 184
- Levelmeter calibration, 361
- lifting accessory, 405
- lifting accessory, robot, 62
- lifting robot
 - with fork lift, 55
 - with lifting accessory, 62
 - with roundslings, 60
- lifting upper arm
 - attachment points for lifting accessory, 241
- limitation of liability, 21
- Lithium
 - disposal, 390
- loads on foundation, 46
- lock and tag, 33
- lower arm
 - dimensions, 75
 - replacement, 250
- lower arm shaft, replacement, 260
- lubricants, 36
- lubrication
 - amount in gearboxes, 153
 - type of lubrication, 153

M

- magnesium
 - disposal, 390
- maintenance schedule, 111
- manually releasing brakes, 64
- mechanical stop
 - axis 1, 94
 - axis 2, 98
 - axis 3, 100
- mechanical stop location, 144
- motion of axes, 52
- motor axis 1, replacement, 294
- motor axis 2, replacement, 299
- motor axis 3, replacement, 305
- motor axis 4, replacement, 311
- motor axis 5, replacement, 316
- motor axis 6, replacement, 322
- motor seal
 - inspecting, 115
- MoveAbsJ instruction, 387–388

N

- national regulations, 32
- negative directions, axes, 365
- neodymium
 - disposal, 390
- nodular iron
 - disposal, 390

O

- oil, 36
 - amount in gearboxes, 153
 - disposal, 390
 - type of oil, 153
- oil change
 - axis 1, 155
- oil level
 - gearbox axis-6, 128
 - gearbox axis-5, 126
 - gearbox axis-4, 124
 - gearbox axis-3, 121
 - gearbox axis-2, 119
 - gearbox axis-1, 117
- operating conditions, 47
- option
 - Extended working range, 96
- original spare parts, 21

P

- pedestal
 - installed on pedestal, 32
- personnel
 - requirements, 22
- plastic
 - disposal, 390
- positive directions, axes, 365
- PPE, 22
- product standards, 400
- protection classes, 48
- protection type, 48
- protective equipment, 22
- protective wear, 22

R

- radius, turning, 52
- range of movement, 52
- recycling, 390

- regional regulations, 32
- release brakes, 39
- replacement
 - balancing device, 282
 - bearing, balancing device, 279
 - brake release board, 275
 - cable harness axes 1-6, 192
 - cable harness axes 1-4, 208
 - cabling axis 5, 223
 - complete arm system, 225
 - gearbox axis 1, 328
 - gearbox axis 2, 339
 - gearbox axis 3, 346
 - gearbox axis 6, 353
 - lower arm, 250
 - lower arm shaft, 260
 - motor axis 1, 294
 - motor axis 2, 299
 - motor axis 3, 305
 - motor axis 4, 311
 - motor axis 5, 316
 - motor axis 6, 322
 - turning disk, 231
 - upper arm, 241
 - wrist unit, 235
- replacements, report, 183
- report replacements, 183
- requirements on foundation, 47
- responsibility and validity, 21
- restricting
 - working range axis 1, 94, 96
 - working range axis 2, 98
 - working range axis 3, 100
- revolution counters
 - storing on FlexPendant, 367, 370
 - updating, 366, 370
- risk of burns, 36
- risk of tipping, 53
- robot
 - labels, 25
 - protection class, 48
 - protection types, 48
 - symbols, 25
- rubber
 - disposal, 390
- S**
- safety
 - brake testing, 40
 - ESD, 54
 - fire extinguishing, 33
 - release robot axes, 39
 - signal lamp, 81
 - signals, 23
 - signals in manual, 23
 - symbols, 23
 - symbols on robot, 25
 - test run, 108
- safety devices, 33
- safety equipment
 - mechanical stop, 94
 - mechanical stop axis 2, 98
 - mechanical stop axis 3, 100
 - signal lamp, 151
- safety hazard
 - hydraulic system, 34
 - pneumatic system, 34
- safety signals
 - in manual, 23
- safety standards, 400
- scales on robot, 364
- schedule for maintenance, 111
- screw joints, 402
- securing
 - base plate, 67
 - securing, lower arm, 268
 - securing, robot, 72
 - securing, upper arm, 307
- securing the robot to foundation, attachment screws, 72
- shipping, 389
- signal lamp, 81
- signals
 - safety, 23
- SMB
 - replacing, 272
- SMB battery
 - extension of lifetime, 173, 272
 - replacing, 173, 272
- special tools, 407
- speed
 - adjusting, 107
- stability, 53
- standards, 400
 - ANSI, 400
 - CAN, 400
- start of robot in cold environments, 107
- steel
 - disposal, 390
- storage conditions, 47
- symbols
 - safety, 23
- synchronization position, 366, 370
- sync marks, 364
- system integrator requirements, 32
- T**
- temperatures
 - operation, 47
 - storage, 47
- testing
 - brakes, 40
- tightening torque
 - mechanical stop axis 2, 99
- tools
 - Axis Calibration, 409
 - calibration equipment, Levelmeter, 409
 - for service, 407
 - oil exchange equipment, 409
- torques on foundation, 46
- transportation, 389
- troubleshooting
 - oil spills, 179
 - safety, 41
- turning disk replacement, 231
- turning radius, 52
- type A motors, 395
- type B motors, 395
- type of motion, 52
- U**
- upcycling, 390
- updating revolution counters, 366, 370
- upper arm
 - dimensions, 77

replacement, 241

users

requirements, 22

V

validity and responsibility, 21

velocity

adjusting, 107

verifying calibration, 386

W

weight, 45

balancing device, 285, 289

base plate, 66, 71

gearbox, 342, 344, 349–350

lower arm, 257–258

motor, 296–297, 308–309

robot, 59–60, 63, 331, 333, 335, 338

upper arm, 246–247

wrist unit, 238

working range, 49

restricting axis 1, 94

restricting axis 2, 98

restricting axis 3, 100

Wrist Optimization

overview of method, 384

wrist unit, replacement, 235

Z

zero position

checking, 387



ABB AB

Robotics & Discrete Automation

S-721 68 VÄSTERÅS, Sweden

Telephone +46 10-732 50 00

ABB AS

Robotics & Discrete Automation

Nordlysvegen 7, N-4340 BRYNE, Norway

Box 265, N-4349 BRYNE, Norway

Telephone: +47 22 87 2000

ABB Engineering (Shanghai) Ltd.

Robotics & Discrete Automation

No. 4528 Kangxin Highway

PuDong New District

SHANGHAI 201319, China

Telephone: +86 21 6105 6666

ABB Inc.

Robotics & Discrete Automation

1250 Brown Road

Auburn Hills, MI 48326

USA

Telephone: +1 248 391 9000

abb.com/robotics