

ROBOTICS

Product manual

IRB 6700Inv / IRB 6700I

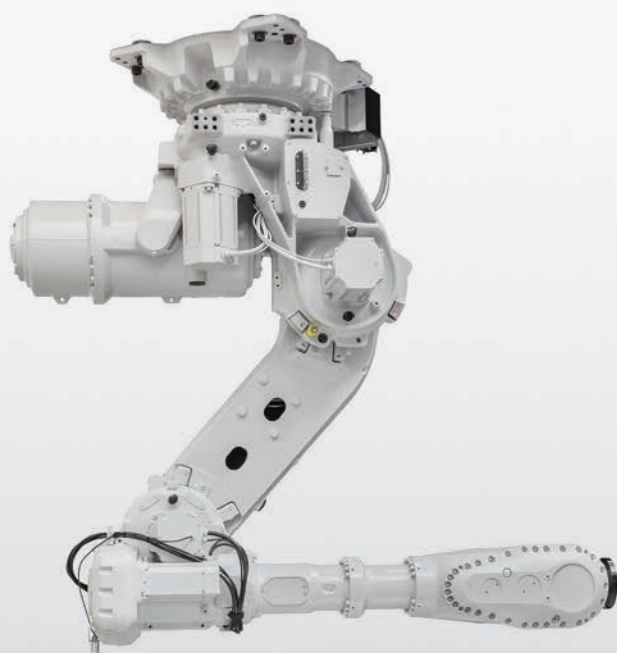

Trace back information:
Workspace 23C version a19
Checked in 2023-10-04
Skribenta version 5.5.019

Product manual

IRB 6700Inv - 300/2.60
IRB 6700I - 270/2.60 LID
IRB 6700Inv - 245/2.90
IRB 6700I - 210/2.90 LID

IRC5, OmniCore

Document ID: 3HAC058254-001

Revision: T

The information in this manual is subject to change without notice and should not be construed as a commitment by ABB. ABB assumes no responsibility for any errors that may appear in this manual.

Except as may be expressly stated anywhere in this manual, nothing herein shall be construed as any kind of guarantee or warranty by ABB for losses, damage to persons or property, fitness for a specific purpose or the like.

In no event shall ABB be liable for incidental or consequential damages arising from use of this manual and products described herein.

This manual and parts thereof must not be reproduced or copied without ABB's written permission.

Keep for future reference.

Additional copies of this manual may be obtained from ABB.

Original instructions.

© Copyright 2017 - 2023 ABB. All rights reserved.
Specifications subject to change without notice.

Table of contents

Overview of this manual	9
Product documentation	14
How to read the product manual	16
1 Safety	17
1.1 Safety information	17
1.1.1 Limitation of liability	17
1.1.2 Requirements on personnel	18
1.2 Safety signals and symbols	19
1.2.1 Safety signals in the manual	19
1.2.2 Safety symbols on manipulator labels	21
1.3 Robot stopping functions	28
1.4 Safety during installation and commissioning	29
1.5 Safety during operation	32
1.6 Safety during maintenance and repair	33
1.6.1 Safety during maintenance and repair	33
1.6.2 Emergency release of the robot axes	36
1.6.3 Brake testing	37
1.7 Safety during troubleshooting	38
1.8 Safety during decommissioning	39
2 Installation and commissioning	41
2.1 Introduction to installation and commissioning	41
2.2 Unpacking	42
2.2.1 Pre-installation procedure	42
2.2.2 Technical data	43
2.2.3 Working range	46
2.2.4 Risk of tipping/stability	50
2.2.5 Main dimensions	52
2.2.6 The unit is sensitive to ESD	54
2.3 On-site transportation	55
2.3.1 Robot transportation precautions	55
2.3.2 Securing the robot arm position for lift, rotation and transportation	56
2.4 On-site installation	59
2.4.1 Brief installation procedure	59
2.4.2 Lifting the robot	60
2.4.2.1 Lifting the robot with fork lift	60
2.4.2.2 Lifting and rotating a suspended mounted or tilted manipulator	61
2.4.2.3 Lifting the robot with roundslings	62
2.4.3 Orienting, rotating and securing the robot	66
2.4.4 Manually releasing the brakes	70
2.4.5 Loads fitted to the robot, stopping time and braking distances	72
2.4.6 Fitting equipment to the robot	73
2.5 Restricting the working range	82
2.5.1 Axes with restricted working range	82
2.5.2 Mechanically restricting the working range of axis 1	83
2.6 Electrical connections	85
2.6.1 Robot cabling and connection points	85
2.7 Installation of options	89
2.7.1 Safety lamp (option for IRC5)	89
2.7.2 Installing the motor cooling fan (option)	90
2.8 Start of robot in cold environments	96
2.9 Test run after installation, maintenance, or repair	97
3 Maintenance	99
3.1 Introduction	99

Table of contents

3.2	Maintenance schedule and expected component life	100
3.2.1	Specification of maintenance intervals	100
3.2.2	Maintenance schedule	101
3.2.3	Expected component life	103
3.3	Inspection activities	104
3.3.1	Inspecting the motor seal	104
3.3.2	Inspecting the oil level in axis-1 gearbox	106
3.3.3	Inspecting the oil level in axis-2 gearbox	111
3.3.4	Inspecting the oil level in axis-3 gearbox	113
3.3.5	Inspecting the oil level in axis-4 gearbox	116
3.3.6	Inspecting the oil level in axis-5 gearbox	119
3.3.7	Inspecting the oil level in axis-6 gearbox	122
3.3.8	Inspecting the balancing device	125
3.3.9	Inspecting the cable harness	129
3.3.10	Inspecting the information labels	132
3.3.11	Inspecting the transportation lock screw	138
3.3.12	Inspecting the axis-1 mechanical stop pin	140
3.3.13	Inspecting the additional mechanical stops	141
3.3.14	Inspecting the dampers	143
3.3.15	Inspecting the signal lamp (option)	145
3.4	Replacement/changing activities	147
3.4.1	Type of lubrication in gearboxes	147
3.4.2	Changing oil, axis-1 gearbox	149
3.4.3	Changing oil, axis-2 gearbox	156
3.4.4	Changing oil, axis-3 gearbox	162
3.4.5	Changing oil, axis-4 gearbox	167
3.4.6	Changing oil, axis-5 gearbox	171
3.4.7	Changing oil, axis-6 gearbox	175
3.4.8	Replacing the SMB battery	179
3.5	Lubrication activities	182
3.5.1	Lubricating the spherical roller bearing, balancing device	182
3.6	Cleaning activities	184
3.6.1	Cleaning the IRB 6700Inv / IRB 6700I	184
4	Repair	187
4.1	Introduction	187
4.2	General procedures	188
4.2.1	Performing a leak-down test	188
4.2.2	Mounting instructions for bearings	189
4.2.3	Mounting instructions for sealings	191
4.2.4	Service stops	195
4.2.5	Cut the paint or surface on the robot before replacing parts	197
4.2.6	The brake release buttons may be jammed after service work	198
4.3	Lifting associated procedures	199
4.3.1	Attaching lifting accessories to complete arm system	199
4.3.2	Attaching lifting accessories to an un-separated lower and upper arm	206
4.3.3	Attaching lifting accessories to the upper arm	210
4.3.4	Lifting down the manipulator from inverted to floor-standing position	213
4.4	Complete robot	217
4.4.1	Removing the cable harness	217
4.4.2	Refitting the cable harness	240
4.4.3	Replacing the SMB	268
4.4.4	Replacing the brake release unit	274
4.5	Upper and lower arms	279
4.5.1	Replacing the upper arm	279
4.5.2	Replacing the wrist	315
4.5.3	Replacing the turning disc	336
4.5.4	Replacing the process turning disc	340
4.5.5	Replacing the lower arm	343

4.6	Frame and base	403
4.6.1	Replacing the spherical roller bearing	403
4.6.2	Replacing the balancing device	417
4.6.3	Replacing the rear bearings on the balancing device	441
4.6.4	Replacing the stop pin	458
4.7	Motors	461
4.7.1	Replacing the axis-1 motor	461
4.7.2	Replacing the axis-2 motor	475
4.7.3	Replacing the axis-3 motor	488
4.7.4	Replacing the axis-4 motor	501
4.7.5	Replacing the axis-5 motor	513
4.7.6	Replacing the axis-6 motor	528
4.8	Gearboxes	543
4.8.1	Replacing the hub	543
4.8.2	Replacing the axis-1 gearbox	565
4.8.3	Replacing the axis-2 gearbox	612
4.8.4	Replacing the axis-3 gearbox	653
4.8.5	Replacing the axis-6 gearbox	675
5	Calibration	683
5.1	Introduction to calibration	683
5.1.1	Introduction and calibration terminology	683
5.1.2	Calibration methods	684
5.1.3	When to calibrate	686
5.2	Synchronization marks and axis movement directions	687
5.2.1	Synchronization marks and synchronization position for axes	687
5.2.2	Calibration movement directions for all axes	689
5.3	Updating revolution counters	690
5.3.1	Updating revolution counters on IRC5 robots	690
5.3.2	Updating revolution counters on OmniCore robots	693
5.4	Calibrating with Axis Calibration method	694
5.4.1	Description of Axis Calibration	694
5.4.2	Calibration tools for Axis Calibration	697
5.4.3	Installation locations for the calibration tools	699
5.4.4	Axis Calibration - Running the calibration procedure	700
5.4.5	Reference calibration	704
5.5	Calibrating with Wrist Optimization method	706
5.6	Verifying the calibration	708
5.7	Checking the synchronization position	709
6	Decommissioning	711
6.1	Introduction to decommissioning	711
6.2	Environmental information	712
6.3	Scrapping of robot	714
6.4	Decommissioning of balancing device	715
7	Reference information	717
7.1	Introduction	717
7.2	Applicable standards	718
7.3	Unit conversion	719
7.4	Screw joints	720
7.5	Weight specifications	723
7.6	Standard toolkit	724
7.7	Special tools	725
7.8	Lifting accessories and lifting instructions	730
8	Spare parts	731
8.1	Spare part lists and illustrations	731

Table of contents

9	Circuit diagrams	733
9.1	Circuit diagrams	733
Index		735

Overview of this manual

About this manual

This manual contains instructions for:

- mechanical and electrical installation of the IRB 6700Inv / IRB 6700I
- maintenance of the IRB 6700Inv / IRB 6700I
- mechanical and electrical repair of the IRB 6700Inv / IRB 6700I

The robot described in this manual has the following protection types:

- *Standard*
- *Foundry Plus*

This manual describes the manipulator using either the IRC5 or the OmniCore controller.

Product manual scope

The manual covers all variants and designs of the IRB 6700Inv / IRB 6700I. Some variants and designs may have been removed from the business offer and are no longer available for purchase.

Usage

This manual should be used during:

- installation and commissioning, from lifting the product to its work site and securing it to the foundation, to making it ready for operation
- maintenance work
- repair work
- decommissioning work



Note

It is the responsibility of the integrator to conduct a risk assessment of the final application.

It is the responsibility of the integrator to provide safety and user guides for the robot system.

Who should read this manual?

This manual is intended for:

- installation personnel
 - maintenance personnel
 - repair personnel.
-

Prerequisites

A maintenance/repair/installation craftsman working with an ABB robot must:

- be trained by ABB and have the required knowledge of mechanical and electrical installation/repair/maintenance work.
 - be trained to respond to emergencies or abnormal situations.
-

Continues on next page

Overview of this manual

Continued

References

Documentation referred to in the manual, is listed below.

General

Document name	Document ID
<i>Product manual, spare parts - IRB 6700/IRB 6700Inv</i>	<i>3HAC044268-001</i>
<i>Circuit diagram - IRB 6700 / IRB 6790</i>	<i>3HAC043446-005</i>
<i>Technical reference manual - Lubrication in gearboxes</i>	<i>3HAC042927-001</i>
<i>Directions for use - Fork lift accessory set 3HAC058825-001</i>	<i>3HAC060303-001</i>
<i>Product manual - DressPack/SpotPack IRB 6700</i>	<i>3HAC044270-001</i>
<i>Safety manual for robot - Manipulator and IRC5 or OmniCore controllerⁱ</i>	<i>3HAC031045-001</i>

ⁱ This manual contains all safety instructions from the product manuals for the manipulators and the controllers.

For OmniCore robots

Document name	Document ID
<i>Product specification - IRB 6700</i>	<i>3HAC080365-001</i>
<i>Product manual - OmniCore V250XT Type A</i>	<i>3HAC084692-001</i>
<i>Product manual - OmniCore V250XT</i>	<i>3HAC073447-001</i>
<i>Operating manual - OmniCore</i>	<i>3HAC065036-001</i>
<i>Technical reference manual - System parameters</i>	<i>3HAC065041-001</i>

For IRC5 robots

Document name	Document ID
<i>Product specification - IRB 6700</i>	<i>3HAC044265-001</i>
<i>Product manual - IRC5</i> For IRC5 robots, with main computer DSQC1000.	<i>3HAC047136-001</i>
<i>Operating manual - IRC5 with FlexPendant</i>	<i>3HAC050941-001</i>
<i>Technical reference manual - System parameters</i>	<i>3HAC050948-001</i>

Revisions

Revision	Description
-	First edition.

Continues on next page

Revision	Description
A	<p>Published in release R17.1+. The following updates are made in this revision:</p> <ul style="list-style-type: none"> • Method of axis-3 gearbox replacement completed with information about replacing the gearbox without removing the cabling. • Lifting method of arm system updated during replacement of axis-1 gearbox. • Lifting method of upper arm updated during replacement of upper arm or axis-3 gearbox. • Information about Minimum resonance frequency added. • Bending radius for static floor cables added. • Minor additions/corrections made in repair procedures for sections: <ul style="list-style-type: none"> - Refitting of axis-2 gearbox - Lifting down the robot from inverted position • Applicable standards updated • Safety symbol for moving robot is updated with dual direction of axis-2 movement. • Added text regarding overhaul in section specification of maintenance intervals. • Added article number for grease Castrol Molub-Alloy 777-1, used for hub splines. • Section Start of robot in cold environments on page 96 added. • Updated information regarding replacement of brake release board. • Corrected value of tightening torque for additional mechanical stops.
B	<p>Published in release R17.2. The following updates are made in this revision:</p> <ul style="list-style-type: none"> • Updated information regarding disconnecting and reconnecting battery cable to serial measurement board. • Information about high stress on mounting screws added. • Repair procedure for axis-1 gearbox is updated regarding removal of VK covers, small o-ring beneath the gearbox and applying flange sealant. • Definition of reference calibration clarified.
C	<p>Published in release R18.1. The following updates are made in this revision:</p> <ul style="list-style-type: none"> • Information added about fatigue to Axis Calibration tool, see Calibration tools for Axis Calibration on page 697. • Added sections in General procedures on page 188. • Safety restructured. • The procedure for replacing the axis-3 gearbox is changed to using a loose pinion as a tool during refitting of the upper arm. • Added photos showing the appearance of the protection filter and the transparent plug on motor oil evacuation hole. • Note added to calibration chapter to emphasize the requirement of equally dressed robot when using previously created reference calibration values. • Information about myABB Business Portal added. • Installation information of cooling fan for the axis-1 motor added.
D	<p>Published in release R18.2. The following updates are made in this revision:</p> <ul style="list-style-type: none"> • Added article number for axis-3 pinion tool. • Adjustments in repair section.

Continues on next page

Revision	Description
E	Published in release R18.2. The following updates are made in this revision: <ul style="list-style-type: none"> Updated references.
F	Published in release 19B. The following updates are made in this revision: <ul style="list-style-type: none"> New touch up color Graphite White available. See Cut the paint or surface on the robot before replacing parts on page 197. New article numbers for manipulator cables in section Robot cabling and connection points on page 85.
G	Published in release 19D. The following updates are made in this revision: <ul style="list-style-type: none"> Corrected article number for guide pin M12x200 and removal tool M12. Deleted guide pin M12x250 from special tool list.
H	Published in release 20A. The following updates are made in this revision: <ul style="list-style-type: none"> Added new protection plug for the front link ear. Replaced article number and name of grease, previously 3HAB3537-1. Clarified and added information in mounting instructions for rotating sealings, see Mounting instructions for sealings on page 191. Clarified text about position of robot and added table with dependencies between axes during Axis Calibration.
J	Published in release 20B. The following updates are made in this revision: <ul style="list-style-type: none"> Added information about Wrist Optimization in calibration chapter.
K	Published in release 20C. The following updates are made in this revision: <ul style="list-style-type: none"> Added hub tool to the replacement procedure for the hub. Pallet removed from required tools tables.
L	Published in release 20D. The following updates are made in this revision: <ul style="list-style-type: none"> Corrected article number for axis-6 gearbox o-ring.
M	Published in release 21C. The following updates are made in this revision: <ul style="list-style-type: none"> User instructions for the dismantle and mounting tool (3HAC028920-001) is now enclosed with the toolkit. User instructions are removed from this manual. Text regarding fastener quality is updated, see Fastener quality on page 81. Removal tool Axis 1 motor 3HAC055444-001 is changed to 3HAC062250-001.
N	Published in release 21D. The following updates are made in this revision: <ul style="list-style-type: none"> Added information for the OmniCore robot controller.
P	Published in release 22A. The following updates are made in this revision: <ul style="list-style-type: none"> Oil change interval is corrected in maintenance schedule. Updated information about Gleitmo treated screws, see Screw joints on page 720. Updated image of roundslings attached to lifting shackle. Removed information about inspecting fork lift accessories. Information is found in enclosed documentation for the fork lift accessories.
Q	Published in release 22B. The following updates are done in this revision: <ul style="list-style-type: none"> Added information about always replacing the o-rings on oil plugs with new o-rings when refitting the plugs. Added LID robot variants throughout the manual (valid for OmniCore robot controller).

Revision	Description
R	<p>Published in release 22D. The following updates are done in this revision:</p> <ul style="list-style-type: none"> • Changed tightening torque from 24 Nm to 10 Nm on stop screw, mechanical stop pin axis 1. • Added a step for overall inspection of cabling after cable harness has been replaced. • Removed section about lifting the manipulator with lifting accessory for floor-mounted robots. • Added section about lifting and rotating the manipulator to inverted position with special lifting accessory.
S	<p>Published in release 23B. The following updates are done in this revision:</p> <ul style="list-style-type: none"> • Added section Test run after installation, maintenance, or repair on page 97. • Added a step in motor replacement procedures for replacing the protection filter with sight glass on new spare part motors for manipulators with protection type Foundry Plus. • Added axis positions for most stable transport position and removed information about shipping position. • Updates made based on feedback from University.
T	<p>Published in release 23C. The following updates are done in this revision:</p> <ul style="list-style-type: none"> • Added missing information for attachment holes.

Product documentation

Categories for user documentation from ABB Robotics

The user documentation from ABB Robotics is divided into a number of categories. This listing is based on the type of information in the documents, regardless of whether the products are standard or optional.



Tip

All documents can be found via myABB Business Portal, www.abb.com/myABB.

Product manuals

Manipulators, controllers, DressPack, and most other hardware is delivered with a **Product manual** that generally contains:

- Safety information.
- Installation and commissioning (descriptions of mechanical installation or electrical connections).
- Maintenance (descriptions of all required preventive maintenance procedures including intervals and expected life time of parts).
- Repair (descriptions of all recommended repair procedures including spare parts).
- Calibration.
- Troubleshooting.
- Decommissioning.
- Reference information (safety standards, unit conversions, screw joints, lists of tools).
- Spare parts list with corresponding figures (or references to separate spare parts lists).
- References to circuit diagrams.

Technical reference manuals

The technical reference manuals describe reference information for robotics products, for example lubrication, the RAPID language, and system parameters.

Application manuals

Specific applications (for example software or hardware options) are described in **Application manuals**. An application manual can describe one or several applications.

An application manual generally contains information about:

- The purpose of the application (what it does and when it is useful).
- What is included (for example cables, I/O boards, RAPID instructions, system parameters, software).
- How to install included or required hardware.
- How to use the application.

Continues on next page

- Examples of how to use the application.

Operating manuals

The operating manuals describe hands-on handling of the products. The manuals are aimed at those having first-hand operational contact with the product, that is production cell operators, programmers, and troubleshooters.

How to read the product manual

Reading the procedures

The procedures contain all information required for the installation or service activity and can be printed out separately when needed for a certain service procedure.

Safety information

The manual includes a separate safety chapter that must be read through before proceeding with any service or installation procedures. All procedures also include specific safety information when dangerous steps are to be performed.

Read more in the chapter [Safety on page 17](#).

Illustrations

The product is illustrated with general figures that does not take painting or protection type in consideration.

Likewise, certain work methods or general information that is valid for several product models, can be illustrated with illustrations that show a different product model than the one that is described in the current manual.

1 Safety

1.1 Safety information

1.1.1 Limitation of liability

Limitation of liability

Any information given in this manual regarding safety must not be construed as a warranty by ABB that the industrial robot will not cause injury or damage even if all safety instructions are complied with.

The information does not cover how to design, install and operate a robot system, nor does it cover all peripheral equipment that can influence the safety of the robot system.

In particular, liability cannot be accepted if injury or damage has been caused for any of the following reasons:

- Use of the robot in other ways than intended.
- Incorrect operation or maintenance.
- Operation of the robot when the safety devices are defective, not in their intended location or in any other way not working.
- When instructions for operation and maintenance are not followed as intended.
- Non-authorized design modifications of the robot.
- Repairs on the robot and its spare parts carried out by in-experienced or non-qualified personnel.
- Foreign objects.
- Force majeure.

Spare parts and equipment

ABB supplies original spare parts and equipment which have been tested and approved for their intended use. The installation and/or use of non-original spare parts and equipment can negatively affect the safety, function, performance, and structural properties of the robot. ABB is not liable for damages caused by the use of non-original spare parts and equipment.

1 Safety

1.1.2 Requirements on personnel

1.1.2 Requirements on personnel

General

Only personnel with appropriate training are allowed to install, maintain, service, repair, and use the robot. This includes electrical, mechanical, hydraulics, pneumatics, and other hazards identified in the risk assessment.

Persons who are under the influence of alcohol, drugs or any other intoxicating substances are not allowed to install, maintain, service, repair, or use the robot.

The plant liable must make sure that the personnel is trained on the robot, and on responding to emergency or abnormal situations.

Personal protective equipment

Use personal protective equipment, as stated in the instructions.

1.2 Safety signals and symbols

1.2.1 Safety signals in the manual







Introduction to safety signals

This section specifies all safety signals used in the user manuals. Each signal consists of:

- A caption specifying the hazard level (DANGER, WARNING, or CAUTION) and the type of hazard.
- Instruction about how to reduce the hazard to an acceptable level.
- A brief description of remaining hazards, if not adequately reduced.

Hazard levels

The table below defines the captions specifying the hazard levels used throughout this manual.

Symbol	Designation	Significance
	DANGER	Signal word used to indicate an imminently hazardous situation which, if not avoided, will result in serious injury.
	WARNING	Signal word used to indicate a potentially hazardous situation which, if not avoided, could result in serious injury.
	ELECTRICAL SHOCK	Signal word used to indicate a potentially hazardous situation related to electrical hazards which, if not avoided, could result in serious injury.
	CAUTION	Signal word used to indicate a potentially hazardous situation which, if not avoided, could result in slight injury.
	ELECTROSTATIC DISCHARGE (ESD)	Signal word used to indicate a potentially hazardous situation which, if not avoided, could result in severe damage to the product.
	NOTE	Signal word used to indicate important facts and conditions.

Continues on next page

1 Safety

1.2.1 Safety signals in the manual

Continued

Symbol	Designation	Significance
	TIP	Signal word used to indicate where to find additional information or how to do an operation in an easier way.

1.2.2 Safety symbols on manipulator labels

Introduction to symbols

This section describes safety symbols used on labels (stickers) on the manipulator. Symbols are used in combinations on the labels, describing each specific warning. The descriptions in this section are generic, the labels can contain additional information such as values.



Note

The symbols on the labels on the product must be observed. Additional symbols added by the integrator must also be observed.



Types of symbols

Both the manipulator and the controller are marked with symbols, containing important information about the product. This is important for all personnel handling the robot, for example during installation, service, or operation.

The safety labels are language independent, they only use graphics. See [Symbols on safety labels on page 21](#).

The information labels can contain information in text.

Symbols on safety labels



Symbol	Description
 xx0900000812	Warning! Warns that an accident <i>may</i> occur if the instructions are not followed that can lead to serious injury, possibly fatal, and/or great damage to the product. It applies to warnings that apply to danger with, for example, contact with high voltage electrical units, explosion or fire risk, risk of poisonous gases, risk of crushing, impact, fall from height, etc.
 xx0900000811	Caution! Warns that an accident may occur if the instructions are not followed that can result in injury and/or damage to the product. It also applies to warnings of risks that include burns, eye injury, skin injury, hearing damage, crushing or slipping, tripping, impact, fall from height, etc. Furthermore, it applies to warnings that include function requirements when fitting and removing equipment where there is a risk of damaging the product or causing a breakdown.
 xx0900000839	Prohibition Used in combinations with other symbols.

Continues on next page

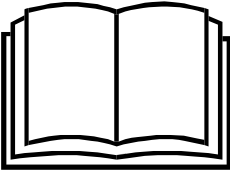
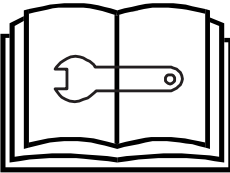
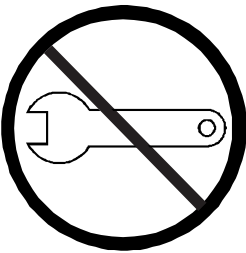
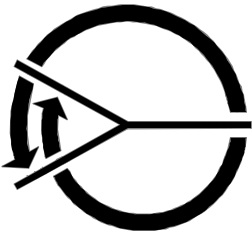

1 Safety

1.2.2 Safety symbols on manipulator labels

Continued

Symbol	Description
 xx0900000813	See user documentation Read user documentation for details. Which manual to read is defined by the symbol: <ul style="list-style-type: none">• No text: <i>Product manual</i>.• EPS: <i>Application manual - Electronic Position Switches</i>.
 xx0900000816	Before disassembly, see product manual
 xx0900000815	Do not disassemble Disassembling this part can cause injury.
 xx0900000814	Extended rotation This axis has extended rotation (working area) compared to standard.
 xx0900000808	Brake release Pressing this button will release the brakes. This means that the robot arm can fall down.

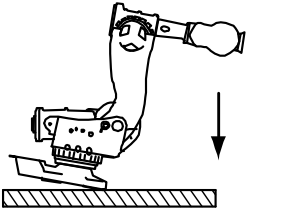

Continues on next page

Symbol	Description
 <p>xx0900000810</p> <p>3HAC 057068-001</p> <p>xx1500002402</p>	<p>Tip risk when loosening bolts The robot can tip over if the bolts are not securely fastened.</p>
 <p>xx0900000817</p>	<p>Crush Risk of crush injuries.</p>

1 Safety

1.2.2 Safety symbols on manipulator labels

Continued

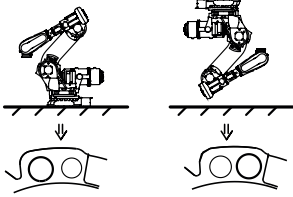
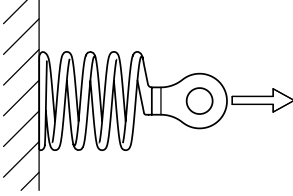
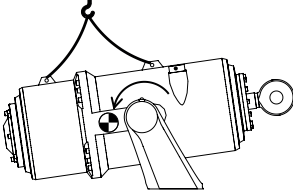
Symbol	Description
 <p>xx0900000818</p>  <p>xx1300001087</p>	<p>Heat Risk of heat that can cause burns. (Both signs are used)</p>
 <p>xx1700000518</p>	<p>Risk of lower arm movement when robot is floor mounted Use transportation lock screw when moving, transporting or rotating robot.</p>
 <p>xx1700000519</p>	<p>Pressurized balancing device Release of the axis-2 motor holding brakes can cause the axis 2 to move in opposite direction in regard to gravity, due to the pushing force from the balancing device. Current arm load and position of the lower and upper arm determines the occurring movement when releasing the holding brakes of the axis-2 motor.</p>
 <p>xx1700000520</p>	<p>Lifting of balancing device Center of gravity will cause the balancing device to tip over when released in the front ear.</p>



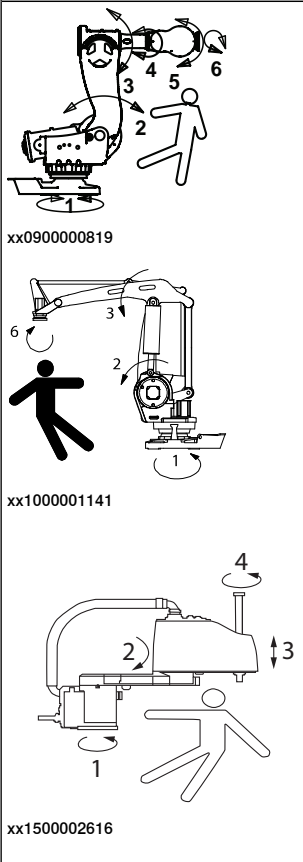
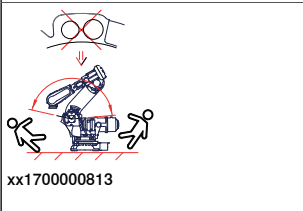
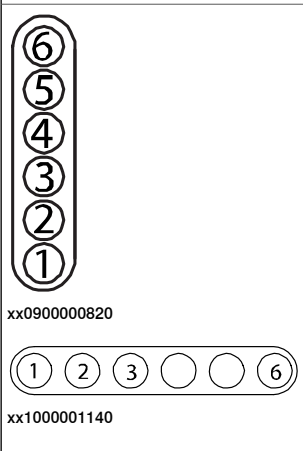
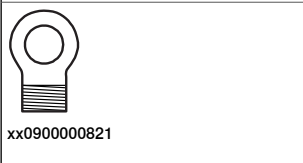



Continues on next page

Symbol	Description
 <p>xx0900000819</p> <p>xx1000001141</p> <p>xx1500002616</p>	<p>Moving robot The robot can move unexpectedly.</p>
 <p>xx1700000813</p>	<p>Moving robot The robot can move unexpectedly when floor standing. Always use transportation lock screw in floor standing position.</p>
 <p>xx0900000820</p> <p>xx1000001140</p>	<p>Brake release buttons</p>
 <p>xx0900000821</p>	<p>Lifting bolt</p>

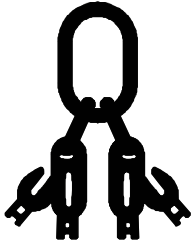

1 Safety

1.2.2 Safety symbols on manipulator labels

Continued

Symbol	Description
 xx1000001242	Adjustable chain sling with shortener
 xx0900000822	Lifting of robot
 xx0900000823	Oil Can be used in combination with prohibition if oil is not allowed.
 xx0900000824	Mechanical stop
 xx1000001144	No mechanical stop
 xx0900000825	Stored energy Warns that this part contains stored energy. Used in combination with <i>Do not disassemble</i> symbol.

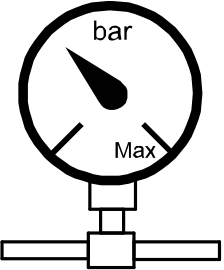
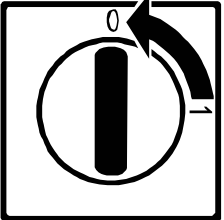
Continues on next page

Symbol	Description
 <p data-bbox="451 589 563 607">xx0900000826</p>	<p data-bbox="759 315 863 338">Pressure</p> <p data-bbox="759 349 1436 405">Warns that this part is pressurized. Usually contains additional text with the pressure level.</p>
 <p data-bbox="451 882 563 900">xx0900000827</p>	<p data-bbox="759 647 991 669">Shut off with handle</p> <p data-bbox="759 680 1190 703">Use the power switch on the controller.</p>
 <p data-bbox="451 1189 563 1207">xx1400002648</p>	<p data-bbox="759 940 895 963">Do not step</p> <p data-bbox="759 974 1436 1030">Warns that stepping on these parts can cause damage to the parts.</p>

1 Safety

1.3 Robot stopping functions

1.3 Robot stopping functions

Protective stop and emergency stop

The protective stops and emergency stops are described in the product manual for the controller.

For more information see:

- *Product manual - OmniCore V250XT*
- *Product manual - OmniCore V250XT Type A*
- *Product manual - IRC5*
- *Product manual - IRC5 Panel Mounted Controller*

1.4 Safety during installation and commissioning

National or regional regulations

The integrator of the robot system is responsible for the safety of the robot system.

The integrator is responsible that the robot system is designed and installed in accordance with the safety requirements set forth in the applicable national and regional standards and regulations.

The integrator of the robot system is required to perform a risk assessment.

Layout

The robot integrated to a robot system shall be designed to allow safe access to all spaces during installation, operation, maintenance, and repair.

If robot movement can be initiated from an external control panel then an emergency stop must also be available.

If the manipulator is delivered with mechanical stops, these can be used for reducing the working space.

A perimeter safeguarding, for example a fence, shall be dimensioned to withstand the following:

- The force of the manipulator.
- The force of the load handled by the robot if dropped or released at maximum speed.
- The maximum possible impact caused by a breaking or malfunctioning rotating tool or other device fitted to the robot.

The maximum TCP speed and the maximum velocity of the robot axes are detailed in the section *Robot motion* in the product specification for the respective manipulator.

Consider exposure to hazards, such as slipping, tripping, and falling.

Hazards due to the working position and posture for a person working with or near the robot shall be considered.

Hazards due to noise emission from the robot needs to be considered.

Consider hazards from other equipment in the robot system, for example, that guards remain active until identified hazards are reduced to an acceptable level.

Allergenic material

See [Environmental information on page 712](#) for specification of allergenic materials in the product, if any.

Securing the robot to the foundation

The robot must be properly fixed to its foundation/support, as described in the respective product manual.

When the robot is installed at a height, hanging, or other than mounted directly on the floor, there will be additional hazards.

Continues on next page

1 Safety

1.4 Safety during installation and commissioning

Continued

Electrical safety

Incoming mains must be installed to fulfill national regulations.

The power supply wiring to the robot must be sufficiently fused and if necessary, it must be possible to disconnect it manually from the mains power.

The power to the robot must be turned off with the main switch and the mains power disconnected when performing work inside the controller cabinet. Lock and tag shall be considered.

Harnesses between controller and manipulator shall be fixed and protected to avoid tripping and wear.

Wherever possible, power on/off or rebooting the robot controller shall be performed with all persons outside the safeguarded space.



Note

Use a CARBON DIOXIDE (CO₂) extinguisher in the event of a fire in the robot.

Safety devices

The integrator is responsible for that the safety devices necessary to protect people working with the robot system are designed and installed correctly.

When integrating the robot with external devices to a robot system:

- The integrator of the robot system must ensure that emergency stop functions are interlocked in accordance with applicable standards.
- The integrator of the robot system must ensure that safety functions are interlocked in accordance with applicable standards.

Other hazards

A robot may perform unexpected limited movement.



WARNING

Manipulator movements can cause serious injuries on users and may damage equipment.

The risk assessment should also consider other hazards arising from the application, such as, but not limited to:

- Water
- Compressed air
- Hydraulics

End-effector hazards require particular attention for applications which involve close human collaboration with the robot.

Continues on next page

Pneumatic or hydraulic related hazards



Note

The pressure in the complete pneumatic or hydraulic systems must be released before service and maintenance.

All components in the robot system that remain pressurized after switching off the power to the robot must be marked with clearly visible drain facilities and a warning sign that indicates the hazard of stored energy.

Loss of pressure in the robot system may cause parts or objects to drop.

Dump valves should be used in case of emergency.

Shot bolts should be used to prevent tools, etc., from falling due to gravity.

All pipes, hoses, and connections have to be inspected regularly for leaks and damage. Damage must be repaired immediately.

Verify the safety functions

Before the robot system is put into operation, verify that the safety functions are working as intended and that any remaining hazards identified in the risk assessment are mitigated to an acceptable level.

1 Safety

1.5 Safety during operation

1.5 Safety during operation

Automatic operation

Verify the application in the operating mode manual reduced speed, before changing mode to automatic and initiating automatic operation.

Unexpected movement of robot arm



WARNING

Hazards due to the use of brake release devices and/or gravity beneath the manipulator shall be considered.

A robot may perform unexpected limited movement.



WARNING

Manipulator movements can cause serious injuries on users and may damage equipment.

1.6 Safety during maintenance and repair

1.6.1 Safety during maintenance and repair

General

Corrective maintenance must only be carried out by personnel trained on the robot. Maintenance or repair must be done with all electrical, pneumatic, and hydraulic power switched off, that is, no remaining hazards.

Hazards due to stored mechanical energy in the manipulator for the purpose of counterbalancing axes must be considered before maintenance or repair.

Never use the robot as a ladder, which means, do not climb on the controller, manipulator, including motors, or other parts. There are hazards of slipping and falling. The robot might be damaged.

Make sure that there are no tools, loose screws, turnings, or other unexpected parts remaining after maintenance or repair work.

When the work is completed, verify that the safety functions are working as intended.

Hot surfaces

Surfaces can be hot after running the robot, and touching these may result in burns. Allow the surfaces to cool down before maintenance or repair.

Allergic reaction

Warning	Description	Elimination/Action
 Allergic reaction	When working with lubricants there is a risk of an allergic reaction.	Make sure that protective gear like goggles and gloves are always worn.

Gearbox lubricants (oil or grease)

When handling oil, grease, or other chemical substances the safety information of the respective manufacturer must be observed.



Note

Take special care when handling hot lubricants.







Warning	Description	Elimination/Action
 Hot oil or grease	Changing and draining gearbox oil or grease may require handling hot lubricant heated up to 90 °C.	Make sure that protective gear like goggles and gloves are always worn during this activity.

Continues on next page

1 Safety

1.6.1 Safety during maintenance and repair

Continued

Warning	Description	Elimination/Action
 <p>Allergic reaction</p>	When working with lubricants there is a risk of an allergic reaction.	Make sure that protective gear like goggles and gloves are always worn.
 <p>Possible pressure build-up in gearbox</p>	When opening the oil or grease plug, there may be pressure present in the gearbox, causing lubricant to spray from the opening.	Open the plug carefully and keep away from the opening. Do not overfill the gearbox when filling.
 <p>Do not overfill</p>	Overfilling of gearbox lubricant can lead to internal over-pressure inside the gearbox which in turn may: <ul style="list-style-type: none"> • damage seals and gaskets • completely press out seals and gaskets • prevent the robot from moving freely. 	Make sure not to overfill the gearbox when filling it with oil or grease. After filling, verify that the level is correct.
 <p>Do not mix types of oil</p>	Mixing types of oil may cause severe damage to the gearbox.	When filling gearbox oil, do not mix different types of oil unless specified in the instructions. Always use the type of oil specified for the product.
 <p>Oil residues</p>	Oil residues might be present in a drained gearbox and spilled when separating a motor and gearbox during repair.	Make sure that protective gear like goggles/protective visor, gloves and arm protection are always worn during this activity. Put oil absorbent cloth or paper at appropriate locations to catch any oil residues.
 <p>Heat up the oil</p>	Warm oil drains quicker than cold oil.	Run the robot before changing the gearbox oil, if possible.
 <p>Specified amount depends on drained volume</p>	The specified amount of oil or grease is based on the total volume of the gearbox. When changing the lubricant, the amount refilled may differ from the specified amount, depending on how much has previously been drained from the gearbox.	After filling, verify that the level is correct.

Continues on next page

Warning	Description	Elimination/Action
 Contaminated oil in gearboxes	For lifetime reasons always drain as much oil as possible from the gearbox. The magnetic oil plugs will gather residual metal chips.	

Hazards related to batteries

Under rated conditions, the electrode materials and liquid electrolyte in the batteries are sealed and not exposed to the outside.

There is a hazard in case of abuse (mechanical, thermal, electrical) which leads to the activation of safety valves and/or the rupture of the battery container. As a result under certain circumstances, electrolyte leakage, electrode materials reaction with moisture/water or battery vent/explosion/fire may follow.

Do not short circuit, recharge, puncture, incinerate, crush, immerse, force discharge or expose to temperatures above the declared operating temperature range of the product. Risk of fire or explosion.

Operating temperatures are listed in [Operating conditions, robot on page 45](#).

See safety instructions for the batteries in *Material/product safety data sheet - Battery pack (3HAC043118-001)*.

Unexpected movement of robot arm



WARNING

Hazards due to the use of brake release devices and/or gravity beneath the manipulator shall be considered.

A robot may perform unexpected limited movement.



WARNING

Manipulator movements can cause serious injuries on users and may damage equipment.

Related information

See also the safety information related to installation and operation.

1 Safety

1.6.2 Emergency release of the robot axes

1.6.2 Emergency release of the robot axes

Description

In an emergency situation, the brakes on a robot axis can be released manually by pushing a brake release button.

How to release the brakes is described in the section:

- [Manually releasing the brakes on page 70](#).

The robot may be moved manually on smaller robot models, but larger models may require using an overhead crane or similar equipment.

Increased injury

Before releasing the brakes, make sure that the weight of the manipulator does not result in additional hazards, for example, even more severe injuries on a trapped person.

Make sure that stored energy from the balancing device does not result in additional hazards, such as even more severe injuries on a trapped person.



DANGER

When releasing the holding brakes, the robot axes may move very quickly and sometimes in unexpected ways.

Release of the axis-2 motor holding brakes can cause the axis 2 to move in opposite direction in regard to gravity, due to the pushing force from the balancing device. Current arm load and position of the lower and upper arm determines the occurring movement when releasing the holding brakes of the axis-2 motor.

Make sure no personnel is near or beneath the robot.

1.6.3 Brake testing

When to test

During operation, the holding brake of each axis normally wears down. A test can be performed to determine whether the brake can still perform its function.

How to test

The function of the holding brake of each axis motor may be verified as described below:

- 1 Run each axis to a position where the combined weight of the manipulator and any load is maximized (maximum static load).
- 2 Switch the motor to the MOTORS OFF.
- 3 Inspect and verify that the axis maintains its position.

If the manipulator does not change position as the motors are switched off, then the brake function is adequate.



Note

It is recommended to run the service routine *BrakeCheck* as part of the regular maintenance, see the operating manual for the robot controller.

For robots with the option SafeMove, the *Cyclic Brake Check* routine is recommended. See the manual for SafeMove in [References on page 10](#).

1 Safety

1.7 Safety during troubleshooting

1.7 Safety during troubleshooting

General

When troubleshooting requires work with power switched on, special considerations must be taken:

- Safety circuits might be muted or disconnected.
- Electrical parts must be considered as *live*.
- The manipulator can move unexpectedly at any time.



DANGER

Troubleshooting on the controller while powered on must be performed by personnel trained by ABB or by ABB field engineers.



CAUTION

Risk of hot surfaces that can cause burns.

A risk assessment must be done to address both robot and robot system specific hazards.



WARNING

Hazards due to the use of brake release devices and/or gravity beneath the manipulator shall be considered.

A robot may perform unexpected limited movement.



WARNING

Manipulator movements can cause serious injuries on users and may damage equipment.

Related information

See also the safety information related to installation, operation, maintenance, and repair.

1.8 Safety during decommissioning

General

See section [Decommissioning on page 711](#).

If the robot is decommissioned for storage, take extra precaution to reset safety devices to delivery status.

Unexpected movement of robot arm



WARNING

Hazards due to the use of brake release devices and/or gravity beneath the manipulator shall be considered.

A robot may perform unexpected limited movement.



WARNING

Manipulator movements can cause serious injuries on users and may damage equipment.

This page is intentionally left blank

2 Installation and commissioning

2.1 Introduction to installation and commissioning

General

This chapter contains assembly instructions and information for installing the IRB 6700Inv / IRB 6700I at the working site.

See also the product manual for the robot controller.

The installation must be done by qualified installation personnel in accordance with the safety requirements set forth in the applicable national and regional standards and regulations.

The technical data is detailed in section [Technical data on page 43](#).

Safety information

Before any installation work is commenced, all safety information must be observed. There are general safety aspects that must be read through, as well as more specific safety information that describes the danger and safety risks when performing the procedures. Read the chapter [Safety on page 17](#) before performing any installation work.



Note

Always connect the IRB 6700Inv / IRB 6700I and the robot to protective earth and residual current device (RCD) before connecting to power and starting any installation work.

For more information see:

- *Product manual - OmniCore V250XT*
- *Product manual - OmniCore V250XT Type A*
- *Product manual - IRC5*
- *Product manual - IRC5 Panel Mounted Controller*

2 Installation and commissioning

2.2.1 Pre-installation procedure

2.2 Unpacking

2.2.1 Pre-installation procedure

Introduction

This section is intended for use when unpacking and installing the robot for the first time. It also contains information useful during later re-installation of the robot.

Prerequisites for installation personnel

Installation personnel working with an ABB product must:

- be trained by ABB and have the required knowledge of mechanical and electrical installation/maintenance/repair work
- conform to all national and local codes.

Checking the pre-requisites for installation

	Action
1	Make a visual inspection of the packaging and make sure that nothing is damaged.
2	Remove the packaging.
3	Check for any visible transport damage.  Note Stop unpacking and contact ABB if transport damages are found.
4	Clean the unit with a lint-free cloth, if necessary.
5	Make sure that the lifting accessory used (if required) is suitable to handle the weight of the robot as specified in: Weight, robot on page 43
6	If the robot is not installed directly, it must be stored as described in: Storage conditions, robot on page 45
7	Make sure that the expected operating environment of the robot conforms to the specifications as described in: Operating conditions, robot on page 45
8	Before taking the robot to its installation site, make sure that the site conforms to: <ul style="list-style-type: none">• Loads on foundation, robot on page 43• Protection classes, robot on page 45• Requirements, foundation on page 44
9	Before moving the robot, please observe the stability of the robot: Risk of tipping/stability on page 50
10	When these prerequisites are met, the robot can be taken to its installation site as described in section: On-site installation on page 59
11	Install required equipment, if any. <ul style="list-style-type: none">• Safety lamp (option for IRC5) on page 89

2.2.2 Technical data

Weight, robot

The table shows the weight of the robot.

The weight does not include the weight of the DressPack.

Robot model	Weight
IRB 6700Inv / IRB 6700I	1,750 kg



Note

The weight does not include tools and other equipment fitted on the robot.
The weight does not include the weight of the DressPack.

Mounting positions

The table shows valid mounting options for the manipulator.

Mounting option	Installation angle	Note
Inverted	180°	

Loads on foundation, robot

The illustration shows the directions of the robots stress forces.

The directions are valid for all floor mounted, suspended and inverted robots.

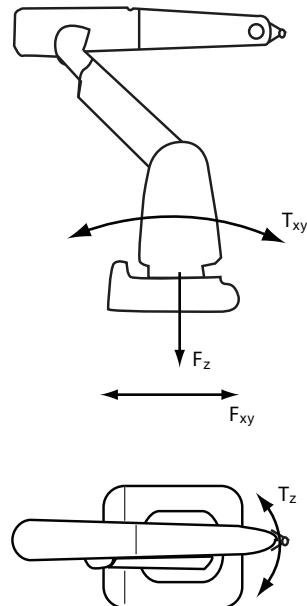

xx1100000521

F_{xy}	Force in any direction in the XY plane
F_z	Force in the Z plane
T_{xy}	Bending torque in any direction in the XY plane
T_z	Bending torque in the Z plane

Continues on next page

2 Installation and commissioning

2.2.2 Technical data

Continued

The table shows the various forces and torques working on the robot during different kinds of operation.



Note

These forces and torques are extreme values that are rarely encountered during operation. The values also never reach their maximum at the same time!



WARNING

The robot installation is restricted to the mounting options given in following load table(s).

Inverted

Force	Endurance load (in operation)	Max. load (emergency stop)
Force xy	±8.9 kN	±23.7 kN
Force z	-22.1 ±6.6 kN	-22.1 ± 18.1 kN
Torque xy	±22.5 kNm	±45.4 kNm
Torque z	±6.5 kNm	±15.7 kNm

Requirements, foundation

The table shows the requirements for the foundation where the weight of the installed robot is included:

Requirement	Value	Note
Flatness of foundation surface	0.3 mm	Flat foundations give better repeatability of the resolver calibration compared to original settings on delivery from ABB. The value for levelness aims at the circumstance of the anchoring points in the robot base.
Minimum resonance frequency	22 Hz Note It may affect the manipulator life-time to have a lower resonance frequency than recommended.	The value is recommended for optimal performance. Due to foundation stiffness, consider robot mass including equipment. ⁱ For information about compensating for foundation flexibility, see the application manual of the controller software, section <i>Motion Process Mode</i> .

ⁱ The minimum resonance frequency given should be interpreted as the frequency of the robot mass/inertia, robot assumed stiff, when a foundation translational/torsional elasticity is added, i.e., the stiffness of the pedestal where the robot is mounted. The minimum resonance frequency should not be interpreted as the resonance frequency of the building, floor etc. For example, if the equivalent mass of the floor is very high, it will not affect robot movement, even if the frequency is well below the stated frequency. The robot should be mounted as rigid as possible to the floor.

Disturbances from other machinery will affect the robot and the tool accuracy. The robot has resonance frequencies in the region 10 – 20 Hz and disturbances in this region will be amplified, although somewhat damped by the servo control. This might be a problem, depending on the requirements from the applications. If this is a problem, the robot needs to be isolated from the environment.

Continues on next page

Storage conditions, robot

The table shows the allowed storage conditions for the robot:

Parameter	Value
Minimum ambient temperature	-25 °C (-13 °F)
Maximum ambient temperature	+55 °C (+131 °F)
Maximum ambient temperature (less than 24 hrs)	+70 °C (+158 °F)
Maximum ambient humidity	Maximum 95% at constant temperature.

Operating conditions, robot

The table shows the allowed operating conditions for the robot:

Parameter	Value
Minimum ambient temperature	+5 °C ⁱ (41 °F)
Maximum ambient temperature	+50 °C (122 °F)
Maximum ambient humidity	Maximum 95% at constant temperature.

ⁱ At low environmental temperature (below 10 °C) a warm-up phase is recommended to be run with the robot. Otherwise there is a risk that the robot stops or runs with lower performance due to temperature dependent oil and grease viscosity.

Protection classes, robot

The table shows the available protection types of the robot, with the corresponding protection class.

Protection type	Protection class ⁱ
Manipulator, protection type Standard	IP67
Manipulator, protection type Foundry Plus	IP67

ⁱ According to IEC 60529.

2 Installation and commissioning

2.2.3 Working range

2.2.3 Working range

Working range

Axis	Type of motion	Working range	Note
Axis 1	Rotation motion	$\pm 170^\circ$	
Axis 2	Arm motion	$\pm 65^\circ$ ⁱ	
Axis 3	Arm motion	-180° ⁱ / $+70^\circ$ ⁱ	
Axis 4	Wrist motion	$\pm 300^\circ$	Default value.
Axis 5	Bend motion	$\pm 130^\circ$ ⁱⁱ	
Axis 6	Turn motion	$\pm 360^\circ$ ⁱⁱⁱ	Default value.
		± 93.7 revolutions	Maximum value. The default working range for axis 6 can be extended by changing parameter values in the software.

ⁱ Working ranges of axis 2 and axis 3 are limited in some areas to avoid collision with balancing. See [Working range axis 2 and axis 3 for IRB 6700Inv-300/2.60 and -245/2.90 on page 48](#).

ⁱⁱ Working range $+120^\circ$ to -120° for robots with option LeanID or LID variants.

ⁱⁱⁱ Working range $+220^\circ$ to -220° for robots with option LeanID or LID variants.

Illustration, working range IRB 6700Inv - 300/2.60

This illustration shows the unrestricted working range of the robot.

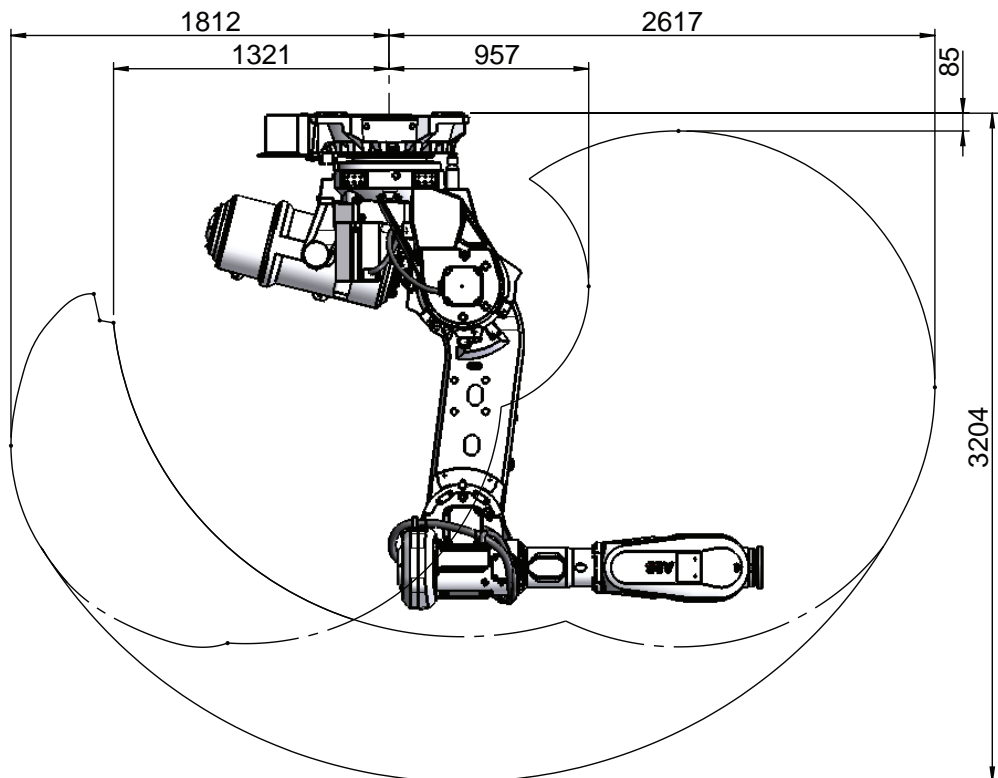

xx1700000573

Robot type	Handling capacity	Reach
IRB 6700Inv / IRB 6700I	300 kg	2.60 m

Continues on next page

Illustration, working range IRB 6700Inv - 245/2.90

This illustration shows the unrestricted working range of the robot.

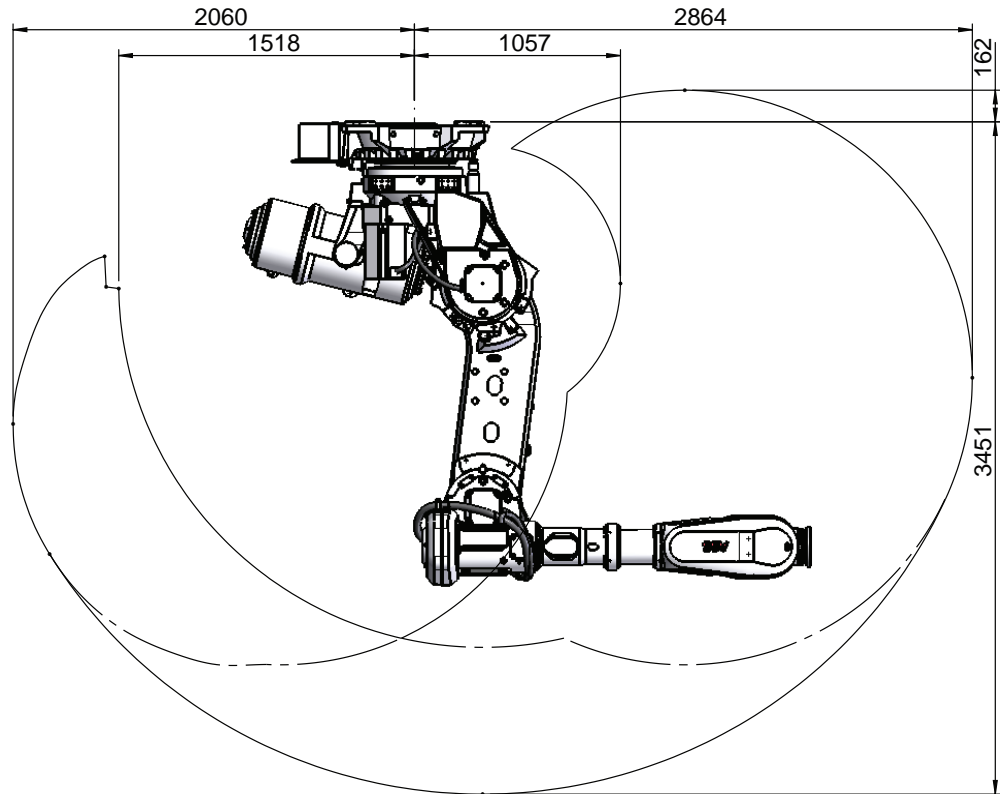

xx170000574

Robot type	Handling capacity	Reach
IRB 6700Inv / IRB 6700I	245 kg	2.90 m

Continues on next page

2 Installation and commissioning

2.2.3 Working range

Continued

Working range axis 2 and axis 3 for IRB 6700Inv-300/2.60 and -245/2.90

Limited in some areas to avoid collision with balancing.

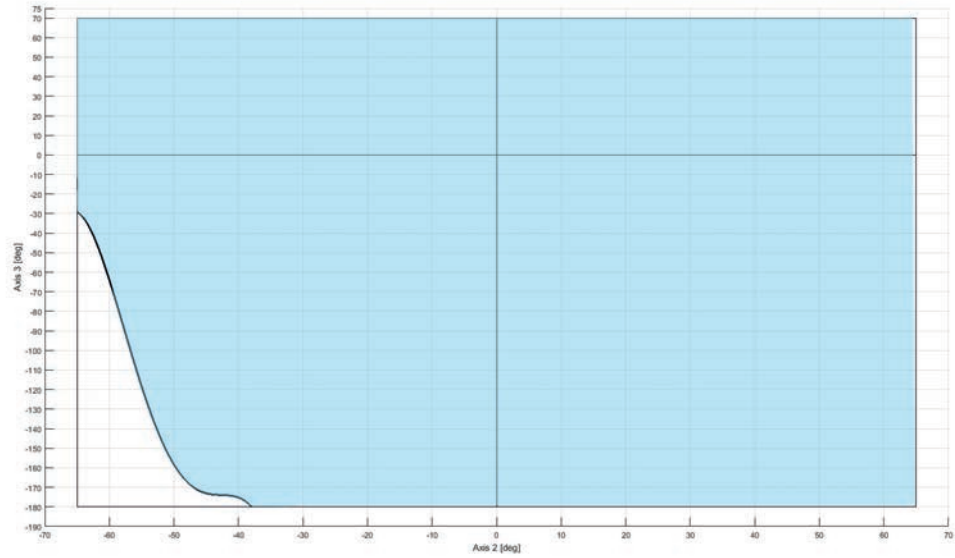

xx170000510

Continues on next page

Turning radius axis 1

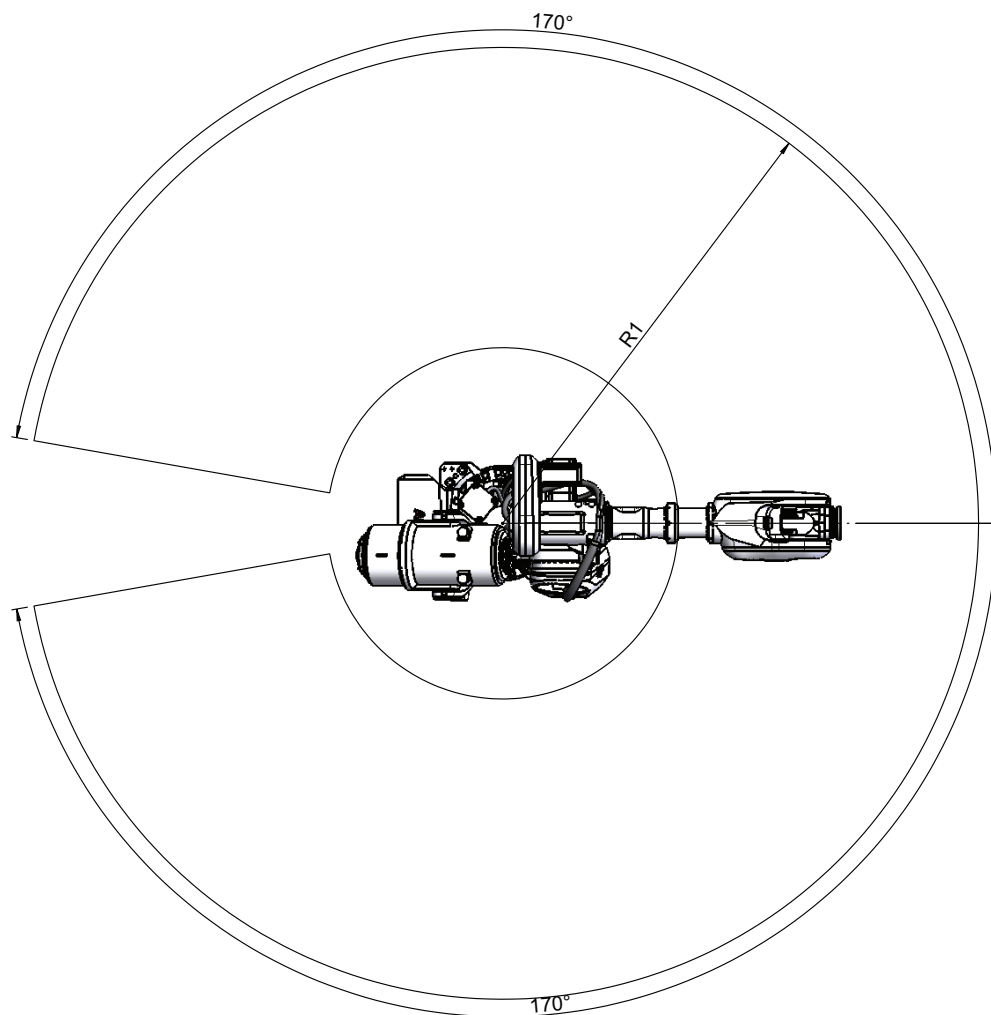

xx1700000575

Robot variant	R1 (mm)
IRB 6700Inv - 300/2.60	2617
IRB 6700Inv - 245/2.90	2864

2 Installation and commissioning

2.2.4 Risk of tipping/stability

2.2.4 Risk of tipping/stability

Risk of tipping

If the robot is not fastened to the foundation while moving the arm, the robot is not stable in the whole working area. Moving the arm will displace the center of gravity, which may cause the robot to tip over.

The transportation position is the most stable position.

Do not change the robot position before securing it to the foundation!

Transportation position

This figure shows the robot in its transportation position.

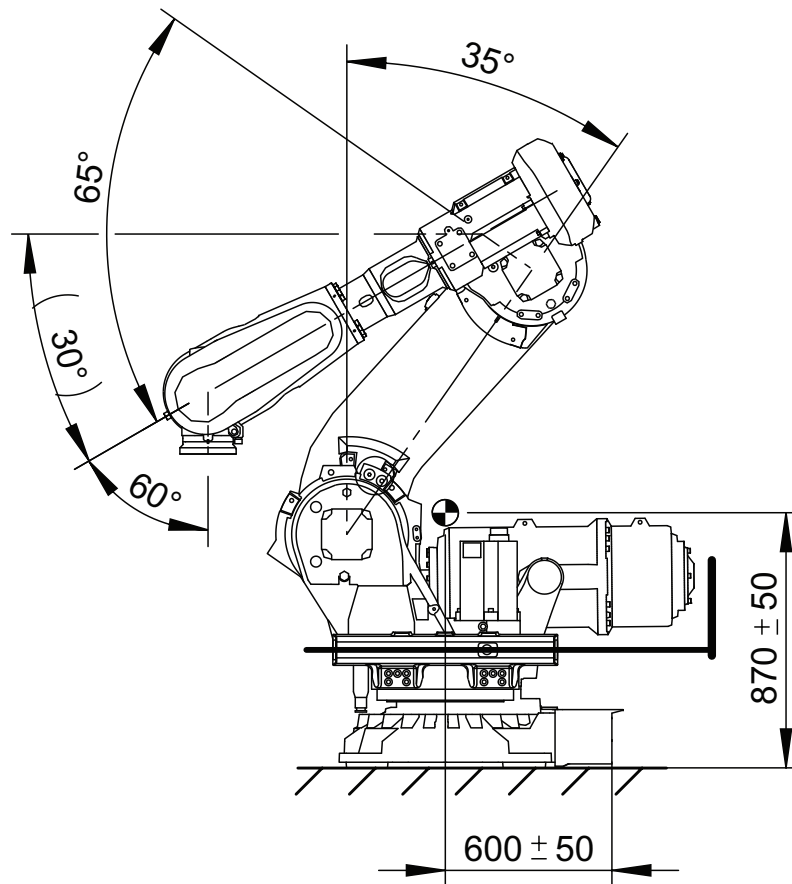

xx1600001371

Axis number	Angle of axis
Axis 1	0°
Axis 2	-35°
Axis 3	+65°
Axis 4	0°
Axis 5	+60°
Axis 6	0°

Continues on next page



Note

The robot might be positioned in a different position at delivery, due to actual configurations and options (for example DressPack).

Transportation lock screw

The robot arm system must always be locked in a secure position during lift, transport or rotation to inverted or standing position. This is done by locking the lower arm in position with a transportation lock screw.

At delivery, the robot and the lower arm is already locked in the correct position with the transportation lock screw.

How to use the transportation lock screw is described further in [Securing the robot arm position for lift, rotation and transportation on page 56](#).



DANGER

Always use the transportation lock screw and sleeve to lock the lower arm at transportation, turning and floor standing.



WARNING

The robot will be mechanically unstable if not properly secured to the foundation.

2 Installation and commissioning

2.2.5 Main dimensions

2.2.5 Main dimensions

Illustration

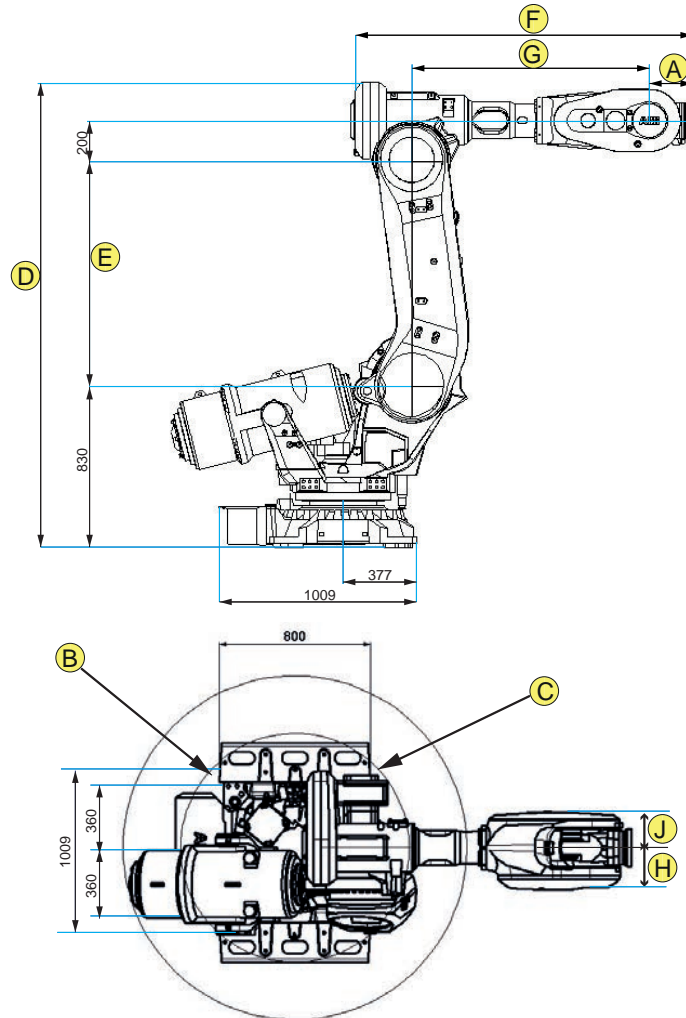

xx1700000559

Dimensions for different robot variants

Pos	Description
B	Radius ax1, front = 626 mm
C	Radius ax1, back = 910 mm

Robot variant	A	A LeanID (LID)	D	E	F	F LeanID (LID)	G	H	J
IRB 6700Inv - 300/2.60	220	380	2372	1145	1,718.5	1,878.5	1,212.5	222.5	187
IRB 6700I - 270/2.60 LID	N/A	380	2372	1145	N/A	1,878.5	1,212.5	222.5	187
IRB 6700Inv - 245/2.90	220	380	2372	1145	1,968.5	2,128.5	1,468.5	222.5	186

Continues on next page

2 Installation and commissioning

2.2.5 Main dimensions

Continued

Robot variant	A	A LeanID (LID)	D	E	F	F LeanID (LID)	G	H	J
IRB 6700I - 210/2.90 LID	N/A	380	2372	1145	N/A	2,128.5	1,468.5	222.5	186

2 Installation and commissioning

2.2.6 The unit is sensitive to ESD

2.2.6 The unit is sensitive to ESD

Description

ESD (electrostatic discharge) is the transfer of electrical static charge between two bodies at different potentials, either through direct contact or through an induced electrical field. When handling parts or their containers, personnel not grounded may potentially transfer high static charges. This discharge may destroy sensitive electronics.

Safe handling

Use one of the following alternatives:

- Use a wrist strap.

Wrist straps must be tested frequently to ensure that they are not damaged and are operating correctly.

- Use an ESD protective floor mat.

The mat must be grounded through a current-limiting resistor.

- Use a dissipative table mat.

The mat should provide a controlled discharge of static voltages and must be grounded.

2.3 On-site transportation

2.3.1 Robot transportation precautions

General

This section describes ABB approved transportation precautions for ABB robots.



CAUTION

All transportation in or outside the plant, must be carried out according to the method described in this section.

Transportation in any other way can seriously damage the robot. If the robot is incorrectly transported and the instructions are not followed, the robot is not covered by the warranty and ABB will not accept any compensation claim.

Method 1 - recommended method

Transportation according to method 1 is strongly recommended by ABB.

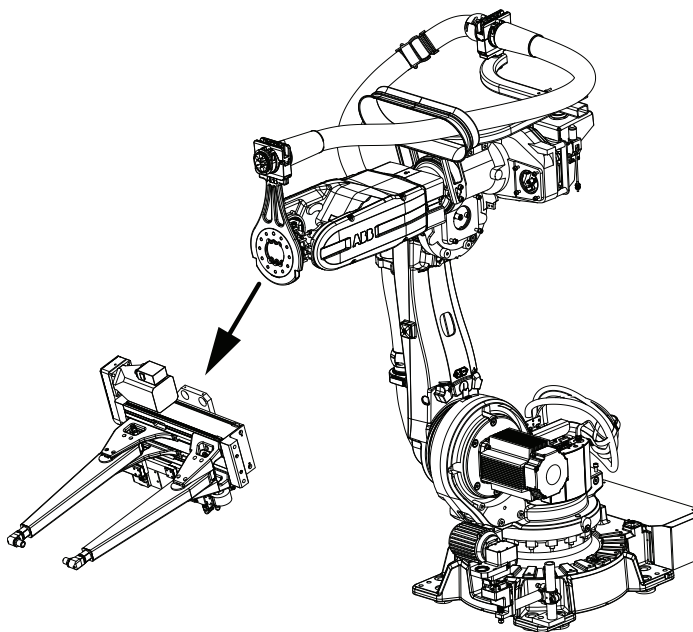

xx0800000030

Always follow these instructions when transporting an ABB robot according to method 1:

- Always remove the tool before transportation of the robot.
- Always place the robot in the ABB recommended transport position, described in section [Risk of tipping/stability on page 50](#).
- Always read and follow the instructions in section [Pre-installation procedure on page 42](#)
- Always use the transportation lock screw during lifting, turning and transporting of the robot, see [Securing the robot arm position for lift, rotation and transportation on page 56](#).

2 Installation and commissioning

2.3.2 Securing the robot arm position for lift, rotation and transportation

2.3.2 Securing the robot arm position for lift, rotation and transportation

Position of the lower arm must be secured

Lift, transport and rotation of the robot

The robot arm system must always be locked in a secure position during lift, transport or rotation to inverted or standing position. This is done by locking the lower arm in position with a transportation lock screw. The transportation lock screw is stored at a parking position in the robot frame, when not used. This section describes how to move the screw to the locking position in order to secure the lower arm.

At delivery, the robot and the lower arm is already locked in the correct position with the transportation lock screw.





CAUTION

No tool is permitted to be fitted on the robot when it is lifted, transported or rotated.

Temporarily floor standing of the robot

Always keep the the transportation lock screw and sleeve in locked position when the robot is floor standing. During some repair activities, the transportation lock screw and sleeve is replaced with service stops. These situations are clearly stated in the current repair activities in this manual. The service stops are detailed further in [Service stops on page 195](#).

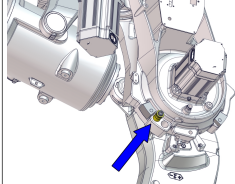
Required equipment

Equipment	Article number	Note	Figure
Transportation lock screw	3HAC059728-001 Sleeve 3HAB3409-93 Screw, M16x120 (class 12.9 or 8.8)	Used to secure the lower arm. Stored at the parking position on the robot frame.  xx1600002008	 xx1600002009

Continues on next page

Securing the lower arm

Use this procedure to secure the lower arm in order to prevent it from moving if the point of gravity is shifted in the mechanical structure of the robot during lifting, transporting or rotation of the robot.

Preparations before securing the lower arm

	Action	Note
1	<p>Remove any tools fitted on the axis-6 turning disc of the robot.</p> <p> CAUTION</p> <p>No tool is permitted to be fitted on the robot when it is lifted, transported or rotated.</p>	

Securing the lower arm

Use this procedure to secure the lower arm.

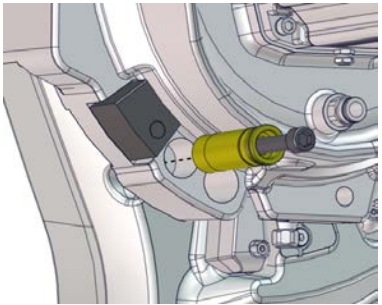
	Action	Note
1	<p>Jog axis 2 to -35°.</p> <p>If lifting, rotating or transporting the robot, all axes have to be jogged to defined angles:</p> <ul style="list-style-type: none"> • Axis 1: 0° • Axis 2: -35° • Axis 3: $+65^{\circ}$ • Axis 4: 0° • Axis 5: $+60^{\circ}$ • Axis 6: no significance 	
2	<p>Remove the transportation lock screw and the yellow sleeve from the parking position.</p>	 <p>xx1700000270</p>

Continues on next page

2 Installation and commissioning

2.3.2 Securing the robot arm position for lift, rotation and transportation

Continued

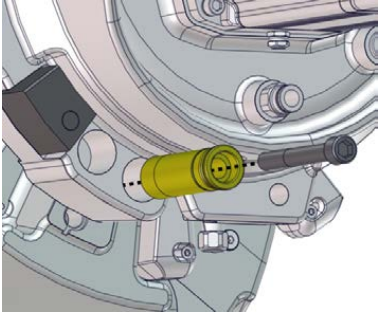
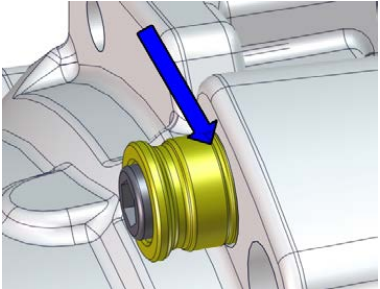
	Action	Note
3	<p>Insert the yellow sleeve and the transportation lock screw in the hole at the locking position. Insert the sleeve all the way so that the marking in the sleeve is aligned with the casting, see figure. Tighten the screw.</p> <p> DANGER</p> <p>Always use the transportation lock screw and sleeve to lock the lower arm at transportation, turning and floor standing.</p>	<p>Tightening torque: 70 Nm \pm15 Nm.</p>  <p>xx170000269</p>  <p>xx1600002114</p>

Storing the transportation lock screw when not in use

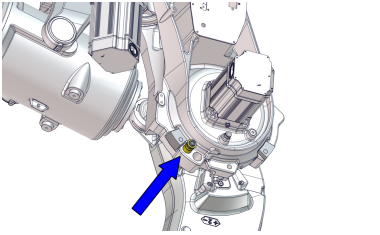
	Action	Note
1	<p>Keep the transportation lock screw stored in the parking position when not in use.</p>	 <p>xx1600002008</p>

2.4 On-site installation

2.4.1 Brief installation procedure

Introduction

This procedure is a brief guide when installing the robot for the first time. Also see [Pre-installation procedure on page 42](#).

First installation

Use these procedures to install the IRB 6700Inv / IRB 6700I.

	Action	Note
1	Transport the manipulator to its intended location.	
2	Install the valid platform or prepare the foundation for the manipulator.	
3	Lift and secure the manipulator to the platform/foundation.	See Lifting the robot on page 60 . See Orienting, rotating and securing the robot on page 66 .
4	Connect the manipulator to the controller.	See <ul style="list-style-type: none"> • <i>Product manual - IRC5</i> • <i>Product manual - IRC5 Panel Mounted Controller</i> • <i>Product manual - OmniCore V250XT</i> • <i>Product manual - OmniCore V250XT Type A</i>
5	Configure the safety settings.	See <ul style="list-style-type: none"> • <i>Product manual - IRC5</i> • <i>Product manual - IRC5 Panel Mounted Controller</i> • <i>Product manual - OmniCore V250XT</i> • <i>Product manual - OmniCore V250XT Type A</i>
6	How to start and run the robot is described in the product manual for the controller.	See <ul style="list-style-type: none"> • <i>Product manual - IRC5</i> • <i>Product manual - IRC5 Panel Mounted Controller</i> • <i>Product manual - OmniCore V250XT</i> • <i>Product manual - OmniCore V250XT Type A</i>
7	Install required equipment, if any. <ul style="list-style-type: none"> • Safety lamp (option for IRC5) on page 89 	
8	 DANGER Make sure all safety requirements are met when performing the first test run. See Test run after installation, maintenance, or repair on page 97 .	

2 Installation and commissioning

2.4.2.1 Lifting the robot with fork lift

2.4.2 Lifting the robot

2.4.2.1 Lifting the robot with fork lift

Lifting methods

The robot may be lifted and transported using a fork lift, provided that available special aids are used.

For rotation of the robot to an inverted position, the fork lift accessory must be used together with a special turning tool or a fork lift truck with a rotator attachment.

This section specifies available special aids and references to valid user documentation for the lifting accessories.

Also follow the recommendations given in [Robot transportation precautions on page 55](#).

Required tools and equipment

Equipment	Article number	Note
Fork lift accessory set	3HAC058825-001	Contains fork lift pockets and all required hardware for installation. User instructions are enclosed with the tool, see Directions for use - Fork lift accessory 3HAC058825-001. In order to rotate the robot, either use the turning tool or a fork lift truck with a rotator attachment.
Turning tool	3HAC073537-001	Lift and rotation of inverted robot. Requires fork lift accessory set 3HAC058825-001. User instructions are enclosed with the tool.

Required documents

Document	Document number
Directions for use - Fork lift accessory 3HAC058825-001	3HAC060303-001
Directions for use - Lifting and rotating accessory for IRB 6700Inv/IRB6700I	3HAC073537-003

Lifting the robot

	Action	Note
1	Lift the robot according to the user instructions enclosed with the fork lift accessory.	

2.4.2.2 Lifting and rotating a suspended mounted or tilted manipulator

Introduction

How to lift and turn the robot to a suspended/inverted position using the turning accessory is described in the lifting instruction delivered with the turning accessory. Article numbers for the accessory and the instruction is specified in [Special tools on page 725](#). Any additional equipment required is specified in the instruction for the lifting accessory. Contact ABB for more information.

Illustration



xx2100002608

2 Installation and commissioning

2.4.2.3 Lifting the robot with roundslings

2.4.2.3 Lifting the robot with roundslings

Roundslings used for lifting and transporting

The robot can be lifted and transported using roundslings according to this section.

For rotation of the robot to an inverted position, a fork lift accessory must be used together with a special turning tool or a fork lift truck with a rotator attachment.

See [Lifting the robot with fork lift on page 60](#).

Attaching the roundslings

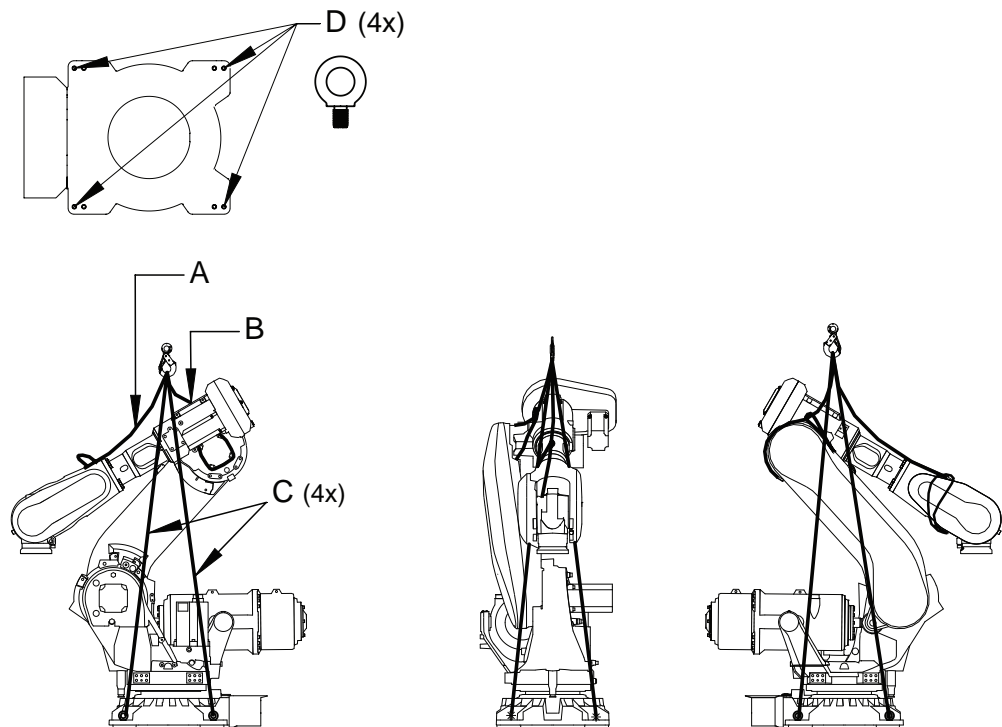

xx1600001372

Variant	Length A (1 pc) Do not strain!	Length B (1 pc) Do not strain!
IRB 6700Inv - 300/2.60	Roundslings, 2.5 m	Roundslings, 2.5 m
IRB 6700I - 270/2.60 LID	Roundslings, 2.5 m	Roundslings, 2.5 m
IRB 6700Inv - 245/2.90	Roundslings, 2.5 m	Roundslings, 2.5 m
IRB 6700I - 210/2.90 LID	Roundslings, 2.5 m	Roundslings, 2.5 m
C	Roundslings, 2.5 m (4 pcs)	
D	Lifting eye, M20 (4 pcs)	

Required equipment

See quantity of roundslings in figure [Attaching the roundslings on page 62](#).

Equipment, etc.	Article number	Note
Overhead crane	-	

Continues on next page

2 Installation and commissioning

2.4.2.3 Lifting the robot with roundslings

Continued

Equipment, etc.	Article number	Note
Lifting eye, M20	-	Working load limit: 2,000 kg.
Roundslings, 2.5 m	-	Lifting capacity: 2,000 kg.

Lifting the robot with roundslings

Use this procedure to lift the robot with roundslings.

Lifting the robot with roundslings

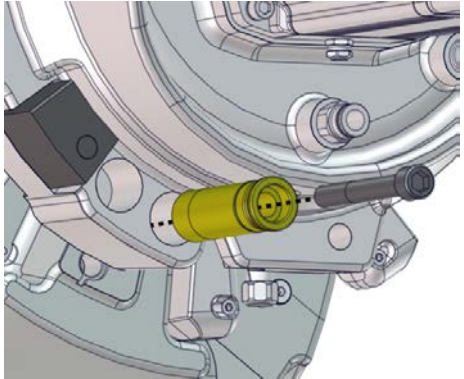
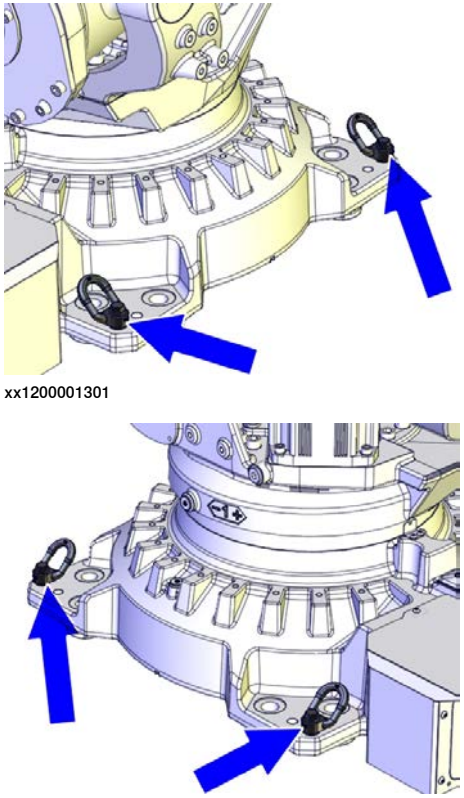





	Action	Note
1	Verify that the lower arm is secured with the transportation lock screw in the locking position.	<p>Tightening torque: 70 Nm \pm15 Nm.</p>  <p>xx1700000269</p> <p>See Securing the robot arm position for lift, rotation and transportation on page 56.</p>
2	Fit lifting eyes to the outer holes on each corner of the base.	 <p>xx1200001301</p> <p>xx1200001302</p>

Continues on next page

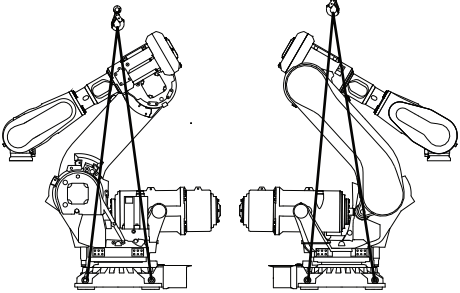
2 Installation and commissioning

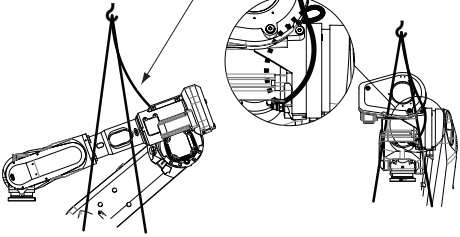
2.4.2.3 Lifting the robot with roundslings

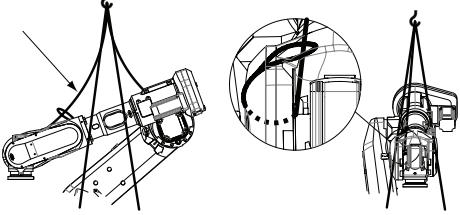
Continued

	Action	Note
3	<p>Run roundslings through the lifting eyes and fasten them in an overhead crane.</p> <p> CAUTION</p> <p>If the lifting eyes have sharp edges that might damage the roundslings, lifting shackles must be used to attach the roundslings to the lifting eyes.</p>	<p>Make sure the roundslings do not rub against any sharp edges.</p> <p>Roundsling, 2.5 m (4 pcs)</p>  <p>xx1600001374</p>
4	<p>Attach a securing roundsling at the rear according to figure.</p> <p> Note</p> <p>The securing sling must not be strained at lifting. It only secures for tipping.</p>	<p>Length for the roundsling is given in the table Attaching the roundslings on page 62.</p>  <p>xx1300001573</p>
5	<p>Attach a securing roundsling at the front according to figure.</p> <p> Note</p> <p>The securing sling must not be strained at lifting. It only secures for tipping.</p>	<p>Length for the roundsling is given in the table Attaching the roundslings on page 62.</p>  <p>xx1300001574</p>
6	<p> CAUTION</p> <p>The IRB 6700Inv / IRB 6700I robot weighs 1,750 kg.</p> <p>All lifting accessories used must be sized accordingly!</p>	
7	<p> WARNING</p> <p>Personnel must not, under any circumstances, be present under the suspended load!</p>	

Continues on next page

	Action	Note
8	<p>Raise the overhead crane to lift the robot.</p> <p> CAUTION</p> <p>Make sure that the roundslings running from the front, left corner is positioned on the correct side of the brake release unit plate when stretching the roundslings with the crane.</p>	

2 Installation and commissioning

2.4.3 Orienting, rotating and securing the robot

2.4.3 Orienting, rotating and securing the robot

General

This section details how to orient and secure the robot to the installation site in order to run the robot safely.

Hole configuration, base

The figure shows the hole configuration used when positioning and securing the robot.

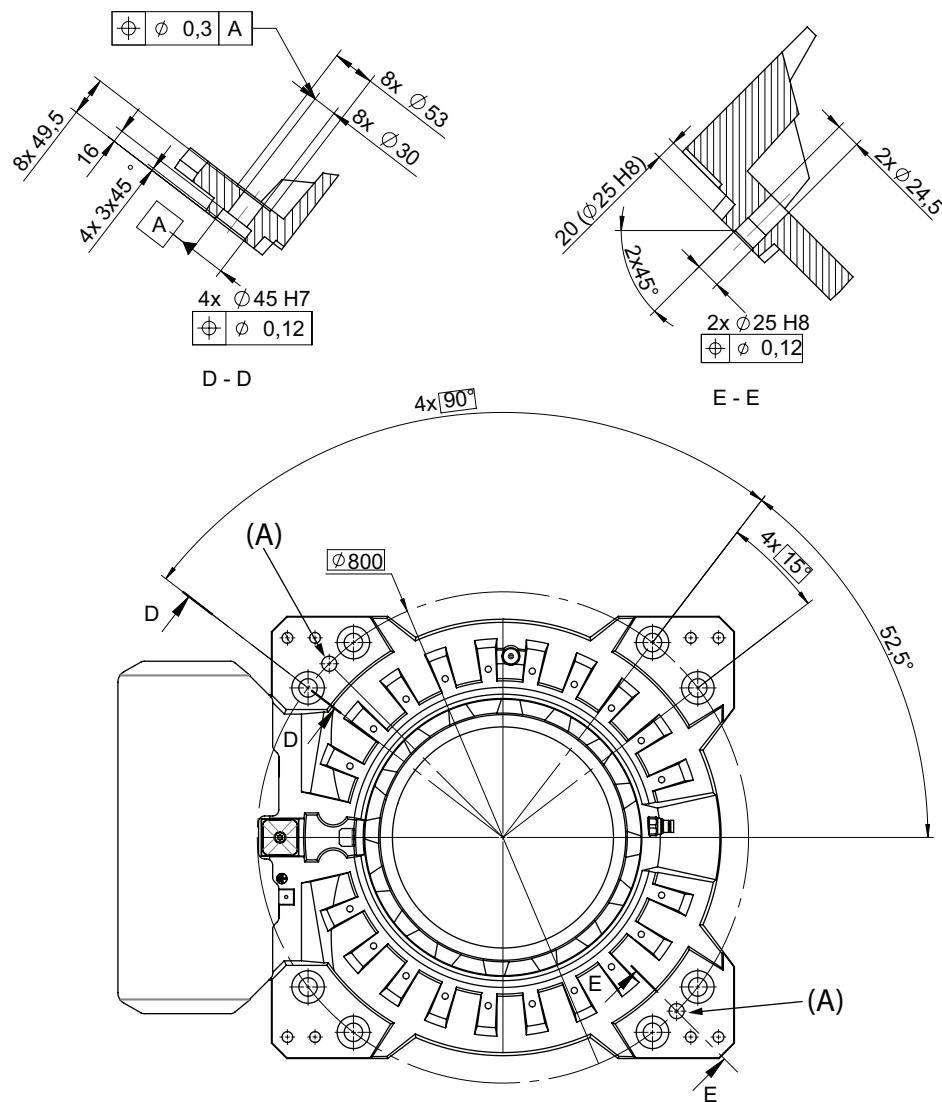

xx1300000243

Pos	Description
A	Holes for guide pins (x2)

Continues on next page

2 Installation and commissioning

2.4.3 Orienting, rotating and securing the robot

Continued

Attachment screws

The table below specifies the type of securing screws and washers to be used for securing the robot to the foundation.

Suitable screws, lightly lubricated	M24x100
Quantity	8 pcs
Quality	8.8
Screw tightening yield point utilization factor (v) (according to VDI2230)	90% (v=0.9)
Suitable washer	4 mm flat washer
Tightening torque	550 Nm (screws lubricated with Molykote 1000) 600-725 Nm, typical 650 Nm (screws none or lightly lubricated)

Required tools and equipment

Equipment	Article number	Note
Fork lift accessory set	3HAC058825-001	Contains fork lift pockets and all required hardware for installation. User instructions are enclosed with the tool, see Directions for use - Fork lift accessory 3HAC058825-001. In order to rotate the robot, either use the turning tool or a fork lift truck with a rotator attachment.
Turning tool	3HAC073537-001	Lift and rotation of inverted robot. Requires fork lift accessory set 3HAC058825-001. User instructions are enclosed with the tool.

Required documents

Document	Document number
Directions for use - Fork lift accessory 3HAC058825-001	3HAC060303-001
Directions for use - Lifting and rotating accessory for IRB 6700Inv/IRB6700I	3HAC073537-003

Securing the robot

Use this procedure to secure the robot to the foundation.

Preparations of the installation site

	Action	Note
1	Make sure the foundation conforms to all requirements stated in Pre-installation procedure on page 42 .	
2	Prepare the installation site. The foundation surface must be clean and unpainted.	See Hole configuration, base on page 66 and Attachment screws on page 67 .

Continues on next page



2 Installation and commissioning

2.4.3 Orienting, rotating and securing the robot

Continued

Securing the lower arm

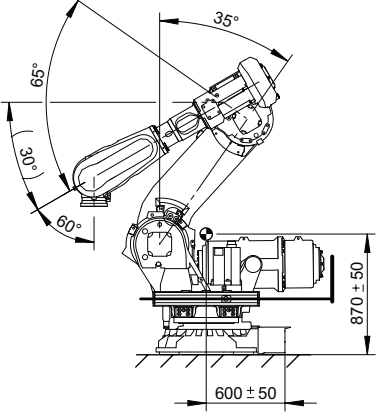
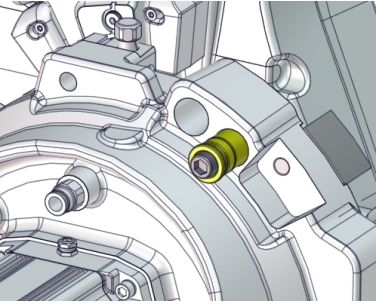
Use this procedure to secure the lower arm before lifting the robot to inverted position.

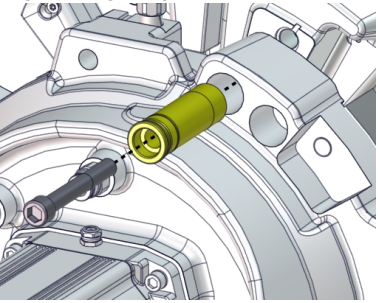
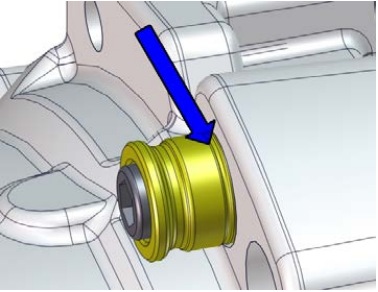
	Action	Note
1	Verify that the robot stands in position: <ul style="list-style-type: none"> • Axis 1: 0° • Axis 2: -35° • Axis 3: +65° • Axis 4: 0° • Axis 5: +60° • Axis 6: no significance 	 <p>xx1600001371</p>
2	Remove the transportation lock screw and the yellow sleeve from the parking position.	 <p>xx1700000348</p>
3	Insert the yellow sleeve and the transportation lock screw in the hole at the locking position. Insert the sleeve all the way so that the marking in the sleeve is aligned with the casting, see figure. Tighten the screw.  DANGER Always use the transportation lock screw and sleeve to lock the lower arm at transportation, turning and floor standing.	<p>Tightening torque: 70 Nm ±15 Nm.</p>  <p>xx1700000347</p>  <p>xx1600002114</p>



Continues on next page

2 Installation and commissioning

2.4.3 Orienting, rotating and securing the robot

Continued

Orienting and securing the robot

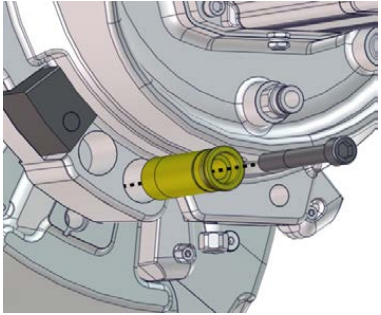
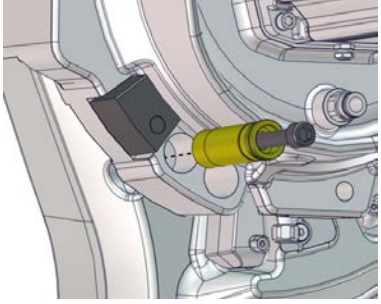
	Action	Note
1	Lift the robot using the fork lift accessory.	See user instructions enclosed with the fork lift accessory.
2	Move the robot close to its installation location.	
3	Rotate the robot into inverted position using the turning tool or using a fork lift truck with a rotator attachment.  DANGER Make sure that there is enough space underneath the robot. See user instructions for the turning tool.	See user instructions enclosed with the turning tool.
4	Guide the robot using two M24 screws while lifting it into its mounting position.	
5	Fit the bolts and washers in the base attachment holes.  Note Lightly lubricate screws before assembly.  CAUTION If high stress on screws are suspected, replace used screws with new ones.	Suitable screws, lightly lubricated: M24x100 (8 pcs), 8.8. Suitable washer: 4 mm flat washer. Screw tightening yield point utilization factor (v) (according to VDI2230): 90% (v=0.9). Tightening torque: 550 Nm (screws lubricated with Molykote 1000) 600-725 Nm, typical 650 Nm (screws none or lightly lubricated)
6	Tighten bolts in a crosswise pattern to ensure that the base is not distorted.	
7	Remove the yellow sleeve and transportation lock screw from the transportation and turning position.	 xx1700000269
8	Fasten the yellow sleeve and transportation lock screw in its parking position.	Tightening torque: 70 Nm ±15 Nm.  xx1700000270

2 Installation and commissioning

2.4.4 Manually releasing the brakes

2.4.4 Manually releasing the brakes

Introduction to manually releasing the brakes

This section describes how to release the holding brakes for the motors of each axis.

Location of brake release unit

The internal brake release unit is located as shown in the figure.

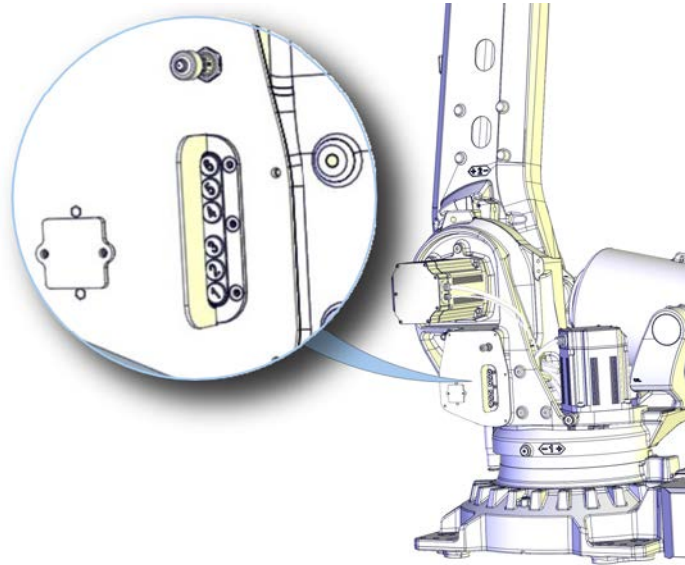

xx120000964

Releasing the brakes

This procedure details how to release the holding brakes when the robot is equipped with an internal brake release unit.

	Action	Note
1	<p>The internal brake release unit is equipped with buttons for controlling the axes brakes. The buttons are numbered according to the numbers of the axes.</p> <p>If the robot is not connected to the controller, power must be supplied to the connector R1.MP according to the section Supplying power to connector R1.MP on page 71.</p>	<p>Buttons are shown in figure Location of brake release unit on page 70.</p>

Continues on next page

2 Installation and commissioning

2.4.4 Manually releasing the brakes

Continued

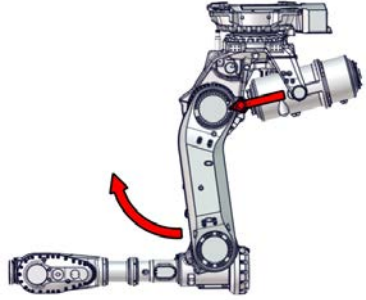
	Action	Note
2	<p> DANGER</p> <p>When releasing the holding brakes, the robot axes may move very quickly and sometimes in unexpected ways.</p> <p>Release of the axis-2 motor holding brakes can cause the axis 2 to move in opposite direction in regard to gravity, due to the pushing force from the balancing device. Current arm load and position of the lower and upper arm determines the occurring movement when releasing the holding brakes of the axis-2 motor.</p> <p>Make sure no personnel is near or beneath the robot.</p>	<p>In the example below, with no arm load and in synchronization position, the pushing force from the balancing device will cause the lower and upper arm to move forwards/upwards, when the brakes of the axis-2 motor are released.</p>  <p>xx1700000522</p>
3	<p>Release the holding brake on a particular robot axis by pressing the corresponding button on the internal brake release unit.</p> <p>The brake will function again as soon as the button is released.</p>	

Supplying power to connector R1.MP

If the robot is not connected to the controller, power must be supplied to connector R1.MP on the robot, in order to enable the brake release buttons.

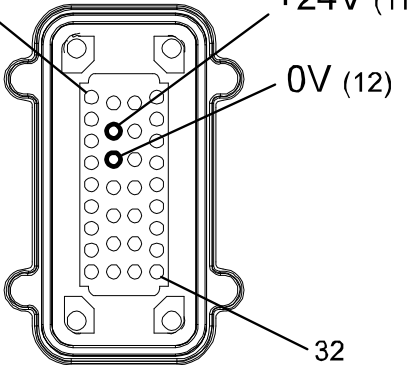
	Action	Note
1	<p> DANGER</p> <p>Incorrect connections, such as supplying power to the wrong pin, may cause all brakes to be released simultaneously!</p>	
2	<p>Supply 0V on pin 12 and 24V on pin 11.</p>	<p></p> <p>xx0600002937</p>

2 Installation and commissioning

2.4.5 Loads fitted to the robot, stopping time and braking distances

2.4.5 Loads fitted to the robot, stopping time and braking distances

General

Any loads mounted on the robot must be defined correctly and carefully (with regard to the position of center of gravity and mass moments of inertia) in order to avoid jolting movements and overloading motors, gears and structure.



CAUTION

Incorrectly defined loads may result in operational stops or major damage to the robot.

References

Load diagrams, permitted extra loads (equipment) and their positions are specified in the product specification. The loads must be defined in the software.

- *Operating manual - IRC5 with FlexPendant*
- *Operating manual - OmniCore*

Stopping time and braking distances

The performance of the motor brake depends on if there are any loads attached to the robot. For more information, see product specification listed in [References on page 10](#).

2.4.6 Fitting equipment to the robot

General

Extra loads can be fitted on the upper arm housing, the lower arm, and on the frame. Definitions of distances and masses are shown in the following figures. The robot is supplied with holes for fitting extra equipment (see figure in [Holes for fitting extra equipment on page 76](#)). Maximum allowed arm load depends on center of gravity of arm load and robot payload.



Note

All equipment and cables used on the robot, must be designed and fitted not to damage the robot and/or its parts.

Frame (hip load)

Extra load can be fitted on the frame.

	Description
Permitted extra load on frame	$J_H = 100 \text{ kgm}^2$
Recommended position (see the following figure)	$J_H = J_{H0} + M4 \times R^2$ where: <ul style="list-style-type: none"> • J_{H0} is the moment of inertia of the equipment • R is the radius (m) from the center of axis 1 • $M4$ is the total mass (kg) of the equipment including bracket and harness ($\leq 250 \text{ kg}$)

Continues on next page

2 Installation and commissioning

2.4.6 Fitting equipment to the robot

Continued

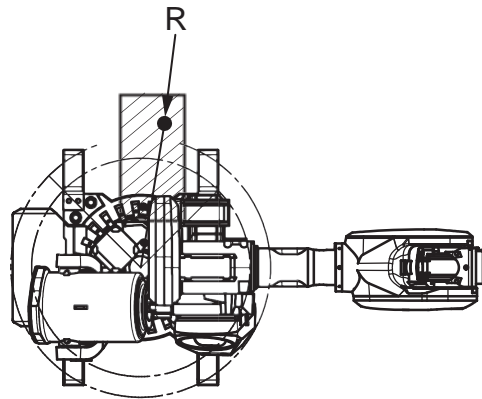
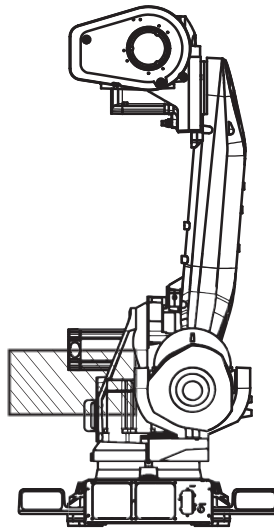

xx130000262

Upper arm

Allowed extra load on the upper arm housing, in addition to the maximum handling weight, is $M1 \leq 50 \text{ kg}$ with a distance (a) $\leq 500 \text{ mm}$ from the center of gravity in the axis-3 extension.

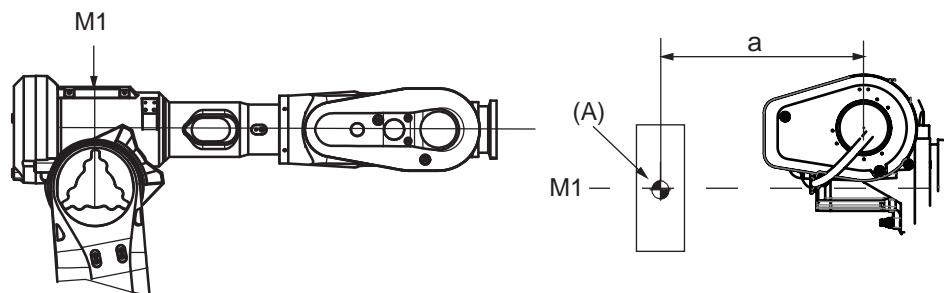

xx1400002019

A	Mass center
---	-------------

Continues on next page

2 Installation and commissioning

2.4.6 Fitting equipment to the robot

Continued

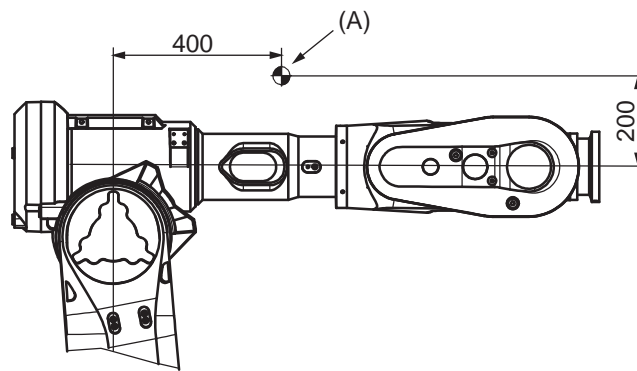

xx130000866

A	Center of gravity 50 kg
---	-------------------------

Continues on next page

2 Installation and commissioning

2.4.6 Fitting equipment to the robot

Continued

Holes for fitting extra equipment

The holes are placed the same regardless of the controller. To simplify reading the tables, the variants are presented first for IRC5, then for OmniCore.

Position of attachment holes - drawing 1, IRC5

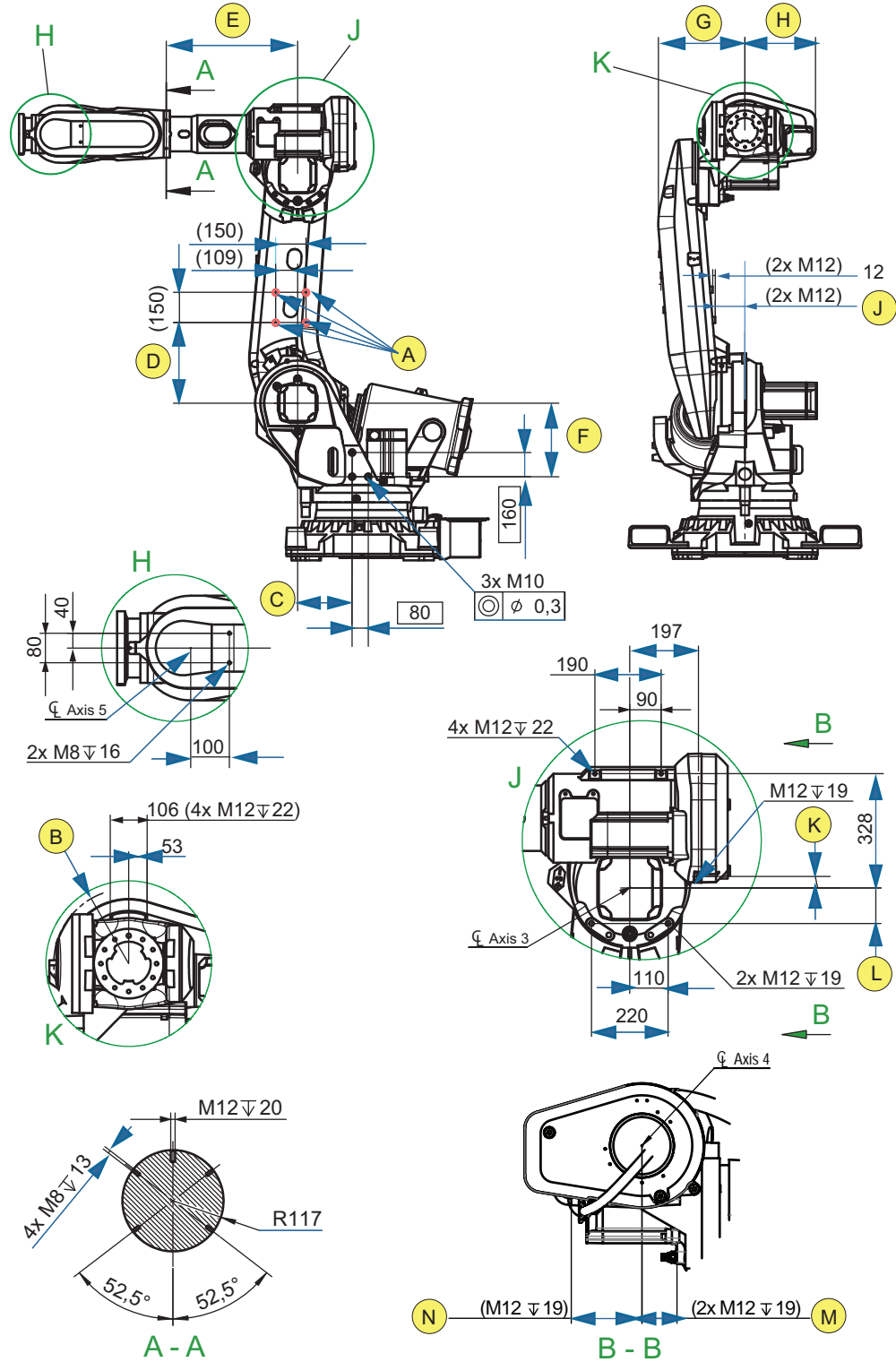

xx1300000263

Continues on next page

2 Installation and commissioning

2.4.6 Fitting equipment to the robot

Continued

A	Allowed position for attachment holes, M12 through. Be careful not to touch the cables when drilling.
---	---

Variant	B ⁱ	C	D	E	F	G	H	J	K	L	M	N
IRB 6700Inv - 300/2.60	R=230	310	450	652.5	376	467	405	152	12	117	98.5	215.5
IRB 6700Inv - 245/2.90	R=230	310	450	652.5	376	467	405	152	12	117	98.5	215.5

ⁱ Smallest circumscribed radius axis-4.

Position of attachment holes - drawing 2, IRC5

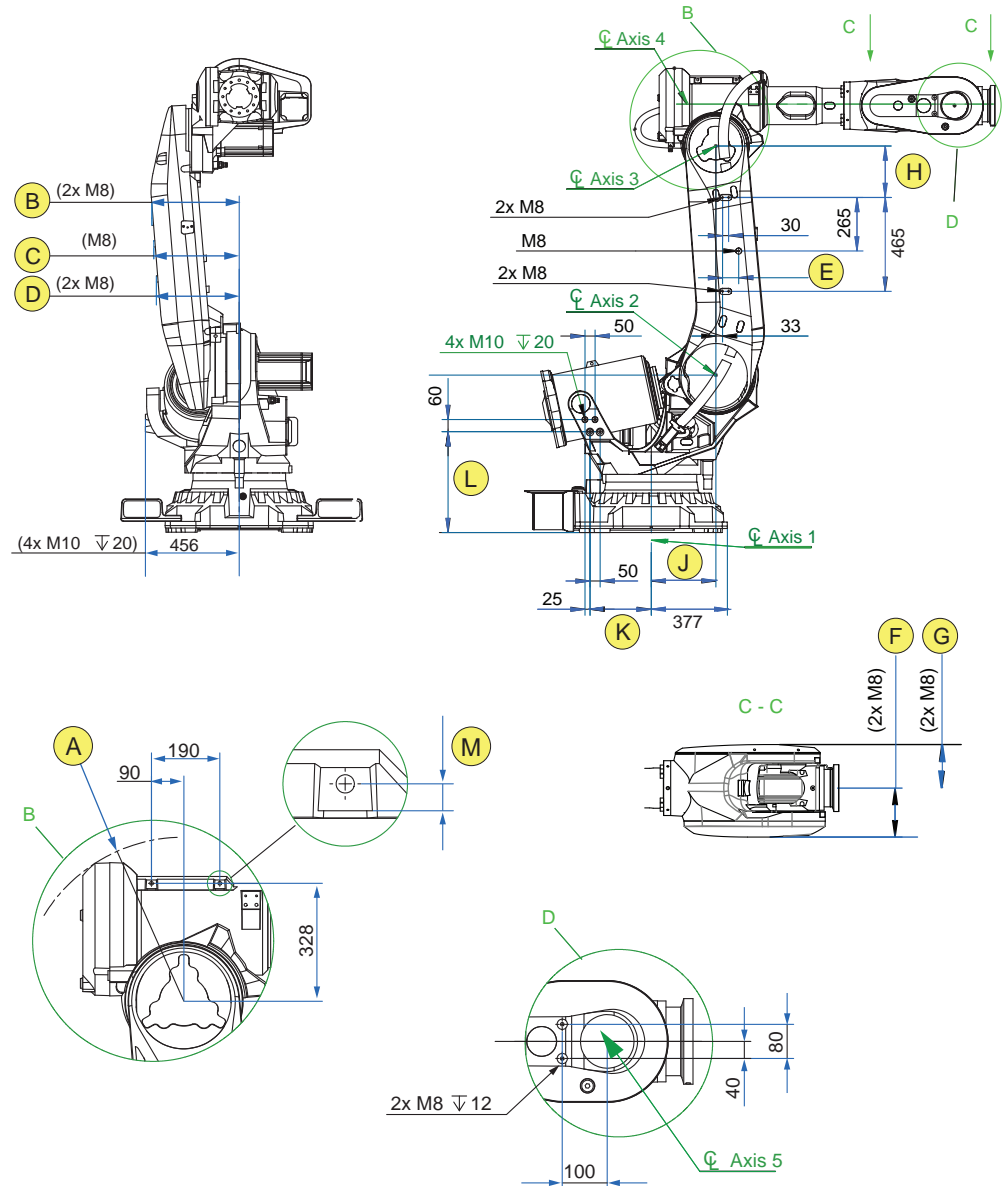

xx130000264

Variant	A ⁱ	B	C	D	E	F	G	H	J	K	L	M
IRB 6700Inv - 300/2.60	R=468	453	438	423	80	222.5	187	265	350	273.5	523.5	15
IRB 6700Inv - 245/2.90	R=468	453	438	423	80	222.5	187	265	350	273.5	523.5	15

ⁱ Smallest circumscribed radius axis-3.

Continues on next page

2 Installation and commissioning

2.4.6 Fitting equipment to the robot

Continued

Position of attachment holes - drawing 1, OmniCore

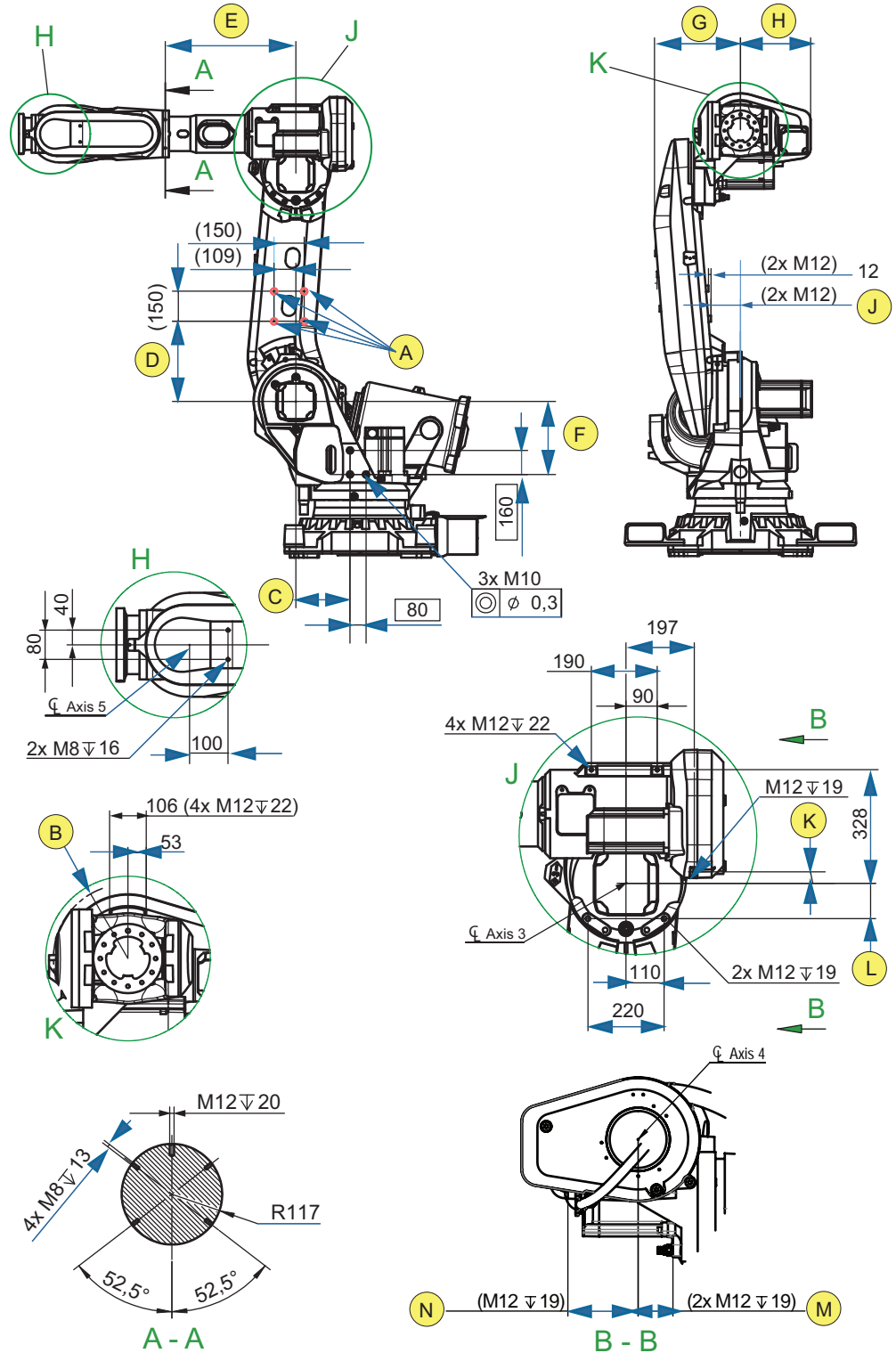

xx1300000263

A	Allowed position for attachment holes, M12 through. Be careful not to touch the cables when drilling.
---	---

Continues on next page

2 Installation and commissioning

2.4.6 Fitting equipment to the robot

Continued

Variant	B ⁱ	C	D	E	F	G	H	J	K	L	M	N
IRB 6700Inv - 300/2.60	R=230	310	450	652.5	376	467	405	152	12	117	98.5	215.5
IRB 6700Inv - 245/2.90	R=230	310	450	652.5	376	467	405	152	12	117	98.5	215.5

ⁱ Smallest circumscribed radius axis-4.

Position of attachment holes - drawing 2, OmniCore

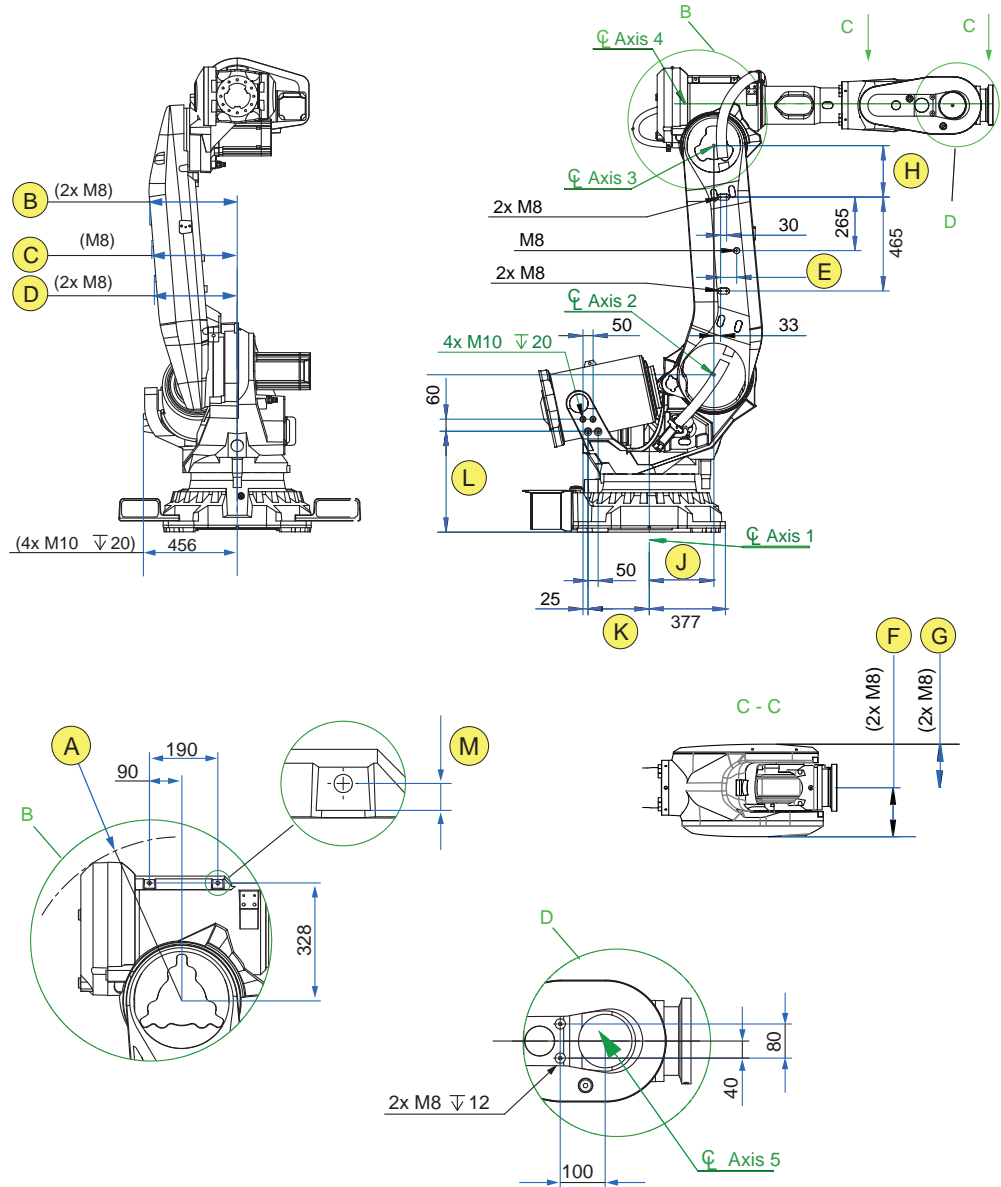

xx130000264

Variant	A ⁱ	B	C	D	E	F	G	H	J	K	L	M
IRB 6700Inv - 300/2.60	R=468	453	438	423	80	222.5	187	265	350	273.5	523.5	15
IRB 6700Inv - 245/2.90	R=468	453	438	423	80	222.5	187	265	350	273.5	523.5	15

ⁱ Smallest circumscribed radius axis-3.

Continues on next page

2 Installation and commissioning

2.4.6 Fitting equipment to the robot

Continued

Extra cover

There is an extra cover for LeanID variants (upper arm cover). So that value A for LeanID variants is different.

There is an extra cover for LID variants (upper arm cover). So that value A for LID variants is different.

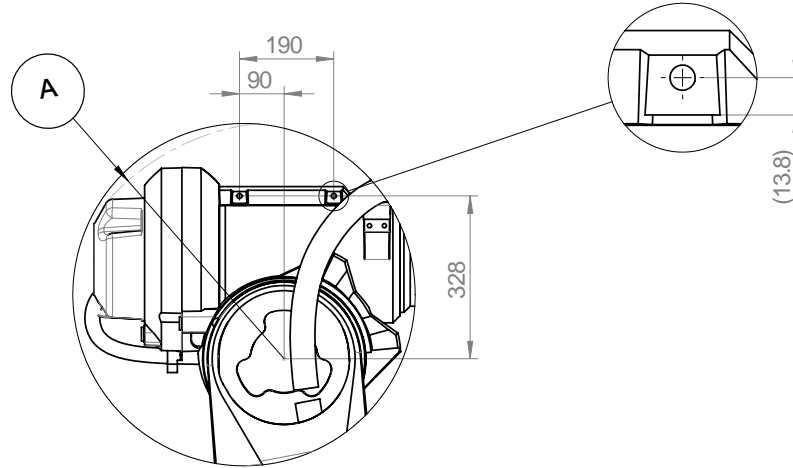

xx2100002054

Tool flange, standard

Below is the standard tool flange. The guide pin hole is, in calibration position, pointing upwards in Z-direction.

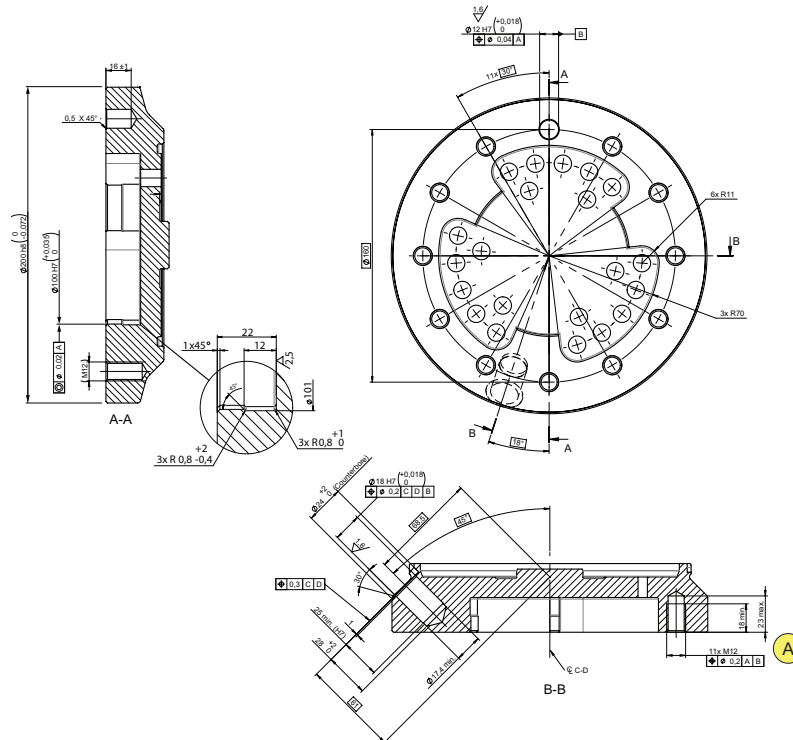

xx1300000280

A	Thread length: 18 mm.
---	-----------------------

Continues on next page

Tool flange, LeanID, LID variants

Below is the tool flange for option/variant LeanID (LID). The guide pin hole is, in calibration position, pointing upwards in Z-direction.

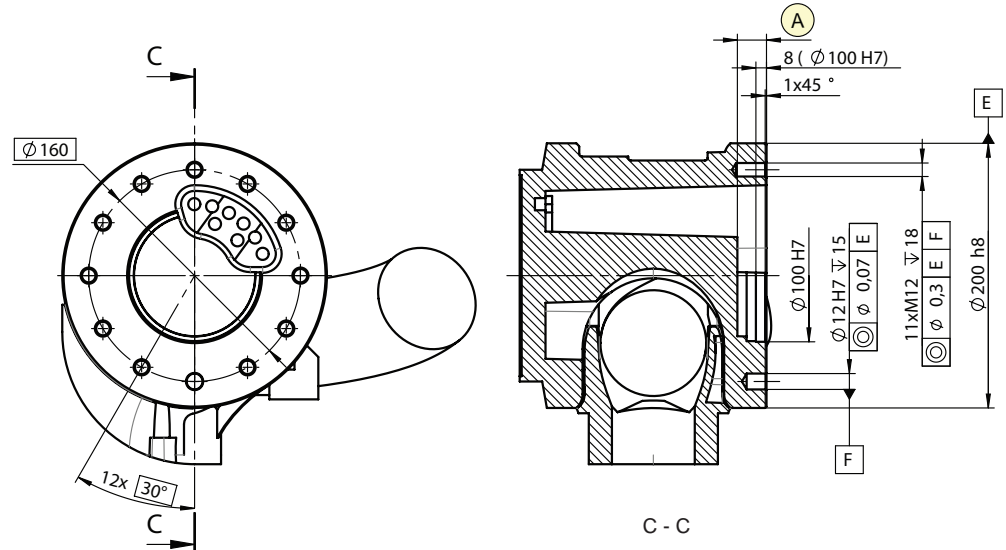

xx1300000290

A	Thread length: 18 mm.
---	-----------------------

Fastener quality

When fitting tools on the tool flange, only use screws with quality 12.9. For other equipment use suitable screws and tightening torque for your application.

2 Installation and commissioning

2.5.1 Axes with restricted working range

2.5 Restricting the working range

2.5.1 Axes with restricted working range

General

When installing the robot, make sure that it can move freely within its entire working space. If there is a risk that it may collide with other objects, its working space should be limited.

The working range of the following axes may be restricted:

- Axis 1, hardware (mechanical stop) and software.
- Axis 2, software.
- Axis 3, software.

This section describes how to install hardware that restricts the working range.



Note

Adjustments must also be made in the robot configuration software (system parameters). References to relevant manuals are included in the installation procedures.

Service stops for axis 2

There are service stops available for restricting the movement of axis 2 during floor standing service activities. Never use these service stops as mechanical stops for restriction of the working range during operation. See [Service stops on page 195](#).

2.5.2 Mechanically restricting the working range of axis 1

General

The working range of axis 1 is limited by fixed mechanical stops and adjustment of the system parameter configuration. The working range can be reduced by adding additional mechanical stops giving 15° graduation, between $\pm 5^\circ$ and $\pm 125^\circ$ in both directions.

Mechanical stops, axis 1

The illustration shows the mounting position of the stop pin and one of the additional mechanical stops available for axis 1.

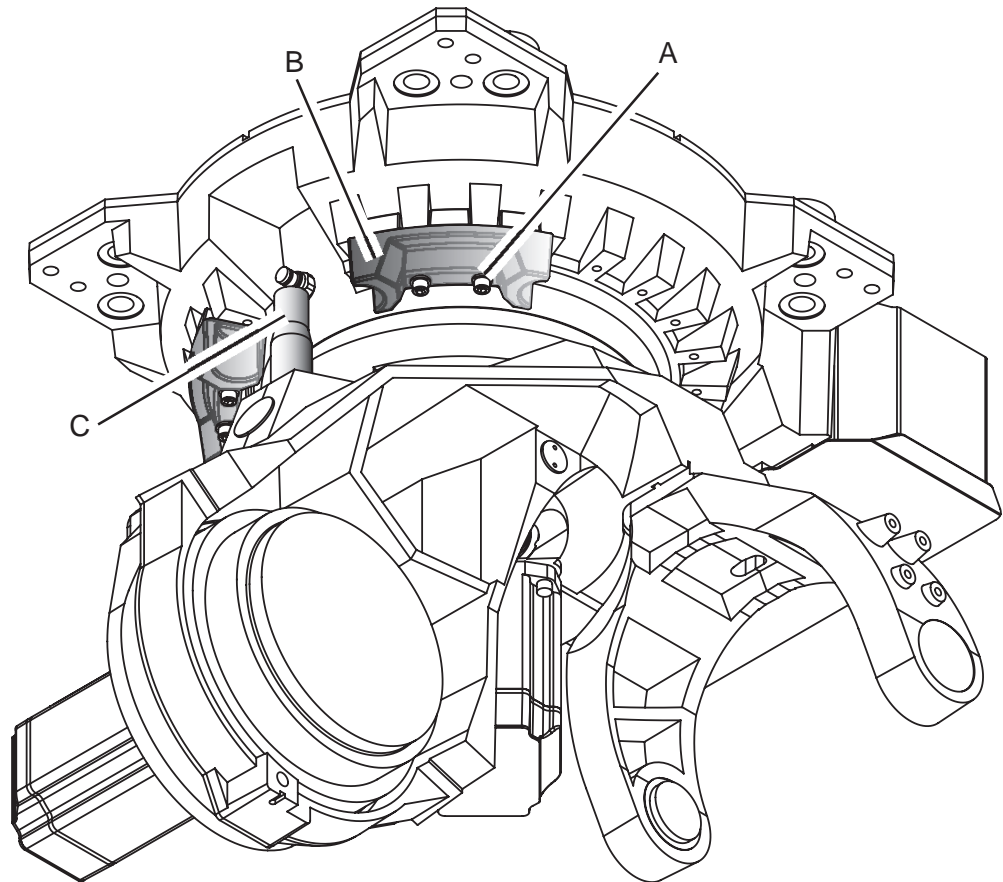

xx1600002066

A	Attachment screws M12x70 quality 12.9 Gleitmo 603 (2 pcs per additional mechanical stop)
B	Movable mechanical stop
C	Mechanical stop pin axis-1

Required equipment

Equipment, etc.	Article number	Note
Movable mechanical stop set, axis 1 (15°).	3HAC048533-003	Includes attachment screws and an assembly drawing.

Continues on next page

2 Installation and commissioning



2.5.2 Mechanically restricting the working range of axis 1

Continued

Equipment, etc.	Article number	Note
Standard toolkit	-	
<i>Technical reference manual - System parameters</i>	-	Article number is specified in section References on page 10 .

Installation, mechanical stops axis 1

Use this procedure to fit the additional mechanical stops to axis 1 of the robot. An assembly drawing is also enclosed with the product.

	Action	Note
1	 DANGER Turn off all: <ul style="list-style-type: none">• electric power supply to the robot• hydraulic pressure supply to the robot• air pressure supply to the robot Before entering the robot working area.	
2	Fit the additional mechanical stop to the frame according to the figure Mechanical stops, axis 1 on page 83 .	Tightening torque: 60 Nm.
3	Adjust the software working range limitations (system parameter configuration) to correspond to the mechanical limitations.	The system parameters that must be changed (<i>Upper joint bound</i> and <i>Lower joint bound</i>) are described in <i>Technical reference manual - System parameters</i> .
4	 WARNING If the mechanical stop pin is deformed after a hard collision, it must be replaced! Deformed <i>movable stops</i> and/or <i>additional stops</i> as well as deformed <i>attachment screws</i> must also be replaced after a hard collision.	

2.6 Electrical connections

2.6.1 Robot cabling and connection points

Introduction

Connect the robot and controller to each other after securing them to the foundation. The lists below specify which cables to use for each respective application.



DANGER

Turn off the main power before connecting any cables.



CAUTION

Verify that the serial number is according to the number(s) in the *Declaration of Incorporation (DoI)*.

Main cable categories

All cables between the robot and controller are divided into the following categories:

Cable category	Description
Robot cables	Handles power supply to and control of the robot's motors as well as feedback from the serial measurement board.
Fan cables (option)	Handles supply to and feedback from any cooling fan on the robot. Specified in the table Fan cables (option) on page 87 .
Customer cables (option)	Handles communication with equipment fitted on the robot by the customer, low voltage signals and high voltage power supply + protective ground. The customer cables also handle databus communication. See the product manual for the controller, see document number in References on page 10 .
DressPack cables (option)	Handles signals, process media and power feeding for customer use, regarding material handling or spot welding. See the <i>Product manual - DressPack/SpotPack IRB 6700</i> , see document number in References on page 10 .

Robot cables

These cables are included in the standard delivery. They are completely pre-manufactured and ready to plug in.

Cable sub-category	Description	Connection point, cabinet	Connection point, robot
Robot cable, power	Transfers drive power from the drive units in the controller to the robot motors.	XS1	R1.MP
Robot cable, signals	Transfers resolver data from and power supply to the serial measurement board.	XS2	R1.SMB

Continues on next page

2 Installation and commissioning

2.6.1 Robot cabling and connection points

Continued

Robot cable, power

Power cable length	Article number
7 m	3HAC026787-001
15 m	3HAC026787-002
22 m	3HAC026787-003
30 m	3HAC026787-004

Robot cable, signals

Signal cable length	Article number
7 m	3HAC068917-001
15 m	3HAC068918-001
22 m	3HAC068919-001
30 m	3HAC068920-001

Bending radius for static floor cables

The minimum bending radius is 10 times the cable diameter for static floor cables.

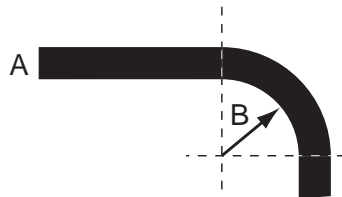

xx1600002016

A	Diameter
B	Diameter x10

Continues on next page

Grounding and bonding point on manipulator

There is a grounding/bonding point on the manipulator base. The grounding/bonding point is used for potential equalizing between control cabinet, manipulator and any peripheral devices.

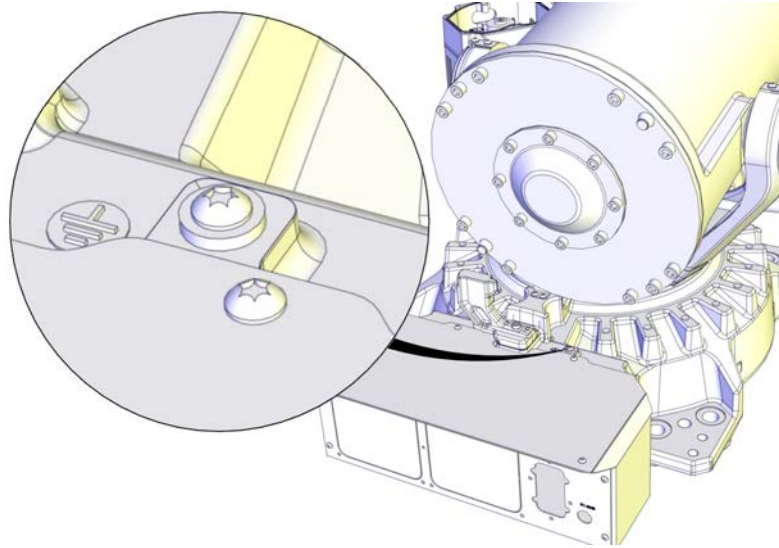

xx1500001600



Note

How to ground DressPack/SpotPack cables is detailed in the *Product manual - DressPack/SpotPack IRB 6700*, see the document number in [References on page 10](#).

Fan cables (option)

These cables are *not* included in the standard delivery, but are included in the delivery if the fan option is ordered. The cables are completely pre-manufactured and ready to plug in.

Cabling to be installed on the robot is specified in section [Installing the motor cooling fan \(option\) on page 90](#).

Cabling between robot base and control cabinet, cooling fans

The cables specified below are specific for the IRC5 controller and used when the robot is equipped with cooling fans. The cabling for the cooling fans runs all the way from the robot base to the inside of the cabinet. Fans can also be ordered without cables.

If equipping the robot with cooling fans, use the cabling specified below. The cables for cooling fans listed below are used together with a distributing cable, also specified below.

Cable	Art. no.	Connection point
Harness - cooling, 7 m	3HAC022723-001	Distributing cable: R1.FAN.SW2/3 Inside cabinet: A43.X10 and A43.X11

Continues on next page

2 Installation and commissioning

2.6.1 Robot cabling and connection points

Continued

Cable	Art. no.	Connection point
Harness - cooling, 15 m	3HAC022723-004	Distributing cable: R1.FAN.SW2/3 Inside cabinet: A43.X10 and A43.X11
Harness - cooling, 22 m	3HAC022723-005	Distributing cable: R1.FAN.SW2/3 Inside cabinet: A43.X10 and A43.X11
Harness - cooling, 30 m	3HAC022723-006	Distributing cable: R1.FAN.SW2/3 Inside cabinet: A43.X10 and A43.X11

2.7 Installation of options

2.7.1 Safety lamp (option for IRC5)

Description

A signal lamp with a yellow fixed light can be mounted on the robot, as a safety device.

Installation

See the assembly instruction delivered with the signal lamp.

Function

The lamp is active in MOTORS ON mode.

Further information

Further information about the MOTORS ON/MOTORS OFF mode may be found in the product manual for the controller.

2 Installation and commissioning

2.7.2 Installing the motor cooling fan (option)

2.7.2 Installing the motor cooling fan (option)

Location of the axis-1 motor cooling fan

A cooling fan can be installed on the axis-1 motor as an option. The fan is not possible to install on a robot with protection type Foundry Plus.

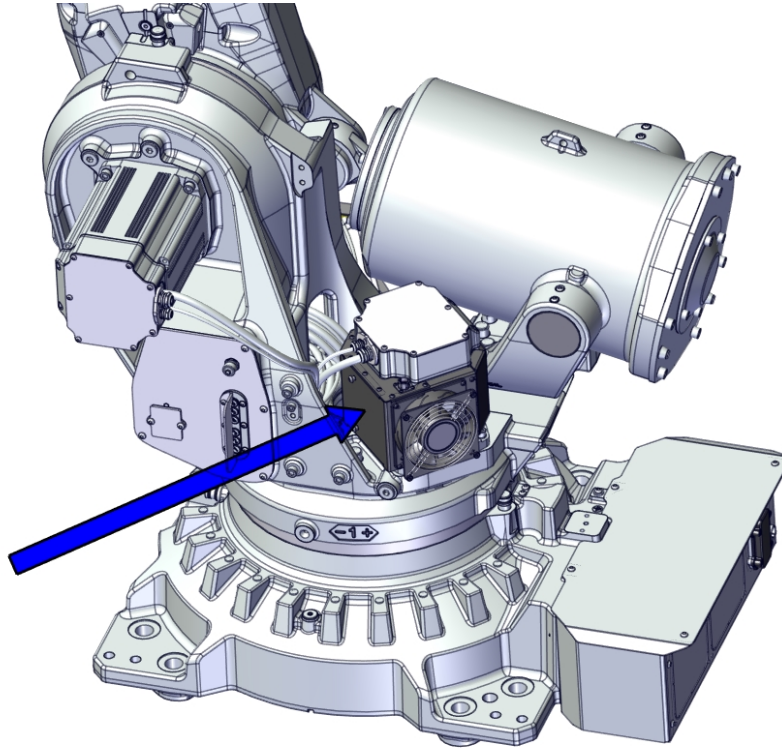

xx180000156

Required spare parts



Note

The spare part numbers that are listed in the table can be out of date. See the latest spare parts of the IRB 6700Inv / IRB 6700I via myABB Business Portal, www.abb.com/myABB.

Spare part	Article number	Note
Fan unit set	3HAC051149-001	Only available for the axis-1 motor. Can not be used together with protection type Foundry Plus. Includes fan unit, fan cable harness, customer connection plate and required fasteners.

Required tools and equipment

Equipment	Article number	Note
Standard toolkit	-	Content is defined in section Standard toolkit on page 724 .

Continues on next page

2 Installation and commissioning

2.7.2 Installing the motor cooling fan (option)

Continued

Required consumables

Consumable	Article number	Note
Cable straps	-	

Installing the cooling fan

Use these procedures to install the cooling fan.

Installing the fan

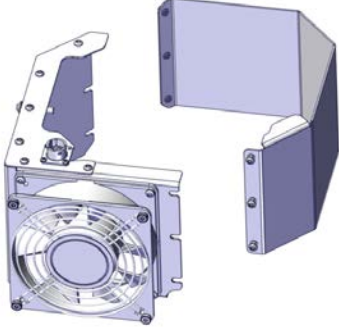
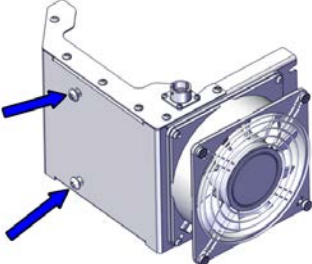
	Action	Note
1	Move the robot to its synchronization position.	
2	 DANGER Turn off all: <ul style="list-style-type: none">• electric power supply• hydraulic pressure supply• air pressure supply to the robot, before entering the safeguarded space.	
3	Remove the metal sheet frame from the fan unit assembly by loosening the six screws.	 xx1800000157
4	Loosen the two tightening screws so they don't damage the motor surface during installation.	 xx1800000159

Continues on next page

2 Installation and commissioning

2.7.2 Installing the motor cooling fan (option)

Continued

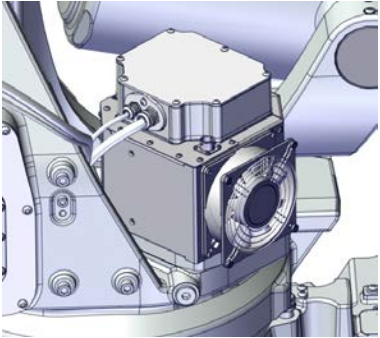
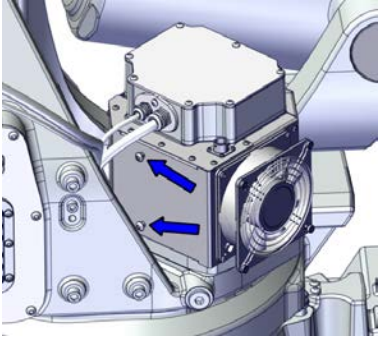
	Action	Note
5	Fit the fan unit sheets around the motor and fasten them to each other by tightening the six screws.	 <p>xx1800000158</p>
6	Lift the box so that it does not rest directly on the robot and secure the box against the motor with the two tightening screws. Tighten them properly so that the box is firmly attached to the motor.	 <p>xx1800000160</p>

Connecting the fan cabling

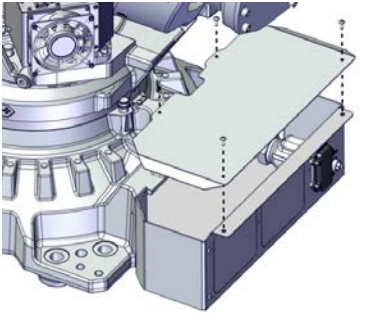
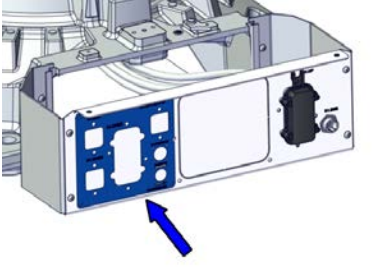
	Action	Note
1	Remove the rear cover plate.	 <p>xx1800000161</p>
2	Fit the customer connection plate.	 <p>xx1800000162</p>

Continues on next page

2 Installation and commissioning

2.7.2 Installing the motor cooling fan (option)

Continued

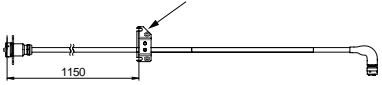
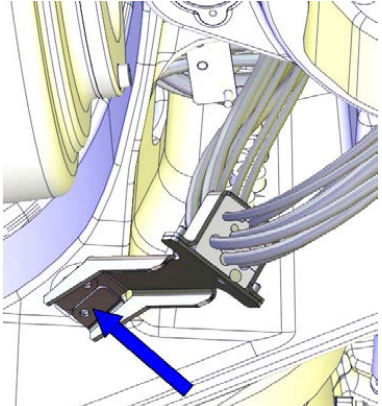
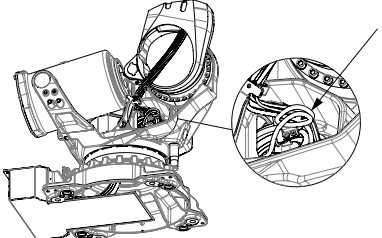
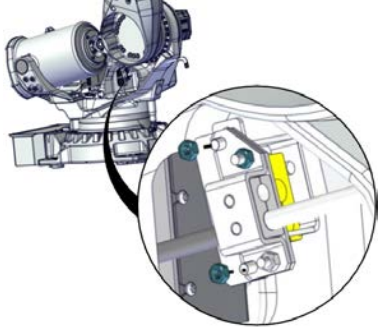
	Action	Note
3	<p>The bracket on the delivered fan cable must be fitted at a distance of 1,150 mm from the base connector.</p> <p>If adjustment is needed: measure the distance and make a mark with a pen or a piece of self adhesive. Loosen the cable bracket nuts and move the bracket to the mark. Tighten the nuts with 10 Nm after adjustment.</p>	 <p>xx1800000163</p>
4	<p>Loosen the frame cable clamp by unscrewing the screws.</p>	 <p>xx1300000542</p>
5	<p>Run the cabling up through the base and frame. Make a loop of the fan cable and use cable straps to strap it to the other cables.</p>	<p>Cable straps</p>  <p>xx1800000164</p>
6	<p>Secure the cable bracket inside the frame with the two enclosed nuts.</p>	 <p>xx1800000166</p>

Continues on next page

2 Installation and commissioning

2.7.2 Installing the motor cooling fan (option)

Continued

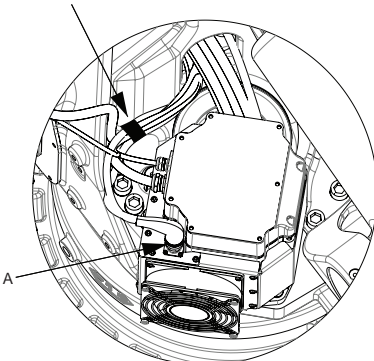
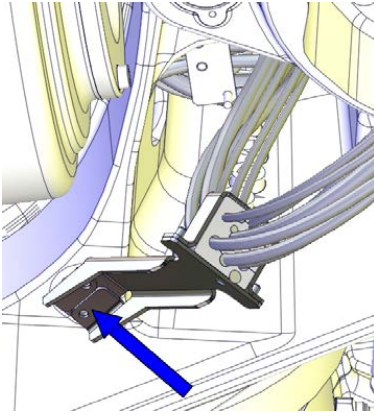
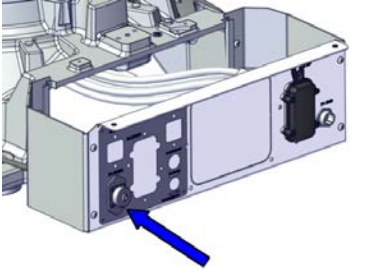
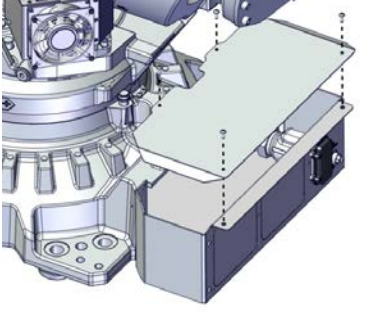
	Action	Note
7	Run the cable out through the side of the frame, at the axis-1 motor and connect the fan cable connector to the cooling fan.	 <p data-bbox="1029 694 1141 716">xx1800000165</p> <p data-bbox="1061 728 1332 795"> A Fan cable connector B Cable straps </p>
8	Strap the fan cable to the axis-1 and axis-2 motor cables.	
9	Refit the frame cable clamp with the screws.	 <p data-bbox="1029 1220 1141 1243">xx1300000542</p>
10	Connect the connector R1.SW2/3 to the base of the robot. Make sure that the cabling, run through the frame and base, is not twisted and runs freely from the robot cabling.	 <p data-bbox="1029 1556 1141 1579">xx1800000167</p>
11	Refit the rear cover plate to the robot base.	 <p data-bbox="1029 1937 1141 1960">xx1800000161</p>

Continues on next page

2 Installation and commissioning

2.7.2 Installing the motor cooling fan (option)

Continued

	Action	Note
12	Install additional cabling to and inside the controller.	Cabling and connection points are specified in Fan cables (option) on page 87 .

Adjustments in RobotWare

	Action	Note
1	Modify the settings in RobotWare to include the cooling fans.	Change the settings by using the Modify Controller System Wizard in the System Builder of RobotStudio. Read more about modifying the system in <i>Operating manual - RobotStudio</i> .

2 Installation and commissioning

2.8 Start of robot in cold environments

2.8 Start of robot in cold environments

Introduction

This section describes how to start the robot in a cold environment if it is not starting the normal way.

Problems with starting the robot

Event message from Motion Supervision

Use this procedure if an event message indicates a problem with Motion supervision at start-up. More information about Motion Supervision is found in *Technical reference manual - System parameters*.

	Action	Note
1	Turn off Motion Supervision.	
2	Start the robot.	
3	When the robot has reached normal working temperature, the Motion Supervision can be turned on again.	

Robot stopping with other event message

Use this procedure if the robot is not starting.

	Action	Note
1	Start the robot with its normal program but with reduced speed.	The speed can be regulated with the RAPID instruction <code>VelSet</code> .

Adjusting the speed and acceleration during warm-up

Depending on how cold the environment is and what program is being used, the speed might need to be ramped up until reached maximum. The table shows examples of how to adjust the speed:

Work cycles	AccSet	Speed/velocity
3 Work cycles	20, 20	v100 (100 mm/s)
5 Work cycles	40, 40	v400 (400 mm/s)
5 Work cycles	60, 60	v600 (600 mm/s)
5 Work cycles	100, 100	v1000 (1000 mm/s)
More than 5 Work cycles	100, 100	Max.

If the program consists of large wrist movements, it is possible that the reorientation velocity, which is always high in predefined velocities, needs to be included in the ramping up.

2.9 Test run after installation, maintenance, or repair

Safe handling

Use the following procedure after installation, maintenance, or repair, before initiating motion.



DANGER

Initiating motion without fulfilling the following aspects, may increase the risk for injury or cause damage to the robot.

	Action
1	Remove all tools and foreign objects from the robot and its working area.
2	Verify that the robot is properly secured to its position by all screws, before it is powered up.
3	Verify that any safety equipment installed to secure the position or restrict the robot motion during service activity is removed.
4	Verify that the fixture and work piece are well secured, if applicable.
5	Verify that all safety equipment is installed, as designed for the application.
6	Verify that no personnel are inside the safeguarded space.
7	If maintenance or repair has been done, verify the function of the part that was maintained.
8	Verify the application in the operating mode manual reduced speed.

Collision risks



CAUTION

When programming the movements of the robot, always identify potential collision risks before initiating motion.

This page is intentionally left blank

3 Maintenance

3.1 Introduction

Structure of this chapter

This chapter describes all the maintenance activities recommended for the IRB 6700Inv / IRB 6700I.

It is based on the maintenance schedule found at the beginning of the chapter. The schedule contains information about required maintenance activities including intervals, and refers to procedures for the activities.

Each procedure contains all the information required to perform the activity, including required tools and materials.

The procedures are gathered in different sections and divided according to the maintenance activity.

Safety information

Observe all safety information before conducting any service work.

There are general safety aspects that must be read through, as well as more specific safety information that describes the danger and safety risks when performing the procedures. Read the chapter [Safety on page 17](#) before performing any service work.

The maintenance must be done by qualified personnel in accordance with the safety requirements set forth in the applicable national and regional standards and regulations.



Note

If the IRB 6700Inv / IRB 6700I is connected to power, always make sure that the IRB 6700Inv / IRB 6700I is connected to protective earth and a residual current device (RCD) before starting any maintenance work.

For more information see:

- *Product manual - OmniCore V250XT*
- *Product manual - IRC5*
- *Product manual - IRC5 Panel Mounted Controller*
- [Robot cabling and connection points on page 85.](#)

3 Maintenance

3.2.1 Specification of maintenance intervals

3.2 Maintenance schedule and expected component life

3.2.1 Specification of maintenance intervals

Introduction

The intervals are specified in different ways depending on the type of maintenance activity to be carried out and the working conditions of the IRB 6700Inv / IRB 6700I:

- Calendar time: specified in months regardless of whether the system is running or not.
- Operating time: specified in operating hours. More frequent running means more frequent maintenance activities.

Robots with the functionality *Service Information System* activated can show active counters in the device browser in RobotStudio, or on the FlexPendant.

Overhaul

Depending on application and operational environment a complete overhaul may be necessary in average around 40000 hours.

ABB Connected Services and its Assessment tools can help you to identify the real stress level of your robot, and define the optimal ABB support to maintain your robot working.

Contact your local ABB Customer Service to get more information.

3.2.2 Maintenance schedule

Scheduled and non-predictable maintenance

The robot must be maintained regularly to ensure proper function. The maintenance activities and intervals are specified in the table below.

Non-predictable situations also give rise to inspections of the robot. Any damages must be attended to immediately!

Life of each component

The inspection intervals *do not* specify the life of each component. Values for these are specified in the section [Expected component life on page 103](#)

Activities and intervals, standard equipment

The table below specifies the required maintenance activities and intervals:

Maintenance activities	Regularly	Every 6 months	Every 12 months	Every 18 months	Every 24 months	Every 36 months	Every 12,000 hours /	Every 20,000 hours /	Every 40,000 hours /	Reference
Cleaning activities										
Cleaning the robot	x									Cleaning the IRB 6700Inv / IRB 6700I on page 184
Inspection activities										
Inspecting the motor seal			x							Inspecting the motor seal on page 104
Inspecting the oil level in gearboxes										Inspect the oil level in the actual gearbox if there is a suspected leakage, after an oil change or a maintenance or repair activity where draining and filling oil is required.
Inspecting the balancing device			x							Inspecting the balancing device on page 125
Inspecting the robot harness			x ii							Inspecting the cable harness on page 129
Inspecting the velcro straps	x									Inspecting the cable harness on page 129
Inspecting the information labels			x							Inspecting the information labels on page 132
Inspecting the transportation lock screw	x									
Inspecting the dampers			x							Inspecting the dampers on page 143

Continues on next page

3 Maintenance

3.2.2 Maintenance schedule

Continued

Maintenance activities	Regularly	Every 6 months	Every 12 months	Every 18 months	Every 24 months	Every 36 months	Every 12,000 hours ⁱ	Every 20,000 hours ⁱ	Every 40,000 hours ⁱ	Reference
Inspecting the mechanical stop			x							Inspecting the axis-1 mechanical stop pin on page 140
Replacement/changing activities										
Changing the oil in axis-1 gearbox								x		Changing oil, axis-1 gearbox on page 149
Changing the oil in axis-2 gearbox								x		Changing oil, axis-2 gearbox on page 156
Changing the oil in axis-3 gearbox								x		Changing oil, axis-3 gearbox on page 162
Changing the oil in axis-4 gearbox								x		Changing oil, axis-4 gearbox on page 167
Changing the oil in axis-5 gearbox								x		Changing oil, axis-5 gearbox on page 171
Changing the oil in axis-6 gearbox								x		Changing oil, axis-6 gearbox on page 175
Replacing the SMB battery pack						x ⁱⁱⁱ				Replacing the SMB battery on page 179
Lubrication activities										
Lubricating the balancing device bearings							x ^{iv}			Lubricating the spherical roller bearing, balancing device on page 182
Overhaul										
Overhaul of complete robot									x	

- i Operating hours counted by the DTC = Duty time counter.
- ii Replace when damage or cracks is detected or life limit is approaching that specified in section [Expected component life on page 103](#).
- iii The battery is to be replaced at given maintenance interval or at battery low alert.
- iv Always lubricate the front eye bearing after refitting the shaft of the balancing device.

3.2.3 Expected component life

General

The expected life of a specific component of the robot can vary greatly depending on how hard it is run.

Expected component life - protection type Standard

Component	Expected life	Note
Cable harness Normal usage ⁱ	40,000 hours ⁱⁱ	Not including: <ul style="list-style-type: none"> • Possible SpotPack harnesses • Optional upper arm harnesses
Cable harness Extreme usage ⁱⁱⁱ	20,000 hours ⁱⁱ	Not including: <ul style="list-style-type: none"> • Possible SpotPack harnesses • Optional upper arm harnesses
Balancing device	40,000 hours ^{iv}	
Gearboxes ^v	40,000 hours	

- ⁱ Examples of "normal usage" in regard to movement: most material handling applications.
- ⁱⁱ Severe chemical or thermal environments, or similar environments, can result in shortened life expectancy.
- ⁱⁱⁱ Examples of "extreme usage" in regard to movement: press tending, very severe palletizing applications, major use of axis 1 movement.
- ^{iv} The given life for the balancing device is based on a test cycle of 4,000,000 cycles that starts from the initial position and goes to maximum extension, and back. Deviations from this cycle will result in differences in expected life!
- ^v The SIS for an IRC5 system is described in the *Operating manual - Service Information System*.

3 Maintenance

3.3.1 Inspecting the motor seal

3.3 Inspection activities

3.3.1 Inspecting the motor seal

Purpose of evacuation holes

The motors include evacuation on the motor flange to indicate failure of primary sealing between the gearbox and the motor.

Location of evacuation hole on motor

The evacuation hole is located on each motor flange. The figure shows axis-1 motor as an example.

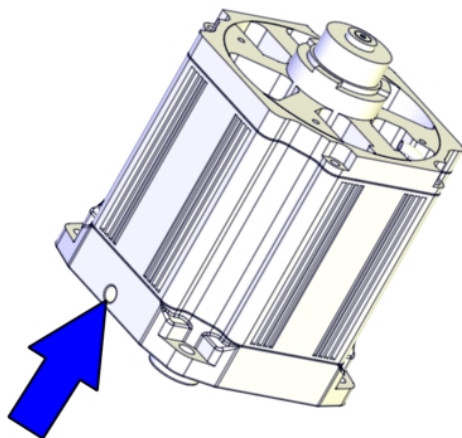

xx1500001057

Plug in the evacuation hole



New motors have a transparent plug/sight glass installed in the evacuation hole. Remove the plug or drill a drainage hole with diameter 3 mm, if an open evacuation hole is required instead.



xx2200002188

Continues on next page

Inspecting the evacuation hole

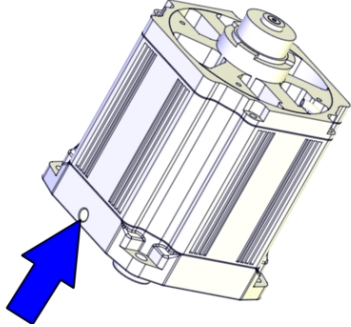
	Action	Note
1	 <p>DANGER</p> <p>Turn off all:</p> <ul style="list-style-type: none"> • electric power supply • hydraulic pressure supply • air pressure supply <p>to the robot, before entering the robot working area.</p>	
2	 <p>WARNING</p> <p>Handling gearbox oil involves several safety risks, see Gearbox lubricants (oil or grease) on page 33.</p>	
3	<p>Do a leakage check of the sight glass/evacuation hole of each motor.</p> <p>If any oil is available on the sight glass or if any oil has been spilled out from the evacuation hole, replacement of the motor is recommended.</p> <p> Note</p> <p>If oil is present in the evacuation it is an indication that the primary seal of the motor is leaking. A secondary seal after the evacuation is keeping the oil out from the motor, but it is still recommended to replace the motor at a suitable timing if oil is present in the evacuation.</p>	 <p>xx1500001057</p> <p>Replacing of motors is described in the repair chapter Motors on page 461.</p>

3 Maintenance

3.3.2 Inspecting the oil level in axis-1 gearbox

3.3.2 Inspecting the oil level in axis-1 gearbox

Two alternative ways of checking the oil level

There are two alternatives for checking the oil level on an IRB 6700Inv, inverted or floor standing. The first section below describes inverted measuring of oil level and the second floor standing measuring of oil.

Location of oil plug

The oil plug through which the oil level is inspected is located as shown in the figure.

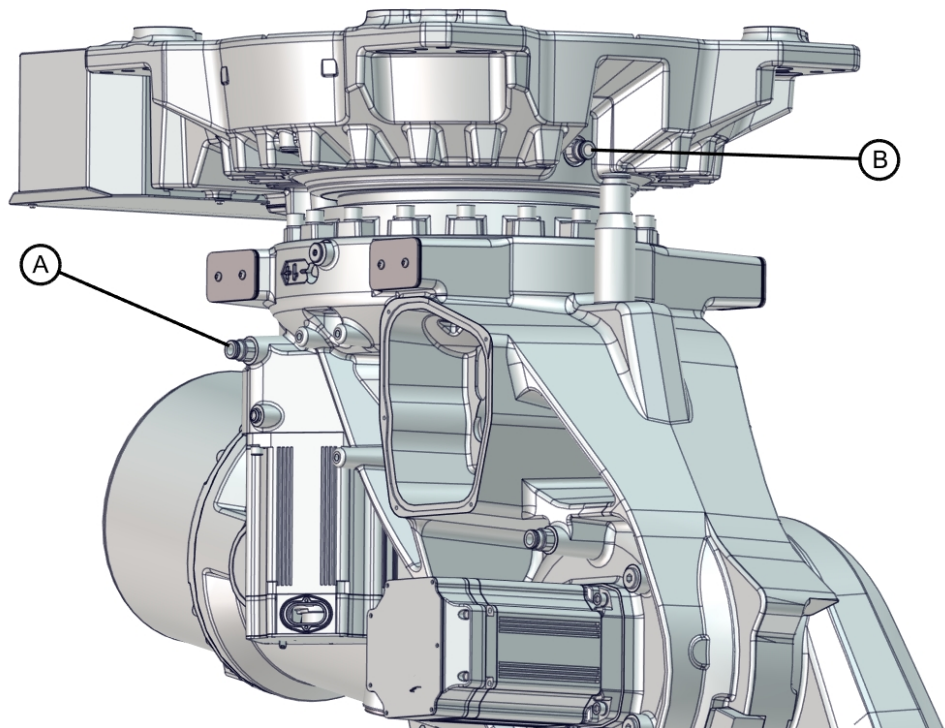

xx1600002030

A	Oil plug
B	Venting hole

Required tools

Equipment	Article number	Note
Standard toolkit	-	Content is defined in section Standard toolkit on page 724 .
Oil level gauge	3HAC061881-001	Assemble the extender to be able to use the oil level gauge when the fork lift accessories are mounted. The tool also includes an air vent.

Continues on next page

Required consumables and wear parts



Consumables	Article number	Note
Lubricating oil	-	Information about the oil is found in <i>Technical reference manual - Lubrication in gearboxes</i> .
O-ring, G 1/2"	3HAC061327-059	Used on oil plug. Always replace when refitting oil plug.

Required documents

Document name	Document number
<i>Technical reference manual - Lubrication in gearboxes</i>	3HAC042927-001

Inspecting the oil level in axis-1 gearbox

Use this procedure to inspect the oil level in the gearbox, when the robot is inverted.

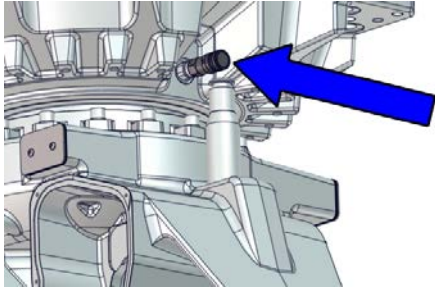
	Action	Note
1	 DANGER Turn off all: <ul style="list-style-type: none"> • electric power supply • hydraulic pressure supply • air pressure supply to the robot, before entering the robot working area.	
2	 WARNING Handling gearbox oil involves several safety risks, see Gearbox lubricants (oil or grease) on page 33 .	
3	Make sure that the oil temperature is $+25^{\circ}\text{C} \pm 10^{\circ}\text{C}$.  CAUTION The gearbox can contain an <i>excess pressure</i> that can be hazardous. Open the oil plug carefully in order to let the excess pressure out.	
4	Open the oil plug and install the ventilating valve.	 xx1700000349

Continues on next page

3 Maintenance

3.3.2 Inspecting the oil level in axis-1 gearbox

Continued

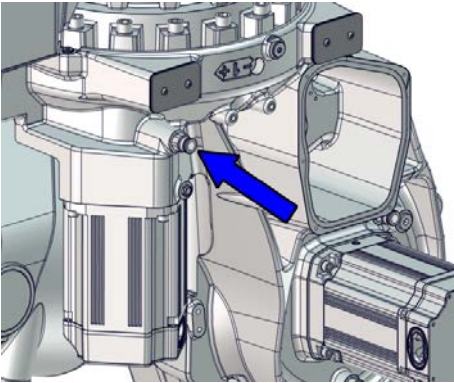
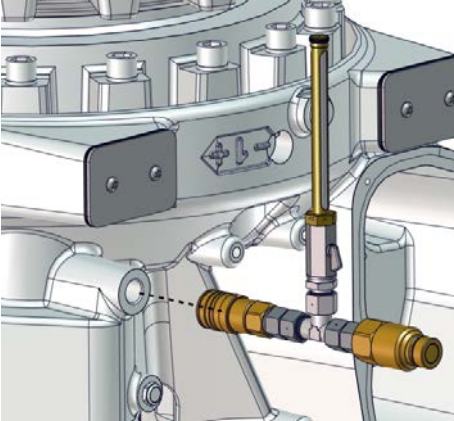
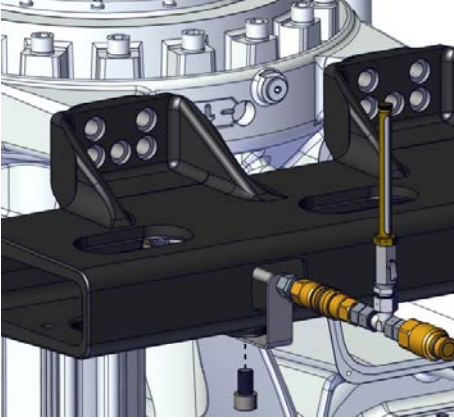

	Action	Note
5	Remove the protective cap.	 xx1600002042
6	Make sure that the valve is closed (horizontal) and mount the Oil level gauge	
7	Open the valve slowly to avoid air bubbles in the oil. Check the oil level using the Oil level gauge. Required oil level is: Between level measurement marks on tool	 xx1600002097 <p>If the Fork lift accessory set is assembled, fasten the extender screw in the fork lift pocket.</p>  xx1700000314

Continues on next page

	Action	Note
8	Add or drain oil, if required.	Type of oil and total amount is detailed in <i>Technical reference manual - Lubrication in gearboxes</i> . Further information about how to drain or fill with oil is found in section <i>Changing oil, axis-1 gearbox on page 149</i> .
9	Refit the protective cap.	
10	 DANGER Make sure all safety requirements are met when performing the first test run. See <i>Test run after installation, maintenance, or repair on page 97</i> .	

Inspecting the oil level in axis-1 gearbox

Use this procedure to inspect the oil level in the gearbox, when the robot is floor-standing.

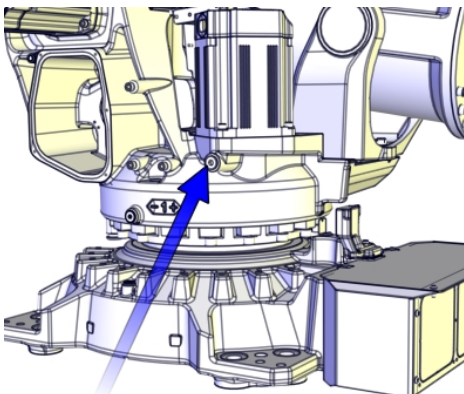
	Action	Note
1	 DANGER Turn off all: <ul style="list-style-type: none"> • electric power supply • hydraulic pressure supply • air pressure supply to the robot, before entering the robot working area.	
2	 WARNING Handling gearbox oil involves several safety risks, see <i>Gearbox lubricants (oil or grease) on page 33</i> .	
3	Make sure that the oil temperature is $+25^{\circ}\text{C} \pm 10^{\circ}\text{C}$.	
4	Open the oil plug.	 <p>xx1500001655</p>

Continues on next page

3 Maintenance

3.3.2 Inspecting the oil level in axis-1 gearbox

Continued

	Action	Note
5	Check the oil level. Required oil level is: 0 - 5 mm below the oil plug hole.	
6	Add or drain oil, if required.	Type of oil and total amount is detailed in <i>Technical reference manual - Lubrication in gearboxes</i> . Further information about how to drain or fill with oil is found in section Changing oil, axis-1 gearbox on page 149 .
7	Refit the oil plug with a new o-ring.	O-ring, G 1/2": 3HAC061327-059 Tightening torque: 24 Nm.
8	 DANGER Make sure all safety requirements are met when performing the first test run. See Test run after installation, maintenance, or repair on page 97 .	

3.3.3 Inspecting the oil level in axis-2 gearbox

Location of the oil plug

The oil plug for inspection is located as shown in the figure.

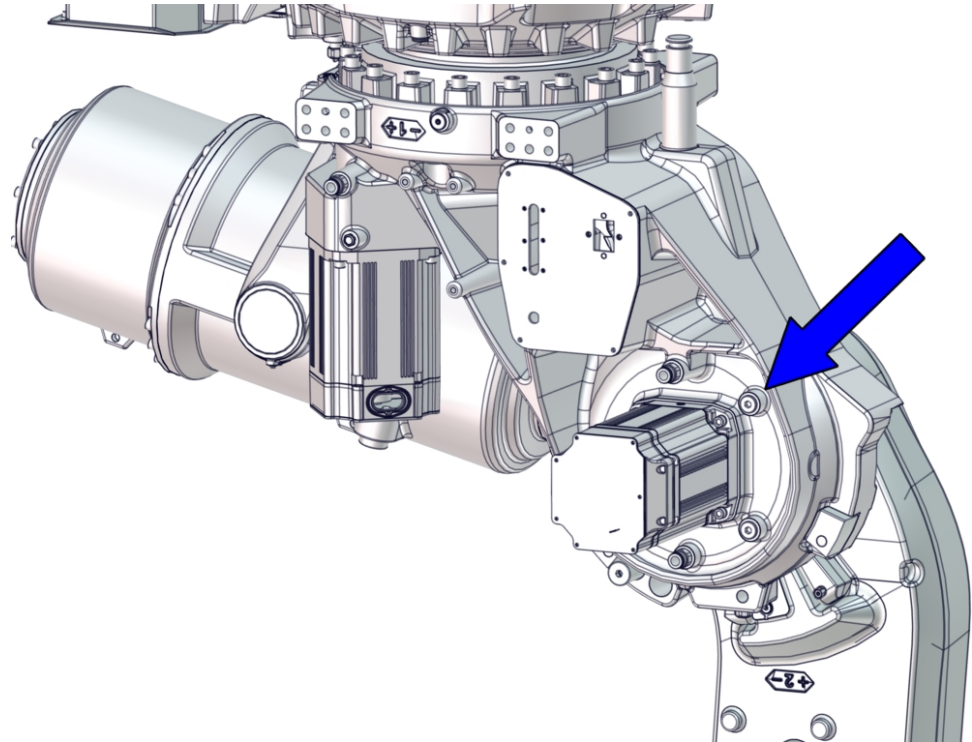

xx1600002043

Tightening torque: 24 Nm

Required tools and equipment

Equipment	Article number	Note
Standard toolkit	-	Content is defined in section Standard toolkit on page 724 .

Required consumables and wear parts

Consumables	Article number	Note
Lubricating oil	-	Information about the oil is found in <i>Technical reference manual - Lubrication in gearboxes</i> .
O-ring, G 1/2"	3HAC061327-059	Used on oil plug. Always replace when refitting oil plug.

Required documents

Document name	Document number
<i>Technical reference manual - Lubrication in gearboxes</i>	3HAC042927-001

Continues on next page





3 Maintenance

3.3.3 Inspecting the oil level in axis-2 gearbox

Continued

Inspecting the oil level in axis-2 gearbox

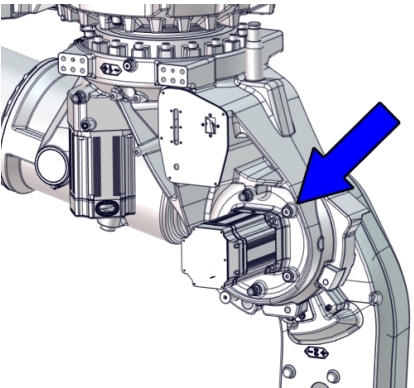
Use this procedure to inspect the oil level in the gearbox.

	Action	Note
1	<p> DANGER</p> <p>Turn off all:</p> <ul style="list-style-type: none"> • electric power supply • hydraulic pressure supply • air pressure supply <p>to the robot, before entering the robot working area.</p>	
2	<p> WARNING</p> <p>Handling gearbox oil involves several safety risks, see Gearbox lubricants (oil or grease) on page 33.</p>	
3	<p>Make sure that the oil temperature is $+25^{\circ}\text{C} \pm 10^{\circ}\text{C}$.</p>	
4	<p>Open the oil plug.</p>	 <p>xx1600002044</p>
5	<p>Check the oil level. Required oil level is: 0-15 mm below the oil plug hole.</p>	
6	<p>Add or drain oil, if required.</p>	<p>Type of oil and total amount is detailed in <i>Technical reference manual - Lubrication in gearboxes</i>.</p> <p>Further information about how to drain or fill with oil is found in section Changing oil, axis-2 gearbox on page 156.</p>
7	<p>Refit the oil plug with a new o-ring.</p>	<p>O-ring, G 1/2": 3HAC061327-059 Tightening torque: 24 Nm.</p>
8	<p> DANGER</p> <p>Make sure all safety requirements are met when performing the first test run. See Test run after installation, maintenance, or repair on page 97.</p>	

3.3.4 Inspecting the oil level in axis-3 gearbox

Location of oil plug

The gearbox has a level plug that is located as shown in the figure.

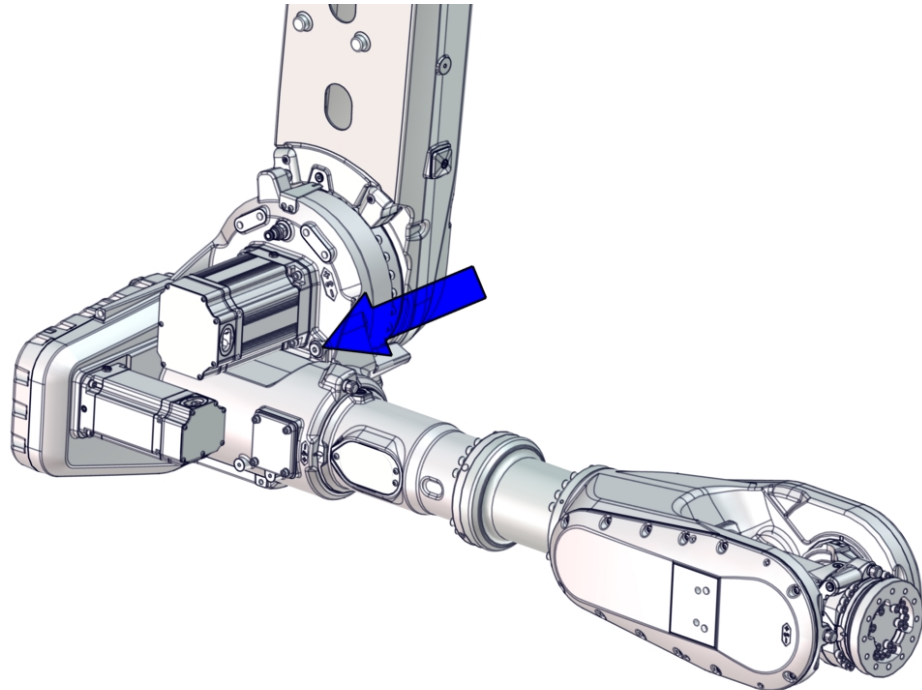

xx1600002045

Tightening torque: 24 Nm

Required tools

Equipment, etc.	Article number	Note
Standard toolkit	-	Content is defined in section Standard toolkit on page 724 .

Required consumables and wear parts

Consumables	Article number	Note
Lubricating oil	-	Information about the oil is found in <i>Technical reference manual - Lubrication in gearboxes</i> .
O-ring, G 1/2"	3HAC061327-059	Used on oil plug. Always replace when refitting oil plug.

Required documents

Document name	Document number
<i>Technical reference manual - Lubrication in gearboxes</i>	3HAC042927-001

Continues on next page



3 Maintenance

3.3.4 Inspecting the oil level in axis-3 gearbox

Continued

Inspecting the oil level in axis-3 gearbox

Use this procedure to inspect the oil level in the gearbox.

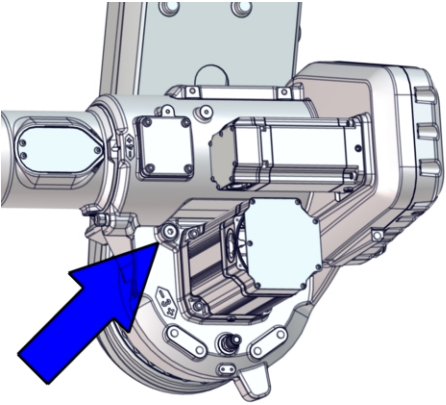
	Action	Note
1	Jog the robot into position: <ul style="list-style-type: none"> • Axis 1: • Axis 2: 0° • Axis 3: 180° (horizontal) • Axis 4: • Axis 5: • Axis 6: no significance 	
2	 DANGER Turn off all: <ul style="list-style-type: none"> • electric power supply • hydraulic pressure supply • air pressure supply to the robot, before entering the robot working area.	
3	Make sure that the oil temperature is $+25^{\circ}\text{C} \pm 10^{\circ}\text{C}$.	
4	 WARNING Handling gearbox oil involves several safety risks, see Gearbox lubricants (oil or grease) on page 33 .	
5	Open the oil plug.	 <p style="text-align: right; font-size: small;">xx1600002046</p>
6	Check the oil level. Required oil level is: 0 - 20 mm below the oil plug hole.	
7	Add or drain oil, if required.	Type of oil and total amount is detailed in <i>Technical reference manual - Lubrication in gearboxes</i> . Further information about how to drain or fill with oil is found in section Changing oil, axis-3 gearbox on page 162 .

Continues on next page

	Action	Note
8	Refit the oil plug with a new o-ring.	O-ring, G 1/2": 3HAC061327-059 Tightening torque: 24 Nm.
9	 DANGER Make sure all safety requirements are met when performing the first test run. See Test run after installation, maintenance, or repair on page 97 .	

3 Maintenance

3.3.5 Inspecting the oil level in axis-4 gearbox

3.3.5 Inspecting the oil level in axis-4 gearbox

Location of oil plug

The gearbox has a level plug that is located as shown in the figure.

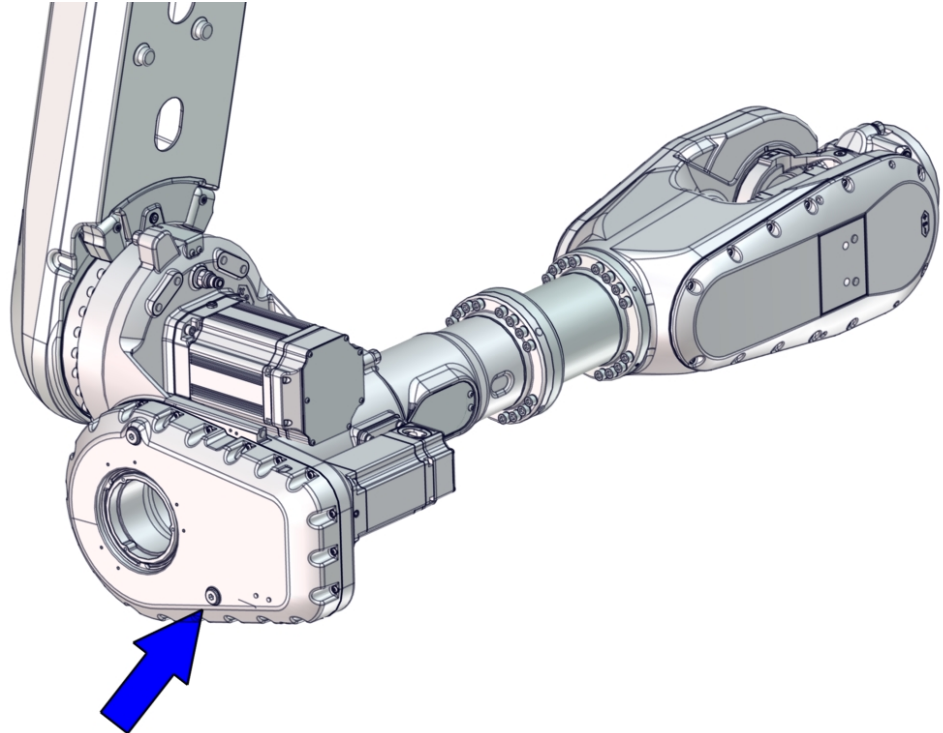

xx1600002047

Tightening torque: 24 Nm

Required tools

Equipment, etc.	Article number	Note
Standard toolkit	-	Content is defined in section Standard toolkit on page 724 .

Required consumables and wear parts

Consumables	Article number	Note
Lubricating oil	-	Information about the oil is found in <i>Technical reference manual - Lubrication in gearboxes</i> .
O-ring, G 1/2"	3HAC061327-059	Used on oil plug. Always replace when refitting oil plug.



Required documents

Document name	Document number
<i>Technical reference manual - Lubrication in gearboxes</i>	3HAC042927-001

Continues on next page

Inspecting the oil level in axis-4 gearbox

Use this procedure to inspect the oil level in the gearbox.

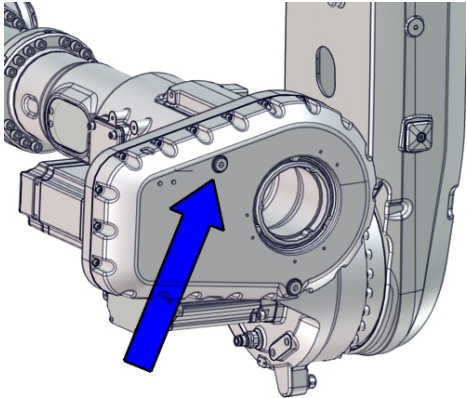
	Action	Note
1	Jog the robot into position: <ul style="list-style-type: none"> • Axis 1: • Axis 2: 0° • Axis 3: 180° • Axis 4: • Axis 5: • Axis 6: no significance 	
2	 DANGER Turn off all: <ul style="list-style-type: none"> • electric power supply • hydraulic pressure supply • air pressure supply to the robot, before entering the robot working area.	
3	Make sure that the oil temperature is $+25^{\circ}\text{C} \pm 10^{\circ}\text{C}$.	
4	 WARNING Handling gearbox oil involves several safety risks, see Gearbox lubricants (oil or grease) on page 33 .	
5	Open the oil plug.	 <p style="text-align: right; font-size: small;">xx1600002048</p>
6	Check the oil level. Required oil level is: 0 - 10 mm below the oil plug hole.	
7	Add or drain oil, if required.	Type of oil and total amount is detailed in <i>Technical reference manual - Lubrication in gearboxes</i> . Further information about how to drain or fill with oil is found in section Changing oil, axis-4 gearbox on page 167 .

Continues on next page

3 Maintenance

3.3.5 Inspecting the oil level in axis-4 gearbox

Continued

	Action	Note
8	Refit the oil plug with a new o-ring.	O-ring, G 1/2": 3HAC061327-059 Tightening torque: 24 Nm.
9	 DANGER Make sure all safety requirements are met when performing the first test run. See Test run after installation, maintenance, or repair on page 97 .	

3.3.6 Inspecting the oil level in axis-5 gearbox

Location of oil plug

The gearbox has a level plug that is located as shown in the figure.

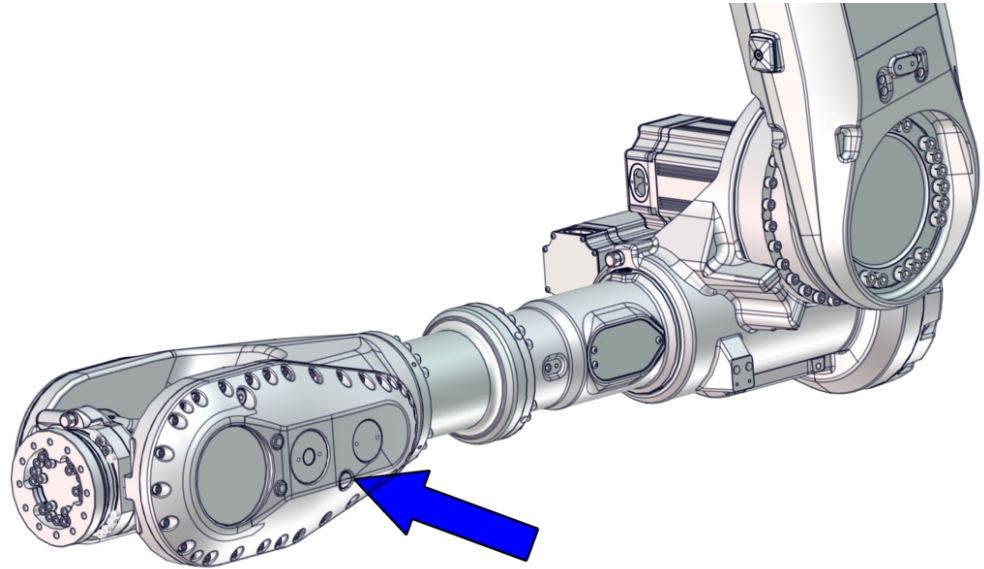

xx170000315

Tightening torque: 24 Nm

Required tools

Equipment, etc.	Article number	Note
Standard toolkit	-	Content is defined in section Standard toolkit on page 724 .

Required consumables and wear parts

Consumables	Article number	Note
Lubricating oil	-	Information about the oil is found in <i>Technical reference manual - Lubrication in gearboxes</i> .
O-ring, G 1/2"	3HAC061327-059	Used on oil plug. Always replace when refitting oil plug.

Required documents

Document name	Document number
<i>Technical reference manual - Lubrication in gearboxes</i>	3HAC042927-001

Continues on next page



3 Maintenance

3.3.6 Inspecting the oil level in axis-5 gearbox

Continued

Inspecting the oil level in axis-5 gearbox

Use this procedure to inspect the oil level in the gearbox.

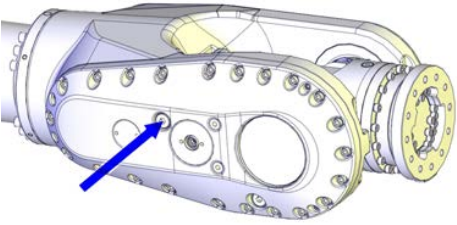
	Action	Note
1	Jog the robot into position: <ul style="list-style-type: none"> • Axis 1: • Axis 2: 0° • Axis 3: • Axis 4: 180° • Axis 5: • Axis 6: no significance 	
2	 DANGER Turn off all: <ul style="list-style-type: none"> • electric power supply • hydraulic pressure supply • air pressure supply to the robot, before entering the robot working area.	
3	Make sure that the oil temperature is $+25^{\circ}\text{C} \pm 10^{\circ}\text{C}$.	
4	 WARNING Handling gearbox oil involves several safety risks, see Gearbox lubricants (oil or grease) on page 33 .	
5	Open the oil plug.	 <p style="text-align: right; font-size: small;">xx1200000959</p>
6	Check the oil level. Required oil level is: 0 - 10 mm below the oil plug hole.	
7	Add or drain oil, if required.	Type of oil and total amount is detailed in <i>Technical reference manual - Lubrication in gearboxes</i> . Further information about how to drain or fill with oil is found in section Changing oil, axis-5 gearbox on page 171 .
8	Refit the oil plug with a new o-ring.	O-ring, G 1/2": 3HAC061327-059 Tightening torque: 24 Nm.

Continues on next page

	Action	Note
9	 DANGER Make sure all safety requirements are met when performing the first test run. See Test run after installation, maintenance, or repair on page 97 .	

3 Maintenance

3.3.7 Inspecting the oil level in axis-6 gearbox

3.3.7 Inspecting the oil level in axis-6 gearbox

Location of oil plug

The oil plug through which the oil level is inspected is located as shown in the figure.

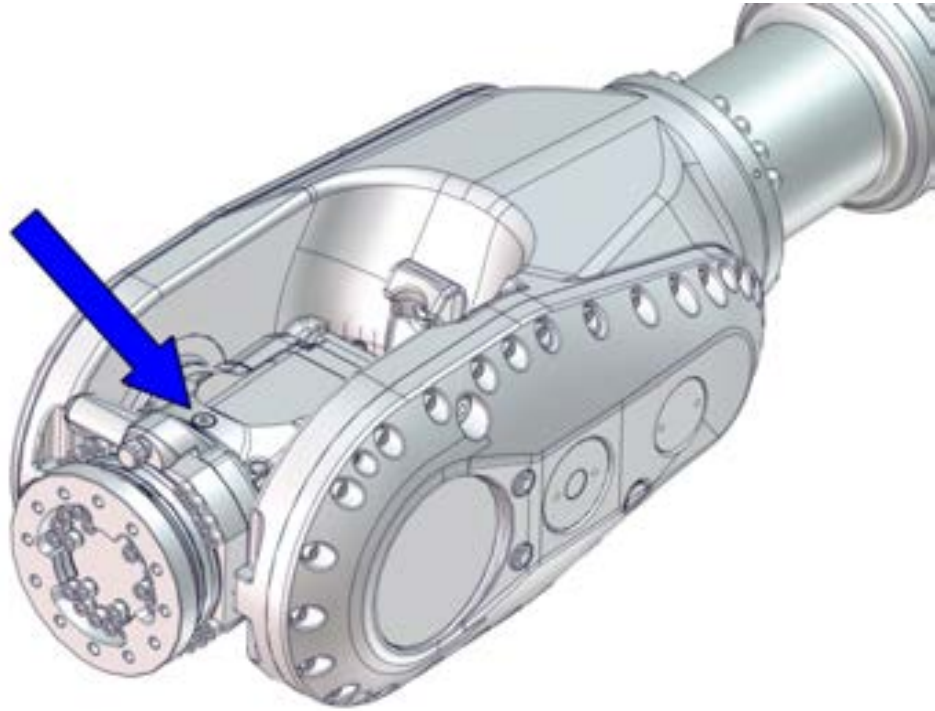

xx1600002049

Tightening torque: 24 Nm

Required tools

Equipment, etc.	Article number	Note
Standard toolkit	-	Content is defined in section Standard toolkit on page 724 .

Required consumables and wear parts

Consumables	Article number	Note
Lubricating oil	-	Information about the oil is found in <i>Technical reference manual - Lubrication in gearboxes</i> .
O-ring, G 1/4"	3HAC061327-060	Used on oil plug. Always replace when refitting oil plug.

Required documents



Document name	Document number
<i>Technical reference manual - Lubrication in gearboxes</i>	3HAC042927-001

Continues on next page

Inspecting the oil level in axis-6 gearbox

Use this procedure to inspect the oil level in the gearbox.

The procedure includes two alternative positions for axis 5, where one of the positions makes it possible to use the filling plug as a level plug.

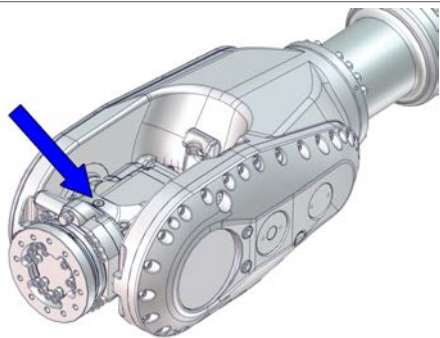
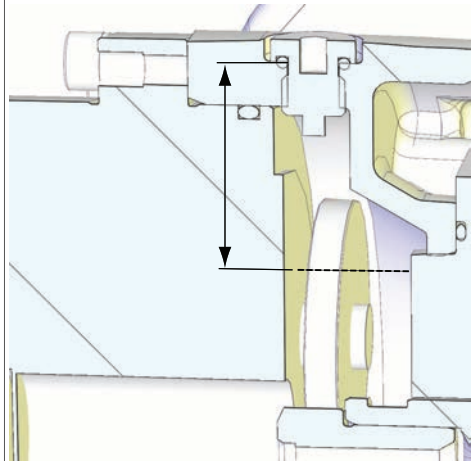
	Action	Note
1	Run the robot to calibration position.	
2	 DANGER Turn off all: <ul style="list-style-type: none"> • electric power supply • hydraulic pressure supply • air pressure supply to the robot, before entering the robot working area.	
3	Make sure that the oil temperature is $+25^{\circ}\text{C} \pm 10^{\circ}\text{C}$.	
4	 WARNING Handling gearbox oil involves several safety risks, see Gearbox lubricants (oil or grease) on page 33 .	
5	Open the oil plug.	 xx1600002049
6	Method 1 Check the oil level. <ul style="list-style-type: none"> • Required oil level is: $50\text{ mm} \pm 5\text{ mm}$ below the sealing surface of the oil plug. 	 xx1300000693

Continues on next page

3 Maintenance

3.3.7 Inspecting the oil level in axis-6 gearbox

Continued

	Action	Note
7	Method 2 Rotate axis 5 -77°. Required oil level is: 0 - 10 mm below the oil plug hole.	
8	Add or drain oil, if required.	Type of oil and total amount is detailed in <i>Technical reference manual - Lubrication in gearboxes</i> . Further information about how to drain or fill with oil is found in section Changing oil, axis-6 gearbox on page 175 .
9	Refit the oil plug with a new o-ring.	O-ring, G 1/4": 3HAC061327-060 Tightening torque: 24 Nm.
10	 DANGER Make sure all safety requirements are met when performing the first test run. See Test run after installation, maintenance, or repair on page 97 .	

3.3.8 Inspecting the balancing device

General

Several points are to be checked on the balancing device during the inspection. This section describes how to perform the inspection regarding:

- dissonance
- damage
- leakage
- contamination / lack of free space.

Inspection points, balancing device

The balancing device is located at the top rear of the frame as shown in the figure. The figure also shows the inspection points, further described in the instructions.

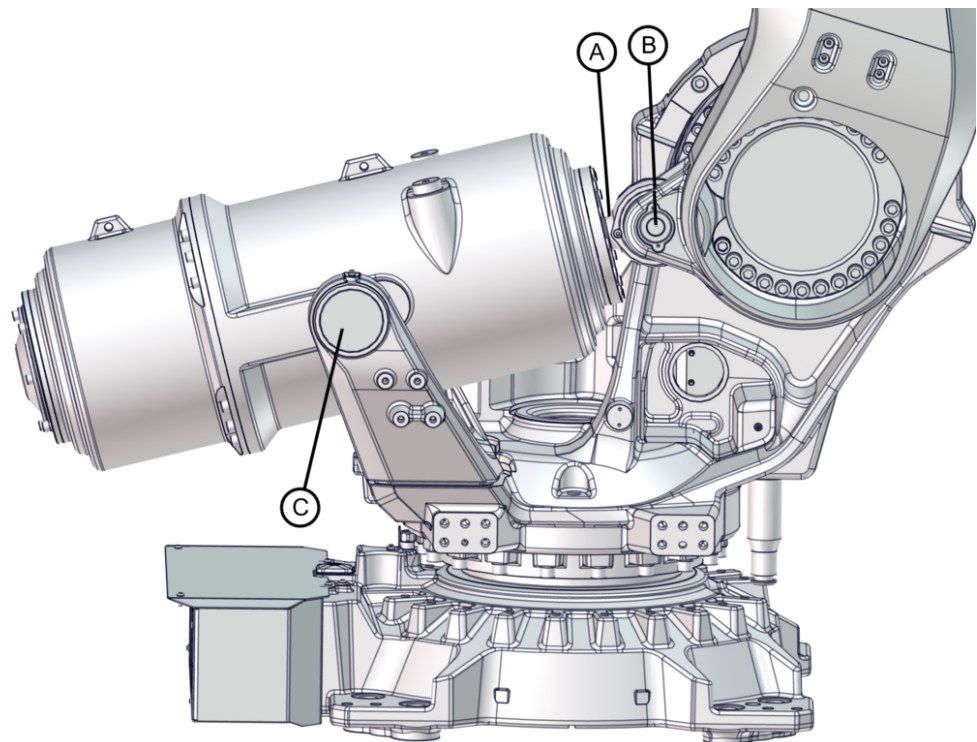

xx1600002052

A	Piston rod (inside balancing device)
B	Link ear
C	Rear attachments of the balancing device (rear bearing)

Required tools

Visual inspection, no tools are required.

Continues on next page

3 Maintenance

3.3.8 Inspecting the balancing device

Continued

Required material

Equipment	Article number	Note
Maintenance kit, link ear	3HAC062076-001	The maintenance kit contains: <ul style="list-style-type: none">• End cover• Radial sealing with dust lip, 50x68x8 (2 pcs)• O-ring 104.5• Spherical roller bearing• Washer
Maintenance kit, cradle	3HAC045822-001	Includes: <ul style="list-style-type: none">• bearings and seals• VK cover.

Check for dissonance

The check points are shown in the figure [Inspection points, balancing device on page 125](#).

	Check points	Action
1	Check for dissonance from the bearing at the link ear and the bearings at the rear attachments.	If dissonance is detected, perform maintenance according to maintenance kits and instructions in section Replacing the spherical roller bearing on page 403 and on page ? .
2	Check for dissonance from the balancing device (a tapping sound, caused by the springs inside the cylinder).	If dissonance is detected, replace the balancing device or consult ABB Service. How to replace the device is detailed in section Replacing the balancing device on page 417 . This section also specifies the spare part number.
3	Check for dissonance from the piston rod (squeaking may indicate worn plain bearings, internal contamination or insufficient lubrication).	If dissonance is detected, wipe clean the piston rod. If dissonance continues after the piston rod is cleaned, perform maintenance according to given instructions in <i>Maintenance kit, complete</i> .

Check for damage

Check for damage, such as scratches, general wear, uneven surfaces or incorrect positions.

The check points are shown in the figure [Inspection points, balancing device on page 125](#).

	Check points	Action
1	Check for damage on the part of the piston rod that is visible at the front of the balancing device.	If damage is detected, perform maintenance according to given instructions in <i>Maintenance kit, complete</i> .

Continues on next page

Check for leakage

Leaks at o-rings, radial sealings etc. are not acceptable and must be attended to immediately to avoid damage to the bearing.

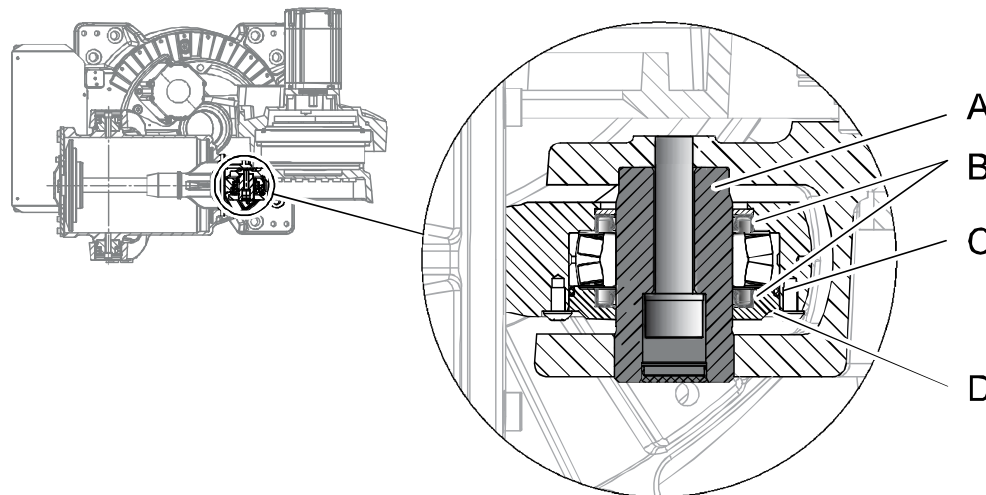

xx100000207

A	Shaft
B	Radial sealing with dust lip, 50x68x8 (2 pcs)
C	O-ring, 85x3
D	End cover

	Action	Note
1	Clean the area at the front ear from contamination.	
2	Run the robot for some minutes, in order to move the balancing device piston.	
3	 DANGER Turn off all: <ul style="list-style-type: none"> • electric power supply to the robot • hydraulic pressure supply to the robot • air pressure supply to the robot Before entering the robot working area.	
4	Check the area around the o-ring and radial sealings at the front ear, for leakage.	
5	Replace o-ring and radial sealings if leaks are detected.	The o-ring and radial sealings are included in the Maintenance kit, bearings and seals already assembled with sealing spacers and sealing rings. Article number for the kit is specified in Required material on page 126 . Replacement of the complete bearing is described in section Replacing the balancing device on page 417 .

Continues on next page

3 Maintenance

3.3.8 Inspecting the balancing device

Continued

Check for contamination / lack of free space

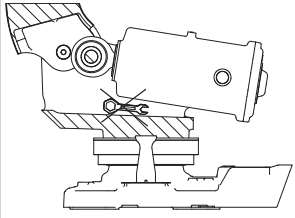
	Action	Note
1	 DANGER Turn off all: <ul style="list-style-type: none">• electric power supply to the robot• hydraulic pressure supply to the robot• air pressure supply to the robot Before entering the robot working area.	
2	Check that there are no obstacles inside the frame, that could prevent the balancing device from moving freely. Keep the areas around the balancing device clean and free from objects, such as service tools.	 xx1300000423

3.3.9 Inspecting the cable harness

Location of cable harness

The cable harness is located as shown in the figure.

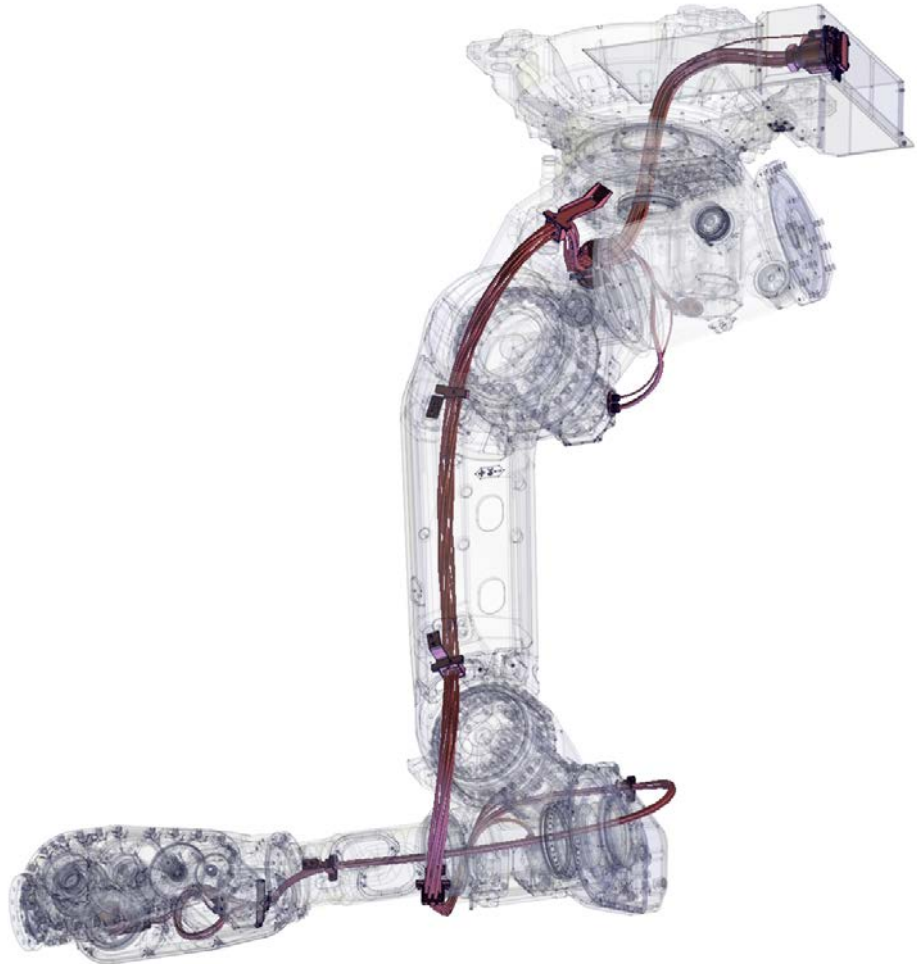

xx1600002063

Required tools

Visual inspection, no tools are needed.

Continues on next page



3 Maintenance

3.3.9 Inspecting the cable harness

Continued

Inspecting the cable harness

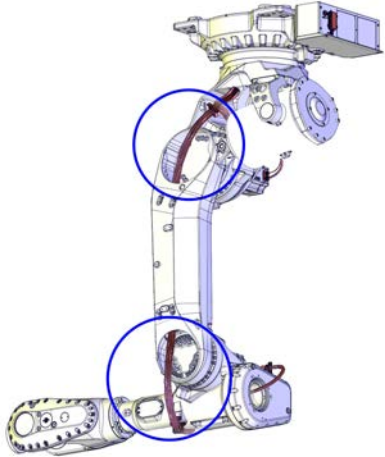
Use this procedure to inspect cable harness of axes 1-6.

	Action	Note
1	<p> DANGER</p> <p>Turn off all:</p> <ul style="list-style-type: none"> • electric power supply • hydraulic pressure supply • air pressure supply <p>to the robot, before entering the robot working area.</p>	
2	<p>Make an overall inspection of the cable harness in order to detect wear and damage.</p> <p>Pay special attention to the areas of axis-2 and axis-3 movement, shown in the figure. Make sure the cabling is not damaged between the cable brackets in these areas.</p>	 <p>xx1600002064</p>
3	<p>Check that all visible cable brackets and attachments are properly secured, by following the cable harness from the base to the wrist.</p>	
4	<p>Check that all visible velcro straps are properly secured.</p> <p> Note</p> <p>Replace if damaged.</p>	
5	<p>Check the motor cables visually for any damage.</p>	
6	<p>Check the connectors at the base visually for any damage.</p>	

Continues on next page

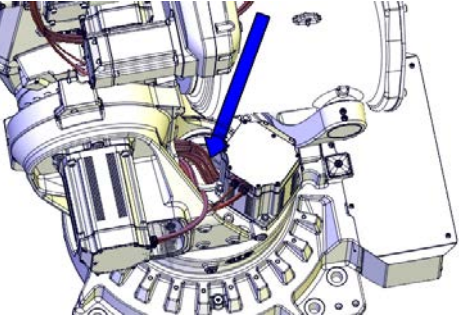
	Action	Note
7	<p>Check the cabling going through the protection tube, to detect possible cable chafing, by using your hands inside the tube to feel the cables. Ensure that the cables are undamaged.</p> <p>Remove any objects that may cause possible cable chafing.</p> <p>Replace damaged cabling, if any.</p>	 <p>xx1300001094</p>
8	<p>Replace the cable harness if wear, cracks or damage is detected.</p>	<p>See Removing the cable harness on page 217.</p>

3 Maintenance

3.3.10 Inspecting the information labels

3.3.10 Inspecting the information labels

Location of labels

These figures show the location of the information labels to be inspected. The symbols are described in section [Safety symbols on manipulator labels on page 21](#).

Illustration 1

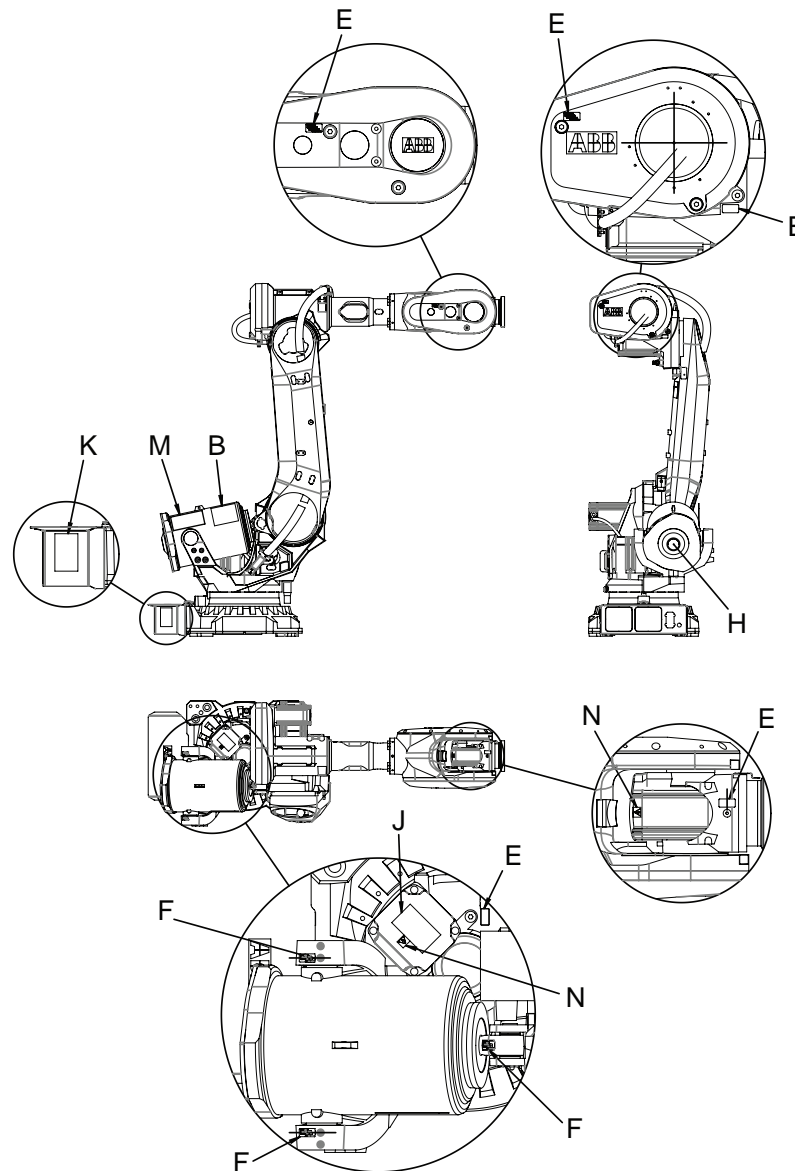

xx1300001093

Continues on next page

Illustration 2

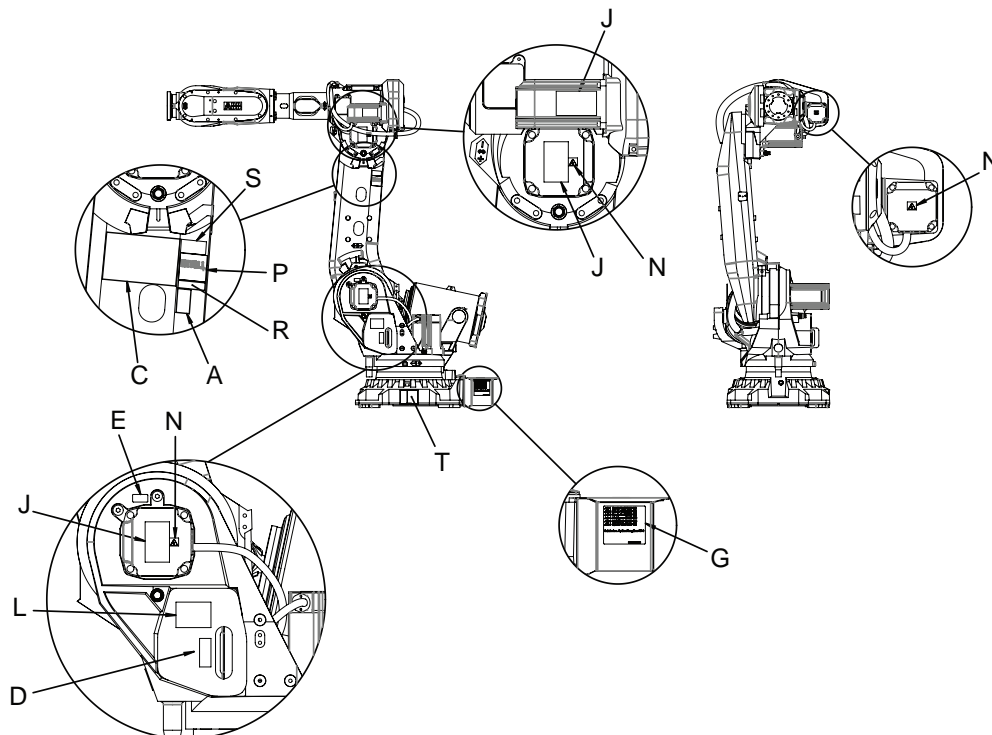

xx1300001085

Illustration 3

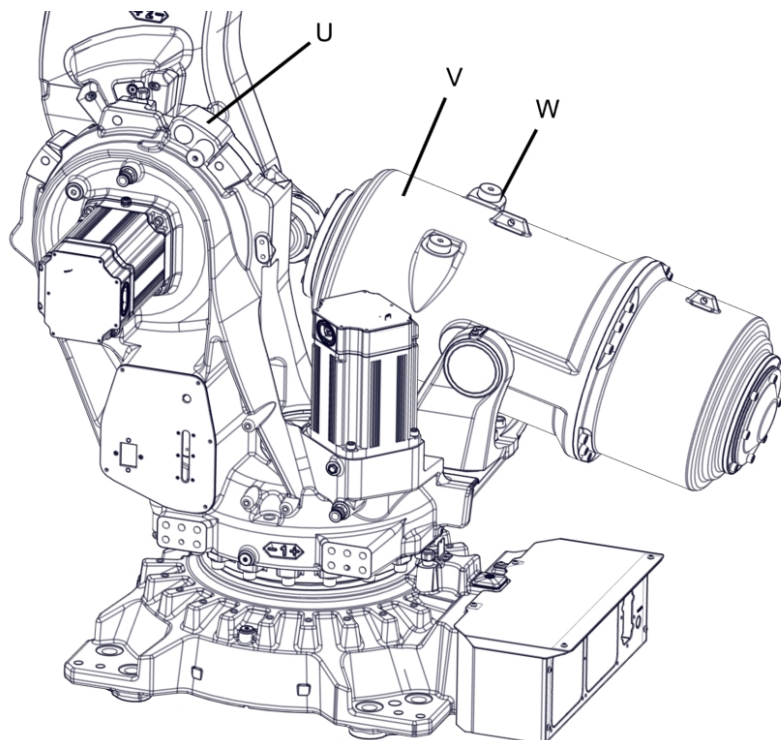

xx1600002059



Description	Illustration
-------------	--------------

Continues on next page

3 Maintenance

3.3.10 Inspecting the information labels

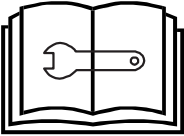
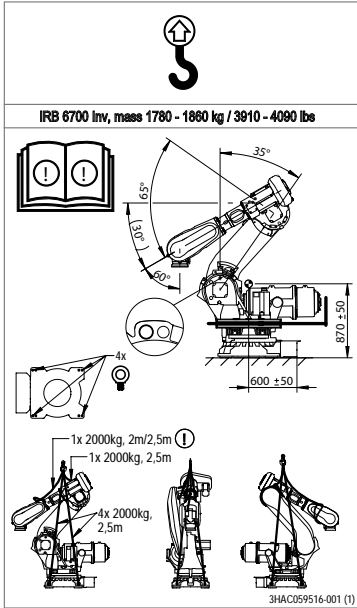
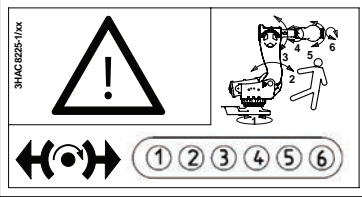
Continued

A	Calibration label	
B	Instruction label Before dismantling see product manual	 xx0900000816
C	Instruction label Lifting of robot	 IRB 6700 Inv, mass 1780 - 1860 kg / 3910 - 4080 lbs xx1600002055
D	Instruction label Brake release Moving robot Brake release buttons	 xx1300001083
E	Oil specification label	
F	Grease specification label	
G	Complete oil specification	
H	Warning label Do not dismantle Stored energy	 xx1300001086

Continues on next page

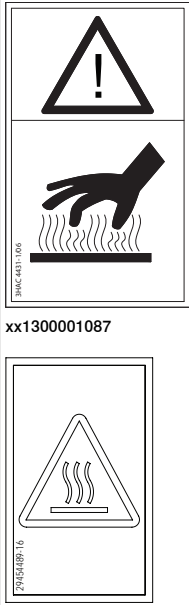
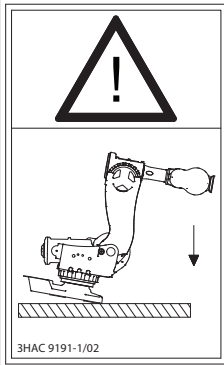
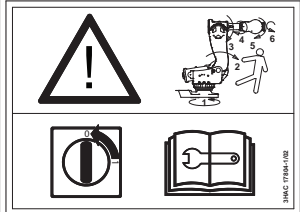
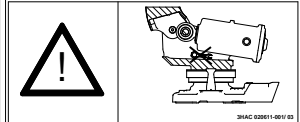
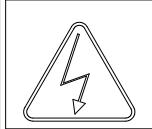
<p>J</p>	<p>Warning label Heat</p>	 <p>xx1300001087</p> <p>xx1700000984</p>
<p>K</p>	<p>Warning label Tip risk when loosening bolts</p>	 <p>xx1300001088</p>
<p>L</p>	<p>Warning label Moving robot Shut off with handle Before dismantling see product manual</p>	 <p>xx1300001089</p>
<p>M</p>	<p>Warning label Keep areas around the balancing device free from objects</p>	 <p>xx1300001090</p>
<p>N</p>	<p>Warning label Flash</p>	 <p>xx1300001091</p>
<p>P</p>	<p>Rating label</p>	

Continues on next page

3 Maintenance

3.3.10 Inspecting the information labels

Continued

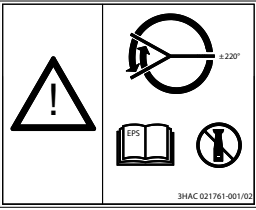
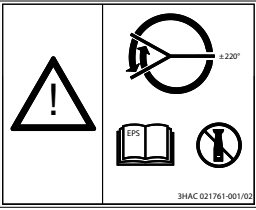
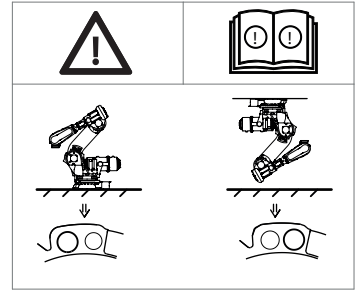
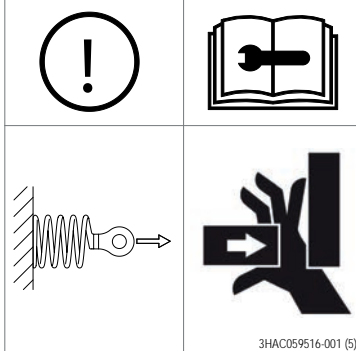
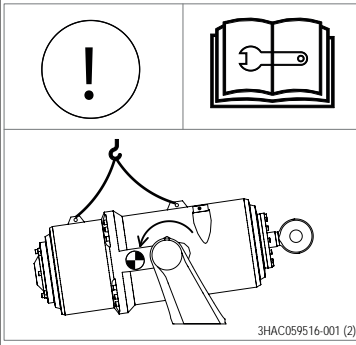
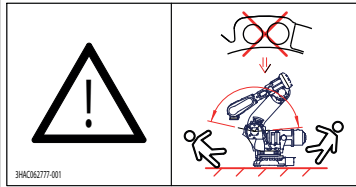
S	UL label	 <p>xx1300001092</p>
T	<p>Label</p> <p>Extended rotation</p> <p>No mechanical stop</p> <p>See user documentation</p>	 <p>xx1300001092</p>
U	<p>Warning label</p> <p>Use transportation lock screw when moving, transporting or rotating robot.</p> <p>See user documentation</p>	 <p>xx1600002053</p>
V	<p>Caution label</p> <p>Balancing device pressurized</p> <p>See user documentation</p>	 <p>xx1600002056</p>
W	<p>Caution label</p> <p>Center of gravity and lifting of balancing device</p> <p>Risk of squeezing</p> <p>See user documentation</p>	 <p>xx1600002060</p>
X	<p>Warning label</p> <p>The robot can move unexpectedly when floor standing.</p> <p>Always use transportation lock screw in floor standing position.</p>	 <p>xx1700000814</p>

Continues on next page

Required tools and equipment

Visual inspection, no tools are required.

Inspecting, labels

	Action	Note
1	 DANGER Turn off all: <ul style="list-style-type: none">• electric power supply• hydraulic pressure supply• air pressure supply to the robot, before entering the safeguarded space.	
2	Inspect the labels, located as shown in the figures.	
3	Replace any missing or damaged labels.	Article numbers for the labels and plate set is specified in Spare parts on page 731 .

3 Maintenance

3.3.11 Inspecting the transportation lock screw

3.3.11 Inspecting the transportation lock screw

Location of the transportation lock screw

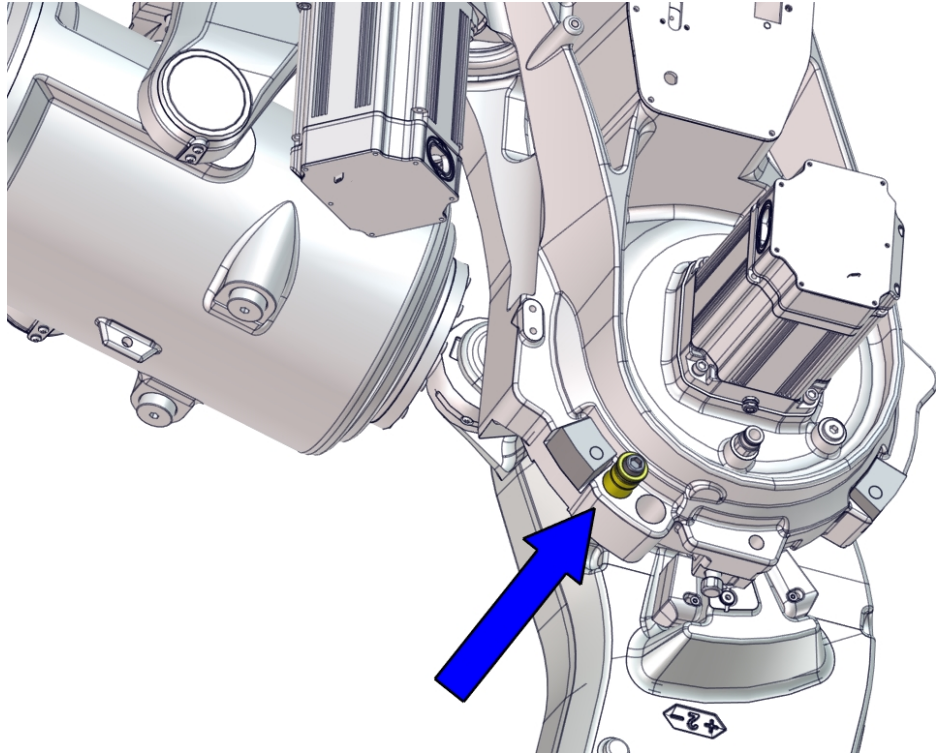

xx1600002008

Lift, transport and rotation of the robot

The robot arm system must always be locked in a secure position during lift, transport or rotation to inverted or standing position. This is done by locking the lower arm in position with a transportation lock screw. The transportation lock screw is stored at a parking position in the robot frame, when not used. This section describes how to move the screw to the locking position in order to secure the lower arm.

At delivery, the robot and the lower arm is already locked in the correct position with the transportation lock screw.



CAUTION

No tool is permitted to be fitted on the robot when it is lifted, transported or rotated.

Required tools

Equipment, etc.	Article number	Note
Standard toolkit	-	Content is defined in section Standard toolkit on page 724 .

Continues on next page

Inspecting the transportation lock screw for transport and rotation

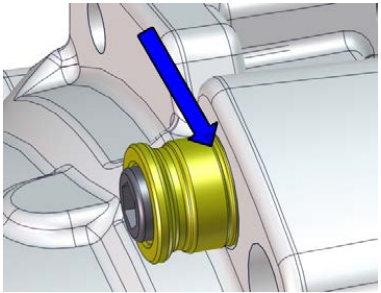
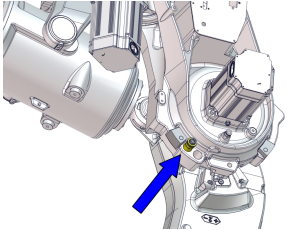
	Action	Note
1	 DANGER Turn off all: <ul style="list-style-type: none"> • electric power supply to the robot • hydraulic pressure supply to the robot • air pressure supply to the robot Before entering the robot working area.	
2	Remove any dirt from the hole in axis 2. The groove on the sleeve is supposed to be aligned with the frame in lifting, rotating and transportation position.	 xx1600002114
3	Make sure that there are no deformations or damage to the sleeve or the screw.	
4	Make sure that the screw and sleeve are in their correct position when lifting, rotating or transporting the robot.	
5	Check the tightening torque.	Tightening torque: 75 Nm±15 Nm
6	Always keep the transportation lock screw and sleeve in the parking position when not in use.	 xx1600002008

3 Maintenance

3.3.12 Inspecting the axis-1 mechanical stop pin

3.3.12 Inspecting the axis-1 mechanical stop pin

Location of mechanical stop pin

The axis-1 mechanical stop is located as shown in the figure.

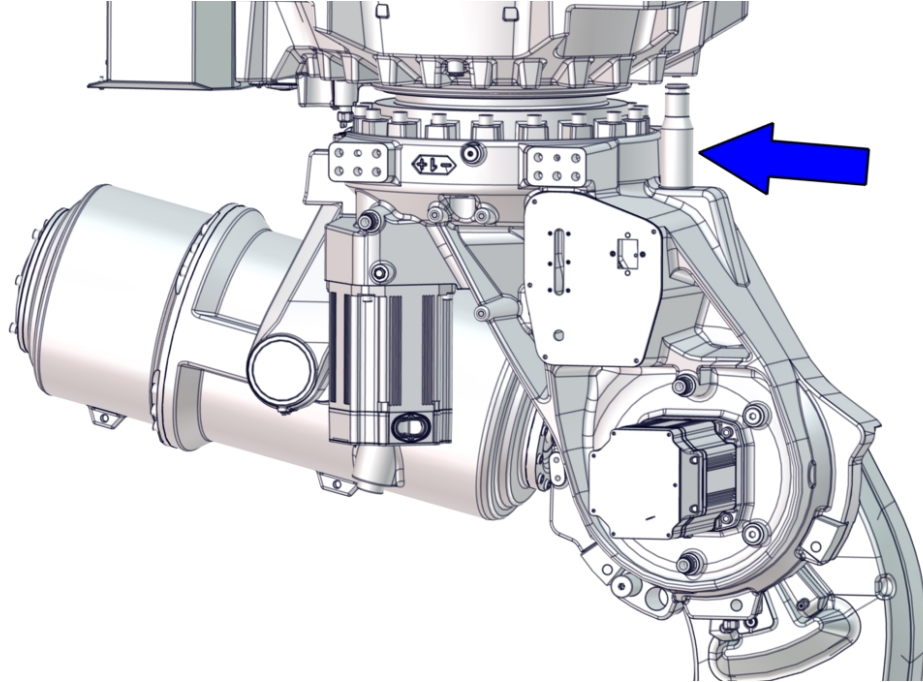



xx1600002065

Required equipment

Visual inspection, no tools are required.

Inspecting, mechanical stop pin

Use this procedure to inspect the axis-1 mechanical stop pin.

	Action	Note
1	 DANGER Turn off all: <ul style="list-style-type: none">• electric power supply• hydraulic pressure supply• air pressure supply to the robot, before entering the safeguarded space.	
2	Inspect the axis-1 mechanical stop pin. If the mechanical stop pin is bent or damaged, it must be replaced.  Note The expected life of gearboxes can be reduced after collision with the mechanical stop.	

3.3.13 Inspecting the additional mechanical stops

Location of mechanical stops

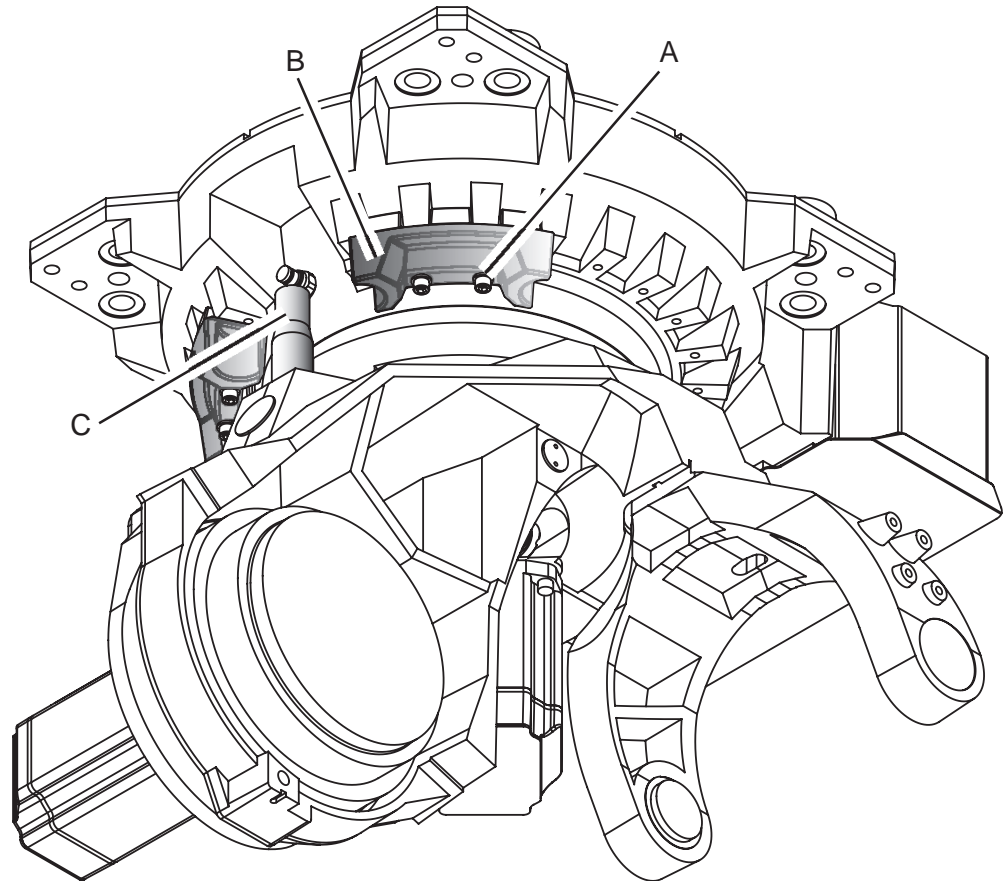

xx1600002066

A	Attachment screws M12x70 quality 12.9 Gleitmo 603 (2 pcs per additional mechanical stop)
B	Movable mechanical stop
C	Mechanical stop pin axis-1

Required equipment

Equipment etc.	Article number	Note
Movable mechanical stop axis 1	3HAC048533-003	Limits the robot working range by 15°. Includes attachment screws and an assembly drawing. <ul style="list-style-type: none"> • Mechanical stop • Attachment screws M12x70 stainless steel and washers stainless steel • Document for mechanical stop
Standard toolkit	-	Content is defined in section Standard toolkit on page 724 .

Continues on next page

3 Maintenance

3.3.13 Inspecting the additional mechanical stops

Continued

Inspecting, mechanical stops

Use this procedure to inspect the additional mechanical stops.

	Action	Note
1	 DANGER Turn off all: <ul style="list-style-type: none">• electric power supply• hydraulic pressure supply• air pressure supply to the robot, before entering the robot working area.	
2	Make sure no additional stops are damaged.	Shown in figure Location of mechanical stops on page 141 .
3	Make sure the stops are properly attached. Correct tightening torque, additional mechanical stops: <ul style="list-style-type: none">• Axis 1 = 60 Nm.	
4	If any damage is detected, the mechanical stops must be replaced. Correct attachment screws: <ul style="list-style-type: none">• M12x70 quality 12.9 Gleitmo 603 (2 pcs per additional mechanical stop)	Article number is specified in Required equipment on page 141 .

3.3.14 Inspecting the dampers

Location of dampers

The figure below shows the location of all the dampers to be inspected.

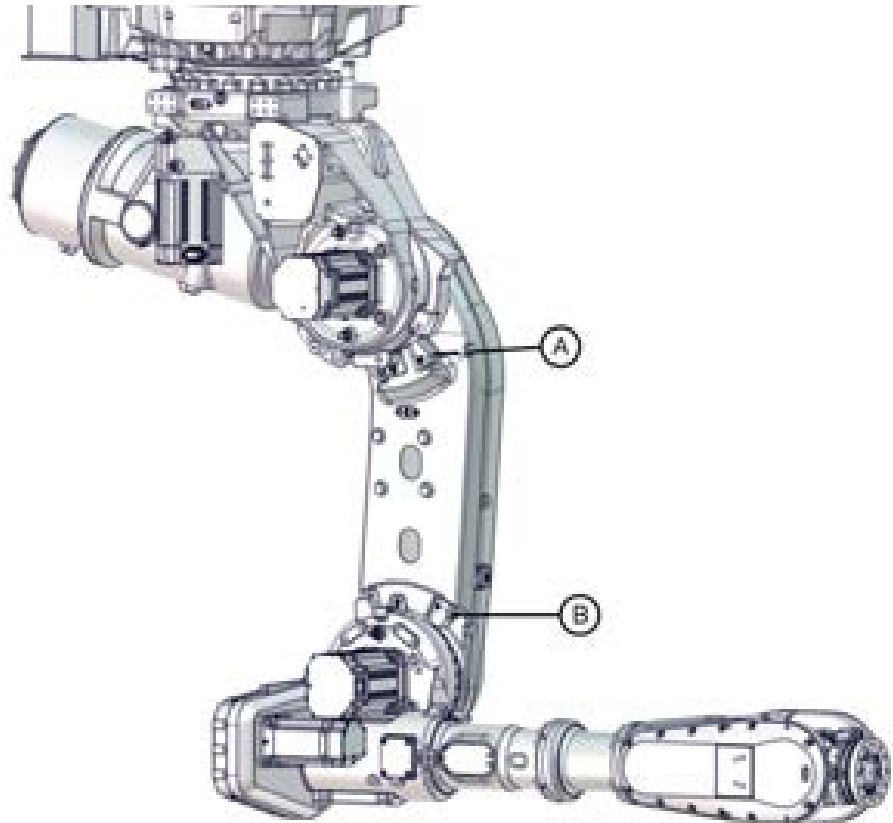

xx1600002067

A	Axis-2 damper, 2 pcs
B	Axis-3 damper, 2 pcs

Required equipment

Visual inspection, no tools are required.

Inspecting, dampers

The procedure below details how to inspect the dampers.



Note

A damaged damper must be replaced.

Continues on next page

3 Maintenance

3.3.14 Inspecting the dampers

Continued

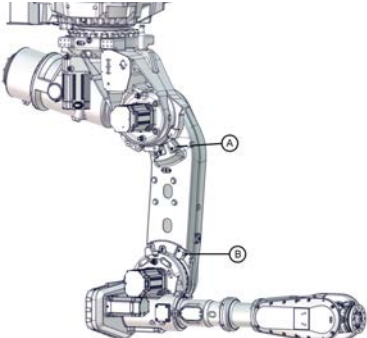
	Action	Note				
1	<p> DANGER</p> <p>Turn off all:</p> <ul style="list-style-type: none"> • electric power supply to the robot • hydraulic pressure supply to the robot • air pressure supply to the robot <p>Before entering the robot working area.</p>					
2	Check all dampers for damage, cracks or existing impressions larger than 1 mm.	 <p>xx1600002067</p> <table border="1" data-bbox="997 987 1406 1077"> <tr> <td data-bbox="997 987 1038 1032">A</td> <td data-bbox="1038 987 1406 1032">Axis-2 damper, 2 pcs</td> </tr> <tr> <td data-bbox="997 1032 1038 1077">B</td> <td data-bbox="1038 1032 1406 1077">Axis-3 damper, 2 pcs</td> </tr> </table>	A	Axis-2 damper, 2 pcs	B	Axis-3 damper, 2 pcs
A	Axis-2 damper, 2 pcs					
B	Axis-3 damper, 2 pcs					
3	Check attachment screws for deformation.	<p>If any damage is detected, the damper must be replaced with a new one.</p> <p>Attachment screws: M6x60.</p> <p>Locking liquid: Loctite 243.</p> <p>Spare part number is found in <i>Product manual, spare parts - IRB 6700/IRB 6700Inv.</i></p>				

3.3.15 Inspecting the signal lamp (option)

Location of signal lamp

The signal lamp is located as shown in this figure.

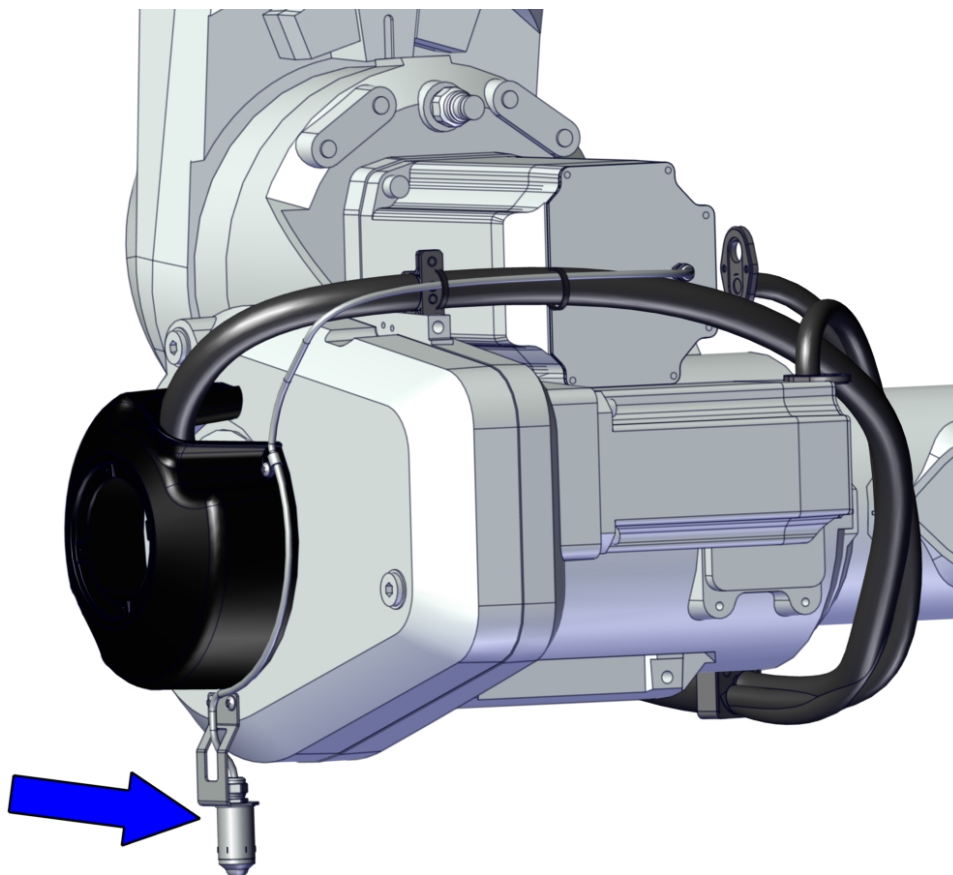

xx1600002090

Required tools and equipment

Equipment	Article number	Note
Signal lamp kit	See Spare parts on page 731 .	To be replaced if damage is detected.
Standard toolkit	-	Content is defined in section Standard toolkit on page 724 .

Inspecting, signal lamp

Use this procedure to inspect the function of the signal lamp.

	Action	Note
1	Inspect that signal lamp is lit when motors are put in operation ("MOTORS ON").	

Continues on next page

3 Maintenance

3.3.15 Inspecting the signal lamp (option)

Continued

	Action	Note
2	 DANGER Turn off all: <ul style="list-style-type: none">• electric power supply• hydraulic pressure supply• air pressure supply to the robot, before entering the safeguarded space.	
3	If the lamp is not lit, trace the fault by: <ul style="list-style-type: none">• inspecting whether the signal lamp is broken. If so, replace it.• inspecting cable connections.• measuring the voltage in the connectors of motor axis 3 (=24V).• inspecting the cabling. Replace the cabling if a fault is detected.	Article number is specified in Required tools and equipment on page 145 .

3.4 Replacement/changing activities

3.4.1 Type of lubrication in gearboxes

Introduction

This section describes where to find information about the type of lubrication, article number and the amount of lubrication in the specific gearbox. It also describes the equipment needed when working with lubrication.

Type and amount of oil in gearboxes

Information about the type of lubrication, article number as well as the amount in the specific gearbox can be found in *Technical reference manual - Lubrication in gearboxes* available for registered users on myABB Business Portal, www.abb.com/myABB.

Continues on next page

3 Maintenance

3.4.1 Type of lubrication in gearboxes

Continued

Location of gearboxes

The figure shows the location of the gearboxes.

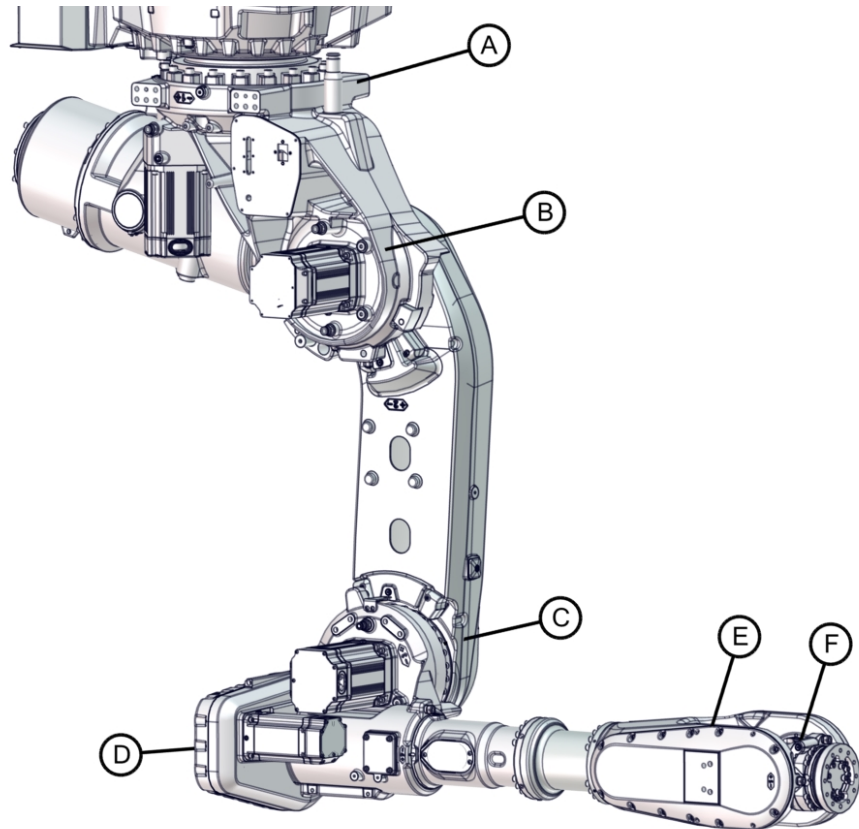

xx1600002100

A	Gearbox, axis 1
B	Gearbox, axis 2
C	Gearbox, axis 3
D	Gearbox, axis 4
E	Gearbox, axis 5
F	Gearbox, axis 6

Equipment

Equipment	Note
Oil dispenser	Includes pump with outlet pipe. Use the suggested dispenser or a similar one: <ul style="list-style-type: none">Orion OriCan article number 22590 (pneumatic)
Nipple for quick connect fitting, with o-ring	
Oil level gauge	Assemble the extender to be able to use the oil level gauge when the fork lift accessories are mounted. The tool also includes an air vent.

3.4.2 Changing oil, axis-1 gearbox

Two alternative ways of draining the oil

There are two alternatives for draining the oil on an IRB 6700Inv, inverted or floor standing. The first section below describes inverted oil drainage and the second floor standing oil drainage.



CAUTION

Because of the risk of getting air bubbles into axis-1 gear in inverted position, it is recommended to let the oil be circulated through the gear, and not drained.

Usage of oil dispenser

The oil change procedure in this section describes usage of an oil dispenser.

Location of oil plugs

The oil plugs of the gearbox is located as shown in the figure.

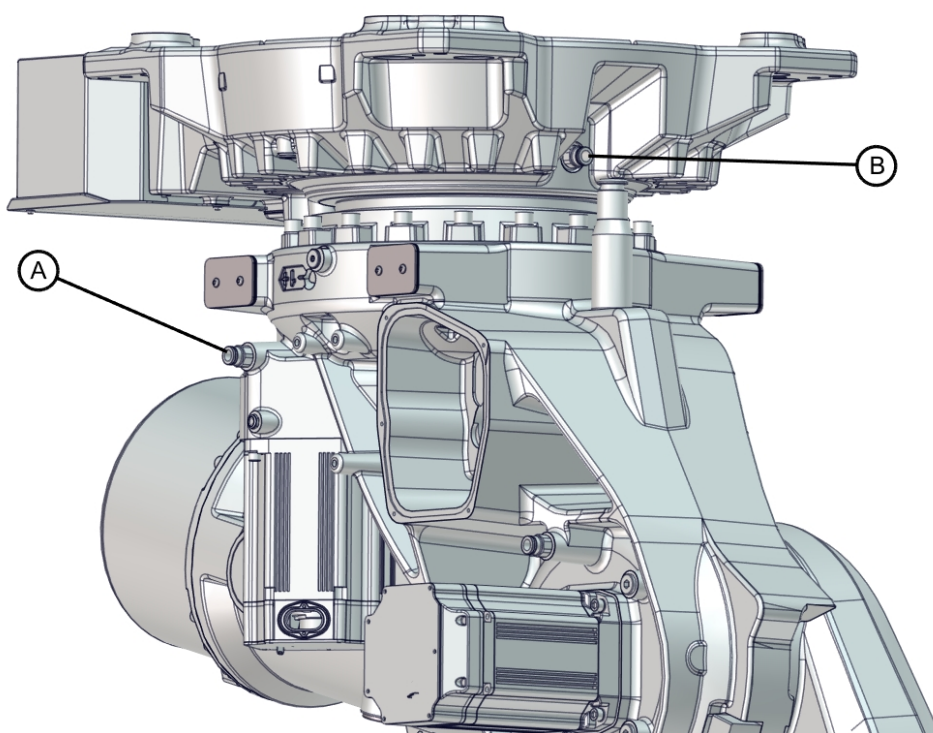

xx1600002030

A, B	Oil plug, Tightening torque: 24 Nm Used for both filling, ventilation and level measurement.
------	---

Continues on next page

3 Maintenance

3.4.2 Changing oil, axis-1 gearbox

Continued

Required tools and equipment

Equipment, etc.	Article number	Note
Oil collecting vessel	-	The capacity of the vessel must be sufficient to take the complete amount of oil.
Oil dispenser	-	One example of oil dispenser can be found in section Type of lubrication in gearboxes on page 147 .
Oil level gauge	3HAC061881-001	Assemble the extender to be able to use the oil level gauge when the fork lift accessories are mounted. The tool also includes an air vent.
Standard toolkit	-	Content is defined in section Standard toolkit on page 724 .

Required consumables and wear parts

Material		Note
Lubricating oil		Information about the oil is found in <i>Technical reference manual - Lubrication in gearboxes</i> . See Type and amount of oil in gearboxes on page 147 .
Floor-standing manipulator O-ring, G 1/2"	3HAC061327-059	Used on oil plug. Always replace when refitting oil plug.

Required documents

Document name	Document number	Note
<i>Technical reference manual - Lubrication in gearboxes</i>	3HAC042927-001	

Circulate the oil in the axis-1 gearbox inverted







CAUTION

Because of the risk of getting air bubbles into axis-1 gear in inverted position, it is recommended to let the oil be circulated through the gear, and not drained.

	Action	Note
1	DANGER Turn off all: <ul style="list-style-type: none"> • electric power supply • hydraulic pressure supply • air pressure supply to the robot, before entering the robot working area.	

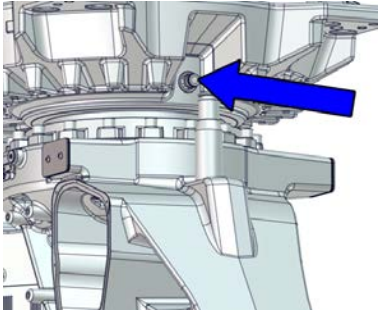
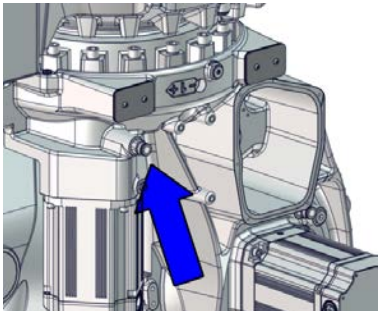
Continues on next page

	Action	Note
2	 WARNING Handling gearbox oil involves several safety risks, see Gearbox lubricants (oil or grease) on page 33 .	
3	Make sure that the oil temperature is $+25^{\circ}\text{C} \pm 10^{\circ}\text{C}$.  CAUTION The gearbox can contain an <i>excess pressure</i> that can be hazardous. Open the oil plug carefully in order to let the excess pressure out.	
4	Remove the protective cap on the upper oil plug. Install the oil collecting vessel on the upper oil plug.	 <p>xx1700001271</p>
5	Remove the protective cap on the lower oil plug. Connect the oil dispenser to the oil plug.	 <p>xx1700001272</p>
6	Press in new oil to be circulated with the old oil, with the oil dispenser.	Approximately 5 l.
7	Remove the oil dispenser and oil collecting vessel. Refit the protective cap on the oil plug.	
8	 Note After all repair and maintenance work involving oil, always wipe the robot clean from all surplus oil.	
9	 DANGER Make sure all safety requirements are met when performing the first test run. See Test run after installation, maintenance, or repair on page 97 .	

Continues on next page

3 Maintenance

3.4.2 Changing oil, axis-1 gearbox



Continued

Draining and filling oil into the axis-1 gearbox floor-standing



If the robot has been taken down to floor standing, for example due to axis-1 gearbox replacement, the gearbox is drained and filled when the robot is floor standing.

Draining the axis-1 gearbox floor-standing

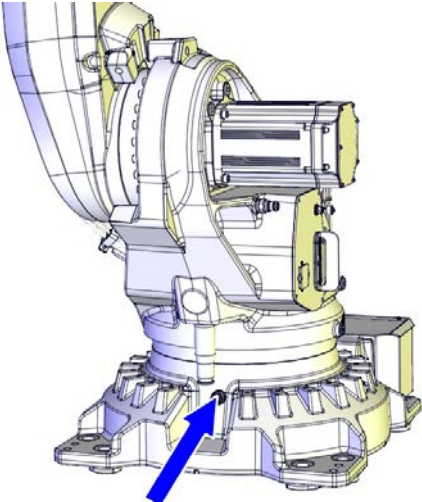
Use this procedure to drain the gearbox.

	Action	Note
1	 DANGER Turn off all: <ul style="list-style-type: none"> • electric power supply • hydraulic pressure supply • air pressure supply to the robot, before entering the safe-guarded space.	
2	 WARNING Handling gearbox oil involves several safety risks, see Gearbox lubricants (oil or grease) on page 33 .	
3	 CAUTION The gearbox can contain an <i>excess of pressure</i> that can be hazardous. Open the oil plug carefully in order to let the excess pressure out.	
4	Remove the protective cap from the nipple of the oil hole and connect the oil dispenser.	 <p>xx1200000948</p>

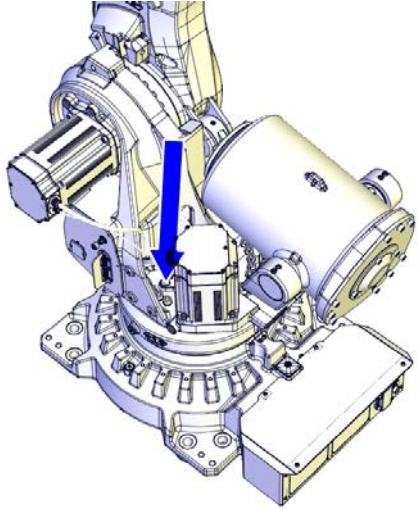
Continues on next page

	Action	Note
5	<p>Remove the plug from the vent hole.</p> <p> WARNING</p> <p>Open the vent hole while using the dispenser, to avoid damaging vital parts in the gear.</p>	 <p>xx1200000950</p>
6	<p>Suck out the oil with the oil dispenser.</p> <p> Note</p> <p>There will be some oil left in the gear after draining.</p>	
7	<p> WARNING</p> <p>Used oil is hazardous material and must be disposed of in a safe way. See section Decommissioning on page 711 for more information.</p>	
8	<p>Remove the oil dispenser.</p> <p>Refit the protective cap on the nipple.</p>	
9	<p>Refit the vent hole oil plug with a new o-ring.</p>	<p>O-ring, G 1/2": 3HAC061327-059 Tightening torque: 24 Nm.</p>

Filling axis-1 gearbox with oil floor-standing

Use this procedure to refill the gearbox with oil.





	Action	Note
1	<p> DANGER</p> <p>Turn off all:</p> <ul style="list-style-type: none"> • electric power supply • hydraulic pressure supply • air pressure supply <p>to the robot, before entering the safe-guarded space.</p>	

Continues on next page

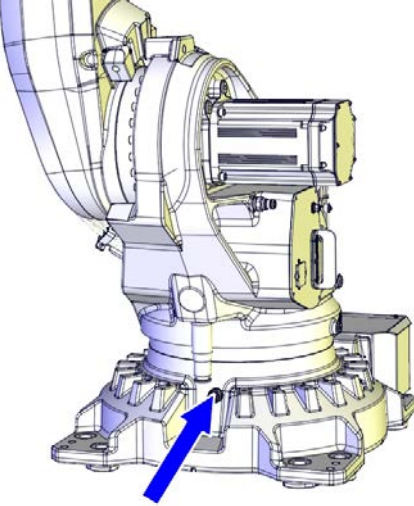

3 Maintenance

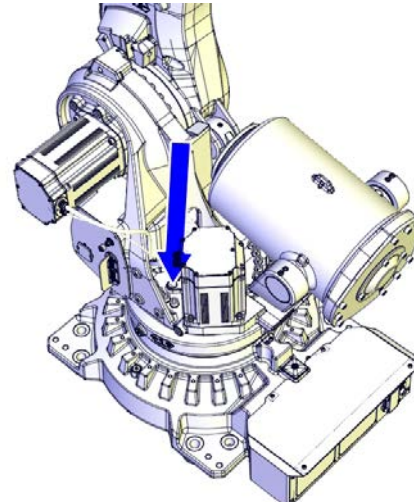
3.4.2 Changing oil, axis-1 gearbox

Continued

	Action	Note
2	<p> WARNING</p> <p>Handling gearbox oil involves several safety risks, see Gearbox lubricants (oil or grease) on page 33.</p>	
3	<p>Remove the protective cap from the nipple of the oil hole and connect the oil dispenser.</p>	 <p>xx120000948</p>
4	<p>Remove the plug from the vent hole.</p> <p> Note</p> <p>The vent hole is opened to let out air during the filling process.</p>	 <p>xx120000950</p>
5	<p>Refill the gearbox with oil with the oil dispenser.</p> <p> Note</p> <p>The amount of oil to be filled depends on the amount previously being drained.</p>	<p>Type of oil and total amount is detailed in <i>Technical reference manual - Lubrication in gearboxes</i>.</p>

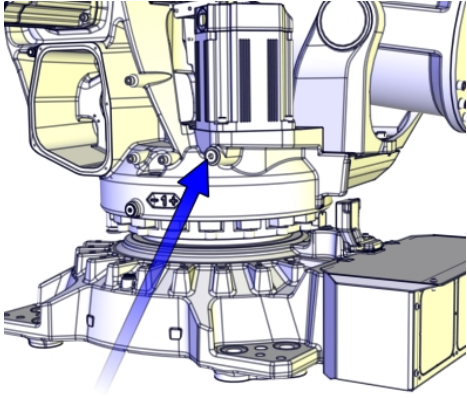
Continues on next page

	Action	Note
6	Inspect the oil level.	 <p data-bbox="970 728 1082 750">xx1500001655</p> <p data-bbox="970 766 1337 831">Required oil level: 0 - 5 mm below the oil plug hole.</p>
7	Remove the oil dispenser and refit the protective cap to the nipple.	
8	Refit the vent hole oil plug with a new o-ring.	O-ring, G 1/2": 3HAC061327-059 Tightening torque: 24 Nm.
9	 Note After all repair and maintenance work involving oil, always wipe the robot clean from all surplus oil. The robot color can otherwise be discolored.	
10	 DANGER Make sure all safety requirements are met when performing the first test run. See Test run after installation, maintenance, or repair on page 97 .	

3 Maintenance

3.4.3 Changing oil, axis-2 gearbox

3.4.3 Changing oil, axis-2 gearbox

Usage of oil dispenser

The oil change procedure in this section describes usage of an oil dispenser.

Location of oil plugs

The oil plugs of the gearbox are located as shown in the figure.

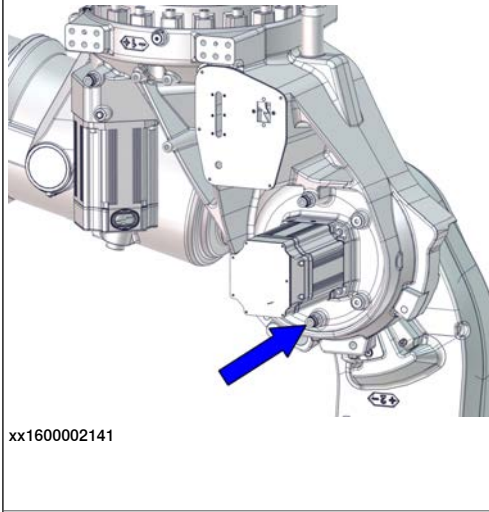
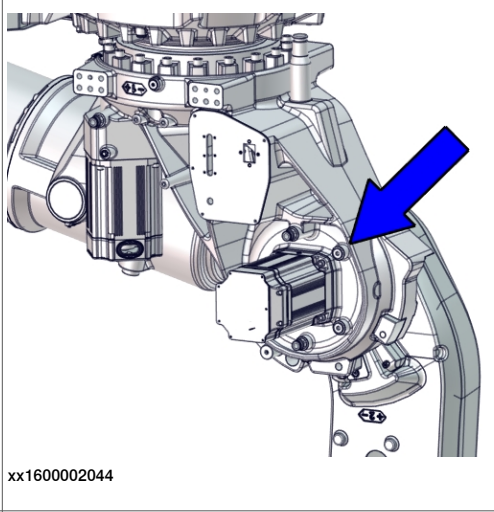
	
<p>Oil hole with nipple Used for both draining and filling with an oil dispenser.</p>	<p>Vent hole plug/level plug</p>
<p>Tightening torque: N/A.</p>	<p>Tightening torque: 24 Nm.</p>

Required tools and equipment

Equipment, etc.	Article number	Note
Oil collecting vessel	-	The capacity of the vessel must be sufficient to take the complete amount of oil.
Oil dispenser	-	One example of oil dispenser can be found in section Type of lubrication in gearboxes on page 147 .
Standard toolkit	-	Content is defined in section Standard toolkit on page 724 .

Required consumables and wear parts

Consumables	Article number	Note
Lubricating oil	-	Information about the oil is found in <i>Technical reference manual - Lubrication in gearboxes</i> .
O-ring, G 1/2"	3HAC061327-059	Used on oil plug. Always replace when refitting oil plug.



Continues on next page

Required documents

Document name	Document number	Note
<i>Technical reference manual - Lubrication in gearboxes</i>	3HAC042927-001	

Draining the axis-2 gearbox

Use this procedure to drain the gearbox.

	Action	Note
1	 DANGER Turn off all: <ul style="list-style-type: none"> • electric power supply • hydraulic pressure supply • air pressure supply to the robot, before entering the safe-guarded space.	
2	 WARNING Handling gearbox oil involves several safety risks, see Gearbox lubricants (oil or grease) on page 33 .	
3	 CAUTION The gearbox can contain an <i>excess pressure</i> that can be hazardous. Open the oil plug carefully in order to let the excess pressure out.	

Continues on next page



3 Maintenance

3.4.3 Changing oil, axis-2 gearbox

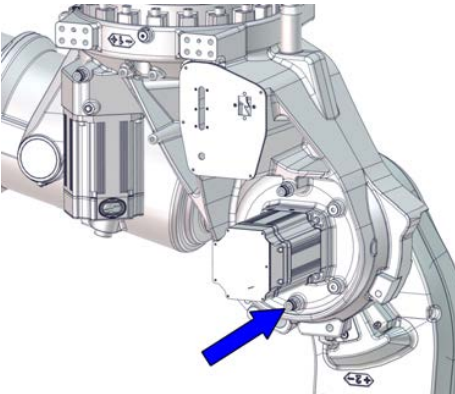
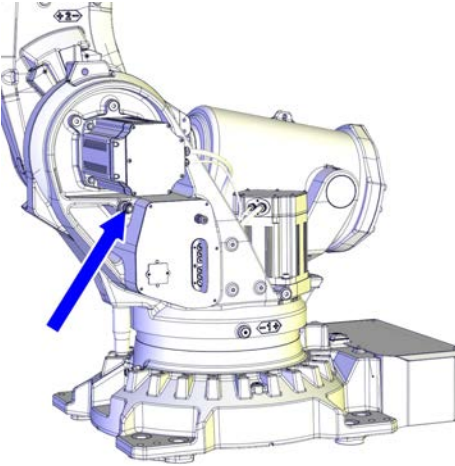
Continued

	Action	Note
4	Remove the protective cap from the nipple of the oil hole and connect the oil dispenser.	 <p data-bbox="943 707 1050 725">xx160002141</p> <p data-bbox="943 745 1406 853">If the robot has been taken down to floor standing, for example due to axis-2 gearbox replacement, refer to the below figure instead.</p>  <p data-bbox="943 1326 1050 1344">xx120000951</p>

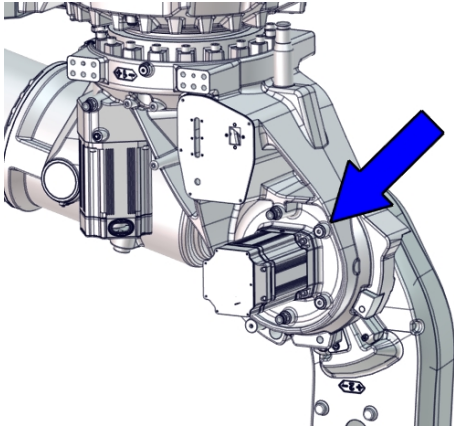
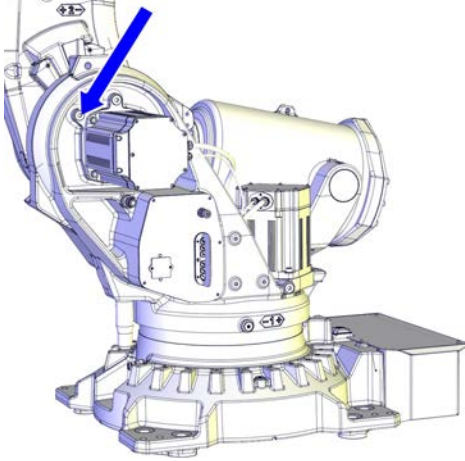
Continues on next page

	Action	Note
5	<p>Remove the plug from the vent hole.</p> <p> WARNING</p> <p>Open the vent hole while using the dispenser, to avoid damaging vital parts in the gear.</p>	 <p>xx1600002044</p> <p>If the robot has been taken down to floor standing, for example due to axis-2 gearbox replacement, refer to the below figure instead.</p>  <p>xx1200000952</p>
6	<p>Suck out the oil with the oil dispenser.</p> <p> Note</p> <p>There will be some oil left in the gear after draining.</p>	
7	<p> WARNING</p> <p>Used oil is hazardous material and must be disposed of in a safe way. See section Decommissioning on page 711 for more information.</p>	

Continues on next page

3 Maintenance



3.4.3 Changing oil, axis-2 gearbox

Continued



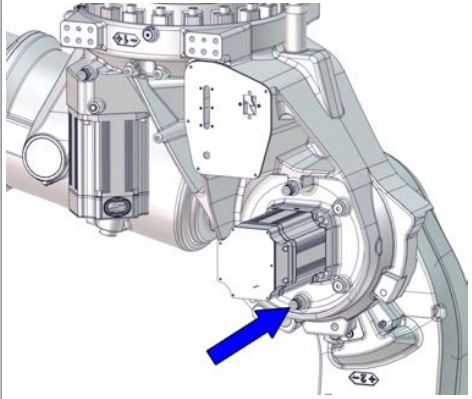

	Action	Note
8	Refill oil or: <ol style="list-style-type: none"> 1 Remove the oil dispenser 2 Refit the protective cap on the nipple. 3 Refit the vent hole oil plug with a new o-ring. 	O-ring, G 1/2": 3HAC061327-059 Vent hole plug, tightening torque: 24 Nm.

Filling oil into the axis-2 gearbox

Use this procedure to refill the gearbox with oil.

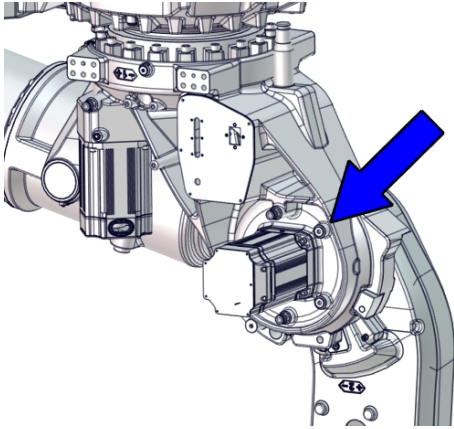
	Action	Note
1	 DANGER Turn off all: <ul style="list-style-type: none"> • electric power supply • hydraulic pressure supply • air pressure supply to the robot, before entering the safe-guarded space.	
2	 WARNING Handling gearbox oil involves several safety risks, see Gearbox lubricants (oil or grease) on page 33 .	
3	Remove the protective cap from the nipple of the oil hole and connect the oil dispenser.	 xx1600002141

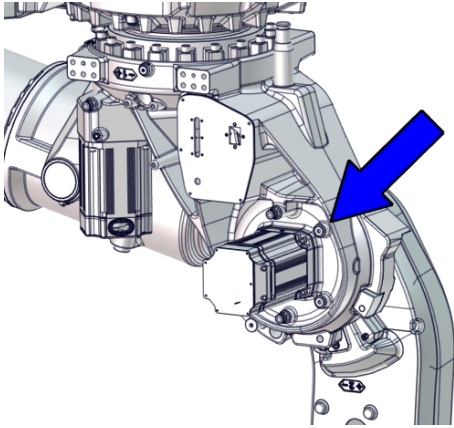
Continues on next page

	Action	Note
4	<p>Remove the plug from the vent hole.</p> <p> Note</p> <p>The vent hole is opened to let air out during the filling process.</p>	 <p>xx1600002044</p>
5	<p>Refill the gearbox with oil.</p> <p> Note</p> <p>The amount of oil to be filled depends on the amount previously being drained.</p>	<p>Type of oil and total amount is detailed in <i>Technical reference manual - Lubrication in gearboxes</i>.</p>
6	<p>Inspect the oil level at the vent hole (level plug).</p>	 <p>xx1600002044</p> <p>Required oil level is: 0-15 mm below the oil plug hole.</p> <p>More information is found in Inspecting the oil level in axis-2 gearbox on page 112.</p>
7	<p>Remove the oil dispenser. Refit the protective cap on the nipple.</p>	
8	<p>Refit the vent hole oil plug with a new o-ring.</p>	<p>O-ring, G 1/2": 3HAC061327-059 Tightening torque: 24 Nm.</p>
9	<p> DANGER</p> <p>Make sure all safety requirements are met when performing the first test run. See Test run after installation, maintenance, or repair on page 97.</p>	

3 Maintenance

3.4.4 Changing oil, axis-3 gearbox

3.4.4 Changing oil, axis-3 gearbox

Usage of oil dispenser

The oil change procedure in this section describes usage of an oil dispenser.

Location of oil plugs

The oil plugs of the gearbox are located as shown in the figure.

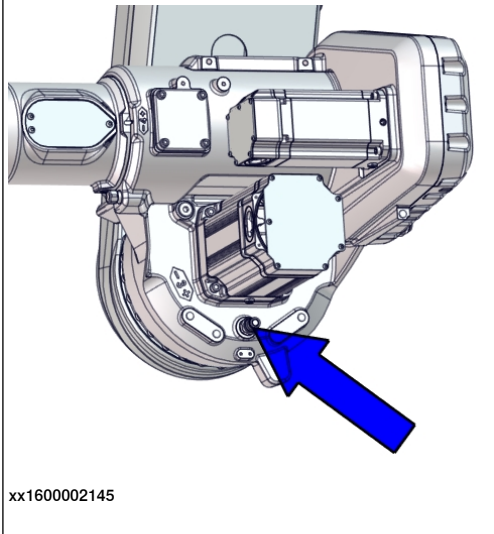
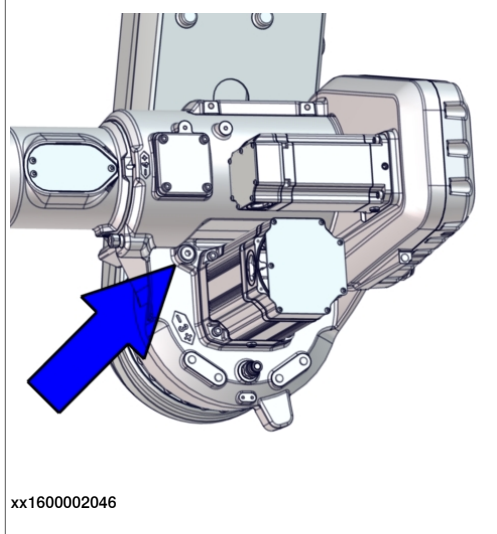
 <p>xx1600002145</p>	 <p>xx1600002046</p>
<p>Oil hole with nipple Used for both draining and filling with an oil dispenser.</p>	<p>Level/vent plug</p>
<p>Tightening torque: 24 Nm.</p>	<p>Tightening torque: 24 Nm.</p>

Required tools and equipment

Equipment, etc.	Article number	Note
Oil collecting vessel	-	The capacity of the vessel must be sufficient to take the complete amount of oil.
Oil dispenser	-	One example of oil dispenser can be found in section Type of lubrication in gearboxes on page 147 .
Standard toolkit	-	Content is defined in section Standard toolkit on page 724 .

Required consumables and wear parts

Consumables	Article number	Note
Lubricating oil	-	Information about the oil is found in <i>Technical reference manual - Lubrication in gearboxes</i> .
O-ring, G 1/2"	3HAC061327-059	Used on oil plug. Always replace when refitting oil plug.



Continues on next page

Required documents

Document name	Document number	Note
Technical reference manual - Lubrication in gearboxes	3HAC042927-001	

Draining the axis-3 gearbox

Use this procedure to drain the gearbox.

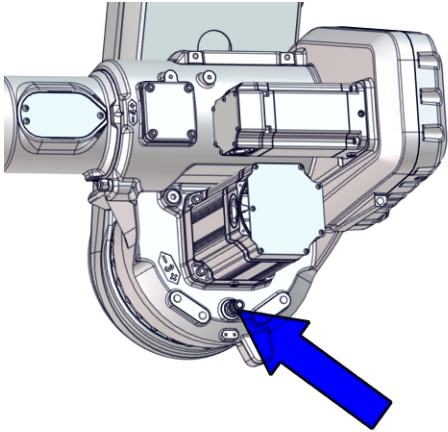

	Action	Note
1	Jog axis-3 to position: -180° (horizontal).	
2	 DANGER Turn off all: <ul style="list-style-type: none"> • electric power supply • hydraulic pressure supply • air pressure supply to the robot, before entering the safe-guarded space.	
3	 WARNING Handling gearbox oil involves several safety risks, see Gearbox lubricants (oil or grease) on page 33 .	
4	 CAUTION The gearbox can contain an <i>excess pressure</i> that can be hazardous. Open the oil plug carefully in order to let the excess pressure out.	
5	Remove the protective cap from the nipple of the oil hole and connect the oil dispenser.	 <p>xx1600002145</p>

Continues on next page

3 Maintenance

3.4.4 Changing oil, axis-3 gearbox

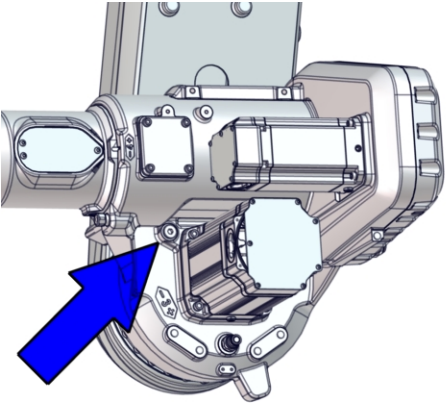
Continued







	Action	Note
6	<p>Remove the plug from the vent hole.</p> <p> WARNING</p> <p>Open the vent hole while using the dispenser, to avoid damaging vital parts in the gear.</p>	 <p>xx1600002046</p>
7	<p>Suck out the oil with the oil dispenser.</p> <p> Note</p> <p>There will be some oil left in the gear after draining.</p>	
8	<p> WARNING</p> <p>Used oil is hazardous material and must be disposed of in a safe way. See Decommissioning on page 711 for more information.</p>	
9	<p>Remove the oil dispenser.</p> <p>Refit the protective cap on the nipple.</p>	
10	<p>Refit the vent hole oil plug with a new o-ring.</p>	<p>O-ring, G 1/2": 3HAC061327-059 Tightening torque: 24 Nm.</p>

Filling oil into the axis-3 gearbox

Use this procedure to refill the gearbox with oil.

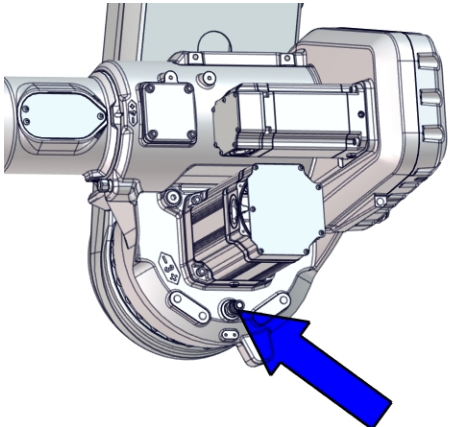
	Action	Note
1	<p>Jog the robot into position:</p> <ul style="list-style-type: none"> • Axis 1: • Axis 2: 0° • Axis 3: 180° (horizontal) • Axis 4: • Axis 5: • Axis 6: no significance 	

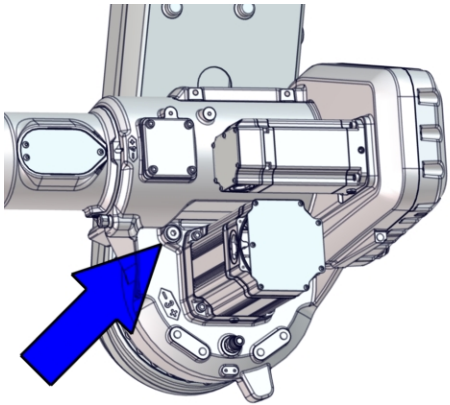
Continues on next page



	Action	Note
2	<p> DANGER</p> <p>Turn off all:</p> <ul style="list-style-type: none"> • electric power supply • hydraulic pressure supply • air pressure supply <p>to the robot, before entering the safe-guarded space.</p>	
3	<p> WARNING</p> <p>Handling gearbox oil involves several safety risks, see Gearbox lubricants (oil or grease) on page 33.</p>	
4	<p>Remove the protective cap from the nipple of the oil hole and connect the oil dispenser.</p>	 <p>xx1600002145</p>
5	<p>Remove the plug from the vent hole.</p> <p> Note</p> <p>The vent hole is opened to let air out during the filling process.</p>	 <p>xx1600002046</p>
6	<p>Refill the gearbox with oil.</p> <p> Note</p> <p>The amount of oil to be filled depends on the amount previously being drained.</p>	<p>Type of oil and total amount is detailed in <i>Technical reference manual - Lubrication in gearboxes</i>.</p>

Continues on next page

3 Maintenance

3.4.4 Changing oil, axis-3 gearbox

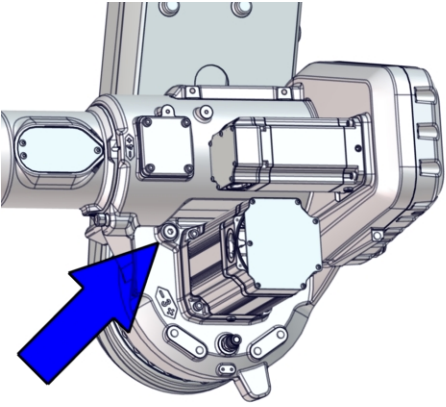
Continued

	Action	Note
7	Inspect the oil level at the vent hole (level plug).	 <p data-bbox="943 775 1050 792">xx1600002046</p> <p data-bbox="943 813 1401 869">Required oil level is: 0 - 20 mm below the oil plug hole.</p> <p data-bbox="943 875 1406 931">More information is found in Inspecting the oil level in axis-3 gearbox on page 114.</p>
8	Remove the oil dispenser. Refit the protective cap on the nipple.	
9	Refit the vent hole oil plug with a new o-ring.	O-ring, G 1/2": 3HAC061327-059 Tightening torque: 24 Nm.
10	 <p data-bbox="560 1133 667 1160">DANGER</p> <p data-bbox="464 1196 933 1301">Make sure all safety requirements are met when performing the first test run. See Test run after installation, maintenance, or repair on page 97.</p>	

3.4.5 Changing oil, axis-4 gearbox

Location of oil plugs

The oil plugs of the gearbox are located as shown in the figure.

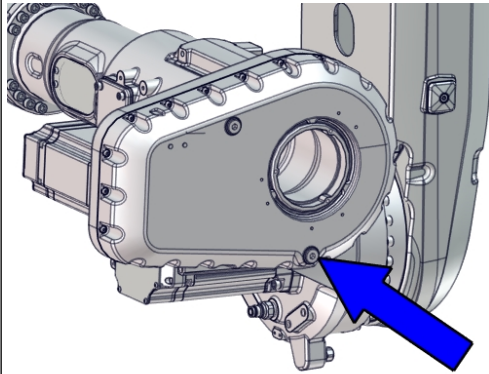
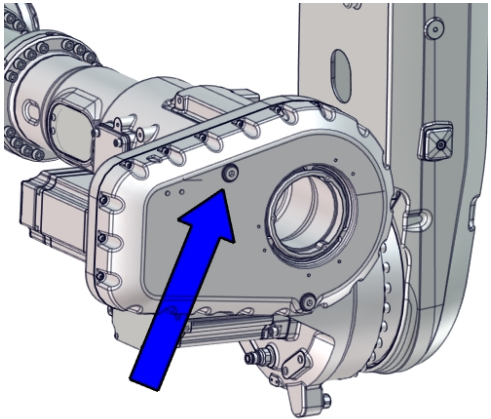
	
xx170000010	xx1600002048
Oil drain plug	Oil fill plug/level plug
Tightening torque: 24 Nm.	Tightening torque: 24 Nm.

Required tools and equipment

Equipment, etc.	Article number	Note
Oil collecting vessel	-	The capacity of the vessel must be sufficient to take the complete amount of oil.
Oil dispenser	-	One example of oil dispenser can be found in section <i>Type of lubrication in gearboxes</i> on page 147.
Standard toolkit	-	Content is defined in section <i>Standard toolkit</i> on page 724.

Required consumables and wear parts

Consumables	Article number	Note
Lubricating oil	-	Information about the oil is found in <i>Technical reference manual - Lubrication in gearboxes</i> .
O-ring, G 1/2"	3HAC061327-059	Used on oil plug. Always replace when refitting oil plug.

Required documents

Document name	Document number	Note
<i>Technical reference manual - Lubrication in gearboxes</i>	3HAC042927-001	

Continues on next page



3 Maintenance

3.4.5 Changing oil, axis-4 gearbox



Continued

Draining the axis-4 gearbox

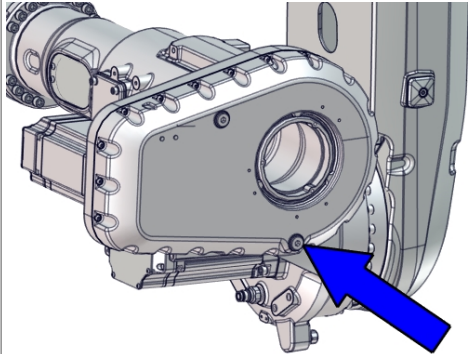
Use this procedure to drain the gearbox.

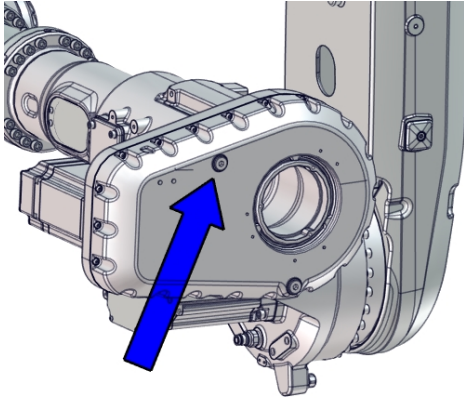

	Action	Note
1	Jog axis-3 to position -180°.	
2	 DANGER Turn off all: <ul style="list-style-type: none"> • electric power supply • hydraulic pressure supply • air pressure supply to the robot, before entering the safe-guarded space.	
3	 WARNING Handling gearbox oil involves several safety risks, see Gearbox lubricants (oil or grease) on page 33 .	
4	 CAUTION The gearbox can contain an <i>excess pressure</i> that can be hazardous. Open the oil plug carefully in order to let the excess pressure out.	
5	Place the oil collecting vessel underneath the oil drain plug.	
6	Remove the oil plug from the drain hole and let the oil run into the vessel.	 <p>xx170000010</p>

Continues on next page

	Action	Note
7	Remove the oil plug from the fill/level hole.  Note The level hole is opened to speed up the drainage.	 xx1600002048
8	 WARNING Used oil is hazardous material and must be disposed of in a safe way. See Decommissioning on page 711 for more information.	
9	Refill oil or refit the oil plugs with new o-rings.	O-ring, G 1/2": 3HAC061327-059 Tightening torque: 24 Nm.

Filling oil into the axis-4 gearbox

Use this procedure to refill the gearbox with oil.





	Action	Note
1	Jog axis-3 to position:-180°.	
2	 DANGER Turn off all: <ul style="list-style-type: none"> • electric power supply • hydraulic pressure supply • air pressure supply to the robot, before entering the safe-guarded space.	
3	 WARNING Handling gearbox oil involves several safety risks, see Gearbox lubricants (oil or grease) on page 33 .	

Continues on next page

3 Maintenance

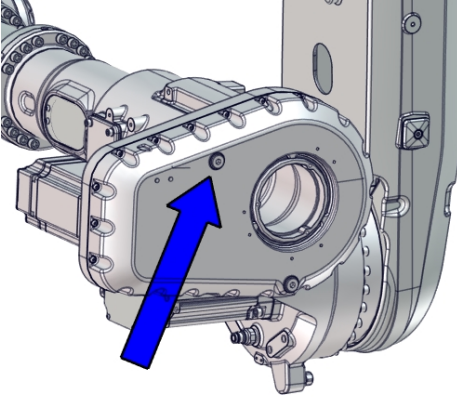
3.4.5 Changing oil, axis-4 gearbox

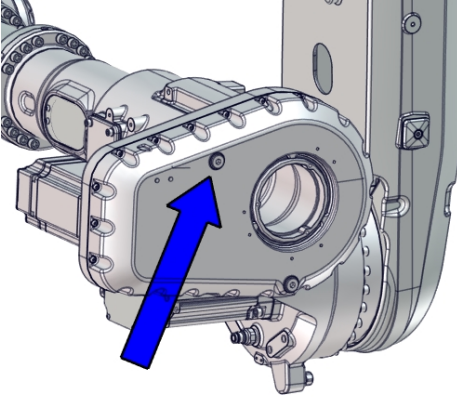
Continued

	Action	Note
4	Open the fill/level plug.	 <p>xx1600002048</p>
5	Refill the gearbox with oil.  Note The amount of oil to be filled depends on the amount previously being drained.	Type of oil and total amount is detailed in <i>Technical reference manual - Lubrication in gearboxes</i> .
6	Inspect the oil level.	The level is measured at the fill hole.  <p>xx1600002048</p> Required oil level is: 0 - 10 mm below the oil plug hole. See <i>Inspecting the oil level in axis-4 gearbox on page 117</i> .
7	Refit the oil plug with a new o-ring.	O-ring, G 1/2": 3HAC061327-059 Tightening torque: 24 Nm.
8	 DANGER Make sure all safety requirements are met when performing the first test run. See <i>Test run after installation, maintenance, or repair on page 97</i> .	

3.4.6 Changing oil, axis-5 gearbox

Location of oil plugs

The oil plugs of the gearbox are located as shown in the figure.

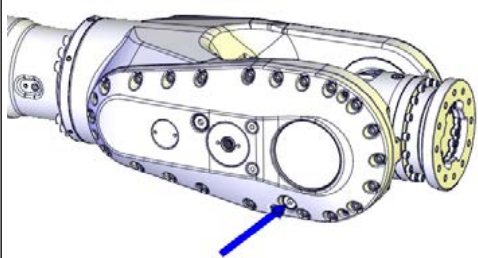
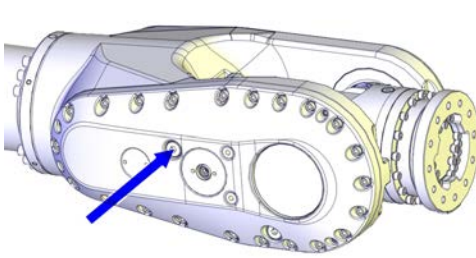
	
xx1200000958	xx1200000959
Oil drain plug	Oil fill plug/level plug
Tightening torque: 24 Nm.	Tightening torque: 24 Nm.

Required tools and equipment

Equipment, etc.	Article number	Note
Oil collecting vessel	-	The capacity of the vessel must be sufficient to take the complete amount of oil.
Oil dispenser	-	One example of oil dispenser can be found in section Type of lubrication in gearboxes on page 147 .
Standard toolkit	-	Content is defined in section Standard toolkit on page 724 .

Required consumables and wear parts

Consumables	Article number	Note
Lubricating oil	-	Information about the oil is found in <i>Technical reference manual - Lubrication in gearboxes</i> .
O-ring, G 1/2"	3HAC061327-059	Used on oil plug. Always replace when refitting oil plug.

Required documents

Document name	Document number	Note
<i>Technical reference manual - Lubrication in gearboxes</i>	3HAC042927-001	

Draining the axis-5 gearbox

Use this procedure to drain the gearbox.







	Action	Note
1	Jog axis-2 to 0°, and axis-4 to 180°.	

Continues on next page

3 Maintenance

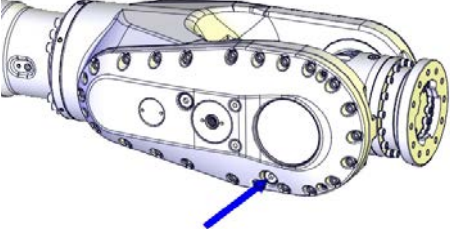
3.4.6 Changing oil, axis-5 gearbox

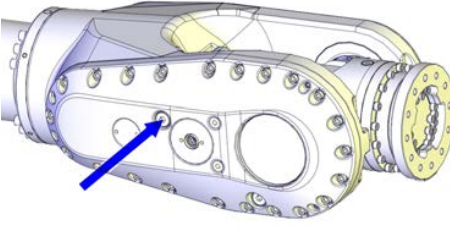
Continued





	Action	Note
2	<p> DANGER</p> <p>Turn off all:</p> <ul style="list-style-type: none"> • electric power supply • hydraulic pressure supply • air pressure supply <p>to the robot, before entering the safe-guarded space.</p>	
3	<p> WARNING</p> <p>Handling gearbox oil involves several safety risks, see Gearbox lubricants (oil or grease) on page 33.</p>	
4	<p> CAUTION</p> <p>The gearbox can contain an <i>excess pressure</i> that can be hazardous. Open the oil plug carefully in order to let the excess pressure out.</p>	
5	<p>Remove the oil plug from the drain hole and let the oil run into the vessel.</p>	 <p>xx1200000958</p>
6	<p>Place the oil collecting vessel underneath the oil drain plug.</p>	
7	<p> Note</p> <p>The fill hole is opened to speed up the drainage.</p>	 <p>xx1200000959</p>
8	<p> WARNING</p> <p>Used oil is hazardous material and must be disposed of in a safe way. See section Decommissioning on page 711 for more information.</p>	

Continues on next page

	Action	Note
9	Refill oil or refit the oil plug with a new o-ring.	O-ring, G 1/2": 3HAC061327-059 Tightening torque: 24 Nm.

Filling oil into the axis-5 gearbox

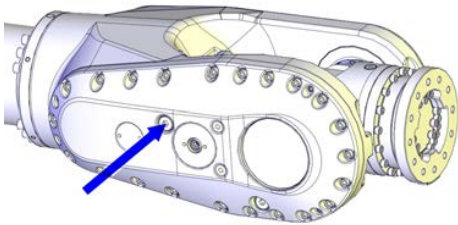
Use this procedure to refill the gearbox with oil.



	Action	Note
1	Jog axis-2 to 0°, and axis-4 to 180°.	
2	 DANGER Turn off all: <ul style="list-style-type: none"> • electric power supply • hydraulic pressure supply • air pressure supply to the robot, before entering the safe-guarded space.	
3	 WARNING Handling gearbox oil involves several safety risks, see Gearbox lubricants (oil or grease) on page 33 .	
4	Open the fill/level plug.	 <small>xx120000959</small>
5	Refill the gearbox with oil.  Note The amount of oil to be filled depends on the amount previously being drained.	Type of oil and total amount is detailed in <i>Technical reference manual - Lubrication in gearboxes</i> .

Continues on next page

3 Maintenance

3.4.6 Changing oil, axis-5 gearbox

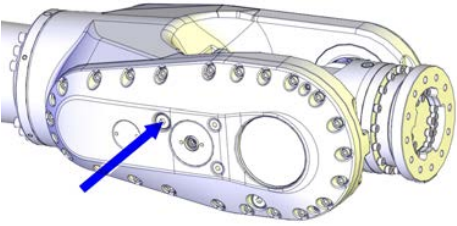
Continued

	Action	Note
6	Inspect the oil level at the oil fill/level hole (level plug).	 <p>xx1200000959</p> <p>Required oil level is: 0 - 10 mm below the oil plug hole.</p> <p>More information is found in Inspecting the oil level in axis-5 gearbox on page 120.</p>
7	Refit the oil plug with a new o-ring.	O-ring, G 1/2": 3HAC061327-059 Tightening torque: 24 Nm.
8	 DANGER Make sure all safety requirements are met when performing the first test run. See Test run after installation, maintenance, or repair on page 97 .	

3.4.7 Changing oil, axis-6 gearbox

Location of oil plugs

The oil plugs of the gearbox are located as shown in the figure.

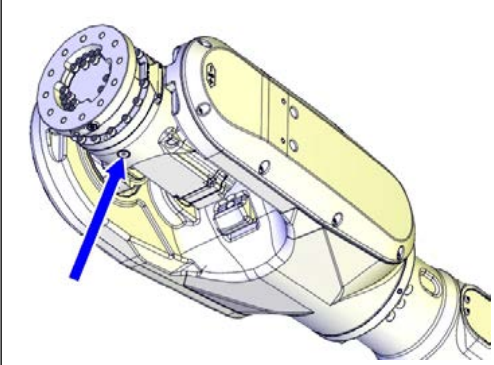
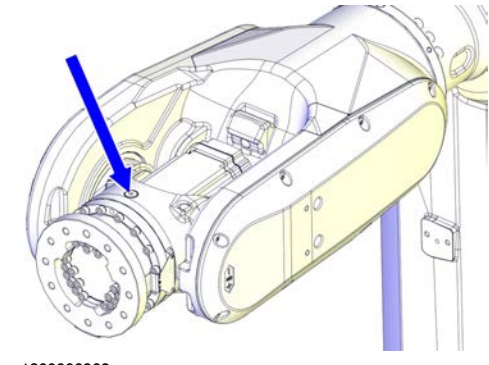
 <p>xx1200000962</p>	 <p>xx1200000963</p>
Oil drain plug	Oil fill plug
Tightening torque: 24 Nm.	Tightening torque: 24 Nm.

Required tools and equipment

Equipment, etc.	Article number	Note
Oil collecting vessel	-	The capacity of the vessel must be sufficient to take the complete amount of oil.
Oil dispenser	-	One example of oil dispenser can be found in section Type of lubrication in gearboxes on page 147 .
Standard toolkit	-	Content is defined in section Standard toolkit on page 724 .

Required consumables and wear parts

Consumables	Article number	Note
Lubricating oil	-	Information about the oil is found in <i>Technical reference manual - Lubrication in gearboxes</i> .
O-ring, G 1/4"	3HAC061327-060	Used on oil plug. Always replace when refitting oil plug.

Required documents

Document name	Document number	Note
<i>Technical reference manual - Lubrication in gearboxes</i>	3HAC042927-001	

Continues on next page





3 Maintenance

3.4.7 Changing oil, axis-6 gearbox

Continued

Draining the axis-6 gearbox

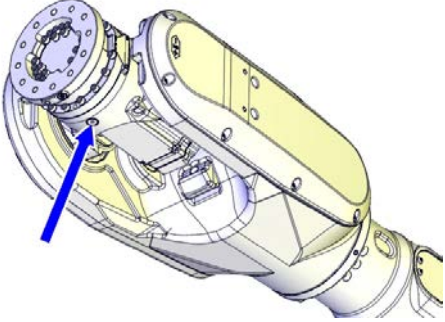
Use this procedure to drain the gearbox.

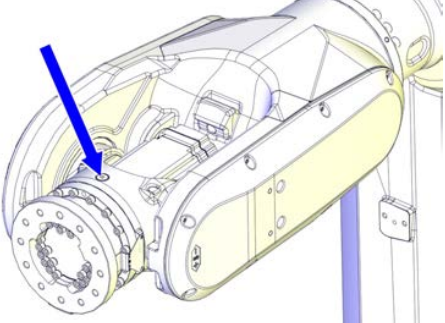



	Action	Note
1	Jog axis-4 to 180°.	
2	 DANGER Turn off all: <ul style="list-style-type: none"> • electric power supply • hydraulic pressure supply • air pressure supply to the robot, before entering the safe-guarded space.	
3	 WARNING Handling gearbox oil involves several safety risks, see Gearbox lubricants (oil or grease) on page 33 .	
4	 CAUTION The gearbox can contain an <i>excess pressure</i> that can be hazardous. Open the oil plug carefully in order to let the excess pressure out.	
5	Place the oil collecting vessel underneath the oil drain plug.	
6	Remove the oil plug from the drain hole and let the oil run into the vessel.	 <p style="text-align: right; font-size: small;">xx120000962</p>
7	Remove the oil plug from the fill hole.  Note The fill hole is opened to speed up the drainage.	 <p style="text-align: right; font-size: small;">xx120000963</p>

Continues on next page

	Action	Note
8	 WARNING Used oil is hazardous material and must be disposed of in a safe way. See section Decommissioning on page 711 for more information.	
9	Refill oil or refit the oil plugs with new o-rings.	O-ring, G 1/4": 3HAC061327-060 Tightening torque: 24 Nm.

Filling oil into the axis-6 gearbox

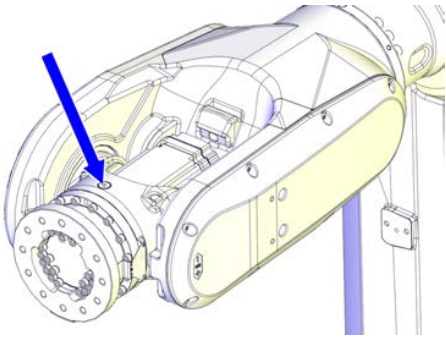
Use this procedure to refill the gearbox with oil.



	Action	Note
1	Jog axis 5 to horizontal position.	
2	 DANGER Turn off all: <ul style="list-style-type: none"> • electric power supply • hydraulic pressure supply • air pressure supply to the robot, before entering the safe-guarded space.	
3	 WARNING Handling gearbox oil involves several safety risks, see Gearbox lubricants (oil or grease) on page 33 .	
4	Open the fill plug.	 xx120000963
5	Refill the gearbox with oil.  Note The amount of oil to be filled depends on the amount previously being drained.	Type of oil and total amount is detailed in <i>Technical reference manual - Lubrication in gearboxes</i> .

Continues on next page

3 Maintenance

3.4.7 Changing oil, axis-6 gearbox

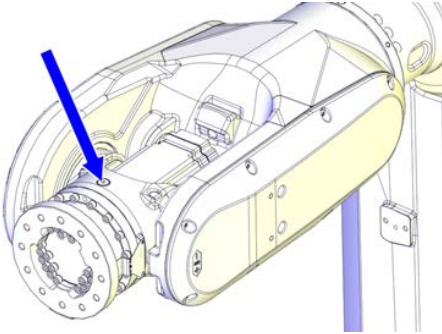
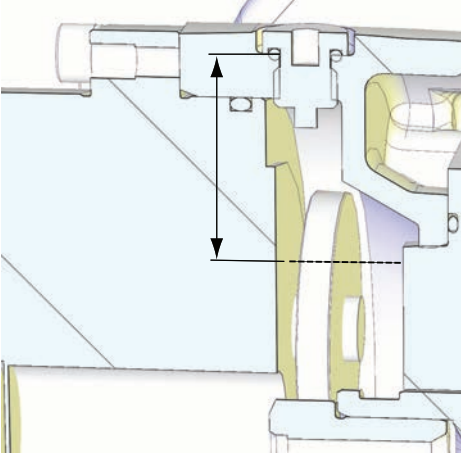
Continued

	Action	Note
6	<p>Check the oil level.</p> <p> Note</p> <p>The level is measured at the fill hole.</p>	<p>Method 1:</p>  <p>xx120000963</p> <p>Required oil level is: 45 mm ± 5 mm below the sealing surface of the oil plug.</p>  <p>xx130000693</p> <p>More information is found in Inspecting the oil level in axis-6 gearbox on page 123.</p> <p>Method 2:</p> <p>Rotate axis 5 +77°.</p> <p>Required oil level is: 0 - 10 mm below the oil plug hole.</p>
7	<p>Refit the oil plug with a new o-ring.</p>	<p>O-ring, G 1/4": 3HAC061327-060</p> <p>Tightening torque: 24 Nm.</p>
8	<p> DANGER</p> <p>Make sure all safety requirements are met when performing the first test run. See Test run after installation, maintenance, or repair on page 97.</p>	

3.4.8 Replacing the SMB battery



Note

The battery low alert (38213 Battery charge low) is displayed when the battery needs to be replaced. The recommendation to avoid an un-synchronized robot is to keep the power to the controller turned on until the battery is to be replaced.



WARNING

See [Hazards related to batteries on page 35](#).

Location of SMB battery

The SMB battery (SMB = serial measurement board) is located on the frame as shown in the figure below.

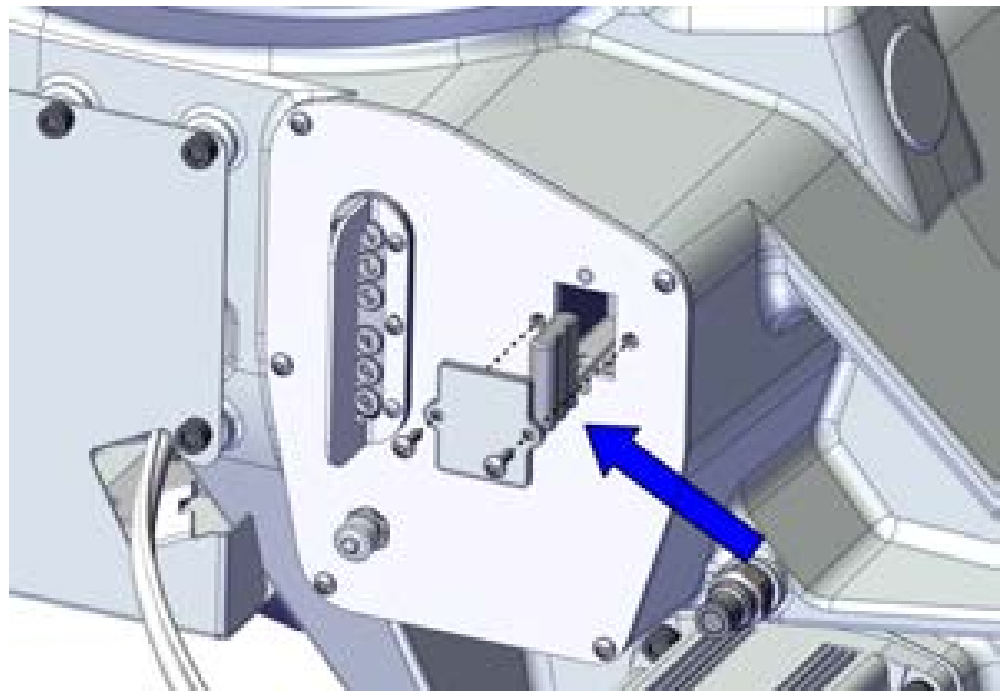

xx170000045

Required tools

Equipment	Article number	Note
Standard toolkit	-	Content is defined in section Standard toolkit on page 724 .

Continues on next page

3 Maintenance

3.4.8 Replacing the SMB battery



Continued

Required spare parts

Spare part	Article number	Note
Battery unit	See <i>Product manual, spare parts - IRB 6700/IRB 6700Inv</i>	Battery includes protection circuits. Only replace with the specified spare part or an ABB-approved equivalent.

Removing the battery



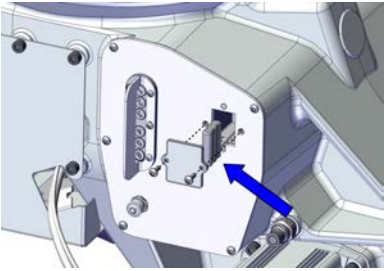

Use this procedure to remove the SMB battery.

	Action	Note
1	Jog the robot to its calibration position.	This is done in order to facilitate updating of the revolution counter.
2	 DANGER Turn off all: <ul style="list-style-type: none"> • electric power supply • hydraulic pressure supply • air pressure supply to the robot, before entering the safeguarded space.	
3	 ELECTROSTATIC DISCHARGE (ESD) The unit is sensitive to ESD. Before handling the unit read the safety information in section The unit is sensitive to ESD on page 54 .	
4	Remove the SMB battery cover by unscrewing the attachment screws.  CAUTION Clean cover from metal residues before opening. Metal residues can cause shortage on the boards which can result in hazardous failures.	 xx170000045
5	Pull out the battery and disconnect the battery cable.	
6	Remove the SMB battery. Battery includes protection circuits. Only replace with a specified spare part or with an ABB-approved equivalent.	

Continues on next page

Refitting the battery

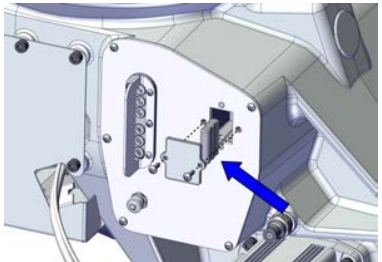
Use this procedure to refit the SMB battery.

	Action	Note
1	 DANGER Turn off all: <ul style="list-style-type: none"> • electric power supply • hydraulic pressure supply • air pressure supply to the robot, before entering the safeguarded space.	
2	 ELECTROSTATIC DISCHARGE (ESD) The unit is sensitive to ESD. Before handling the unit read the safety information in section The unit is sensitive to ESD on page 54 .	
3	Connect the battery cable and install the battery pack into the SMB/battery recess.	 xx1700000045
4	Secure the SMB battery cover with its attachment screws.	
5	Update the revolution counters.	See Updating revolution counters on IRC5 robots on page 690 .
6	 DANGER Make sure all safety requirements are met when performing the first test run. See Test run after installation, maintenance, or repair on page 97 .	

3 Maintenance

3.5.1 Lubricating the spherical roller bearing, balancing device

3.5 Lubrication activities

3.5.1 Lubricating the spherical roller bearing, balancing device

Location of spherical roller bearing

The spherical roller bearing is located in the link ear of the balancing device.

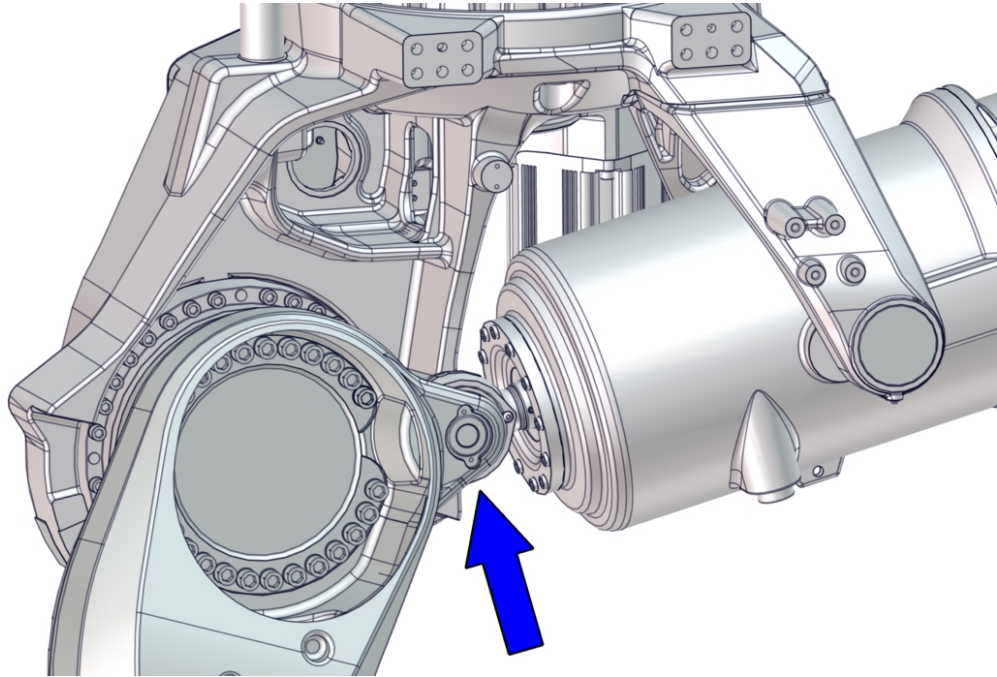

xx1700000318

Consumables

Equipment, etc.	Article number	Note
Bearing grease	3HAC042536-001	Shell Gadus S2 Used for lubrication of the spherical roller bearing.

Lubricating the spherical roller bearing

Use this procedure to lubricate the spherical roller bearing.

	Action	Note
1	 DANGER Turn off all: <ul style="list-style-type: none">• electric power supply• hydraulic pressure supply• air pressure supply to the robot, before entering the safe-guarded space.	

Continues on next page

3.5.1 Lubricating the spherical roller bearing, balancing device

Continued

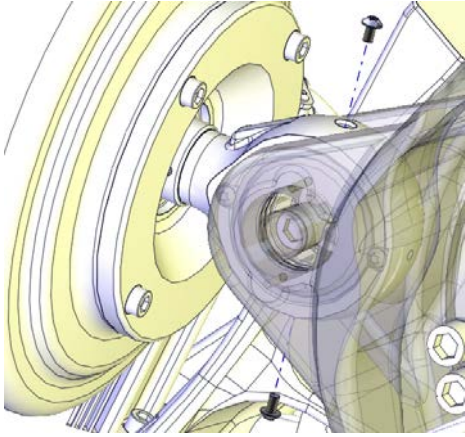
	Action	Note
2	<p> CAUTION</p> <p>Always cut the paint with a knife and grind the paint edge when disassembling parts. See <i>Cut the paint or surface on the robot before replacing parts on page 197.</i></p>	
3	<p>Unscrew both screws in link ear and fill the bearing with grease from the upper hole until the grease appears in the lower hole.</p>	<p>Bearing grease: 3HAC042536-001</p>  <p>xx1300000783</p>
4	<p>Refit the two screws and wipe clean from residual grease.</p>	

3 Maintenance

3.6.1 Cleaning the IRB 6700Inv / IRB 6700I

3.6 Cleaning activities

3.6.1 Cleaning the IRB 6700Inv / IRB 6700I



DANGER

Turn off all:

- electric power supply
- hydraulic pressure supply
- air pressure supply

to the robot, before entering the safeguarded space.

General

To secure high uptime it is important that the IRB 6700Inv / IRB 6700I is cleaned regularly. The frequency of cleaning depends on the environment in which the product works.

Different cleaning methods are allowed depending on the type of protection of the IRB 6700Inv / IRB 6700I.



Note

Always verify the protection type of the robot before cleaning.

Oil spills

Oil spills from gearboxes

Use the following procedure if any oil spills are detected that can be suspected to originate from a gearbox.

- 1 Inspect that the oil level in the suspected gearbox is according to the recommendations, see [Inspection activities on page 104](#).
- 2 Write down the oil level.
- 3 Inspect the oil level again after, for example, 6 months.
- 4 If the oil level is decreased then replace the gearbox.

Special cleaning considerations

This section specifies some special considerations when cleaning the robot.

- Always use cleaning equipment as specified. Any other cleaning equipment may shorten the life of the robot.
- Always check that all protective covers are fitted to the robot before cleaning.
- Never point the water jet at connectors, joints, sealings, or gaskets.
- Do not use compressed air to clean the robot.
- Never use solvents that are not approved by ABB to clean the robot.
- Do not spray from a distance closer than 0.4 m.

Continues on next page

- Do not remove any covers or other protective devices before cleaning the robot.

Cleaning methods

The following table defines what cleaning methods are allowed depending on the protection type.

Protection type	Cleaning method			
	Vacuum cleaner	Wipe with cloth	Rinse with water	High pressure water or steam
Standard	Yes	Yes. With light cleaning detergent.	Yes. It is highly recommended that the water contains a rust-prevention solution and that the manipulator is dried afterwards.	No
Foundry Plus	Yes	Yes. With light cleaning detergent or spirit.	Yes. It is highly recommended that the water contains a rust-prevention solution.	Yes ⁱ . It is highly recommended that the water and steam contains rust preventive, without cleaning detergents.

ⁱ Perform according to section [Cleaning with water and steam on page 185](#).

Cleaning with water and steam

Instructions for rinsing with water

ABB robots with protection types *Standard*, *Foundry Plus*, *Wash*, or *Foundry Prime* can be cleaned by rinsing with water (water cleaner).¹

The following list defines the prerequisites:

- Maximum water pressure at the nozzle: 700 kN/m² (7 bar)¹
- Fan jet nozzle should be used, min. 45° spread
- Minimum distance from nozzle to encapsulation: 0.4 meters
- Maximum flow: 20 liters/min¹

¹ Typical tap water pressure and flow

Instructions for steam or high pressure water cleaning

ABB robots with protection types *Foundry Plus*, *Wash*, or *Foundry Prime* can be cleaned using a steam cleaner or high pressure water cleaner.²

The following list defines the prerequisites:

- Maximum water pressure at the nozzle: 2500 kN/m² (25 bar)
- Fan jet nozzle should be used, min. 45° spread
- Minimum distance from nozzle to encapsulation: 0.4 meters
- Maximum water temperature: 80° C

¹ See [Cleaning methods on page 185](#) for exceptions.

² See [Cleaning methods on page 185](#) for exceptions.

Continues on next page

3 Maintenance

3.6.1 Cleaning the IRB 6700Inv / IRB 6700I

Continued

Cables

Movable cables need to be able to move freely:

- Remove waste material, such as sand, dust and chips, if it prevents cable movement.
- Clean the cables if they have a crusty surface, for example from dry release agents.

Cooling fans

Inspect the air supply inlet of the the motor cooling fans. Clean to remove any contamination that could hinder the air supply.

4 Repair

4.1 Introduction

Structure of this chapter

This chapter describes repair activities for the IRB 6700Inv / IRB 6700I. Each procedure contains the information required to perform the activity, for example spare parts numbers, required special tools, and materials.



WARNING

Repair activities not described in this chapter must only be carried out by ABB.

Report replaced units



Note

When replacing a part on the IRB 6700Inv / IRB 6700I, report to your local ABB the serial number, the article number, and the revision of both the replaced unit and the replacement unit.

This is particularly important for safety equipment to maintain the safety integrity of the installation.

Safety information

Make sure to read through the chapter [Safety on page 17](#) before commencing any service work.



Note

The robot should be secured with the transportation brackets during removing from/refitting to the foundation.



Note

If the IRB 6700Inv / IRB 6700I is connected to power, always make sure that the IRB 6700Inv / IRB 6700I is connected to protective earth and a residual current device (RCD) before starting any repair work.

For more information see:

- *Product manual - OmniCore V250XT*
- *Product manual - IRC5*
- *Product manual - IRC5 Panel Mounted Controller*

4 Repair

4.2.1 Performing a leak-down test

4.2 General procedures

4.2.1 Performing a leak-down test

When to perform a leak-down test

After refitting any motor and gearbox, the integrity of all seals enclosing the gearbox oil must be tested. This is done in a leak-down test.

The gearbox must be drained of oil before performing the leak-down test.

Required equipment

Equipment, etc.	Article number	Note
Leak-down tester	-	
Leak detection spray	-	

Performing a leak-down test

	Action	Note
1	Finish the refitting procedure of the motor or gear in question, but do not refill the gearbox with oil before performing the leak-down test.	
2	Remove the upper oil plug on the gear and replace it with the leak-down tester. Regulators, which are included in the leak-down test, may be required.	
3	Use caution, apply compressed air and raise the pressure with the knob until the correct value is shown on the manometer.  CAUTION The pressure must under no circumstance be higher than 0.25 bar (20-25 kPa). Also during the time when the pressure is raised.	Correct value: 0.2-0.25 bar (20-25 kPa)
4	Disconnect the compressed air supply.	
5	Wait for approximately 8-10 minutes and make sure that no pressure loss occurs.	If the compressed air is significantly colder or warmer than the gearbox to be tested, a slight pressure increase or decrease may occur. This is quite normal.
6	If any pressure drop occurred, then localize the leak as described in step 7. If no pressure drop occurred, then remove the leak-down tester and refit the oil plug. The test is complete.	
7	Spray any suspected leak areas with the leak detection spray. Bubbles indicate a leak.	
8	When the leak has been localized, take the necessary measures to correct the leak.	

4.2.2 Mounting instructions for bearings

General

This section describes how to mount and grease different types of bearings on the robot.

Equipment

Equipment, etc.	Article number	Note
Grease	3HAC042536-001	Shell Gadus S2 Used to grease the bearings, if not specified otherwise.

Assembly of all bearings

Attend to the following instructions while mounting a bearing on the robot.

	Action	Note
1	To avoid contamination, let a new bearing remain in its wrapping until it is time for fitting.	
2	Ensure that the parts included in the bearing fitting are free from burrs, grinding waste, and other contamination. Cast components must be free of foundry sand.	
3	Bearing rings, inner rings, and roller elements must not be subjected to direct impact. The roller elements must not be exposed to any stresses during the assembly work.	

Assembly of tapered bearings

Follow the preceding instructions for the assembly of the bearings when mounting a tapered bearing on the robot.

In addition to those instructions, the following procedure must be carried out to enable the roller elements to adjust to the correct position against the race flange.

	Action	Note
1	Tension the bearing gradually until the recommended pre-tension is achieved.  Note The roller elements must be rotated a specified number of turns before pre-tensioning is carried out and also rotated during the pre-tensioning sequence.	
2	Make sure the bearing is properly aligned as this will directly affect the durability of the bearing.	

Greasing of bearings



Note

This instruction is not valid for solid oil bearings.

Continues on next page

4 Repair

4.2.2 Mounting instructions for bearings

Continued

The bearings must be greased after assembly according to the following instructions:

- The bearings must not be completely filled with grease. However, if space is available beside the bearing fitting, the bearing may be totally filled with grease when mounted, as excessive grease will be pressed out from the bearing when the robot is started.
- During operation, the bearing should be filled to 70-80% of the available volume.
- Ensure that grease is handled and stored properly to avoid contamination.

Grease the different types of bearings as following description:

- *Grooved ball bearings* must be filled with grease from both sides.
- *Tapered roller bearings* and axial needle bearings must be greased in the split condition.

4.2.3 Mounting instructions for sealings

General

This section describes how to mount different types of sealings.

Equipment

Consumable	Article number	Note
Grease	3HAC042536-001	Shell Gadus S2

Rotating sealings

The following procedures describe how to fit rotating sealings.



CAUTION

Please observe the following before commencing any assembly of sealings:

- Protect the sealing during transport and mounting, especially the main lip on radial sealings.
- Keep the sealing in its original wrappings or protect it well before actual mounting.
- The fitting of sealings and gears must be carried out on clean workbenches.
- Use a protective sleeve for the main lip during mounting, when sliding over threads, keyways or other sharp edges.
- Do not lubricate a static side of a sealing with grease, since this may result in movement of the sealing during operation.

The only exception for lubrication of static sides of a sealing, is to use P-80 rubber lubrication gel against certain aluminium surfaces. If usage of P-80 is relevant, it is stated in the repair procedures.

Radial sealings

A radial sealing consists of a flexible rubber lip bonded to a rigid metal case. Only one side of the sealing is static with a metal insert.

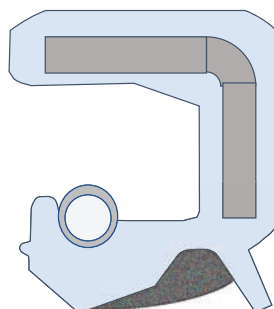



xx230000433

Continues on next page

4 Repair

4.2.3 Mounting instructions for sealings

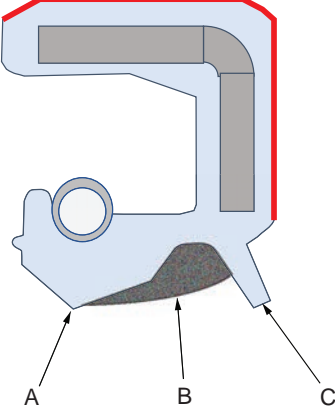
Continued

	Action	Note
1	Check the sealing to ensure that: <ul style="list-style-type: none"> • The sealing is of the correct type. • There is no damage on the main lip. 	
2	Inspect the shaft surface before mounting. If scratches or damage are found, the shaft must be replaced since it may result in future leakage. Do not try to grind or polish the shaft surface to get rid of the defect.	
3	Lubricate the sealing with grease just before fitting. (Not too early - there is a risk of dirt and foreign particles adhering to the sealing.) Fill 2/3 of the space between the dust lip and the main lip with grease. If the sealing is without dust lip, just lubricate the main lip with a thin layer of grease.	<p>Article number is specified in Equipment on page 191.</p>  <p>xx200000071</p> <p>A Main lip B Grease C Dust lip</p> <p> Note</p> <p>Ensure that no grease is applied to the red marked surface.</p>

Continues on next page

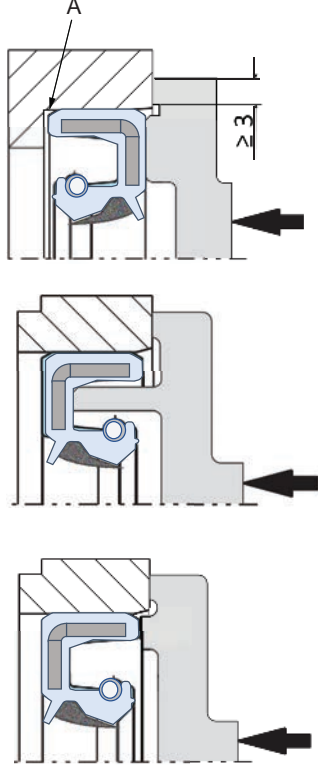
	Action	Note
4	Mount the sealing correctly with a mounting tool. Never hammer directly on the sealing as this may result in leakage.	 <p data-bbox="1091 1122 1203 1137">xx200000072</p> <p data-bbox="1129 1155 1214 1178">A Gap</p>

Flange sealings and static sealings

The following procedure describes how to fit flange sealings and static sealings.

	Action
1	Check the flange surfaces. They must be even and free from pores. It is easy to check flatness using a gauge on the fastened joint (without sealing compound). If the flange surfaces are defective, the parts may not be used because leakage could occur.
2	Clean the surfaces properly in accordance with the recommendations of ABB.
3	Distribute the sealing compound evenly over the surface.
4	Tighten the screws evenly when fastening the flange joint.

O-rings

The following procedure describes how to fit o-rings.

	Action	Note
1	Ensure that the correct o-ring size is used.	
2	Check the o-ring for surface defects, burrs, shape accuracy, or deformation.	Defective o-rings, including damaged or deformed o-rings, may not be used.

Continues on next page

4 Repair

4.2.3 Mounting instructions for sealings

Continued

	Action	Note
3	Check the o-ring grooves and mating surfaces. They should be free of pores, contamination and obvious scratches/damage.	
4	Lubricate the o-ring with grease.	
5	Tighten the screws evenly while assembling.	
6	Check that the o-ring is not squashed outside the o-ring groove.	

4.2.4 Service stops

Description

Some repair activities require the robot to be taken down to floor standing. The transportation lock screw must always be used when the robot is floor standing, but during some specific repair actions, the lock screw needs to be removed. In those cases, the movement of the lower arm is restricted with special service stops instead.

When to use the service stops is clearly stated in current repair procedures.

The service stops are stored at a parking position at the robot frame when not in use. Always return the service stops to their parking position after the repair activity is completed, according to the repair procedure.



WARNING

Never use the service stops as additional mechanical stops for restriction of the robot working range during operation.



DANGER

Only use the service stops when the information is given in the repair activities.

Continues on next page

4 Repair

4.2.4 Service stops

Continued

Location of the service stops

The service stops shown in the figure are located in their parking positions.

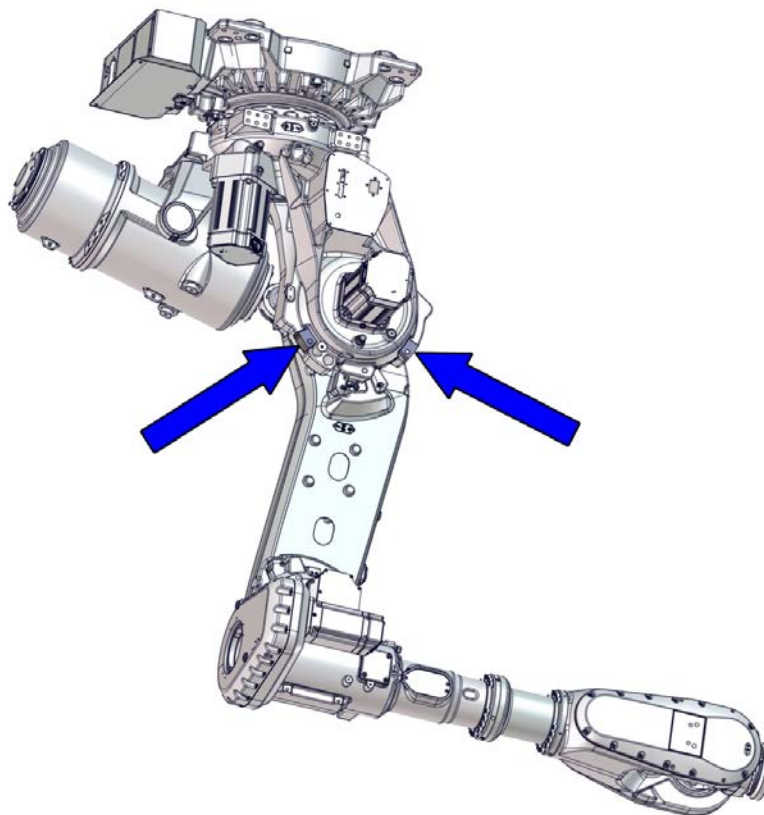

xx170000576

Required tools

Spare part	Article number	Note
Service stop	3HAC058167-001	Screws: 3HAB3409-88 Tightening torque: 70 Nm \pm 15 Nm.

4.2.5 Cut the paint or surface on the robot before replacing parts

4.2.5 Cut the paint or surface on the robot before replacing parts

General

Follow the procedures in this section whenever breaking the paint of the robot during replacement of parts.

Required equipment

Equipment	Spare parts	Note
Cleaning agent		Ethanol
Knife		
Lint free cloth		
Touch up paint Standard/Foundry Plus	3HAC067974-001	Graphite White

Removing

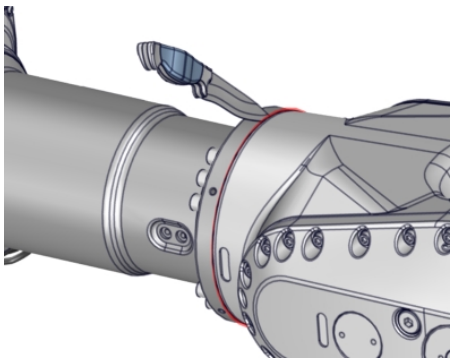
	Action	Description
1	Cut the paint with a knife in the joint between the part that will be removed and the structure, to avoid that the paint cracks.	 xx230000950
2	Carefully grind the paint edge that is left on the structure to a smooth surface.	

4 Repair

4.2.6 The brake release buttons may be jammed after service work

4.2.6 The brake release buttons may be jammed after service work

Description

The brake release unit has push-buttons for the brake release of each axis motor. When service work is performed inside the SMB recess that includes removal and refitting of the brake release unit, the brake release buttons may be jammed after refitting.



DANGER

If the power is turned on while a brake release button is jammed in depressed position, the affected motor brake is released. This may cause serious personal injuries and damage to the robot.

Elimination

To eliminate the danger after service work has been performed inside the SMB recess, follow the procedure below.

	Action
1	Make sure the power is turned off.
2	Remove the push-button guard, if necessary.
3	Verify that the push-buttons of the brake release unit are working by pressing them down, one by one. Make sure none of the buttons are jammed in the tube.
4	If a button gets jammed in the depressed position, the alignment of the brake release unit must be adjusted so that the buttons can move freely in their tubes.

4.3 Lifting associated procedures

4.3.1 Attaching lifting accessories to complete arm system

Definition of the complete arm system

The complete arm system consists of the following parts of the robot:

- upper arm
- wrist
- lower arm
- frame, including the balancing device.

Attachment points of lifting accessory

If using the Lifting accessory (chain)

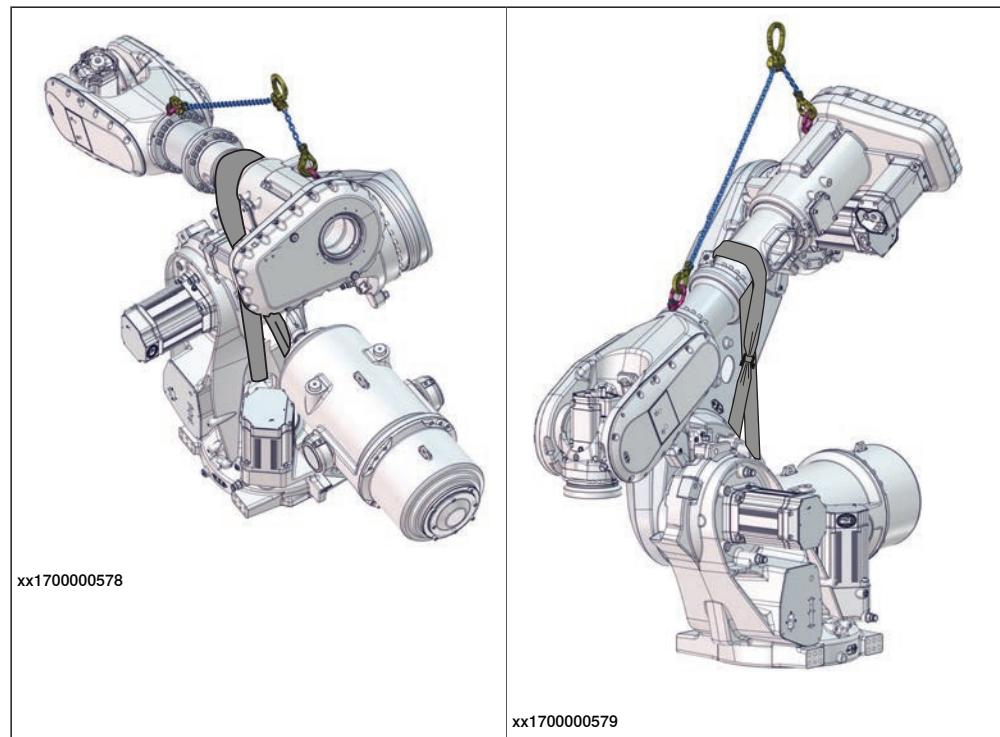

Continues on next page

4 Repair

4.3.1 Attaching lifting accessories to complete arm system

Continued

If using the Turning tool



xx170000695



Note

The robot must be taken down and secured floor standing in order for the lifting accessories to be installed.

How to do that is described in this section.



DANGER

Always lock the position of the lower arm, using the yellow sleeve and transportation lock screw, before attempting to lift the robot.

Continues on next page

4.3.1 Attaching lifting accessories to complete arm system

Continued

Required tools

Equipment, etc.	Article number	Note
Fork lift accessory set	3HAC058825-001	Contains fork lift pockets and all required hardware for installation. User instructions are enclosed with the tool, see Directions for use - Fork lift accessory 3HAC058825-001. In order to rotate the robot, either use the turning tool or a fork lift truck with a rotator attachment.
Turning tool	3HAC073537-001	Lift and rotation of inverted robot. Requires fork lift accessory set 3HAC058825-001. User instructions are enclosed with the tool.
Lifting eye, M12	3HAC16131-1	
Lifting eye, M12	3HAC16131-1	
Fender washer	-	Outer diameter: minimum 26 mm, maximum 30 mm, hole diameter: 13 mm, thickness: 3 mm.
Lifting shackle, 2 pcs	-	SA-10-8-NA1
Roundsling, 2 m	-	Lifting capacity: 2,000 kg.
Lifting accessory (chain)	3HAC15556-1	Lifting instruction 3HAC15880-2 enclosed.
Standard toolkit	-	Content is defined in section Standard toolkit on page 724 .

Attaching the lifting accessories

Preparations

	Action	Note
1	Take down and secure the robot floor standing in order to attach the lifting accessories for lift of the arm system.	See Lifting down the manipulator from inverted to floor-standing position on page 213 .

Attaching the lifting accessories to the arm system

This procedure contains two alternative methods for lifting the arm system, either by using the turning tool or by using lifting chains.



	Action	Note
1	 DANGER Make sure that all supplies for electrical power, hydraulic pressure, and air pressure are turned off.	

Continues on next page

4 Repair

4.3.1 Attaching lifting accessories to complete arm system

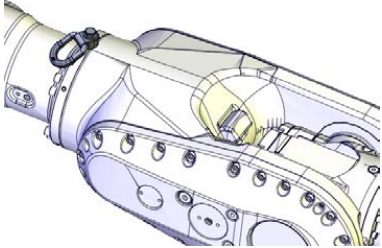
Continued

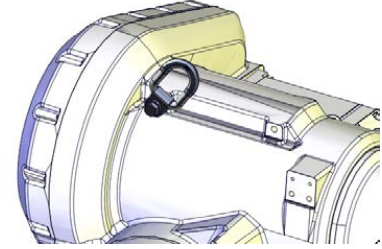
	Action	Note
2	<p> CAUTION</p> <p>The complete arm system weighs . 1,300 kg (IRB 6700Inv -300/2.60, -245/2.90) 1,320 kg (IRB 6700I -270/2.60 LID, -210/2.90 LID) All lifting accessories used must be sized accordingly!</p>	
3	<p>Fit a lifting eye to the wrist.</p>	<p>Lifting eye, M12: 3HAC16131-1</p>  <p>xx1200001133</p>
4	<p>Fit a lifting eye to the arm house, with a fender washer underneath.</p>  <p>xx1400002196</p>	<p>Lifting eye, M12: 3HAC16131-1 Fender washer. Outer diameter: minimum 26 mm, maximum 30 mm, hole diameter: 13 mm, thickness: 3 mm.</p>  <p>xx1200001134</p>
5	<p>Choose which lifting accessory to use:</p> <ul style="list-style-type: none"> • Attach the lifting chains on page 203 • Attach the Turning tool on page 205. Convenient if the tool is already partly mounted on the robot after rotation from inverted position to floor-standing. 	

Continues on next page

Attach the lifting chains

Use this procedure to attach the Lifting accessory (chain).

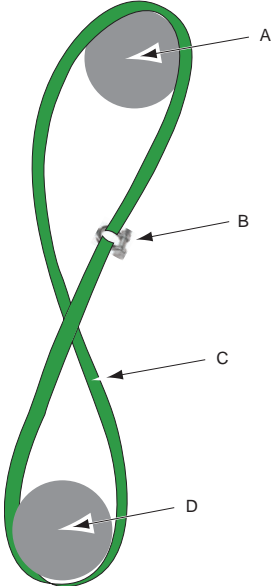
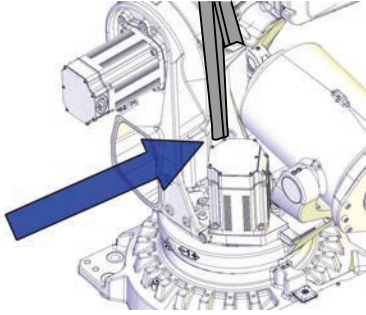
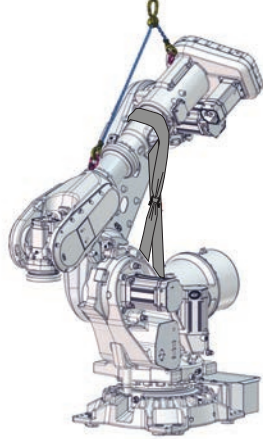

	Action	Note
1	<p>Run a roundsling through the hole in the frame, continue up and over the upper arm.</p> <p> Tip</p> <p>When attaching the roundsling, make sure to cross it over, creating a figure 8 of the roundsling. This will prevent the roundsling from gliding.</p>  <p>xx140000728</p> <p>A Upper arm B Shackle C Roundsling D Hole in frame</p>	<p>Roundsling, 2 m: Lifting capacity: 2,000 kg.</p>  <p>xx1400002107</p>  <p>xx1700000317</p>

Continues on next page

4 Repair

4.3.1 Attaching lifting accessories to complete arm system

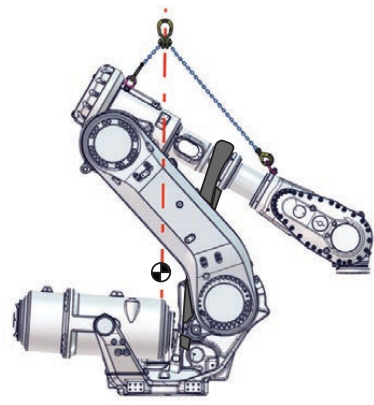

Continued

	Action	Note
2	Connect the roundsling with a shackle.	Lifting shackle, 2 pcs SA-10-8-NA1  <small>xx1400000729</small>
3	Use caution and jog axis-3 slowly to stretch the roundsling.  Note Make sure the roundsling is stretched, so it can carry the weight of the frame. The position of axis 3 will be approximately -45° .	
4	Attach the Lifting accessory (chain) to an overhead crane (or similar) and then to the lifting eye in the arm house and to the lifting eye in the wrist. Adjust the lengths of the chains so that the lifting hook is located in line with the center of gravity when the robot arm system is lifted, as shown in the figure.	Lifting accessory (chain): 3HAC15556-1  <small>xx1700000313</small>

Continues on next page

4.3.1 Attaching lifting accessories to complete arm system

Continued

	Action	Note
5	 <p>WARNING</p> <p>The angle between the two chains may not exceed 90°.</p>	 <p>xx1700000319</p>

Attach the Turning tool

Use this procedure to attach the Turning tool for lift of the arm system.

	Action	Note
1	<p>Secure the turning tool chain block to the lifting eye in the wrist. Shorten the chain to make the lift horizontal.</p>	<p>Turning tool: 3HAC073537-001</p>  <p>xx1700000695</p>
2	<p>Fit a roundsling between the overhead crane hook and the lifting eye in the arm house.</p>	

4 Repair

4.3.2 Attaching lifting accessories to an un-separated lower and upper arm

4.3.2 Attaching lifting accessories to an un-separated lower and upper arm

Attachment points of lifting accessory

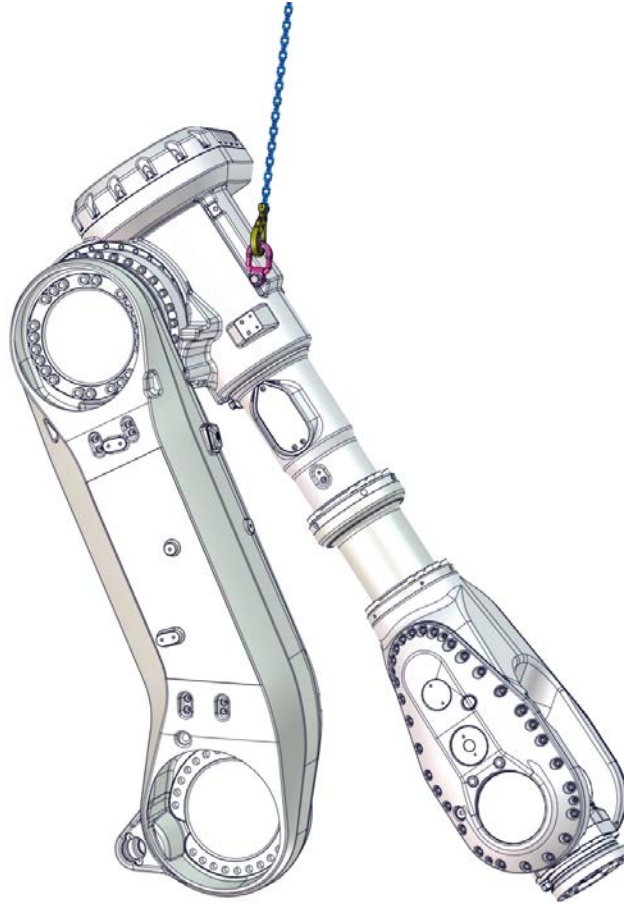

xx170000577



Note

The robot must be taken down and secured floor standing in order to perform this lift.

Required tools

Equipment, etc.	Article number	Note
Fork lift accessory set	3HAC058825-001	Contains fork lift pockets and all required hardware for installation. User instructions are enclosed with the tool, see Directions for use - Fork lift accessory 3HAC058825-001. In order to rotate the robot, either use the turning tool or a fork lift truck with a rotator attachment.

Continues on next page

4.3.2 Attaching lifting accessories to an un-separated lower and upper arm

Continued

Equipment, etc.	Article number	Note
Turning tool	3HAC073537-001	Lift and rotation of inverted robot. Requires fork lift accessory set 3HAC058825-001. User instructions are enclosed with the tool.
Lifting eye, M12	3HAC16131-1	
Lifting eye, M12	3HAC16131-1	
Fender washer	-	Outer diameter: minimum 26 mm, maximum 30 mm, hole diameter: 13 mm, thickness: 3 mm.
Lifting shackle, 2 pcs	-	SA-10-8-NA1
Roundsling, 2 m	-	Lifting capacity: 2,000 kg.
Lifting accessory (chain)	3HAC15556-1	Lifting instruction 3HAC15880-2 enclosed.
Standard toolkit	-	Content is defined in section Standard toolkit on page 724 .

Attaching lifting accessories to the lower and upper arm

Robot position

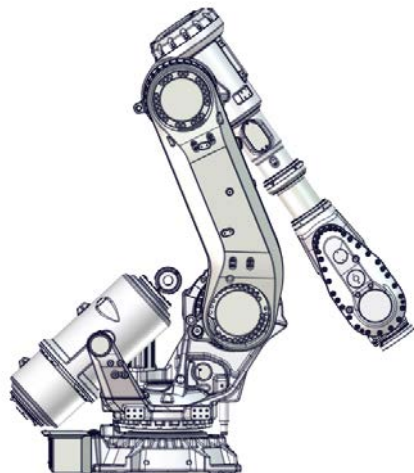
	Action	Note
1	Follow the procedure of replacing the axis-2 gearbox to get the robot prepared for attachment of the lifting accessories for lift of the un-separated lower and upper arm.	See Replacing the axis-2 gearbox on page 612 .
2	Jog the robot into position: <ul style="list-style-type: none"> Axis 1: position the axis 1 to be able to put down the arm system after removal Axis 2: -15° Axis 3: +70° (approximately) Axis 4: 0° Axis 5: 0° (-90° if DressPack is installed) Axis 6: 0° (+90° if DressPack is installed) 	 <p>xx170000374</p>

Continues on next page

4 Repair





4.3.2 Attaching lifting accessories to an un-separated lower and upper arm

Continued

	Action	Note
3	 DANGER Turn off all: <ul style="list-style-type: none"> • electric power supply • hydraulic pressure supply • air pressure supply to the robot, before entering the safe-guarded space.	

Attaching lifting accessories to the lower and upper arm

Use this procedure to attach the lifting accessories.

	Action	Note
1	 CAUTION The lower and upper arms together weigh (according to variants) 650 kg. All lifting accessories used must be sized accordingly.	
2	Fit a lifting eye with a fender washer in the arm house.  <small>xx1400002196</small>	Lifting eye, M12: 3HAC16131-1 Fender washer: Outer diameter: minimum 26 mm, maximum 30 mm, hole diameter: 13 mm, thickness: 3 mm.  <small>xx1700000376</small>
3	Attach the Lifting accessory (chain) to an overhead crane (or similar), then to the lifting eye in the arm house.	Lifting accessory (chain): 3HAC15556-1  <small>xx1700000377</small>

Continues on next page

4.3.2 Attaching lifting accessories to an un-separated lower and upper arm
Continued

	Action	Note
4	Raise the overhead crane to stretch the chain.	
5	To release the brake, connect the 24 VDC power supply. Connect to connector R2.MP2, axis-2 motor: <ul style="list-style-type: none">• + = pin 2• - = pin 5	

4 Repair

4.3.3 Attaching lifting accessories to the upper arm

4.3.3 Attaching lifting accessories to the upper arm

Attachment points of lifting accessory

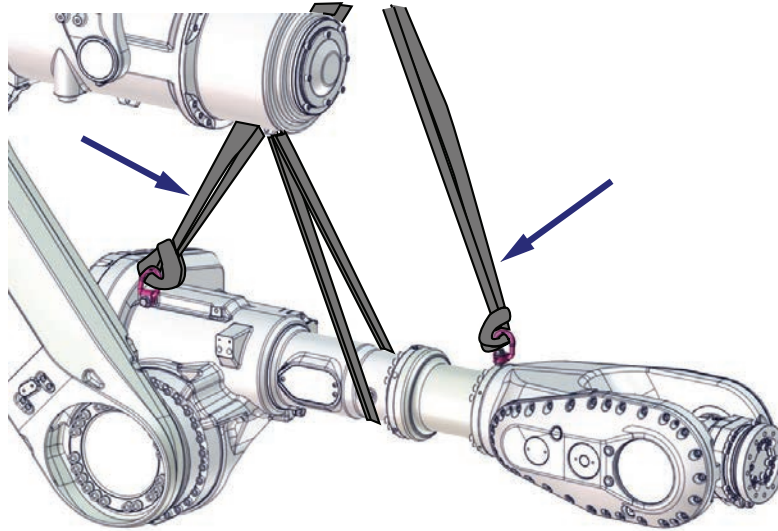

xx170000693

Required equipment

Equipment, etc.	Article number	Note
Lifting eye, M12	3HAC16131-1	
Lifting eye, M12	3HAC16131-1	
Fender washer	-	Outer diameter: minimum 26 mm, maximum 30 mm, hole diameter: 13 mm, thickness: 3 mm.
Roundsling, 2 m	-	Lifting capacity: 2,000 kg.
Roundsling, 2 m	-	Lifting capacity: 2,000 kg.
Standard toolkit	-	Content is defined in section Standard toolkit on page 724 .

Robot position





	Action	Note
1	<p>Jog the robot to the position:</p> <ul style="list-style-type: none"> Axis-1: a position that allows best possible access to fit the lifting accessories to the upper arm. Axis-2: -35 Axis-3: -143 (so that the upper arm is horizontal) Axis-4: 0° Axis-5: -90° Axis-6: 0° 	<p>xx170000450</p>

Continues on next page

Attaching lifting accessories

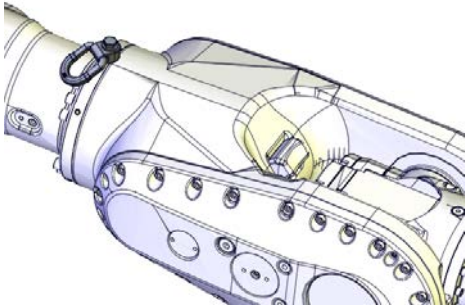
Attaching the lifting accessories to the upper arm

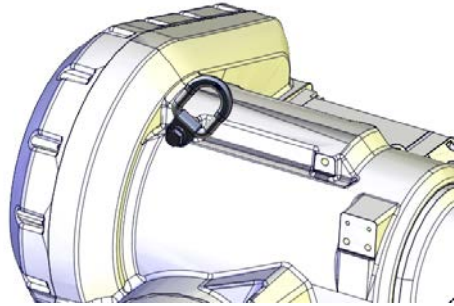
Use this procedure to attach the lifting accessories to the upper arm.

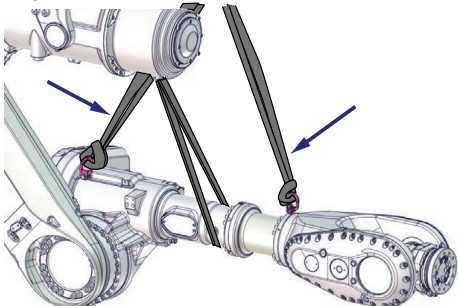
	Action	Note
1	 CAUTION The weight of the complete upper arm (including the wrist) is 465 kg All lifting accessories used must be sized accordingly.	
2	Fit a lifting eye to the wrist.	Lifting eye, M12: 3HAC16131-1  xx1200001133
3	Fit a lifting eye in the arm house, with a fender washer underneath.  xx1400002196	Lifting eye, M12: 3HAC16131-1 Fender washer: Outer diameter: minimum 26 mm, maximum 30 mm, hole diameter: 13 mm, thickness: 3 mm.  xx1200001134
4	Attach a lifting sling to an overhead crane (or similar) and then to the lifting eye in the arm house.	Roundsling, 2 m: Lifting capacity: 2,000 kg. (2 pcs) 
5	Attach a lifting sling to an overhead crane (or similar) and then to the lifting eye in the wrist.  Note Lifting slings are used instead of lifting chains to not damage the balancing device surface.	 xx1700000693

Continues on next page

4 Repair

4.3.3 Attaching lifting accessories to the upper arm

Continued

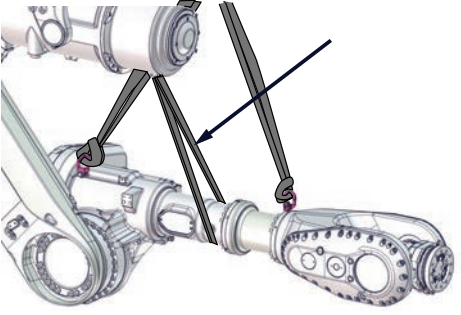
	Action	Note
6	Raise the lifting accessories to take the weight of the upper arm.	
7	Remove the lifting sling between the upper arm and the balancing device.	 <p>xx180000047</p>

4.3.4 Lifting down the manipulator from inverted to floor-standing position

General

This section details how to lift down the robot from its inverted position, rotate it and secure it floor mounted in order to perform service procedures that require the robot to be standing on the floor.



DANGER

Always lock the position of the lower arm, using the yellow sleeve and transportation lock screw, before attempting to lift the robot.



DANGER

Always keep the the transportation lock screw and sleeve in locked position when the robot is floor standing. During some repair activities, the transportation lock screw and sleeve is replaced with service stops. These situations are clearly stated in the current repair activities in this manual.

Required tools and equipment

Equipment	Article number	Note
Fork lift accessory set	3HAC058825-001	Contains fork lift pockets and all required hardware for installation. User instructions are enclosed with the tool, see Directions for use - Fork lift accessory 3HAC058825-001. In order to rotate the robot, either use the turning tool or a fork lift truck with a rotator attachment.
Turning tool	3HAC073537-001	Lift and rotation of inverted robot. Requires fork lift accessory set 3HAC058825-001. User instructions are enclosed with the tool.

Required documents

Document	Document number
Directions for use - Fork lift accessory 3HAC058825-001	3HAC060303-001
Directions for use - Lifting and rotating accessory for IRB 6700Inv/IRB6700I	3HAC073537-003

Continues on next page

4 Repair

4.3.4 Lifting down the manipulator from inverted to floor-standing position



Continued

Removing the robot from inverted position

Use these procedures to lift down the robot from inverted position and rotate it to floor standing.

Securing the lower arm

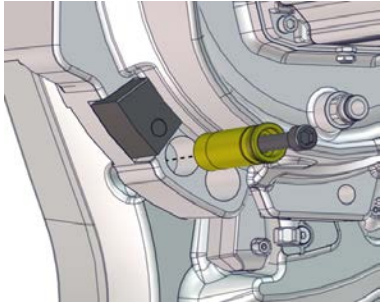
Use this procedure to secure the lower arm.

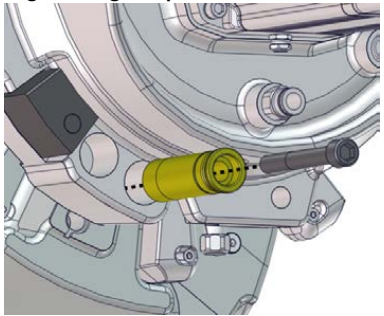
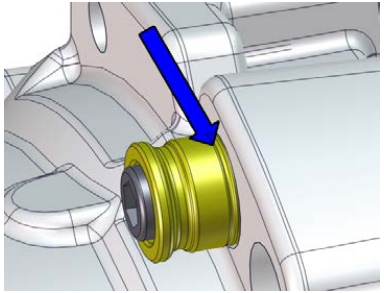
	Action	Note
1	Jog axis 2 to -35° .	
2	Remove the transportation lock screw and the yellow sleeve from the parking position.	 xx1700000270
3	Insert the yellow sleeve and the transportation lock screw in the hole at the locking position. Insert the sleeve all the way so that the marking in the sleeve is aligned with the casting, see figure. Tighten the screw.  DANGER Always use the transportation lock screw and sleeve to lock the lower arm at transportation, turning and floor standing.	Tightening torque: $70 \text{ Nm} \pm 15 \text{ Nm}$.  xx1700000269  xx1600002114





Lifting down the robot from inverted position

	Action	Note
1	 DANGER The robot must always be secured to the foundation if any kind of repair or maintenance work is to be performed. For some repair work support legs are required.	Suitable screws, lightly lubricated: M24x100 (min. 4 pcs) For hole configuration, see Hole configuration, base on page 66 .

Continues on next page

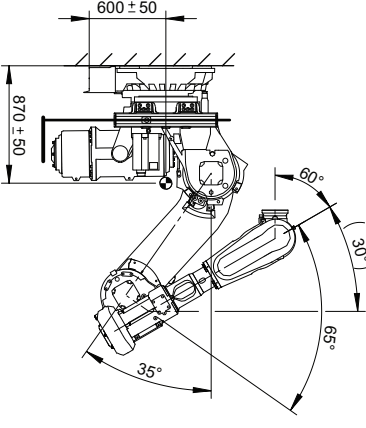
4.3.4 Lifting down the manipulator from inverted to floor-standing position

Continued



	Action	Note
2	Verify that the lower arm is secured with the transportation lock screw.	
3	Remove any payload and tools from the robot.	DressPack can stay fitted.
4	Jog the robot into position: <ul style="list-style-type: none"> • Axis 1: 0° • Axis 2: already in position and locked with the transportation lock screw, do not jog! • Axis 3: +65° • Axis 4: 0° • Axis 5: +60° • Axis 6: no significance 	 <p>xx1700000555</p>
5	 DANGER Turn off all: <ul style="list-style-type: none"> • electric power supply • hydraulic pressure supply • air pressure supply to the robot, before entering the safeguarded space.	
6	Disconnect the robot cables at the base.	
7	 CAUTION The weight of the IRB 6700Inv / IRB 6700I robot is 1,750 kg All lifting accessories used must be sized accordingly.	
8	Install the fork lift pockets to the robot.  DANGER Handling the tool incorrectly will cause serious injury. Read and follow enclosed user instructions for the tool.	See user instructions enclosed with the fork lift accessory set. Fork lift accessory set: 3HAC058825-001.

Continues on next page

4 Repair

4.3.4 Lifting down the manipulator from inverted to floor-standing position

Continued

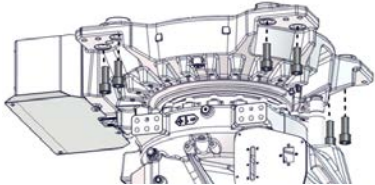
	Action	Note
9	<p>Choose one of the following lifting methods:</p> <ul style="list-style-type: none"> Lifting and turning with the fork lift (rotator attachment required): <ol style="list-style-type: none"> 1 Insert the forks of the fork lift truck into the fork lift pockets, as far as possible. 2 Raise the forks of the fork lift truck to make sure that the weight of the robot rests on the forks. <p> Tip</p> <p>Two M16 screws can be fitted to the fork lift pockets, to press the forks against the pockets and make the lift more stable.</p> Lifting and turning with the turning tool and overhead crane: <ol style="list-style-type: none"> 1 Install and use the turning tool according to enclosed user instructions. <p> DANGER</p> <p>Handling the tool incorrectly will cause serious injury. Read and follow enclosed user instructions for the tool.</p> 	
10	<p>Remove the bolts that secure the robot to the foundation.</p>	<p>Quantity: 8 pcs.</p>  <p>xx1600002098</p>
11	<p>Rotate the robot to floor standing position.</p>	<p>Follow the user instructions enclosed with the turning tool.</p>
12	<p>Lower and secure the robot to the floor. (Or to support legs, if replacing the axis-1 gear-box.) The lifting accessories can be kept installed if they are not in the way for the upcoming service procedure.</p>	<p>Attachment screws: M24x100 (min. 4 pcs required to perform service)</p>

4.4 Complete robot

4.4.1 Removing the cable harness

Location of the cable harness

The cable harness is located as shown in the figure.

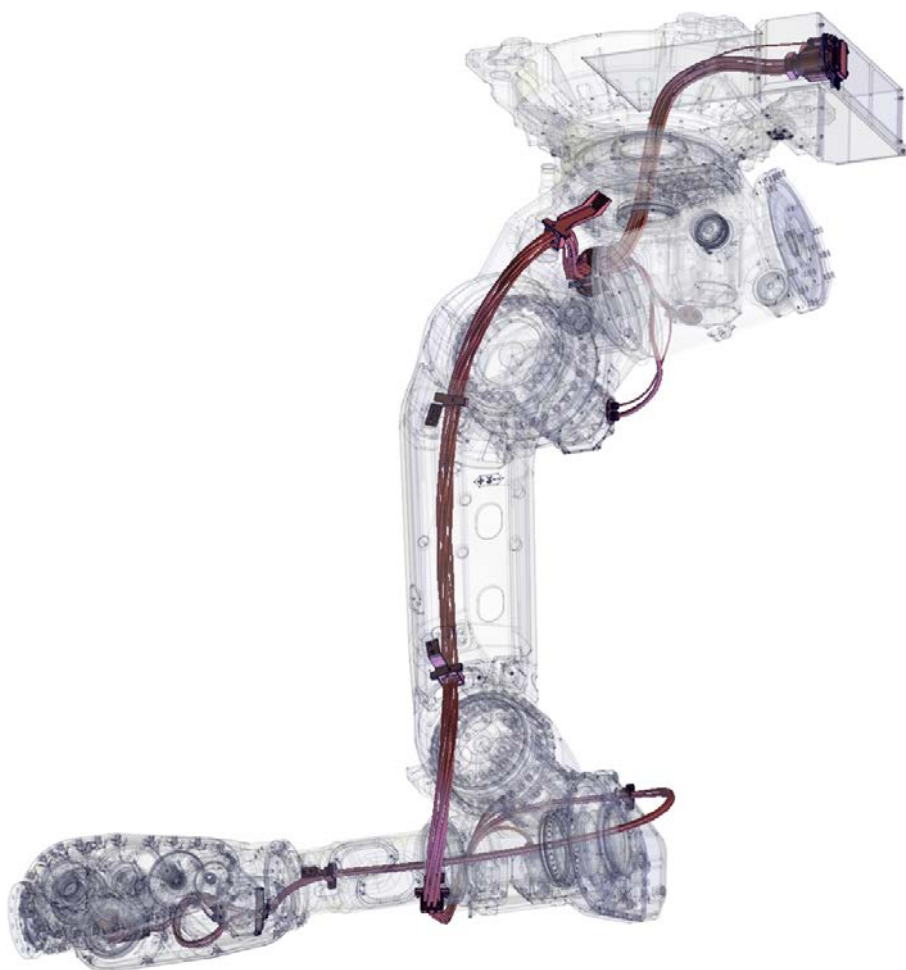

xx1600002063

Required tools and equipment

Equipment, etc.	Article number	Note
Standard toolkit	-	Content is defined in section Standard toolkit on page 724 .

Continues on next page

4 Repair

4.4.1 Removing the cable harness



Continued

Preparations before removing the cable harness



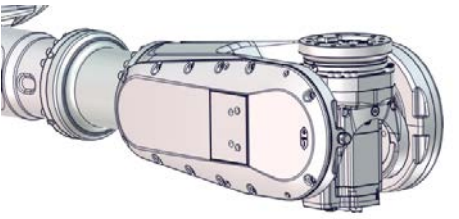
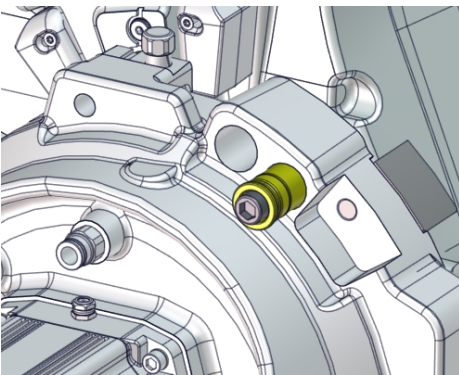

Note

Handle the cables carefully to avoid any scratches or damage that lead to leakage when the system is pressurized.

	Action	Note
1	<p>Jog the robot to the specified position:</p> <ul style="list-style-type: none"> • Axis 1: 0° • Axis 2: -35° • Axis 3: +35° • Axis 4: 0° • Axis 5: +90° • Axis 6: No significance. <p> Note</p> <p>The specified position is a recommended position for an inverted robot. If the robot has been taken down to floor standing, the robot arm positions given are inaccurate for replacement of the cable harness.</p> <p>Axis-5 must be oriented as close as possible to +90° to be able to open the axis-6 motor cover and to remove the axis-6 motor cables, and in order to avoid the spiral of the cable harness in the carrier, being unwound or placed in the wrong position.</p> <p>Depending on what tool is used, the other axes may need to be jogged to another position.</p> <p> Note</p> <p>Handle the cables carefully to avoid any scratches or damage that lead to leakage when the system is pressurized.</p>	 <p>xx1600002054</p>
2	<p>Remove the transportation lock screw and the yellow sleeve from the parking position.</p>	 <p>xx1700000348</p>

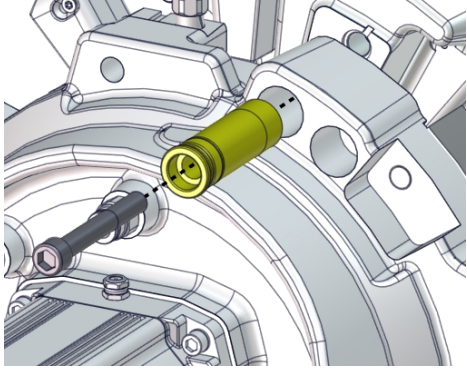
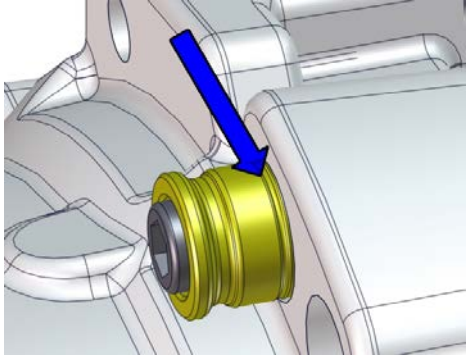
Continues on next page

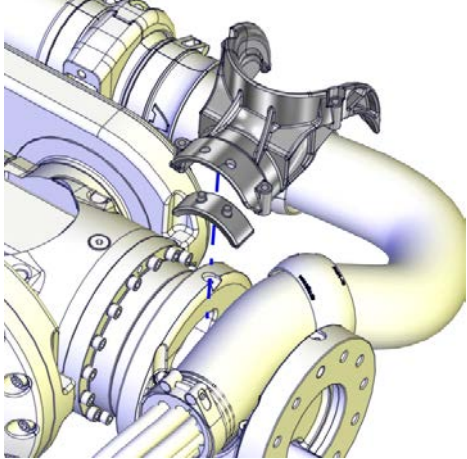
	Action	Note
3	<p>Insert the yellow sleeve and the transportation lock screw in the hole at the locking position.</p> <p>Insert the sleeve all the way so that the marking in the sleeve is aligned with the casting, see figure.</p> <p>Tighten the screw.</p> <p> DANGER</p> <p>Always use the transportation lock screw and sleeve to lock the lower arm at transportation, turning and floor standing.</p>	<p>Tightening torque: 70 Nm \pm15 Nm</p>  <p>xx1700000347</p>  <p>xx1600002114</p>
4	<p> DANGER</p> <p>Turn off all:</p> <ul style="list-style-type: none"> • electric power supply • hydraulic pressure supply • air pressure supply <p>to the robot, before entering the safeguarded space.</p>	
5	<p> Note</p> <p>If only the manipulator harness shall be removed, the DressPack cable package can stay fitted on the process turning disk.</p>	 <p>xx1400000208</p>

Continues on next page

4 Repair

4.4.1 Removing the cable harness

Continued

Removing the cable harness - upper arm and wrist



These procedures describe how to remove the cable harness in the upper arm and wrist.

Retrieving access to the wrist cabling

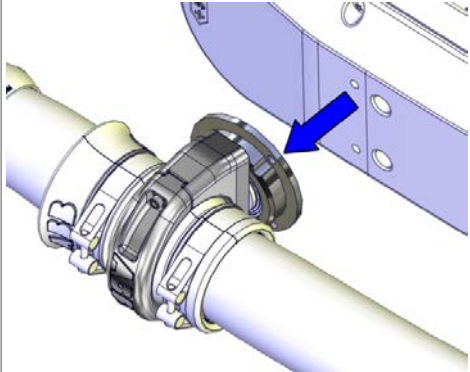
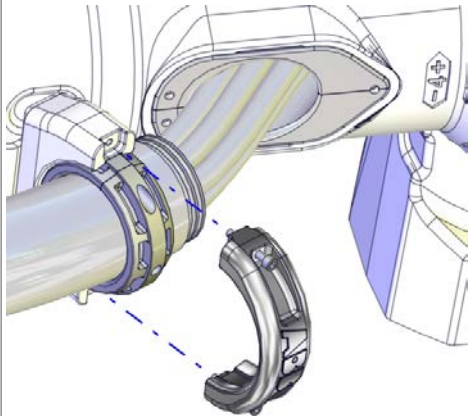
Use this procedure to remove the wrist cover to retrieve access to the axis-5 and axis-6 motor cables.

	Action	Note
1	 DANGER Make sure that all supplies for electrical power, hydraulic pressure, and air pressure are turned off.	
2	If DressPack is installed: <ul style="list-style-type: none">Remove the bracket with the complete ball joint housing still fitted, as shown in the figure. This is done to be able to reach the two hidden screws that secure the wrist cover.	 xx1400000355
3	If used, open the ball joint housing on the arm tube and remove the DressPack cable package.	 xx1400000206

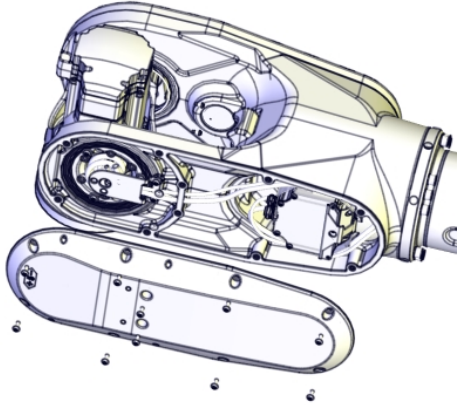
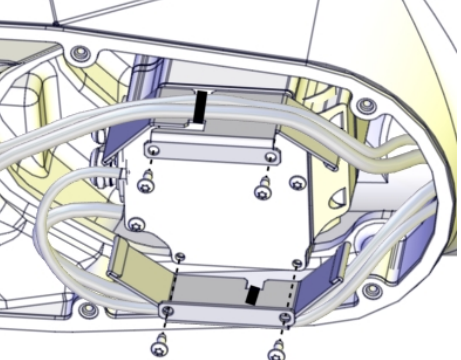
Continues on next page

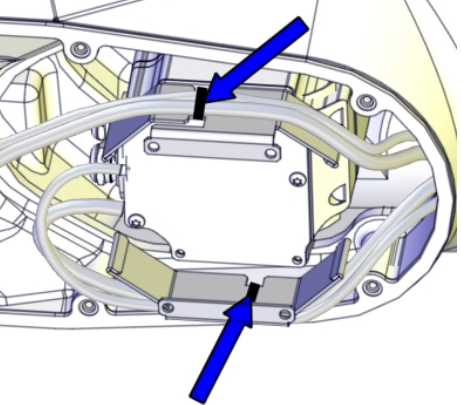
	Action	Note
4	Remove the wrist cover.	 <p data-bbox="979 741 1082 763">xx1300002247</p>
5	Remove the heat protection plates from the motor with the cabling still attached to the plate.	 <p data-bbox="979 1218 1082 1240">xx1500001030</p>
6	<p data-bbox="497 1279 954 1330">Cut the cable ties that hold the cable harness to the plate.</p> <p data-bbox="497 1346 960 1451">  Note Keep the heat protection plate until refitting. </p> <p data-bbox="497 1467 960 1637">  Tip If removing the plate only for replacing the motor, the cabling does not need to be loosened from the plate. </p>	 <p data-bbox="979 1697 1082 1720">xx1500001029</p>

Continues on next page

4 Repair

4.4.1 Removing the cable harness

Continued

Disconnecting the axis-6 motor cables

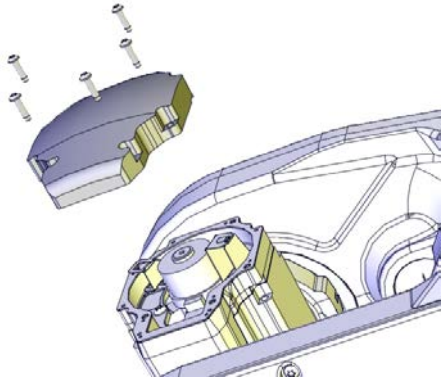
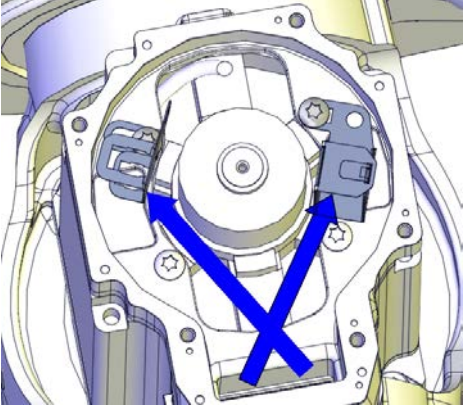
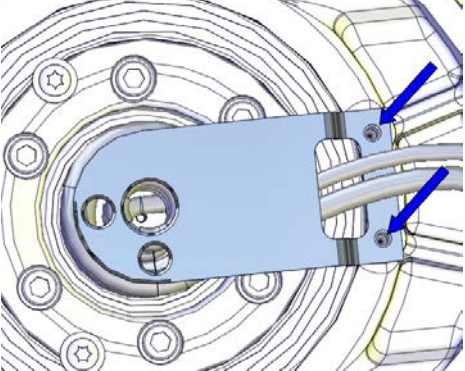
	Action	Note
1	 DANGER Make sure that all supplies for electrical power, hydraulic pressure, and air pressure are turned off.	
2	Unscrew the attachment screws and remove the motor cover.	 xx1200001080
3	Disconnect the motor cables.	 xx1300000488
4	Unscrew the attachment screws that hold the cable bracket.	 xx1300000484

Continues on next page

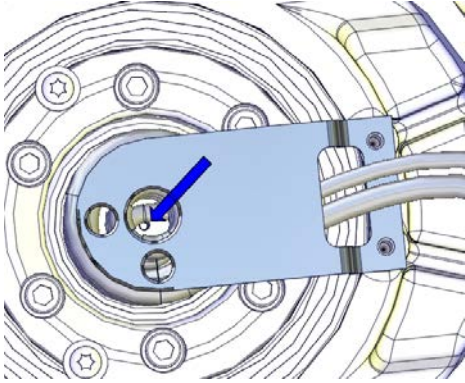
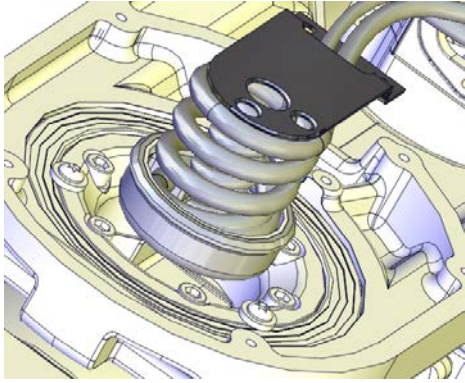
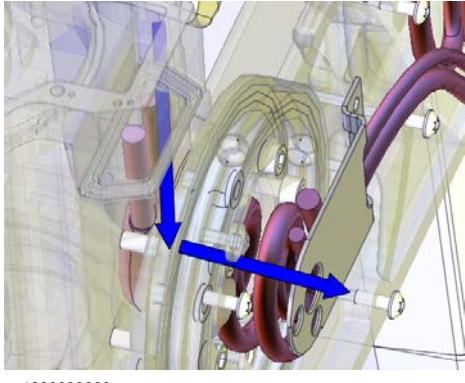
	Action	Note
5	<p>Unscrew the M4 screw that holds the carrier.</p> <p> Note</p> <p>The screw is located at the bottom of the carrier.</p>	 <p>xx130000485</p>
6	<p>Pull out the carrier from its position.</p>	 <p>xx1300001113</p>
7	<p>Pull out the axis-6 motor cables by holding the cables with one hand at the motor and the other at the carrier.</p>	 <p>xx130000666</p>

Disconnecting the axis-5 motor cables

	Action	Note
1	<p> DANGER</p> <p>Make sure that all supplies for electrical power, hydraulic pressure, and air pressure are turned off.</p>	

Continues on next page

4 Repair

4.4.1 Removing the cable harness

Continued

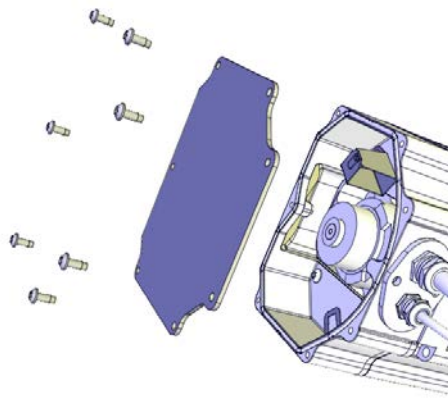
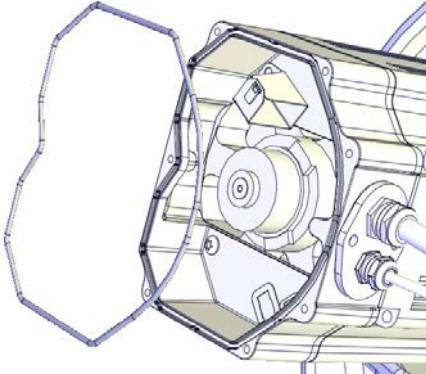
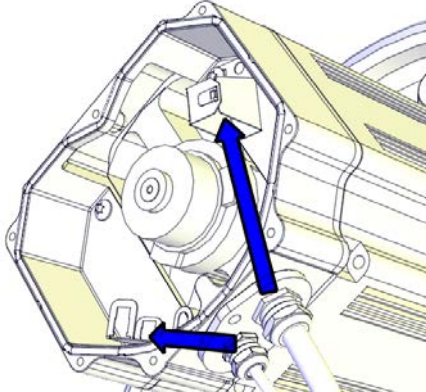
	Action	Note
2	Unscrew the attachment screws and washers and remove the motor cover.	 xx1200001135
3	Make sure the o-ring is present.	 xx1200001070
4	Disconnect the motor cables.	 xx1200001066

Continues on next page

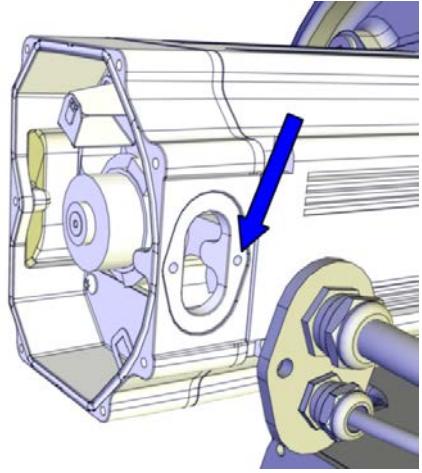
	Action	Note
5	<p>Remove the cable gland cover by performing the following steps:</p> <ol style="list-style-type: none"> 1 Open the inner screw a little (the one the arrow is pointing at). No need to remove this screw from the motor. 2 Remove the outer screw. 3 Slide the cable gland cover away from the inner screw. Make sure the gasket is not damaged. <p> Tip</p> <p>Make a note in which direction the cable exit hole is facing, if the motor will be removed too. The motor shall be refitted in the same position.</p>	 <p>xx1300000656</p>
6	Use caution and pull out the motor cables.	

Disconnecting the axis-3 and axis-4 motor cables

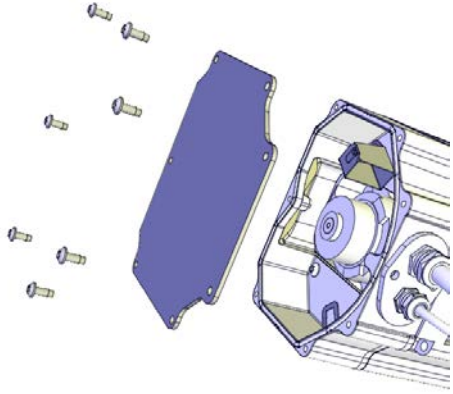

	Action	Note
1	<p> DANGER</p> <p>Make sure that all supplies for electrical power, hydraulic pressure, and air pressure are turned off.</p>	
2	Unscrew the attachment screws and washers and remove the motor cover.	 <p>xx1200001135</p>

Continues on next page

4 Repair

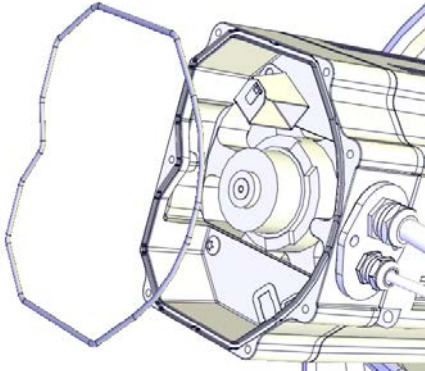
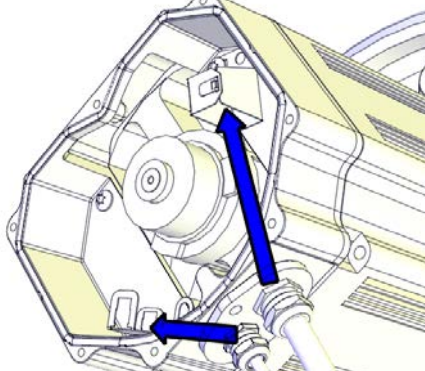

4.4.1 Removing the cable harness

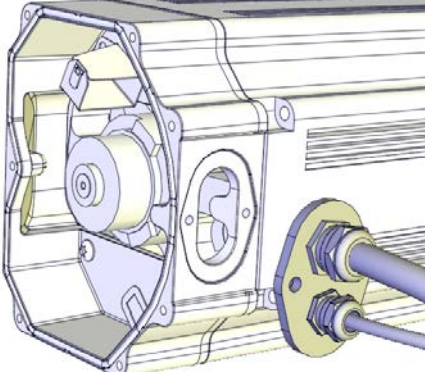
Continued

	Action	Note
3	Make sure the o-ring is present.	 xx1200001070
4	Disconnect the motor cables.	 xx1200001066
5	Remove the cable gland cover. Make sure the gasket is not damaged.  Tip Make a note in which direction the cable gland hole is facing, if the motor will be removed too. The motor shall be refitted in the same position.	 xx1200001067
6	Use caution and pull out the motor cables.	

Continues on next page

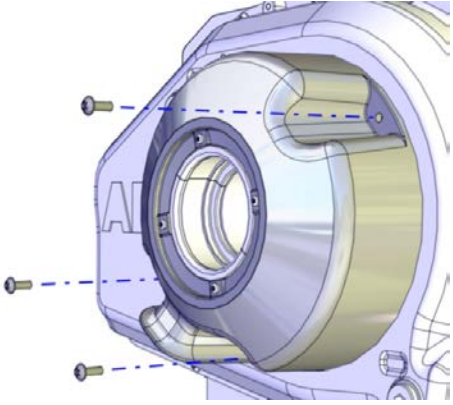
Removing the cable harness - wrist and upper arm

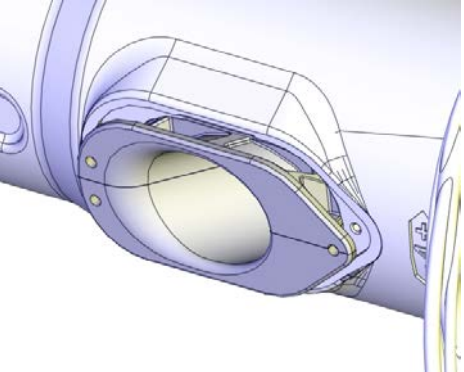

	Action	Note
1	<p>Remove the cover.</p> <p> Note</p> <p><i>Foundry Plus:</i> Use caution not to damage the gasket, not to loose the washers on the cover sealing or not to loose the inserts fitted on the cover.</p>	 <p>xx120000045</p>
2	<p>If the cabling is to be replaced by a new cable harness, remove the cover insert to use it on the new cabling.</p>	 <p>xx1700001803</p>
3	<p>If used, loosen the insert.</p>	 <p>xx1700000690</p>

Continues on next page

4 Repair

4.4.1 Removing the cable harness

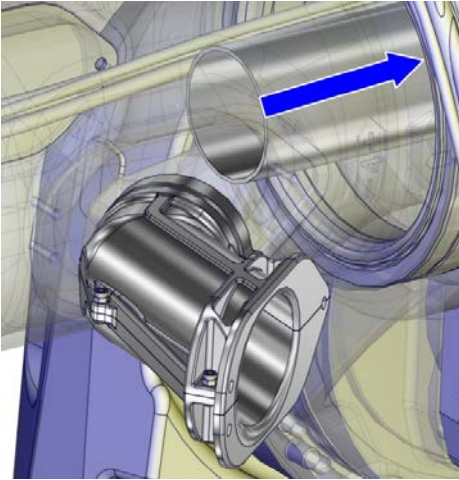
Continued

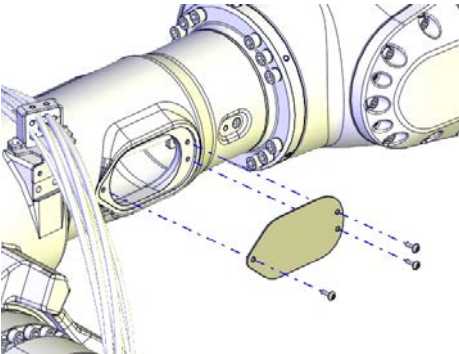
	Action	Note
4	If used, push the DressPack tube a little backwards.	 xx140000720
5	 Tip Use tape and tie the axis-5 and axis-6 connectors and carrier into a bundle (if not already done). This is done to facilitate the removal and to avoid damaging the parts. This will also make it easier to run the cable harness through the inside of the upper arm.	 xx130000668
6	Remove the side cover on the arm tube.	 xx130000557

Continues on next page

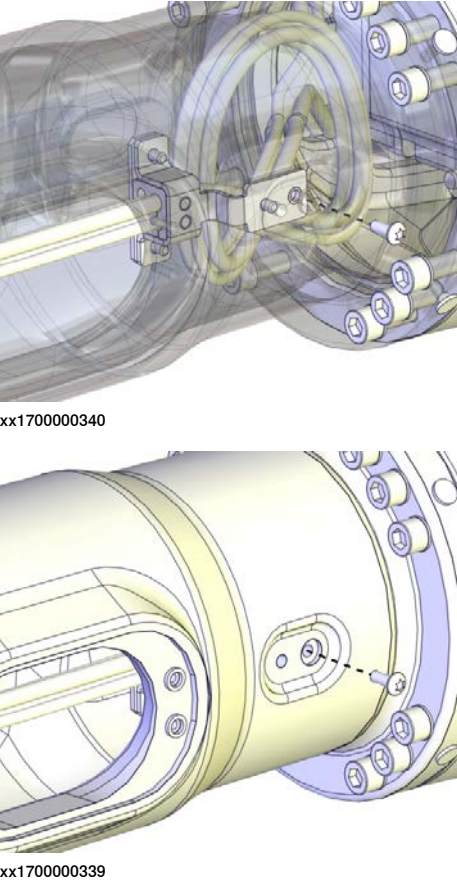
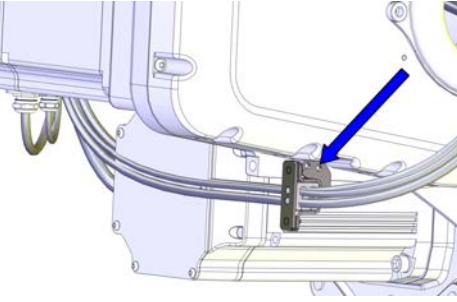
	Action	Note
7	<p>Unscrew the attachment screw that secures the axis-4 metal clamp inside the arm tube.</p> <p> Note</p> <p>The screw is reached from outside the upper arm.</p>	 <p>xx170000340</p> <p>xx170000339</p>
8	<p>Remove the arm house metal clamp.</p>	 <p>xx130000543</p>

Continues on next page



4 Repair

4.4.1 Removing the cable harness

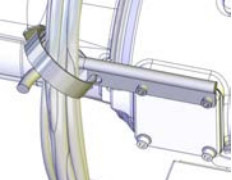
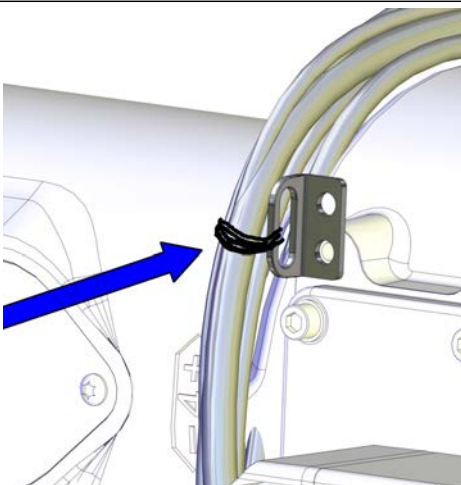
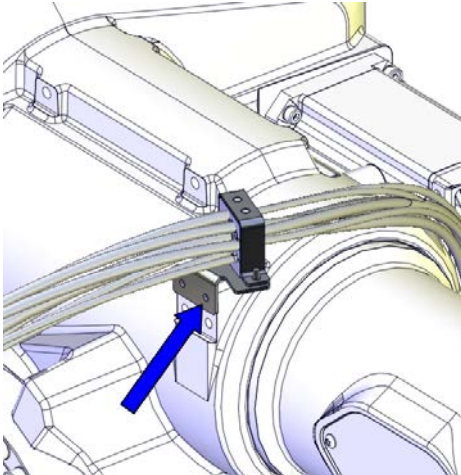
Continued

	Action	Note
9	<p>Cut the cable tie at the cable fixing bracket.</p> <p> Note</p> <p>If DressPack is fitted, the cable fixing bracket is replaced by the cable guide.</p>  <p>xx1300001973</p> <p>Cable guide.</p>	 <p>xx1300000544</p> <p>Cable fixing bracket.</p>
10	<p>Remove the metal clamp on top of the arm house.</p>	 <p>xx1300000541</p>

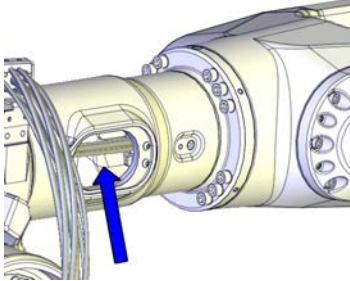
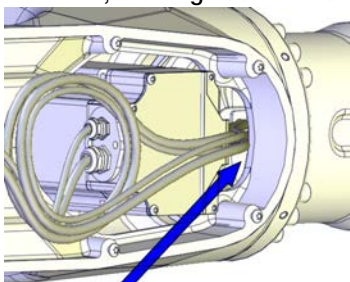
Continues on next page

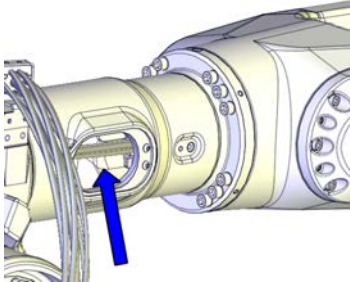
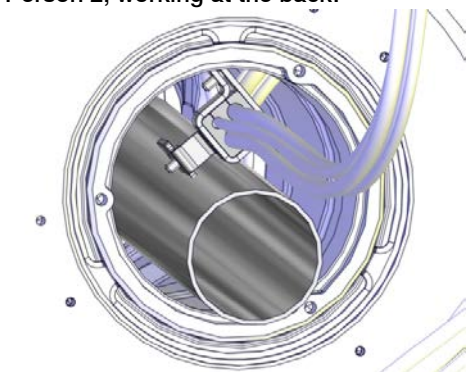
	Action	Note
11	<p>Remove the cable harness out from the wrist.</p> <p> Tip</p> <p>This step is best performed by two persons working together:</p> <ul style="list-style-type: none"> • Person 1: Put one hand inside the side hole and take a hold of the cable harness. • Person 2: Take a hold on the cable harness inside the wrist. • Together: Move the cable harness past the axis-5 motor and into the arm tube. 	<p>Person 1, working at the side hole:</p>  <p>xx130000745</p> <p>Person 2, working at the wrist:</p>  <p>xx130000746</p>
12	<p>Remove the cable harness out of the arm tube, at the back of the upper arm.</p> <p> Tip</p> <p>This step is best performed by two persons working together:</p> <ul style="list-style-type: none"> • Person 1: Put one hand inside the side hole and take a hold of the cable harness. • Person 2: Take a hold on the cable harness at the back of the robot. • Together: Move the cable harness out of the arm tube. 	<p>Person 1, working at side hole:</p>  <p>xx130000745</p> <p>Person 2, working at the back:</p>  <p>xx140002561</p>

Continues on next page

4 Repair

4.4.1 Removing the cable harness

Continued



Removing the cable harness - base, frame and lower arm

These procedures describes how to remove the cable harness from base, frame and lower arm.

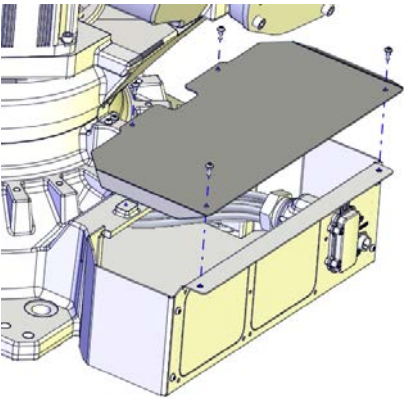
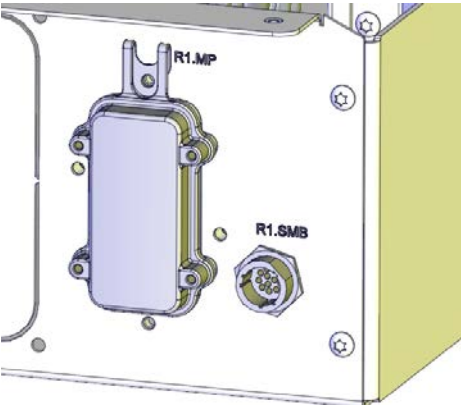
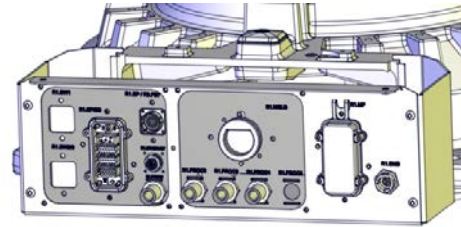
Preparations before removing the cable harness in the base

	Action	Note
1	 DANGER Make sure that all supplies for electrical power, hydraulic pressure, and air pressure are turned off.	
2	Remove the base cover.	 xx130000561
3	Disconnect connectors: <ul style="list-style-type: none">• R1.MP• R1.SMB	 xx130000591
4	If used, disconnect the DressPack hoses in the base.	 xx140000366

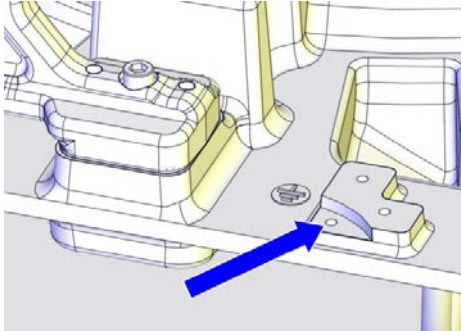
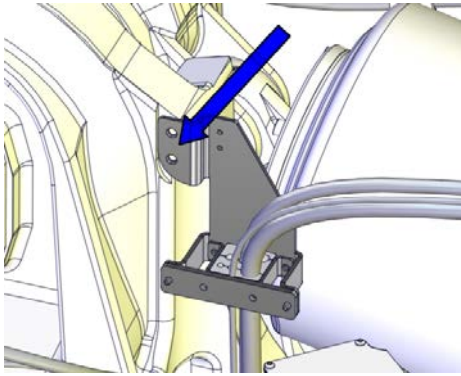
Continues on next page

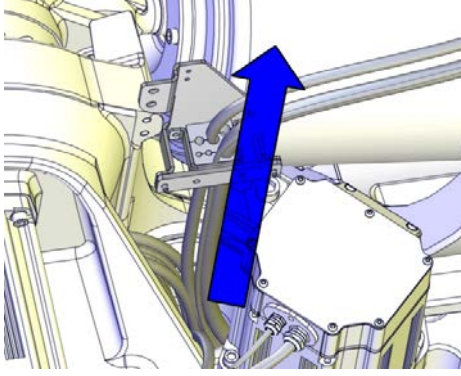
	Action	Note
5	Disconnect the earth cable.	<p>Screw dimension : M6x16 Washer dimension : 6.4x17x3</p>  <p>xx140000354</p>
6	<p>If used, remove the attachment screws that secure the bracket. This is done to facilitate removal of the DressPack hoses.</p>	 <p>xx140000078</p>
7	<p>If used, use caution and pull out the DressPack hoses through the protection tube in the base.</p> <p> Note</p> <p>There is no need to pull out the DressPack cables at this point!</p>	 <p>xx140000088</p>

Disconnecting the axis-1 and axis-2 motor cables

	Action	Note
1	<p> DANGER</p> <p>Make sure that all supplies for electrical power, hydraulic pressure, and air pressure are turned off.</p>	

4 Repair

4.4.1 Removing the cable harness

Continued

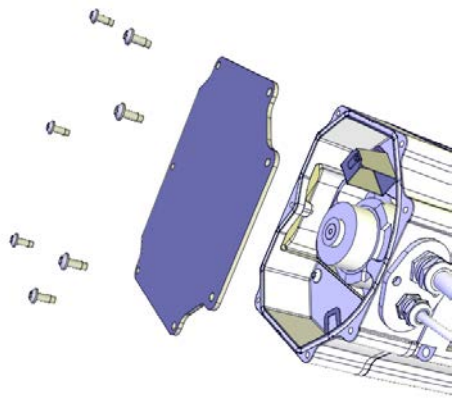
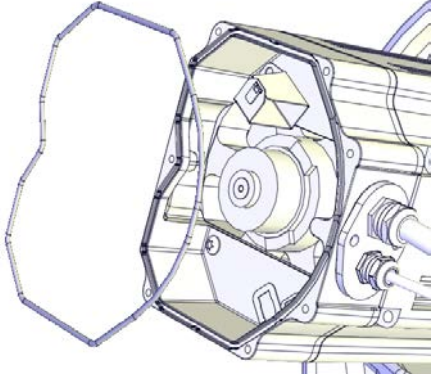
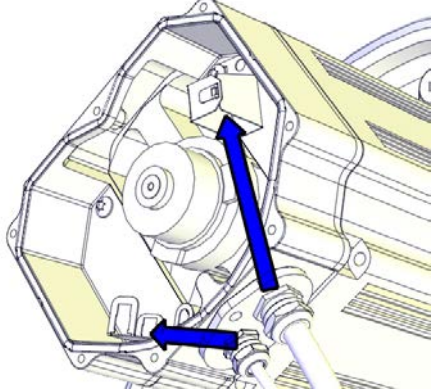

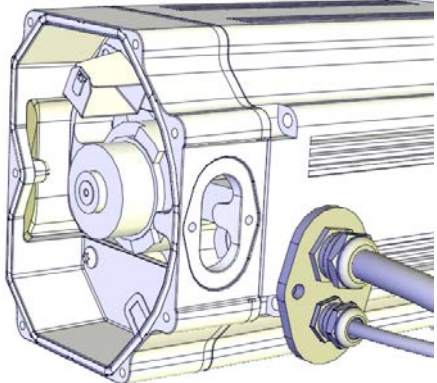

	Action	Note
2	Unscrew the attachment screws and washers and remove the motor cover.	 <p>xx1200001135</p>
3	Make sure the o-ring is present.	 <p>xx1200001070</p>
4	Disconnect the motor cables.	 <p>xx1200001066</p>

Continues on next page

4.4.1 Removing the cable harness
Continued

	Action	Note
5	<p>Remove the cable gland cover. Make sure the gasket is not damaged.</p> <p> Tip</p> <p>Make a note in which direction the cable gland hole is facing, if the motor will be removed too. The motor shall be refitted in the same position.</p>	 <p>xx1200001067</p>
6	Use caution and pull out the motor cables.	

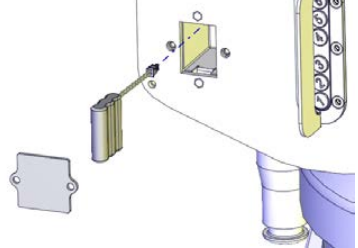
Preparations before disconnecting the SMB unit

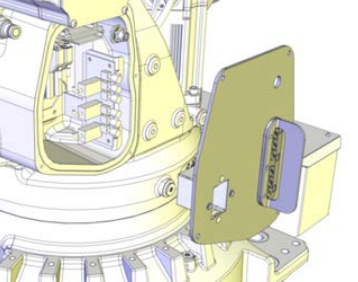
	Action	Note
1	<p> DANGER</p> <p>Make sure that all supplies for electrical power, hydraulic pressure, and air pressure are turned off.</p>	
2	<p> ELECTROSTATIC DISCHARGE (ESD)</p> <p>The unit is sensitive to ESD. Before handling the unit please read the safety information in the section The unit is sensitive to ESD on page 54</p>	
3	Open the small cover on the SMB cover, disconnect the battery cable and remove the battery.	 <p>xx1300000829</p>
4	<p>Remove the SMB cover.</p> <p> CAUTION</p> <p>Clean cover from metal residues before opening. Metal residues can cause shortage on the boards which can result in hazardous failures.</p>	 <p>xx1300000669</p>



Continues on next page

4 Repair

4.4.1 Removing the cable harness

Continued

Disconnecting the brake release unit

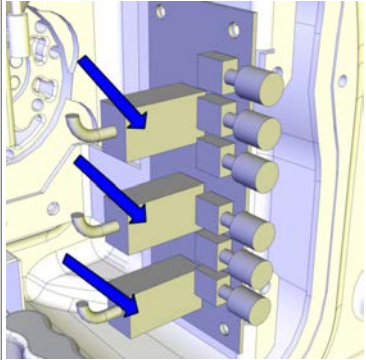
	Action	Note
1	 DANGER Make sure that all supplies for electrical power, hydraulic pressure, and air pressure are turned off.	
2	 ELECTROSTATIC DISCHARGE (ESD) The unit is sensitive to ESD. Before handling the unit please read the safety information in the section <i>The unit is sensitive to ESD on page 54</i>	
3	Take a picture or make notes of how the robot cabling is positioned in regard to the brake release board.	
4	Remove the connectors X8, X9 and X10 from the brake release board.	 xx130000670

Removing the cable harness in the base

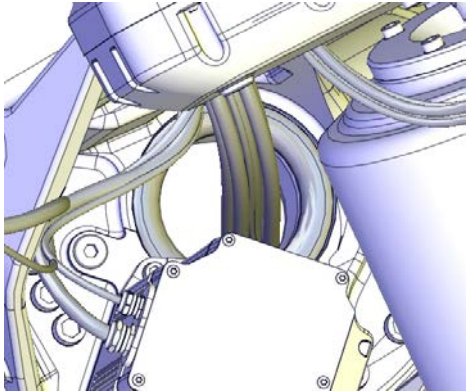
	Action	Note
1	If equipped with DressPack, pull out the DressPack cables through the protection tube and place them carefully over the balancing device.	
2	Pull out the robot cable harness through the protection tube.	 xx130000732
3	Place the cable harness over the balancing device.	

Continues on next page

Removing the cable harness in the frame

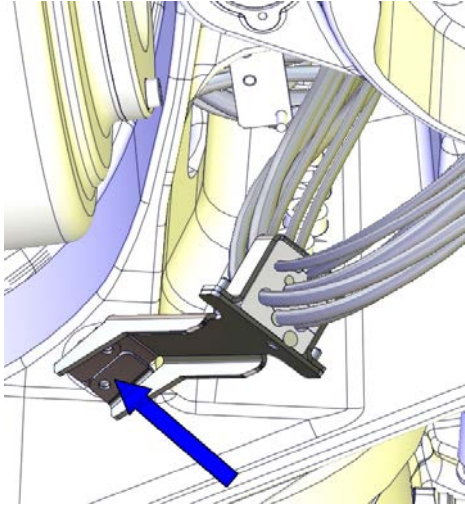
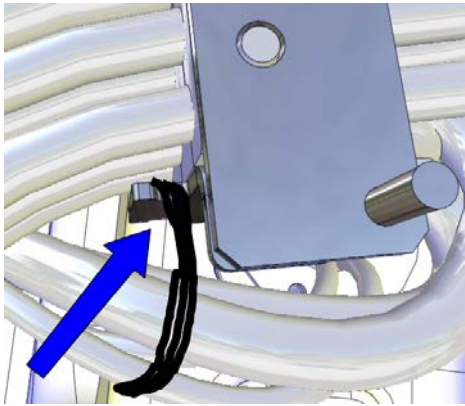
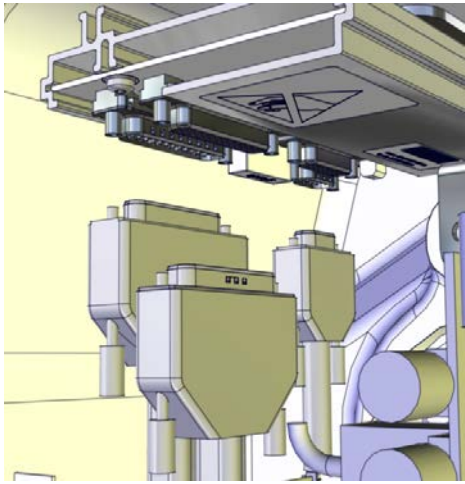

	Action	Note
1	Unscrew the attachment screws that hold the metal clamp frame.	 <p>xx130000542</p>
2	Cut the cable tie inside the frame recess.	 <p>xx1200001237</p>
3	Disconnect connectors on the SMB unit.	 <p>xx1300001114</p>

Continues on next page

4 Repair

4.4.1 Removing the cable harness

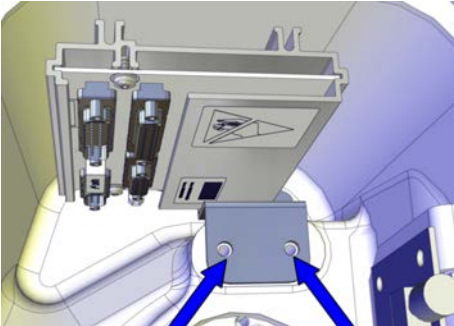
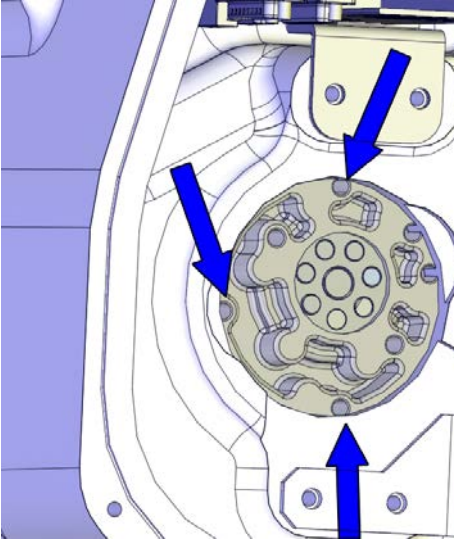

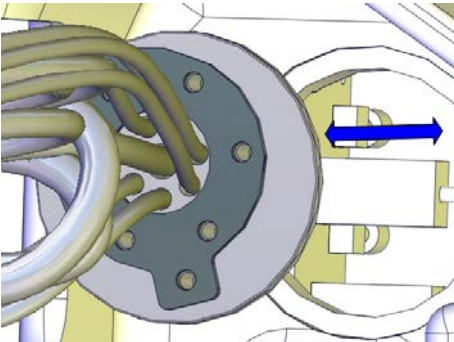
Continued

	Action	Note
4	<p>Unscrew the screws and washers that holds the bracket with the SMB unit, and remove the SMB unit.</p> <p>Put the SMB unit in an ESD bag until it shall be refitted.</p>	 <p>xx130000730</p>
5	<p>Unscrew the attachment screws that hold the SMB/BU cover from inside the SMB recess.</p>	 <p>xx130000655</p>
6	<p>Use caution and pull out the cable harness from the SMB recess.</p> <p> Note</p> <p>The parts are sealed with Sikaflex. Remove the part carefully.</p>	 <p>xx130000560</p>

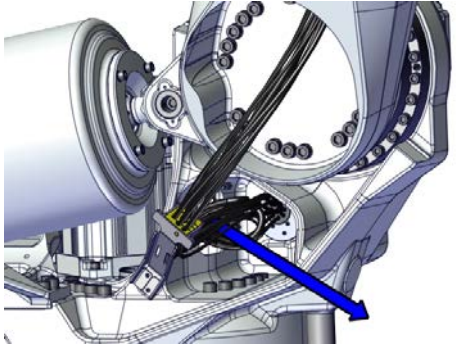
Continues on next page

	Action	Note
7	<p>Use caution and pull out the cable harness through the hole in the frame.</p> <p> Tip</p> <p>Keep a hand on the cable protection while pulling out the cable harness from the base, so it does not come loose.</p>	 <p>xx1700001587</p>

Removing the cable harness in the lower arm

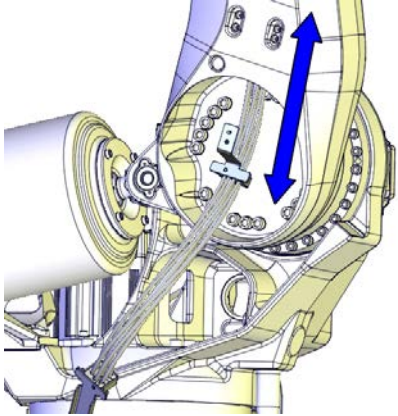
	Action	Note
1	<p>Loosen the axis-2 lower arm metal clamp and the axis-3 lower arm metal clamp located on the inside of the lower arm by removing the attachment screws.</p> <p> Note</p> <p>The screws are reached from the outside of the lower arm.</p>	 <p>xx1300000540</p>
2	<p>Use caution and pull the cable harness out.</p>	 <p>xx1300000733</p>

4 Repair

4.4.2 Refitting the cable harness

4.4.2 Refitting the cable harness

Location of the cable harness

The cable harness is located as shown in the figure.

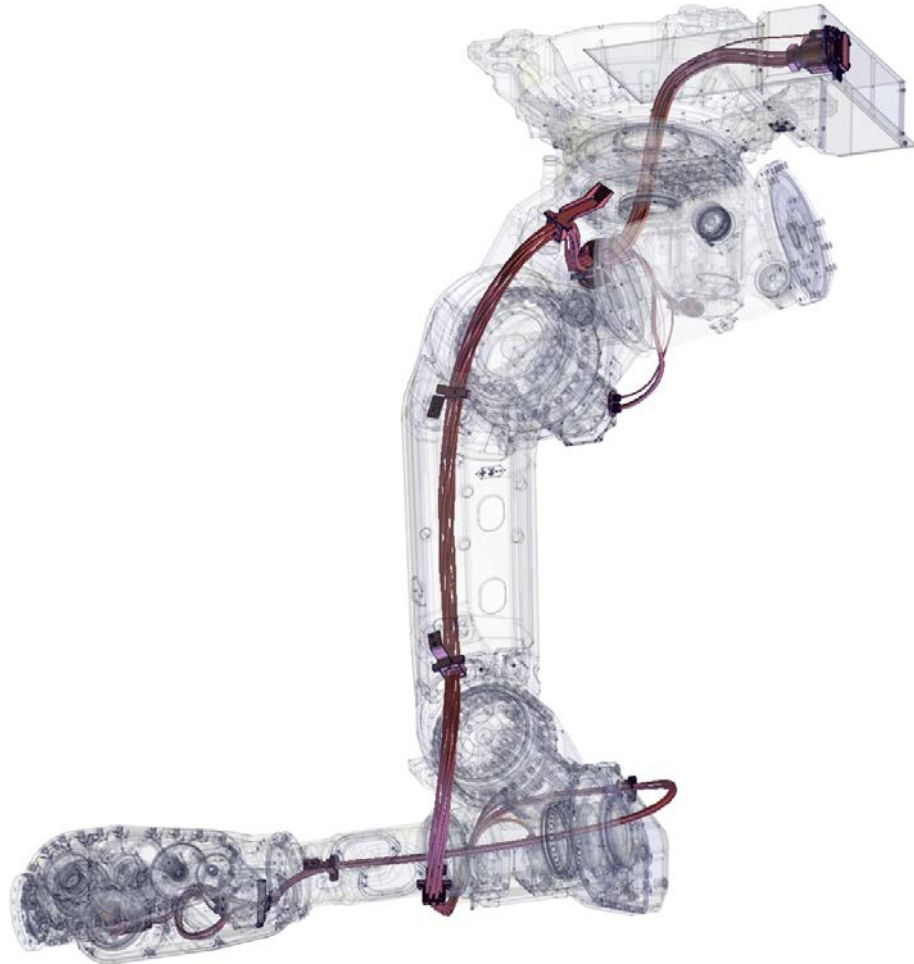

xx1600002063

Spare part

Spare part	Spare part number	Note
Cable harness	See <i>Product manual, spare parts - IRB 6700/IRB 6700Inv</i>	
Cover insert	3HAC048520-001	Replace if damaged.
Cable protection, PU rubber	3HAC055411-001	Replace if damaged.

Continues on next page

Required tools and equipment

Equipment, etc.	Article number	Note
Standard toolkit	-	Content is defined in section Standard toolkit on page 724 .

Consumables

Consumable	Article number	Note
Grease	3HAC042536-001	Shell Gadus S2 Used to lubricate o-rings.
O-ring	21522012-429	D=84.5x3 Used on the SMB/BU cover.
O-ring	3HAC054692-002	Used on axis-1 motor cover.
	3HAC054692-002	D=169.5x3 Used on axis-2 motor cover.
	3HAC054692-002	D=169.5x3 Used on axis-3 motor cover
	3HAC054692-001	D=119x3 Used on axis-4 motor cover.
	3HAC054692-001	D=119x3 Used on axis-5 motor cover.
Gasket	3HAC033489-001	Used on axis-6 motor cover.
Cable ties	-	
Weatherstrip	3HAC053986-001	

Robot position

If the robot axes have been re-positioned after the cable harness has been removed, make sure to restore the initial robot position before refitting the cable harness. See [Preparations before removing the cable harness on page 218](#).

Refitting the cable harness - base, frame and lower arm

These procedures describes how to refit the cable harness in base, frame and lower arm.

Preparations before refitting the cable harness in the base, frame and lower arm

**Note**





Handle the cables carefully to avoid any scratches or damage that lead to leakage when the system is pressurized.

Continues on next page

4 Repair

4.4.2 Refitting the cable harness

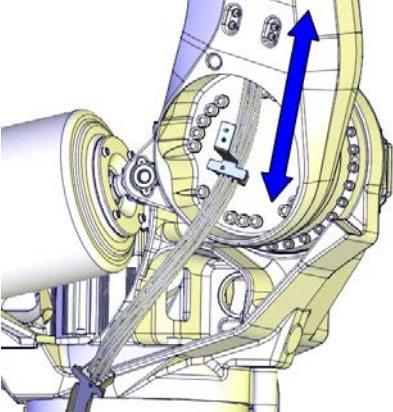
Continued

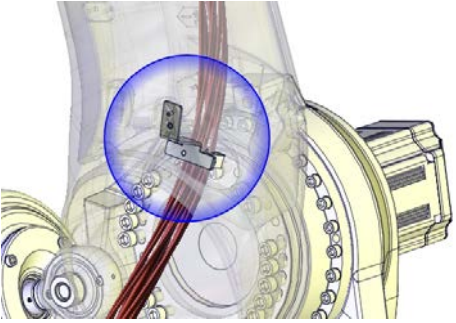
	Action	Note
1	<p> DANGER</p> <p>Turn off all:</p> <ul style="list-style-type: none">• electric power supply• hydraulic pressure supply• air pressure supply <p>to the robot, before entering the safe-guarded space.</p>	
2	<p>Tie the axis-5 and axis-6 connectors and carrier into a bundle with tape. This is done to facilitate the procedure and to avoid damaging the parts during the procedure. This will also make it easier to run the cable harness through the inside of the robot.</p>	 <p>xx130000668</p>
3	<p>Run the cable harness through the lower arm.</p>	 <p>xx130000733</p>
4	<p>Secure the axis-2 lower arm cable bracket.</p> <p> Note</p> <p>Do not secure the axis-3 lower arm cable bracket at this point.</p> <p> Note</p> <p>Screws are reached from the outside of the lower arm.</p>	 <p>xx130000734</p>

Continues on next page

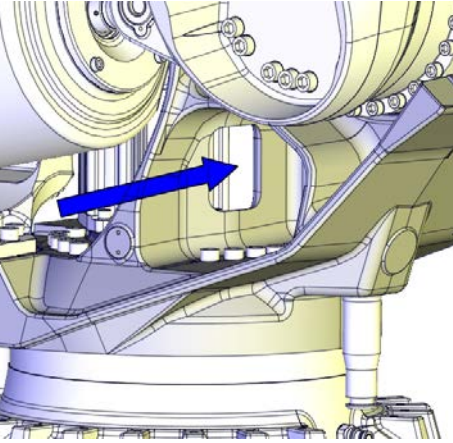
	Action	Note
5	<p>Run the cable harness into the hole in the frame in this order:</p> <ul style="list-style-type: none"> • R1.MP • R1.SMB • R2.MP2 • R2.MP1 	 <p>xx130000735</p>

Refitting the cable harness in the base

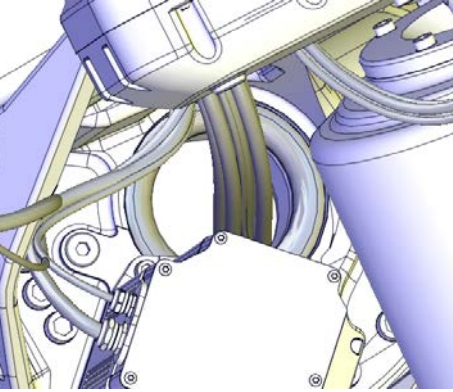
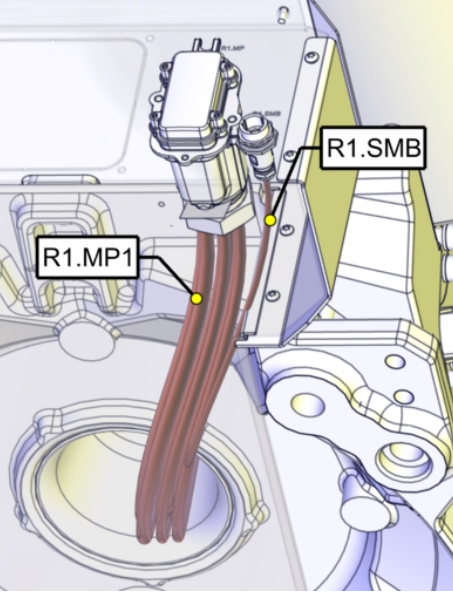
	Action	Note
1	<p>Run the cables through the protection tube in this order:</p> <ul style="list-style-type: none"> • R1.MP • R1.SMB <p>If necessary, lubricate the cables with grease to make them run more smoothly.</p>	 <p>xx130000732</p>
2	<p>Run the cables correctly aligned:</p> <ul style="list-style-type: none"> • Make sure that the cables are not twisted. Each cable must be in line with its position on the base plate. • Make sure that the R1.SMB cable will run on the correct side of the R1.MP1, see the figure. 	 <p>xx130000736</p>

Continues on next page

4 Repair

4.4.2 Refitting the cable harness

Continued

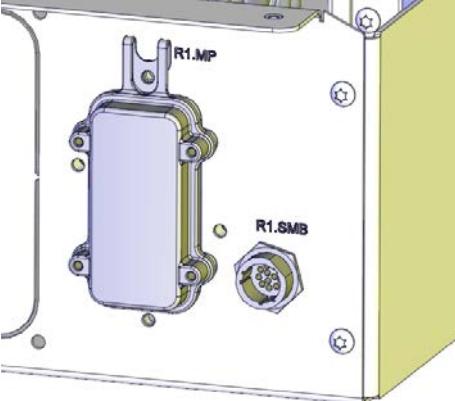
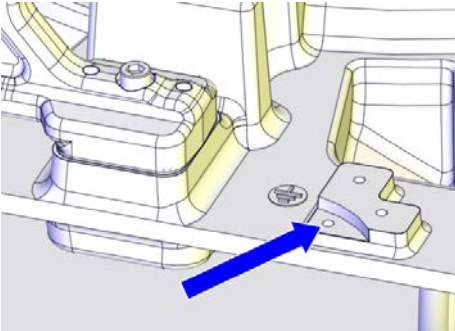
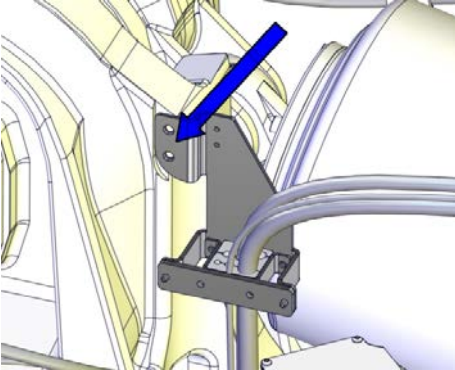
	Action	Note
3	Make sure that the markings on the cables are facing the base cover, when connected.	
4	Connect connectors R1.MP and R1.SMB.	<p>Tightening torque for R1.SMB: 10 Nm.</p>  <p>xx130000591</p>
5	Connect the earth cable.	<p>Screw dimension: M6x16. Washer dimension: 6.4x17x3.</p>  <p>xx140000354</p>
6	If used, run the DressPack cables through the protection tube in the base.	
7	If used, run the DressPack hoses through the protection tube in the base. Make sure that the hoses are running correctly and are not twisted!	
8	If used, fit the bracket that hold the DressPack to the frame.	 <p>xx140000078</p>

Continues on next page

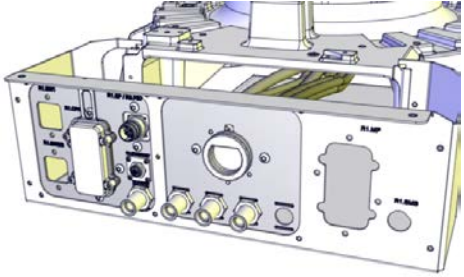
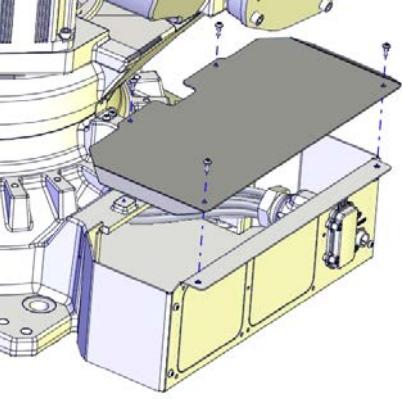
	Action	Note
9	If used, connect the DressPack cable package on the base plate.	 <p>xx120000052</p>
10	Refit the base cover.	 <p>xx1300000561</p>

Refitting the cable harness in the frame

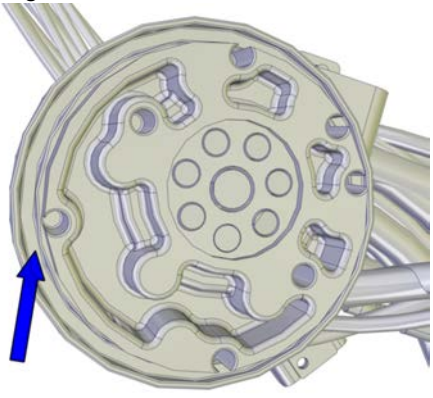



	Action	Note
1	Remove the old sealant without damaging the equipment before removing the o-ring located on the SMB/BU cover.	<p>O-ring, 21522012-429</p>  <p>xx1300000737</p> <p>The figure shows the position of the o-ring.</p>
2	Check the o-ring and replace if damaged.	
3	Wipe clean the contact surfaces and apply new sealant on top of the new o-ring after positioning it in the groove.	<p>Sealant (grey): 3HAC026759-001 (Sikaflex 521FC)</p>

Continues on next page

4 Repair

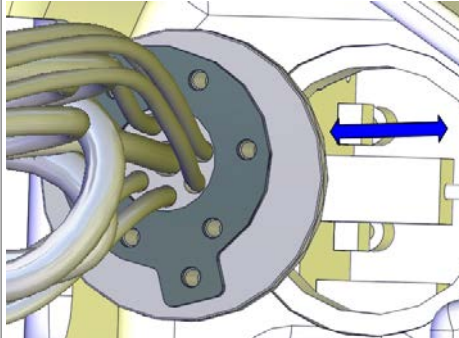
4.4.2 Refitting the cable harness

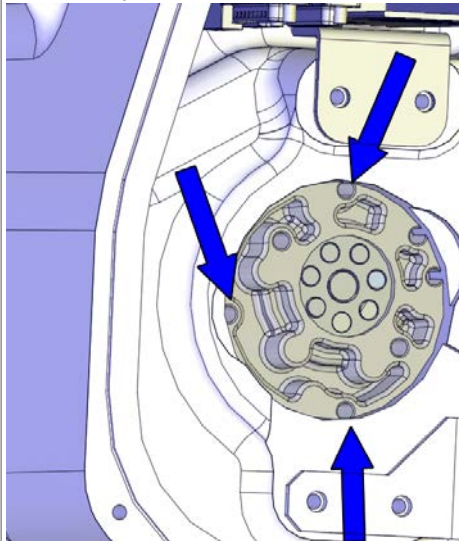
Continued

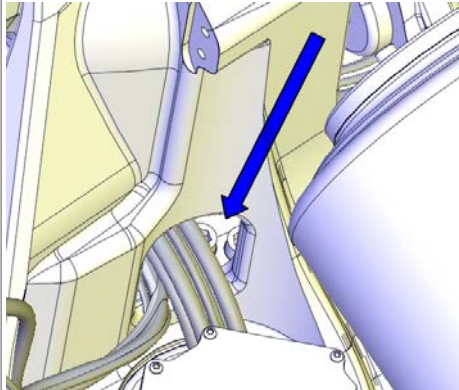
	Action	Note
4	Run the SMB/BU cables into the SMB recess.	 xx130000560
5	<p>Fit the SMB/BU cover in its hole with the attachment screws from inside the SMB recess without damaging the o-ring.</p> <p> Note</p> <p>Do not tighten the screws fully! It must still be possible to adjust the position of the cable harness by rotating the SMB/BU cover in its hole a little.</p>	<p>Screws: 3 pcs.</p>  xx130000655
6	<p>Adjust the cables running through the hole in the frame by carefully moving the SMB/BU cover on its screws, while at the same time checking the position of the cable harness through the hole.</p> <p> Note</p> <p>The cables must be placed so that they don't rub against any part of the robot.</p>	 xx130000593

Continues on next page

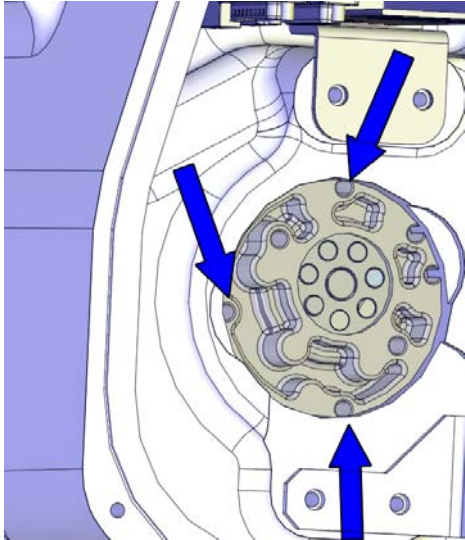
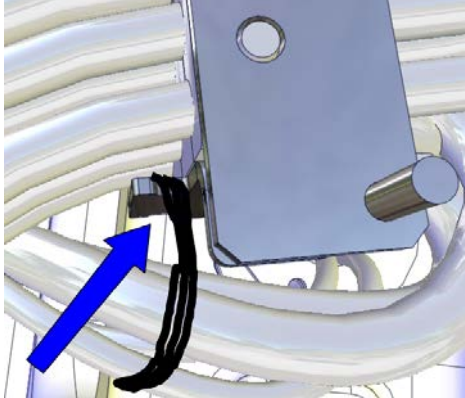
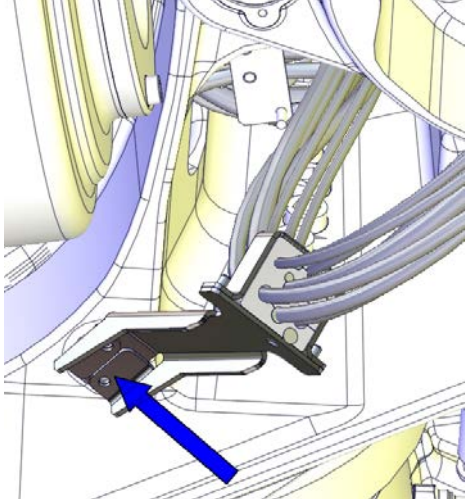
	Action	Note
7	Secure the SMB/BU cover with its three attachment screws from inside the SMB/BU recess.	 <p>xx130000655</p>
8	Secure the cable harness to the bracket inside the frame hole, with a cable tie.	 <p>xx1200001237</p>
9	Refit the frame metal clamp.	 <p>xx130000542</p>



Continues on next page

4 Repair

4.4.2 Refitting the cable harness

Continued

Refitting and reconnecting the SMB and BU units

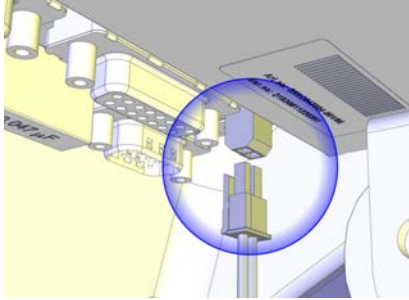
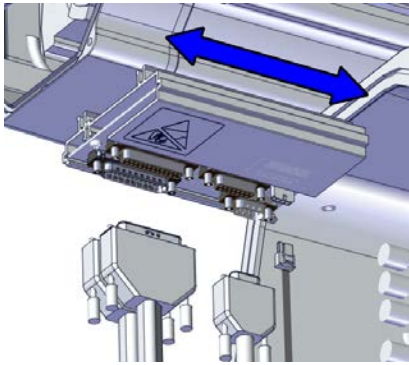
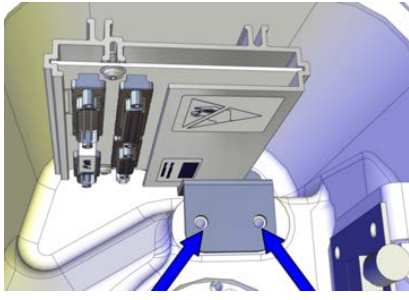
Action	Note
<p>1</p> <p> DANGER</p> <p>Make sure that all supplies for electrical power, hydraulic pressure, and air pressure are turned off.</p>	
<p>2</p> <p> ELECTROSTATIC DISCHARGE (ESD)</p> <p>The unit is sensitive to ESD. Before handling the unit please read the safety information in the section The unit is sensitive to ESD on page 54</p>	
<p>3</p> <p>Connect the battery cable to the SMB unit. Make sure the lock snaps into place during refitting.</p>	 <p>xx1300000729</p>
<p>4</p> <p>Connect all connectors to the SMB board:</p> <ul style="list-style-type: none">• R1.SMB1-3, R1.SMB4-6 and R2.SMB	 <p>xx1300000728</p>
<p>5</p> <p>Push the SMB unit carefully into position and fit the bracket that secures the SMB unit.</p>	 <p>xx1300000730</p>

Continues on next page

4.4.2 Refitting the cable harness
Continued

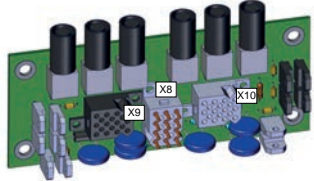
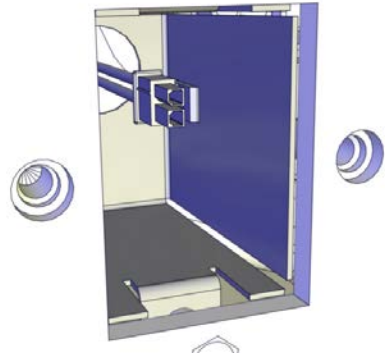
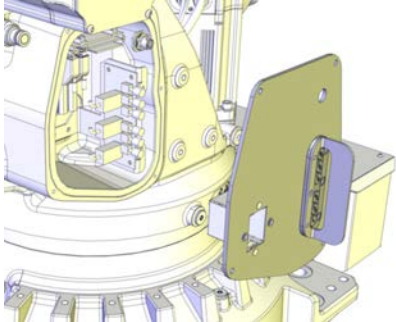
	Action	Note
6	<p>If disconnected, reconnect the connectors X8, X9 and X10 to the brake release board. Be careful not to damage the sockets or pins. Make sure the connector and its locking arms are snapped down properly.</p>	 <p>xx1700000978</p>
7	<p>Pull out the battery cable through the recess for the battery.</p>	 <p>xx1300000834</p>
8	<p>Secure the SMB cover with the attachment screws. If cabling is used for 7th axis (option), refit the connector R2.FB7 to the SMB cover and tighten with 6 Nm.</p>	 <p>xx1300000669</p>

Reconnecting the axis-1 and axis-2 motor cables

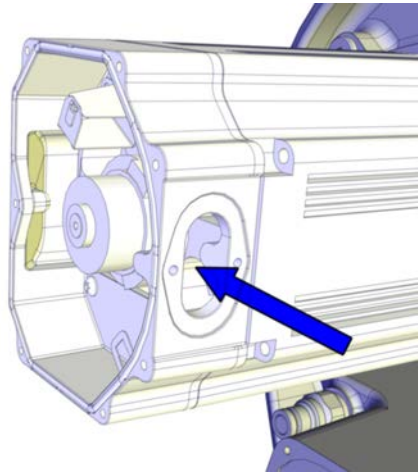

	Action	Note
1	<p>Push the motor cables through the cable gland opening.</p>	 <p>xx1300000738</p>

Continues on next page



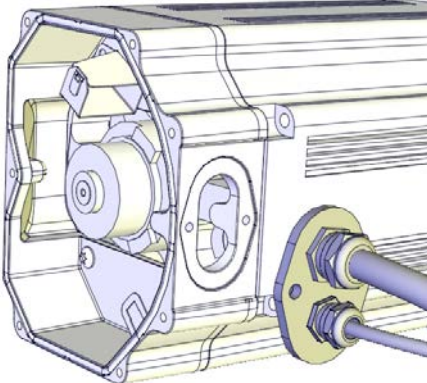
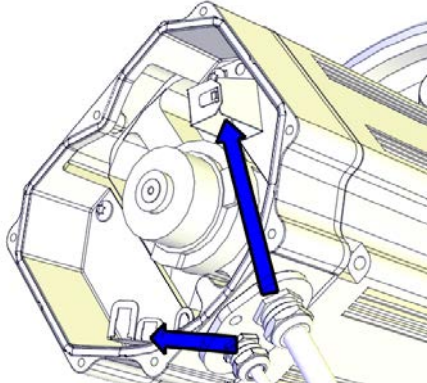

4 Repair

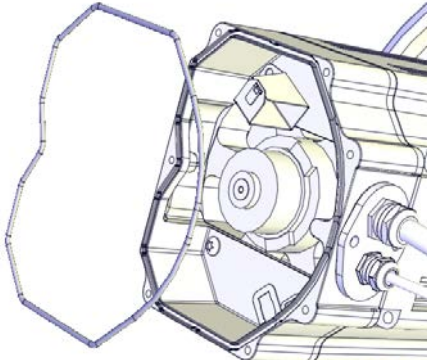
4.4.2 Refitting the cable harness



Continued

	Action	Note
2	<p>Refit the cable gland cover.</p> <p> Note Replace the gasket if damaged.</p>	 <p>xx1200001067</p>
3	<p>Connect the motor cables.</p> <p>Connect in accordance with the markings on the connectors.</p>	 <p>xx1200001066</p>
4	<p>Inspect the o-ring.</p> <p> Note Replace if damaged.</p>	<p>O-ring, axis-1: 3HAC054692-002 O-ring, axis-2: 3HAC054692-002 O-ring, axis-3: 3HAC054692-002 O-ring, axis-4: 3HAC054692-001</p>  <p>xx1200001070</p>
5	<p>Wipe clean o-ring and o-ring groove.</p>	

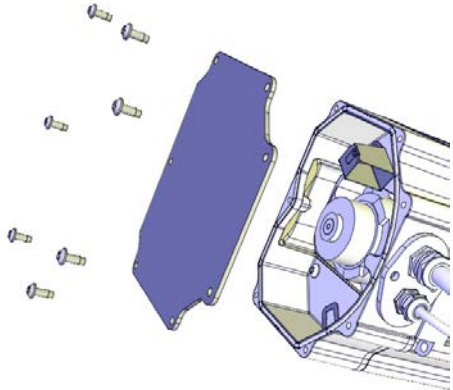
Continues on next page

	Action	Note
6	<p>Refit the o-ring.</p> <p> Tip</p> <p>Lubricate the o-ring with some grease for a better fitting in the groove.</p>	
7	<p> CAUTION</p> <p>When fitting the motor cover, make sure that none of the cables inside will be damaged.</p>	
8	<p>Refit the motor cover with it's attachment screws.</p> <p> Note</p> <p>Do not reuse the self-threading attachment screws. Replace with standard attachment screws or the threads will be damaged.</p> <p> Note</p> <p>Make sure the o-ring is undamaged and properly fitted.</p>	<p>Attachment screws: M5x12 8.8 (7 pcs)</p>  <p>xx1200001135</p>
9	<p>Make sure that the covers are tightly sealed.</p>	

Refitting the cable harness - lower arm





	Action	Note
1	<p> Tip</p> <p>Use tape and tie the axis-5 and axis-6 connectors and carrier into a bundle (if not already done). This is done to facilitate the procedure and to avoid damaging the parts during the procedure.</p> <p>This will also make it easier to run the cable harness through the inside of the robot.</p>	 <p>xx1300000668</p>

Continues on next page

4 Repair

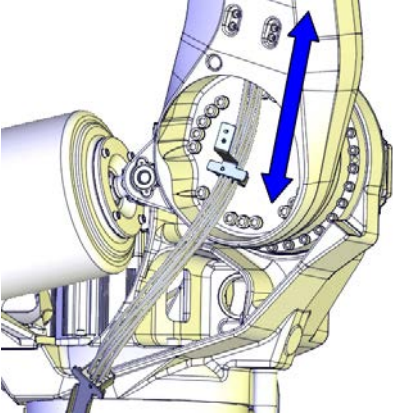
4.4.2 Refitting the cable harness

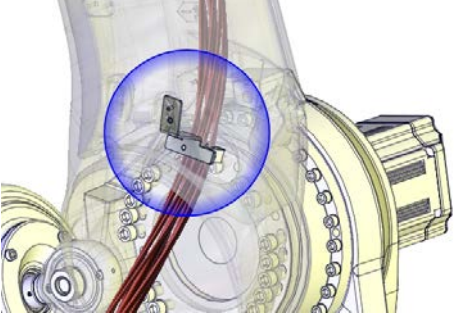
Continued

	Action	Note
2	Run the upper end of the cable harness up through the lower arm.	 xx130000733
3	Refit the axis-2 lower arm metal clamp located on the inside of the lower arm.  Note The screws are reached from the outside of the lower arm.	 xx130000734
4	Before fitting the remaining axis-3 lower arm cable bracket inside the lower arm, check that it will stay twisted a little between the metal clamps, after fitting, as shown in the figure. Do not change the position of the brackets!	 xx130000595

Continues on next page

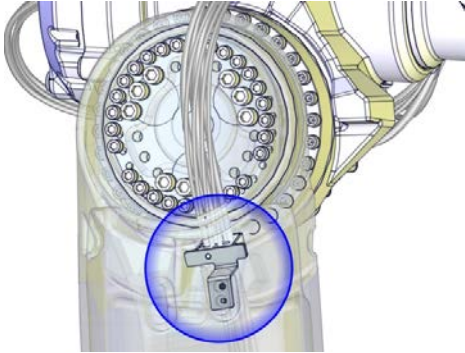
	Action	Note
5	<p>Refit the axis-3 lower arm metal clamp located on the inside of the lower arm.</p> <p> Note</p> <p>The screws are reached from the outside of the lower arm.</p>	 <p>xx1300000558</p>

Remove the transportation lock screw

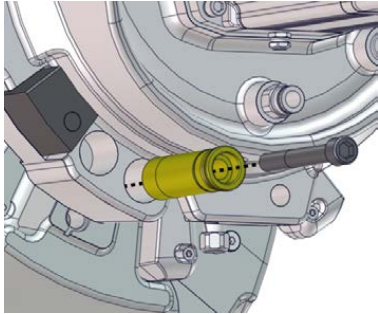
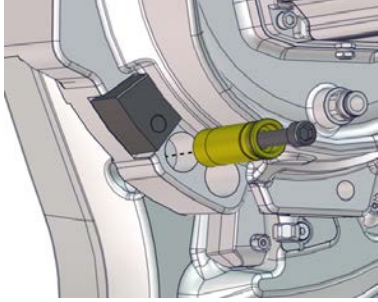
	Action	Note
1	<p>Remove the yellow sleeve and transportation lock screw from the transportation and turning position.</p>	 <p>xx1700000269</p>
2	<p>Fasten the yellow sleeve and transportation lock screw in its parking position.</p>	<p>Tightening torque: 70 Nm ±15 Nm.</p>  <p>xx1700000270</p>

Continues on next page

4 Repair



4.4.2 Refitting the cable harness

Continued



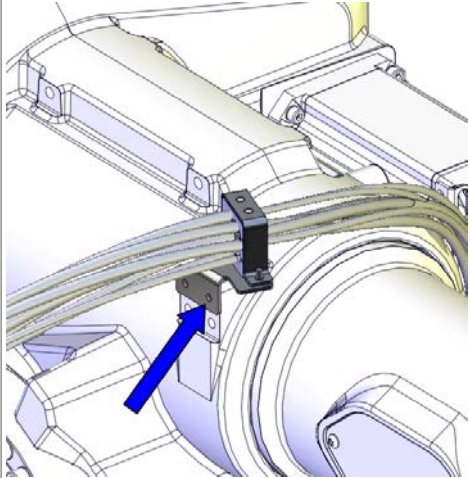
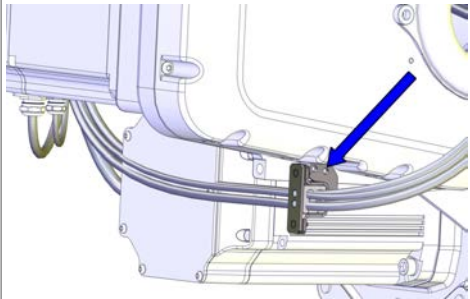

Refitting the cable harness - upper arm and wrist

These procedures describes how to refit the cable harness in upper arm and wrist.

Refitting the cable harness - upper arm

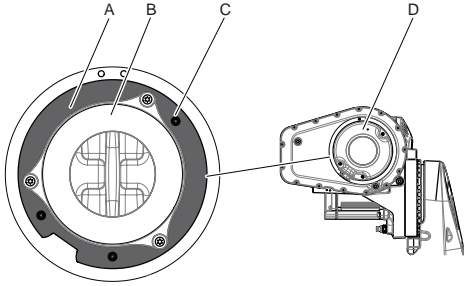
	Action	Note
1	Refit the metal clamp on top of the arm house.	 xx130000541
2	Refit the arm house metal clamp.	 xx130000543
3	Arrange the cables between the cable clamps in the upper arm.	
4	 Tip Use tape and tie the axis-5 and axis-6 connectors and carrier into a bundle (if not already done). This is done to facilitate the procedure and to avoid damaging the parts during the procedure. This will also make it easier to run the cable harness through the inside of the robot.	 xx130000668

Continues on next page

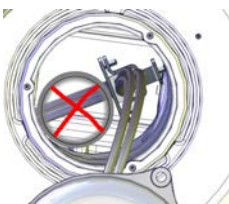
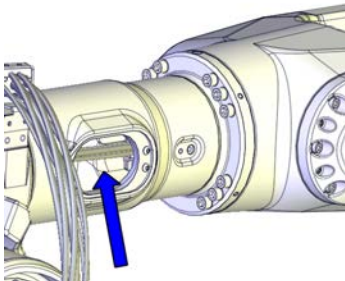
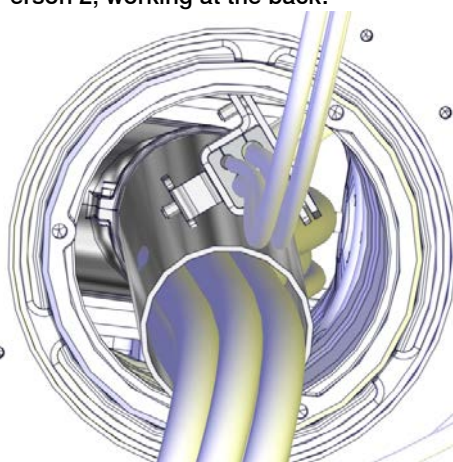

	Action	Note
5	<p>Foundry Plus: Make sure that the gasket underneath the cover is correctly fitted. Replace if damaged.</p> <p>The gasket is covered with adhesive on the side facing the upper arm cover. The three washers are pressed into the holes in the gasket. Make sure all three washers are fitted.</p>	 <p>xx140000382</p> <p>A Gasket B Cable guide C Washer D Cover</p>
6	<p>Run the cable harness through the cable guide and then into and through the upper arm tube.</p> <p> Tip</p> <p>This step is best performed by two persons working together:</p> <ul style="list-style-type: none"> • Person 1: Put one hand inside the side hole of the arm tube and take a hold of the cable harness. • Person 2: Take a hold on the cable harness at the back of the robot. • Together: Use caution and move the cable harness into the arm tube. <p> Note</p> <p>The cable harness is best placed at the upper right hand side of the DressPack tube, if used, through the arm tube.</p> <p>Do not run the cable harness into the DressPack tube!</p> <p> Note</p> <p>Do not run the cable harness into the DressPack tube, if one is fitted!</p>  <p>xx1300000820</p>	<p>Person 1, working at the side hole:</p>  <p>xx1300000745</p> <p>Person 2, working at the back:</p>  <p>xx1400000356</p>

Continues on next page

4 Repair

4.4.2 Refitting the cable harness

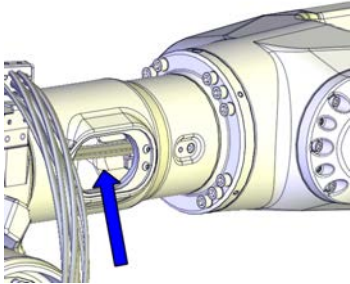
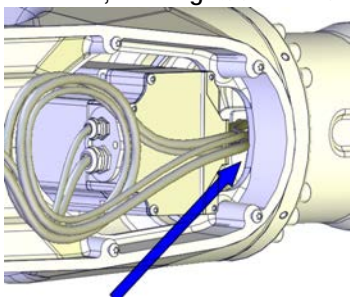
Continued

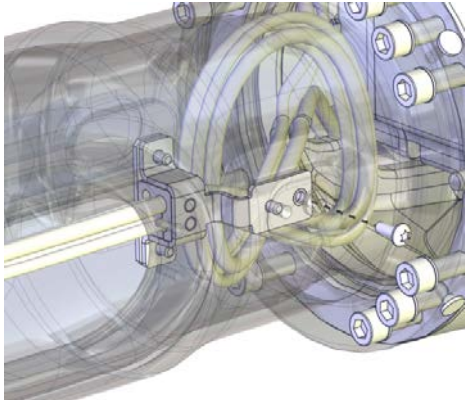
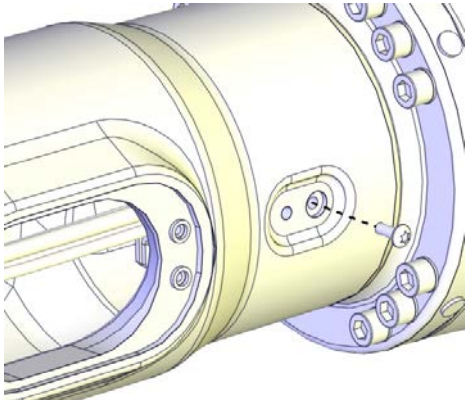
	Action	Note
7	<p>Use caution and push the cable harness into the wrist.</p> <p> Tip</p> <p>This step is best performed by two persons working together:</p> <ul style="list-style-type: none">• Person 1: Put one hand inside the side cover hole and take a hold of the cable harness.• Person 2: Take a hold of the cable harness from inside the wrist.• Together: Move the cable harness past the axis-5 motor and into the wrist.	<p>Person 1, working at the side hole:</p>  <p>xx130000745</p> <p>Person 2, working at the wrist:</p>  <p>xx130000746</p>
8	<p>Refit the metal clamp axis-4, inside the arm tube.</p> <p> Note</p> <p>The screws are reached from outside the upper arm.</p>	 <p>xx170000340</p>  <p>xx170000339</p>

Continues on next page

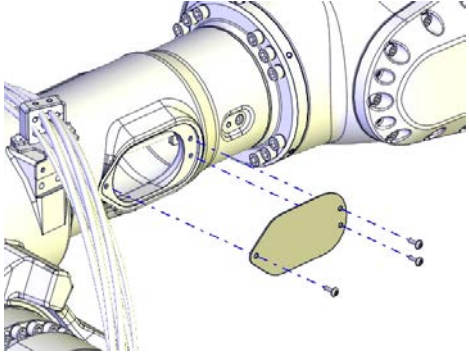
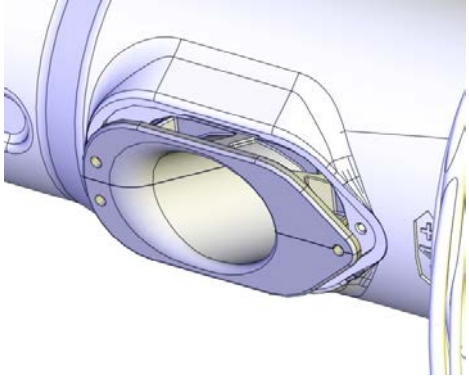
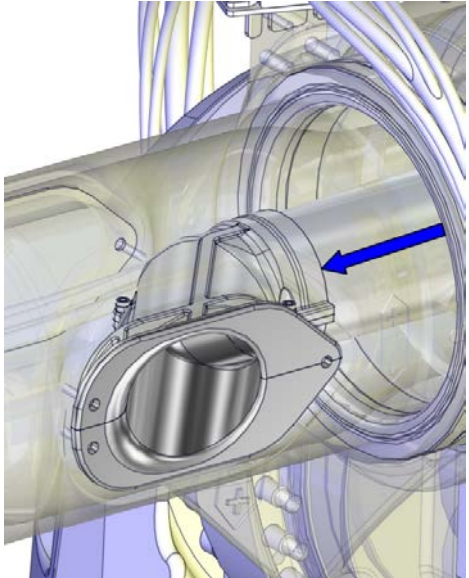

	Action	Note
9	<p>Refit the side cover.</p> <p> Note</p> <p><i>Foundry Plus:</i></p> <ul style="list-style-type: none"> • Make sure the gasket is fitted correctly on the side cover • Use attachment screws made of stainless steel to fit the side cover. 	 <p>xx130000557</p>
10	<p>If used, refit the insert that guides the DressPack cable package through the hole in the upper arm.</p>	 <p>xx170000690</p>
11	<p>If used, refit the tube containing the DressPack into the insert.</p>	 <p>xx140000092</p>

Continues on next page

4 Repair

4.4.2 Refitting the cable harness

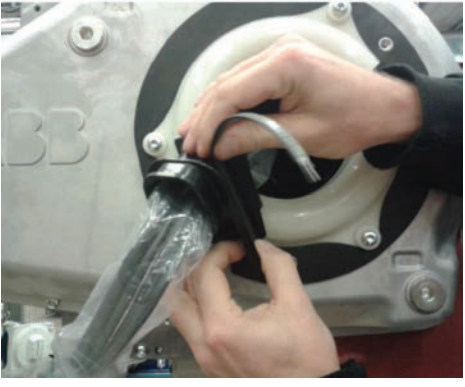

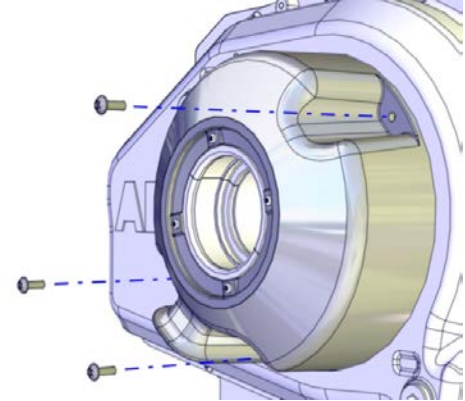
Continued

Action	Note
12 Fit the cover insert around the new cabling and secure it with a weatherstrip.	<p>Cover insert: 3HAC048520-001.</p>  <p>xx1700001803</p> <p>Weatherstrip: 3HAC053986-001.</p>  <p>xx1700001804</p>
13 <i>DressPack or Foundry Plus:</i> Refit the cover with the tube guiding ring fitted.  Note <i>Foundry Plus:</i> <ul style="list-style-type: none">• Make sure the gasket is fitted correctly• Use attachment screws made of stainless steel to fit the cover.	 <p>xx120000045</p>

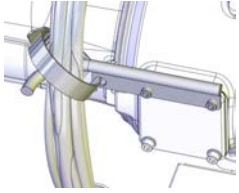
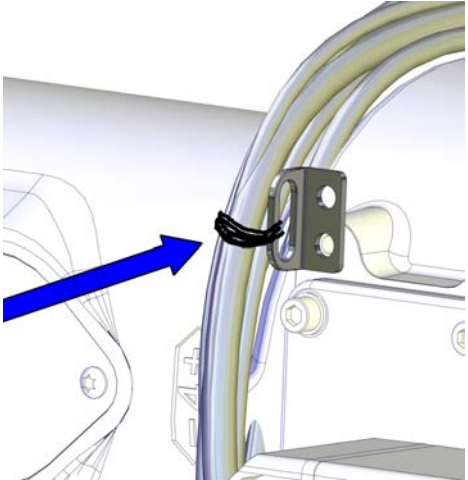
Continues on next page

	Action	Note
14	<p>Secure the cable harness to the cable fixing bracket with a cable tie.</p> <p> Note</p> <p>If DressPack is fitted, the cable fixing bracket is replaced by the cable guide.</p>  <p>xx1300001973</p>	 <p>xx1300000544</p>

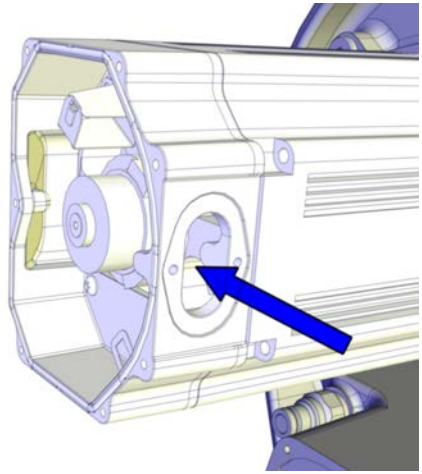
Connecting the axis-3 and axis-4 motor cables

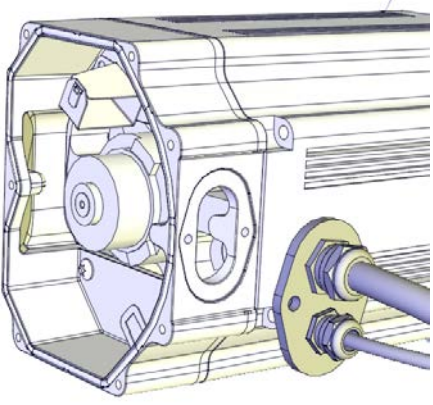



	Action	Note
1	<p>Push the motor cables through the cable gland opening.</p>	 <p>xx1300000738</p>
2	<p>Refit the cable gland cover.</p> <p> Note</p> <p>Replace the gasket if damaged.</p>	 <p>xx1200001067</p>

Continues on next page

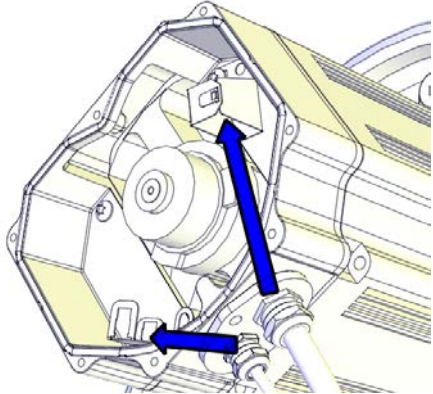

4 Repair

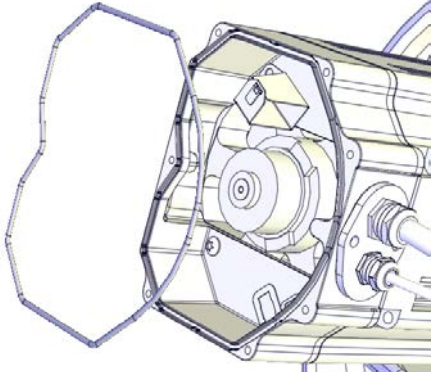
4.4.2 Refitting the cable harness



Continued

	Action	Note
3	<p>Connect the motor cables. Connect in accordance with the markings on the connectors.</p>	 <p>xx1200001066</p>
4	<p>Inspect the o-ring.</p> <p> Note Replace if damaged.</p>	<p>O-ring, axis-1: 3HAC054692-002 O-ring, axis-2: 3HAC054692-002 O-ring, axis-3: 3HAC054692-002 O-ring, axis-4: 3HAC054692-001</p>  <p>xx1200001070</p>
5	<p>Wipe clean o-ring and o-ring groove.</p>	
6	<p>Refit the o-ring.</p> <p> Tip Lubricate the o-ring with some grease for a better fitting in the groove.</p>	
7	<p> CAUTION When fitting the motor cover, make sure that none of the cables inside will be damaged.</p>	

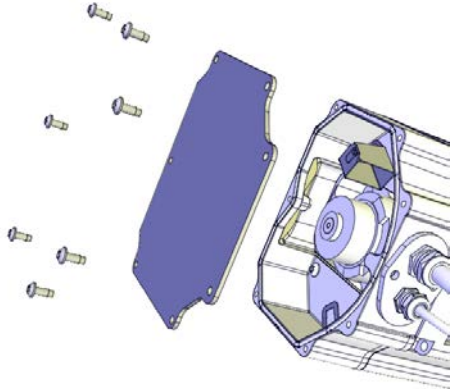
Continues on next page

	Action	Note
8	<p>Refit the motor cover with it's attachment screws.</p> <p> Note</p> <p>Do not reuse the self-threading attachment screws. Replace with standard attachment screws or the threads will be damaged.</p> <p> Note</p> <p>Make sure the o-ring is undamaged and properly fitted.</p>	<p>Attachment screws: M5x12 8.8 (7 pcs)</p>  <p>xx1200001135</p>
9	<p>Make sure that the covers are tightly sealed.</p>	

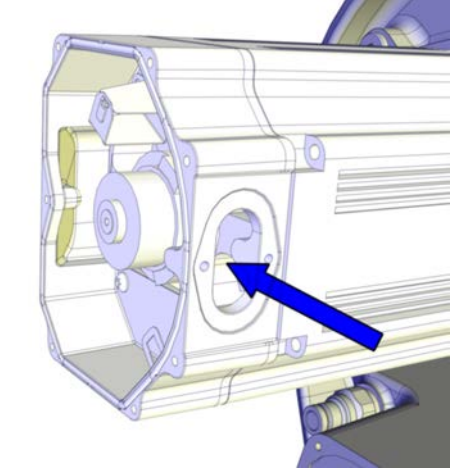
Connecting the axis-5 motor cables

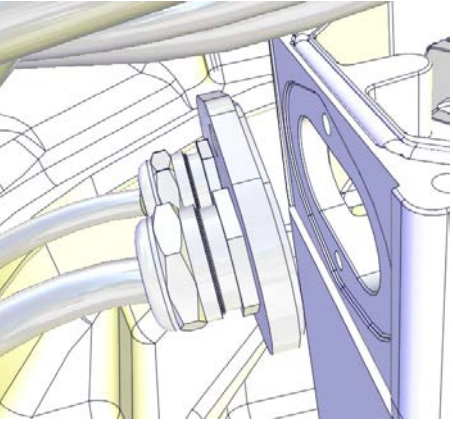

	Action	Note
1	<p>Push the motor cables in through the cable gland opening.</p>	 <p>xx1300000738</p>
2	<p>Refit the cable gland cover by performing the following steps:</p> <ul style="list-style-type: none"> • Slide the cable gland cover onto the inner screw. • Refit and tighten the outer screw. • Tighten the inner screw. Make sure that the gasket is not damaged. <p> Note</p> <p>Replace the gasket if damaged.</p>	 <p>xx1200001016</p>

Continues on next page

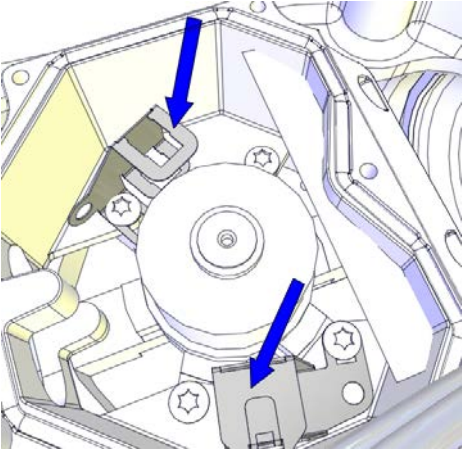
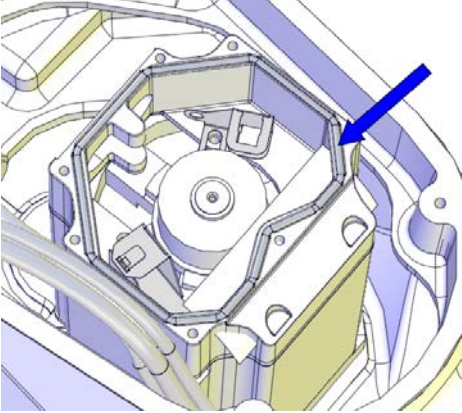

4 Repair

4.4.2 Refitting the cable harness

Continued

	Action	Note
3	Connect the connectors. Connect in accordance with the markings on the connectors.	 xx1200001015
4	Make sure the o-ring on the motor is undamaged. Replace if damaged.	O-ring, axis 5: 3HAC054692-001.  xx1200001021
5	 CAUTION When fitting the motor cover, make sure that none of the cables inside will be damaged.	

Continues on next page

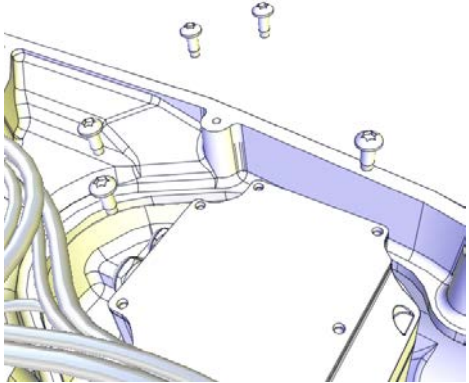
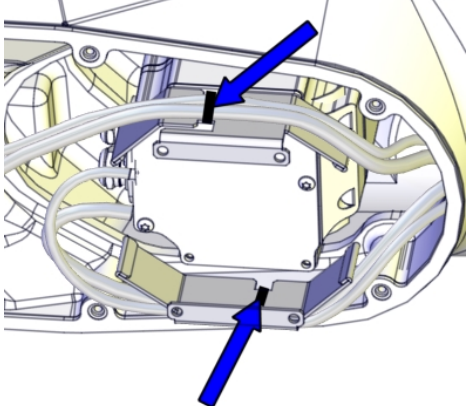
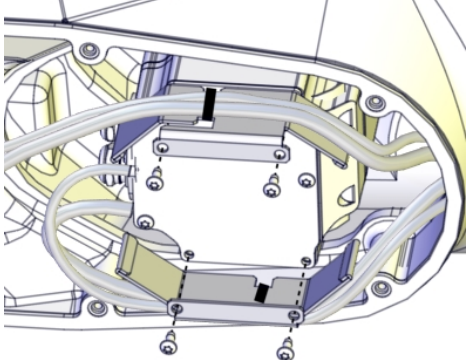
	Action	Note
6	<p>Refit the motor cover with its attachment screws.</p> <p> Note</p> <p>Do not refit the screws that will hold the heat protection plate at this point.</p> <p> Note</p> <p>Do not reuse the self-threading attachment screws, it will damage the threads. Replace with standard attachment screws.</p> <p> Note</p> <p>Make sure the o-ring is undamaged and properly fitted.</p>	<p>Screws: M5x12.</p>  <p>xx1200001013</p>
7	<p>Secure the cable harness with cable straps to the heat protection plate.</p>	 <p>xx1500001029</p>
8	<p>Fit the heat protection plate with the screws.</p>	<p>Screws: M5x12.</p>  <p>xx1500001030</p>



Continues on next page

4 Repair



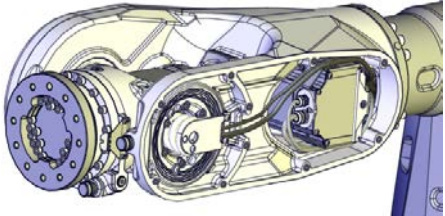

4.4.2 Refitting the cable harness

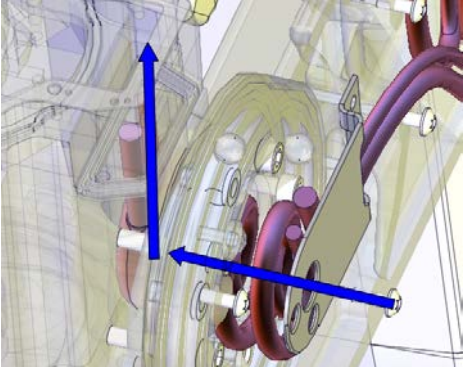
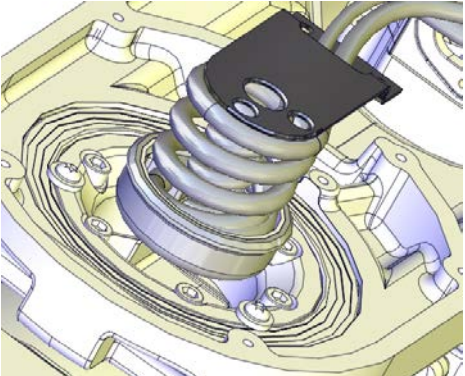
Continued

Connecting the axis-6 motor cables

	Action	Note
1	Make sure that the cable harness is placed in a way that it will not be damaged when the cover is fitted.	 xx1600002061
2	 Note Axis 5 must be in position +90° (or as close as possible) for a correct installation of the cable harness in the wrist. If not, connect the 24 VDC power supply, release the brakes and move axis 5 manually to +90°.	Position +90° of axis 5 makes the turning disc face the floor, if the robot is floor standing.
3	Push the cable harness into the wrist recess and up into the axis-6 motor.	 xx1300000667
4	Push the carrier carefully into position.	 xx1300001113

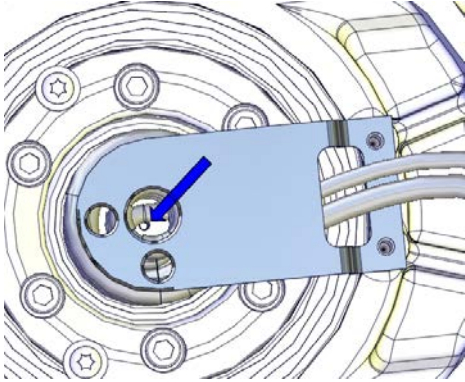
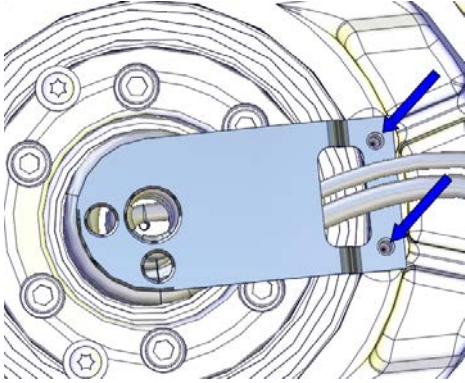
Continues on next page

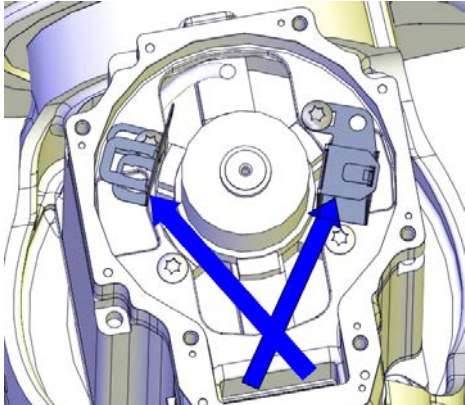

	Action	Note
5	<p>Secure the carrier with the M4 screw.</p> <p> Note</p> <p>The screw is located at the bottom of the carrier.</p> <p> Tip</p> <p>The attachment screw securing the carrier may be difficult to fit. Make sure the carrier is level and completely pressed against the bottom.</p>	 <p>xx1300000485</p>
6	<p>Secure the cable bracket with its attachment screws.</p>	 <p>xx1300000484</p>
7	<p>Reconnect the connectors to the axis-6 motor.</p> <p> Note</p> <p>Place the resolver cable under the motor cable.</p>	 <p>xx1300000488</p>

Continues on next page

4 Repair

4.4.2 Refitting the cable harness

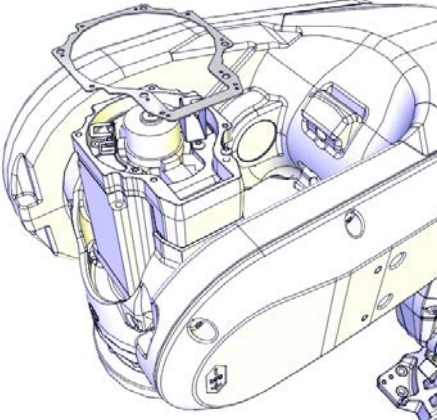

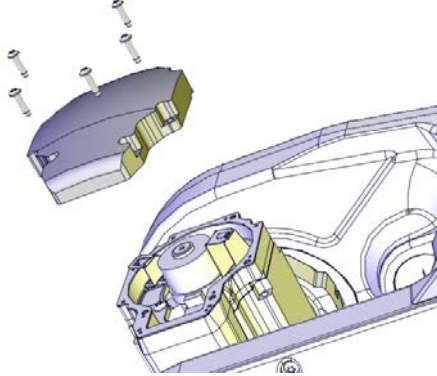
Continued

	Action	Note
8	<p>Make sure the gasket is undamaged. Replace if damaged.</p>	<p>Gasket, 3HAC033489-001</p>  <p>xx1200001095</p>
9	<p> CAUTION</p> <p>When fitting the motor cover, make sure that none of the cables inside will be damaged.</p>	
10	<p>Refit the motor cover.</p>	 <p>xx1200001080</p>

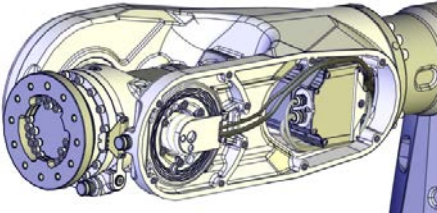
Concluding procedure

	Action	Note
1	<p>Make sure that the cable harness is placed in a way that it will not be damaged when the wrist cover is fitted.</p>	 <p>xx1600002061</p>

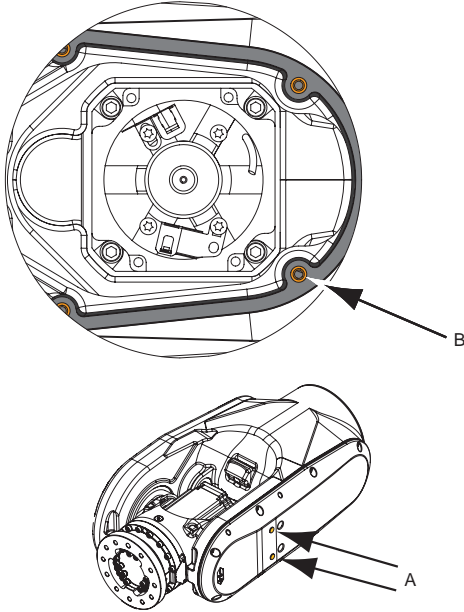
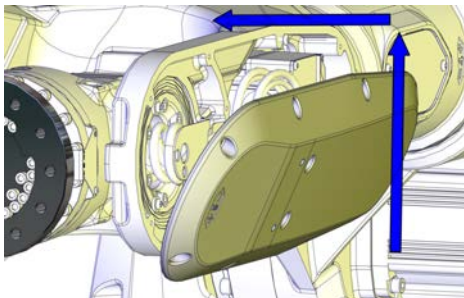
Continues on next page

	Action	Note
2	<p>Foundry Plus: Inspect the gasket. Replace if damaged. Put washers in the holes of the gasket.</p>	 <p>xx140000383</p> <p>A Protection plugs (2 on wrist cover and 2 on cover axis-5 gearbox) B Washers (10 pcs) in gasket holes</p>
3	<p>Refit the wrist cover. In order not to damage the cable harness when the wrist cover is refitted, use this method:</p> <ol style="list-style-type: none"> 1 Hold the cover slightly tilted below the wrist. 2 Put the cable harness inside the cover. 3 Lift the cover, still tilted. 4 Move the upper part of the cover into position. 5 Secure the cover with its attachment screws. 	 <p>xx130000772</p> <p>Tightening torque: 10 Nm.</p>
4	<p>Foundry Plus: Refit protection plugs.</p>	See figure above!
5	If used, refit the DressPack cable package on the wrist.	
6	Make an overall inspection of the installed cable harness.	See Inspecting the cable harness on page 129 .
7	Re-calibrate the robot.	<p>Axis Calibration is described in Calibrating with Axis Calibration method on page 694. General calibration information is included in section Calibration on page 683.</p>
8	<p> DANGER</p> <p>Make sure all safety requirements are met when performing the first test run. See Test run after installation, maintenance, or repair on page 97.</p>	

4 Repair

4.4.3 Replacing the SMB

4.4.3 Replacing the SMB

Location of SMB unit

The SMB (serial measurement board) unit is located inside the SMB/BU recess, as shown in the figure.

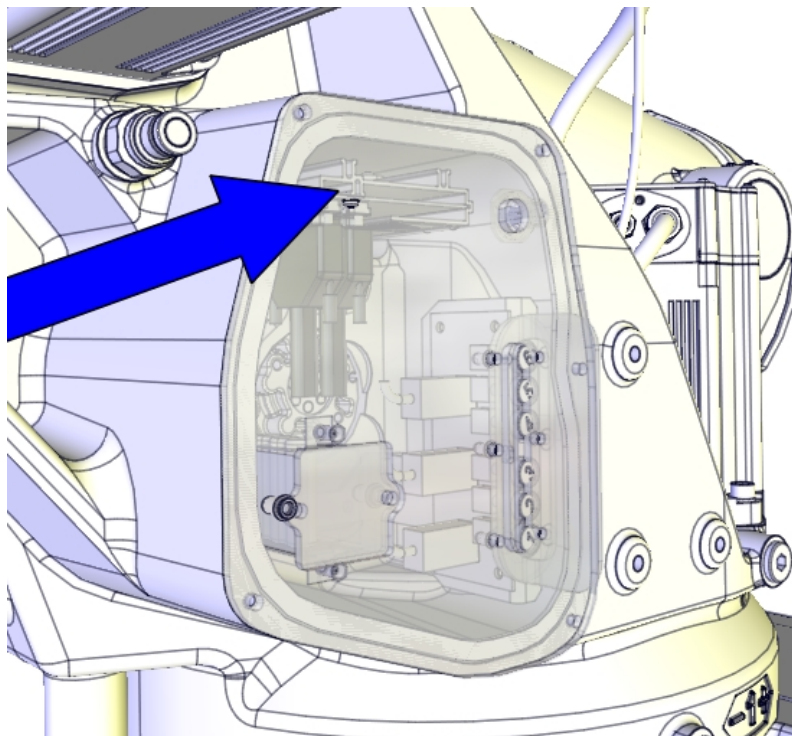

xx1300000740

Spare part

Equipment, etc.	Article number	Note
SMB unit (DSQC633C)	See <i>Product manual, spare parts - IRB 6700/IRB 6700Inv</i>	
Battery pack	See <i>Product manual, spare parts - IRB 6700/IRB 6700Inv</i>	

Required tools and equipment





Equipment, etc.	Article number	Note
Standard toolkit	-	Content is defined in section Standard toolkit on page 724 .

Continues on next page

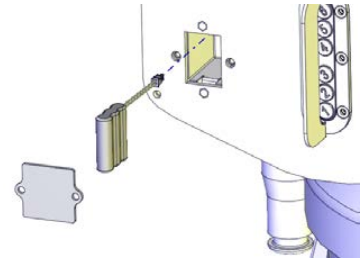

Removing the SMB unit

Use these procedures to disconnect and remove the SMB unit.

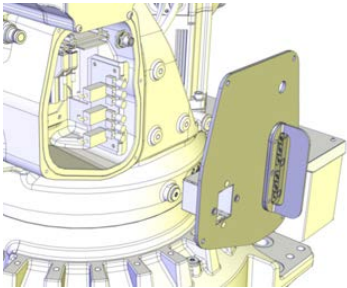
Preparations before disconnecting the SMB unit

	Action	Note
1	 DANGER Make sure that all supplies for electrical power, hydraulic pressure, and air pressure are turned off.	
2	 ELECTROSTATIC DISCHARGE (ESD) The unit is sensitive to ESD. Before handling the unit please read the safety information in the section <i>The unit is sensitive to ESD on page 54</i>	
3	Open the small cover on the SMB cover, disconnect the battery cable and remove the battery.	 xx1300000829
4	Remove the SMB cover.  CAUTION Clean cover from metal residues before opening. Metal residues can cause shortage on the boards which can result in hazardous failures.	 xx1300000669

Disconnecting and removing the SMB unit

	Action	Note
1	 DANGER Make sure that all supplies for electrical power, hydraulic pressure, and air pressure are turned off.	
2	 ELECTROSTATIC DISCHARGE (ESD) The unit is sensitive to ESD. Before handling the unit please read the safety information in the section <i>The unit is sensitive to ESD on page 54</i>	

Continues on next page

4 Repair

4.4.3 Replacing the SMB

Continued

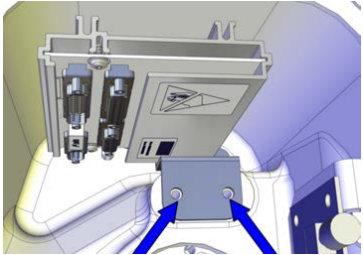
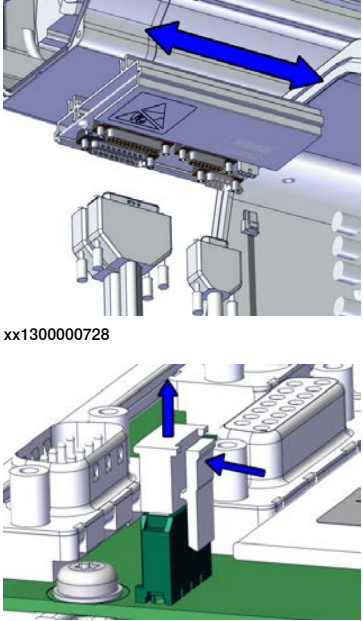
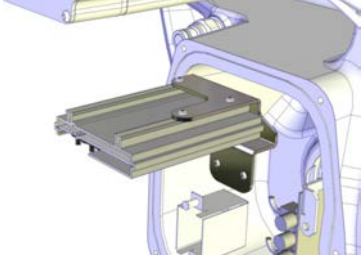
	Action	Note
3	Remove the screws and washers that secure the SMB unit bracket.	 <p>xx130000730</p>
4	Pull out the SMB unit a little and disconnect the connectors from the SMB board: <ul style="list-style-type: none"> • R1.SMB1-3, R1.SMB4-6 and R2.SMB • Battery cable connector R2.G. Disconnect the battery cable by pressing down the upper lip of the R2.G connector to release the lock while pulling the connector upwards.	 <p>xx130000728</p> <p>xx170000993</p>
5	Pull out the SMB unit and put it in an ESD bag.	 <p>xx130000731</p>

Refitting the SMB unit

Refitting the SMB unit

	Action	Note
1	 <p>DANGER</p> <p>Make sure that all supplies for electrical power, hydraulic pressure, and air pressure are turned off.</p>	

Continues on next page

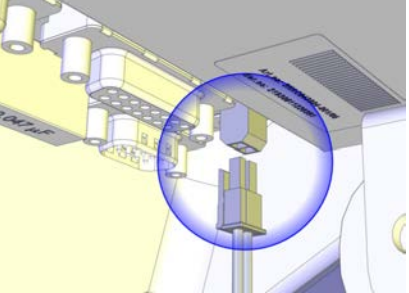
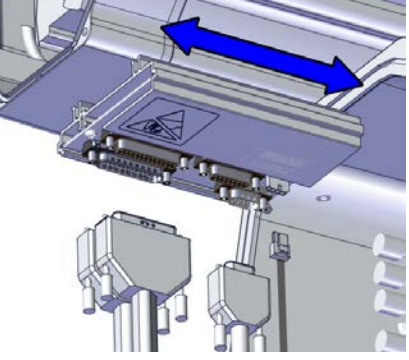
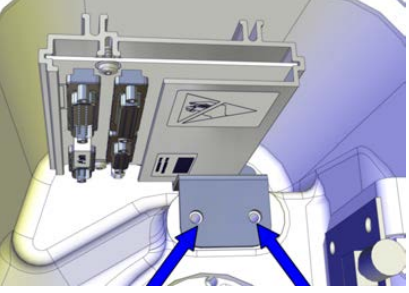
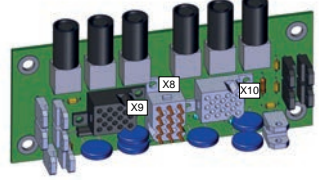
	Action	Note
2	 <p>ELECTROSTATIC DISCHARGE (ESD)</p> <p>The unit is sensitive to ESD. Before handling the unit please read the safety information in the section The unit is sensitive to ESD on page 54</p>	
3	<p>Connect the battery cable to the SMB unit. Make sure the lock snaps into place during refitting.</p>	 <p>xx1300000729</p>
4	<p>Connect all connectors to the SMB board:</p> <ul style="list-style-type: none"> • R1.SMB1-3, R1.SMB4-6 and R2.SMB 	 <p>xx1300000728</p>
5	<p>Push the SMB unit carefully into position and fit the bracket that secures the SMB unit.</p>	 <p>xx1300000730</p>
6	<p>If disconnected, reconnect the connectors X8, X9 and X10 to the brake release board. Be careful not to damage the sockets or pins. Make sure the connector and its locking arms are snapped down properly.</p>	 <p>xx1700000978</p>

Continues on next page

4 Repair

4.4.3 Replacing the SMB

Continued

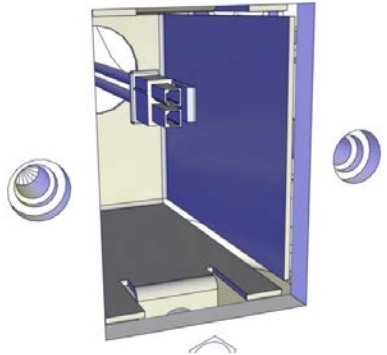
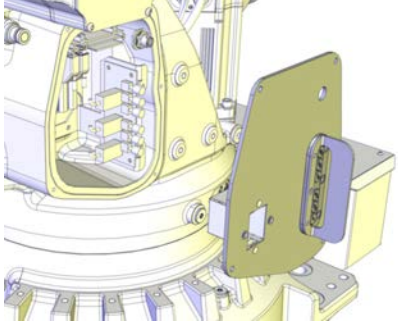
	Action	Note
7	Pull out the battery cable through the recess for the battery.	 <p>xx1300000834</p>
8	Secure the SMB cover with the attachment screws. If cabling is used for 7th axis (option), refit the connector R2.FB7 to the SMB cover and tighten with 6 Nm.	 <p>xx1300000669</p>

Refitting the SMB battery

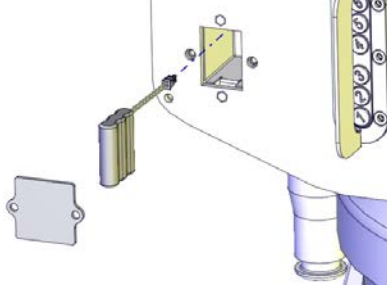
	Action	Note
1	 ELECTROSTATIC DISCHARGE (ESD) The unit is sensitive to ESD. Before handling the unit please read the safety information in the section The unit is sensitive to ESD on page 54	
2	Reconnect the battery cable.	
3	Place the battery in the recess.	 <p>xx1300000829</p>
4	Refit the battery cover with its attachment screws.	

Continues on next page

Concluding procedures

	Action	Note
1	Update the revolution counters.	See Updating revolution counters on IRC5 robots on page 690 .
2	 DANGER Make sure all safety requirements are met when performing the first test run. See Test run after installation, maintenance, or repair on page 97 .	

4 Repair

4.4.4 Replacing the brake release unit

4.4.4 Replacing the brake release unit

Location of brake release unit

The brake release unit (BU) is located inside SMB/BU recess, as shown in the figure.

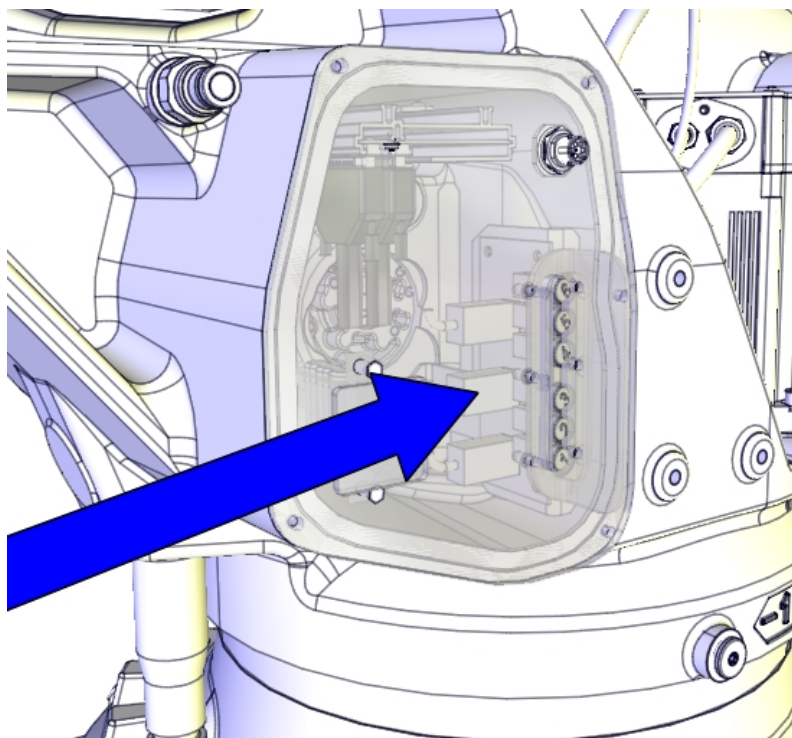

xx1300000741

Spare part

Equipment, etc.	Article number	Note
Brake release unit	See <i>Product manual, spare parts - IRB 6700/IRB 6700Inv</i>	
Battery pack	See <i>Product manual, spare parts - IRB 6700/IRB 6700Inv</i>	





Required tools and equipment

Equipment, etc.	Article number	Note
Standard toolkit	-	Content is defined in section Standard toolkit on page 724 .

Continues on next page

Removing the brake release unit

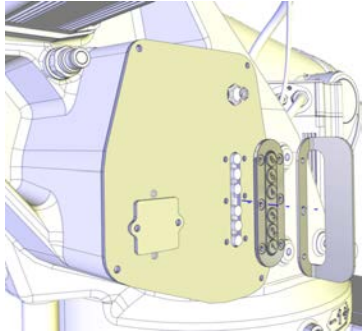
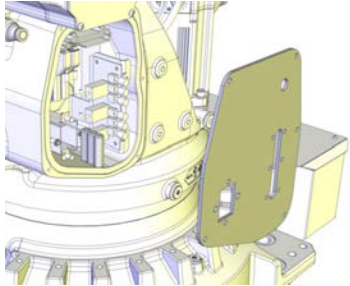
Preparations before removing the brake release unit

	Action	Note
1	 DANGER Turn off all: <ul style="list-style-type: none"> • electric power supply • hydraulic pressure supply • air pressure supply to the robot, before entering the safeguarded space.	
2	 ELECTROSTATIC DISCHARGE (ESD) The unit is sensitive to ESD. Before handling the unit please read the safety information in the section The unit is sensitive to ESD on page 54	
3	Remove the push button guard from the SMB cover. The push button guard must be removed to ensure a correct refitting of the brake release unit.	 xx1300000743
4	Remove the SMB cover.	 xx1300000742
5	The battery can stay connected, to avoid the need of synchronizing the robot.  CAUTION If the battery stays connected, put (or hold) the SMB cover in a safe position. The battery cable connectors can otherwise be damaged.	



Continues on next page

4 Repair

4.4.4 Replacing the brake release unit

Continued

Disconnecting the brake release unit

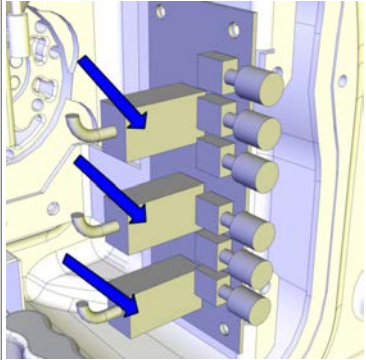
	Action	Note
1	 DANGER Make sure that all supplies for electrical power, hydraulic pressure, and air pressure are turned off.	
2	 ELECTROSTATIC DISCHARGE (ESD) The unit is sensitive to ESD. Before handling the unit please read the safety information in the section <i>The unit is sensitive to ESD on page 54</i>	
3	Take a picture or make notes of how the robot cabling is positioned in regard to the brake release board.	
4	Remove the connectors X8, X9 and X10 from the brake release board.	 xx130000670

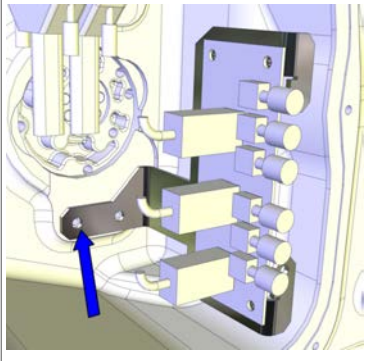

Removing the brake release unit

	Action	Note
1	Unscrew the attachment screws that secure the brake release unit bracket.	 xx130000744
2	Remove the bracket with the brake release unit fitted.	
3	Remove the brake release unit from the bracket.	

Continues on next page

Refitting the brake release unit

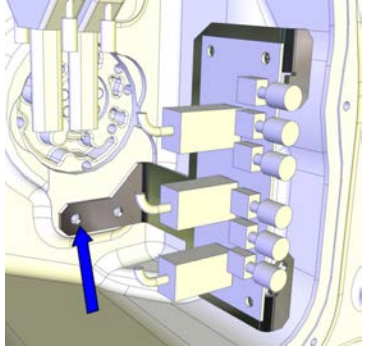
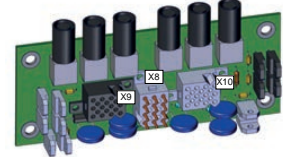
Use this procedure to refit the brake release unit.

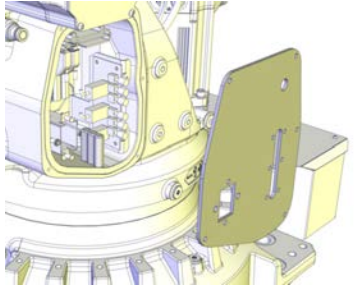

	Action	Note
1	 <p>ELECTROSTATIC DISCHARGE (ESD)</p> <p>The unit is sensitive to ESD. Before handling the unit please read the safety information in the section <i>The unit is sensitive to ESD on page 54</i></p>	
2	<p>Fasten the brake release unit to the bracket.</p>	<p>Maximum tightening torque: 5 Nm.</p>
3	<p>Refit the bracket with the brake release unit fitted. Make sure the unit is placed as straight as possible on the bracket! The push buttons can otherwise get jammed when the SMB cover is refitted.</p>	 <p>xx130000744</p>
4	<p>Reconnect the connectors X8, X9 and X10 to the brake release unit. Be careful not to damage the sockets or pins. Make sure the connector and its locking arms are snapped down properly.</p>	 <p>xx170000978</p>
5	<p>Verify that the robot cabling is positioned correctly, according to previously taken picture/notes.</p>  <p>WARNING</p> <p>Screened cables must not get in contact with the brake release board after installation. Eliminate all risks of contact between screened cables and the brake release board.</p>	
6	<p>Refit the SMB cover with its attachment screws.</p>  <p>Note</p> <p>Do not refit the push button guard at this point!</p>	 <p>xx130000742</p>

Continues on next page

4 Repair

4.4.4 Replacing the brake release unit

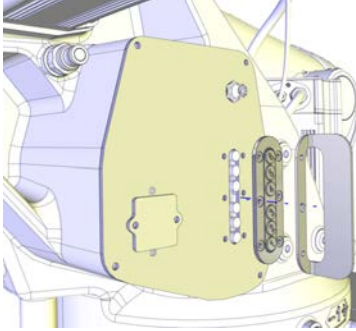
Continued

	Action	Note
7	 WARNING Before continuing any service work, follow the safety procedure in section The brake release buttons may be jammed after service work on page 198!	
8	Refit the push button guard to the SMB cover.	 xx130000743
9	Press the push buttons 1 to 6, one at a time, to make sure that the buttons are moving freely and do not stay in any locked position.	
10	Reconnect the battery, if it has been disconnected.	
11	Update the revolution counters if the battery has been disconnected.	See Updating revolution counters on IRC5 robots on page 690.
12	 DANGER Make sure all safety requirements are met when performing the first test run. See Test run after installation, maintenance, or repair on page 97.	

4.5 Upper and lower arms

4.5.1 Replacing the upper arm

Location of the upper arm

The upper arm is located as shown in the figure. These sections describe how to replace the complete upper arm, which includes the wrist unit.

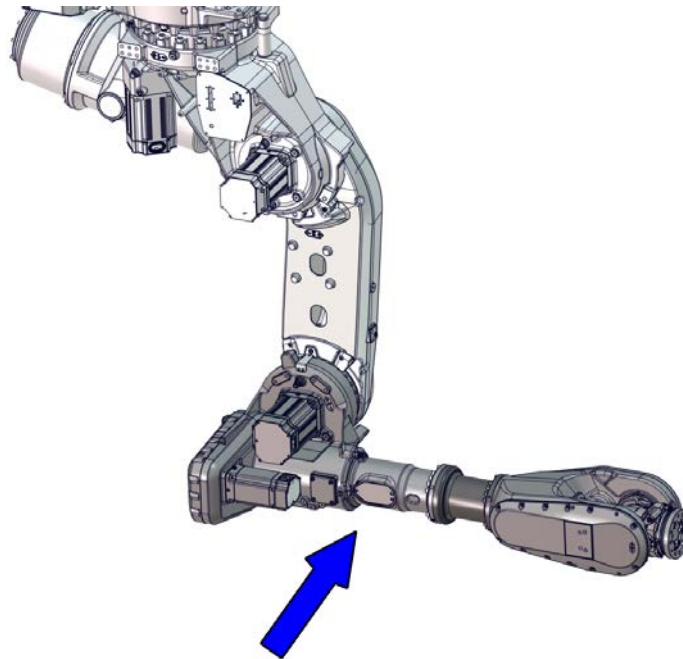

xx1600002096

Spare part

Spare part	Spare part number	Note
Upper arm	See <i>Product manual, spare parts - IRB 6700/IRB 6700Inv</i>	

Consumables

Parts needed to be replaced after removal.

Equipment, etc.	Article number	Note
Grease	3HAC042536-001	Shell Gadus S2 Used to lubricate o-rings.
O-ring	3HAC054692-002	D=169.5x3 Used on axis-3 motor cover.
	3HAC054692-001	D=119x3 Used on axis-4 motor cover.
	3HAC054692-001	D=119x3 Used on axis-5 motor cover.
Gasket	3HAC033489-001	Used on axis-6 motor cover.

Continues on next page

4 Repair

4.5.1 Replacing the upper arm

Continued

Equipment, etc.	Article number	Note
Rust preventive	3HAC034903-001	Mercasol 3110 Waxcoat. Recommended drying time is 24h. Used on Foundry Plus.

Required tools and equipment

Equipment, etc.	Article number	Note
Lifting eye, M12	3HAC16131-1	
Lifting eye, M12	3HAC16131-1	
Fender washer	-	Outer diameter: minimum 26 mm, maximum 30 mm, hole diameter: 13 mm, thickness: 3 mm.
Roundsling, 2 m	-	Lifting capacity: 2,000 kg.
Roundsling, 2 m	-	Lifting capacity: 2,000 kg.
Pallet		Used for putting down removed parts from robot.
Guide pin, M16x150	3HAC13120-2	Always use guide pins in pairs.
Guide pin, M16x200	3HAC13120-3	Always use guide pins in pairs.
24 VDC power supply	-	Used to release the motor brakes.
Rotation tool	3HAB7887-1	Used to rotate the motor pinion.
Calibration tool box, Axis Calibration	3HAC055412-001	Delivered as a set of calibration tools.
Standard toolkit	-	Content is defined in section Standard toolkit on page 724 .

Required documents

Document	Document number
Directions for use - Fork lift accessory 3HAC058825-001	3HAC060303-001
Directions for use - Lifting and rotating accessory for IRB 6700Inv/IRB6700I	3HAC073537-003

Deciding calibration routine

Decide which calibration routine to be used, based on the information in the table. Depending on which routine is chosen, action might be required prior to beginning the repair work of the robot, see the table.

	Action	Note
1	Decide which calibration routine to use for calibrating the robot. <ul style="list-style-type: none">Reference calibration. External cable packages (DressPack) and tools can stay fitted on the robot.Fine calibration. All external cable packages (DressPack) and tools must be removed from the robot.	

Continues on next page

Action	Note
<p>If the robot is to be calibrated with reference calibration: Find previous reference values for the axis or create new reference values. These values are to be used after the repair procedure is completed, for calibration of the robot. If no previous reference values exist, and no new reference values can be created, then reference calibration is not possible.</p>	<p>Follow the instructions given in the reference calibration routine on the FlexPendant to create reference values. Creating new values requires possibility to move the robot. Read more about reference calibration for Axis Calibration in Reference calibration routine on page 695.</p>
<p>If the robot is to be calibrated with fine calibration: Remove all external cable packages (DressPack) and tools from the robot.</p>	

Removing the upper arm

Use these procedures to remove the upper arm.

Preparations before removing the upper arm

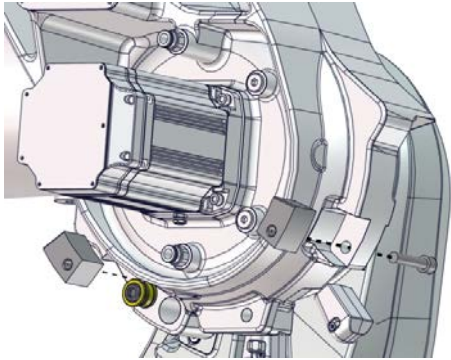
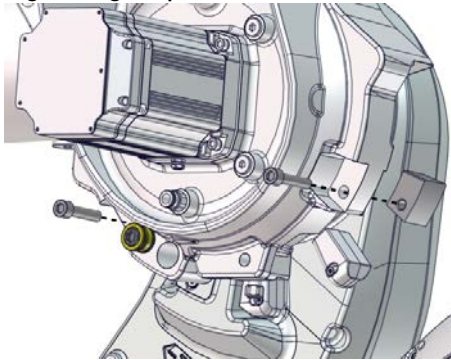

Action	Note
1	Decide which calibration routine to use, and take actions accordingly prior to beginning the repair procedure.
2	Remove the service stops from their parking position.  <p>xx170000448</p>
3	Fit the service stops in maintenance position.  <p>xx170000449</p> <p>Tightening torque: 70 Nm ±15 Nm.</p>

Continues on next page

4 Repair

4.5.1 Replacing the upper arm

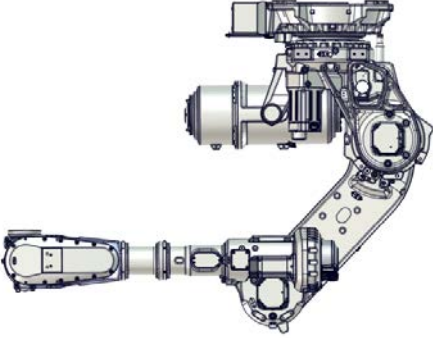
Continued

	Action	Note
4	<p>Jog the robot to the position:</p> <ul style="list-style-type: none"> • Axis-1: a position that allows best possible access to fit the lifting accessories to the upper arm. • Axis-2: -35 • Axis-3: -143 (so that the upper arm is horizontal) • Axis-4: 0° • Axis-5: -90° • Axis-6: 0° 	 <p>xx1700000450</p>
5	<p> DANGER</p> <p>Turn off all:</p> <ul style="list-style-type: none"> • electric power supply • hydraulic pressure supply • air pressure supply <p>to the robot, before entering the safe-guarded space.</p>	
6	<p>Remove tools and other equipment fitted to wrist and upper arm.</p>	
7	<p>Prepare an area where to put the upper arm, after removal. On pallets, as a suggestion.</p>	

Retrieving access to the wrist cabling

Use this procedure to remove the wrist cover to retrieve access to the axis-5 and axis-6 motor cables.

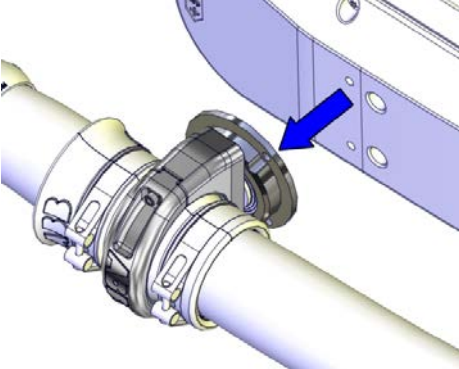
	Action	Note
1	<p> DANGER</p> <p>Make sure that all supplies for electrical power, hydraulic pressure, and air pressure are turned off.</p>	
2	<p>If DressPack is installed:</p> <ul style="list-style-type: none"> • Remove the bracket with the complete ball joint housing still fitted, as shown in the figure. <p>This is done to be able to reach the two hidden screws that secure the wrist cover.</p>	 <p>xx1400000355</p>

Continues on next page

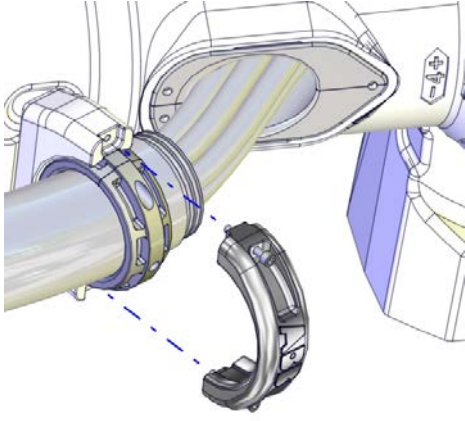
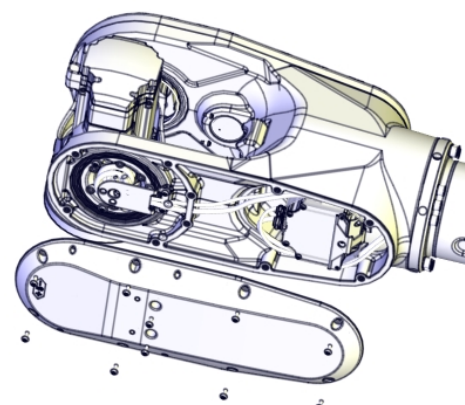
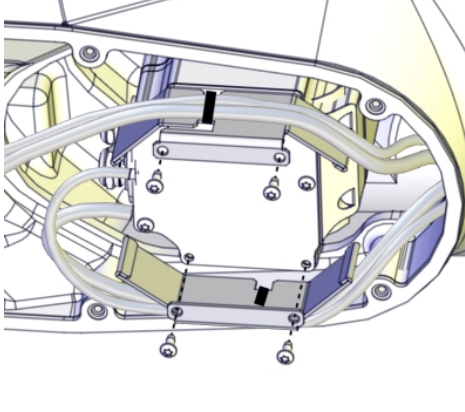

	Action	Note
3	If used, open the ball joint housing on the arm tube and remove the DressPack cable package.	 <p>xx140000206</p>
4	Remove the wrist cover.	 <p>xx1300002247</p>
5	Remove the heat protection plates from the motor with the cabling still attached to the plate.	 <p>xx1500001030</p>

Continues on next page

4 Repair

4.5.1 Replacing the upper arm

Continued

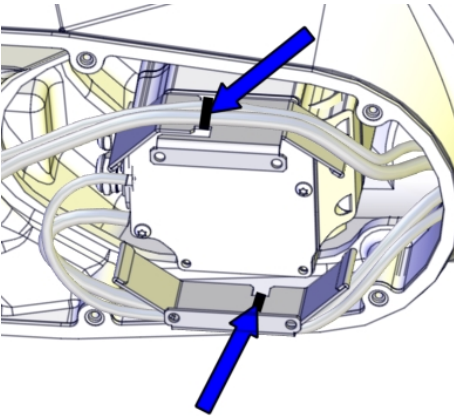
	Action	Note
6	<p>Cut the cable ties that hold the cable harness to the plate.</p> <p> Note</p> <p>Keep the heat protection plate until refitting.</p> <p> Tip</p> <p>If removing the plate only for replacing the motor, the cabling does not need to be loosened from the plate.</p>	 <p>xx1500001029</p>



Removing the DressPack cable package

Remove the DressPack cable package from the upper arm, if used. How to remove the DressPack cable package is described in more detail in the product manual "IRB 6700 DressPack". For article number see [References on page 10](#).

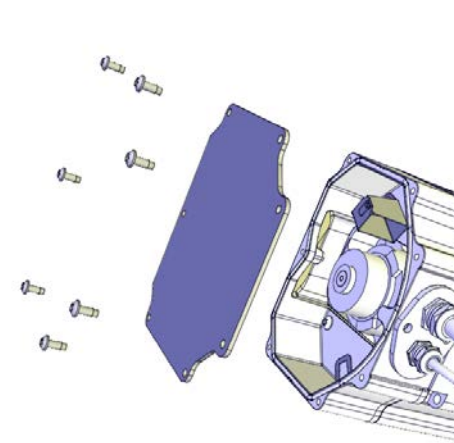
Disconnecting the axis-5 motor cables

	Action	Note
1	<p> DANGER</p> <p>Make sure that all supplies for electrical power, hydraulic pressure, and air pressure are turned off.</p>	
2	<p>Unscrew the attachment screws and washers and remove the motor cover.</p>	 <p>xx1200001135</p>

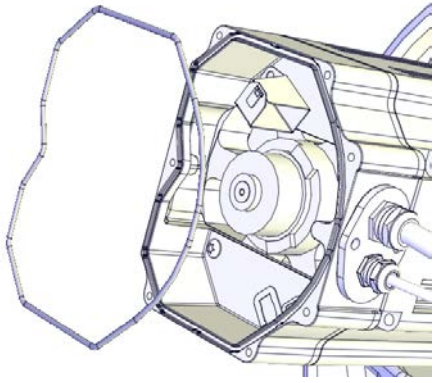
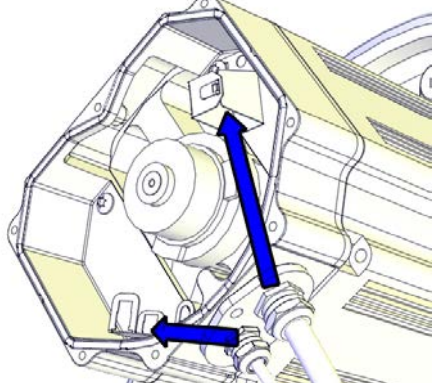
Continues on next page

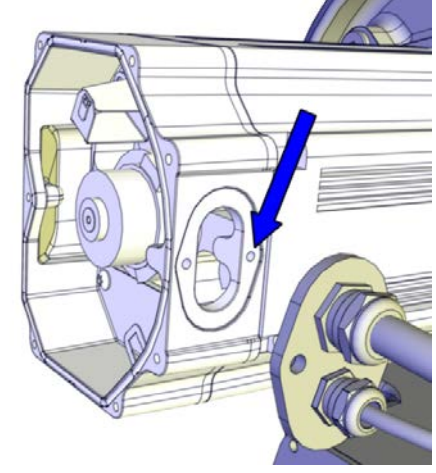
	Action	Note
3	Make sure the o-ring is present.	 <p>xx1200001070</p>
4	Disconnect the motor cables.	 <p>xx1200001066</p>
5	<p>Remove the cable gland cover by performing the following steps:</p> <ol style="list-style-type: none"> 1 Open the inner screw a little (the one the arrow is pointing at). No need to remove this screw from the motor. 2 Remove the outer screw. 3 Slide the cable gland cover away from the inner screw. Make sure the gasket is not damaged. <p> Tip</p> <p>Make a note in which direction the cable exit hole is facing, if the motor will be removed too. The motor shall be refitted in the same position.</p>	 <p>xx1300000656</p>
6	Use caution and pull out the motor cables.	

Continues on next page

4 Repair

4.5.1 Replacing the upper arm

Continued

Disconnecting the axis-6 motor cables

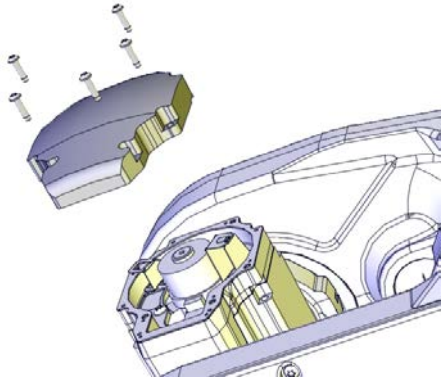
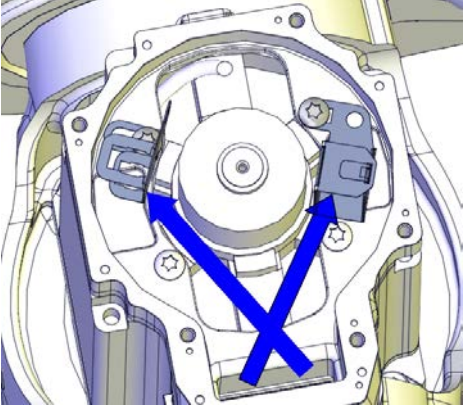
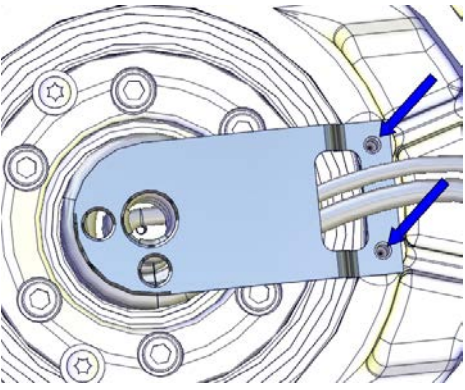
	Action	Note
1	 DANGER Make sure that all supplies for electrical power, hydraulic pressure, and air pressure are turned off.	
2	Unscrew the attachment screws and remove the motor cover.	 xx1200001080
3	Disconnect the motor cables.	 xx1300000488
4	Unscrew the attachment screws that hold the cable bracket.	 xx1300000484

Continues on next page

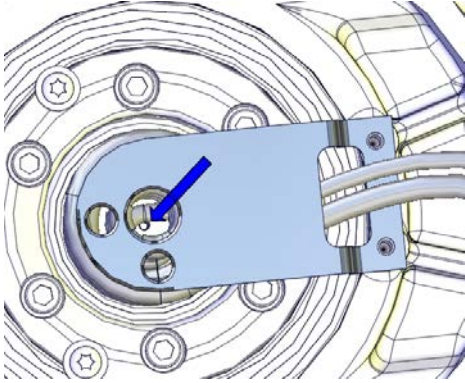
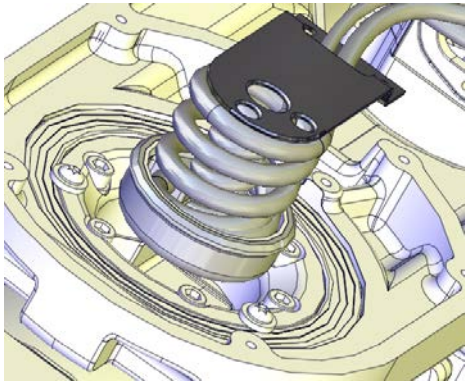
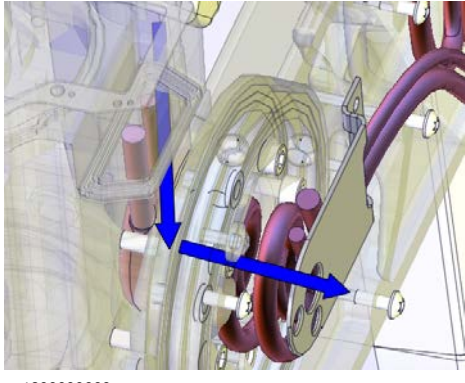
	Action	Note
5	<p>Unscrew the M4 screw that holds the carrier.</p> <p> Note</p> <p>The screw is located at the bottom of the carrier.</p>	 <p>xx130000485</p>
6	<p>Pull out the carrier from its position.</p>	 <p>xx1300001113</p>
7	<p>Pull out the axis-6 motor cables by holding the cables with one hand at the motor and the other at the carrier.</p>	 <p>xx130000666</p>

Disconnecting the axis-3 and axis-4 motor cables

	Action	Note
1	<p> DANGER</p> <p>Make sure that all supplies for electrical power, hydraulic pressure, and air pressure are turned off.</p>	

Continues on next page

4 Repair

4.5.1 Replacing the upper arm

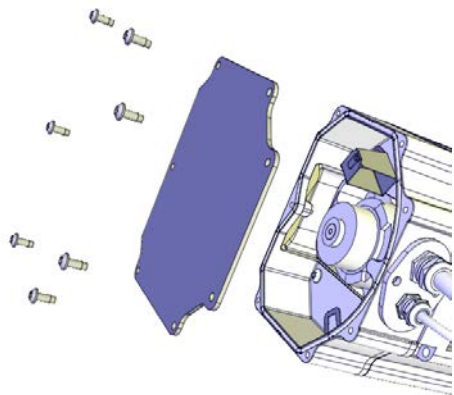
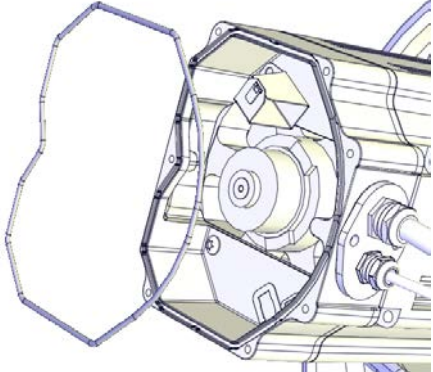
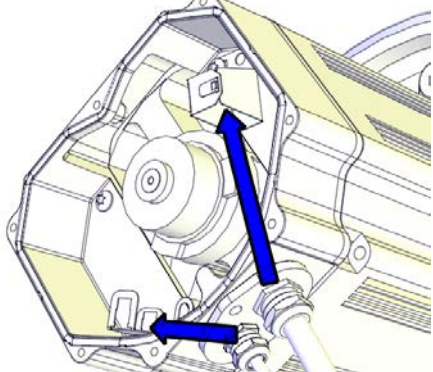

Continued

	Action	Note
2	Unscrew the attachment screws and washers and remove the motor cover.	 <p>xx1200001135</p>
3	Make sure the o-ring is present.	 <p>xx1200001070</p>
4	Disconnect the motor cables.	 <p>xx1200001066</p>

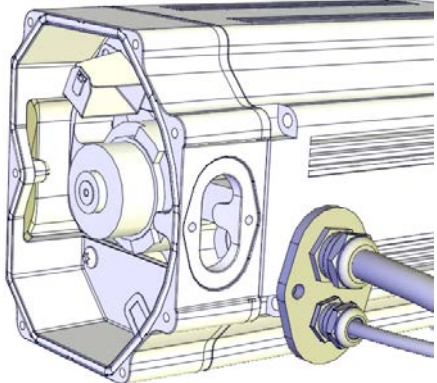
Continues on next page

	Action	Note
5	<p>Remove the cable gland cover. Make sure the gasket is not damaged.</p> <p> Tip</p> <p>Make a note in which direction the cable gland hole is facing, if the motor will be removed too. The motor shall be refitted in the same position.</p>	 <p>xx1200001067</p>
6	Use caution and pull out the motor cables.	

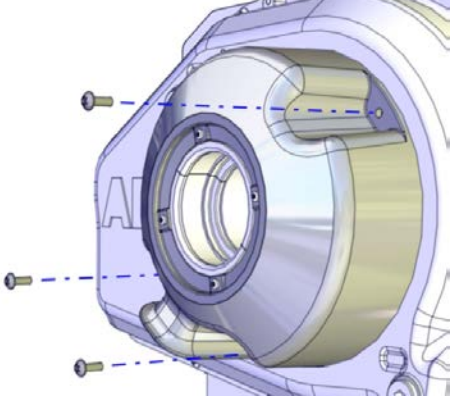
Removing the cable harness - wrist and upper arm



	Action	Note
1	<p>Remove the cover.</p> <p> Note</p> <p><i>Foundry Plus:</i> Use caution not to damage the gasket, not to loose the washers on the cover sealing or not to loose the inserts fitted on the cover.</p>	 <p>xx120000045</p>
2	If the cabling is to be replaced by a new cable harness, remove the cover insert to use it on the new cabling.	 <p>xx1700001803</p>

Continues on next page

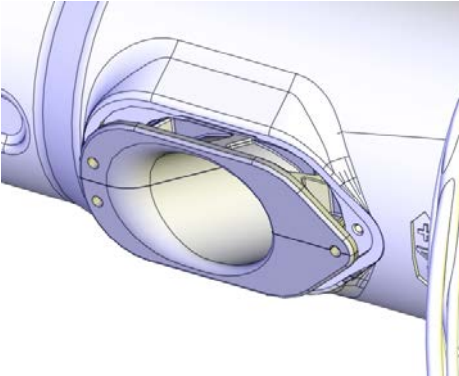
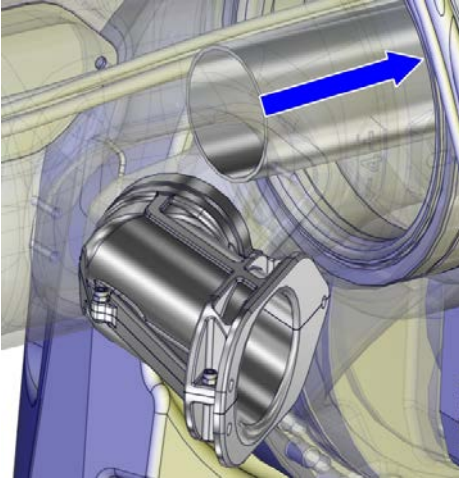

4 Repair

4.5.1 Replacing the upper arm

Continued

	Action	Note
3	If used, loosen the insert.	 xx170000690
4	If used, push the DressPack tube a little backwards.	 xx140000720
5	 Tip Use tape and tie the axis-5 and axis-6 connectors and carrier into a bundle (if not already done). This is done to facilitate the removal and to avoid damaging the parts. This will also make it easier to run the cable harness through the inside of the upper arm.	 xx130000668

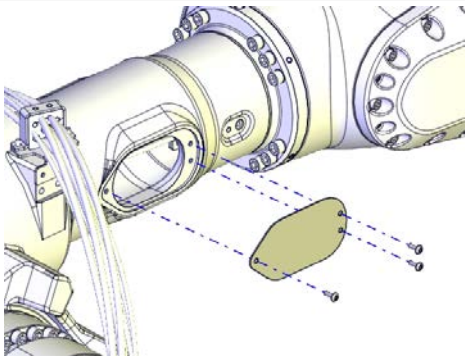
Continues on next page

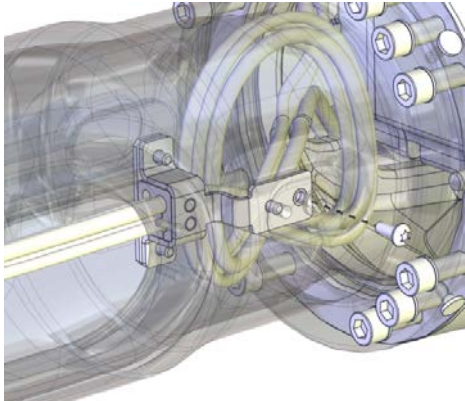
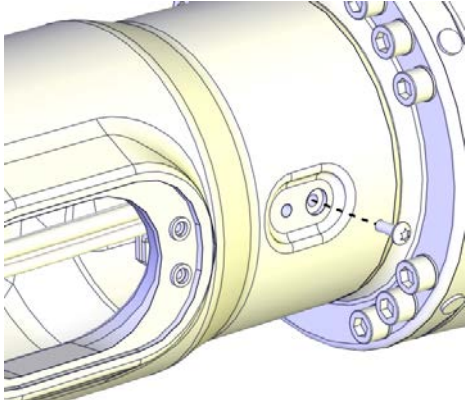
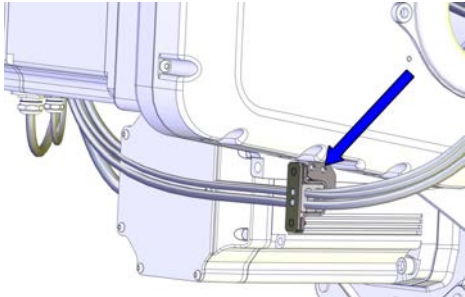
	Action	Note
6	Remove the side cover on the arm tube.	 <p>xx130000557</p>
7	Unscrew the attachment screw that secures the axis-4 metal clamp inside the arm tube.  Note The screw is reached from outside the upper arm.	 <p>xx170000340</p>  <p>xx170000339</p>
8	Remove the arm house metal clamp.	 <p>xx130000543</p>

Continues on next page



4 Repair

4.5.1 Replacing the upper arm

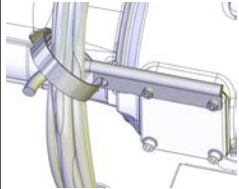
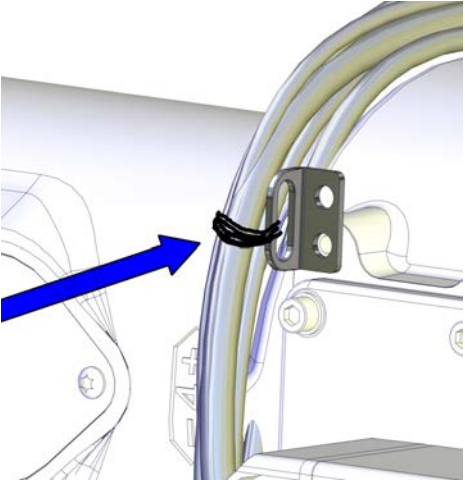
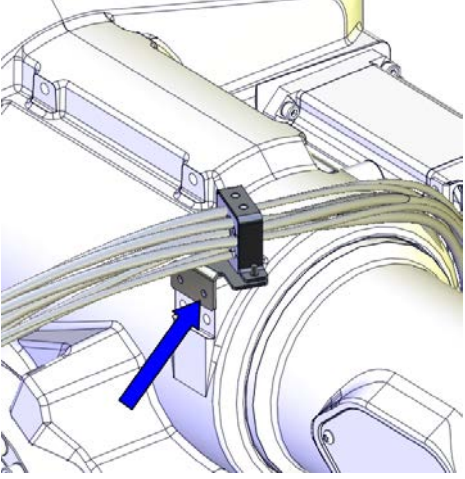
Continued

	Action	Note
9	<p>Cut the cable tie at the cable fixing bracket.</p> <p> Note</p> <p>If DressPack is fitted, the cable fixing bracket is replaced by the cable guide.</p>  <p>xx1300001973</p> <p>Cable guide.</p>	 <p>xx1300000544</p> <p>Cable fixing bracket.</p>
10	<p>Remove the metal clamp on top of the arm house.</p>	 <p>xx1300000541</p>

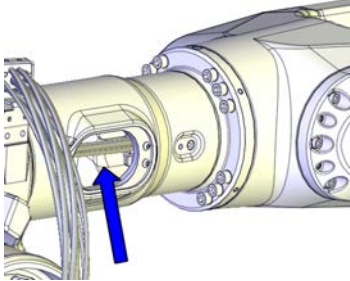
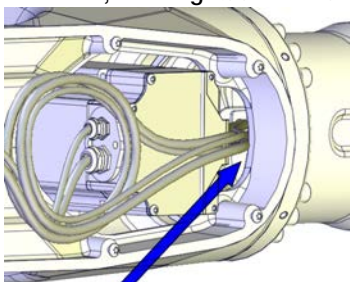
Continues on next page

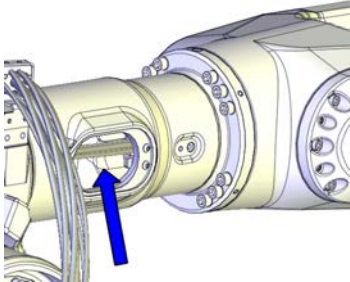
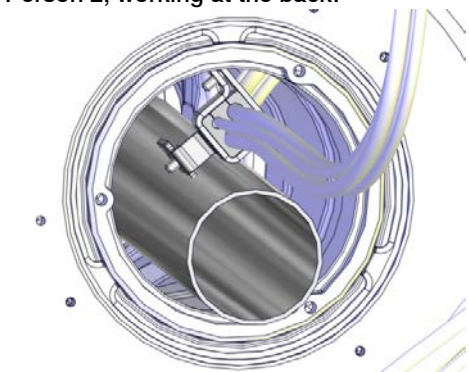
	Action	Note
11	<p>Remove the cable harness out from the wrist.</p> <p> Tip</p> <p>This step is best performed by two persons working together:</p> <ul style="list-style-type: none"> • Person 1: Put one hand inside the side hole and take a hold of the cable harness. • Person 2: Take a hold on the cable harness inside the wrist. • Together: Move the cable harness past the axis-5 motor and into the arm tube. 	<p>Person 1, working at the side hole:</p>  <p>xx130000745</p> <p>Person 2, working at the wrist:</p>  <p>xx130000746</p>
12	<p>Remove the cable harness out of the arm tube, at the back of the upper arm.</p> <p> Tip</p> <p>This step is best performed by two persons working together:</p> <ul style="list-style-type: none"> • Person 1: Put one hand inside the side hole and take a hold of the cable harness. • Person 2: Take a hold on the cable harness at the back of the robot. • Together: Move the cable harness out of the arm tube. 	<p>Person 1, working at side hole:</p>  <p>xx130000745</p> <p>Person 2, working at the back:</p>  <p>xx140002561</p>

Continues on next page





4 Repair

4.5.1 Replacing the upper arm

Continued

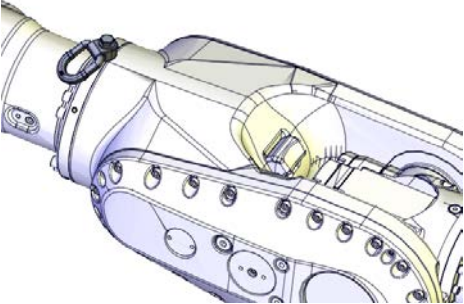
Attaching the lifting accessories

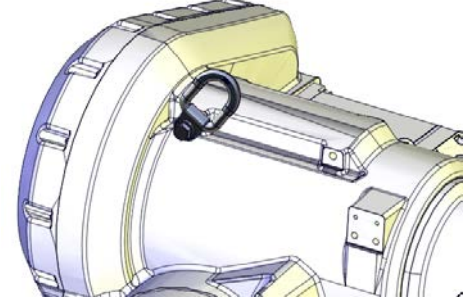

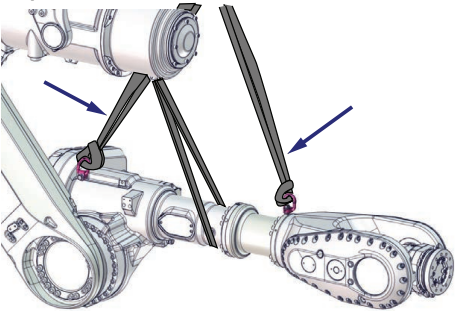
Use this procedure to attach the lifting accessories to the upper arm.

	Action	Note
1	 CAUTION The weight of the complete upper arm (including the wrist) is 465 kg All lifting accessories used must be sized accordingly.	
2	Fit a lifting eye to the wrist.	Lifting eye, M12: 3HAC16131-1  xx1200001133
3	Fit a lifting eye in the arm house, with a fender washer underneath.  xx1400002196	Lifting eye, M12: 3HAC16131-1 Fender washer: Outer diameter: minimum 26 mm, maximum 30 mm, hole diameter: 13 mm, thickness: 3 mm.  xx1200001134
4	Attach a lifting sling to an overhead crane (or similar) and then to the lifting eye in the arm house.	Roundsling, 2 m: Lifting capacity: 2,000 kg. (2 pcs)
5	Attach a lifting sling to an overhead crane (or similar) and then to the lifting eye in the wrist.  Note Lifting slings are used instead of lifting chains to not damage the balancing device surface.	 xx1700000693
6	Raise the lifting accessories to take the weight of the upper arm.	

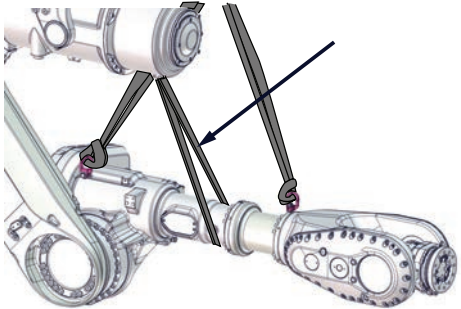
Continues on next page

	Action	Note
7	Remove the lifting sling between the upper arm and the balancing device.	 <p>xx180000047</p>

Preparations before removing the upper arm

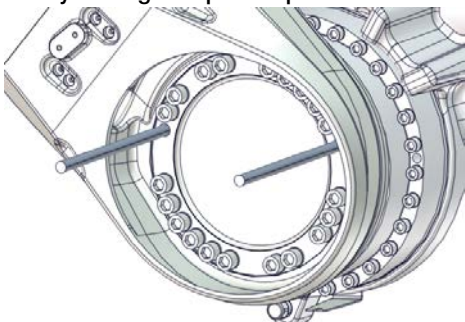
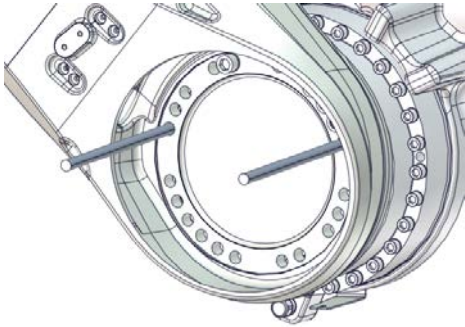
	Action	Note
1	<p>Remove two attachment screws in opposite holes and replace them with guide pins.</p> <p> Note</p> <p>Make sure that it is the screws that hold the lower arm to the axis-3 gearbox that are removed!</p> <p> Tip</p> <p>Lubricate the guide pins with some grease to make the upper arm slide better.</p>	<p>Guide pin, M16x150: 3HAC13120-2 Guide pin, M16x200: 3HAC13120-3 Always use guide pins in pairs.</p>  <p>xx1700000457</p>
2	<p>Leave one of the remaining attachment screws fitted, remove the other screws.</p>	 <p>xx1700000458</p>

Continues on next page

4 Repair

4.5.1 Replacing the upper arm

Continued

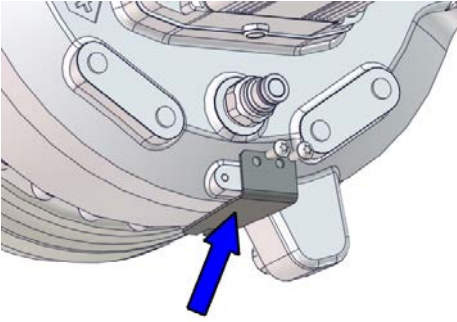
	Action	Note
3	Remove the axis-3 synchronization mark plate.	 xx170000694

Removing the upper arm

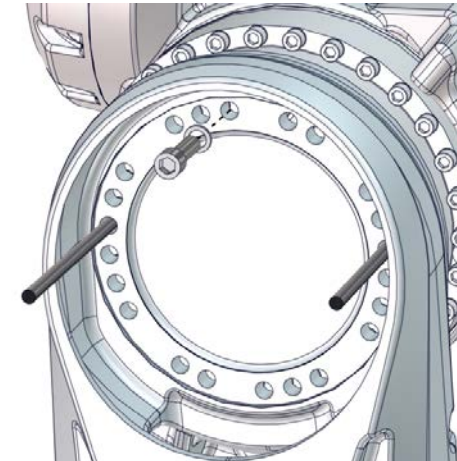
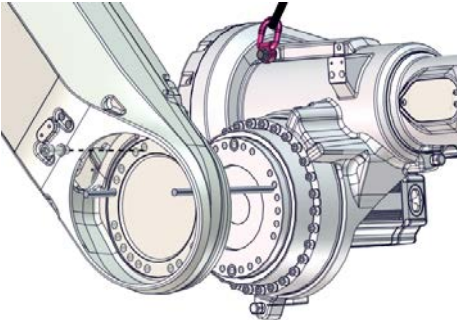
	Action	Note
1	Remove the remaining attachment screw and let the upper arm slide out from the lower arm with support from the guide pins.	 xx170000059  xx170000459
2	Lift the upper arm and place it on the prepared area.	

Continues on next page

4.5.1 Replacing the upper arm
Continued

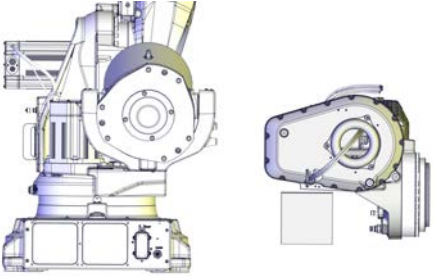
	Action	Note
3	<p><i>This step is only valid when the upper arm is removed due to replacement of the axis-3 gearbox:</i></p> <p>Place pieces of wood (or similar) under arm house and wrist. Lower the upper arm, and let the upper arm rest as shown in the figure.</p> <p>This is done in order to keep the axis-3 gearbox in a vertical position and to get the best position to replace the axis-3 gearbox, if applicable.</p>	 <p>xx1300000553</p>

Refitting the upper arm

Use these procedures to refit the upper arm.

Preparations before refitting the upper arm

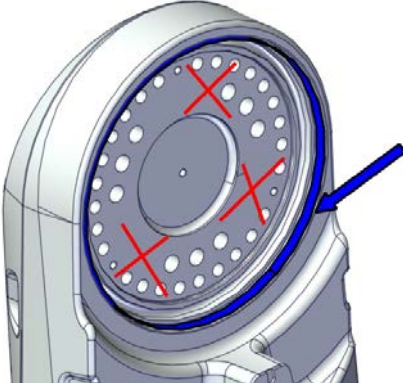
	Action	Note
1	Wipe clean all contact surfaces.	
2	<p><i>Foundry Plus:</i></p> <p>Apply Mercasol on the surface on the lower arm as shown in the figure.</p> <p> CAUTION</p> <p>Keep the sealing surfaces clean from Mercasol.</p>	<p>Rust preventive: 3HAC034903-001 (Mercasol 3110 Waxcoat. Recommended drying time is 24h.)</p>  <p>xx1700001880</p>

Continues on next page

4 Repair

4.5.1 Replacing the upper arm

Continued

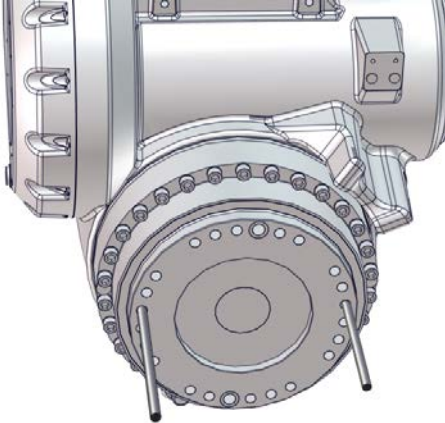
	Action	Note
3	<p>Fit two guide pins in opposite M16 holes in the axis-3 gearbox.</p> <p> Tip</p> <p>Lubricate the guide pins with some grease to make the upper arm slide better.</p>	<p>Guide pin, M16x150: 3HAC13120-2 Guide pin, M16x200: 3HAC13120-3 Always use guide pins in pairs.</p>  <p>xx170000056</p>

Securing the upper arm

	Action	Note
1	<p> CAUTION</p> <p>The weight of the complete upper arm (including the wrist) is 465 kg All lifting accessories used must be sized accordingly.</p>	
2	<p>Attach the lifting accessories, if not already fitted.</p>	<p>See Attaching lifting accessories to the upper arm on page 210.</p>
3	<p>Lift the upper arm and bring it towards the lower arm.</p>	
4	<p>If the axis-3 motor is installed to the upper arm: Connect the 24 VDC power supply, to release the brakes. Connect to R2.MP3-connector:</p> <ul style="list-style-type: none"> • + = pin 2 • - = pin 5 <p>Use the rotation tool and rotate the axis-3 motor to find the correct position for the guide pins in the lower arm. Disconnect and remove the 24 VDC power supply after finding the position.</p>	<p>24 VDC power supply Rotation tool</p>
5	<p>If the axis-3 motor is not installed to the upper arm: Use the pinion to rotate the axis-3 gearbox to find the correct position for the guide pins in the lower arm.</p>	<p>Pinion: 3HAC067545-001</p>

Continues on next page

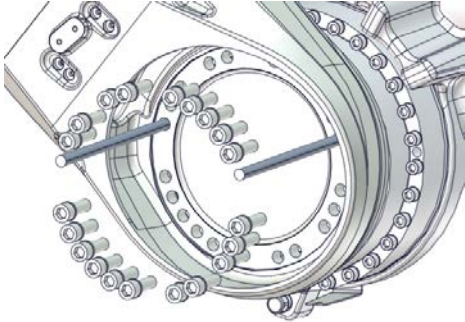
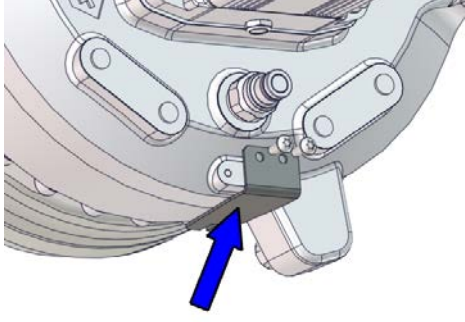
	Action	Note
6	Insert and tighten 20 of the 22 M16 screws.	 <p>xx170000460</p>
7	Remove the guide pins and fit the two remaining screws.	
8	Secure the upper arm by tightening the attachment screws.	M16, tightening torque: 300 Nm
9	Refit the axis-3 synchronization mark plate.	 <p>xx170000694</p>

Refitting the cable harness - upper arm

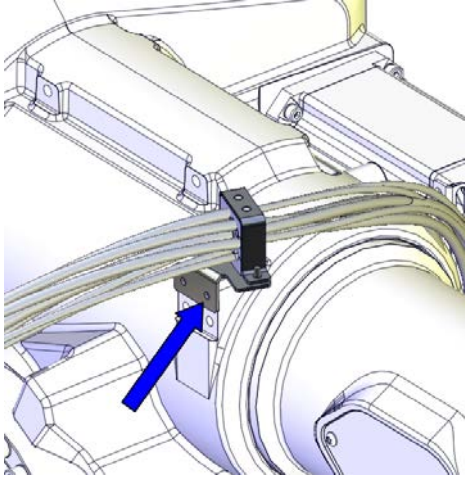

	Action	Note
1	Refit the metal clamp on top of the arm house.	 <p>xx130000541</p>

Continues on next page

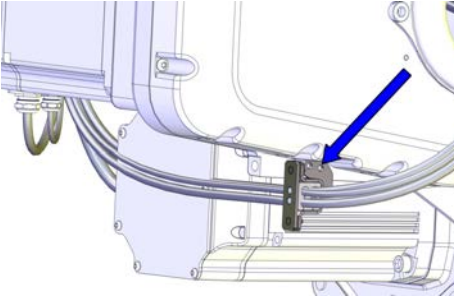

4 Repair

4.5.1 Replacing the upper arm

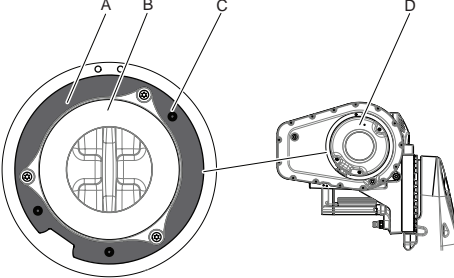
Continued

	Action	Note
2	Refit the arm house metal clamp.	 <p>xx130000543</p>
3	Arrange the cables between the cable clamps in the upper arm.	
4	 Tip Use tape and tie the axis-5 and axis-6 connectors and carrier into a bundle (if not already done). This is done to facilitate the procedure and to avoid damaging the parts during the procedure. This will also make it easier to run the cable harness through the inside of the robot.	 <p>xx130000668</p>
5	Foundry Plus: Make sure that the gasket underneath the cover is correctly fitted. Replace if damaged. The gasket is covered with adhesive on the side facing the upper arm cover. The three washers are pressed into the holes in the gasket. Make sure all three washers are fitted.	 <p>xx140000382</p> <p>A Gasket B Cable guide C Washer D Cover</p>

Continues on next page

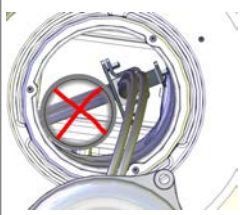
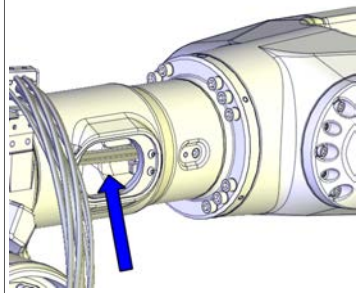
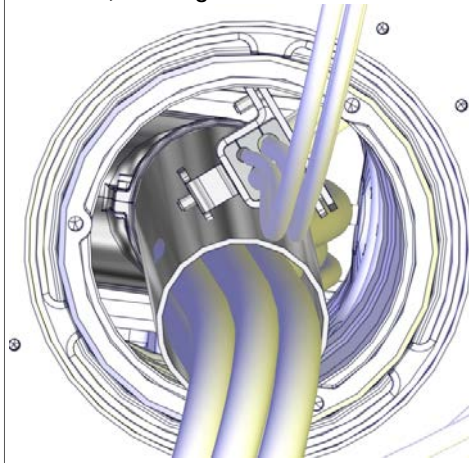

	Action	Note
6	<p>Run the cable harness through the cable guide and then into and through the upper arm tube.</p> <p> Tip</p> <p>This step is best performed by two persons working together:</p> <ul style="list-style-type: none"> • Person 1: Put one hand inside the side hole of the arm tube and take a hold of the cable harness. • Person 2: Take a hold on the cable harness at the back of the robot. • Together: Use caution and move the cable harness into the arm tube. <p> Note</p> <p>The cable harness is best placed at the upper right hand side of the DressPack tube, if used, through the arm tube.</p> <p>Do not run the cable harness into the DressPack tube!</p> <p> Note</p> <p>Do not run the cable harness into the DressPack tube, if one is fitted!</p> <p> xx130000820</p>	<p>Person 1, working at the side hole:</p> <p> xx130000745</p> <p>Person 2, working at the back:</p> <p> xx140000356</p>

Continues on next page

4 Repair

4.5.1 Replacing the upper arm

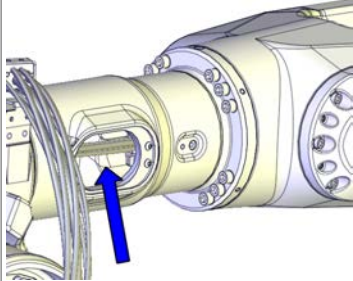
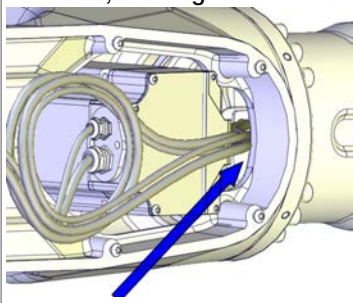
Continued

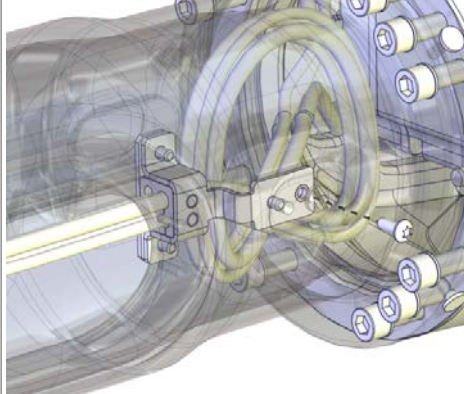
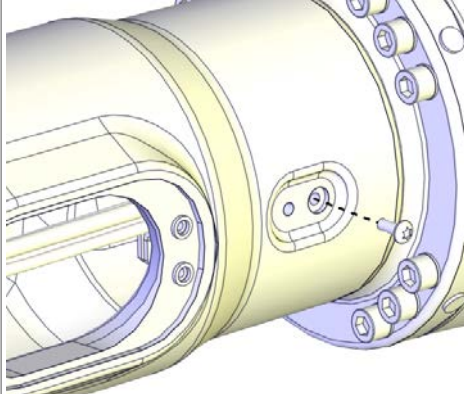
	Action	Note
7	<p>Use caution and push the cable harness into the wrist.</p> <p> Tip</p> <p>This step is best performed by two persons working together:</p> <ul style="list-style-type: none">• Person 1: Put one hand inside the side cover hole and take a hold of the cable harness.• Person 2: Take a hold of the cable harness from inside the wrist.• Together: Move the cable harness past the axis-5 motor and into the wrist.	<p>Person 1, working at the side hole:</p>  <p>xx130000745</p> <p>Person 2, working at the wrist:</p>  <p>xx130000746</p>
8	<p>Refit the metal clamp axis-4, inside the arm tube.</p> <p> Note</p> <p>The screws are reached from outside the upper arm.</p>	 <p>xx170000340</p>  <p>xx170000339</p>

Continues on next page

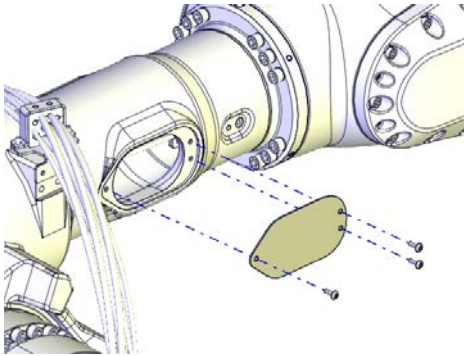
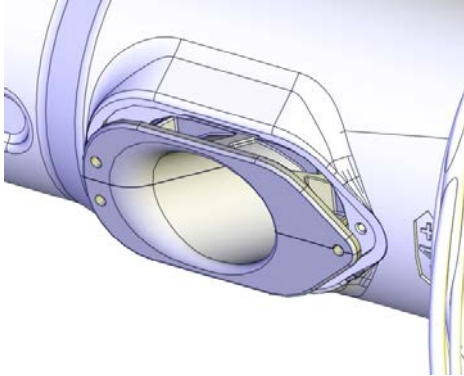
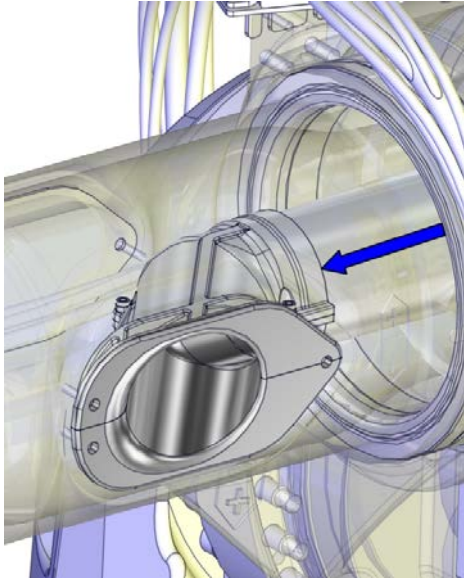
	Action	Note
9	<p>Refit the side cover.</p> <p> Note</p> <p><i>Foundry Plus:</i></p> <ul style="list-style-type: none"> • Make sure the gasket is fitted correctly on the side cover • Use attachment screws made of stainless steel to fit the side cover. 	 <p>xx130000557</p>
10	<p>If used, refit the insert that guides the DressPack cable package through the hole in the upper arm.</p>	 <p>xx170000690</p>
11	<p>If used, refit the tube containing the DressPack into the insert.</p>	 <p>xx140000092</p>

Continues on next page

4 Repair

4.5.1 Replacing the upper arm

Continued

	Action	Note
12	Fit the cover insert around the new cabling and secure it with a weatherstrip.	<p>Cover insert: 3HAC048520-001.</p>  <p>xx1700001803</p> <p>Weatherstrip: 3HAC053986-001.</p>  <p>xx1700001804</p>
13	<p><i>DressPack or Foundry Plus:</i> Refit the cover with the tube guiding ring fitted.</p> <p> Note</p> <p><i>Foundry Plus:</i></p> <ul style="list-style-type: none">• Make sure the gasket is fitted correctly• Use attachment screws made of stainless steel to fit the cover.	 <p>xx120000045</p>

Continues on next page

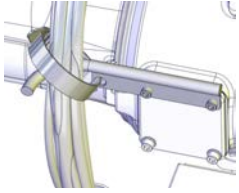
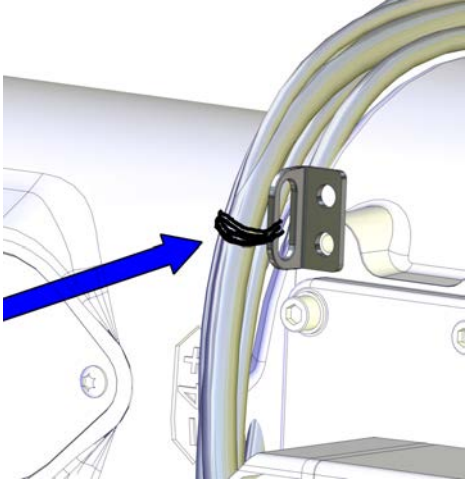
	Action	Note
14	<p>Secure the cable harness to the cable fixing bracket with a cable tie.</p> <p> Note</p> <p>If DressPack is fitted, the cable fixing bracket is replaced by the cable guide.</p>  <p>xx1300001973</p>	 <p>xx1300000544</p>

Refitting the DressPack cable package

If used, refit the DressPack cable package. How to refit the DressPack cable package is described in more detail in the product manual "IRB 6700 DressPack". For article number see [References on page 10](#).

Connecting the axis-3 and axis-4 motor cables

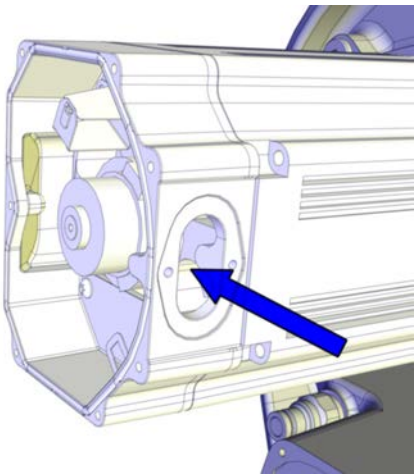

	Action	Note
1	<p>Push the motor cables through the cable gland opening.</p>	 <p>xx1300000738</p>

Continues on next page



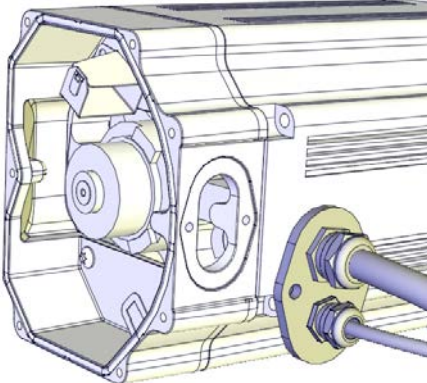
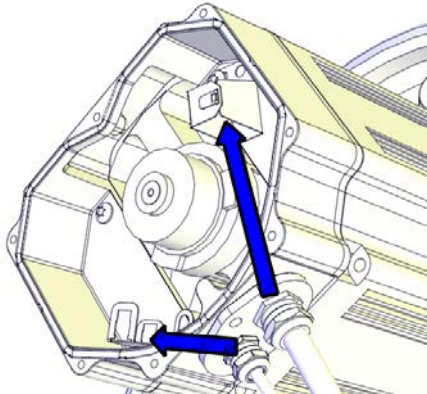

4 Repair

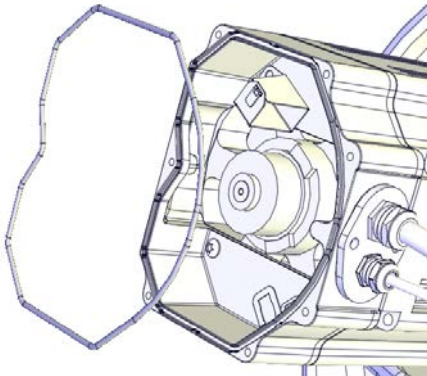
4.5.1 Replacing the upper arm

Continued

	Action	Note
2	Refit the cable gland cover.  Note Replace the gasket if damaged.	 xx1200001067
3	Connect the motor cables. Connect in accordance with the markings on the connectors.	 xx1200001066
4	Inspect the o-ring.  Note Replace if damaged.	O-ring, axis-1: 3HAC054692-002 O-ring, axis-2: 3HAC054692-002 O-ring, axis-3: 3HAC054692-002 O-ring, axis-4: 3HAC054692-001  xx1200001070
5	Wipe clean o-ring and o-ring groove.	

Continues on next page

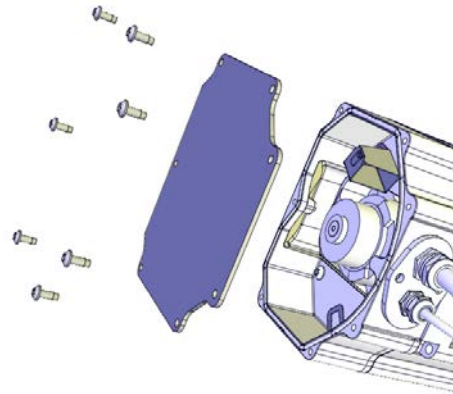
	Action	Note
6	Refit the o-ring.  Tip Lubricate the o-ring with some grease for a better fitting in the groove.	
7	 CAUTION When fitting the motor cover, make sure that none of the cables inside will be damaged.	
8	Refit the motor cover with it's attachment screws.  Note Do not reuse the self-threading attachment screws. Replace with standard attachment screws or the threads will be damaged.  Note Make sure the o-ring is undamaged and properly fitted.	Attachment screws: M5x12 8.8 (7 pcs)  xx1200001135
9	Make sure that the covers are tightly sealed.	

Connecting the axis-5 motor cables

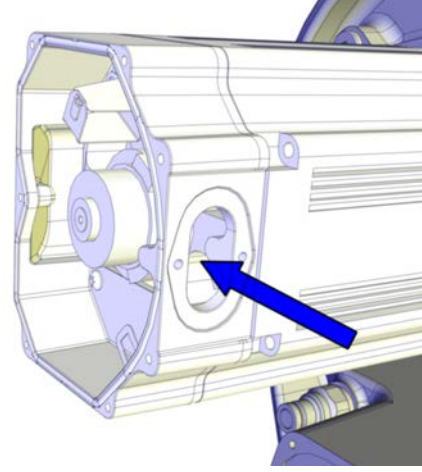

	Action	Note
1	Push the motor cables in through the cable gland opening.	 xx1300000738

Continues on next page

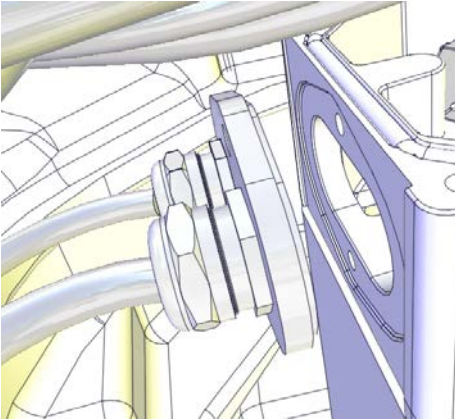
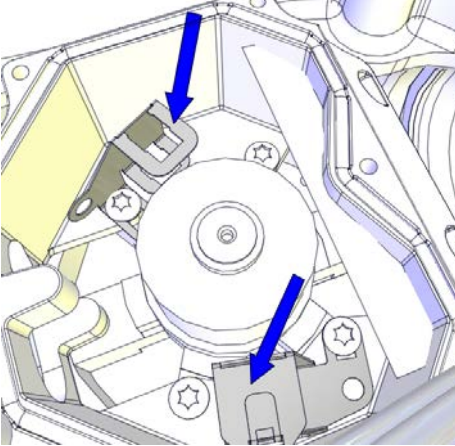
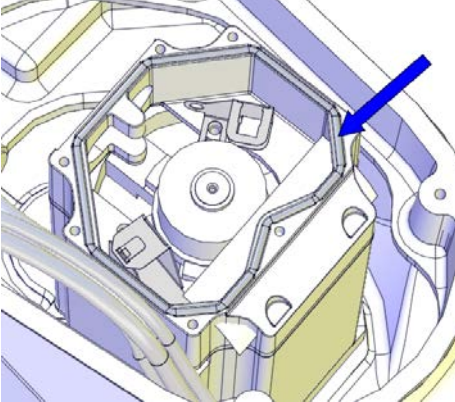

4 Repair

4.5.1 Replacing the upper arm

Continued

	Action	Note
2	<p>Refit the cable gland cover by performing the following steps:</p> <ul style="list-style-type: none">• Slide the cable gland cover onto the inner screw.• Refit and tighten the outer screw.• Tighten the inner screw. Make sure that the gasket is not damaged. <p> Note</p> <p>Replace the gasket if damaged.</p>	 <p>xx1200001016</p>
3	<p>Connect the connectors.</p> <p>Connect in accordance with the markings on the connectors.</p>	 <p>xx1200001015</p>
4	<p>Make sure the o-ring on the motor is undamaged.</p> <p>Replace if damaged.</p>	<p>O-ring, axis 5: 3HAC054692-001.</p>  <p>xx1200001021</p>
5	<p> CAUTION</p> <p>When fitting the motor cover, make sure that none of the cables inside will be damaged.</p>	

Continues on next page

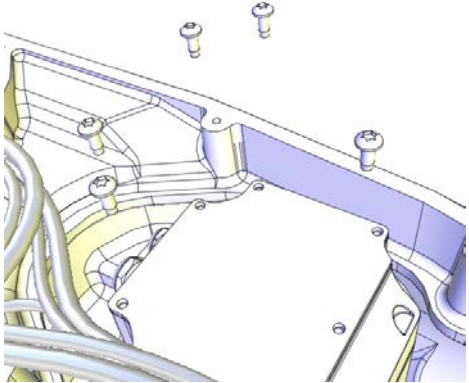
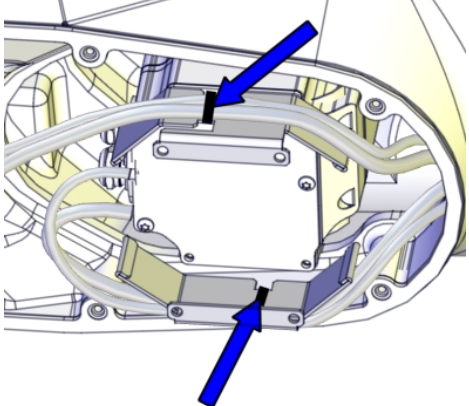
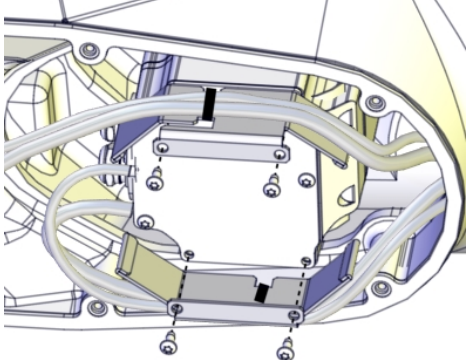
	Action	Note
6	<p>Refit the motor cover with its attachment screws.</p> <p> Note Do not refit the screws that will hold the heat protection plate at this point.</p> <p> Note Do not reuse the self-threading attachment screws, it will damage the threads. Replace with standard attachment screws.</p> <p> Note Make sure the o-ring is undamaged and properly fitted.</p>	<p>Screws: M5x12.</p>  <p>xx1200001013</p>
7	<p>Secure the cable harness with cable straps to the heat protection plate.</p>	 <p>xx1500001029</p>
8	<p>Fit the heat protection plate with the screws.</p>	<p>Screws: M5x12.</p>  <p>xx1500001030</p>



Continues on next page

4 Repair



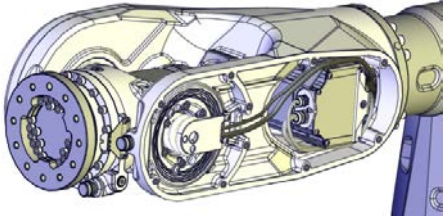

4.5.1 Replacing the upper arm

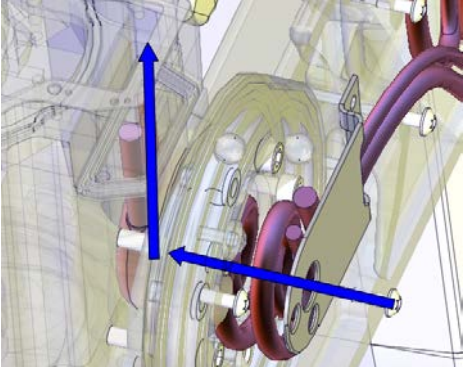
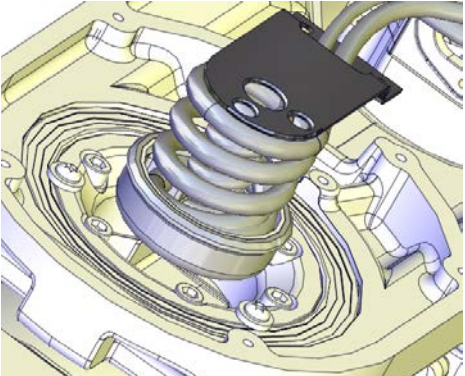
Continued

Connecting the axis-6 motor cables

	Action	Note
1	Make sure that the cable harness is placed in a way that it will not be damaged when the cover is fitted.	 xx1600002061
2	 Note Axis 5 must be in position +90° (or as close as possible) for a correct installation of the cable harness in the wrist. If not, connect the 24 VDC power supply, release the brakes and move axis 5 manually to +90°.	Position +90° of axis 5 makes the turning disc face the floor, if the robot is floor standing.
3	Push the cable harness into the wrist recess and up into the axis-6 motor.	 xx1300000667
4	Push the carrier carefully into position.	 xx1300001113

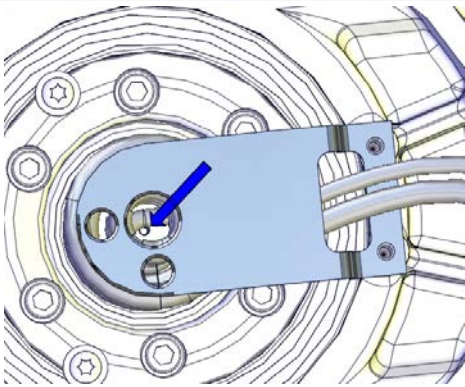
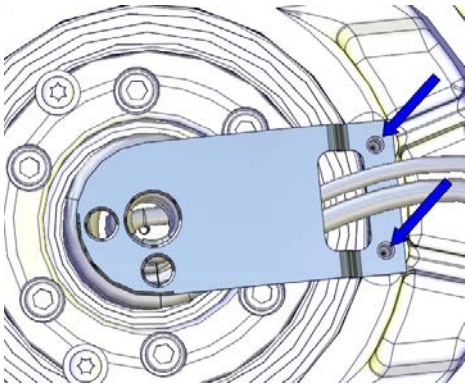
Continues on next page

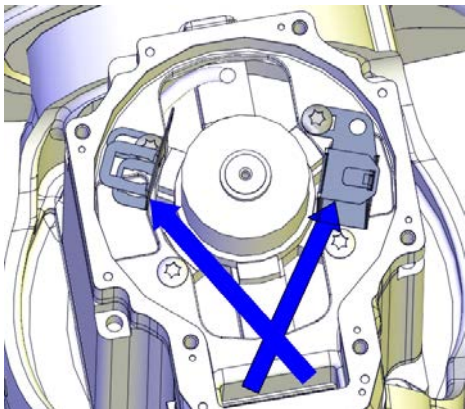

	Action	Note
5	<p>Secure the carrier with the M4 screw.</p> <p> Note</p> <p>The screw is located at the bottom of the carrier.</p> <p> Tip</p> <p>The attachment screw securing the carrier may be difficult to fit. Make sure the carrier is level and completely pressed against the bottom.</p>	 <p>xx130000485</p>
6	<p>Secure the cable bracket with its attachment screws.</p>	 <p>xx130000484</p>
7	<p>Reconnect the connectors to the axis-6 motor.</p> <p> Note</p> <p>Place the resolver cable under the motor cable.</p>	 <p>xx130000488</p>

Continues on next page

4 Repair

4.5.1 Replacing the upper arm

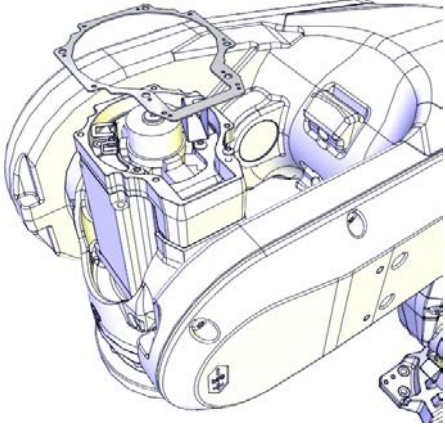
Continued

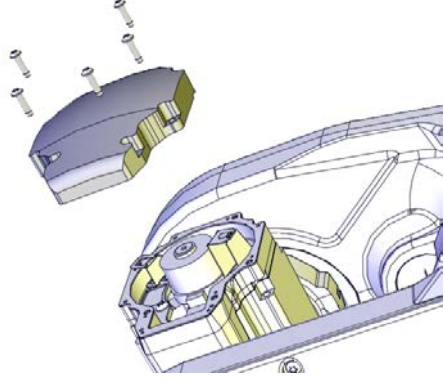
	Action	Note
8	Make sure the gasket is undamaged. Replace if damaged.	Gasket, 3HAC033489-001  xx1200001095
9	 CAUTION When fitting the motor cover, make sure that none of the cables inside will be damaged.	
10	Refit the motor cover.	 xx1200001080

Continues on next page

Refitting the wrist cover

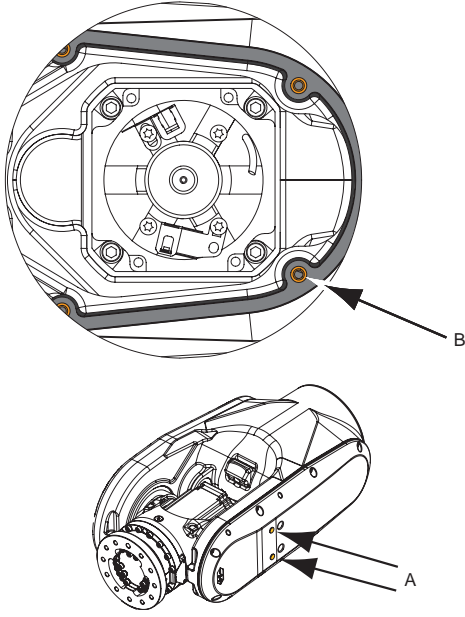
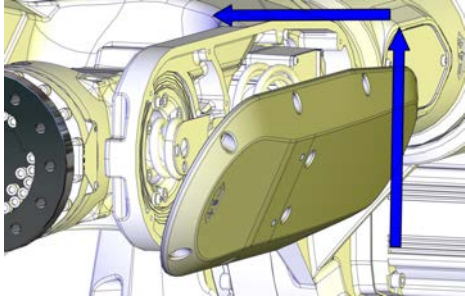
	Action	Note
1	<p>Foundry Plus: Inspect the gasket. Replace if damaged. Put washers in the holes of the gasket.</p>	 <p>xx140000383</p> <p>A Protection plugs (2 on wrist cover and 2 on cover axis-5 gearbox) B Washers (10 pcs) in gasket holes</p>
2	<p>Refit the wrist cover. In order not to damage the cable harness when the wrist cover is refitted, use this method:</p> <ol style="list-style-type: none"> 1 Hold the cover angled. See figure! 2 Catch any part of the cable harness hanging down. 3 Lift the cover, still held in an angle. 4 Move the upper part of the cover into position. 5 Secure the cover with its attachment screws. 	 <p>xx130000772</p> <p>Tightening torque: 10 Nm.</p>
3	<p>Remove the lifting accessories.</p>	



Continues on next page

4 Repair

4.5.1 Replacing the upper arm

Continued

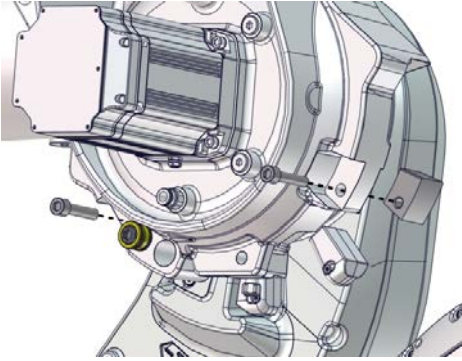
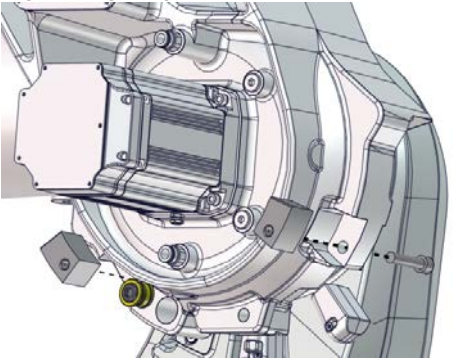
Concluding procedure

	Action	Note
1	Remove the service stops from maintenance position.	 <p>xx170000449</p>
2	Fit the service stops in their parking position.	<p>Tightening torque: 70 Nm \pm15 Nm.</p>  <p>xx170000448</p>
3	Re-calibrate the robot.	<p>Axis Calibration is described in Calibrating with Axis Calibration method on page 694. General calibration information is included in section Calibration on page 683.</p>
4	 DANGER Make sure all safety requirements are met when performing the first test run. See Test run after installation, maintenance, or repair on page 97 .	

4.5.2 Replacing the wrist

Strictly forbidden to open the cover on the axis-5 gearbox



Note

Do not, under any circumstances, open the cover on the axis-5 gearbox! It is strictly forbidden to do any repair work on the axis-5 gearbox.

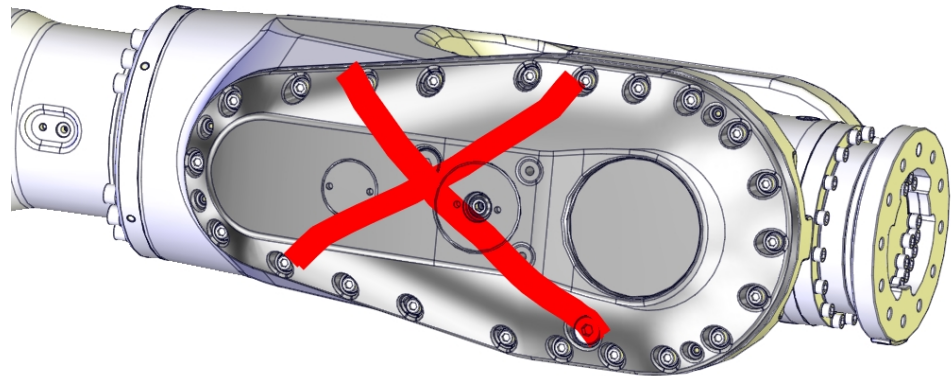

xx1300002248

Continues on next page

4 Repair

4.5.2 Replacing the wrist

Continued

Location of the wrist

The wrist is located as shown in the figure.

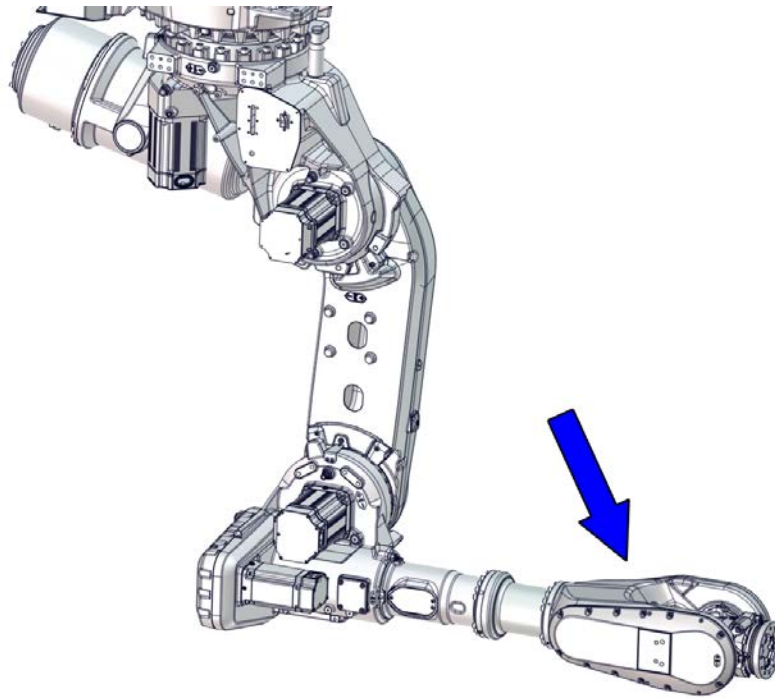

xx170000052

Spare part

Spare part	Spare part number	Note
Wrist	See <i>Product manual, spare parts - IRB 6700/IRB 6700Inv</i>	

Consumables

Equipment, etc.	Article number	Note
Cable tie	-	
Grease	3HAC042536-001	Shell Gadus S2 Used to lubricate o-rings.
O-ring	3HAC054692-001	D=119x3 Used on axis-5 motor cover.
Gasket	3HAC033489-001	Used on axis-6 motor cover.
Rust preventive	3HAC034903-001	Mercasol 3110 Waxcoat. Recommended drying time is 24h. Used on Foundry Plus.

Required tools and equipment

Equipment, etc.	Article number	Note
Roundsling, 1 m	-	Lifting capacity: 1,000 kg.

Continues on next page

Equipment, etc.	Article number	Note
Pallet		Used for putting down removed parts from robot.
Cardboard		Used for protection.
Guide pin, M12x150	3HAC13056-2	Always use guide pins in pairs.
24 VDC power supply	-	Used to release the motor brakes.
Calibration tool box, Axis Calibration	3HAC055412-001	Delivered as a set of calibration tools.
Standard toolkit	-	Content is defined in section Standard toolkit on page 724 .

Deciding calibration routine

Decide which calibration routine to be used, based on the information in the table. Depending on which routine is chosen, action might be required prior to beginning the repair work of the robot, see the table.

	Action	Note
1	Decide which calibration routine to use for calibrating the robot. <ul style="list-style-type: none"> Reference calibration. External cable packages (DressPack) and tools can stay fitted on the robot. Fine calibration. All external cable packages (DressPack) and tools must be removed from the robot. 	
	If the robot is to be calibrated with reference calibration: Find previous reference values for the axis or create new reference values. These values are to be used after the repair procedure is completed, for calibration of the robot. If no previous reference values exist, and no new reference values can be created, then reference calibration is not possible.	Follow the instructions given in the reference calibration routine on the FlexPendant to create reference values. Creating new values requires possibility to move the robot. Read more about reference calibration for Axis Calibration in Reference calibration routine on page 695 .
	If the robot is to be calibrated with fine calibration: Remove all external cable packages (DressPack) and tools from the robot.	

Removing the wrist

These procedures describes how to remove the wrist.

Preparations before removing the wrist



	Action	Note
1	Decide which calibration routine to use, and take actions accordingly prior to beginning the repair procedure.	
2	Remove tools and other equipment fitted to the wrist.	

Continues on next page

4 Repair

4.5.2 Replacing the wrist

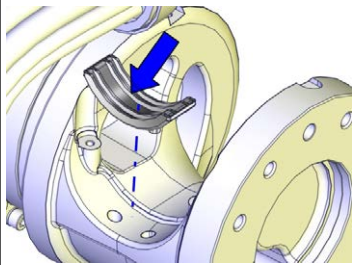
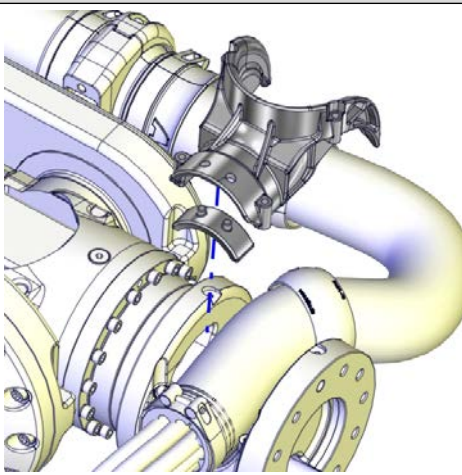
Continued

	Action	Note
3	<p>If used, open the DressPack axis-6 cable support and remove the DressPack cable package from the process turning disk.</p> <p> Note</p> <p>Use caution not to lose the two clamp jaws on either side of the DressPack cable package.</p>  <p>xx1400000223</p> <p>Clamp jaw</p>	 <p>xx1400000208</p>
4	<p>Jog the robot into position:</p> <ul style="list-style-type: none"> • Axis 1: no significance (as long as the robot is secured to the foundation) • Axis 2: 0° • Axis 3: 0° • Axis 4: -90° • Axis 5: +90° • Axis 6: no significance 	
5	<p> DANGER</p> <p>Turn off all:</p> <ul style="list-style-type: none"> • electric power supply • hydraulic pressure supply • air pressure supply <p>to the robot, before entering the safeguarded space.</p>	
6	<p>Prepare a pallet with cardboard in front of the robot or where it is possible, to be used for putting down the wrist unit on.</p>	

Retrieving access to the wrist cabling

Use this procedure to remove the wrist cover to retrieve access to the axis-5 and axis-6 motor cables.

	Action	Note
1	<p> DANGER</p> <p>Make sure that all supplies for electrical power, hydraulic pressure, and air pressure are turned off.</p>	

Continues on next page

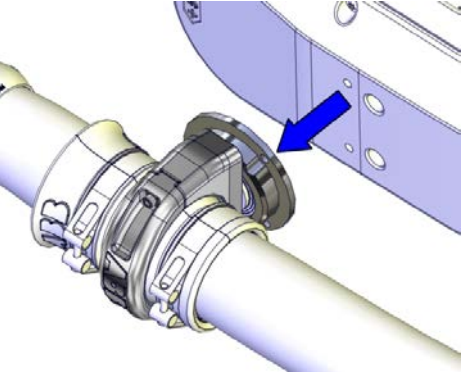
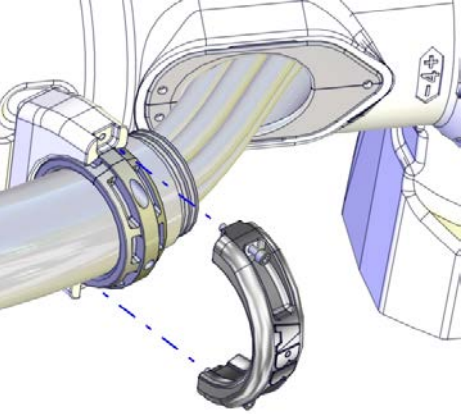
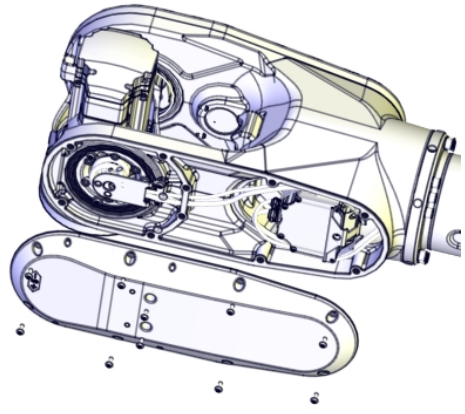

	Action	Note
2	<p>If DressPack is installed:</p> <ul style="list-style-type: none"> Remove the bracket with the complete ball joint housing still fitted, as shown in the figure. <p>This is done to be able to reach the two hidden screws that secure the wrist cover.</p>	 <p>xx140000355</p>
3	<p>If used, open the ball joint housing on the arm tube and remove the DressPack cable package.</p>	 <p>xx140000206</p>
4	<p>Remove the wrist cover.</p>	 <p>xx130000247</p>

Continues on next page

4 Repair

4.5.2 Replacing the wrist

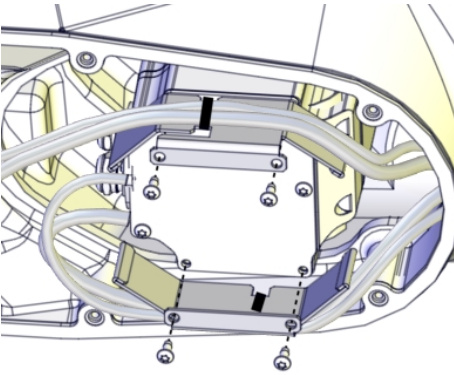

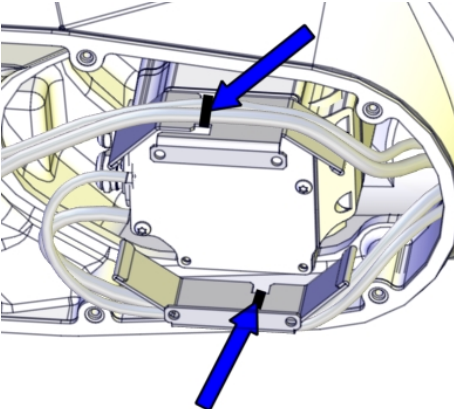
Continued

	Action	Note
5	Remove the heat protection plates from the motor with the cabling still attached to the plate.	 <p data-bbox="943 734 1050 757">xx1500001030</p>
6	<p data-bbox="464 786 932 846">Cut the cable ties that hold the cable harness to the plate.</p> <p data-bbox="464 864 932 925">  Note Keep the heat protection plate until refitting. </p> <p data-bbox="464 943 932 1003">  Tip If removing the plate only for replacing the motor, the cabling does not need to be loosened from the plate. </p>	 <p data-bbox="943 1211 1050 1234">xx1500001029</p>

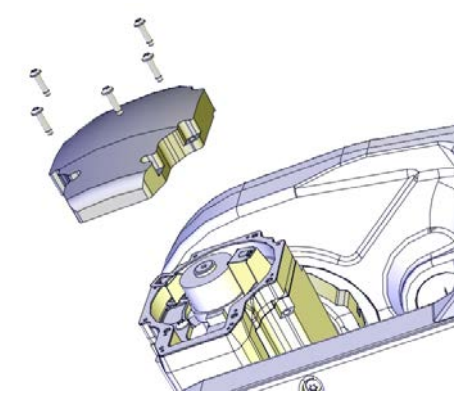
Disconnecting the axis-6 motor cables

	Action	Note
1	<p data-bbox="464 1373 932 1433">  DANGER Make sure that all supplies for electrical power, hydraulic pressure, and air pressure are turned off. </p>	
2	Unscrew the attachment screws and remove the motor cover.	 <p data-bbox="943 1977 1050 2000">xx1200001080</p>

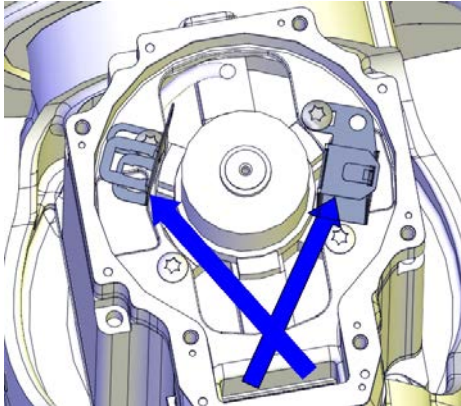
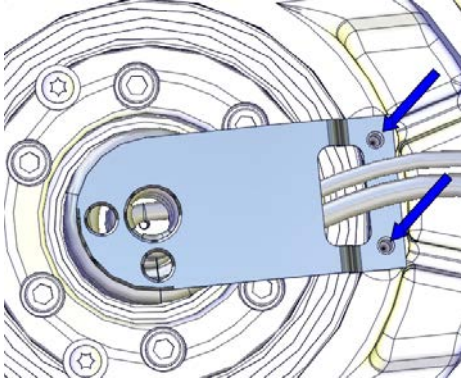
Continues on next page

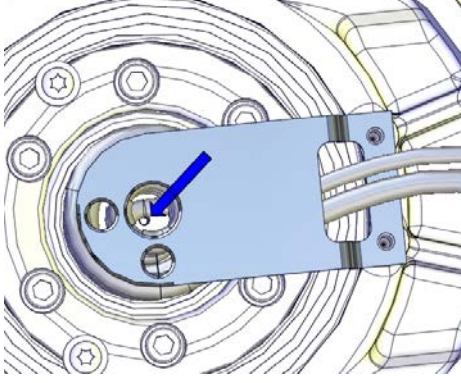
	Action	Note
3	Disconnect the motor cables.	 <p>xx130000488</p>
4	Unscrew the attachment screws that hold the cable bracket.	 <p>xx130000484</p>
5	Unscrew the M4 screw that holds the carrier.  Note The screw is located at the bottom of the carrier.	 <p>xx130000485</p>

Continues on next page

4 Repair

4.5.2 Replacing the wrist

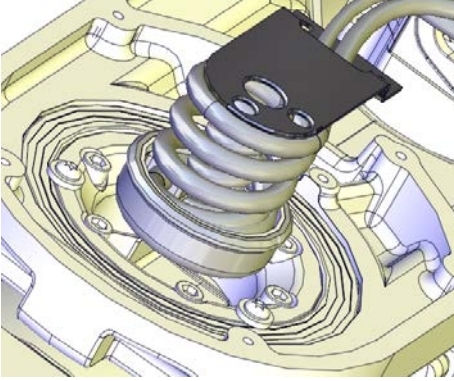
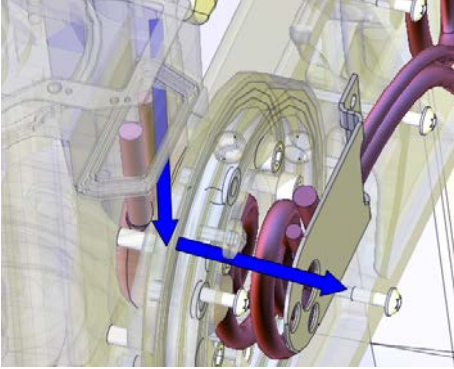

Continued

	Action	Note
6	Pull out the carrier from its position.	 <p>xx1300001113</p>
7	Pull out the axis-6 motor cables by holding the cables with one hand at the motor and the other at the carrier.	 <p>xx1300000666</p>

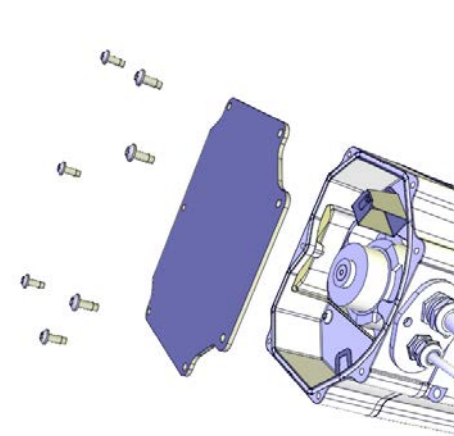
Disconnecting the axis-5 motor cables

	Action	Note
1	 DANGER Make sure that all supplies for electrical power, hydraulic pressure, and air pressure are turned off.	
2	Unscrew the attachment screws and washers and remove the motor cover.	 <p>xx1200001135</p>

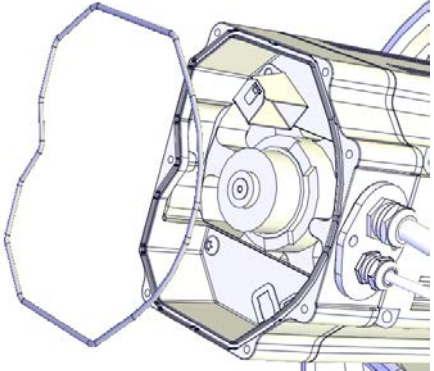
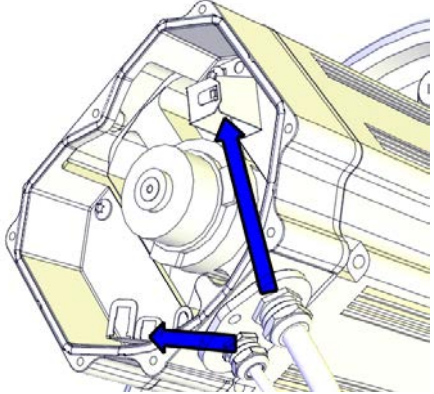
Continues on next page

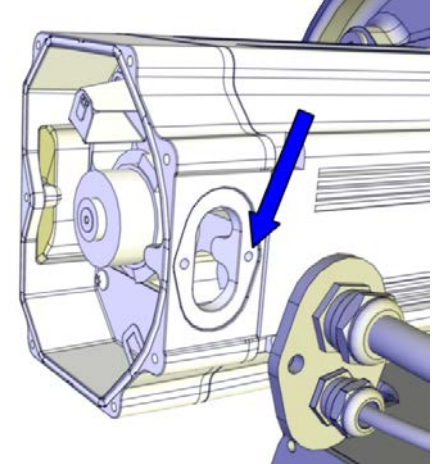
	Action	Note
3	Make sure the o-ring is present.	 <p>xx1200001070</p>
4	Disconnect the motor cables.	 <p>xx1200001066</p>
5	<p>Remove the cable gland cover by performing the following steps:</p> <ol style="list-style-type: none"> 1 Open the inner screw a little (the one the arrow is pointing at). No need to remove this screw from the motor. 2 Remove the outer screw. 3 Slide the cable gland cover away from the inner screw. Make sure the gasket is not damaged. <p> Tip</p> <p>Make a note in which direction the cable exit hole is facing, if the motor will be removed too. The motor shall be refitted in the same position.</p>	 <p>xx1300000656</p>
6	Use caution and pull out the motor cables.	





Continues on next page

4 Repair

4.5.2 Replacing the wrist

Continued

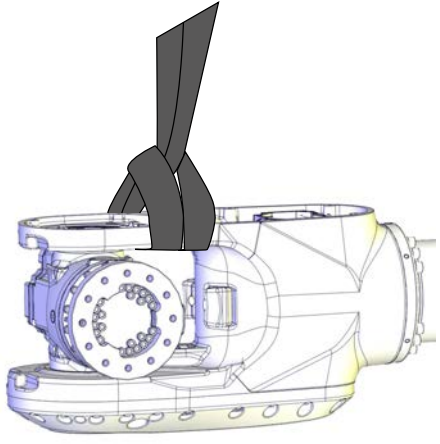

Attaching the lifting accessories to the wrist

	Action	Note
1	<p> CAUTION</p> <p>The weight of the complete wrist is 140 kg All lifting accessories used must be sized accordingly.</p>	
2	<p>Attach a roundsling to the wrist as shown in the figure.</p> <p> CAUTION</p> <p>It is very important that the roundsling is placed as shown in the figure, to keep the wrist balanced when it is removed. Placed at a different position, there is a risk of sudden change in the balance, which can cause damage or injury. Do not attach the roundsling around the axis-5 gearbox!</p>	<p>Roundsling, 1 m: Lifting capacity: 1,000 kg.</p>  <p>xx1300000673</p>
3	<p> Note</p> <p>Make sure the roundsling is stretched, so it can carry the weight of the wrist.</p>	

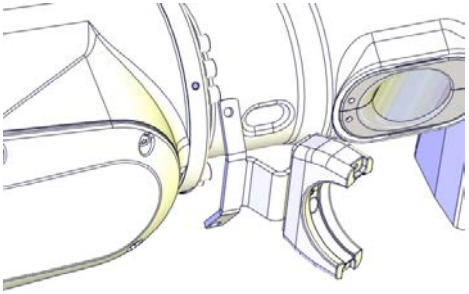
Removing the wrist

	Action	Note
1	<p>If used, remove the bracket with the part of the ball joint housing still fitted.</p>	 <p>xx1700000691</p>

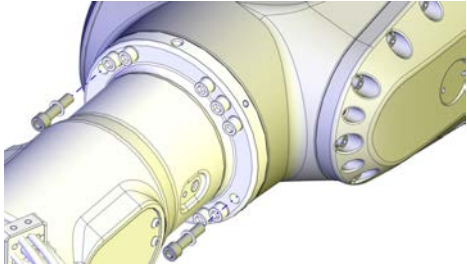
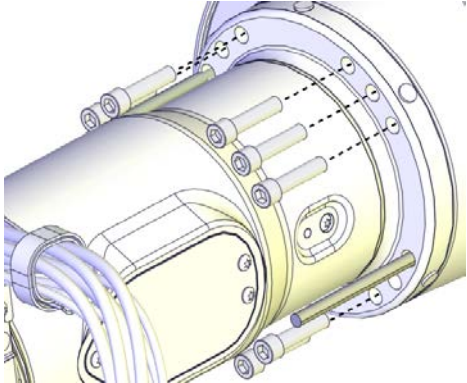
Continues on next page

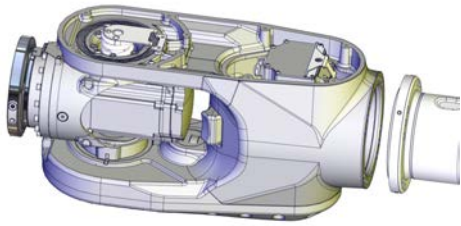
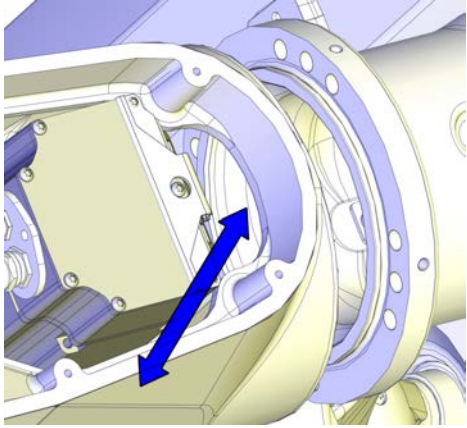
	Action	Note
2	<p>Remove two attachment screws in opposite holes and replace them with guide pins.</p> <p> Tip</p> <p>Lubricate the guide pins with some grease to make the wrist slide better.</p>	<p>Guide pin, M12x150: 3HAC13056-2 Always use guide pins in pairs.</p>  <p>xx130000748</p>
3	<p>Remove the remaining attachment screws.</p>	 <p>xx130000749</p>
4	<p>Pull out the wrist a bit, onto the guide pins. This is done to be able to remove the cable harness from the wrist in a safe way.</p> <p> CAUTION</p> <p>Make sure that the cabling does not get damaged.</p>	 <p>xx130000750</p>
5	<p>Use caution and pull out the cabling from the wrist unit.</p>	 <p>xx130000769</p>

Continues on next page

4 Repair

4.5.2 Replacing the wrist

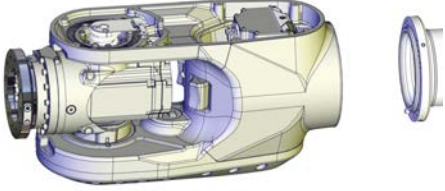

Continued

	Action	Note
6	Slide the wrist off the guide pins and put it on a pallet or similar.	 <p>xx1300000770</p>

Refitting the wrist

These procedures describes how to refit the wrist.

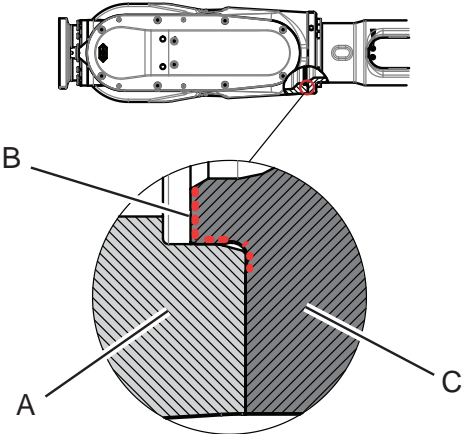

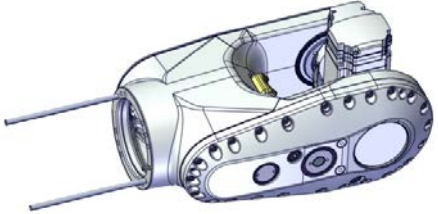

Preparations before refitting the wrist

	Action	Note
1	 DANGER Make sure that all supplies for electrical power, hydraulic pressure, and air pressure are turned off.	
2	Wipe clean all contact surfaces.	
3	Foundry Plus: Apply Mercasol on the surfaces shown in the figure.	 <p>xx1400000371</p>
4	Fit two guide pins in opposite holes in the wrist.  Tip Lubricate the guide pins with some grease to make the wrist slide better.	Guide pin, M12x150: 3HAC13056-2 Always use guide pins in pairs.  <p>xx1700001595</p>

Continues on next page

	Action	Note
5	<p>If axis-5 is not already in position +90°, connect the 24 VDC power supply, release the brakes and move the axis manually into that position.</p> <p>Connect to R2.MP5-connector:</p> <ul style="list-style-type: none"> • + = pin 2 • - = pin 5 	24 VDC power supply

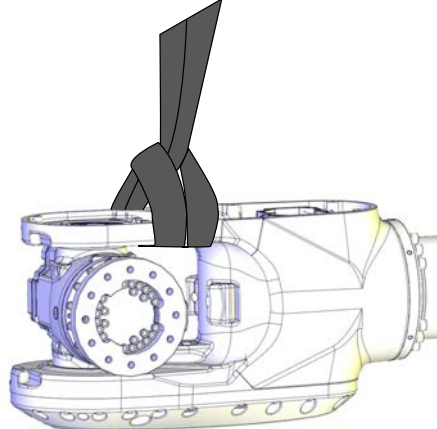
Attaching the lifting accessories to the wrist

	Action	Note
1	<p> CAUTION</p> <p>The weight of the complete wrist is 140 kg All lifting accessories used must be sized accordingly.</p>	
2	<p>Attach a roundsling to the wrist as shown in the figure.</p> <p> CAUTION</p> <p>It is very important that the roundsling is placed as shown in the figure, to keep the wrist balanced when it is removed. Placed at a different position, there is a risk of sudden change in the balance, which can cause damage or injury.</p> <p>Do not attach the roundsling around the axis-5 gearbox!</p>	<p>Roundsling, 1 m: Lifting capacity: 1,000 kg.</p>  <p>xx130000673</p>
3	<p> Note</p> <p>Make sure the roundsling is stretched, so it can carry the weight of the wrist.</p>	

Refitting the wrist

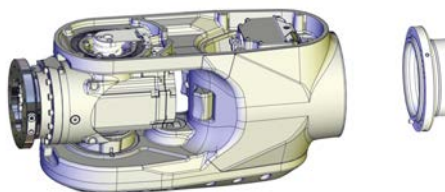
	Action	Note
1	<p>Lift the wrist and insert the guide pins into the holes of the arm tube.</p> <p> Tip</p> <p>Leave a small opening between wrist and arm tube. This will make it easier to run the cable harness back into the wrist.</p>	 <p>xx130000770</p>

Continues on next page

4 Repair

4.5.2 Replacing the wrist

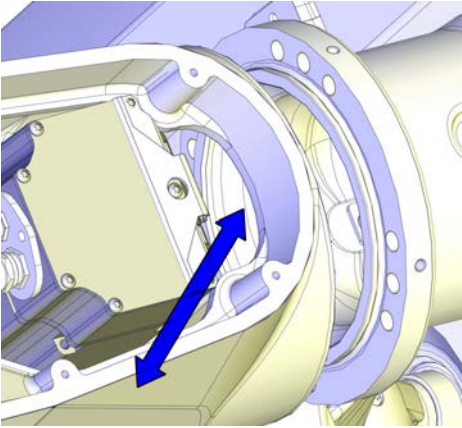
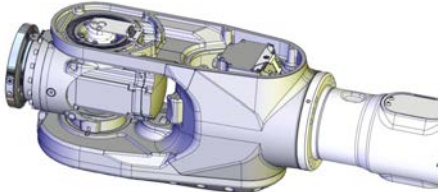
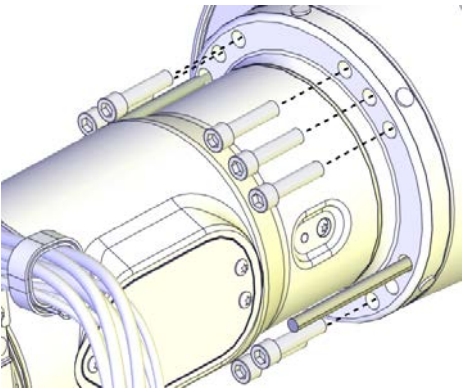
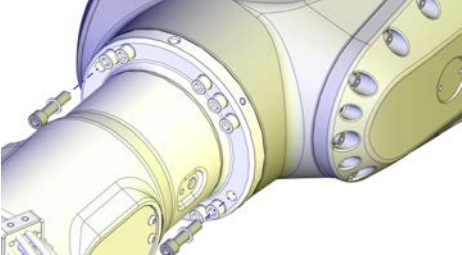

Continued

	Action	Note
2	Run the cabling into the wrist unit. Be careful not to damage any part of the cable harness.	 xx130000769
3	Mount the four sealing plate nuts on the tube shaft.	
4	Slide the wrist into fitting position.	 xx130000771
5	Fit 10 of the 12 attachment screws and washers.	Screws: M12x50.  xx130000749
6	Remove the guide pins and replace them with the remaining attachment screws and washers.	 xx130000748

Continues on next page

	Action	Note
7	Tighten the attachment screws.	Tightening torque: 120 Nm.

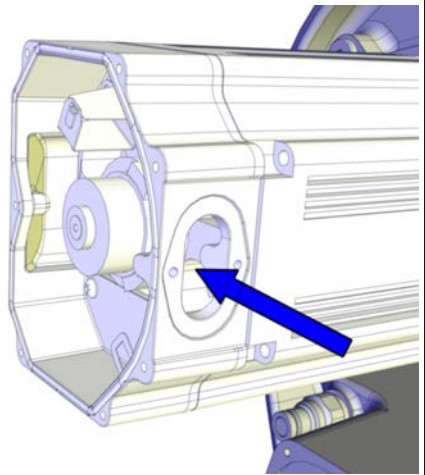
Connecting the axis-5 motor cables

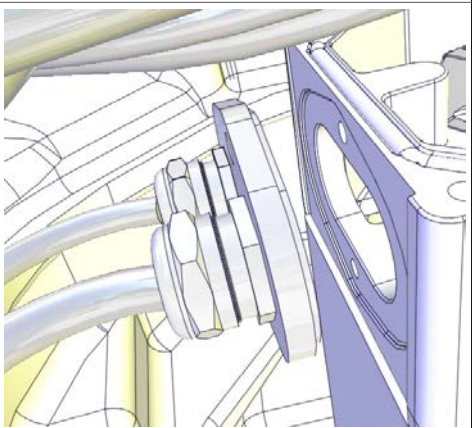
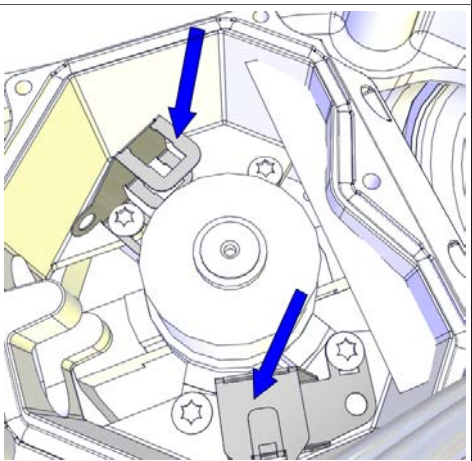



	Action	Note
1	Push the motor cables in through the cable gland opening.	 <p>xx1300000738</p>
2	Refit the cable gland cover by performing the following steps: <ul style="list-style-type: none"> • Slide the cable gland cover onto the inner screw. • Refit and tighten the outer screw. • Tighten the inner screw. Make sure that the gasket is not damaged.  Note Replace the gasket if damaged.	 <p>xx1200001016</p>
3	Connect the connectors. Connect in accordance with the markings on the connectors.	 <p>xx1200001015</p>

Continues on next page

4 Repair

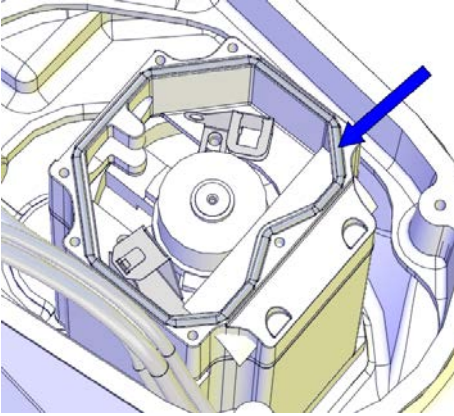
4.5.2 Replacing the wrist

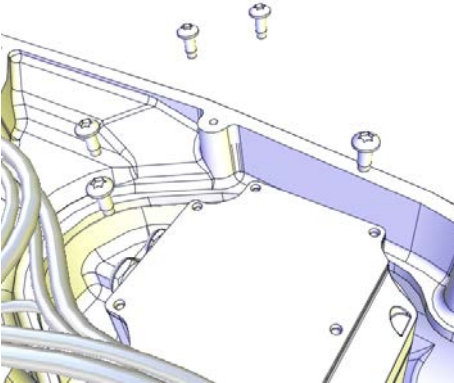
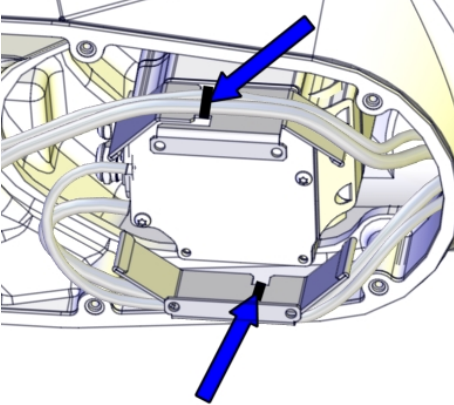

Continued

	Action	Note
4	<p>Make sure the o-ring on the motor is undamaged. Replace if damaged.</p>	<p>O-ring, axis 5: 3HAC054692-001.</p>  <p>xx1200001021</p>
5	<p> CAUTION</p> <p>When fitting the motor cover, make sure that none of the cables inside will be damaged.</p>	
6	<p>Refit the motor cover with its attachment screws.</p> <p> Note</p> <p>Do not refit the screws that will hold the heat protection plate at this point.</p> <p> Note</p> <p>Do not reuse the self-threading attachment screws, it will damage the threads. Replace with standard attachment screws.</p> <p> Note</p> <p>Make sure the o-ring is undamaged and properly fitted.</p>	<p>Screws: M5x12.</p>  <p>xx1200001013</p>
7	<p>Secure the cable harness with cable straps to the heat protection plate.</p>	 <p>xx1500001029</p>

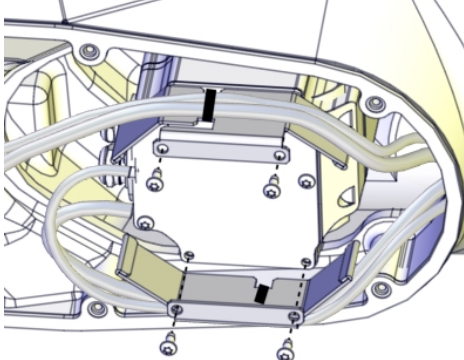
Continues on next page

	Action	Note
8	Fit the heat protection plate with the screws.	<p>Screws: M5x12.</p>  <p>xx1500001030</p>

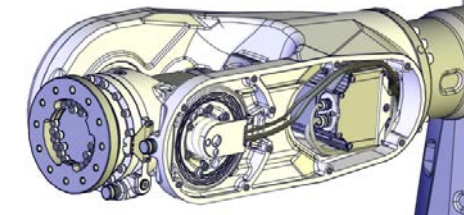
Connecting the axis-6 motor cables

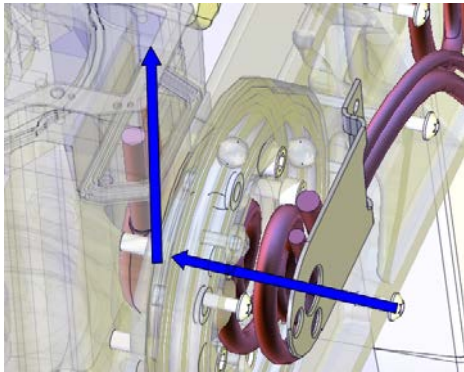

	Action	Note
1	Make sure that the cable harness is placed in a way that it will not be damaged when the cover is fitted.	 <p>xx1600002061</p>
2	<p> Note</p> <p>Axis 5 must be in position +90° (or as close as possible) for a correct installation of the cable harness in the wrist. If not, connect the 24 VDC power supply, release the brakes and move axis 5 manually to +90°.</p>	Position +90° of axis 5 makes the turning disc face the floor, if the robot is floor standing.
3	Push the cable harness into the wrist recess and up into the axis-6 motor.	 <p>xx1300000667</p>

Continues on next page

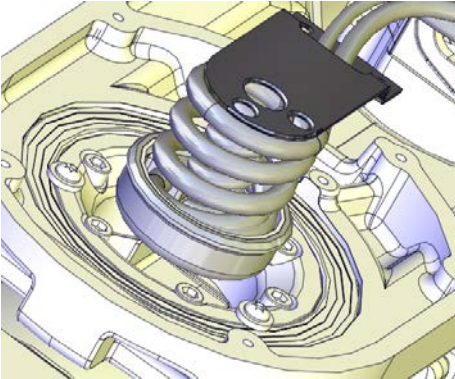

4 Repair

4.5.2 Replacing the wrist

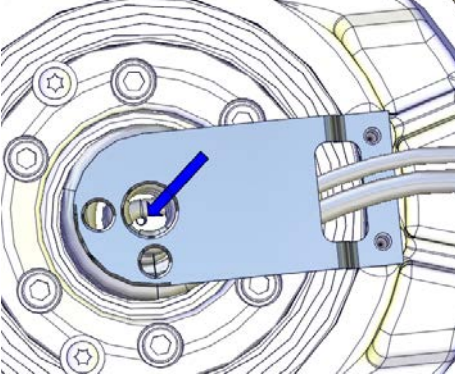
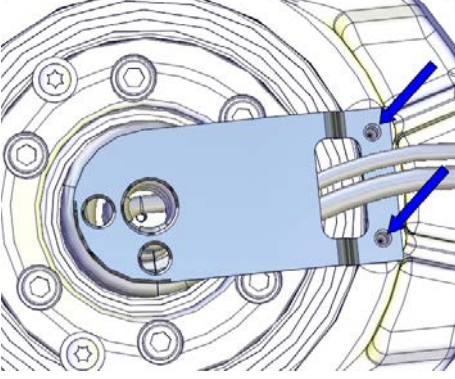
Continued

	Action	Note
4	Push the carrier carefully into position.	 xx1300001113
5	<p>Secure the carrier with the M4 screw.</p> <p> Note</p> <p>The screw is located at the bottom of the carrier.</p> <p> Tip</p> <p>The attachment screw securing the carrier may be difficult to fit. Make sure the carrier is level and completely pressed against the bottom.</p>	 xx1300000485
6	Secure the cable bracket with its attachment screws.	 xx1300000484

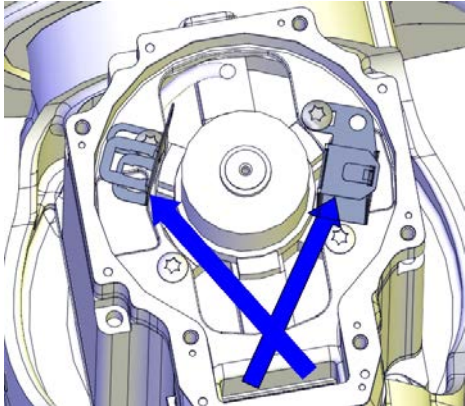
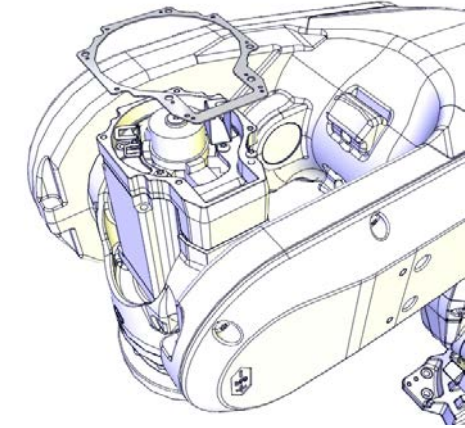
Continues on next page

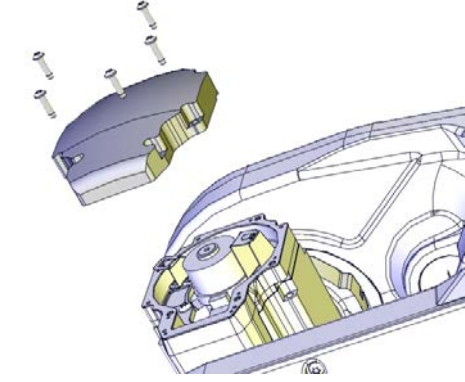
	Action	Note
7	<p>Reconnect the connectors to the axis-6 motor.</p> <p> Note</p> <p>Place the resolver cable under the motor cable.</p>	 <p>xx130000488</p>
8	<p>Make sure the gasket is undamaged. Replace if damaged.</p>	<p>Gasket, 3HAC033489-001</p>  <p>xx1200001095</p>
9	<p> CAUTION</p> <p>When fitting the motor cover, make sure that none of the cables inside will be damaged.</p>	
10	<p>Refit the motor cover.</p>	 <p>xx1200001080</p>

Continues on next page

4 Repair

4.5.2 Replacing the wrist

Continued

Concluding procedure

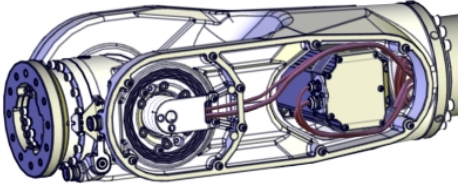
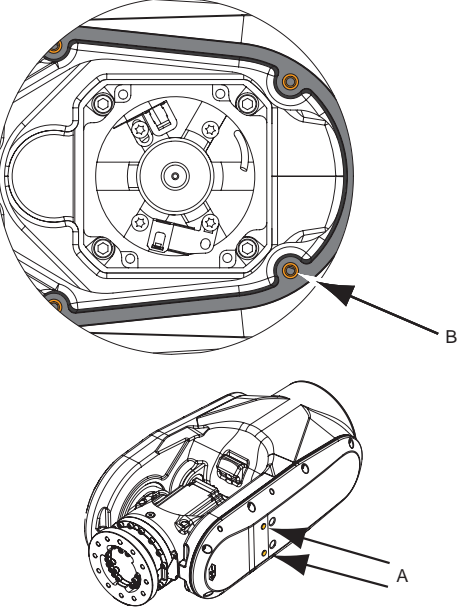
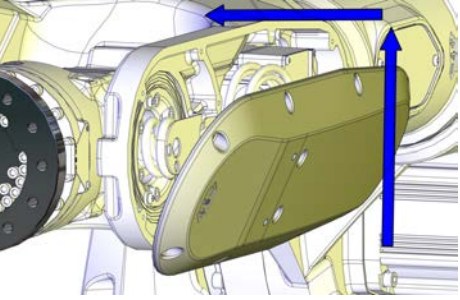
	Action	Note
1	<p>Make sure that the cable harness is placed in a way so it will not be damaged when the wrist cover is fitted.</p>	 <p>xx1500001672</p>
2	<p>Foundry Plus: Inspect the gasket. Replace if damaged. Put washers in the holes of the gasket.</p>	 <p>xx1400000383</p> <p>A Protection plugs (2 on wrist cover and 2 on cover axis-5 gearbox) B Washers (10 pcs) in gasket holes</p>
3	<p>Refit the wrist cover. Use this method not to damage the cable harness:</p> <ol style="list-style-type: none"> 1 Hold the cover tilted. See figure! 2 Catch any part of the cable harness hanging down. 3 Lift the cover, still held tilted. 4 Move the upper part of the cover into position. 5 Secure the cover with its attachment screws. 	 <p>xx1300000772</p> <p>Tightening torque: 10 Nm.</p>
4	<p>Foundry Plus: Refit protection plugs.</p>	
5	<p>If used, refit the DressPack cable package on the wrist.</p>	

Continues on next page

	Action	Note
6	Re-calibrate the robot.	Axis Calibration is described in Calibrating with Axis Calibration method on page 694 . General calibration information is included in section Calibration on page 683 .
7	 DANGER Make sure all safety requirements are met when performing the first test run. See Test run after installation, maintenance, or repair on page 97 .	

4 Repair

4.5.3 Replacing the turning disc

4.5.3 Replacing the turning disc

Location of the turning disc

The turning disc is located in the front of the wrist housing as shown in the figure.

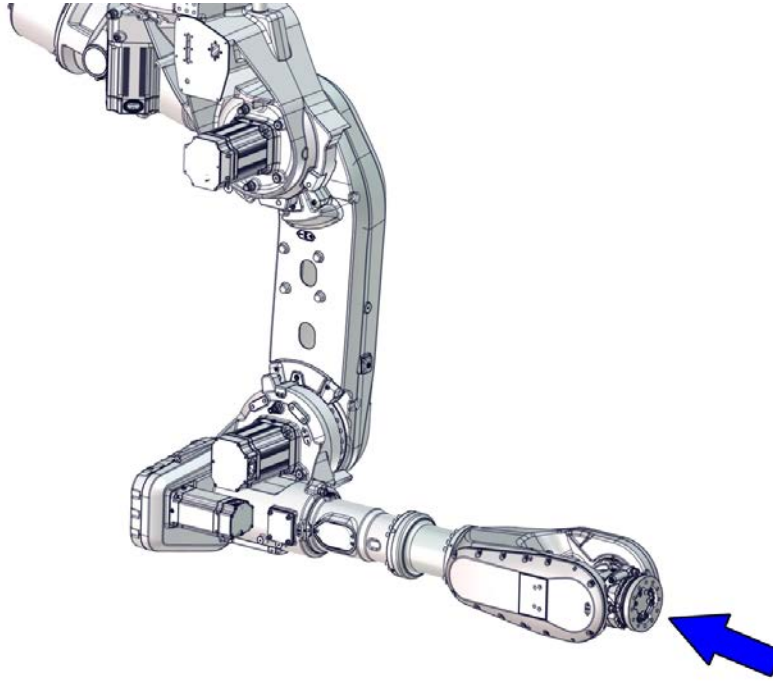

xx170000053

Spare part

Spare part	Spare part number	Note
Turning disc	See <i>Product manual, spare parts - IRB 6700/IRB 6700Inv</i>	

Consumables

Equipment, etc.	Article number	Note
Rust preventive	3HAC034903-001	Mercasol 3110 Waxcoat. Recommended drying time is 24h. Used on Foundry Plus.

Required tools and equipment

Equipment, etc.	Article number	Note
Standard toolkit	-	Content is defined in section Standard toolkit on page 724 .

Continues on next page

Removing the turning disc

Use these procedures to remove the turning disc.

Preparations before removing the turning disc

	Action	Note
1	Run the robot to a position most comfortable for the removal of the turning disc.	
2	 DANGER Turn off all: <ul style="list-style-type: none"> • electric power supply • hydraulic pressure supply • air pressure supply to the robot, before entering the safeguarded space.	
3	Remove any equipment fitted to the turning disc.	

Removing the turning disc

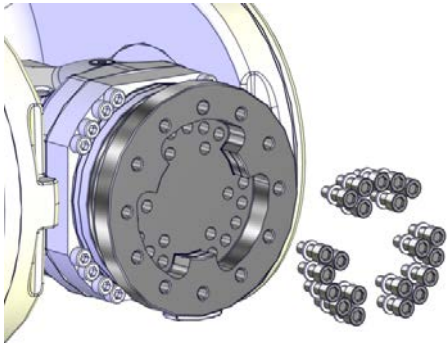
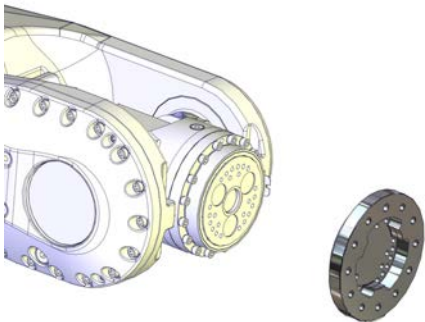
	Action	Note
1	Remove the screws and washers, that secure the turning disc.	 <p>xx1400002195</p>
2	Remove the turning disc.	 <p>xx1300000493</p>

Continues on next page

4 Repair

4.5.3 Replacing the turning disc

Continued

Replacing the synchronization mark plate

The design of the turning disc spare part might require replacement of the axis-6 synchronization mark plate if the existing plate is not compatible with the new turning disc.

If ordering a new turning disc, the synchronization mark plate required is enclosed with the spare part. Check if the robot is already equipped with a compatible plate or if it needs to be replaced. The difference is shown in the figures.

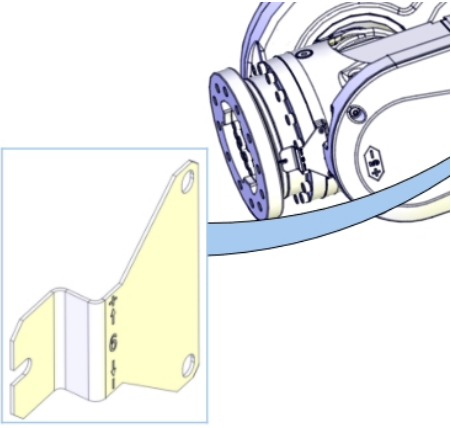
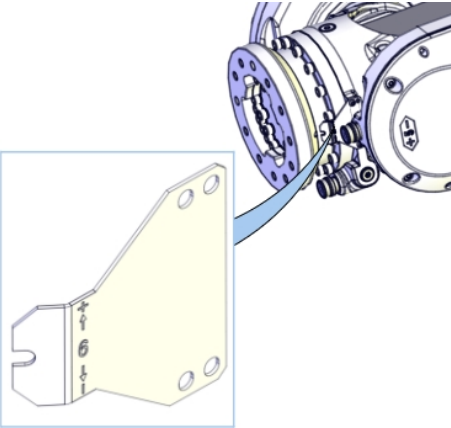
Incompatible axis-6 synchronization mark plate on robot	Compatible axis-6 synchronization mark plate on robot
 <p>xx1500000873</p> <p>Incompatible synchronization mark plate is installed. Replace the plate.</p>	 <p>xx1500000874</p> <p>Compatible synchronization mark plate is installed. No action required.</p>

Refitting the turning disc

Use this procedure to refit the turning disc.

Refitting the turning disc

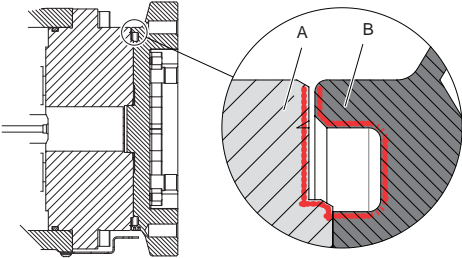
	Action	Note
1	If new turning disc spare part is installed: verify that the correct synchronization mark plate for axis-6 is installed on the wrist.	See Replacing the synchronization mark plate on page 338 .
2	Wipe clean the contact surfaces.	
3	Foundry Plus: Apply Mercasol on the surfaces on turning disc and axis-6 gearbox as shown in the figure.	 <p>xx1400000385</p>

Continues on next page

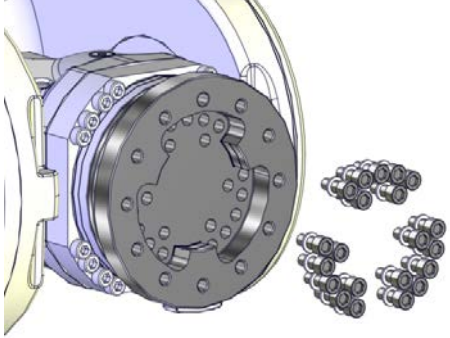
	Action	Note
4	Secure the turning disc with its attachment screws and washers.	<p>Tightening torque: 70 Nm Attachment screws: M10x25, Steel 12.9 Gleitmo 603, (21 pcs) Washers: Steel (21 pcs)</p>  <p>xx1400002195</p>

Concluding procedure

	Action	Note
1	 <p>DANGER</p> <p>Make sure all safety requirements are met when performing the first test run. See Test run after installation, maintenance, or repair on page 97.</p>	

4 Repair

4.5.4 Replacing the process turning disc

4.5.4 Replacing the process turning disc

Location of the process turning disc

The process turning disc is located in the front of the wrist housing as shown in the figure.

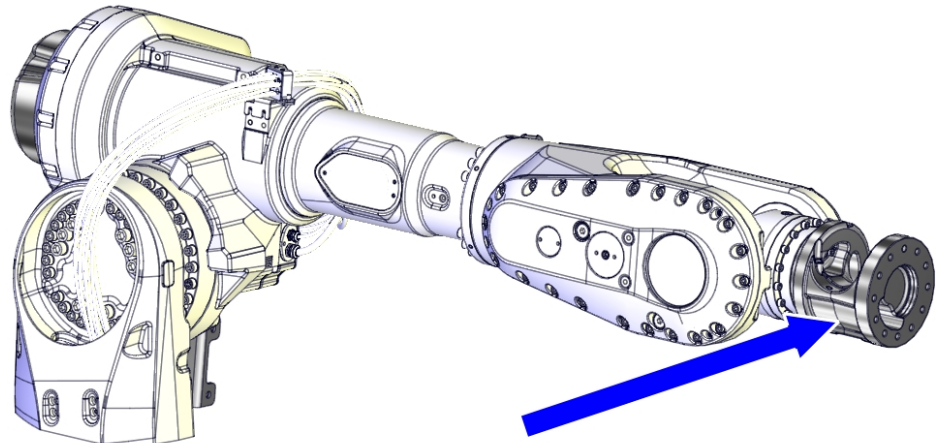

xx1400001391

Required tools and equipment

Equipment, etc.	Article number	Note
Standard toolkit	-	Content is defined in section Standard toolkit on page 724 .

Consumables

Equipment, etc.	Article number	Note
Rust preventive	-	Mercasol, used on Foundry Plus

Removing the process turning disc

Use these procedures to remove the process turning disc.

Preparations before removing the process turning disc

	Action	Note
1	Run the robot to a position most comfortable for the removal of the process turning disc.	

Continues on next page

Action	Note
<p>2</p>  <p>DANGER</p> <p>Turn off all:</p> <ul style="list-style-type: none"> • electric power supply • hydraulic pressure supply • air pressure supply <p>to the robot, before entering the safe-guarded space.</p>	
<p>3</p> <p>Remove any equipment fitted to the process turning disc.</p>	

Removing the process turning disc

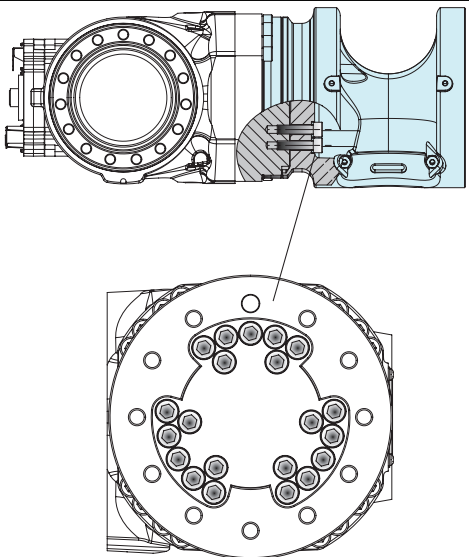
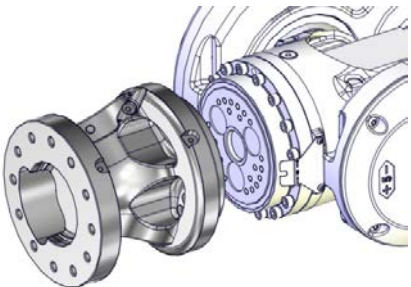
Action	Note
<p>1</p> <p>Remove the 21 M10 screws and washers, that secure the process turning disc.</p>	 <p>xx1400001395</p>
<p>2</p> <p>Remove the process turning disc.</p>	 <p>xx1400001393</p>

Refitting the process turning disc

Use this procedure to refit the process turning disc.

Refitting the process turning disc

Action	Note
<p>1</p> <p>Wipe clean the contacts surfaces.</p>	

Continues on next page

4 Repair

4.5.4 Replacing the process turning disc

Continued

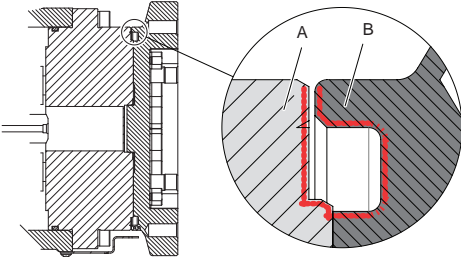
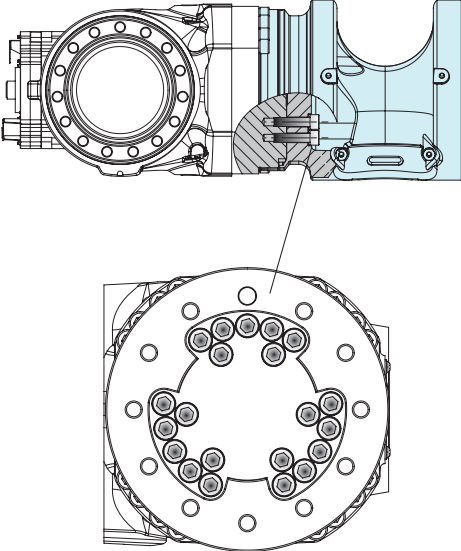
	Action	Note
2	<p>Foundry Plus: Apply Mercasol on the surfaces on the process turning disc and axis-6 gearbox as shown in the figure.</p>	 <p>xx140000385</p> <p>The figure show standard turning disc. Surfaces to apply Mercasol on are the same with process turning disc.</p>
3	<p>Secure the process turning disc with its attachment screws and washers.</p>	<p>Tightening torque: 70 Nm Attachment screws: M10x25, Steel 12.9 Gleitmo 603, (21 pcs) Washers: Steel (21 pcs)</p>  <p>xx1400001395</p>

Concluding procedure

	Action	Note
1	 <p>DANGER</p> <p>Make sure all safety requirements are met when performing the first test run. See Test run after installation, maintenance, or repair on page 97.</p>	

4.5.5 Replacing the lower arm

Location of the lower arm

The lower arm is located as shown in the figure.

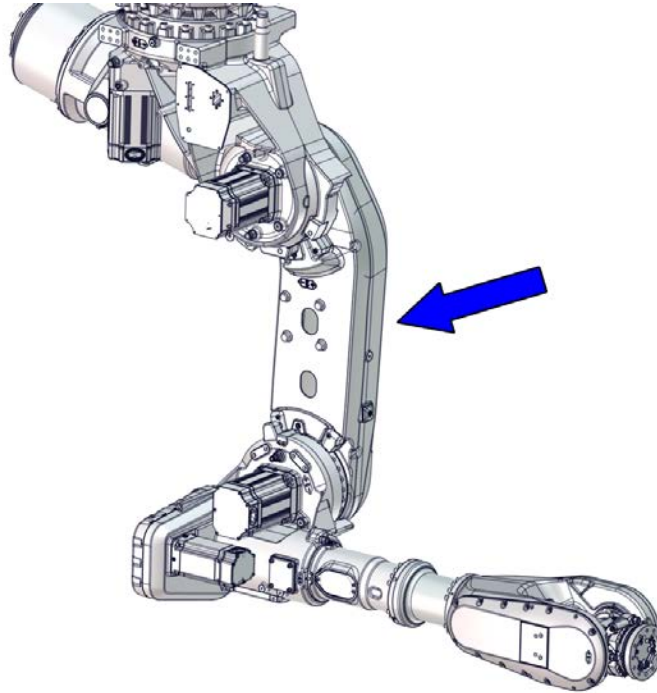

xx170000054



Note

The robot must be taken down and secured floor standing to perform this replacement procedure.

How to do this is described in the removal procedure in this section.



DANGER

Always lock the position of the lower arm, using the yellow sleeve and transportation lock screw, before attempting to lift the robot.

Summary of the replacement procedure

This is a brief summary of the replacement procedure, containing the major actions to be performed.

- 1 Lift down the robot to floor standing.
- 2 Unload the balancing device.
- 3 Remove the shaft in the balancing device front link ear
- 4 Remove the cabling from the upper and lower arm.
- 5 Remove the upper arm.
- 6 Replace the lower arm.

Continues on next page

4 Repair

4.5.5 Replacing the lower arm

Continued

Spare part

Spare part	Spare part number	Note
Lower arm	See <i>Product manual, spare parts - IRB 6700/IRB 6700Inv</i>	

Consumables

Equipment	Article number	Note
Bearing grease	3HAC042536-001	Shell Gadus S2 For lubrication of the front bearing of the balancing device.
Grease	3HAC042536-001	Shell Gadus S2 Used to lubricate o-rings.
O-ring	3HAC054692-002	D=169.5x3 Used on axis-3 motor cover.
	3HAC054692-001	D=119x3 Used on axis-4 motor cover.
	3HAC054692-001	D=119x3 Used on axis-5 motor cover.
Gasket	3HAC033489-001	Used on axis-6 motor cover.
Rust preventive	3HAC034903-001	Mercasol 3110 Waxcoat. Recommended drying time is 24h. Used on Foundry Plus.

Required tools and equipment

Equipment	Article number	Note
Fork lift accessory set	3HAC058825-001	Contains fork lift pockets and all required hardware for installation. User instructions are enclosed with the tool, see Directions for use - Fork lift accessory 3HAC058825-001. In order to rotate the robot, either use the turning tool or a fork lift truck with a rotator attachment.
Turning tool	3HAC073537-001	Lift and rotation of inverted robot. Requires fork lift accessory set 3HAC058825-001. User instructions are enclosed with the tool.
Relief screws	3HAC058129-001	Used for unloading the balancing device. Included in spare part balancing device.
Lifting shackle, 2 pcs	-	SA-10-8-NA1
Roundsling, 1 m	-	Lifting capacity: 1,000 kg.
Dismantle and mounting tool set	3HAC028920-001	Used for removing and fitting shaft and bearings.

Continues on next page

Equipment	Article number	Note
Threaded bar, M16x340	-	
Hydraulic cylinder	3HAC11731-1	To be used with the press tool.
Hydraulic pump 80 MPa	3HAC13086-1	To be used with the hydraulic cylinder.
Lifting eye, M12	3HAC16131-1	
Lifting eye, M12	3HAC16131-1	
Fender washer	-	Outer diameter: minimum 26 mm, maximum 30 mm, hole diameter: 13 mm, thickness: 3 mm.
Lifting accessory (chain)	3HAC15556-1	Lifting instruction 3HAC15880-2 enclosed.
Pallet		Used for putting down removed parts from robot.
Guide pin, M16x150	3HAC13120-2	Always use guide pins in pairs.
Guide pin, M16x200	3HAC13120-3	Always use guide pins in pairs.
Rotation tool	3HAB7887-1	Used to rotate the motor pinion.
24 VDC power supply	-	Used to release the motor brakes.
Calibration tool box, Axis Calibration	3HAC055412-001	Delivered as a set of calibration tools.
Standard toolkit	-	Content is defined in section Standard toolkit on page 724 .

Required documents

Document	Document number
Directions for use - Fork lift accessory 3HAC058825-001	3HAC060303-001
Directions for use - Lifting and rotating accessory for IRB 6700Inv/IRB6700I	3HAC073537-003

Deciding calibration routine

Decide which calibration routine to be used, based on the information in the table. Depending on which routine is chosen, action might be required prior to beginning the repair work of the robot, see the table.

	Action	Note
1	Decide which calibration routine to use for calibrating the robot. <ul style="list-style-type: none"> Reference calibration. External cable packages (DressPack) and tools can stay fitted on the robot. Fine calibration. All external cable packages (DressPack) and tools must be removed from the robot. 	

Continues on next page

4 Repair

4.5.5 Replacing the lower arm

Continued

Action	Note
<p>If the robot is to be calibrated with reference calibration: Find previous reference values for the axis or create new reference values. These values are to be used after the repair procedure is completed, for calibration of the robot.</p> <p>If no previous reference values exist, and no new reference values can be created, then reference calibration is not possible.</p>	<p>Follow the instructions given in the reference calibration routine on the FlexPendant to create reference values.</p> <p>Creating new values requires possibility to move the robot.</p> <p>Read more about reference calibration for Axis Calibration in Reference calibration routine on page 695.</p>
<p>If the robot is to be calibrated with fine calibration: Remove all external cable packages (DressPack) and tools from the robot.</p>	

Removing the lower arm

Use these procedures to remove the lower arm.

Preparations before removing the lower arm

Action	Note
1	Decide which calibration routine to use, and take actions accordingly prior to beginning the repair procedure.
2	<p> DANGER</p> <p>Turn off all:</p> <ul style="list-style-type: none"> • electric power supply • hydraulic pressure supply • air pressure supply <p>to the robot, before entering the safeguarded space.</p>
3	Remove all equipment fitted to upper and lower arms.

Securing the lower arm

Use this procedure to secure the lower arm.

Action	Note
1	Jog axis 2 to -35° .
2	Remove the transportation lock screw and the yellow sleeve from the parking position.

xx1700000270

Continues on next page

4.5.5 Replacing the lower arm
Continued

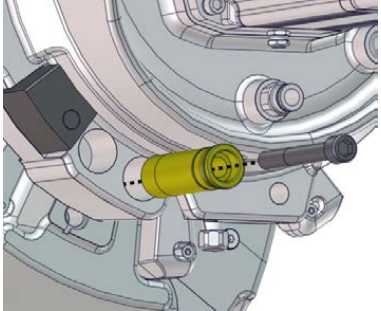
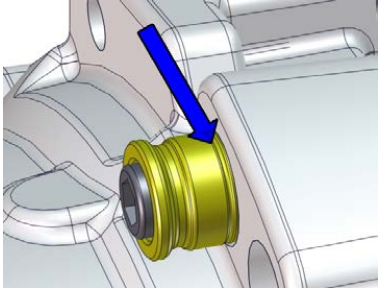
	Action	Note
3	<p>Insert the yellow sleeve and the transportation lock screw in the hole at the locking position. Insert the sleeve all the way so that the marking in the sleeve is aligned with the casting, see figure.</p> <p>Tighten the screw.</p> <p> DANGER</p> <p>Always use the transportation lock screw and sleeve to lock the lower arm at transportation, turning and floor standing.</p>	<p>Tightening torque: 70 Nm ±15 Nm.</p>  <p>xx1700000269</p>  <p>xx1600002114</p>

Lifting down the robot from inverted position

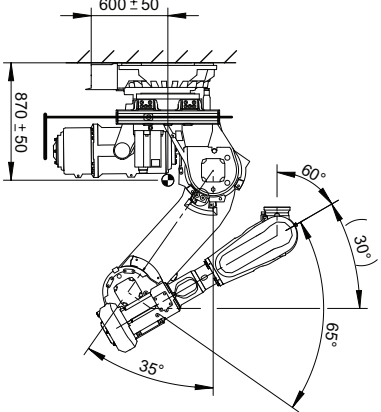

	Action	Note
1	<p> DANGER</p> <p>The robot must always be secured to the foundation if any kind of repair or maintenance work is to be performed.</p> <p>For some repair work support legs are required.</p>	<p>Suitable screws, lightly lubricated: M24x100 (min. 4 pcs)</p> <p>For hole configuration, see Hole configuration, base on page 66.</p>
2	<p>Verify that the lower arm is secured with the transportation lock screw.</p>	
3	<p>Remove any payload and tools from the robot.</p>	<p>DressPack can stay fitted.</p>
4	<p>Jog the robot into position:</p> <ul style="list-style-type: none"> • Axis 1: 0° • Axis 2: already in position and locked with the transportation lock screw, do not jog! • Axis 3: +65° • Axis 4: 0° • Axis 5: +60° • Axis 6: no significance 	 <p>xx1700000555</p>

Continues on next page



4 Repair

4.5.5 Replacing the lower arm

Continued

	Action	Note
5	 DANGER Turn off all: <ul style="list-style-type: none">• electric power supply• hydraulic pressure supply• air pressure supply to the robot, before entering the safeguarded space.	
6	Disconnect the robot cables at the base.	
7	 CAUTION The weight of the IRB 6700Inv / IRB 6700I robot is 1,750 kg All lifting accessories used must be sized accordingly.	
8	Install the fork lift pockets to the robot.  DANGER Handling the tool incorrectly will cause serious injury. Read and follow enclosed user instructions for the tool.	See user instructions enclosed with the fork lift accessory set. Fork lift accessory set: 3HAC058825-001.

Continues on next page

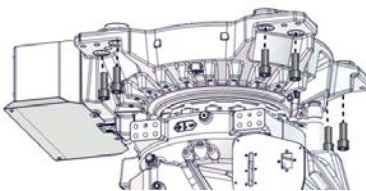
	Action	Note
9	<p>Choose one of the following lifting methods:</p> <ul style="list-style-type: none"> Lifting and turning with the fork lift (rotator attachment required): <ol style="list-style-type: none"> 1 Insert the forks of the fork lift truck into the fork lift pockets, as far as possible. 2 Raise the forks of the fork lift truck to make sure that the weight of the robot rests on the forks. <p> Tip</p> <p>Two M16 screws can be fitted to the fork lift pockets, to press the forks against the pockets and make the lift more stable.</p> Lifting and turning with the turning tool and overhead crane: <ol style="list-style-type: none"> 1 Install and use the turning tool according to enclosed user instructions. <p> DANGER</p> <p>Handling the tool incorrectly will cause serious injury. Read and follow enclosed user instructions for the tool.</p> 	<p>See user instructions enclosed with the turning tool. Turning tool: 3HAC073537-001.</p>
10	<p>Remove the bolts that secure the robot to the foundation.</p>	<p>Quantity: 8 pcs.</p>  <p>xx1600002098</p>
11	<p>Rotate the robot to floor standing position.</p>	<p>Follow the user instructions enclosed with the turning tool.</p>
12	<p>Lower and secure the robot to the floor. (Or to support legs, if replacing the axis-1 gear-box.) The lifting accessories can be kept installed if they are not in the way for the upcoming service procedure.</p>	<p>Attachment screws: M24x100 (min. 4 pcs required to perform service)</p>

Unloading the balancing device



	Action	Note
1	<p>Verify that the robot is secured to the foundation.</p>	<p>Attachment screws: M24x100 (8 pcs).</p>

Continues on next page



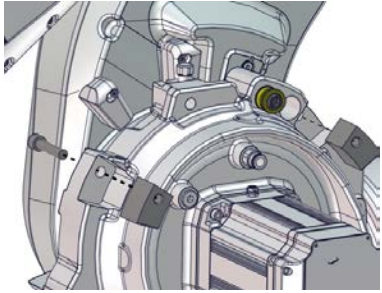
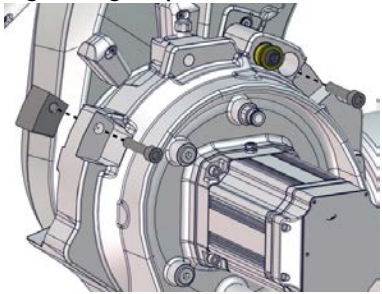

4 Repair

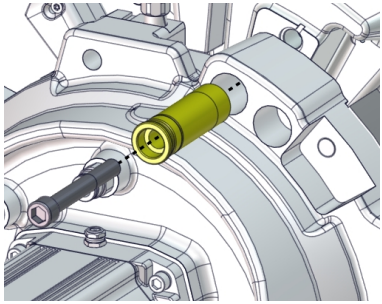
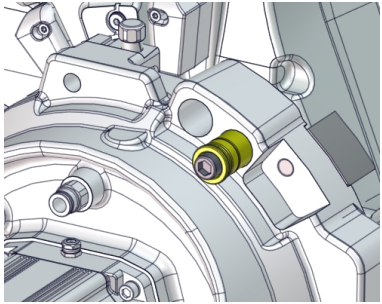
4.5.5 Replacing the lower arm

Continued

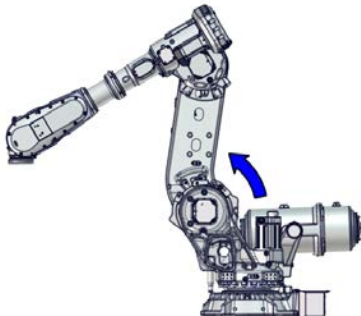
	Action	Note
2	Remove the two service stops from their parking position.	 xx170000067
3	Fit the service stops in maintenance position.	Tightening torque: 70 Nm \pm 15 Nm.  xx170000068
4	Remove the transportation lock screw and yellow sleeve from locking position.  Note It is only allowed to remove the transportation lock screw and sleeve, if the service stops are in maintenance position, when the robot is floor standing.	 xx1700000347
5	Fit the transportation lock screw and the yellow sleeve in their parking position.	 xx1700000348

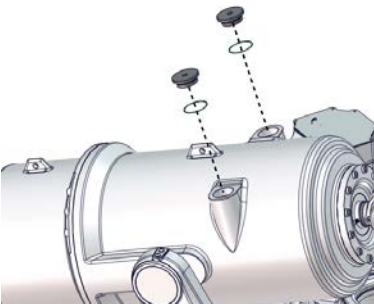
Continues on next page

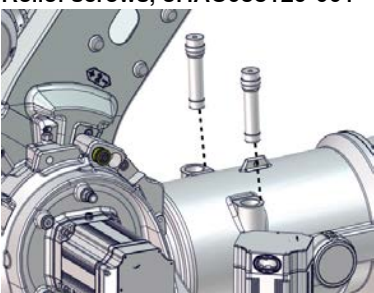
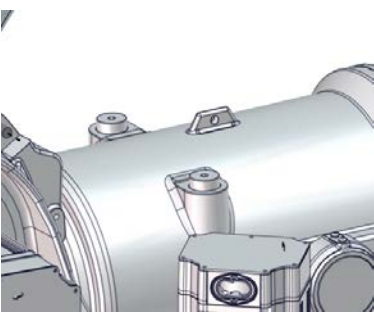

	Action	Note
6	<p>Jog axis 2 to -4° to be able to insert the relief screws.</p>	 <p>xx1700001404</p>
7	<p>Remove the covers on the balancing device.</p> <p> Note</p> <p>The covers have to be refitted after repair or maintenance.</p>	 <p>xx1700000451</p>
8	<p>Fit the relief screws to unload the balancing device.</p> <p> DANGER</p> <p>Do not remove the relief screws when the balancing device is removed from the robot.</p>	<p>Tightening torque: $70 \text{ Nm} \pm 15 \text{ Nm}$ Relief screws, 3HAC058129-001</p>  <p>xx1700000070</p>  <p>xx1700000560</p>

Continues on next page

4 Repair

4.5.5 Replacing the lower arm

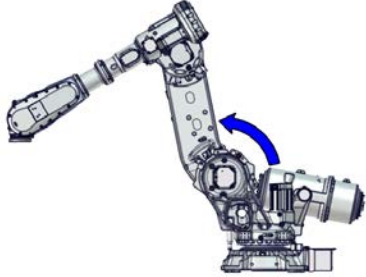
Continued



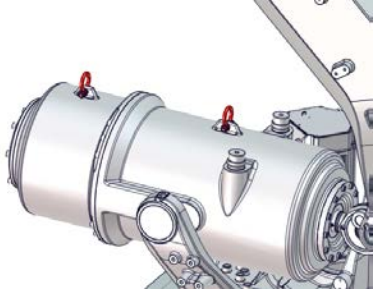

	Action	Note
9	Jog axis 2 to +15°.	 xx1700001405
10	 DANGER Turn off all: <ul style="list-style-type: none"> • electric power supply • hydraulic pressure supply • air pressure supply to the robot, before entering the safeguarded space.	

Attaching lifting accessories to the balancing device

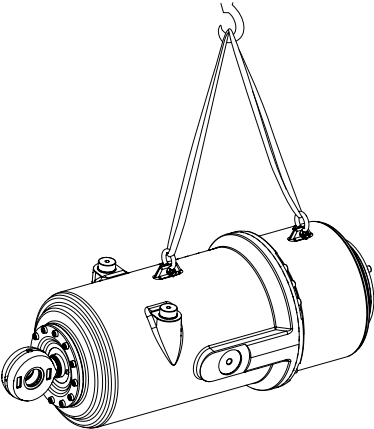

	Action	Note
1	 CAUTION The weight of the balancing device (excluding cradle) is 305 kg All lifting accessories used must be sized accordingly.	
2	Fasten lifting shackles on the balancing device.	SA-10-8-NA1 (2 pcs)  xx1700000086

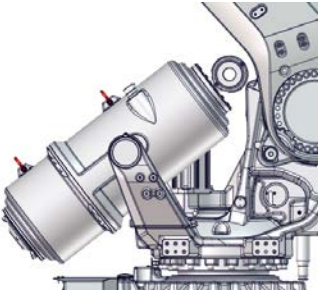
Continues on next page

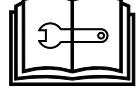
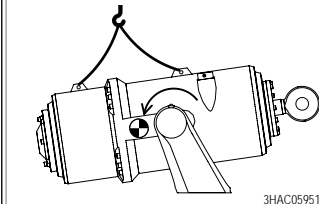
4.5.5 Replacing the lower arm
Continued

	Action	Note
3	Fasten the lifting slings.	Roundsling, 1 m (2 pcs) Lifting capacity: 1,000 kg.  xx170000087
4	Raise the lifting slings to take the weight of the balancing device.  CAUTION The balancing device is heavy at the back, and will tip over when the link ear is loosened.  xx1700000322	   3HAC059516-001 (2) xx1600002060

Removing the shaft in the front (link ear)

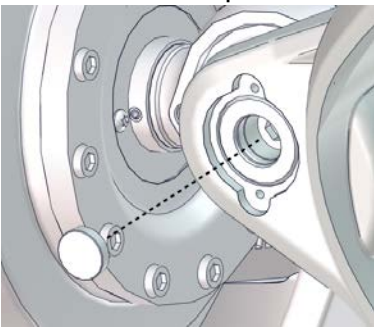
	Action	Note
1	Remove the VK cover at the link ear.  Note Make sure that the lifting accessories hold the weight of the balancing device.  Tip Use high pressure air to remove the VK covers.	It is possible to drive a screwdriver (or similar) through the VK cover, as close as possible to the center of the VK cover and pull it out.  xx1700000088

Continues on next page

4 Repair

4.5.5 Replacing the lower arm

Continued

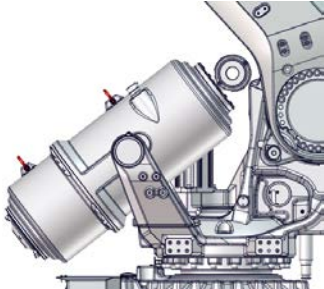
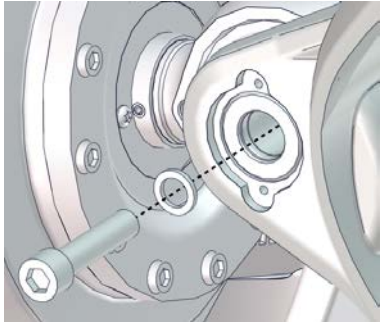
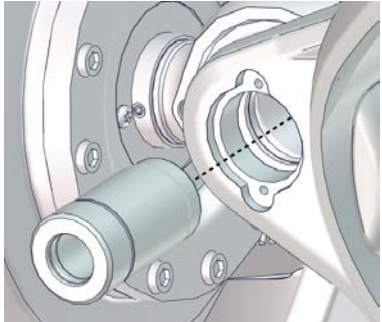
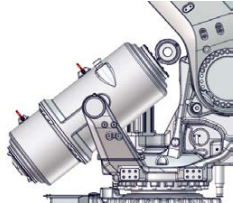
	Action	Note
2	<p>Remove the attachment screw and washer at the link ear.</p> <p> CAUTION</p> <p>The balancing device is heavy at the back, and will tip over when the link ear is loosened.</p>  <p>xx1700000322</p>	 <p>xx1700000089</p>
3	<p>Use the dismantle and mounting tool and pull the shaft out.</p>	<p>Dismantle and mounting tool set: 3HAC028920-001 Press Tool M</p>  <p>xx1700000090</p>
4	<p>Carefully lower the lifting device to let the balancing device rest on the frame.</p>	 <p>xx1700000322</p>

Positioning the robot

	Action	Note
1	<p>Turn the power on temporarily and jog axis 3 so that the upper arm is horizontal. Jog axis 5 to +90°.</p>	<p>The upper arm needs to be in a horizontal position later on, when the arm is lifted away from the robot.</p>

Continues on next page

	Action	Note
2	 DANGER Turn off all: <ul style="list-style-type: none"> • electric power supply • hydraulic pressure supply • air pressure supply to the robot, before entering the safeguarded space.	

Retrieving access to the wrist cabling

Use this procedure to remove the wrist cover to retrieve access to the axis-5 and axis-6 motor cables.

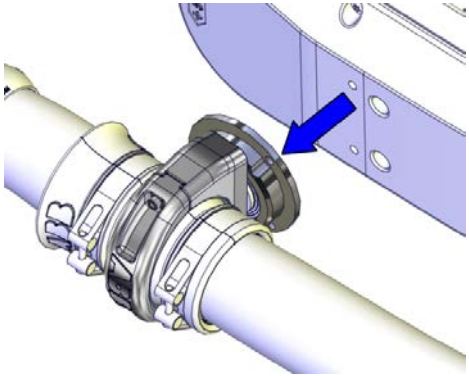
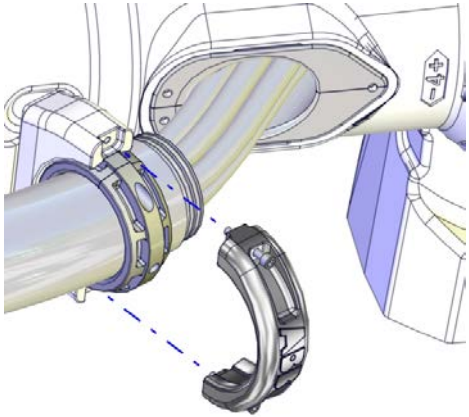

	Action	Note
1	 DANGER Make sure that all supplies for electrical power, hydraulic pressure, and air pressure are turned off.	
2	If DressPack is installed: <ul style="list-style-type: none"> • Remove the bracket with the complete ball joint housing still fitted, as shown in the figure. This is done to be able to reach the two hidden screws that secure the wrist cover.	 <small>xx140000355</small>
3	If used, open the ball joint housing on the arm tube and remove the DressPack cable package.	 <small>xx140000206</small>

Continues on next page

4 Repair

4.5.5 Replacing the lower arm

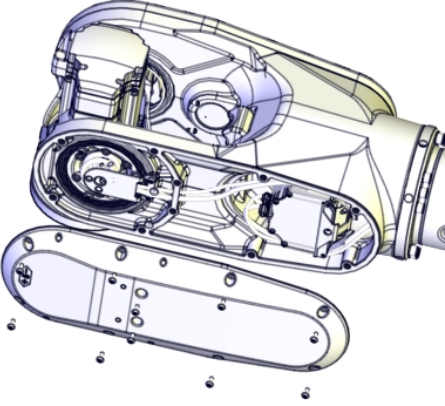
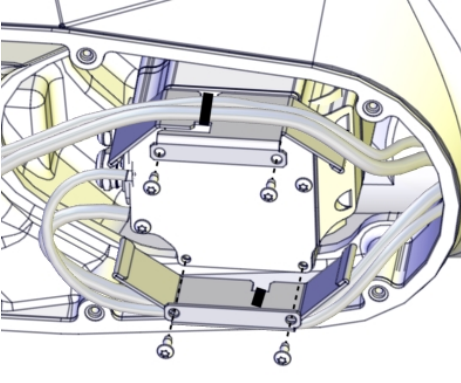
Continued

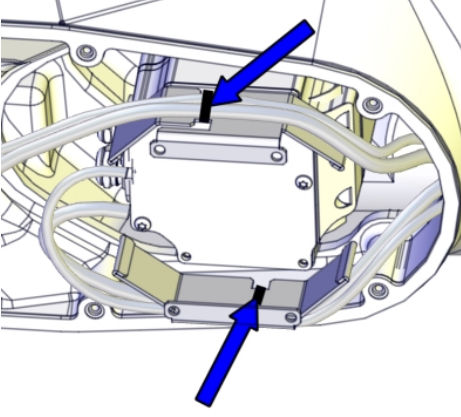
	Action	Note
4	Remove the wrist cover.	 xx1300002247
5	Remove the heat protection plates from the motor with the cabling still attached to the plate.	 xx1500001030
6	<p>Cut the cable ties that hold the cable harness to the plate.</p> <p> Note Keep the heat protection plate until refitting.</p> <p> Tip If removing the plate only for replacing the motor, the cabling does not need to be loosened from the plate.</p>	 xx1500001029

Continues on next page

Removing cable brackets

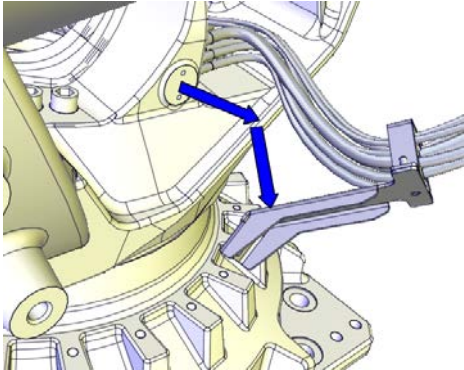
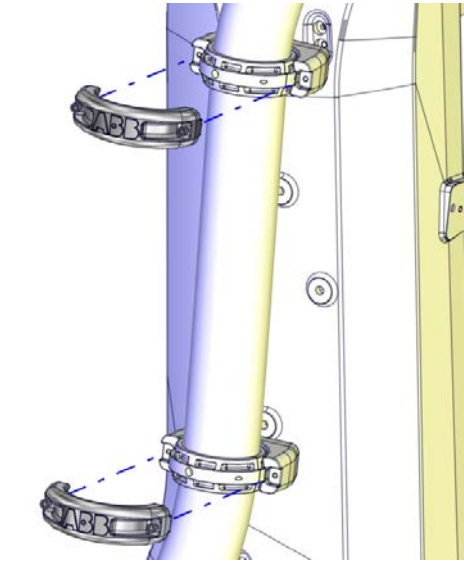
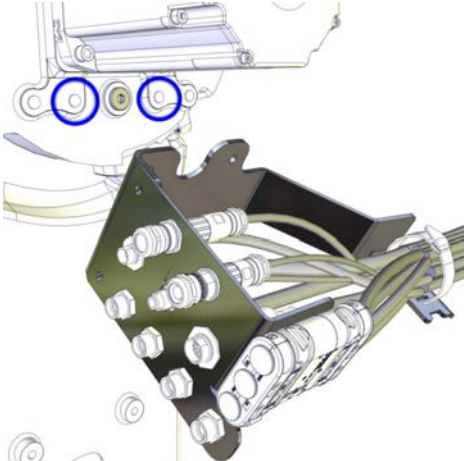
	Action	Note
1	Unscrew the screws that hold the bracket and let it hang free.	 <p>xx1200001184</p>
2	If used, open the ball joint housings on the lower arm and remove the DressPack.	 <p>xx1400001195</p>
3	If used, unscrew the screws that hold the connection plate and let the DressPack hang free.	 <p>xx1200001332</p>

Continues on next page

4 Repair

4.5.5 Replacing the lower arm

Continued

Disconnecting the axis-3 and axis-4 motor cables

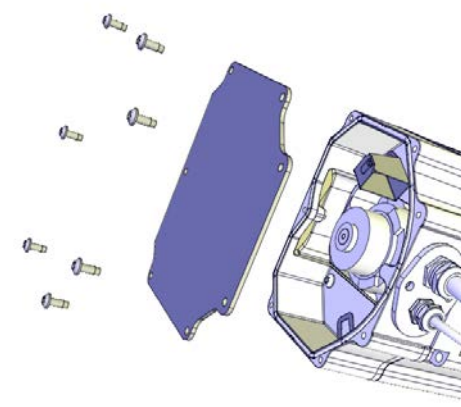
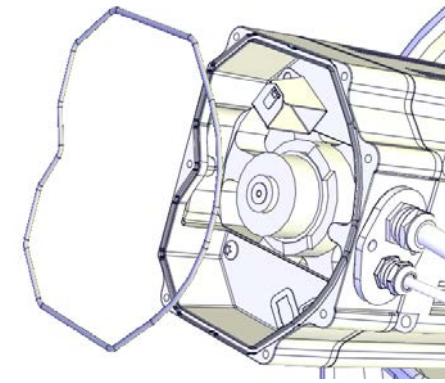
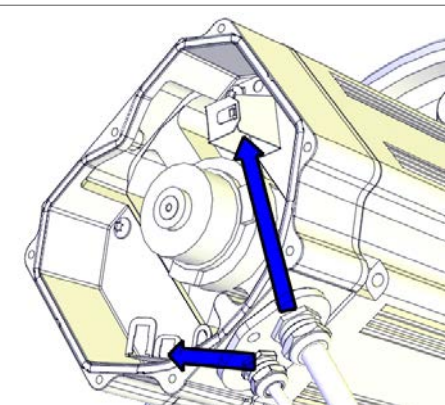
	Action	Note
1	 DANGER Make sure that all supplies for electrical power, hydraulic pressure, and air pressure are turned off.	
2	Unscrew the attachment screws and washers and remove the motor cover.	 xx1200001135
3	Make sure the o-ring is present.	 xx1200001070
4	Disconnect the motor cables.	 xx1200001066

Continues on next page

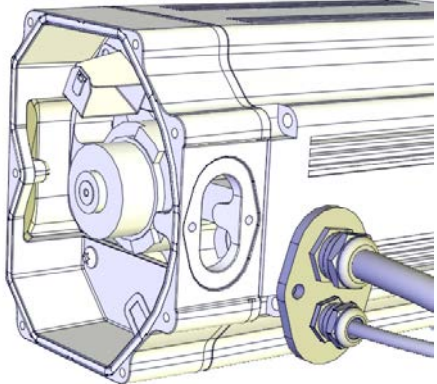
	Action	Note
5	<p>Remove the cable gland cover. Make sure the gasket is not damaged.</p> <p> Tip</p> <p>Make a note in which direction the cable gland hole is facing, if the motor will be removed too. The motor shall be refitted in the same position.</p>	 <p>xx1200001067</p>
6	Use caution and pull out the motor cables.	

Disconnecting the axis-5 motor cables

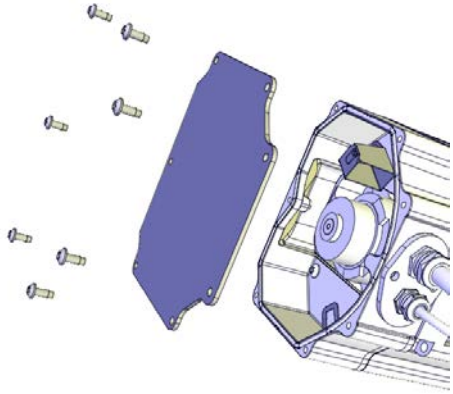

	Action	Note
1	<p> DANGER</p> <p>Make sure that all supplies for electrical power, hydraulic pressure, and air pressure are turned off.</p>	
2	Unscrew the attachment screws and washers and remove the motor cover.	 <p>xx1200001135</p>

Continues on next page

4 Repair

4.5.5 Replacing the lower arm

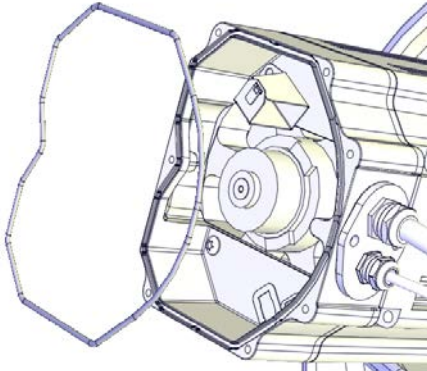
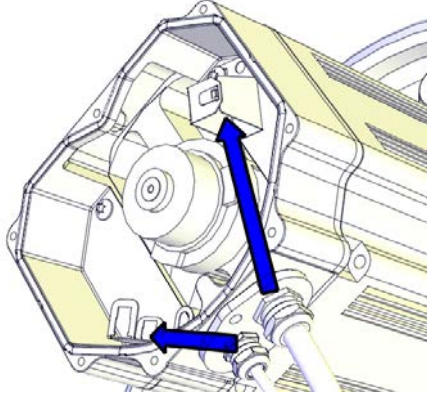
Continued

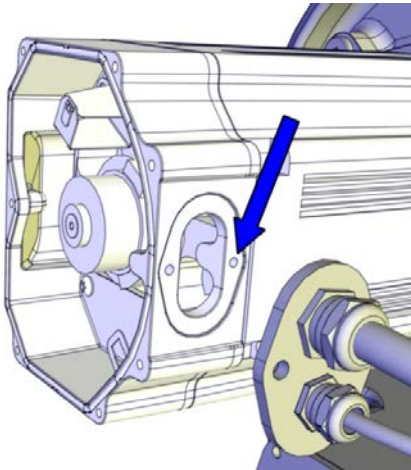
	Action	Note
3	Make sure the o-ring is present.	 xx1200001070
4	Disconnect the motor cables.	 xx1200001066
5	<p>Remove the cable gland cover by performing the following steps:</p> <ol style="list-style-type: none">1 Open the inner screw a little (the one the arrow is pointing at). No need to remove this screw from the motor.2 Remove the outer screw.3 Slide the cable gland cover away from the inner screw. Make sure the gasket is not damaged. <p> Tip</p> <p>Make a note in which direction the cable exit hole is facing, if the motor will be removed too. The motor shall be refitted in the same position.</p>	 xx1300000656
6	Use caution and pull out the motor cables.	

Continues on next page

Disconnecting the axis-6 motor cables

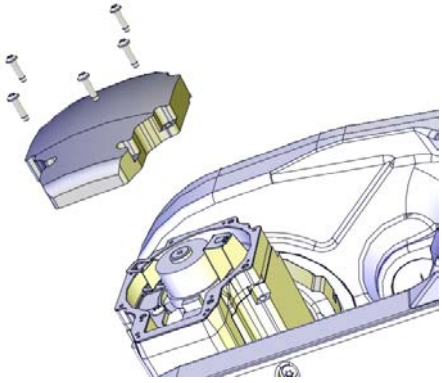
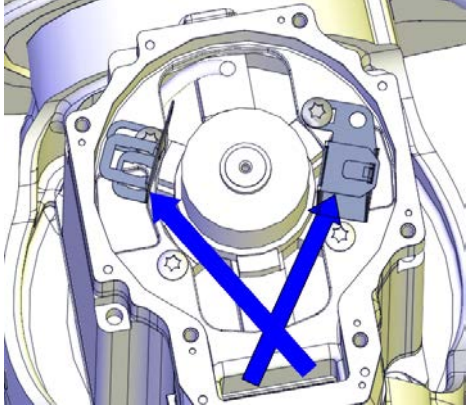
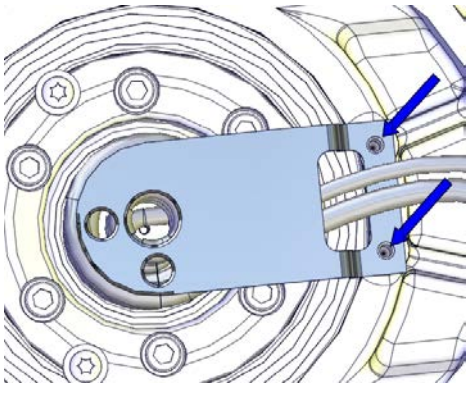
	Action	Note
1	 <p>DANGER</p> <p>Make sure that all supplies for electrical power, hydraulic pressure, and air pressure are turned off.</p>	
2	<p>Unscrew the attachment screws and remove the motor cover.</p>	 <p>xx1200001080</p>
3	<p>Disconnect the motor cables.</p>	 <p>xx1300000488</p>
4	<p>Unscrew the attachment screws that hold the cable bracket.</p>	 <p>xx1300000484</p>

Continues on next page

4 Repair

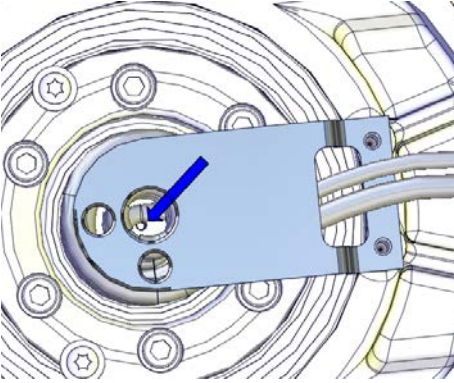
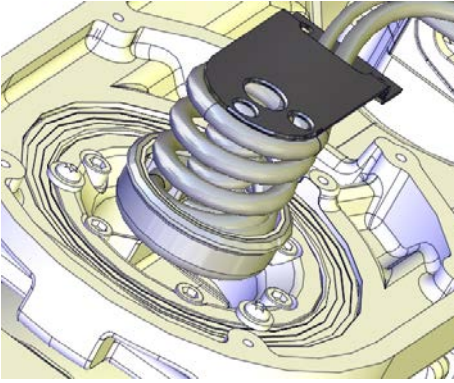
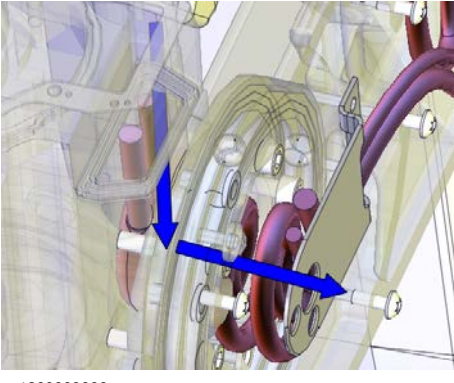

4.5.5 Replacing the lower arm

Continued

	Action	Note
5	<p>Unscrew the M4 screw that holds the carrier.</p> <p> Note</p> <p>The screw is located at the bottom of the carrier.</p>	 <p>xx1300000485</p>
6	<p>Pull out the carrier from its position.</p>	 <p>xx1300001113</p>
7	<p>Pull out the axis-6 motor cables by holding the cables with one hand at the motor and the other at the carrier.</p>	 <p>xx1300000666</p>

Continues on next page

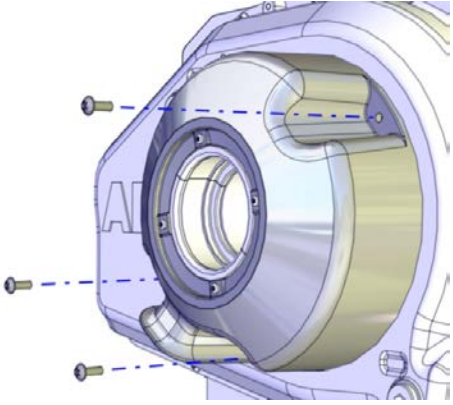
Removing the cable harness - wrist and upper arm

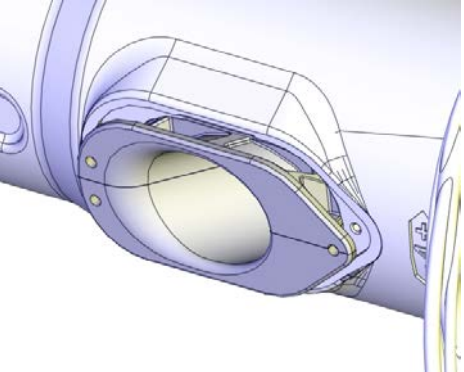

	Action	Note
1	<p>Remove the cover.</p> <p> Note</p> <p><i>Foundry Plus:</i> Use caution not to damage the gasket, not to loose the washers on the cover sealing or not to loose the inserts fitted on the cover.</p>	 <p>xx120000045</p>
2	<p>If the cabling is to be replaced by a new cable harness, remove the cover insert to use it on the new cabling.</p>	 <p>xx1700001803</p>
3	<p>If used, loosen the insert.</p>	 <p>xx1700000690</p>

Continues on next page

4 Repair

4.5.5 Replacing the lower arm

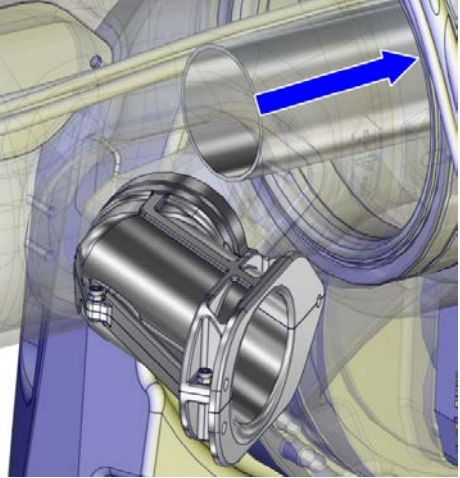
Continued

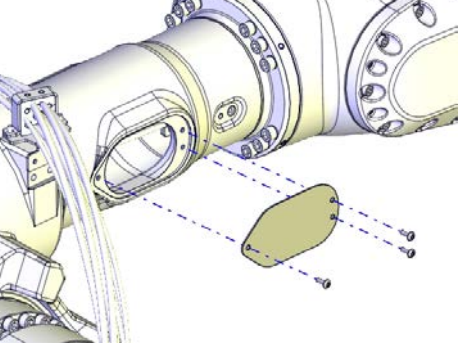
	Action	Note
4	If used, push the DressPack tube a little backwards.	 <p>xx140000720</p>
5	 Tip Use tape and tie the axis-5 and axis-6 connectors and carrier into a bundle (if not already done). This is done to facilitate the removal and to avoid damaging the parts. This will also make it easier to run the cable harness through the inside of the upper arm.	 <p>xx130000668</p>
6	Remove the side cover on the arm tube.	 <p>xx130000557</p>

Continues on next page

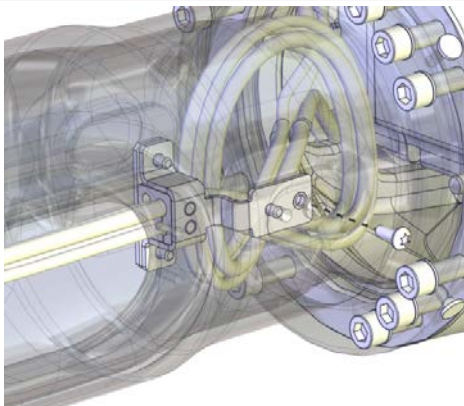
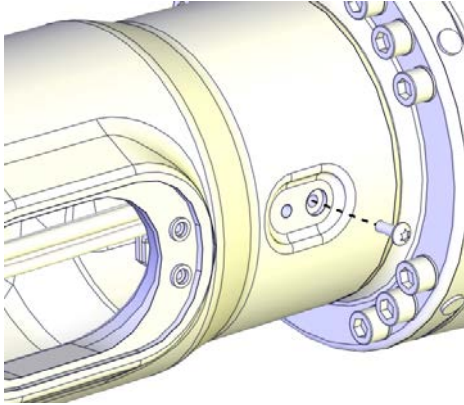
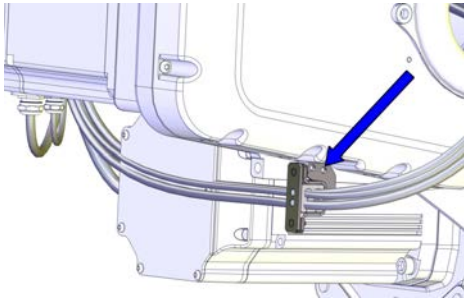
	Action	Note
7	<p>Unscrew the attachment screw that secures the axis-4 metal clamp inside the arm tube.</p> <p> Note</p> <p>The screw is reached from outside the upper arm.</p>	 <p>xx170000340</p>  <p>xx170000339</p>
8	<p>Remove the arm house metal clamp.</p>	 <p>xx130000543</p>

Continues on next page



4 Repair

4.5.5 Replacing the lower arm

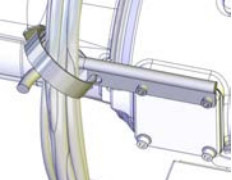
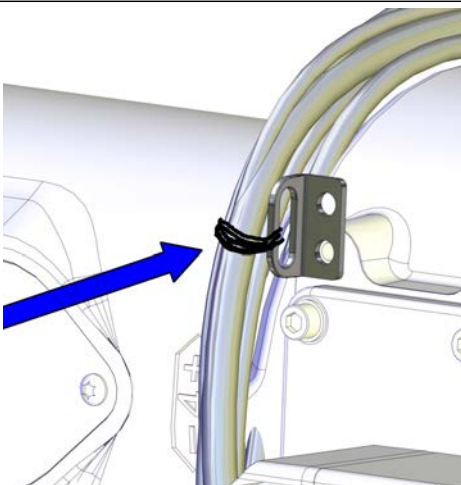
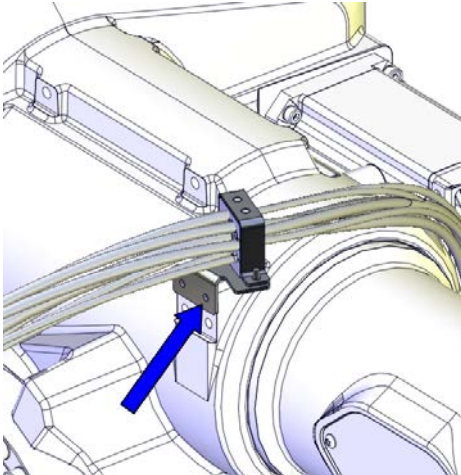
Continued

	Action	Note
9	<p>Cut the cable tie at the cable fixing bracket.</p> <p> Note</p> <p>If DressPack is fitted, the cable fixing bracket is replaced by the cable guide.</p>  <p>xx1300001973</p> <p>Cable guide.</p>	 <p>xx1300000544</p> <p>Cable fixing bracket.</p>
10	<p>Remove the metal clamp on top of the arm house.</p>	 <p>xx1300000541</p>

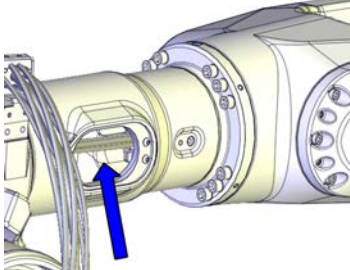
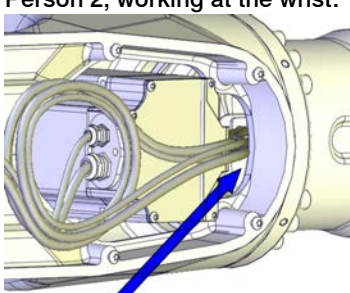
Continues on next page

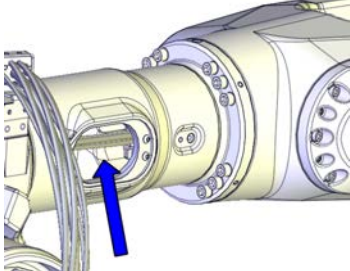
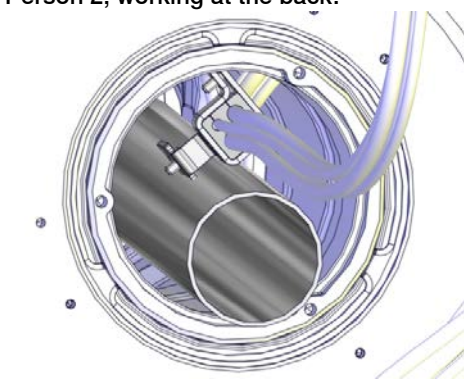
	Action	Note
11	<p>Remove the cable harness out from the wrist.</p> <p> Tip</p> <p>This step is best performed by two persons working together:</p> <ul style="list-style-type: none"> • Person 1: Put one hand inside the side hole and take a hold of the cable harness. • Person 2: Take a hold on the cable harness inside the wrist. • Together: Move the cable harness past the axis-5 motor and into the arm tube. 	<p>Person 1, working at the side hole:</p>  <p>xx130000745</p> <p>Person 2, working at the wrist:</p>  <p>xx130000746</p>
12	<p>Remove the cable harness out of the arm tube, at the back of the upper arm.</p> <p> Tip</p> <p>This step is best performed by two persons working together:</p> <ul style="list-style-type: none"> • Person 1: Put one hand inside the side hole and take a hold of the cable harness. • Person 2: Take a hold on the cable harness at the back of the robot. • Together: Move the cable harness out of the arm tube. 	<p>Person 1, working at side hole:</p>  <p>xx130000745</p> <p>Person 2, working at the back:</p>  <p>xx140002561</p>

Continues on next page





4 Repair

4.5.5 Replacing the lower arm

Continued

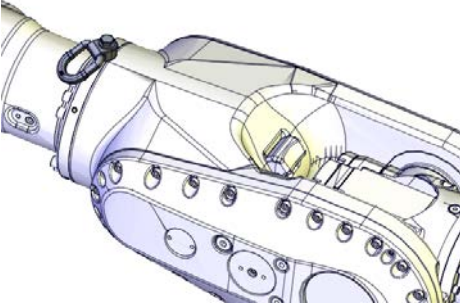
Attaching the lifting accessories to the upper arm

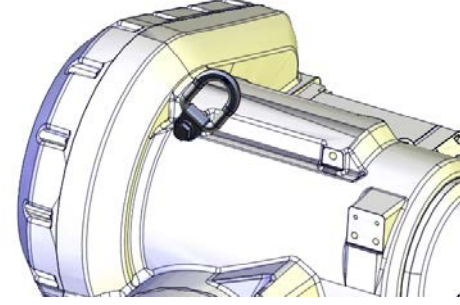

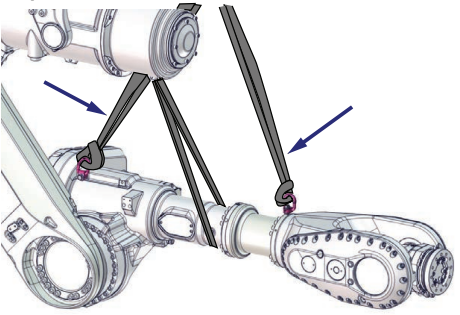
Use this procedure to attach the lifting accessories to the upper arm.

	Action	Note
1	 CAUTION The weight of the complete upper arm (including the wrist) is 465 kg All lifting accessories used must be sized accordingly.	
2	Fit a lifting eye to the wrist.	Lifting eye, M12: 3HAC16131-1  <small>xx1200001133</small>
3	Fit a lifting eye in the arm house, with a fender washer underneath.  <small>xx1400002196</small>	Lifting eye, M12: 3HAC16131-1 Fender washer: Outer diameter: minimum 26 mm, maximum 30 mm, hole diameter: 13 mm, thickness: 3 mm.  <small>xx1200001134</small>
4	Attach a lifting sling to an overhead crane (or similar) and then to the lifting eye in the arm house.	Roundsling, 2 m: Lifting capacity: 2,000 kg. (2 pcs)
5	Attach a lifting sling to an overhead crane (or similar) and then to the lifting eye in the wrist.  Note Lifting slings are used instead of lifting chains to not damage the balancing device surface.	 <small>xx1700000693</small>
6	Raise the lifting accessories to take the weight of the upper arm.	

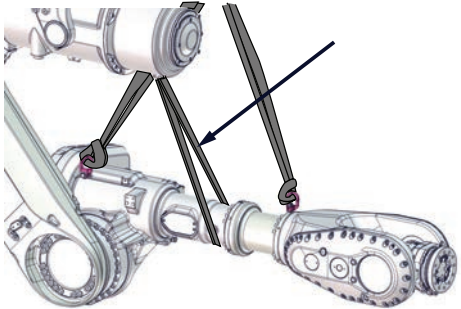
Continues on next page

	Action	Note
7	Remove the lifting sling between the upper arm and the balancing device.	 <p>xx180000047</p>

Preparations before removing the upper arm

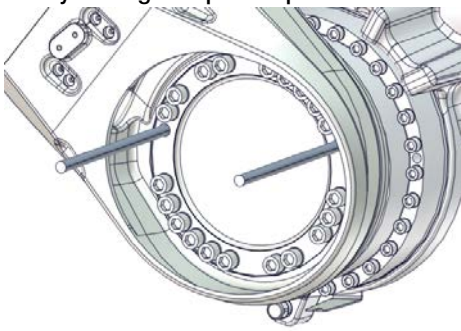
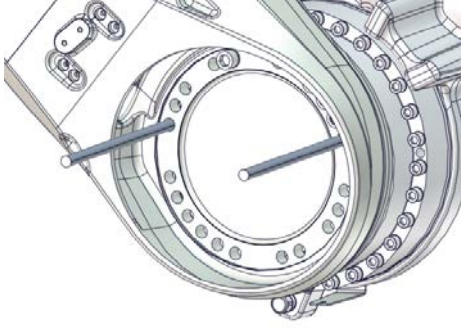
	Action	Note
1	<p>Remove two attachment screws in opposite holes and replace them with guide pins.</p> <p> Note</p> <p>Make sure that it is the screws that hold the lower arm to the axis-3 gearbox that are removed!</p> <p> Tip</p> <p>Lubricate the guide pins with some grease to make the upper arm slide better.</p>	<p>Guide pin, M16x150: 3HAC13120-2 Guide pin, M16x200: 3HAC13120-3 Always use guide pins in pairs.</p>  <p>xx1700000457</p>
2	<p>Leave one of the remaining attachment screws fitted, remove the other screws.</p>	 <p>xx1700000458</p>

Continues on next page

4 Repair

4.5.5 Replacing the lower arm

Continued

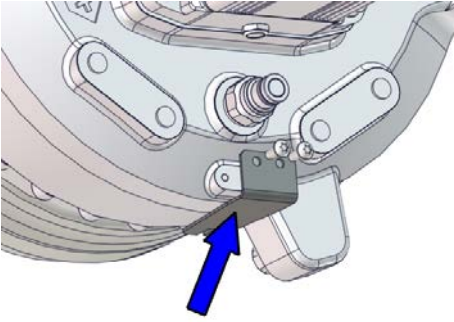
	Action	Note
3	Remove the axis-3 synchronization mark plate.	 xx170000694

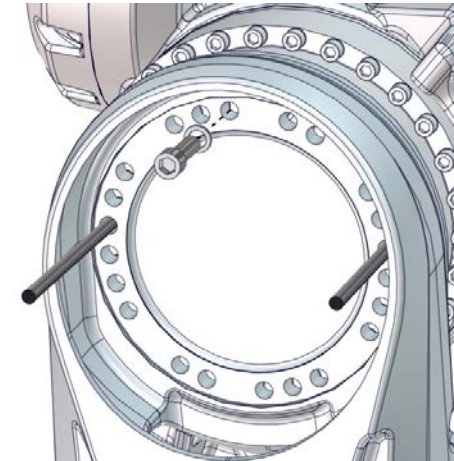
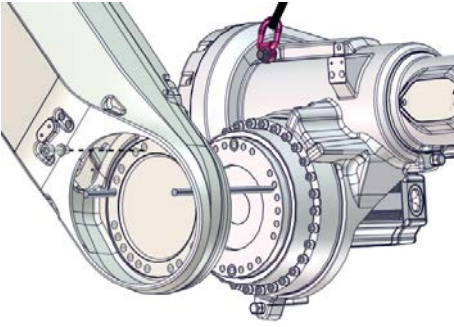

Removing the upper arm

	Action	Note
1	Remove the remaining attachment screw and let the upper arm slide out from the lower arm with support from the guide pins.	 xx170000059  xx170000459
2	Lift the upper arm and place it on the prepared area.	

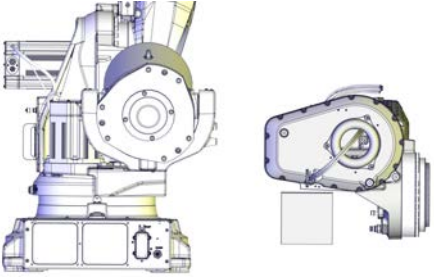
Continues on next page

	Action	Note
3	<p><i>This step is only valid when the upper arm is removed due to replacement of the axis-3 gearbox:</i></p> <p>Place pieces of wood (or similar) under arm house and wrist. Lower the upper arm, and let the upper arm rest as shown in the figure.</p> <p>This is done in order to keep the axis-3 gearbox in a vertical position and to get the best position to replace the axis-3 gearbox, if applicable.</p>	 <p>xx1300000553</p>

Preparations before removing the lower arm

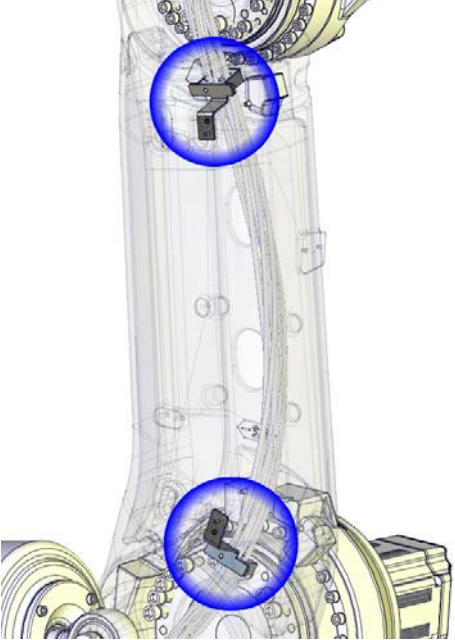

	Action	Note
1	 <p>DANGER</p> <p>Make sure that all supplies for electrical power, hydraulic pressure, and air pressure are turned off.</p>	
2	<p>Open the ball joint housings on the lower arm and remove the DressPack.</p>	
3	<p>Loosen the axis-2 lower arm metal clamp and the axis-3 lower arm metal clamp located on the inside of the lower arm by removing the attachment screws.</p>  <p>Note</p> <p>The screws are reached from outside the lower arm!</p>	 <p>xx1300000540</p>

Continues on next page

4 Repair

4.5.5 Replacing the lower arm

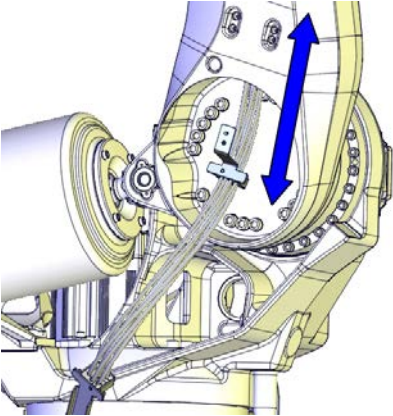
Continued

	Action	Note
4	Remove the cable harness from inside the lower arm.	 <p>xx130000733</p>
5	 CAUTION The lower arm weighs 160 kg All lifting accessories used must be sized accordingly!	
6	Apply the lifting accessory to the lower arm.	

Removing the lower arm

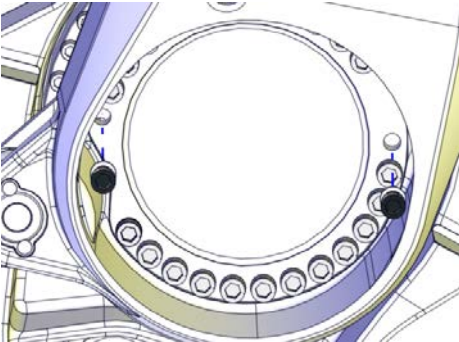
	Action	Note
1	Raise the lifting accessory to unload the lower arm.	
2	Remove two attachment screws in opposite holes and replace them with guide pins.  Tip Lubricate the guide pins with some grease to make the lower arm slide better.	Guide pin, M16x150: 3HAC13120-2 Guide pin, M16x200: 3HAC13120-3 Always use guide pins in pairs.  <p>xx1400002181</p>

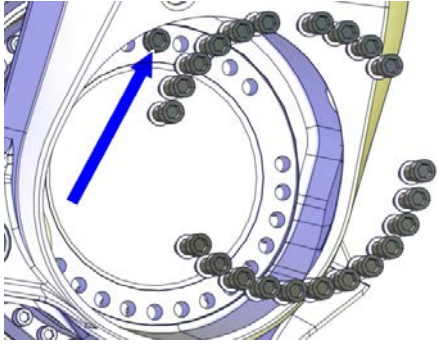

Continues on next page

	Action	Note
3	Remove all but one of the remaining attachment screws that secure the lower arm to the axis-2 gearbox.	 <p>xx1400002182</p>
4	Make sure the lifting accessory is holding the weight of the arm system.	
5	Remove the remaining screw, slide the lower arm out on the guide pins and remove the lower arm.	

Refitting the lower arm

Use these procedures to refit the lower arm.

Preparations before refitting the lower arm

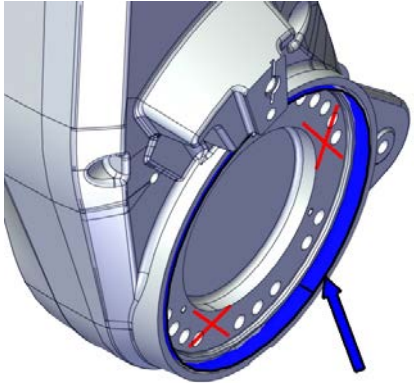

	Action	Note
1	 <p>DANGER</p> <p>Make sure that all supplies for electrical power, hydraulic pressure, and air pressure are turned off.</p>	
2	<p>Apply Mercasol on the surface on the lower arm as shown in the figure.</p>  <p>CAUTION</p> <p>Keep the sealing surfaces clean from Mercasol.</p>	<p>Rust preventive: 3HAC034903-001 (Mercasol 3110 Waxcoat. Recommended drying time is 24h.).</p>  <p>xx1700001879</p>

Continues on next page

4 Repair

4.5.5 Replacing the lower arm

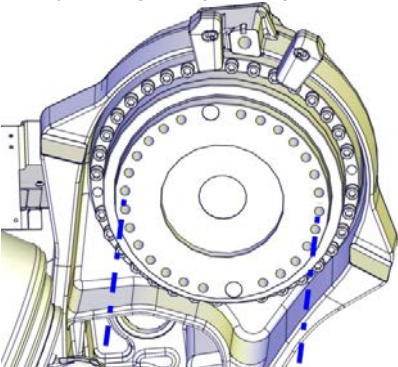
Continued

	Action	Note
3	<p>Fit two guide pins in opposite holes in the axis-2 gearbox.</p> <p> Tip</p> <p>Lubricate the guide pins with some grease to make the lower arm slide better.</p>	<p>Guide pin, M16x150: 3HAC13120-2 Always use guide pins in pairs.</p>  <p>xx1400002189</p>
4	<p> CAUTION</p> <p>The lower arm weighs 160 kg. All lifting accessories used must be sized accordingly.</p>	
5	<p>Attach the lifting accessory to the lower arm.</p>	
6	<p>Wipe clean all contact surfaces.</p>	

Securing the lower arm to the axis-2 gearbox

	Action	Note
1	<p>Lift the lower arm onto the guide pins and slide it into position.</p>	
2	<p>In case the hole pattern of the lower arm and gearbox does not match:</p> <ul style="list-style-type: none"> • Remove the motor cover. • Apply the rotation tool on the motor shaft. • Connect the 24 VDC power supply. • Release the brakes. • Rotate pinion and gear with the rotational tool until the holes matches. <p>Connect 24 VDC the power supply to connector R2.MP2:</p> <ul style="list-style-type: none"> • + = pin 2 • - = pin 5 	<p>Rotation tool 24 VDC power supply</p>  <p>xx1300000819</p>
3	<p>Fit one attachment screw in one of the upper holes using it for security and lower the lifting accessory a little.</p>	

Continues on next page

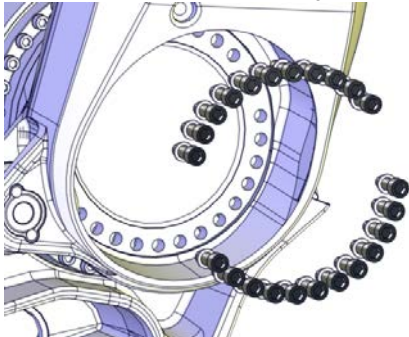
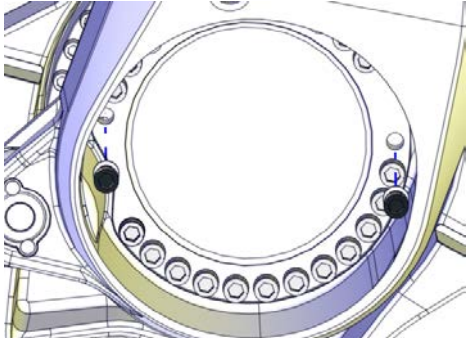
	Action	Note
4	Secure the lower arm by fitting and tightening the accessible screws.	Tightening torque M16: 300 Nm Attachment screws: M16x50 quality steel 12.9 Gleitmo (21 pcs) Washers: steel 17x25x3 (21 pcs)  xx1400002190
5	Disconnect the 24 VDC power supply (if used).	
6	Remove the guide pins and replace them with the remaining attachment screws.	 xx1400002181
7	Secure the remaining attachment screws.	Tightening torque M16: 300 Nm
8	Remove the lifting accessory from the lower arm.	



Preparations before refitting the upper arm

	Action	Note
1	Wipe clean all contact surfaces.	

4 Repair

4.5.5 Replacing the lower arm

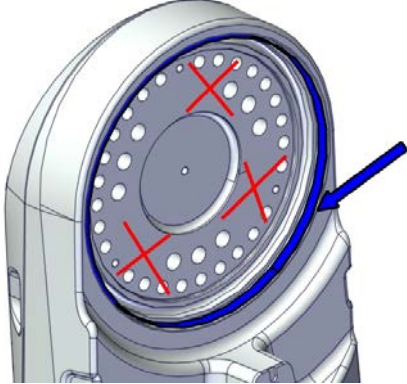
Continued

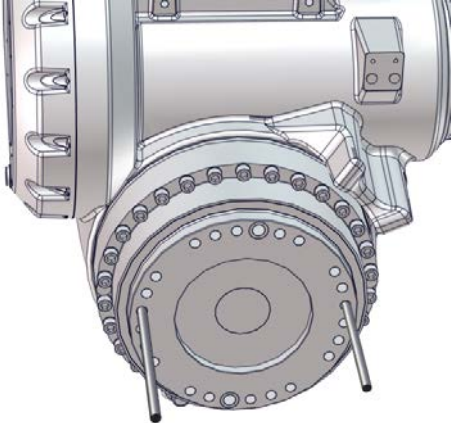
	Action	Note
2	<p><i>Foundry Plus:</i> Apply Mercasol on the surface on the lower arm as shown in the figure.</p> <p> CAUTION</p> <p>Keep the sealing surfaces clean from Mercasol.</p>	<p>Rust preventive: 3HAC034903-001 (Mercasol 3110 Waxcoat. Recommended drying time is 24h.)</p>  <p>xx1700001880</p>
3	<p>Fit two guide pins in opposite M16 holes in the axis-3 gearbox.</p> <p> Tip</p> <p>Lubricate the guide pins with some grease to make the upper arm slide better.</p>	<p>Guide pin, M16x150: 3HAC13120-2 Guide pin, M16x200: 3HAC13120-3 Always use guide pins in pairs.</p>  <p>xx1700000056</p>

Securing the upper arm

	Action	Note
1	<p> CAUTION</p> <p>The weight of the complete upper arm (including the wrist) is 465 kg All lifting accessories used must be sized accordingly.</p>	
2	<p>Attach the lifting accessories, if not already fitted.</p>	<p>See Attaching lifting accessories to the upper arm on page 210.</p>
3	<p>Lift the upper arm and bring it towards the lower arm.</p>	

Continues on next page

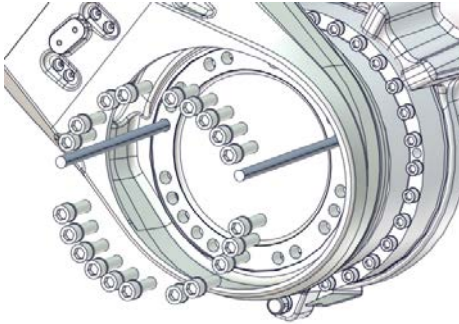
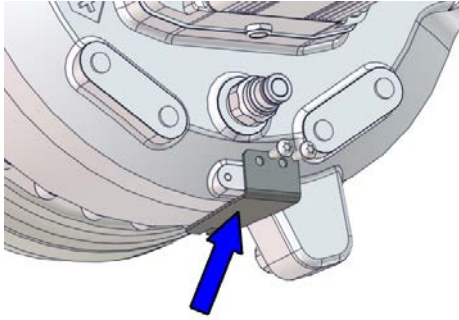
	Action	Note
4	<p>If the axis-3 motor is installed to the upper arm: Connect the 24 VDC power supply, to release the brakes. Connect to R2.MP3-connector:</p> <ul style="list-style-type: none"> • + = pin 2 • - = pin 5 <p>Use the rotation tool and rotate the axis-3 motor to find the correct position for the guide pins in the lower arm. Disconnect and remove the 24 VDC power supply after finding the position.</p>	<p>24 VDC power supply Rotation tool</p>
5	<p>If the axis-3 motor is not installed to the upper arm: Use the pinion to rotate the axis-3 gearbox to find the correct position for the guide pins in the lower arm.</p>	<p>Pinion: 3HAC067545-001</p>
6	<p>Insert and tighten 20 of the 22 M16 screws.</p>	 <p>xx170000460</p>
7	<p>Remove the guide pins and fit the two remaining screws.</p>	
8	<p>Secure the upper arm by tightening the attachment screws.</p>	<p>M16, tightening torque: 300 Nm</p>
9	<p>Refit the axis-3 synchronization mark plate.</p>	 <p>xx170000694</p>





Continues on next page

4 Repair

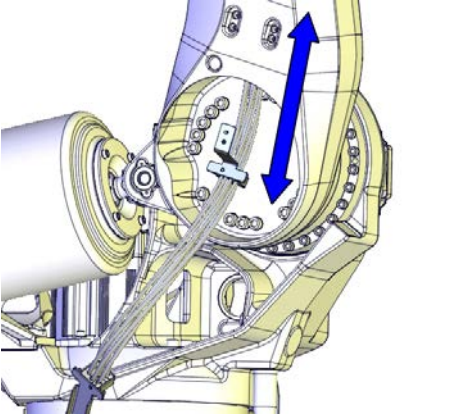

4.5.5 Replacing the lower arm

Continued

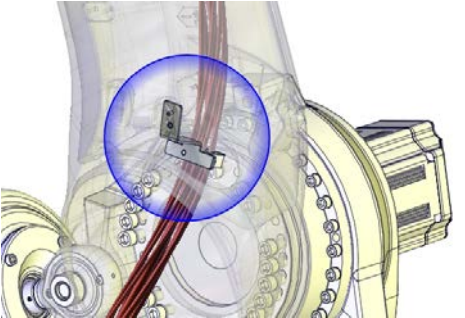
Refitting the cable harness - lower arm

	Action	Note
1	<p> Tip</p> <p>Use tape and tie the axis-5 and axis-6 connectors and carrier into a bundle (if not already done). This is done to facilitate the procedure and to avoid damaging the parts during the procedure.</p> <p>This will also make it easier to run the cable harness through the inside of the robot.</p>	 <p>xx130000668</p>
2	<p>Run the upper end of the cable harness up through the lower arm.</p>	 <p>xx130000733</p>
3	<p>Refit the axis-2 lower arm metal clamp located on the inside of the lower arm.</p> <p> Note</p> <p>The screws are reached from the outside of the lower arm.</p>	 <p>xx130000734</p>

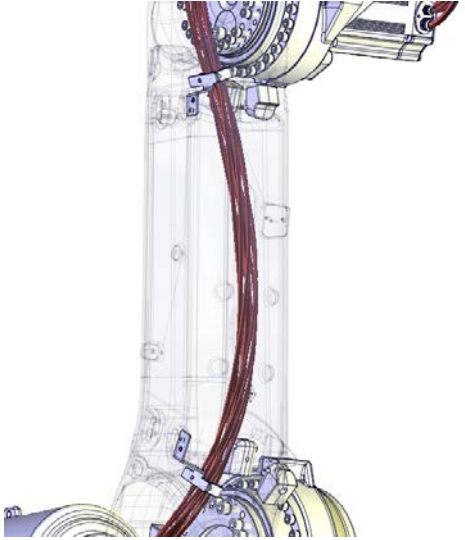
Continues on next page

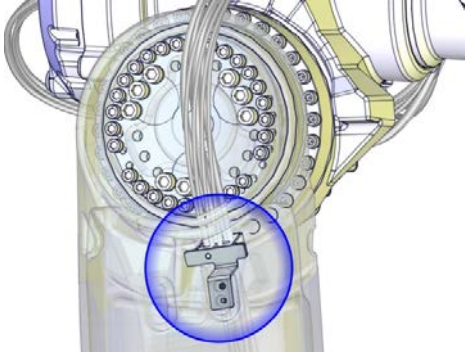
	Action	Note
4	<p>Before fitting the remaining axis-3 lower arm cable bracket inside the lower arm, check that it will stay twisted a little between the metal clamps, after fitting, as shown in the figure. Do not change the position of the brackets!</p>	 <p>xx130000595</p>
5	<p>Refit the axis-3 lower arm metal clamp located on the inside of the lower arm.</p> <p> Note</p> <p>The screws are reached from the outside of the lower arm.</p>	 <p>xx130000558</p>

Refitting the cable harness - upper arm

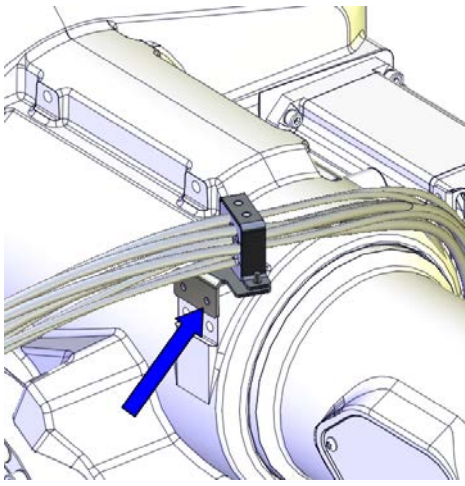

	Action	Note
1	<p>Refit the metal clamp on top of the arm house.</p>	 <p>xx130000541</p>

Continues on next page

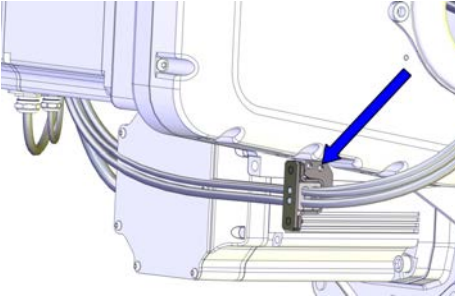

4 Repair

4.5.5 Replacing the lower arm

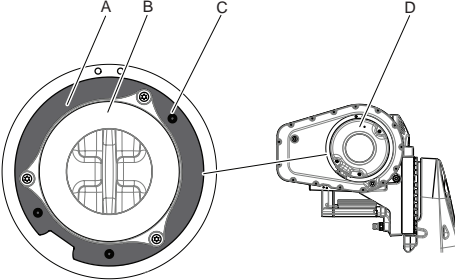
Continued

	Action	Note
2	Refit the arm house metal clamp.	 <p>xx130000543</p>
3	Arrange the cables between the cable clamps in the upper arm.	
4	 Tip Use tape and tie the axis-5 and axis-6 connectors and carrier into a bundle (if not already done). This is done to facilitate the procedure and to avoid damaging the parts during the procedure. This will also make it easier to run the cable harness through the inside of the robot.	 <p>xx130000668</p>
5	Foundry Plus: Make sure that the gasket underneath the cover is correctly fitted. Replace if damaged. The gasket is covered with adhesive on the side facing the upper arm cover. The three washers are pressed into the holes in the gasket. Make sure all three washers are fitted.	 <p>xx140000382</p> <ul style="list-style-type: none">A GasketB Cable guideC WasherD Cover

Continues on next page

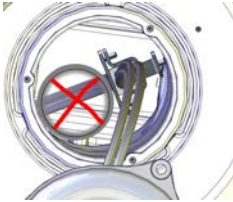
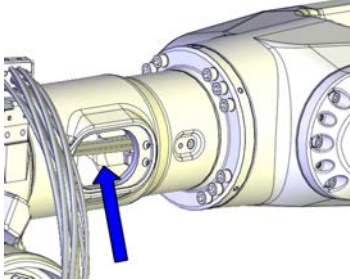
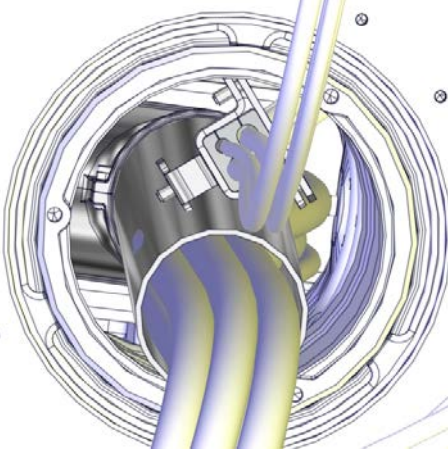

	Action	Note
6	<p>Run the cable harness through the cable guide and then into and through the upper arm tube.</p> <p> Tip</p> <p>This step is best performed by two persons working together:</p> <ul style="list-style-type: none"> • Person 1: Put one hand inside the side hole of the arm tube and take a hold of the cable harness. • Person 2: Take a hold on the cable harness at the back of the robot. • Together: Use caution and move the cable harness into the arm tube. <p> Note</p> <p>The cable harness is best placed at the upper right hand side of the DressPack tube, if used, through the arm tube.</p> <p>Do not run the cable harness into the DressPack tube!</p> <p> Note</p> <p>Do not run the cable harness into the DressPack tube, if one is fitted!</p> <p></p> <p>xx130000820</p>	<p>Person 1, working at the side hole:</p> <p></p> <p>xx130000745</p> <p>Person 2, working at the back:</p> <p></p> <p>xx140000356</p>

Continues on next page

4 Repair

4.5.5 Replacing the lower arm

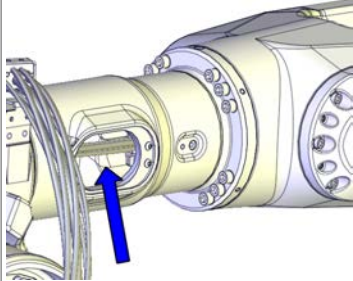
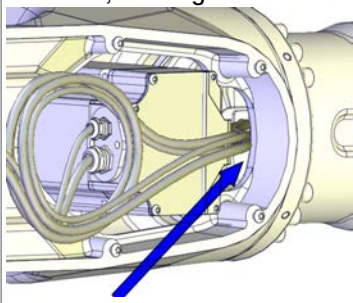
Continued

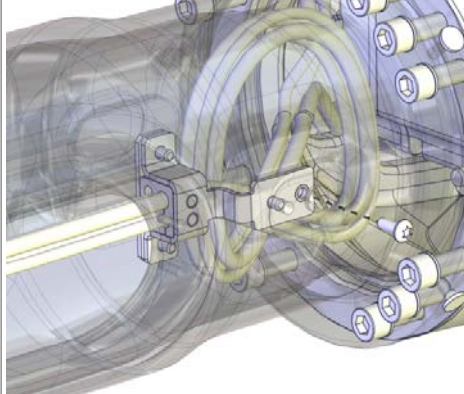
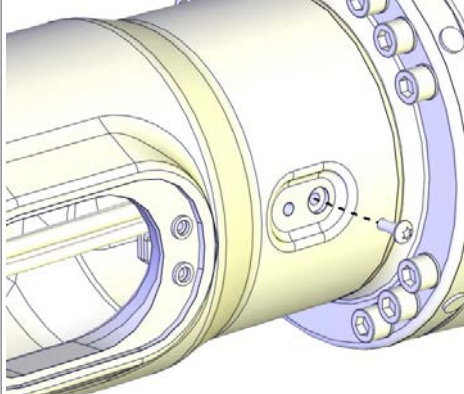
	Action	Note
7	<p>Use caution and push the cable harness into the wrist.</p> <p> Tip</p> <p>This step is best performed by two persons working together:</p> <ul style="list-style-type: none">• Person 1: Put one hand inside the side cover hole and take a hold of the cable harness.• Person 2: Take a hold of the cable harness from inside the wrist.• Together: Move the cable harness past the axis-5 motor and into the wrist.	<p>Person 1, working at the side hole:</p>  <p>xx130000745</p> <p>Person 2, working at the wrist:</p>  <p>xx130000746</p>
8	<p>Refit the metal clamp axis-4, inside the arm tube.</p> <p> Note</p> <p>The screws are reached from outside the upper arm.</p>	 <p>xx170000340</p>  <p>xx170000339</p>

Continues on next page

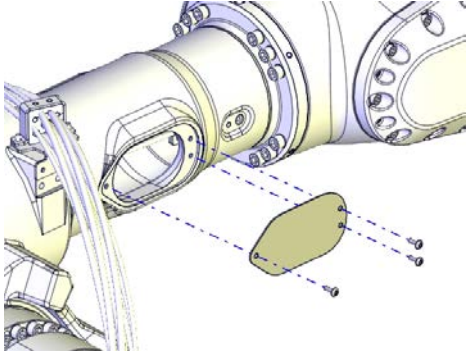
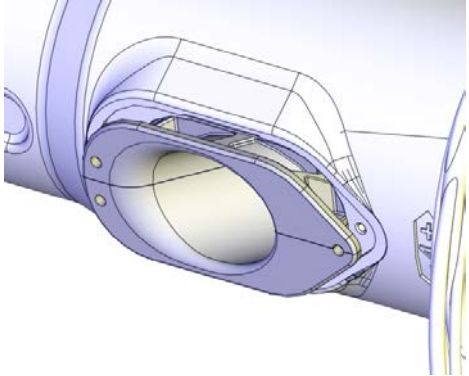
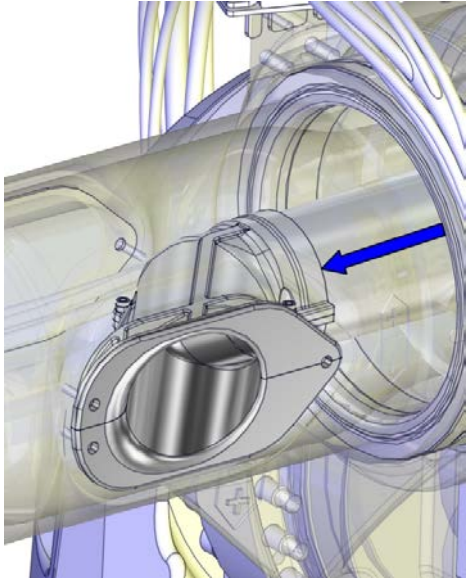

	Action	Note
9	<p>Refit the side cover.</p> <p> Note</p> <p><i>Foundry Plus:</i></p> <ul style="list-style-type: none"> • Make sure the gasket is fitted correctly on the side cover • Use attachment screws made of stainless steel to fit the side cover. 	 <p>xx130000557</p>
10	<p>If used, refit the insert that guides the DressPack cable package through the hole in the upper arm.</p>	 <p>xx170000690</p>
11	<p>If used, refit the tube containing the DressPack into the insert.</p>	 <p>xx140000092</p>

Continues on next page

4 Repair

4.5.5 Replacing the lower arm

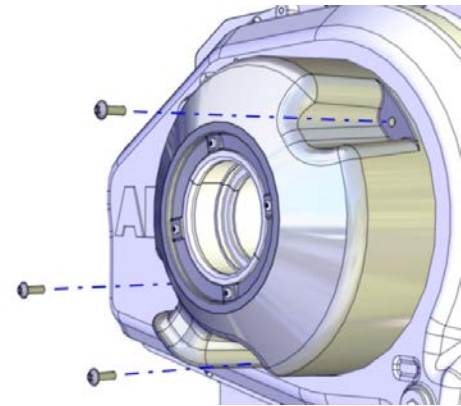

Continued

	Action	Note
12	Fit the cover insert around the new cabling and secure it with a weatherstrip.	<p>Cover insert: 3HAC048520-001.</p>  <p>xx1700001803</p> <p>Weatherstrip: 3HAC053986-001.</p>  <p>xx1700001804</p>
13	<p><i>DressPack or Foundry Plus:</i> Refit the cover with the tube guiding ring fitted.</p> <p> Note</p> <p><i>Foundry Plus:</i></p> <ul style="list-style-type: none">• Make sure the gasket is fitted correctly• Use attachment screws made of stainless steel to fit the cover.	 <p>xx120000045</p>

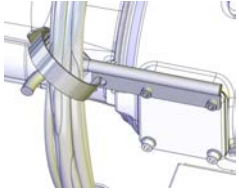
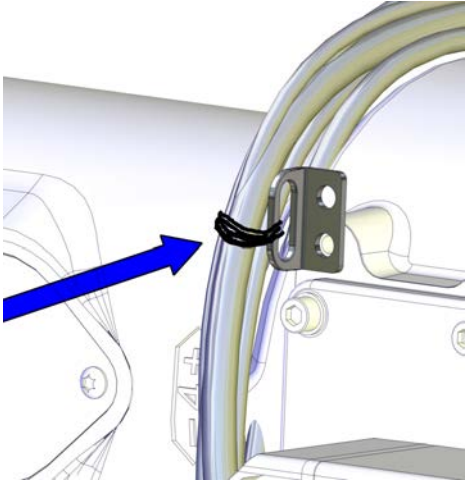
Continues on next page

	Action	Note
14	<p>Secure the cable harness to the cable fixing bracket with a cable tie.</p> <p> Note</p> <p>If DressPack is fitted, the cable fixing bracket is replaced by the cable guide.</p>  <p>xx1300001973</p>	 <p>xx1300000544</p>

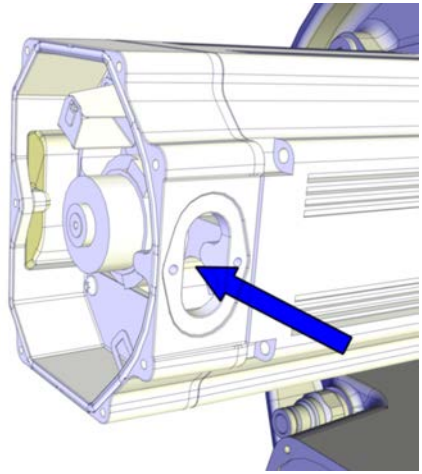
Connecting the axis-3 and axis-4 motor cables

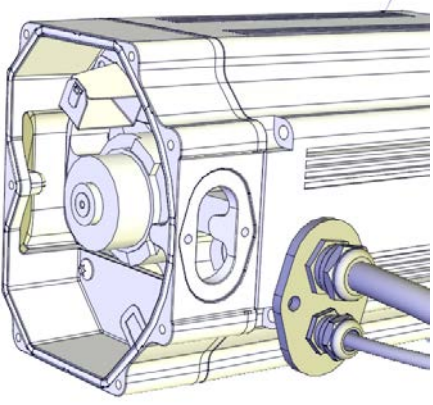



	Action	Note
1	<p>Push the motor cables through the cable gland opening.</p>	 <p>xx1300000738</p>
2	<p>Refit the cable gland cover.</p> <p> Note</p> <p>Replace the gasket if damaged.</p>	 <p>xx1200001067</p>

Continues on next page

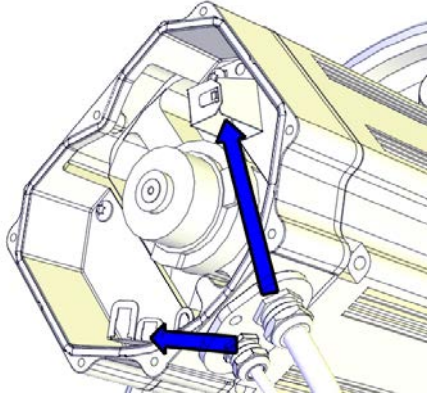

4 Repair

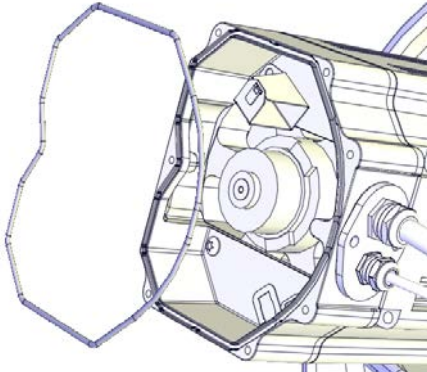
4.5.5 Replacing the lower arm



Continued

	Action	Note
3	<p>Connect the motor cables. Connect in accordance with the markings on the connectors.</p>	 <p>xx1200001066</p>
4	<p>Inspect the o-ring.</p> <p> Note Replace if damaged.</p>	<p>O-ring, axis-1: 3HAC054692-002 O-ring, axis-2: 3HAC054692-002 O-ring, axis-3: 3HAC054692-002 O-ring, axis-4: 3HAC054692-001</p>  <p>xx1200001070</p>
5	<p>Wipe clean o-ring and o-ring groove.</p>	
6	<p>Refit the o-ring.</p> <p> Tip Lubricate the o-ring with some grease for a better fitting in the groove.</p>	
7	<p> CAUTION When fitting the motor cover, make sure that none of the cables inside will be damaged.</p>	

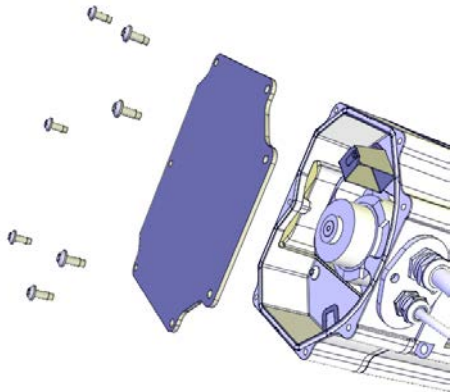
Continues on next page

	Action	Note
8	<p>Refit the motor cover with it's attachment screws.</p> <p> Note</p> <p>Do not reuse the self-threading attachment screws. Replace with standard attachment screws or the threads will be damaged.</p> <p> Note</p> <p>Make sure the o-ring is undamaged and properly fitted.</p>	<p>Attachment screws: M5x12 8.8 (7 pcs)</p>  <p>xx1200001135</p>
9	<p>Make sure that the covers are tightly sealed.</p>	

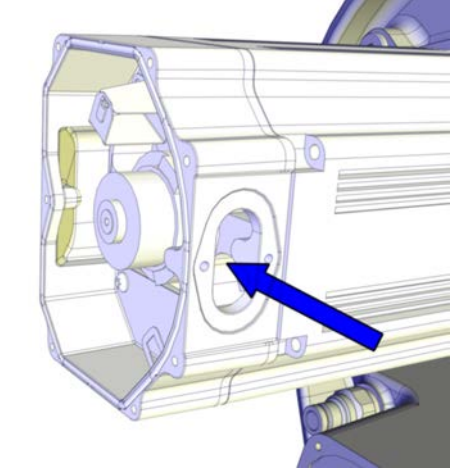
Connecting the axis-5 motor cables

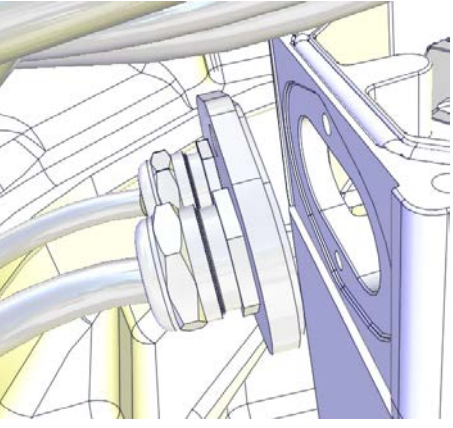

	Action	Note
1	<p>Push the motor cables in through the cable gland opening.</p>	 <p>xx1300000738</p>
2	<p>Refit the cable gland cover by performing the following steps:</p> <ul style="list-style-type: none"> • Slide the cable gland cover onto the inner screw. • Refit and tighten the outer screw. • Tighten the inner screw. Make sure that the gasket is not damaged. <p> Note</p> <p>Replace the gasket if damaged.</p>	 <p>xx1200001016</p>

Continues on next page

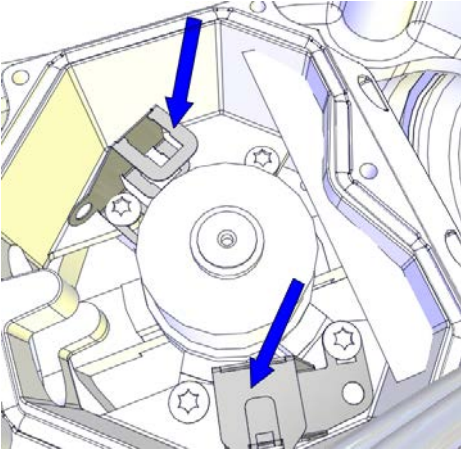
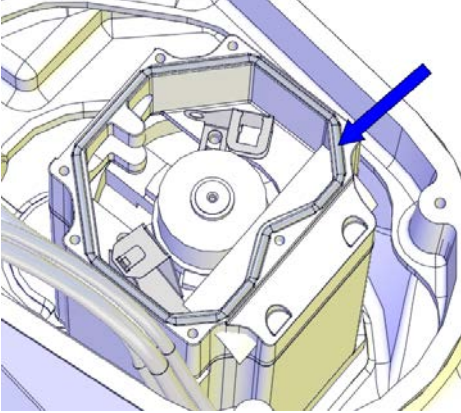

4 Repair

4.5.5 Replacing the lower arm

Continued

	Action	Note
3	Connect the connectors. Connect in accordance with the markings on the connectors.	 xx1200001015
4	Make sure the o-ring on the motor is undamaged. Replace if damaged.	O-ring, axis 5: 3HAC054692-001.  xx1200001021
5	 CAUTION When fitting the motor cover, make sure that none of the cables inside will be damaged.	

Continues on next page

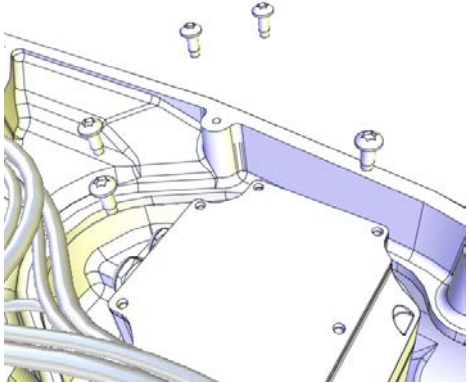
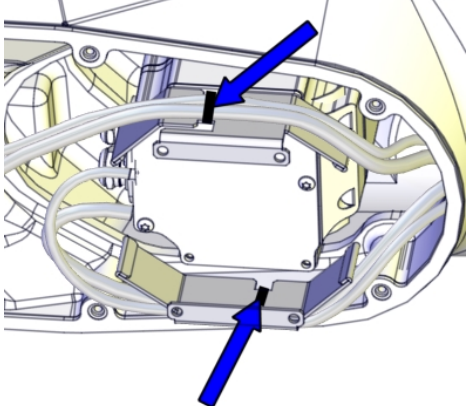
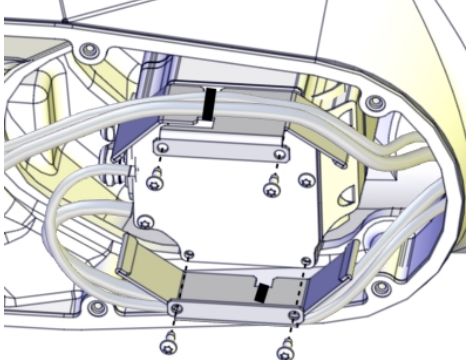
	Action	Note
6	<p>Refit the motor cover with its attachment screws.</p> <p> Note</p> <p>Do not refit the screws that will hold the heat protection plate at this point.</p> <p> Note</p> <p>Do not reuse the self-threading attachment screws, it will damage the threads. Replace with standard attachment screws.</p> <p> Note</p> <p>Make sure the o-ring is undamaged and properly fitted.</p>	<p>Screws: M5x12.</p>  <p>xx1200001013</p>
7	<p>Secure the cable harness with cable straps to the heat protection plate.</p>	 <p>xx1500001029</p>
8	<p>Fit the heat protection plate with the screws.</p>	<p>Screws: M5x12.</p>  <p>xx1500001030</p>



Continues on next page

4 Repair



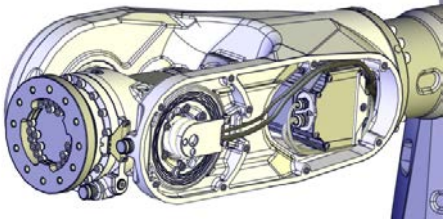

4.5.5 Replacing the lower arm

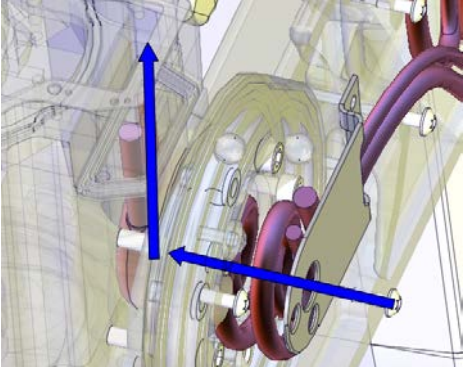
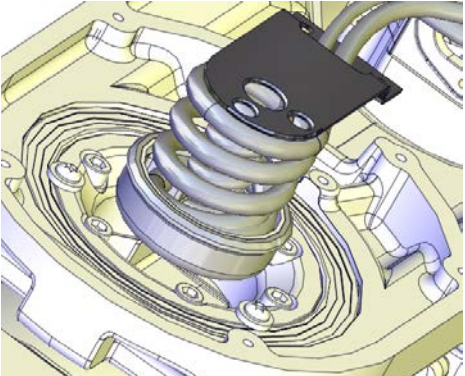
Continued

Connecting the axis-6 motor cables

	Action	Note
1	Make sure that the cable harness is placed in a way that it will not be damaged when the cover is fitted.	 xx1600002061
2	 Note Axis 5 must be in position +90° (or as close as possible) for a correct installation of the cable harness in the wrist. If not, connect the 24 VDC power supply, release the brakes and move axis 5 manually to +90°.	Position +90° of axis 5 makes the turning disc face the floor, if the robot is floor standing.
3	Push the cable harness into the wrist recess and up into the axis-6 motor.	 xx1300000667
4	Push the carrier carefully into position.	 xx1300001113

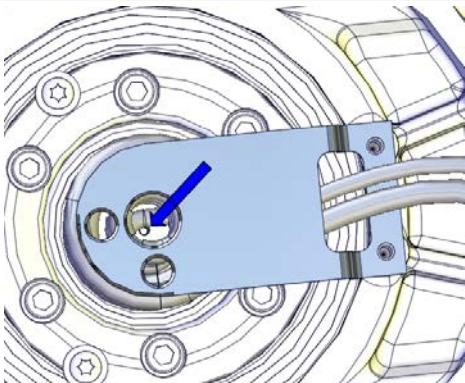
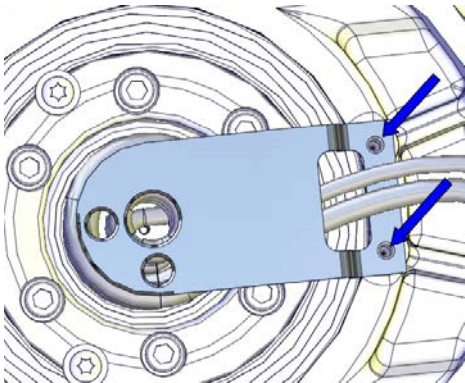
Continues on next page

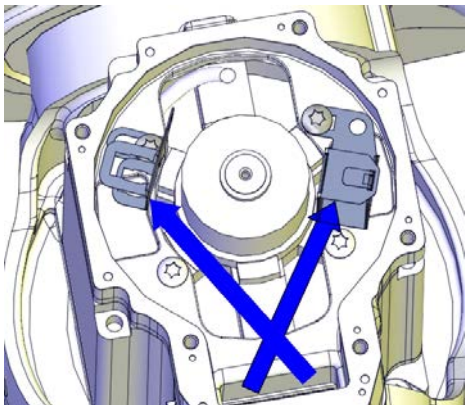

	Action	Note
5	<p>Secure the carrier with the M4 screw.</p> <p> Note</p> <p>The screw is located at the bottom of the carrier.</p> <p> Tip</p> <p>The attachment screw securing the carrier may be difficult to fit. Make sure the carrier is level and completely pressed against the bottom.</p>	 <p>xx130000485</p>
6	<p>Secure the cable bracket with its attachment screws.</p>	 <p>xx130000484</p>
7	<p>Reconnect the connectors to the axis-6 motor.</p> <p> Note</p> <p>Place the resolver cable under the motor cable.</p>	 <p>xx130000488</p>

Continues on next page

4 Repair

4.5.5 Replacing the lower arm

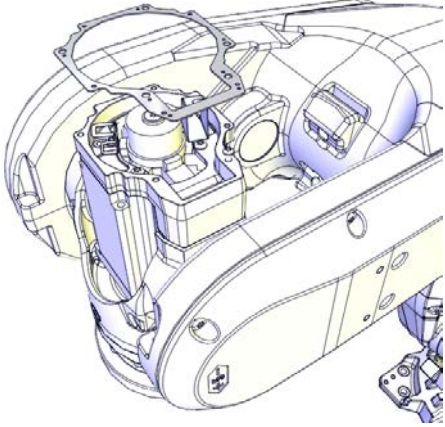
Continued

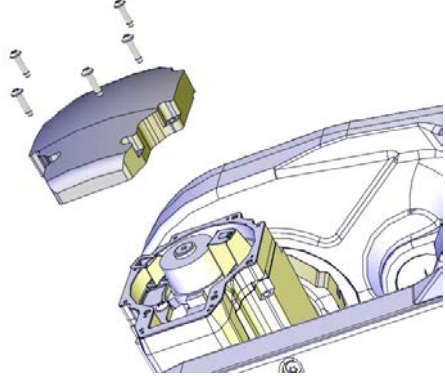
	Action	Note
8	Make sure the gasket is undamaged. Replace if damaged.	Gasket, 3HAC033489-001  xx1200001095
9	 CAUTION When fitting the motor cover, make sure that none of the cables inside will be damaged.	
10	Refit the motor cover.	 xx1200001080

Continues on next page

Concluded refitting of the cable harness

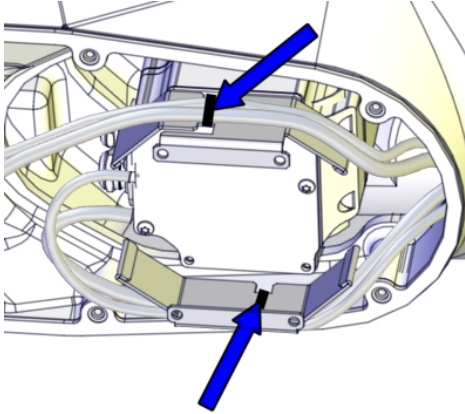
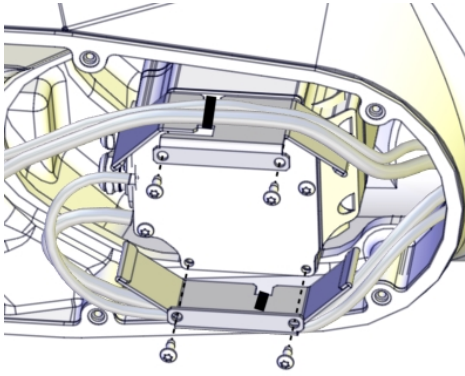
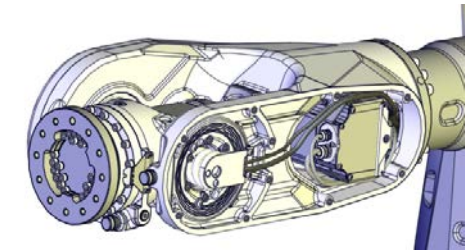
	Action	Note
1	Secure the cable harness with cable straps to the heat protection plate.	 <p>xx1500001029</p>
2	Fit the heat protection plate with the screws.	 <p>xx1500001030</p>
3	Make sure that the cable harness is placed so it will not be damaged when the wrist cover is fitted.	 <p>xx1600002061</p>

Continues on next page

4 Repair

4.5.5 Replacing the lower arm

Continued

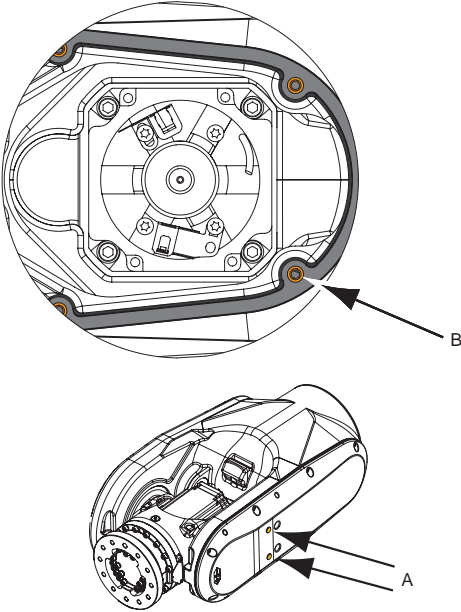
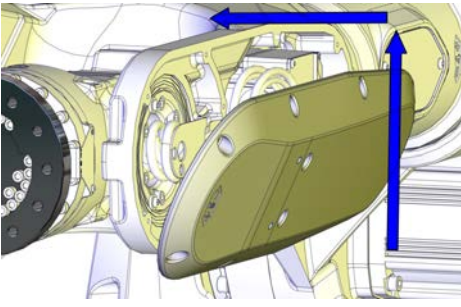
	Action	Note
4	<p>Foundry Plus: Inspect the gasket. Replace if damaged. Put washers in the holes of the gasket.</p>	 <p>xx140000383</p> <p>A Protection plugs (2 on wrist cover and 2 on cover axis-5 gearbox) B Washers (10 pcs) in gasket holes</p>
5	<p>Use caution in order not to damage the cable harness when the wrist cover is refitted, by following this method:</p> <ol style="list-style-type: none"> 1 Hold the cover tilted. See figure! 2 Put the cable harness on the cover. 3 Lift the cover, still tilted. 4 Move the upper part of the cover into position. 5 Secure the cover with its attachment screws. 	 <p>xx130000772</p> <p>Tightening torque: 10 Nm.</p>
6	<p>If the robot is equipped with DressPack cable package:</p> <ul style="list-style-type: none"> • Refit the distance to the wrist cover. • Refit the ball joint housing to the distance. • Refit the bracket with the ball joint housing to the upper arm tube. • Refit the process turning disk. 	<p>How to refit the DressPack cable package is described in the product manual "IRB 6700 DressPack". For article number see References on page 10.</p>

Continues on next page

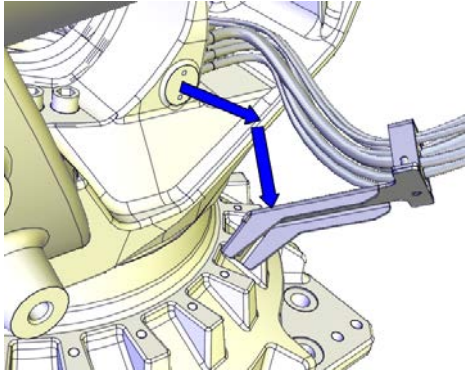
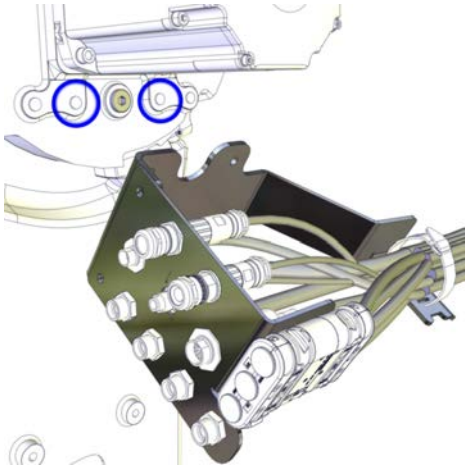
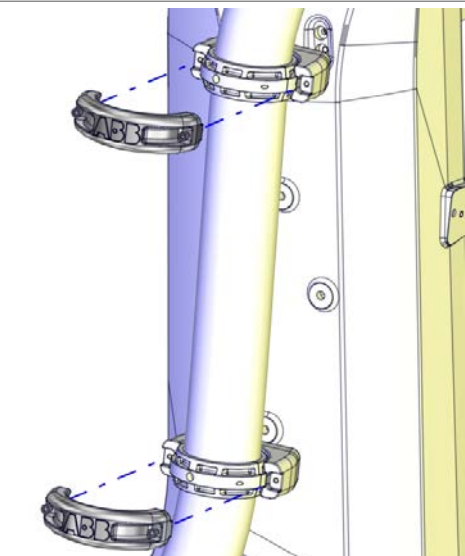
	Action	Note
7	Refit the bracket to the frame.	 <p>xx1200001184</p>
8	Refit the connection plate.	 <p>xx1200001332</p>
9	If used, refit the DressPack in the ball joint housings on the lower arm.	 <p>xx1400000195</p>





Continues on next page

4 Repair

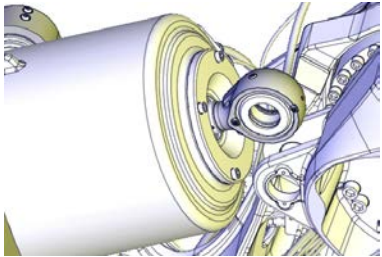
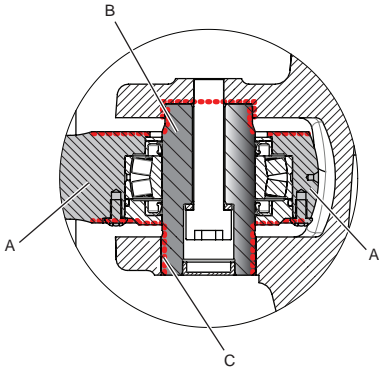

4.5.5 Replacing the lower arm

Continued

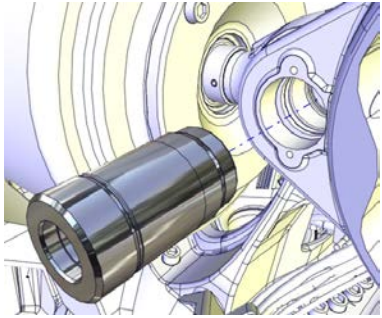
Refitting the front shaft

	Action	Note
1	<p> DANGER</p> <p>Turn off all:</p> <ul style="list-style-type: none"> • electric power supply • hydraulic pressure supply • air pressure supply <p>to the robot, before entering the safeguarded space.</p>	
2	Remove all residues of Loctite in the screw hole of the shaft.	
3	Wipe all contact surfaces inside the recess clean from residual grease or other contamination.	
4	<p>Align the balancing device link ear with the hole in the lower arm.</p> <p> Note</p> <p>Verify that the link ear is correctly turned.</p>	 <p>xx1300000784</p>
5	<p><i>Foundry Plus:</i></p> <p>Apply Mercasol on the surfaces on the shaft and front ear.</p>	 <p>xx1400000368</p> <p>A Front link ear B Shaft C Mercasol (red dotted lines)</p>
6	<p>Lubricate the shaft and place it to the front ear.</p> <p> Note</p> <p><i>Foundry Plus:</i></p> <p>Do not lubricate surfaces where Mercasol is applied.</p>	 <p>xx1200001280</p>

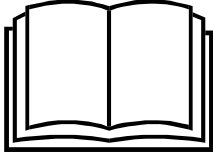
Continues on next page

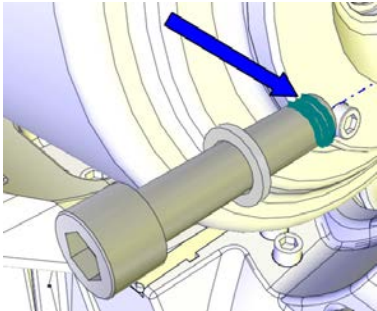
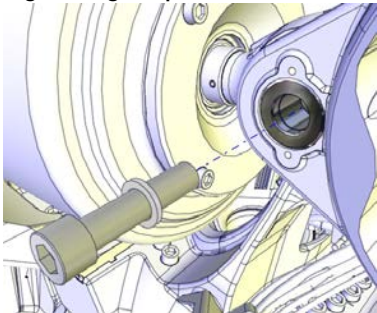
	Action	Note
7	<p>Press in the shaft using the dismantle and mounting tool, according to user instructions enclosed with the equipment.</p>  <p>xx0900000813</p> <p>Go to the user instructions enclosed with the press tool.</p> <p> DANGER</p> <p>Handling the tool incorrectly will cause serious injury. Read and follow enclosed user instructions for the tool.</p>	<p>Dismantle and mounting tool set: 3HAC028920-001 User instructions are enclosed with the tool.</p>
8	<p>Apply locking liquid on the first threads of the screw.</p>	<p>Loctite 2701</p>  <p>xx1300000782</p>
9	<p>Secure the shaft with screw and washer.</p>	<p>Tightening torque: 180 Nm</p>  <p>xx1200001279</p>

Continues on next page

4 Repair

4.5.5 Replacing the lower arm



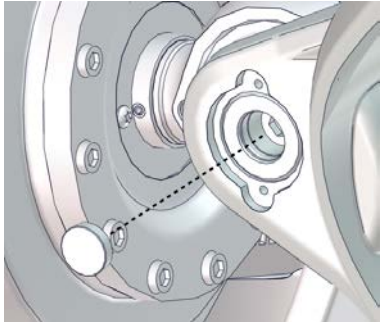
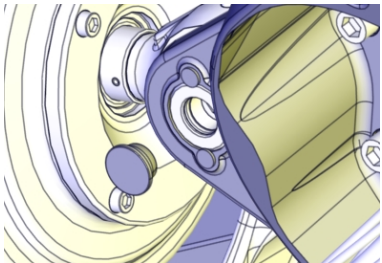
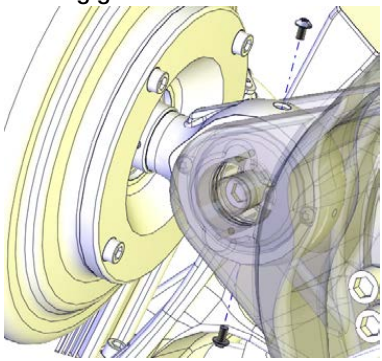

Continued

	Action	Note
10	Fit the protection plug or a new VK-cover (depends on shaft version).	 xx170000088  xx1900002311
11	Unscrew both screws in link ear. Fill the bearing with grease from the upper hole, until the grease appears in the lower hole.	Bearing grease: 3HAC042536-001  xx1300000783
12	Refit the two screws and wipe clean from residual grease.	
13	Refit the DressPack bracket, if used.	

Restoring the balancing device

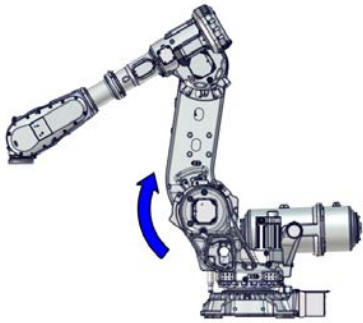
	Action	Note
1	Remove the lifting equipment from the balancing device.	

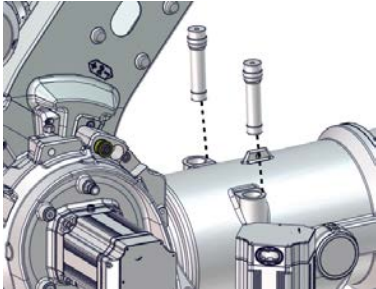
Continues on next page

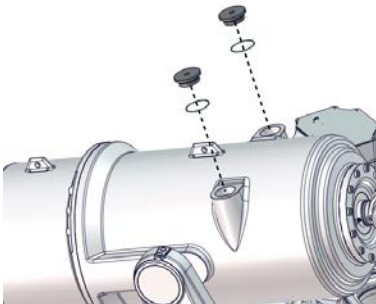
	Action	Note
2	<p>Jog axis 2 to -4° to be able to remove the relief screws.</p>	 <p>xx1700001406</p>
3	<p>Remove the relief screws to activate the balancing device.</p> <p> Note Axis 2 must be in -4°.</p>	 <p>xx1700000070</p>
4	<p>Refit the covers. Make sure that the o-rings are still fitted.</p> <p> Note Only manual force is required, no tightening torque.</p>	 <p>xx1700000451</p>

Continues on next page



4 Repair

4.5.5 Replacing the lower arm

Continued

Securing the lower arm

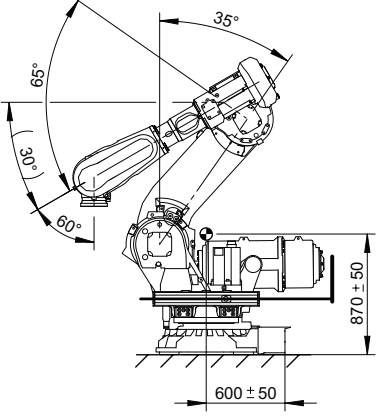
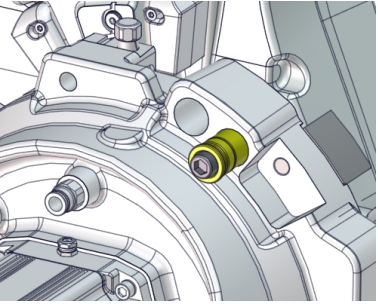
Use this procedure to secure the lower arm before lifting the robot to inverted position.

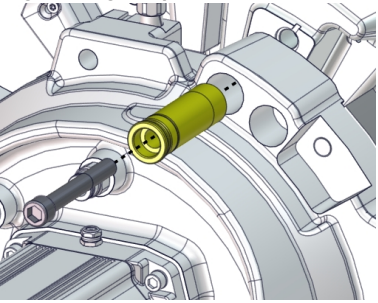
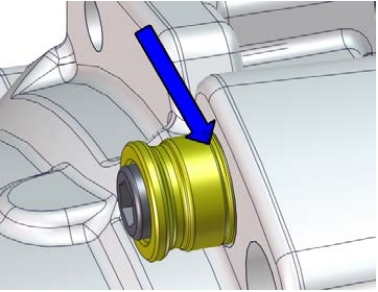
	Action	Note
1	Verify that the robot stands in position: <ul style="list-style-type: none"> • Axis 1: 0° • Axis 2: -35° • Axis 3: +65° • Axis 4: 0° • Axis 5: +60° • Axis 6: no significance 	 <p>xx1600001371</p>
2	Remove the transportation lock screw and the yellow sleeve from the parking position.	 <p>xx1700000348</p>
3	Insert the yellow sleeve and the transportation lock screw in the hole at the locking position. Insert the sleeve all the way so that the marking in the sleeve is aligned with the casting, see figure. Tighten the screw.  DANGER Always use the transportation lock screw and sleeve to lock the lower arm at transportation, turning and floor standing.	<p>Tightening torque: 70 Nm ±15 Nm.</p>  <p>xx1700000347</p>  <p>xx1600002114</p>

Continues on next page

Preparations before lifting up the robot to inverted position

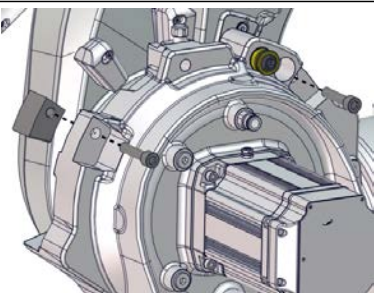
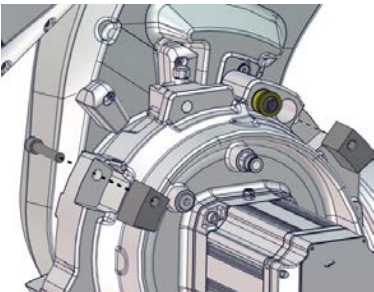
	Action	Note
1	Remove the two service stops from maintenance position, if previously moved there.	 xx170000068
2	Fit the service stops in their parking position.	 xx170000067
3	Fasten the fork lift accessory.	See user instructions enclosed with the fork lift accessory. Fork lift accessory set: 3HAC058825-001.
4	Remove the bolts securing the robot to the foundation.	

Orienting and securing the robot



	Action	Note
1	Lift the robot using the fork lift accessory.	See user instructions enclosed with the fork lift accessory.
2	Move the robot close to its installation location.	
3	Rotate the robot into inverted position using the turning tool or using a fork lift truck with a rotator attachment.  DANGER Make sure that there is enough space underneath the robot. See user instructions for the turning tool.	See user instructions enclosed with the turning tool.
4	Guide the robot using two M24 screws while lifting it into its mounting position.	

Continues on next page

4 Repair

4.5.5 Replacing the lower arm

Continued

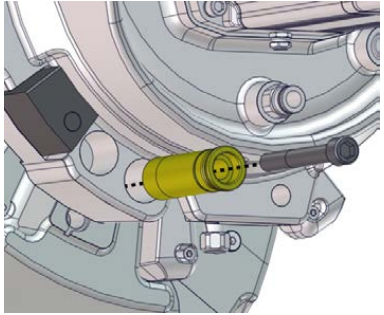
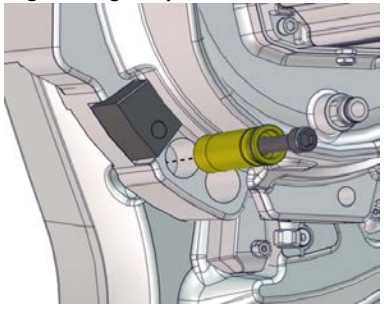
	Action	Note
5	<p>Fit the bolts and washers in the base attachment holes.</p> <p> Note</p> <p>Lightly lubricate screws before assembly.</p> <p> CAUTION</p> <p>If high stress on screws are suspected, replace used screws with new ones.</p>	<p>Suitable screws, lightly lubricated: M24x100 (8 pcs), 8.8.</p> <p>Suitable washer: 4 mm flat washer.</p> <p>Screw tightening yield point utilization factor (v) (according to VDI2230): 90% (v=0.9).</p> <p>Tightening torque: 550 Nm (screws lubricated with Molykote 1000) 600-725 Nm, typical 650 Nm (screws none or lightly lubricated)</p>
6	Tighten bolts in a crosswise pattern to ensure that the base is not distorted.	
7	Remove the yellow sleeve and transportation lock screw from the transportation and turning position.	 <p>xx1700000269</p>
8	Fasten the yellow sleeve and transportation lock screw in its parking position.	<p>Tightening torque: 70 Nm ±15 Nm.</p>  <p>xx1700000270</p>

Concluding procedure

	Action	Note
1	Remove the lifting accessory.	
2	Re-calibrate the robot.	<p>Axis Calibration is described in Calibrating with Axis Calibration method on page 694.</p> <p>General calibration information is included in section Calibration on page 683.</p>
3	<p> DANGER</p> <p>Make sure all safety requirements are met when performing the first test run. See Test run after installation, maintenance, or repair on page 97.</p>	

4.6 Frame and base

4.6.1 Replacing the spherical roller bearing

Location of the spherical roller bearing

The spherical roller bearing is located in the link ear of the balancing device.

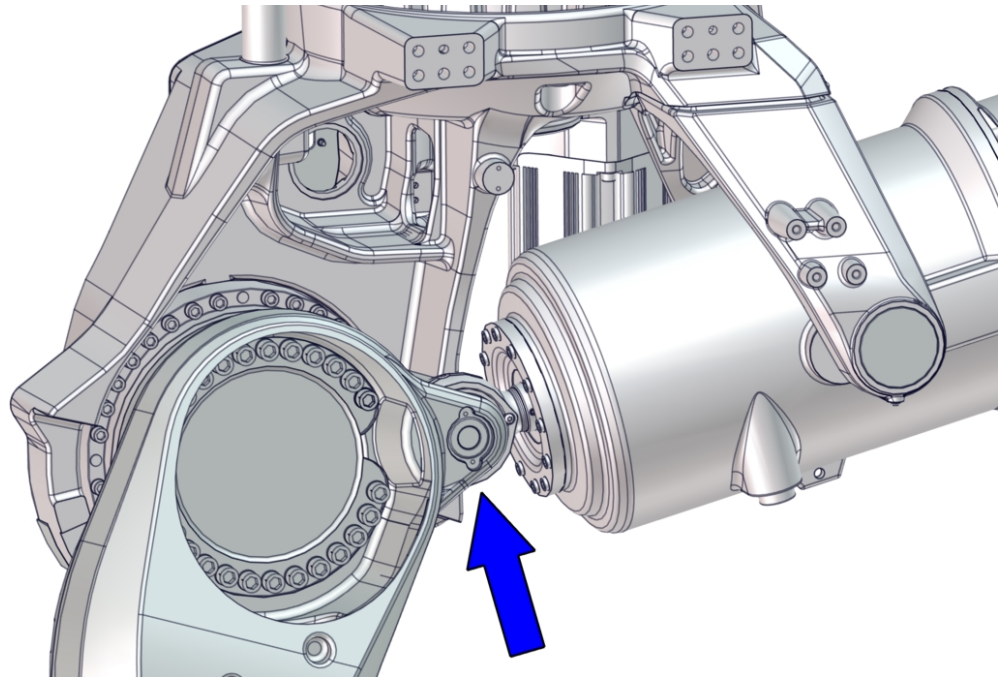

xx170000318

Summary of the replacement procedure

This is a brief summary of the replacement procedure, containing the major actions to be performed.

- 1 Unload the balancing device.
- 2 Replace the spherical roller bearing.

Spare parts



Note

The spare part numbers that are listed in the table can be out of date. See the latest spare parts of the IRB 6700Inv / IRB 6700I via myABB Business Portal, www.abb.com/myABB.

Continues on next page

4 Repair

4.6.1 Replacing the spherical roller bearing

Continued

Spare part	Article number	Note
Spherical roller bearing kit	3HAC062076-001	The maintenance kit contains: <ul style="list-style-type: none">• End cover• Radial sealing with dust lip, 50x68x8 (2 pcs)• O-ring 104.5• Spherical roller bearing• Washer

Required tools and equipment

Equipment	Article number	Note
Relief screws	3HAC058129-001	Used for unloading the balancing device. Included in spare part balancing device.
Chain block	-	Used together with a lifting sling and a lifting eye for securing the weight. The chain block included in the turning tool for the robot can be used (Turning tool: 3HAC073537-001).
Dismantle and mounting tool set	3HAC028920-001	Used for removing and fitting shaft and bearings.
Hydraulic cylinder	3HAC11731-1	To be used with the press tool.
Hydraulic pump 80 MPa	3HAC13086-1	To be used with the hydraulic cylinder.
Lifting shackle, 2 pcs	-	SA-10-8-NA1
Roundsling, 1 m	-	Lifting capacity: 1,000 kg.
Standard toolkit	-	Content is defined in section Standard toolkit on page 724 .

Consumables





Consumable	Article number	Note
VK cover, 28x7 Only compatible with shaft 3HAC044036-001. See Shaft link ear versions on page 419 .	3HAA2166-12	
Bearing grease	3HAC042536-001	Shell Gadus S2 Used for lubrication of the spherical roller bearing.
Locking liquid	-	Loctite 2400 (or equivalent Loctite 243)

Continues on next page

Removing the spherical roller bearing

Use these procedures to remove the spherical roller bearing.

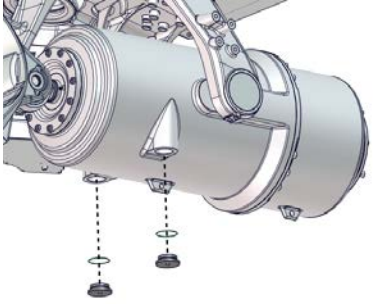
Unloading the balancing device

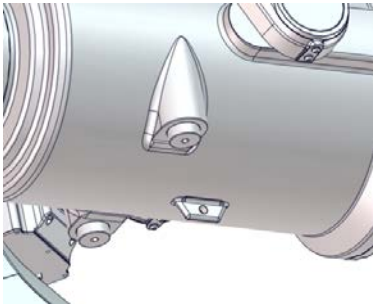
	Action	Note
1	<p>Jog axis 2 to -4° to be able to insert the relief screws.</p> <p> Note Axis 2 must be in -4°.</p>	
2	<p>Remove the covers on the balancing device.</p> <p> Note The covers have to be refitted after repair or maintenance.</p>	 <p>xx170000698</p>
3	<p>Fit the relief screws to unload the balancing device.</p> <p> DANGER Do not remove the relief screws during replacement of spherical roller bearing.</p>	<p>Tightening torque: $70 \text{ Nm} \pm 15 \text{ Nm}$ Relief screws, 3HAC058129-001</p>  <p>xx170000699</p>  <p>xx170000700</p>
4	<p>Jog the robot into position:</p> <ul style="list-style-type: none"> • Axis 1: $+25^\circ$ • Axis 2: $+15^\circ$ • Axis 3, 4, 5, 6: no significance 	

Continues on next page



4 Repair

4.6.1 Replacing the spherical roller bearing

Continued

	Action	Note
5	 DANGER Turn off all: <ul style="list-style-type: none"> • electric power supply • hydraulic pressure supply • air pressure supply to the robot, before entering the safeguarded space.	

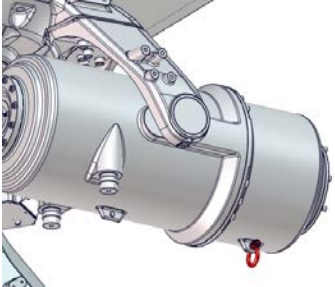
Attaching lifting accessories to the balancing device

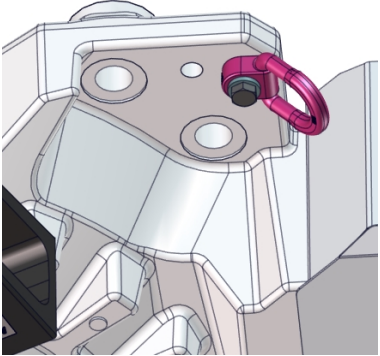

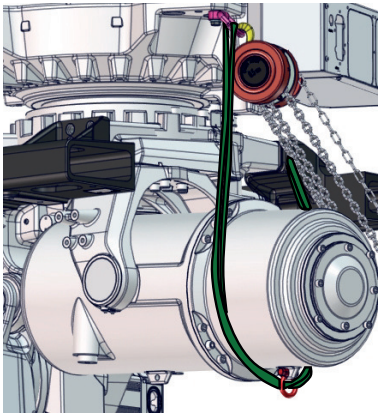

	Action	Note
1	 CAUTION The weight of the balancing device (excluding cradle) is 305 kg All lifting accessories used must be sized accordingly.	
2	Fasten a lifting shackle on the rear lifting ear.	SA-10-8-NA1  <small>xx1700000701</small>
3	Fasten a lifting sling through the shackle and around the balancing device.  Note Put a cloth between the lifting equipment and the balancing device to avoid color scratches.	Roundsling, 1 m, Lifting capacity: 1,000 kg.
4	Fasten a lifting eye in the robot foot (above the balancing device).	 <small>xx1700000711</small>

Continues on next page

4.6.1 Replacing the spherical roller bearing
Continued

	Action	Note
5	Fasten the chain block in the lifting eye.	Chain block
6	<p>Fasten the lifting sling in the chain block assembly and hold the weight of the balancing device.</p> <p> CAUTION</p> <p>The balancing device is heavy at the back, and will tip over when the link ear is loosened.</p>	 <p>xx1700000712</p>

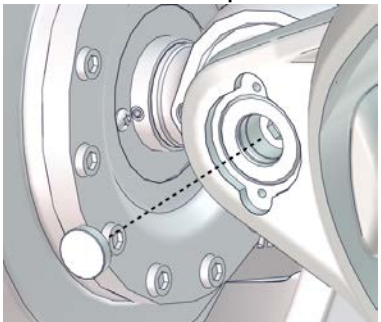
Removing the shaft in the front (link ear)

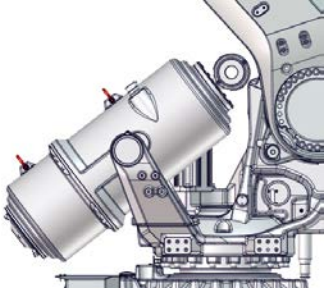
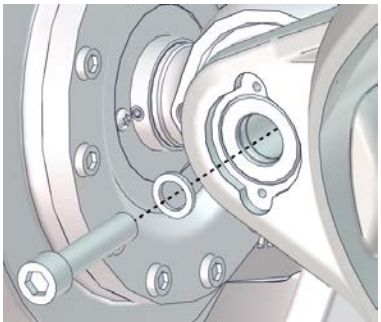
	Action	Note
1	<p>Remove the VK cover at the link ear.</p> <p> Note</p> <p>Make sure that the lifting accessories hold the weight of the balancing device.</p> <p> Tip</p> <p>Use high pressure air to remove the VK covers.</p>	<p>It is possible to drive a screwdriver (or similar) through the VK cover, as close as possible to the center of the VK cover and pull it out.</p>  <p>xx1700000088</p>
2	<p>Remove the attachment screw and washer at the link ear.</p> <p> CAUTION</p> <p>The balancing device is heavy at the back, and will tip over when the link ear is loosened.</p>  <p>xx1700000322</p>	 <p>xx1700000089</p>

Continues on next page

4 Repair

4.6.1 Replacing the spherical roller bearing

Continued

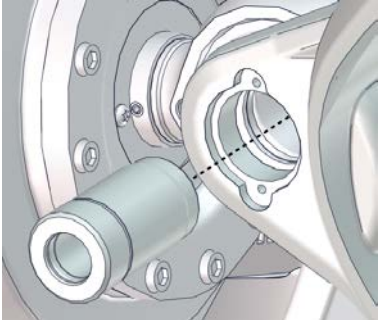

	Action	Note
3	Use the dismantle and mounting tool and pull the shaft out.	Dismantle and mounting tool set: 3HAC028920-001 Press Tool M  xx170000090
4	Raise the lifting device to lower the front link ear and give space to replace the bearing.	

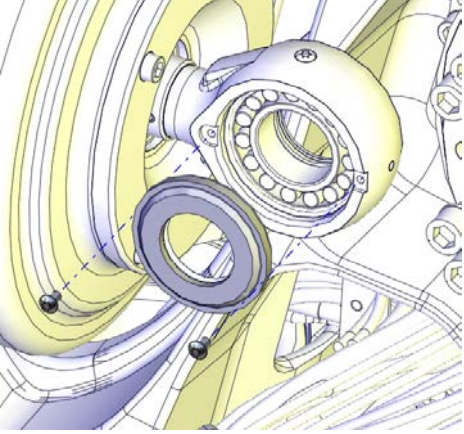
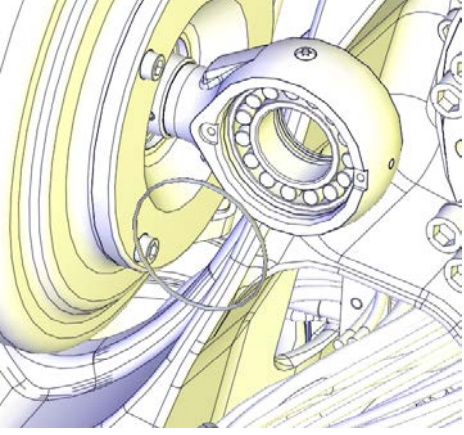
Removing the spherical roller bearing, link ear

	Action	Note
1	Check that the link ear is in a position where it is possible to apply the dismantle and mounting tool. If not, adjust with the lifting accessory.	
2	Unscrew the attachment screws securing the end cover, remove end cover and radial sealing with a screwdriver.	 xx1300000774
3	Remove the o-ring.	 xx1300000775

Continues on next page

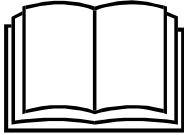
4.6.1 Replacing the spherical roller bearing
Continued

	Action	Note
4	<p>Pull the spherical roller bearing out together with the radial sealing and washer using the dismantle and mounting tool, according to user instructions enclosed with the equipment.</p>  <p>xx0900000813</p> <p>Go to the user instructions enclosed with the press tool.</p> <p> DANGER</p> <p>Handling the tool incorrectly will cause serious injury.</p> <p>Read and follow enclosed user instructions for the tool.</p>	<p>Dismantle and mounting tool set: 3HAC028920-001</p> <p>User instructions are enclosed with the tool.</p>

Refitting the spherical roller bearing

Use these procedures to refit the spherical roller bearing.

Refitting the spherical roller bearing, link ear

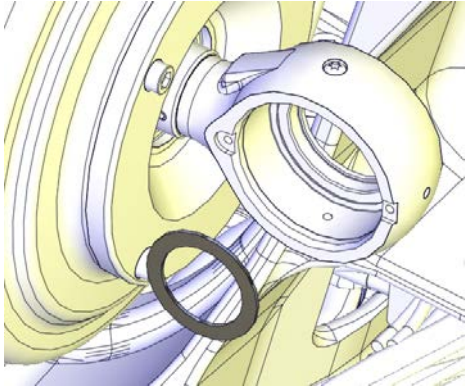

	Action	Note
1	Wipe clean all contact surfaces from residual grease.	
2	Refit the washer.	 <p>xx1300000778</p>

Continues on next page

4 Repair

4.6.1 Replacing the spherical roller bearing

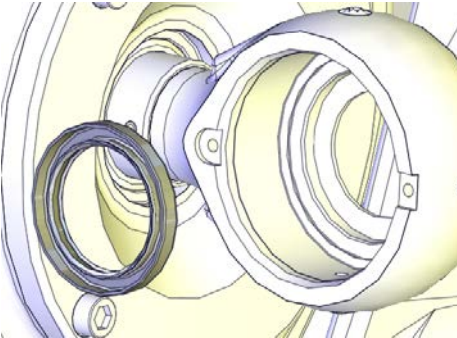
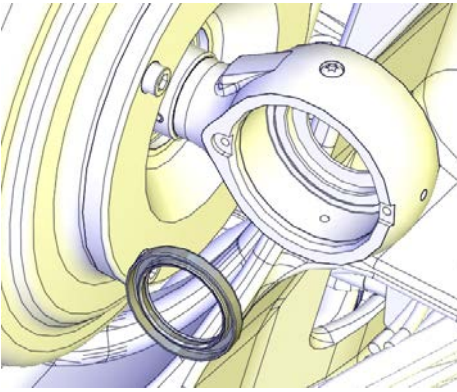
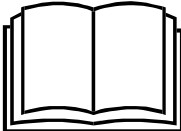
Continued

	Action	Note
3	<p>Put the radial sealing on the Press tool J.</p> <p> Note</p> <p>Make sure that the sealing is turned according to the figure.</p>	<p>Press tool J included in tool set Dismantle and mounting tool set</p>  <p>xx130000839</p>
4	<p>Use a plastic mallet or similar on the Press tool J and refit the radial sealing.</p>	 <p>xx130000777</p>
5	<p>Apply some grease on the surface for the bearing.</p>	
6	<p>Press in the spherical roller bearing using the dismantle and mounting tool, according to user instructions enclosed with the equipment.</p>  <p>xx090000813</p> <p>Go to the user instructions enclosed with the press tool.</p> <p> DANGER</p> <p>Handling the tool incorrectly will cause serious injury.</p> <p>Read and follow enclosed user instructions for the tool.</p>	<p>Dismantle and mounting tool set: 3HAC028920-001</p> <p>User instructions are enclosed with the tool.</p>

Continues on next page

4.6.1 Replacing the spherical roller bearing
Continued

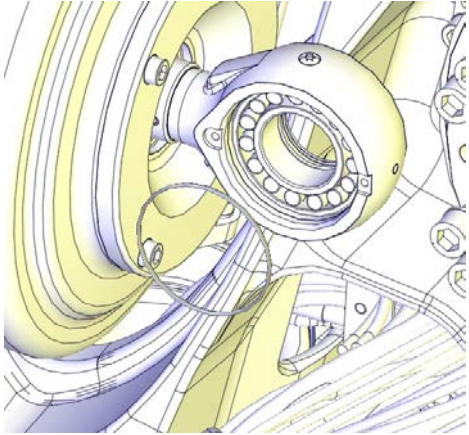
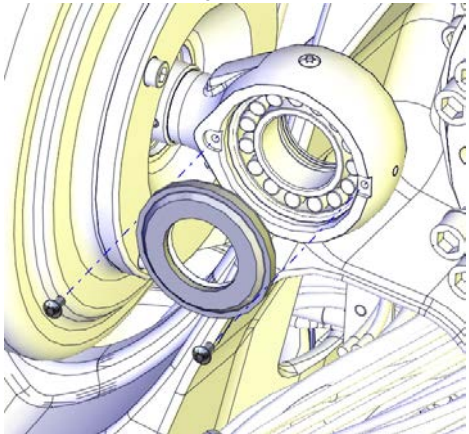
	Action	Note
7	Refit the o-ring.	 <p>xx130000775</p>
8	Apply Locking liquid on the screws and secure the end cover with the radial sealing ring.	<p>Loctite 2400 (or equivalent Loctite 243), -</p>  <p>xx130000774</p>

Release the chain block

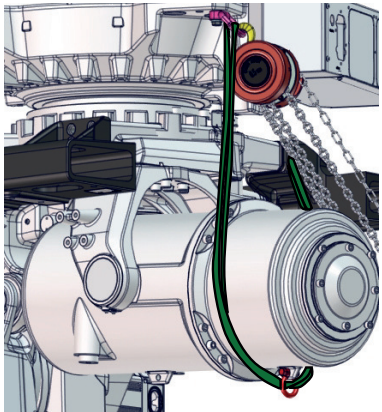
	Action	Note
1	Release the chain block to raise the front link ear on the balancing device.	 <p>xx170000712</p>
2	Align the front link ear and the spherical roller bearing.	





Continues on next page

4 Repair

4.6.1 Replacing the spherical roller bearing

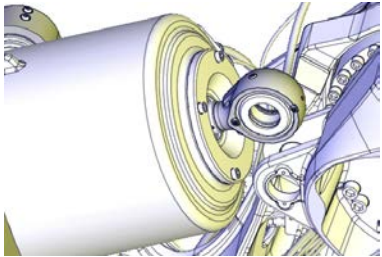
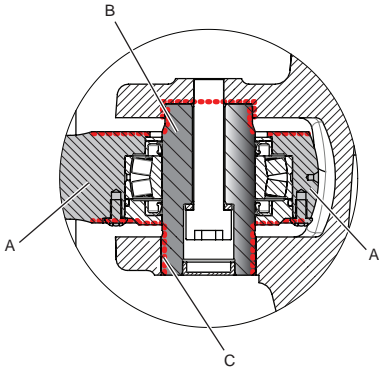

Continued

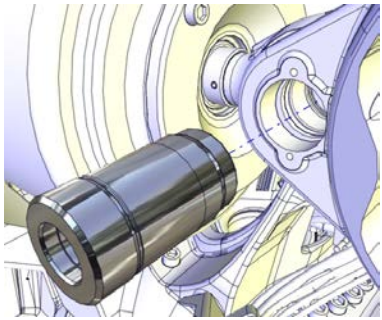
Refitting the front shaft

	Action	Note
1	 DANGER Turn off all: <ul style="list-style-type: none"> • electric power supply • hydraulic pressure supply • air pressure supply to the robot, before entering the safeguarded space.	
2	Remove all residues of Loctite in the screw hole of the shaft.	
3	Wipe all contact surfaces inside the recess clean from residual grease or other contamination.	
4	Align the balancing device link ear with the hole in the lower arm.  Note Verify that the link ear is correctly turned.	 xx1300000784
5	<i>Foundry Plus:</i> Apply Mercasol on the surfaces on the shaft and front ear.	 xx1400000368 A Front link ear B Shaft C Mercasol (red dotted lines)
6	Lubricate the shaft and place it to the front ear.  Note <i>Foundry Plus:</i> Do not lubricate surfaces where Mercasol is applied.	 xx1200001280

Continues on next page

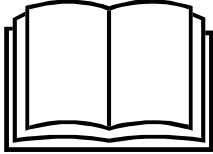
4.6.1 Replacing the spherical roller bearing
Continued

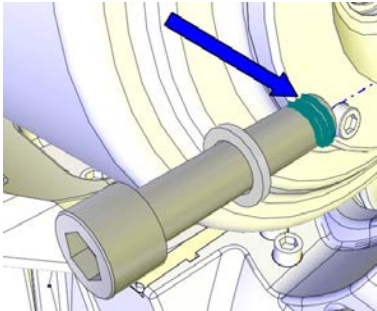
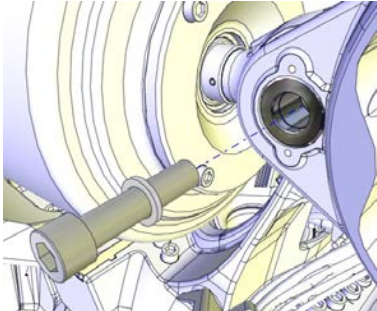
	Action	Note
7	<p>Press in the shaft using the dismantle and mounting tool, according to user instructions enclosed with the equipment.</p>  <p>xx0900000813</p> <p>Go to the user instructions enclosed with the press tool.</p> <p> DANGER</p> <p>Handling the tool incorrectly will cause serious injury. Read and follow enclosed user instructions for the tool.</p>	<p>Dismantle and mounting tool set: 3HAC028920-001 User instructions are enclosed with the tool.</p>
8	<p>Apply locking liquid on the first threads of the screw.</p>	<p>Loctite 2701</p>  <p>xx1300000782</p>
9	<p>Secure the shaft with screw and washer.</p>	<p>Tightening torque: 180 Nm</p>  <p>xx1200001279</p>

Continues on next page

4 Repair

4.6.1 Replacing the spherical roller bearing

Continued

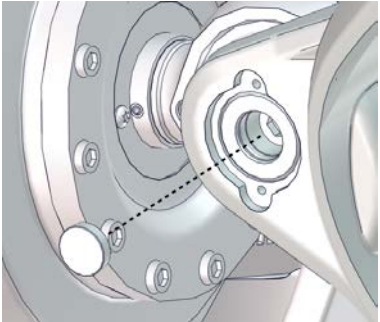
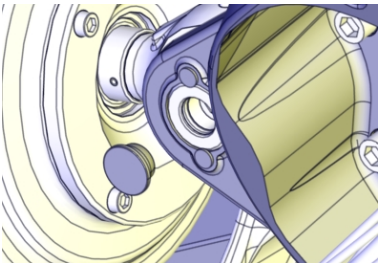
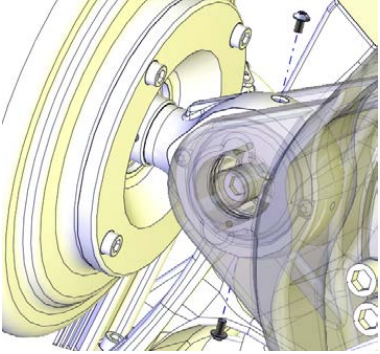
	Action	Note
10	Fit the protection plug or a new VK-cover (depends on shaft version).	 <p data-bbox="1029 638 1141 660">xx170000088</p>  <p data-bbox="1029 945 1141 967">xx1900002311</p>
11	Unscrew both screws in link ear. Fill the bearing with grease from the upper hole, until the grease appears in the lower hole.	<p data-bbox="1029 1003 1410 1025">Bearing grease: 3HAC042536-001</p>  <p data-bbox="1029 1393 1141 1415">xx1300000783</p>
12	Refit the two screws and wipe clean from residual grease.	
13	Refit the DressPack bracket, if used.	

Remove lifting accessories

	Action	Note
1	Remove the chain block.	

Continues on next page

4.6.1 Replacing the spherical roller bearing
Continued

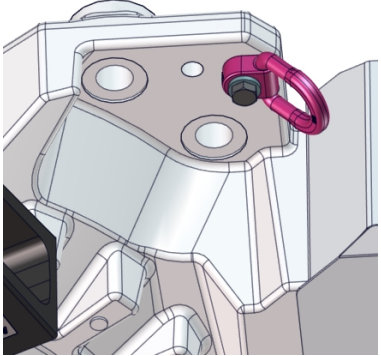
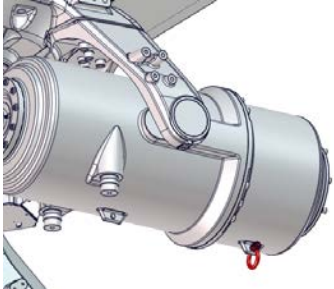
	Action	Note
2	Remove the lifting eye in robot foot.	 <p>xx170000711</p>
3	Remove the lifting sling.	
4	Remove the lifting shackle on the balancing device.	 <p>xx170000701</p>

Restoring the balancing device

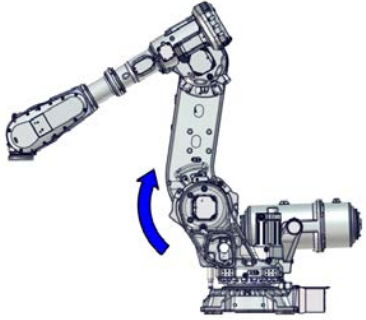

	Action	Note
1	Remove the lifting equipment from the balancing device.	
2	Jog axis 2 to -4° to be able to remove the relief screws.	 <p>xx1700001406</p>

Continues on next page

4 Repair

4.6.1 Replacing the spherical roller bearing

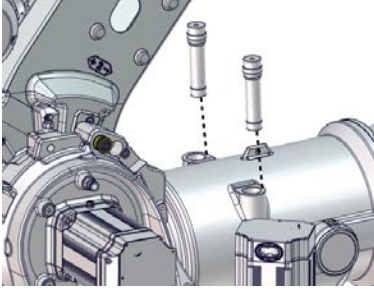
Continued

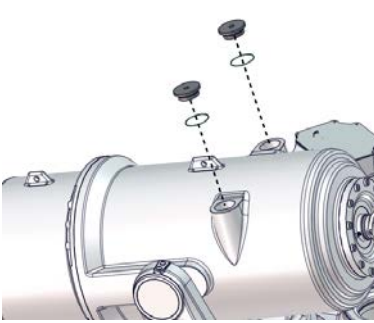
	Action	Note
3	<p>Remove the relief screws to activate the balancing device.</p> <p> Note</p> <p>Axis 2 must be in -4°.</p>	 <p>xx170000070</p>
4	<p>Refit the covers. Make sure that the o-rings are still fitted.</p> <p> Note</p> <p>Only manual force is required, no tightening torque.</p>	 <p>xx1700000451</p>

4.6.2 Replacing the balancing device

Location of the balancing device

The balancing device is located as shown in the figure.

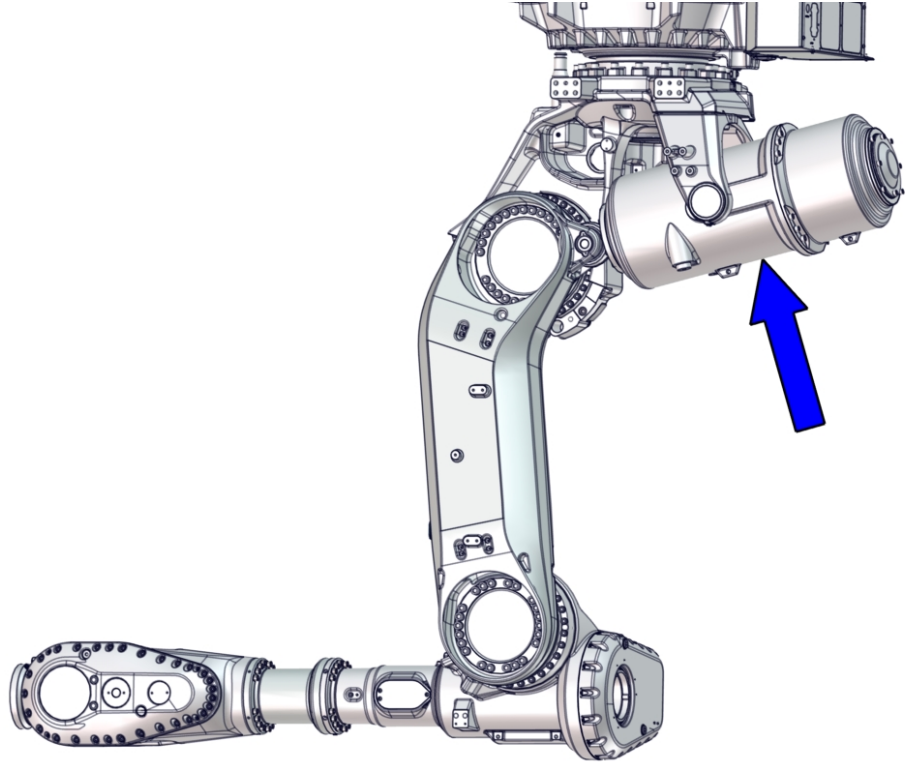

xx170000060



Note

The robot must be taken down and secured floor standing to perform this replacement procedure.

How to do this is described in the removal procedure in this section.



DANGER

Always lock the position of the lower arm, using the yellow sleeve and transportation lock screw, before attempting to lift the robot.

Summary of the replacement procedure

This is a brief summary of the replacement procedure, containing the major actions to be performed.

- 1 Lift down the robot to floor standing.
- 2 Unload the balancing device.
- 3 Replace the balancing device.
- 4 Lift up and rotate the robot to inverted position.

Continues on next page

4 Repair

4.6.2 Replacing the balancing device

Continued

Required spare parts



Note

The spare part numbers that are listed in the table can be out of date. See the latest spare parts of the IRB 6700Inv / IRB 6700I via myABB Business Portal, www.abb.com/myABB.

Spare part	Article number	Note
Balancing device	3HAC058121-005 Graphite White 3HAC058121-006 ABB Orange	

Required tools and equipment

Equipment, etc.	Article number	Note
Relief screws	3HAC058129-001	Used for unloading the balancing device. Included in spare part balancing device.
Dismantle and mounting tool set	3HAC028920-001	Used for removing and fitting shaft and bearings.
Threaded bar, M16x340	-	
Hydraulic cylinder	3HAC11731-1	To be used with the press tool.
Hydraulic pump 80 MPa	3HAC13086-1	To be used with the hydraulic cylinder.
Roundsling, 1 m	-	Lifting capacity: 1,000 kg.
Lifting shackle, 2 pcs	-	SA-10-8-NA1
Fork lift accessory set	3HAC058825-001	Contains fork lift pockets and all required hardware for installation. User instructions are enclosed with the tool, see Directions for use - Fork lift accessory 3HAC058825-001. In order to rotate the robot, either use the turning tool or a fork lift truck with a rotator attachment.
Turning tool	3HAC073537-001	Lift and rotation of inverted robot. Requires fork lift accessory set 3HAC058825-001. User instructions are enclosed with the tool.
Standard toolkit	-	Content is defined in section Standard toolkit on page 724 .

Required consumables

Equipment, etc.	Article number	Note
Bearing grease	3HAC042536-001	Shell Gadus S2 Used for lubrication of the bearings at the cradle.

Continues on next page

Equipment, etc.	Article number	Note
Bearing grease	3HAC042536-001	Shell Gadus S2 Used for lubrication of the spherical roller bearing.
(2 pcs) VK cover, 28x7 Only compatible with shaft 3HAC044036-001. See Shaft link ear versions on page 419 .	3HAA2166-12	Located at the front link ear of the balancing device.
(2 pcs) Protection plug Only compatible with shaft 3HAC072597-001. See Shaft link ear versions on page 419 .	3HAC4836-26	Located at the front link ear of the balancing device.
VK cover, 100x10 (2 pcs)	3HAA2166-13	Located at the cradle of the balancing device.
Locking liquid		Loctite 2701
Locking liquid	-	Loctite 2400 (or equivalent Loctite 243)

Shaft link ear versions

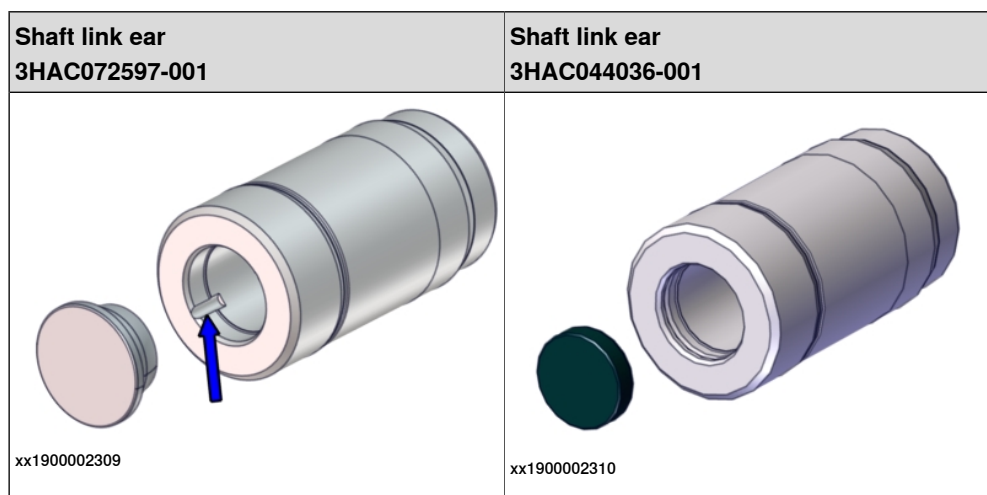

Required documents

Document	Document number
Directions for use - Fork lift accessory 3HAC058825-001	3HAC060303-001
Directions for use - Lifting and rotating accessory for IRB 6700Inv/IRB6700I	3HAC073537-003

Continues on next page

4 Repair

4.6.2 Replacing the balancing device



Continued

Removing the balancing device

Use these procedures to remove the balancing device.

Securing the lower arm

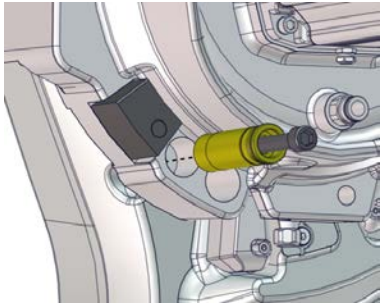

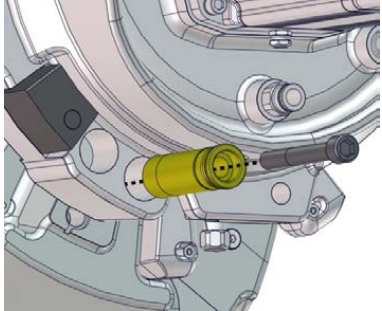
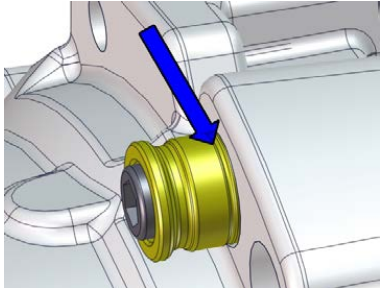

Use this procedure to secure the lower arm.

	Action	Note
1	Jog axis 2 to -35° .	
2	Remove the transportation lock screw and the yellow sleeve from the parking position.	 xx1700000270
3	Insert the yellow sleeve and the transportation lock screw in the hole at the locking position. Insert the sleeve all the way so that the marking in the sleeve is aligned with the casting, see figure. Tighten the screw.  DANGER Always use the transportation lock screw and sleeve to lock the lower arm at transportation, turning and floor standing.	Tightening torque: $70 \text{ Nm} \pm 15 \text{ Nm}$.  xx1700000269  xx1600002114

Lifting down the robot from inverted position

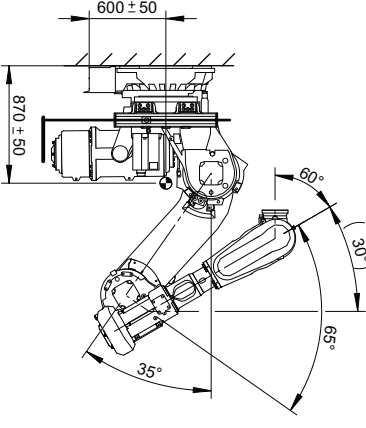
	Action	Note
1	 DANGER The robot must always be secured to the foundation if any kind of repair or maintenance work is to be performed. For some repair work support legs are required.	Suitable screws, lightly lubricated: M24x100 (min. 4 pcs) For hole configuration, see Hole configuration, base on page 66 .

Continues on next page



	Action	Note
2	Verify that the lower arm is secured with the transportation lock screw.	
3	Remove any payload and tools from the robot.	DressPack can stay fitted.
4	<p>Jog the robot into position:</p> <ul style="list-style-type: none"> • Axis 1: 0° • Axis 2: already in position and locked with the transportation lock screw, do not jog! • Axis 3: +65° • Axis 4: 0° • Axis 5: +60° • Axis 6: no significance 	 <p>xx1700000555</p>
5	<p> DANGER</p> <p>Turn off all:</p> <ul style="list-style-type: none"> • electric power supply • hydraulic pressure supply • air pressure supply <p>to the robot, before entering the safeguarded space.</p>	
6	Disconnect the robot cables at the base.	
7	<p> CAUTION</p> <p>The weight of the IRB 6700Inv / IRB 6700I robot is 1,750 kg All lifting accessories used must be sized accordingly.</p>	
8	<p>Install the fork lift pockets to the robot.</p> <p> DANGER</p> <p>Handling the tool incorrectly will cause serious injury. Read and follow enclosed user instructions for the tool.</p>	<p>See user instructions enclosed with the fork lift accessory set. Fork lift accessory set: 3HAC058825-001.</p>

Continues on next page

4 Repair

4.6.2 Replacing the balancing device

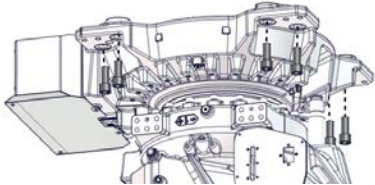

Continued

	Action	Note
9	<p>Choose one of the following lifting methods:</p> <ul style="list-style-type: none"> Lifting and turning with the fork lift (rotator attachment required): <ol style="list-style-type: none"> 1 Insert the forks of the fork lift truck into the fork lift pockets, as far as possible. 2 Raise the forks of the fork lift truck to make sure that the weight of the robot rests on the forks. <p> Tip</p> <p>Two M16 screws can be fitted to the fork lift pockets, to press the forks against the pockets and make the lift more stable.</p> Lifting and turning with the turning tool and overhead crane: <ol style="list-style-type: none"> 1 Install and use the turning tool according to enclosed user instructions. <p> DANGER</p> <p>Handling the tool incorrectly will cause serious injury. Read and follow enclosed user instructions for the tool.</p> 	<p>See user instructions enclosed with the turning tool. Turning tool: 3HAC073537-001.</p>
10	Remove the bolts that secure the robot to the foundation.	<p>Quantity: 8 pcs.</p>  <p>xx1600002098</p>
11	Rotate the robot to floor standing position.	Follow the user instructions enclosed with the turning tool.
12	<p>Lower and secure the robot to the floor. (Or to support legs, if replacing the axis-1 gear-box.)</p> <p>The lifting accessories can be kept installed if they are not in the way for the upcoming service procedure.</p>	Attachment screws: M24x100 (min. 4 pcs required to perform service)

Unloading the balancing device

	Action	Note
1	Verify that the robot is secured to the foundation.	Attachment screws: M24x100 (8 pcs).

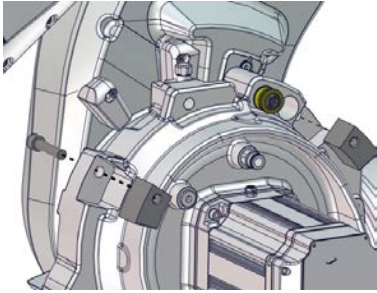
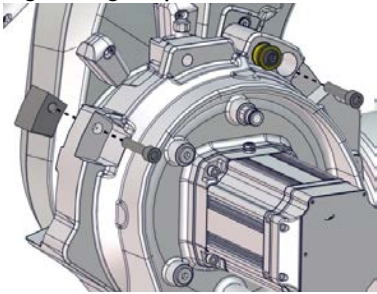
Continues on next page

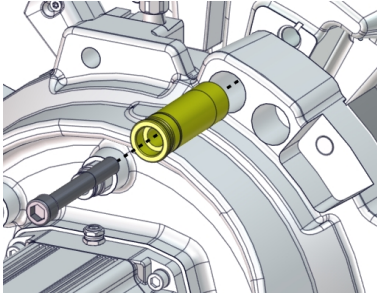
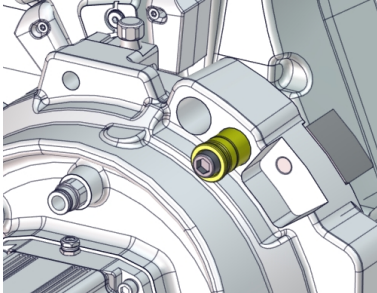



	Action	Note
2	Remove the two service stops from their parking position.	 <p>xx170000067</p>
3	Fit the service stops in maintenance position.	<p>Tightening torque: 70 Nm ±15 Nm.</p>  <p>xx170000068</p>
4	<p>Remove the transportation lock screw and yellow sleeve from locking position.</p> <p> Note</p> <p>It is only allowed to remove the transportation lock screw and sleeve, if the service stops are in maintenance position, when the robot is floor standing.</p>	 <p>xx1700000347</p>
5	Fit the transportation lock screw and the yellow sleeve in their parking position.	 <p>xx1700000348</p>

Continues on next page

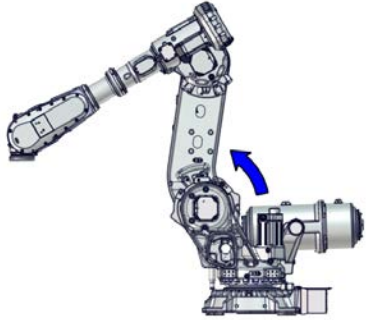

4 Repair

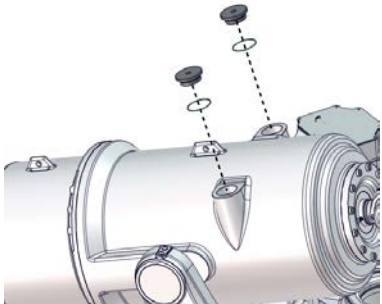
4.6.2 Replacing the balancing device

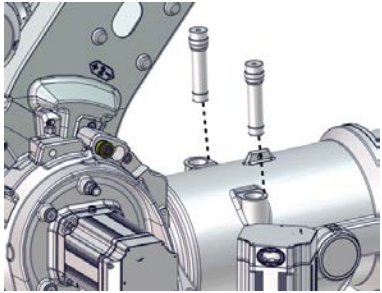
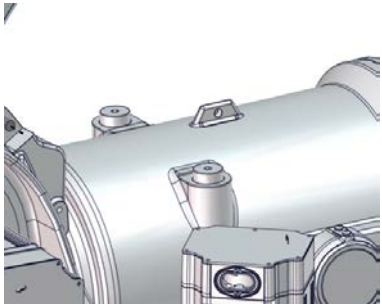
Continued

	Action	Note
6	<p>Jog axis 2 to -4° to be able to insert the relief screws.</p>	 <p>xx1700001404</p>
7	<p>Remove the covers on the balancing device.</p> <p> Note</p> <p>The covers have to be refitted after repair or maintenance.</p>	 <p>xx1700000451</p>
8	<p>Fit the relief screws to unload the balancing device.</p> <p> DANGER</p> <p>Do not remove the relief screws when the balancing device is removed from the robot.</p>	<p>Tightening torque: $70 \text{ Nm} \pm 15 \text{ Nm}$ Relief screws, 3HAC058129-001</p>  <p>xx1700000070</p>  <p>xx1700000560</p>

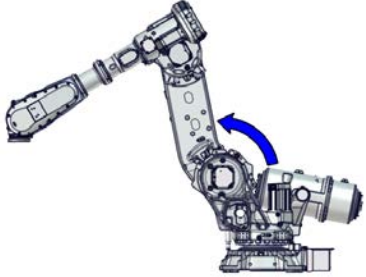
Continues on next page

	Action	Note
9	Jog axis 2 to +15°.	 <p>xx1700001405</p>
10	 <p>DANGER</p> <p>Turn off all:</p> <ul style="list-style-type: none"> • electric power supply • hydraulic pressure supply • air pressure supply <p>to the robot, before entering the safeguarded space.</p>	



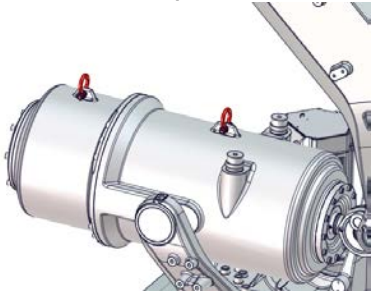

Attaching lifting accessories to the balancing device

	Action	Note
1	 <p>CAUTION</p> <p>The weight of the balancing device (excluding cradle) is 305 kg All lifting accessories used must be sized accordingly.</p>	
2	Fasten lifting shackles on the balancing device.	<p>SA-10-8-NA1 (2 pcs)</p>  <p>xx1700000086</p>

4 Repair

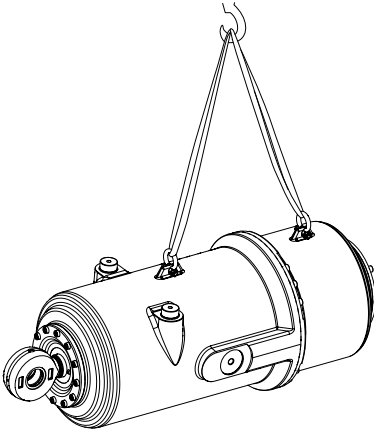
4.6.2 Replacing the balancing device

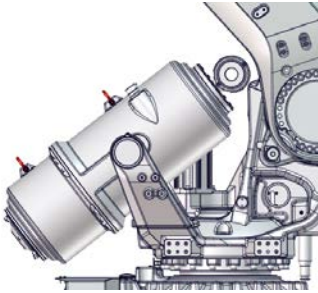

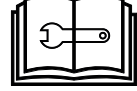
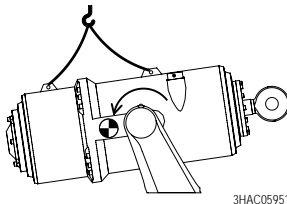

Continued

	Action	Note
3	Fasten the lifting slings.	<p>Roundsling, 1 m (2 pcs) Lifting capacity: 1,000 kg.</p>  <p>xx170000087</p>
4	<p>Raise the lifting slings to take the weight of the balancing device.</p> <p> CAUTION</p> <p>The balancing device is heavy at the back, and will tip over when the link ear is loosened.</p>  <p>xx1700000322</p>	   <p>3HAC059516-001 (2)</p> <p>xx1600002060</p>

Removing the balancing device

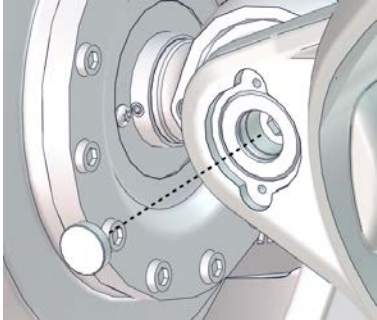
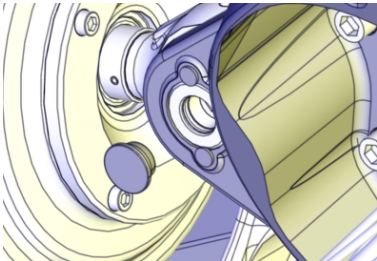
	Action	Note
1	Loosen the DressPack bracket, if mounted.	

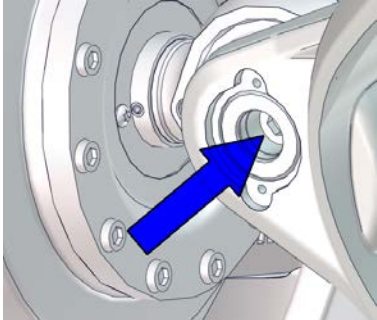
Continues on next page

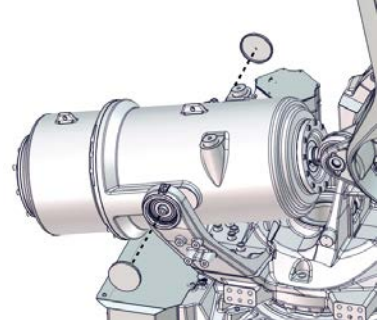



	Action	Note
2	Remove the protection plug or VK cover at the link ear (depends on shaft version).	It is possible to drive a screwdriver (or similar) through the VK cover, as close as possible to the center of the VK cover and pull it out.  <p>xx170000088</p>  <p>xx1900002311</p>
3	Loosen the attachment screw.  Note Make sure that the lifting accessories hold the weight of the balancing device.	 <p>xx170000092</p>
4	Remove the VK covers at the cradle.  Tip Use high pressure air to remove the VK covers.	It is possible to drive a screwdriver (or similar) through the VK cover, as close as possible to the center of the VK cover.  <p>xx170000091</p>
5	Wipe off all residual grease inside the recess.	

Continues on next page

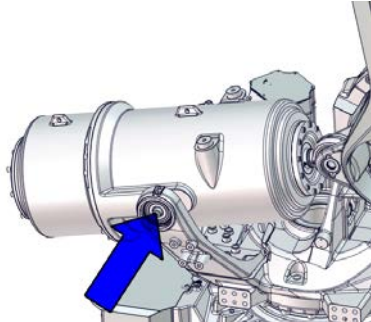

4 Repair

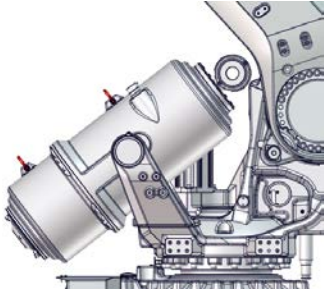
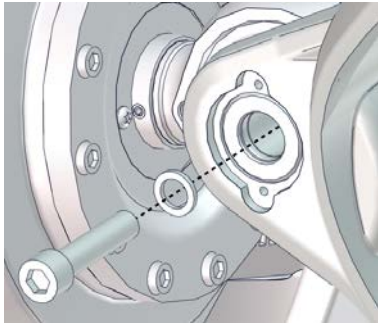
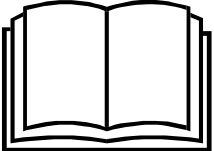
4.6.2 Replacing the balancing device

Continued

	Action	Note
6	Loosen the attachment screws.	 <p>xx170000093</p>
7	<p>Remove the attachment screw and washer at the link ear.</p> <p> CAUTION</p> <p>The balancing device is heavy at the back, and will tip over when the link ear is loosened.</p>  <p>xx1700000322</p>	 <p>xx170000089</p>
8	<p>Pull the shaft out using the dismantle and mounting tool, according to user instructions enclosed with the equipment.</p>  <p>xx0900000813</p> <p>Go to the user instructions enclosed with the press tool.</p> <p> DANGER</p> <p>Handling the tool incorrectly will cause serious injury.</p> <p>Read and follow enclosed user instructions for the tool.</p>	<p>Dismantle and mounting tool set: 3HAC028920-001</p> <p>User instructions are enclosed with the tool.</p>

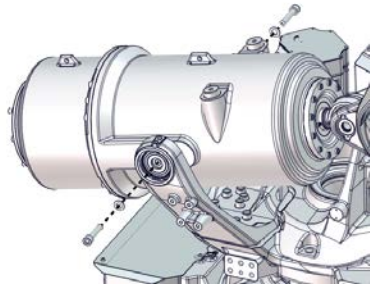
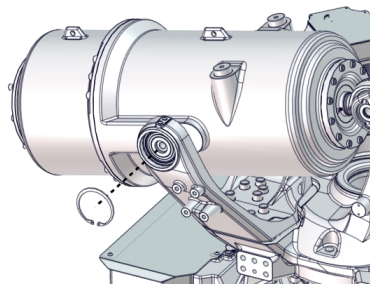
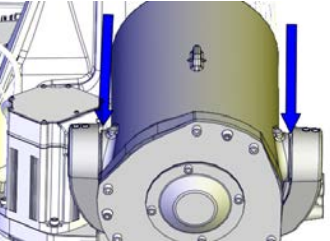
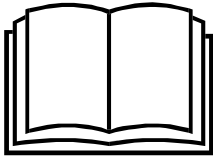
Continues on next page

	Action	Note
9	Remove attachment screws and washers at the cradle.	 <p>xx170000094</p>
10	Remove the retaining ring bore.	 <p>xx1700000343</p>
11	Put a big screw driver between the cradle and balancing device and use it as a distance tool.	 <p>xx1300000838</p>
12	<p>Pull out the shaft end and groove ball bearing using the dismantle and mounting tool, according to user instructions enclosed with the equipment.</p>  <p>xx0900000813</p> <p>Go to the user instructions enclosed with the press tool.</p> <p> DANGER</p> <p>Handling the tool incorrectly will cause serious injury. Read and follow enclosed user instructions for the tool.</p>	<p>Dismantle and mounting tool set: 3HAC028920-001 User instructions are enclosed with the tool.</p>

Continues on next page

4 Repair

4.6.2 Replacing the balancing device

Continued

Refitting the balancing device

Use these procedures to refit the balancing device.

Attaching lifting accessories to the balancing device

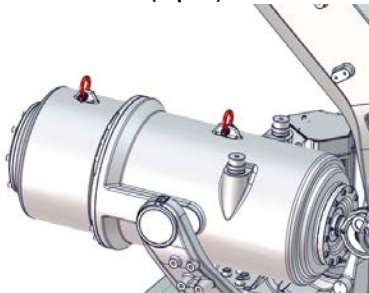
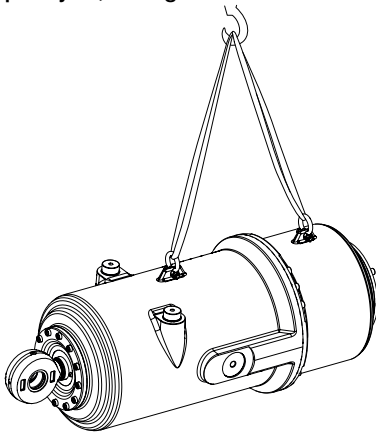
	Action	Note
1	 CAUTION The weight of the balancing device (excluding cradle) is 305 kg All lifting accessories used must be sized accordingly.	
2	Fasten lifting shackles on the balancing device.	SA-10-8-NA1 (2 pcs)  xx170000086
3	Fasten the lifting slings.	Roundsling, 1 m (2 pcs) Lifting capacity: 1,000 kg.  xx170000087

Continues on next page

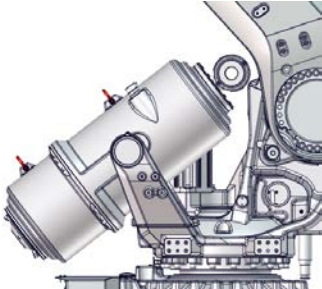
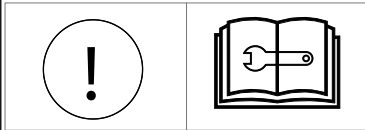
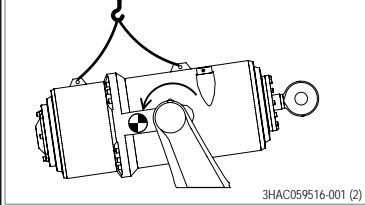
	Action	Note
4	<p>Raise the lifting slings to take the weight of the balancing device.</p> <p> CAUTION</p> <p>The balancing device is heavy at the back, and will tip over when the link ear is loosened.</p>  <p>xx170000322</p>	  <p>3HAC059516-001 (2)</p> <p>xx1600002060</p>

Refitting the rear shafts

Perform this procedure on both sides of the balancing device.

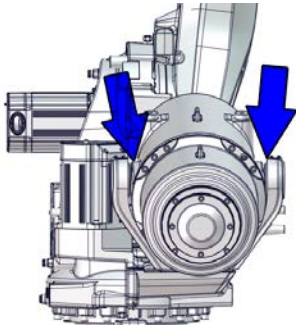

	Action	Note
1	<p> DANGER</p> <p>Turn off all:</p> <ul style="list-style-type: none"> • electric power supply • hydraulic pressure supply • air pressure supply <p>to the robot, before entering the safeguarded space.</p>	
2	Lift the balancing device into position in the cradle.	
3	Apply a big screwdriver between the cradle and the balancing device, when the shafts are refitted.	 <p>xx1700000096</p>

Continues on next page

4 Repair

4.6.2 Replacing the balancing device

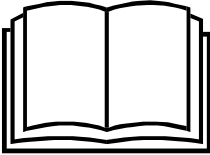

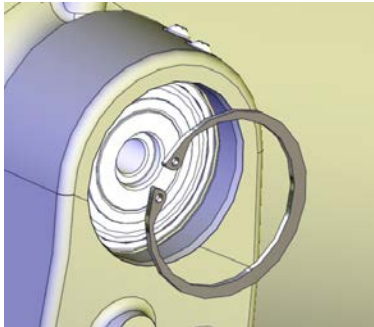
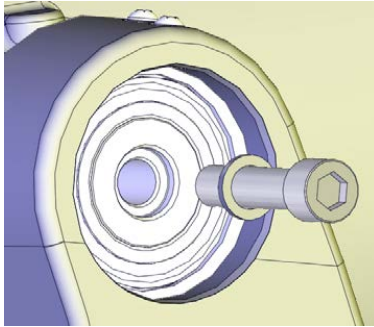
Continued

	Action	Note
4	<p>Apply the refitting tool and press the shafts into position one at a time.</p>  <p>xx0900000813</p> <p>Go to the user instructions enclosed with the press tool.</p> <p> DANGER</p> <p>Handling the tool incorrectly will cause serious injury. Read and follow enclosed user instructions for the tool.</p>	<p>Dismantle and mounting tool set: 3HAC028920-001</p> <p>User instructions are enclosed with the tool.</p>
5	Fit the retaining ring.	 <p>xx1300000664</p>
6	Apply locking liquid on the screws and secure the shafts.	<p>Loctite 2400 (or equivalent Loctite 243)</p> <p>M16x70 12.9 Gleitmo 603+Geomet 500 (2 pcs)</p> <p>Tightening torque: 300 Nm±10%</p>  <p>xx1300000663</p>

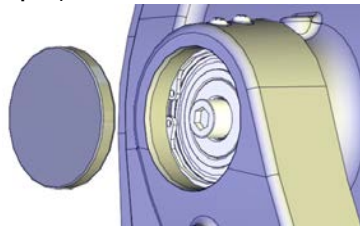
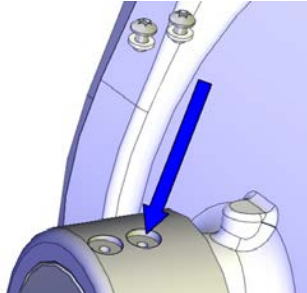
Continues on next page

	Action	Note
7	Fit new VK covers.	<p>VK cover, 100x10, 3HAA2166-13 (2 pcs)</p>  <p>xx1300000837</p>
8	Unscrew both screws in the cradle and fill the bearing with grease from the inner hole until grease appears in the outer hole.	<p>Shell Gadus S2: 3HAC042536-001</p>  <p>xx1300000832</p>
9	Refit the screws.	
10	Wipe clean from residual grease.	

Refitting the front shaft

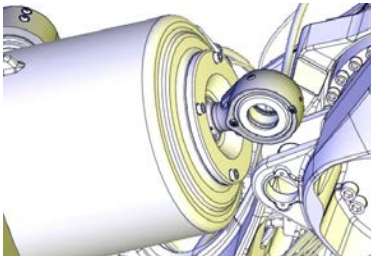



	Action	Note
1	 DANGER Turn off all: <ul style="list-style-type: none"> • electric power supply • hydraulic pressure supply • air pressure supply to the robot, before entering the safeguarded space.	
2	Remove all residues of Loctite in the screw hole of the shaft.	
3	Wipe all contact surfaces inside the recess clean from residual grease or other contamination.	
4	Align the balancing device link ear with the hole in the lower arm.  Note Verify that the link ear is correctly turned.	 <p>xx1300000784</p>

Continues on next page

4 Repair

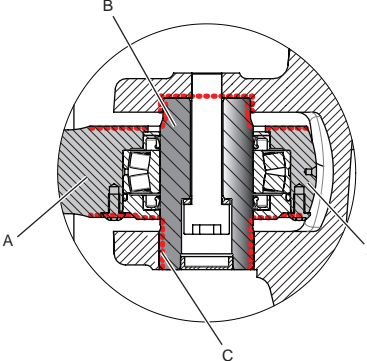
4.6.2 Replacing the balancing device

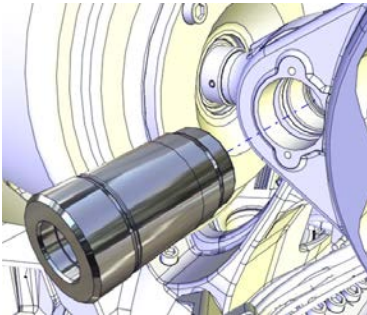
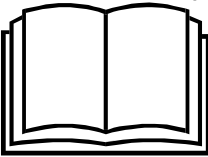
Continued

	Action	Note
5	<p>Foundry Plus: Apply Mercasol on the surfaces on the shaft and front ear.</p>	 <p>xx1400000368</p> <p>A Front link ear B Shaft C Mercasol (red dotted lines)</p>
6	<p>Lubricate the shaft and place it to the front ear.</p> <p> Note</p> <p>Foundry Plus: Do not lubricate surfaces where Mercasol is applied.</p>	 <p>xx1200001280</p>
7	<p>Press in the shaft using the dismantle and mounting tool, according to user instructions enclosed with the equipment.</p>  <p>xx0900000813</p> <p>Go to the user instructions enclosed with the press tool.</p> <p> DANGER</p> <p>Handling the tool incorrectly will cause serious injury. Read and follow enclosed user instructions for the tool.</p>	<p>Dismantle and mounting tool set: 3HAC028920-001 User instructions are enclosed with the tool.</p>

Continues on next page

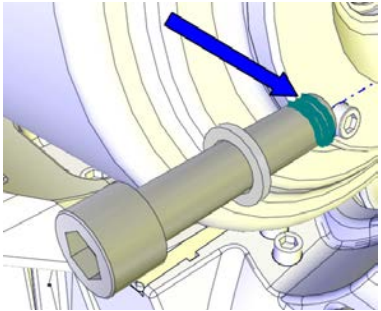
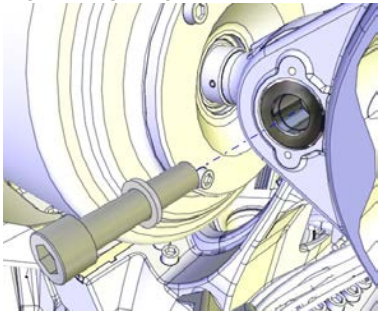
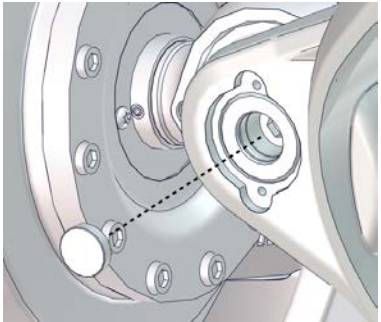
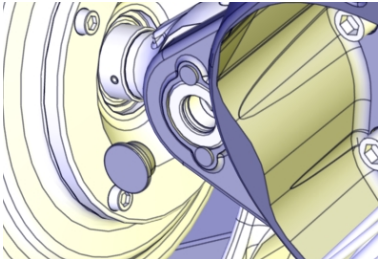
	Action	Note
8	Apply locking liquid on the first threads of the screw.	<p>Loctite 2701</p>  <p>xx1300000782</p>
9	Secure the shaft with screw and washer.	<p>Tightening torque: 180 Nm</p>  <p>xx1200001279</p>
10	Fit the protection plug or a new VK-cover (depends on shaft version).	 <p>xx1700000088</p>  <p>xx1900002311</p>

Continues on next page



4 Repair

4.6.2 Replacing the balancing device

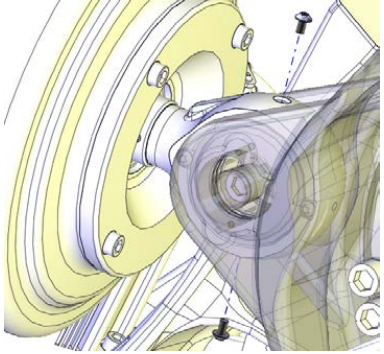

Continued

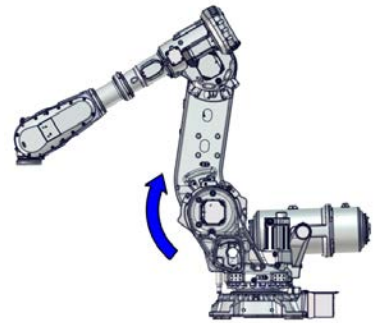
	Action	Note
11	Unscrew both screws in link ear. Fill the bearing with grease from the upper hole, until the grease appears in the lower hole.	Bearing grease: 3HAC042536-001  xx1300000783
12	Refit the two screws and wipe clean from residual grease.	
13	Refit the DressPack bracket, if used.	

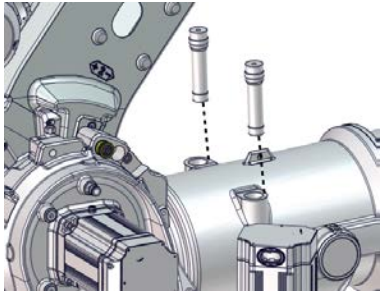
Restoring the balancing device

	Action	Note
1	Remove the lifting equipment from the balancing device.	
2	Jog axis 2 to -4° to be able to remove the relief screws.	 xx1700001406
3	Remove the relief screws to activate the balancing device.  Note Axis 2 must be in -4° .	 xx1700000070

Continues on next page

	Action	Note
4	<p>Refit the covers. Make sure that the o-rings are still fitted.</p> <p> Note</p> <p>Only manual force is required, no tightening torque.</p>	 <p>xx170000451</p>

Securing the lower arm

Use this procedure to secure the lower arm before lifting the robot to inverted position.

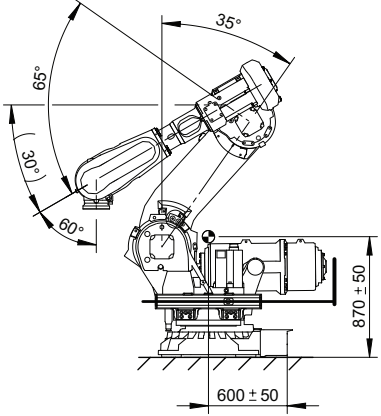
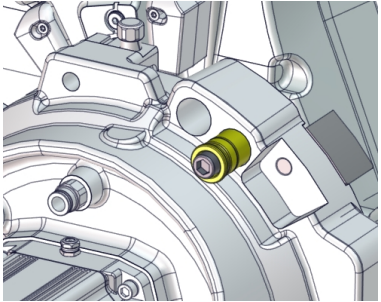
	Action	Note
1	<p>Verify that the robot stands in position:</p> <ul style="list-style-type: none"> • Axis 1: 0° • Axis 2: -35° • Axis 3: +65° • Axis 4: 0° • Axis 5: +60° • Axis 6: no significance 	 <p>xx1600001371</p>
2	<p>Remove the transportation lock screw and the yellow sleeve from the parking position.</p>	 <p>xx1700000348</p>

Continues on next page

4 Repair

4.6.2 Replacing the balancing device

Continued

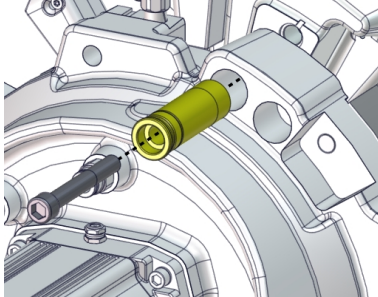
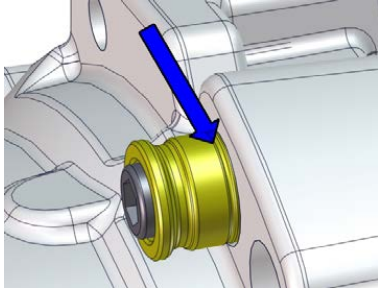
	Action	Note
3	<p>Insert the yellow sleeve and the transportation lock screw in the hole at the locking position. Insert the sleeve all the way so that the marking in the sleeve is aligned with the casting, see figure. Tighten the screw.</p> <p> DANGER</p> <p>Always use the transportation lock screw and sleeve to lock the lower arm at transportation, turning and floor standing.</p>	<p>Tightening torque: 70 Nm \pm15 Nm.</p>  <p>xx1700000347</p>  <p>xx1600002114</p>

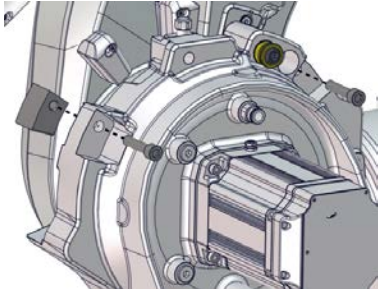
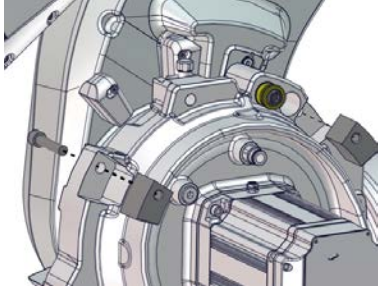

Preparations before lifting up the robot to inverted position

	Action	Note
1	Remove the two service stops from maintenance position, if previously moved there.	 <p>xx1700000068</p>
2	Fit the service stops in their parking position.	 <p>xx1700000067</p>
3	Fasten the fork lift accessory.	<p>See user instructions enclosed with the fork lift accessory.</p> <p>Fork lift accessory set: 3HAC058825-001.</p>

Continues on next page

	Action	Note
4	Remove the bolts securing the robot to the foundation.	

Orienting and securing the robot

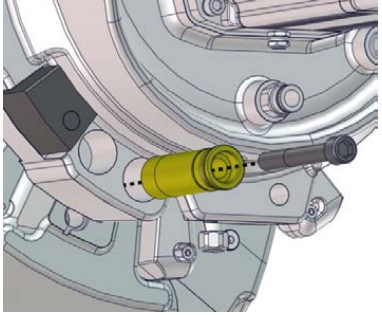
	Action	Note
1	Lift the robot using the fork lift accessory.	See user instructions enclosed with the fork lift accessory.
2	Move the robot close to its installation location.	
3	<p>Rotate the robot into inverted position using the turning tool or using a fork lift truck with a rotator attachment.</p> <p> DANGER</p> <p>Make sure that there is enough space underneath the robot. See user instructions for the turning tool.</p>	See user instructions enclosed with the turning tool.
4	Guide the robot using two M24 screws while lifting it into its mounting position.	
5	<p>Fit the bolts and washers in the base attachment holes.</p> <p> Note</p> <p>Lightly lubricate screws before assembly.</p> <p> CAUTION</p> <p>If high stress on screws are suspected, replace used screws with new ones.</p>	<p>Suitable screws, lightly lubricated: M24x100 (8 pcs), 8.8.</p> <p>Suitable washer: 4 mm flat washer.</p> <p>Screw tightening yield point utilization factor (v) (according to VDI2230): 90% (v=0.9).</p> <p>Tightening torque: 550 Nm (screws lubricated with Molykote 1000) 600-725 Nm, typical 650 Nm (screws none or lightly lubricated)</p>
6	Tighten bolts in a crosswise pattern to ensure that the base is not distorted.	
7	Remove the yellow sleeve and transportation lock screw from the transportation and turning position.	 <p>xx1700000269</p>

Continues on next page

4 Repair

4.6.2 Replacing the balancing device

Continued

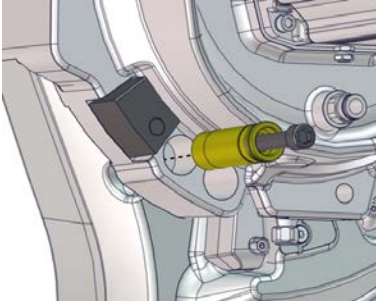
	Action	Note
8	Fasten the yellow sleeve and transportation lock screw in its parking position.	Tightening torque: 70 Nm \pm 15 Nm.  xx1700000270

4.6.3 Replacing the rear bearings on the balancing device

Location of the rear bearings

The rear bearings are located on each side of the balancing device.

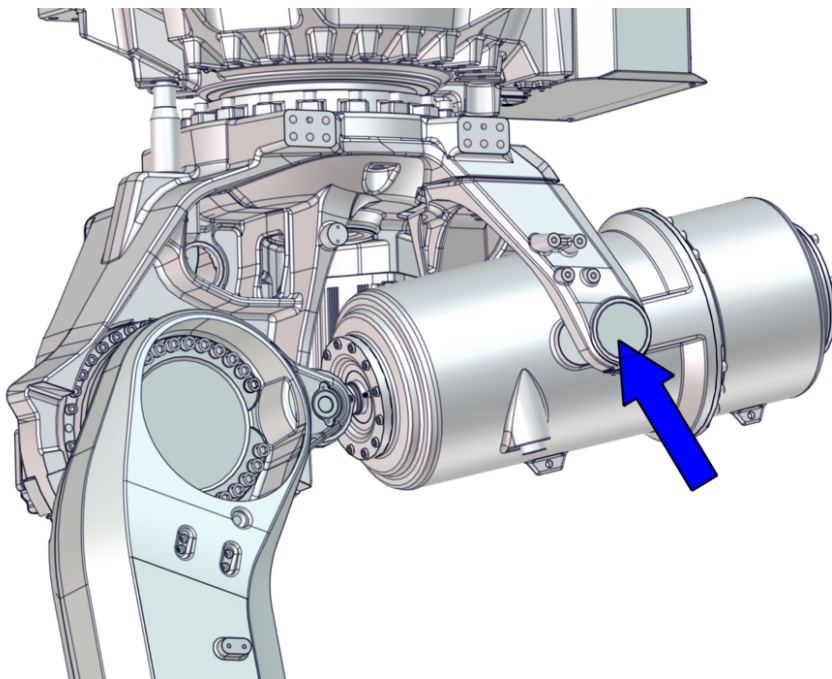

xx170000342

Summary of the replacement procedure

This is a brief summary of the replacement procedure, containing the major actions to be performed.

- 1 Lift down the robot to floor standing.
- 2 Unload the balancing device.
- 3 Replace the rear bearings.
- 4 Restore the balancing device.
- 5 Lift up and rotate the robot to inverted position.

Required spare parts



Note

The spare part numbers that are listed in the table can be out of date. See the latest spare parts of the IRB 6700Inv / IRB 6700I via myABB Business Portal, www.abb.com/myABB.

Spare part	Article number	Note
Maintenance kit, cradle	3HAC048834-001	The maintenance kit contains bearings, radial sealings, retaining rings, and VK covers.

Continues on next page

4 Repair

4.6.3 Replacing the rear bearings on the balancing device

Continued

Required tools and equipment

Equipment	Article number	Note
Relief screws	3HAC058129-001	Used for unloading the balancing device. Included in spare part balancing device.
Dismantle and mounting tool set	3HAC028920-001	Used for removing and fitting shaft and bearings.
Hydraulic cylinder	3HAC11731-1	To be used with the press tool.
Hydraulic pump 80 MPa	3HAC13086-1	To be used with the hydraulic cylinder.
Lifting shackle, 2 pcs	-	SA-10-8-NA1
Roundsling, 1 m	-	Lifting capacity: 1,000 kg.
Threaded bar, M16x340	-	
Press tool G	3HAC027146-001	Part of Dismantle and mounting tool set (3HAC028920-001).
Standard toolkit	-	Content is defined in section Standard toolkit on page 724 .

Required consumables

Consumable	Article number	Note
VK cover, 100x10 (2 pcs)	3HAA2166-13	Also included in the maintenance kit.
Bearing grease	3HAC042536-001	Shell Gadus S2
Locking liquid	-	Loctite 2400 (or equivalent Loctite 243)

Removing the rear bearings on the balancing device

Use these procedures to remove the rear bearings.

Securing the lower arm

Use this procedure to secure the lower arm.

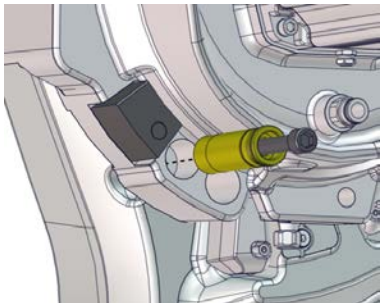
	Action	Note
1	Jog axis 2 to -35° .	
2	Remove the transportation lock screw and the yellow sleeve from the parking position.	 xx1700000270

Continues on next page

4.6.3 Replacing the rear bearings on the balancing device

Continued

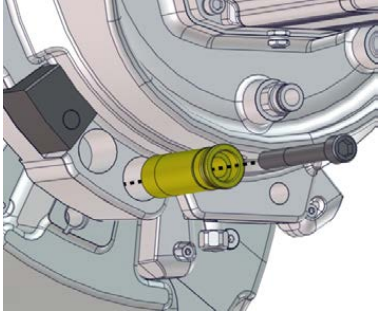
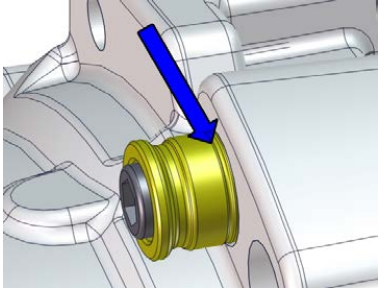
	Action	Note
3	<p>Insert the yellow sleeve and the transportation lock screw in the hole at the locking position. Insert the sleeve all the way so that the marking in the sleeve is aligned with the casting, see figure.</p> <p>Tighten the screw.</p> <p> DANGER</p> <p>Always use the transportation lock screw and sleeve to lock the lower arm at transportation, turning and floor standing.</p>	<p>Tightening torque: 70 Nm ±15 Nm.</p>  <p>xx1700000269</p>  <p>xx1600002114</p>

Lifting down the robot from inverted position

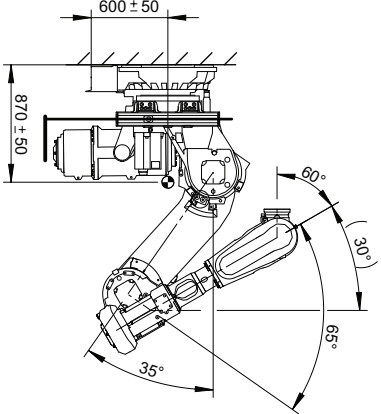

	Action	Note
1	<p> DANGER</p> <p>The robot must always be secured to the foundation if any kind of repair or maintenance work is to be performed.</p> <p>For some repair work support legs are required.</p>	<p>Suitable screws, lightly lubricated: M24x100 (min. 4 pcs)</p> <p>For hole configuration, see Hole configuration, base on page 66.</p>
2	<p>Verify that the lower arm is secured with the transportation lock screw.</p>	
3	<p>Remove any payload and tools from the robot.</p>	<p>DressPack can stay fitted.</p>
4	<p>Jog the robot into position:</p> <ul style="list-style-type: none"> • Axis 1: 0° • Axis 2: already in position and locked with the transportation lock screw, do not jog! • Axis 3: +65° • Axis 4: 0° • Axis 5: +60° • Axis 6: no significance 	 <p>xx1700000555</p>

Continues on next page

4 Repair

4.6.3 Replacing the rear bearings on the balancing device



Continued

	Action	Note
5	 DANGER Turn off all: <ul style="list-style-type: none">• electric power supply• hydraulic pressure supply• air pressure supply to the robot, before entering the safeguarded space.	
6	Disconnect the robot cables at the base.	
7	 CAUTION The weight of the IRB 6700Inv / IRB 6700I robot is 1,750 kg All lifting accessories used must be sized accordingly.	
8	Install the fork lift pockets to the robot.  DANGER Handling the tool incorrectly will cause serious injury. Read and follow enclosed user instructions for the tool.	See user instructions enclosed with the fork lift accessory set. Fork lift accessory set: 3HAC058825-001.

Continues on next page

4.6.3 Replacing the rear bearings on the balancing device

Continued

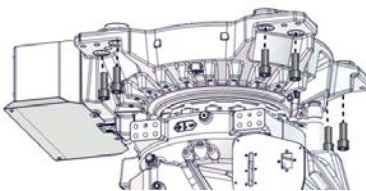
	Action	Note
9	<p>Choose one of the following lifting methods:</p> <ul style="list-style-type: none"> Lifting and turning with the fork lift (rotator attachment required): <ol style="list-style-type: none"> 1 Insert the forks of the fork lift truck into the fork lift pockets, as far as possible. 2 Raise the forks of the fork lift truck to make sure that the weight of the robot rests on the forks. <p> Tip</p> <p>Two M16 screws can be fitted to the fork lift pockets, to press the forks against the pockets and make the lift more stable.</p> Lifting and turning with the turning tool and overhead crane: <ol style="list-style-type: none"> 1 Install and use the turning tool according to enclosed user instructions. <p> DANGER</p> <p>Handling the tool incorrectly will cause serious injury.</p> <p>Read and follow enclosed user instructions for the tool.</p> 	<p>See user instructions enclosed with the turning tool.</p> <p>Turning tool: 3HAC073537-001.</p>
10	Remove the bolts that secure the robot to the foundation.	<p>Quantity: 8 pcs.</p>  <p>xx1600002098</p>
11	Rotate the robot to floor standing position.	Follow the user instructions enclosed with the turning tool.
12	<p>Lower and secure the robot to the floor. (Or to support legs, if replacing the axis-1 gear-box.)</p> <p>The lifting accessories can be kept installed if they are not in the way for the upcoming service procedure.</p>	Attachment screws: M24x100 (min. 4 pcs required to perform service)

Unloading the balancing device



	Action	Note
1	Verify that the robot is secured to the foundation.	Attachment screws: M24x100 (8 pcs).

Continues on next page

4 Repair

4.6.3 Replacing the rear bearings on the balancing device

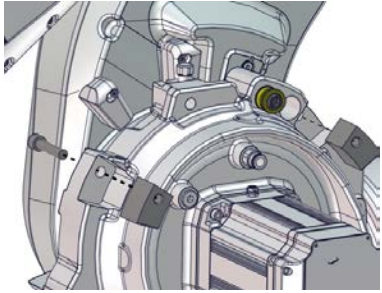
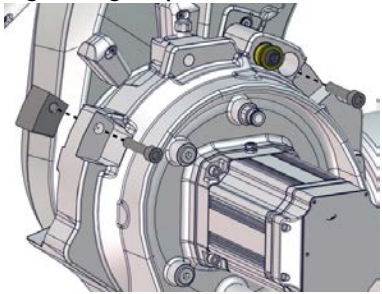

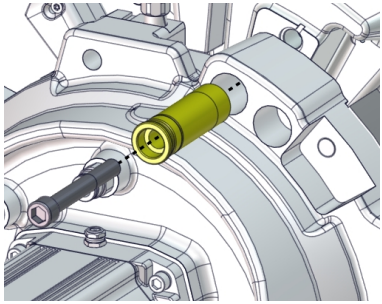
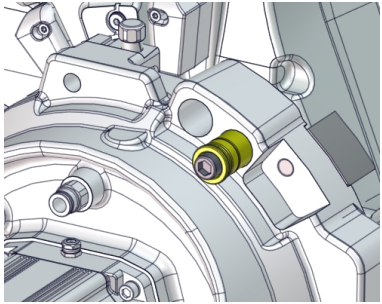

Continued

	Action	Note
2	Remove the two service stops from their parking position.	 xx170000067
3	Fit the service stops in maintenance position.	Tightening torque: 70 Nm \pm 15 Nm.  xx170000068
4	Remove the transportation lock screw and yellow sleeve from locking position.  Note It is only allowed to remove the transportation lock screw and sleeve, if the service stops are in maintenance position, when the robot is floor standing.	 xx1700000347
5	Fit the transportation lock screw and the yellow sleeve in their parking position.	 xx1700000348

Continues on next page

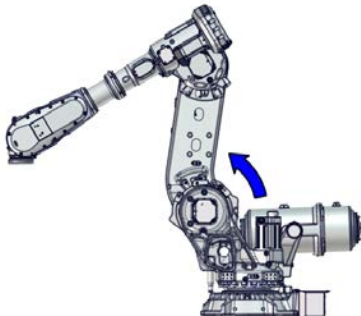
4.6.3 Replacing the rear bearings on the balancing device

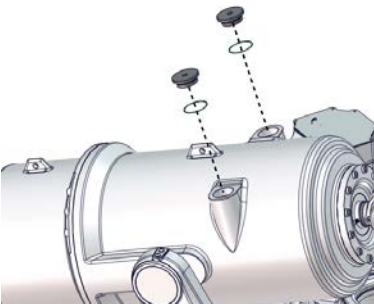
Continued

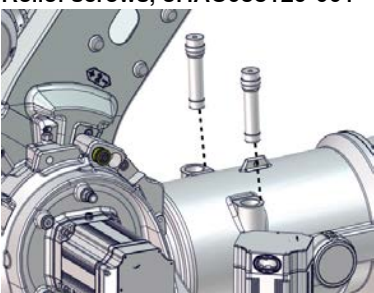
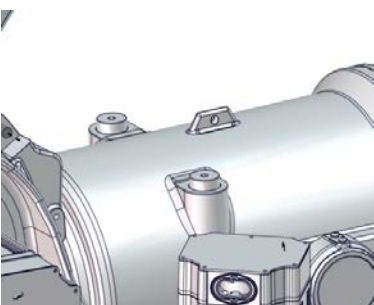

	Action	Note
6	<p>Jog axis 2 to -4° to be able to insert the relief screws.</p>	 <p>xx1700001404</p>
7	<p>Remove the covers on the balancing device.</p> <p> Note</p> <p>The covers have to be refitted after repair or maintenance.</p>	 <p>xx1700000451</p>
8	<p>Fit the relief screws to unload the balancing device.</p> <p> DANGER</p> <p>Do not remove the relief screws when the balancing device is removed from the robot.</p>	<p>Tightening torque: $70 \text{ Nm} \pm 15 \text{ Nm}$ Relief screws, 3HAC058129-001</p>  <p>xx1700000070</p>  <p>xx1700000560</p>

Continues on next page

4 Repair

4.6.3 Replacing the rear bearings on the balancing device

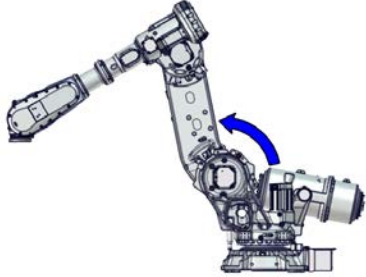
Continued

	Action	Note
9	Jog axis 2 to +15°.	 xx1700001405
10	 DANGER Turn off all: <ul style="list-style-type: none"> • electric power supply • hydraulic pressure supply • air pressure supply to the robot, before entering the safeguarded space.	

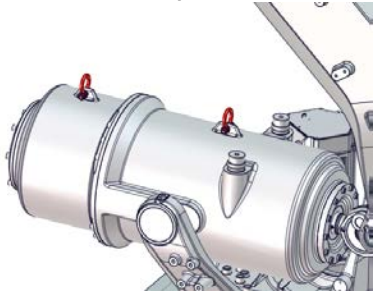

Attaching lifting accessories to the balancing device

	Action	Note
1	 CAUTION The weight of the balancing device (excluding cradle) is 305 kg All lifting accessories used must be sized accordingly.	
2	Fasten lifting shackles on the balancing device.	SA-10-8-NA1 (2 pcs)  xx1700000086

Continues on next page

4.6.3 Replacing the rear bearings on the balancing device

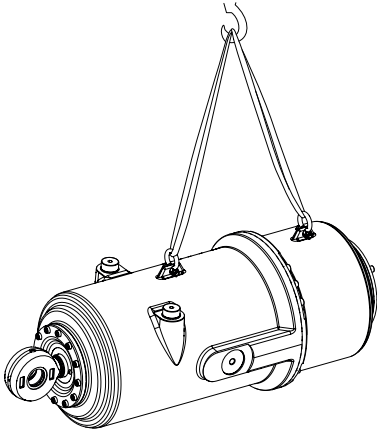
Continued

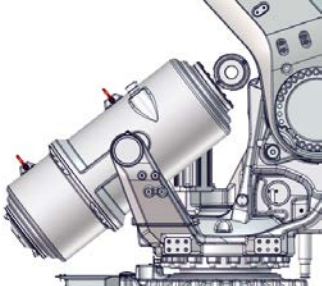
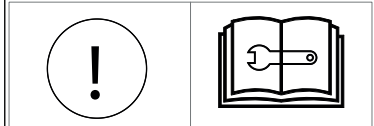
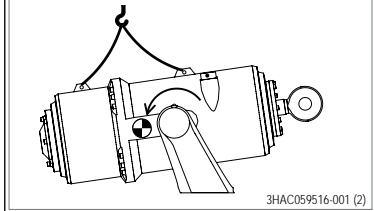
	Action	Note
3	Fasten the lifting slings.	<p>Roundsling, 1 m (2 pcs) Lifting capacity: 1,000 kg.</p>  <p>xx170000087</p>
4	<p>Raise the lifting slings to take the weight of the balancing device.</p> <p> CAUTION</p> <p>The balancing device is heavy at the back, and will tip over when the link ear is loosened.</p>  <p>xx1700000322</p>	  <p>3HAC059516-001 (2)</p> <p>xx1600002060</p>

Removing the shaft end and rear bearings



Note

Remove one shaft end and one bearing at a time.

Continues on next page

4 Repair

4.6.3 Replacing the rear bearings on the balancing device

Continued

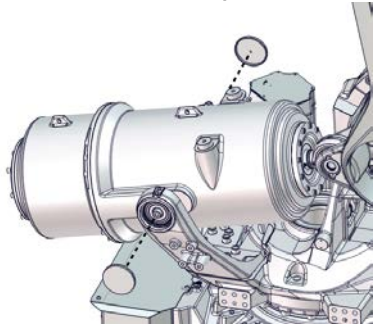
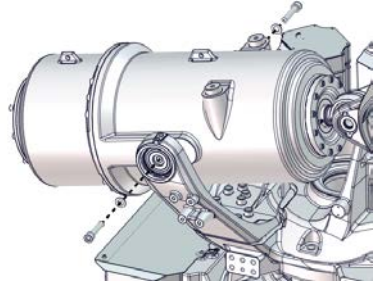
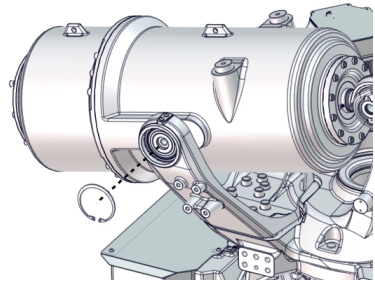
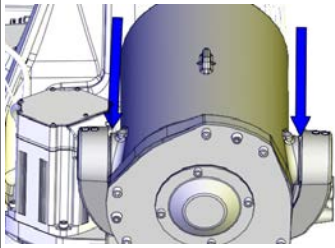
	Action	Note
1	<p>Remove the VK covers at the cradle.</p> <p> Tip</p> <p>Use high pressure air to remove the VK covers.</p>	<p>It is possible to drive a screwdriver (or similar) through the VK cover, as close as possible to the center of the VK cover and pull it out.</p>  <p>xx170000091</p>
2	<p>Wipe off all residual grease inside the recess.</p>	
3	<p>Remove attachment screws and washers.</p>	 <p>xx170000094</p>
4	<p>Remove the retaining ring bore.</p>	 <p>xx170000343</p>
5	<p>Put a big screw driver between the cradle and balancing device and use it as a distance tool.</p>	 <p>xx130000838</p>

Continues on next page

4.6.3 Replacing the rear bearings on the balancing device

Continued

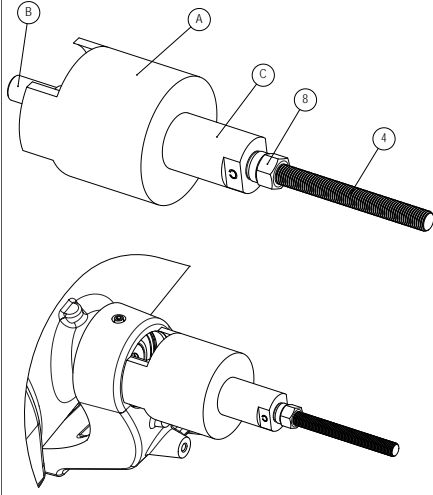
	Action	Note
6	<p>Apply the press tool and pull out the shaft end with the groove ball bearing.</p> 	<p>Dismantle and mounting tool set: 3HAC028920-001</p>

Refitting the rear bearings

Use these procedures to refit the bearings in the cradle.

Refitting the shaft end and rear bearings

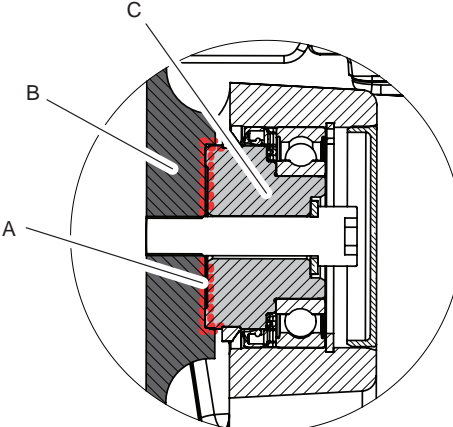

	Action	Note
1	<p>Wipe clean all contact surfaces from residual grease and other contamination inside the recess.</p>	
2	<p><i>Foundry Plus:</i> Apply Mercasol on matching surfaces on the axis and balancing device. See the figure.</p>	 <p>xx140000367</p> <p>A Mercasol (red dotted lines) B Balancing device C Shaft</p>

Continues on next page

4 Repair

4.6.3 Replacing the rear bearings on the balancing device

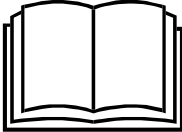
Continued

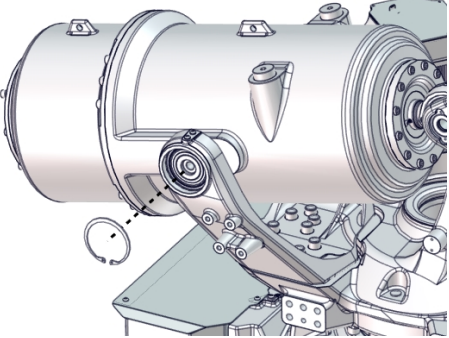
	Action	Note
3	<p>Apply some grease in the hole for the bearing in the cradle.</p> <p> Note</p> <p>Do not apply grease on surfaces with Mercasol.</p>	
4	<p>Apply a threaded bar into the hole in the balancing device using the dismantle and mounting tool, according to user instructions enclosed with the equipment.</p> <p></p> <p>xx0900000813</p> <p>Go to the user instructions enclosed with the press tool.</p> <p> DANGER</p> <p>Handling the tool incorrectly will cause serious injury. Read and follow enclosed user instructions for the tool.</p>	<p>Dismantle and mounting tool set: 3HAC028920-001</p> <p>User instructions are enclosed with the tool.</p>
5	<p>Fit the retaining ring bore.</p>	 <p>xx1700000343</p>
6	<p>Apply locking liquid on the attachment screw.</p>	<p>Loctite 2400 (or equivalent Loctite 243), -</p>



Continues on next page

4.6.3 Replacing the rear bearings on the balancing device

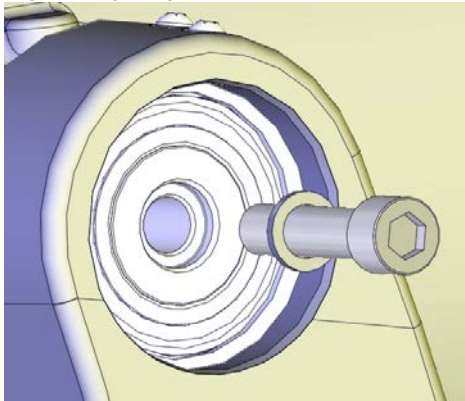
Continued

	Action	Note
7	While using the screw driver between the cradle and balancing device as a distance tool, tighten the attachment screw completely. Secure the balancing device.	Tightening torque: 300 Nm±10%.  xx130000663
8	Fit a VK cover to protect the bearing.	

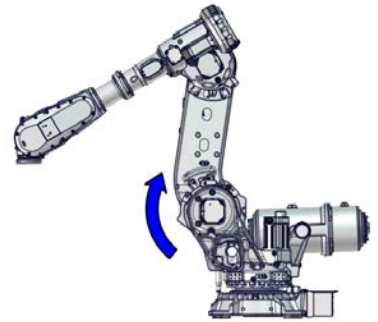
Restoring the balancing device

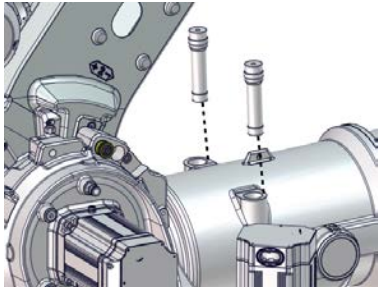
	Action	Note
1	Remove the lifting equipment from the balancing device.	
2	Jog axis 2 to -4° to be able to remove the relief screws.	 xx1700001406
3	Remove the relief screws to activate the balancing device.  Note Axis 2 must be in -4°.	 xx170000070

Continues on next page

4 Repair

4.6.3 Replacing the rear bearings on the balancing device

Continued

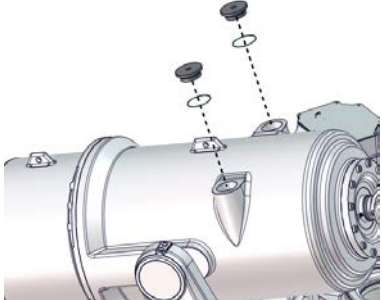
	Action	Note
4	<p>Refit the covers. Make sure that the o-rings are still fitted.</p> <p> Note</p> <p>Only manual force is required, no tightening torque.</p>	 <p>xx1700000451</p>

Securing the lower arm

Use this procedure to secure the lower arm before lifting the robot to inverted position.

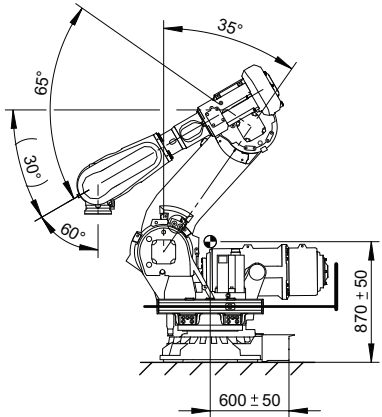
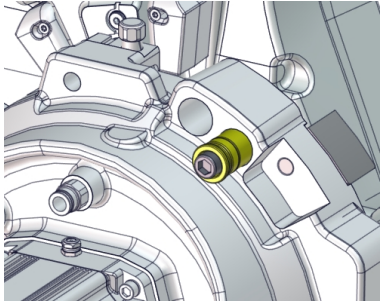
	Action	Note
1	<p>Verify that the robot stands in position:</p> <ul style="list-style-type: none"> • Axis 1: 0° • Axis 2: -35° • Axis 3: +65° • Axis 4: 0° • Axis 5: +60° • Axis 6: no significance 	 <p>xx1600001371</p>
2	<p>Remove the transportation lock screw and the yellow sleeve from the parking position.</p>	 <p>xx1700000348</p>

Continues on next page

4.6.3 Replacing the rear bearings on the balancing device

Continued

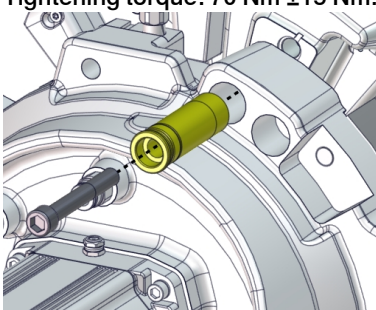
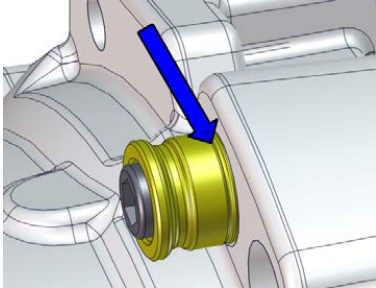
	Action	Note
3	<p>Insert the yellow sleeve and the transportation lock screw in the hole at the locking position. Insert the sleeve all the way so that the marking in the sleeve is aligned with the casting, see figure.</p> <p>Tighten the screw.</p>  <p>DANGER</p> <p>Always use the transportation lock screw and sleeve to lock the lower arm at transportation, turning and floor standing.</p>	<p>Tightening torque: 70 Nm ±15 Nm.</p>  <p>xx1700000347</p>  <p>xx1600002114</p>

Preparations before lifting up the robot to inverted position

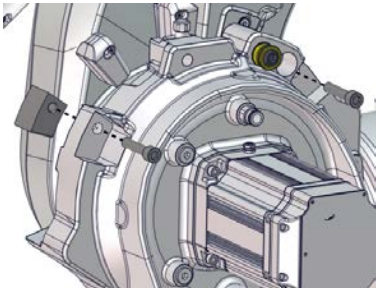
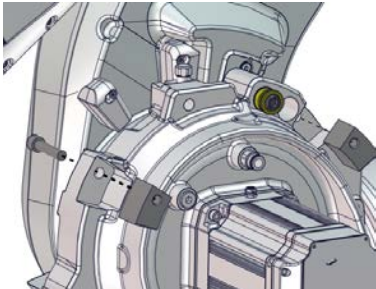
	Action	Note
1	<p>Remove the two service stops from maintenance position, if previously moved there.</p>	 <p>xx1700000068</p>
2	<p>Fit the service stops in their parking position.</p>	 <p>xx1700000067</p>
3	<p>Fasten the fork lift accessory.</p>	<p>See user instructions enclosed with the fork lift accessory.</p> <p>Fork lift accessory set: 3HAC058825-001.</p>

Continues on next page



4 Repair

4.6.3 Replacing the rear bearings on the balancing device

Continued

	Action	Note
4	Remove the bolts securing the robot to the foundation.	

Orienting and securing the robot

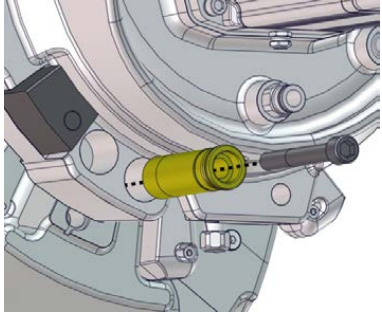
	Action	Note
1	Lift the robot using the fork lift accessory.	See user instructions enclosed with the fork lift accessory.
2	Move the robot close to its installation location.	
3	<p>Rotate the robot into inverted position using the turning tool or using a fork lift truck with a rotator attachment.</p> <p> DANGER</p> <p>Make sure that there is enough space underneath the robot. See user instructions for the turning tool.</p>	See user instructions enclosed with the turning tool.
4	Guide the robot using two M24 screws while lifting it into its mounting position.	
5	<p>Fit the bolts and washers in the base attachment holes.</p> <p> Note</p> <p>Lightly lubricate screws before assembly.</p> <p> CAUTION</p> <p>If high stress on screws are suspected, replace used screws with new ones.</p>	<p>Suitable screws, lightly lubricated: M24x100 (8 pcs), 8.8.</p> <p>Suitable washer: 4 mm flat washer.</p> <p>Screw tightening yield point utilization factor (v) (according to VDI2230): 90% (v=0.9).</p> <p>Tightening torque: 550 Nm (screws lubricated with Molykote 1000) 600-725 Nm, typical 650 Nm (screws none or lightly lubricated)</p>
6	Tighten bolts in a crosswise pattern to ensure that the base is not distorted.	
7	Remove the yellow sleeve and transportation lock screw from the transportation and turning position.	 <p>xx1700000269</p>

Continues on next page

4.6.3 Replacing the rear bearings on the balancing device

Continued

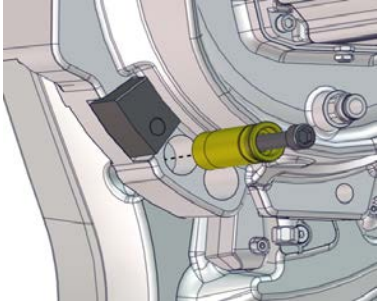
	Action	Note
8	Fasten the yellow sleeve and transportation lock screw in its parking position.	<p>Tightening torque: 70 Nm ±15 Nm.</p>  <p>xx1700000270</p>

4 Repair

4.6.4 Replacing the stop pin

4.6.4 Replacing the stop pin

Location of the stop pin

The stop pin is located as shown in the figure.

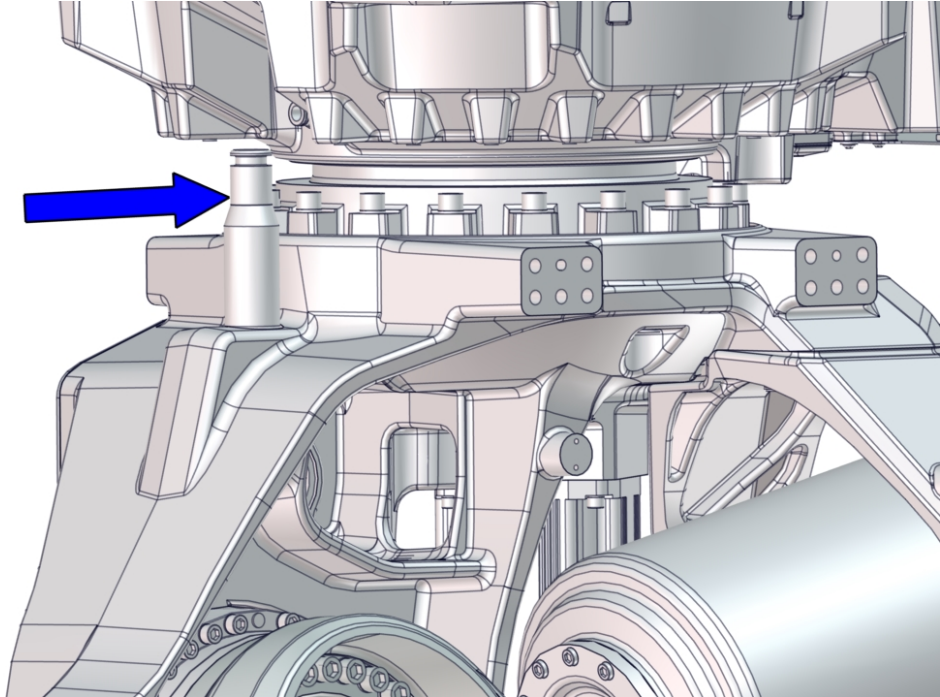

xx170000351

Spare part

Equipment	Article number	Note
Stop pin	See <i>Product manual, spare parts - IRB 6700/IRB 6700Inv</i>	

Required tools and equipment

Equipment, etc.	Article number	Note
Standard toolkit	-	Content is defined in section Standard toolkit on page 724 .

Required consumables

Consumable	Article number	Note
Locking liquid	-	Loctite 2400 (or equivalent Loctite 243)
<i>Foundry plus:</i> Rust preventive	3HAC034903-001	Mercasol 3110 Waxcoat. Recommended drying time is 24h.

Continues on next page

Removing the stop pin

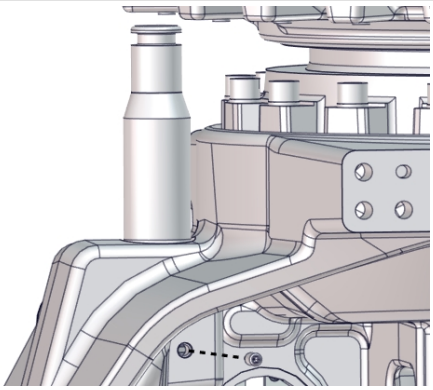
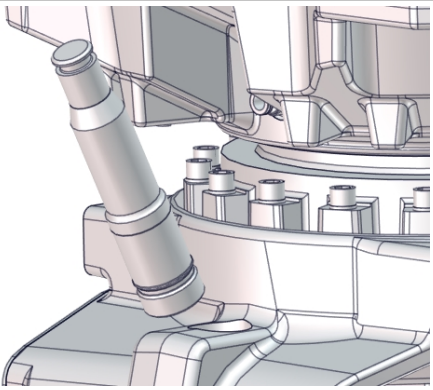
	Action	Note
1	<p> DANGER</p> <p>Turn off all:</p> <ul style="list-style-type: none"> • electric power supply • hydraulic pressure supply • air pressure supply <p>to the robot, before entering the robot working area.</p>	
2	<p>Hold the mechanical stop pin in a firm grip. Remove the set screw, cup point.</p>	 <p>xx170000356</p>
3	<p>Remove the stop pin.</p>	 <p>xx170000358</p>

Continues on next page

4 Repair

4.6.4 Replacing the stop pin

Continued

Refitting the stop pin

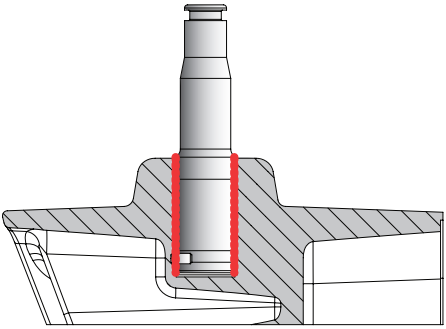
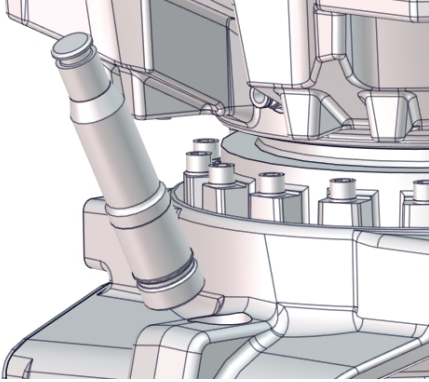
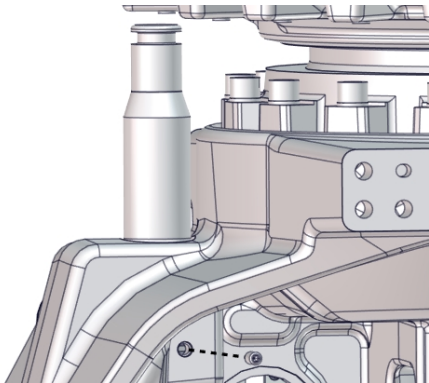
	Action	Note
1	<p><i>Foundry Plus:</i> Apply Mercasol on the surfaces shown in the figure, on stop pin and in the hole as shown in the figure.</p>	<p>Rust preventive: 3HAC034903-001 (Mercasol 3110 Waxcoat. Recommended drying time is 24h.).</p>  <p>xx170000414</p>
2	Fit the stop pin.	 <p>xx170000358</p>
3	Apply locking liquid on the set screw, and secure the stop pin.	<p>Loctite 2400 (or equivalent Loctite 243) Set screw: M10x20</p>  <p>xx170000356</p>

4.7 Motors

4.7.1 Replacing the axis-1 motor

Location of the axis-1 motor

The motor is located as shown in the figure.

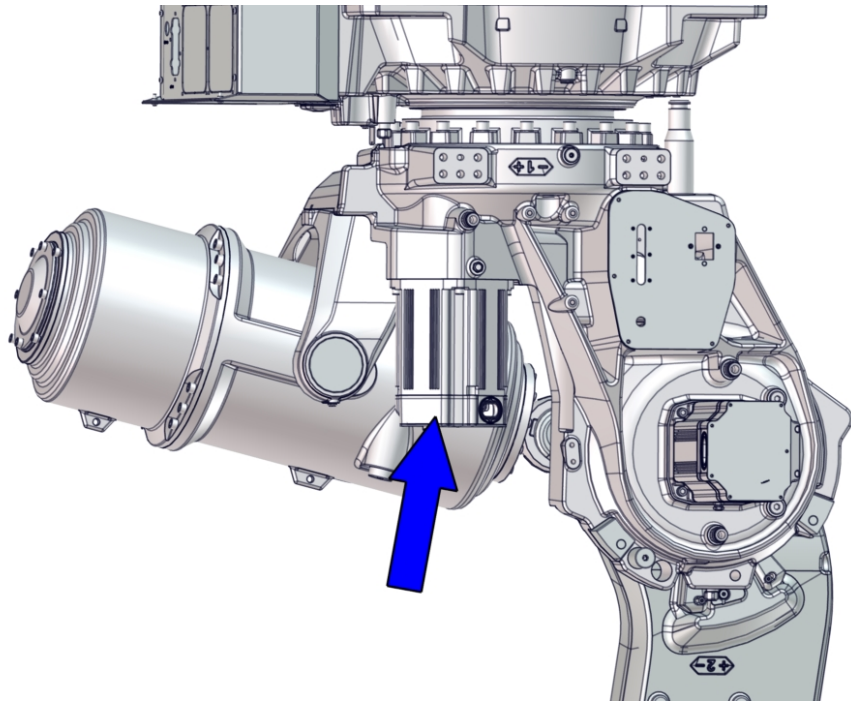

xx170000359

Summary of the replacement procedure

This list is a brief summary of the replacement procedure, containing the major actions to be performed.

- 1 Attach the lifting tools
- 2 Replace the motor
- 3 Remove the lifting tools.

Spare parts

Spare part	Spare part number	Note
Axis-1 motor	See <i>Product manual, spare parts - IRB 6700/IRB 6700Inv</i>	

Consumables

Equipment, etc.	Article number	Note
Grease	3HAC042536-001	Used to lubricate o-rings, Shell Gadus S2.

Continues on next page

4 Repair

4.7.1 Replacing the axis-1 motor

Continued

Equipment, etc.	Article number	Note
Grease	3HAC063069-001	Castrol Molub. Alloy 777-1 NG, 5 ml. To be used on hub splines to prevent from fretting corrosion.
O-ring	3HAC054692-002	D=169.5x3 Used on motor cover.
O-ring	3HAB3772-107	D=102x3 Used on motor flange.

Required tools and equipment

Equipment, etc.	Article number	Note
Removal tool axis-1 motor	3HAC062250-001	Used to lower and raise the motor axis-1 (inverted position).
Removal tool motor M12	3HAC14631-1	Used to push out the motor, if necessary. Always use removal tools in pairs.
Roundsling, 1 m	-	Lifting capacity: 1,000 kg.
Lifting eye, M12	3HAC16131-1	
Guide pin, M10x150	3HAC15521-2	Always use guide pins in pairs.
Bits extender	3HAC12342-1	300 mm, bits 1/2"
Rotation tool	3HAB7887-1	Used to rotate the motor pinion.
24 VDC power supply	-	Used to release the motor brakes.
Leak-down tester	-	
Calibration tool box, Axis Calibration	3HAC055412-001	Delivered as a set of calibration tools.
Standard toolkit	-	Content is defined in section Standard toolkit on page 724 .

Deciding calibration routine

Decide which calibration routine to be used, based on the information in the table. Depending on which routine is chosen, action might be required prior to beginning the repair work of the robot, see the table.

	Action	Note
1	Decide which calibration routine to use for calibrating the robot. <ul style="list-style-type: none">Reference calibration. External cable packages (DressPack) and tools can stay fitted on the robot.Fine calibration. All external cable packages (DressPack) and tools must be removed from the robot.	

Continues on next page

Action	Note
<p>If the robot is to be calibrated with reference calibration:</p> <p>Find previous reference values for the axis or create new reference values. These values are to be used after the repair procedure is completed, for calibration of the robot.</p> <p>If no previous reference values exist, and no new reference values can be created, then reference calibration is not possible.</p>	<p>Follow the instructions given in the reference calibration routine on the FlexPendant to create reference values.</p> <p>Creating new values requires possibility to move the robot.</p> <p>Read more about reference calibration for Axis Calibration in Reference calibration routine on page 695.</p>
<p>If the robot is to be calibrated with fine calibration:</p> <p>Remove all external cable packages (DressPack) and tools from the robot.</p>	

Removing the axis-1 motor

These procedures describe how to remove the motor.

Preparations before removing the axis-1 motor

Action	Note
1 Decide which calibration routine to use, and take actions accordingly prior to beginning the repair procedure.	
2 Jog the robot to the synchronization position.	
<p>3  DANGER</p> <p>Turn off all:</p> <ul style="list-style-type: none"> • electric power supply • hydraulic pressure supply • air pressure supply <p>to the robot, before entering the safeguarded space.</p>	

Disconnecting the motor cables

Action	Note
<p>1  DANGER</p> <p>Make sure that all supplies for electrical power, hydraulic pressure, and air pressure are turned off.</p>	

Continues on next page

4 Repair

4.7.1 Replacing the axis-1 motor

Continued

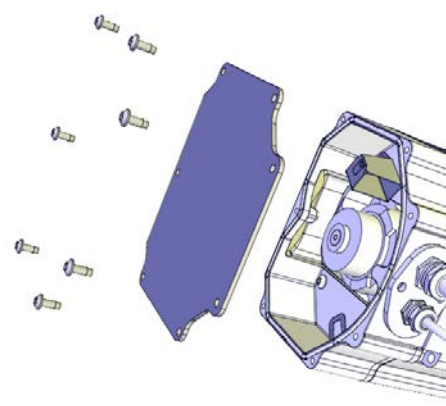
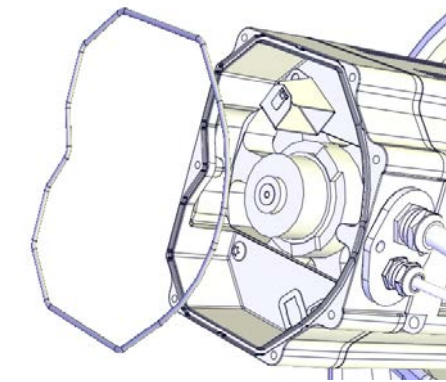
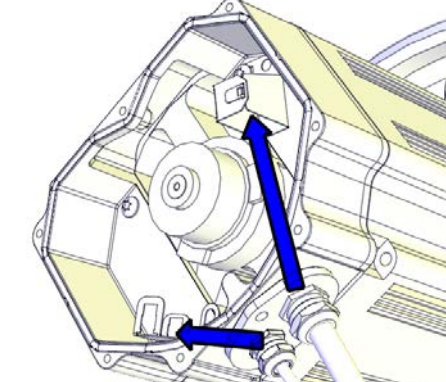
	Action	Note
2	Unscrew the attachment screws and washers and remove the motor cover.	 <p>xx1200001135</p>
3	Make sure the o-ring is present.	 <p>xx1200001070</p>
4	Disconnect the motor cables.	 <p>xx1200001066</p>

Continues on next page

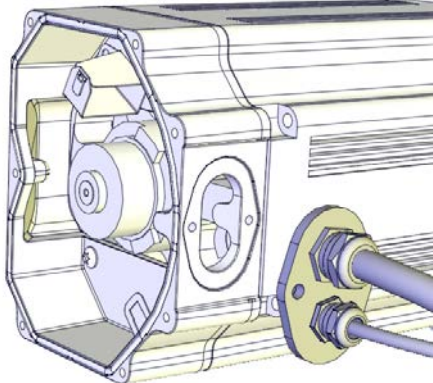
	Action	Note
5	<p>Remove the cable gland cover. Make sure the gasket is not damaged.</p> <p> Tip</p> <p>Make a note in which direction the cable gland hole is facing, if the motor will be removed too. The motor shall be refitted in the same position.</p>	 <p>xx1200001067</p>
6	Use caution and pull out the motor cables.	

Attaching the removal tool

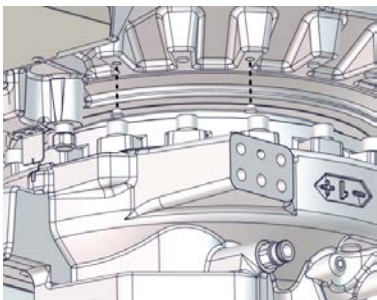
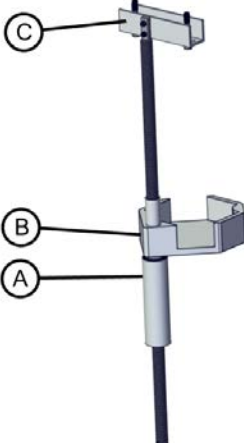
	Action	Note						
1	<p><i>Foundry plus:</i> Remove the plastic plugs.</p>	 <p>xx1700000364</p>						
2	<p>Lower the revolving handle on the removal tool, to be able to fit the shelf beneath the motor while fastening the tool.</p>	 <p>xx1700000365</p> <table border="1" data-bbox="1059 1805 1433 1939"> <tbody> <tr> <td>A</td> <td>Revolving handle</td> </tr> <tr> <td>B</td> <td>Shelf</td> </tr> <tr> <td>C</td> <td>Bracket</td> </tr> </tbody> </table>	A	Revolving handle	B	Shelf	C	Bracket
A	Revolving handle							
B	Shelf							
C	Bracket							

Continues on next page

4 Repair

4.7.1 Replacing the axis-1 motor

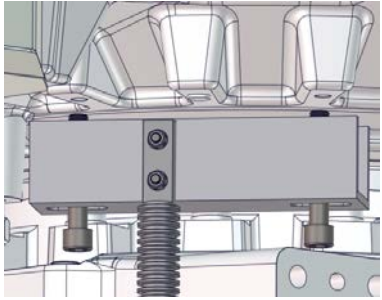

Continued

	Action	Note
3	Attach the tools bracket screws to the robot frame.	 xx1700000366

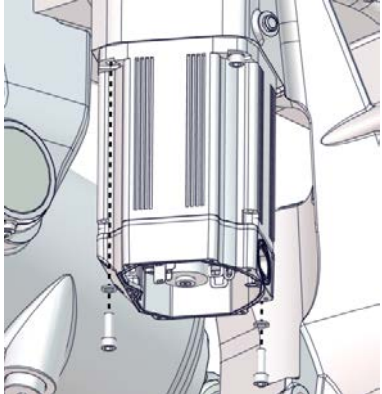
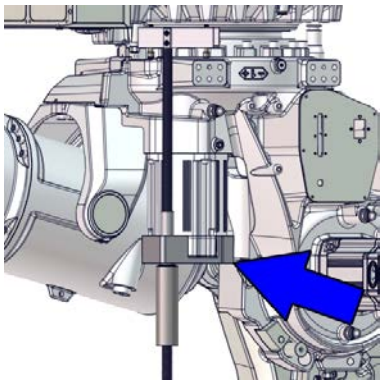
Removing the axis-1 motor

	Action	Note
1	Remove the two shown motor screws and washers.	Bits extender, 3HAC12342-1  xx1700000368
2	Raise the revolving handle to fit the motor on the tool shelf.	 xx1700000367

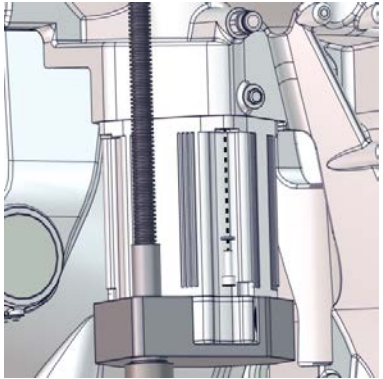
Continues on next page

	Action	Note
3	<p>Remove the two remaining screws holding the motor. (One screw is placed on the opposite side of the motor.)</p> <p> CAUTION</p> <p>Whenever parting/mating motor pinion and hub, the splines may be damaged if excessive force is used.</p>	<p>Bits extender, 3HAC12342-1</p>  <p>xx1700000369</p>
4	<p>To release the brakes, connect the 24 VDC power supply.</p> <p>Connect to R2.MP1-connector:</p> <ul style="list-style-type: none"> • + = pin 2 • - = pin 5 	24 VDC power supply
5	Lower the revolving handle.	If the motor is stuck, use Removal tool motor M12: 3HAC14631-1
6	<p>Rotate the shelf to remove the motor.</p> <p> CAUTION</p> <p>The weight of the motor is 27 kg All lifting accessories used must be sized accordingly.</p>	
7	Disconnect the 24 VDC power supply.	
8	Fasten lifting eyes in two of the fastening holes on the motor.	Lifting eye, M12, 3HAC16131-1
9	Use a roundsling to lift the motor off.	

Refitting the axis-1 motor

These procedures describes how to refit the motor.

Preparations prior to refitting motor



	Action	Note
1	<p> DANGER</p> <p>Make sure that all supplies for electrical power, hydraulic pressure, and air pressure are turned off.</p>	
2	<p>Remove any old paint residues or other contamination from the contact surfaces on both the motor and the mating parts.</p> <p>Wipe clean the contact surfaces and the o-ring groove.</p>	

Continues on next page

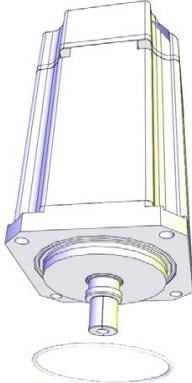

4 Repair

4.7.1 Replacing the axis-1 motor

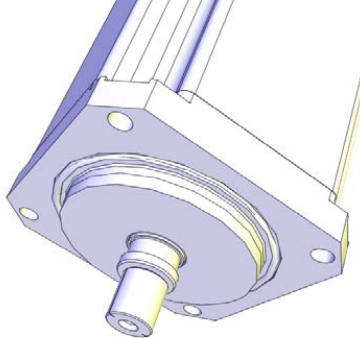
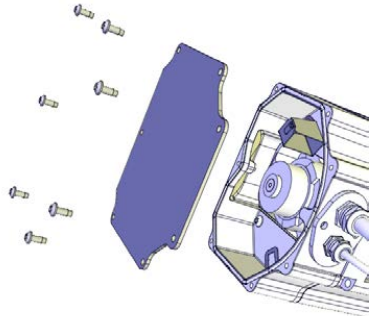
Continued

	Action	Note
3	Fit a new o-ring.	 <p>xx1200001019</p>
4	<p>Make sure the o-ring is seated in the groove.</p> <p> Tip</p> <p>Lubricate the o-ring with some grease for a better fitting in the groove.</p>	 <p>xx1200001020</p>
5	If the motor is a new spare part, remove the cover.	 <p>xx1200001135</p>

Continues on next page

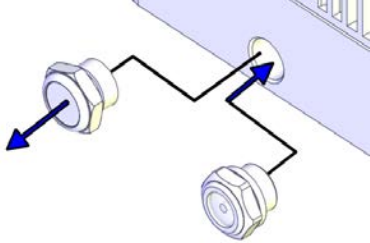
	Action	Note
6	<p>Protection type Foundry Plus Valid for axis-2, axis-3, axis-4 and axis-6 motors. If the motor is a new spare part, the evacuation hole protection filter must be replaced with a transparent plug/sight glass (enclosed with the spare part delivery). Remove the protection filter and install the transparent plug/sight glass. On the axis-6 motor there are two protection filters that must be replaced with transparent plugs/sight glasses.</p> <div style="display: flex; justify-content: space-around;"> <div data-bbox="515 607 788 831">  <p>xx2200002188</p> <p>Transparent plug (Foundry Plus).</p> </div> <div data-bbox="794 607 1043 831">  <p>xx1800000101</p> <p>Protection filter (Standard).</p> </div> </div>	<p>Tightening torque, transparent plug: 20 Nm \pm10% Tightening torque, protection filter: 10 Nm \pm10%</p>  <p>xx1600000576</p>

Attaching the removal tool

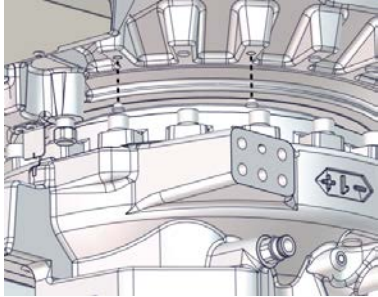
	Action	Note
1	<p>Foundry plus: Remove the plastic plugs.</p>	 <p>xx1700000364</p>

4 Repair

4.7.1 Replacing the axis-1 motor

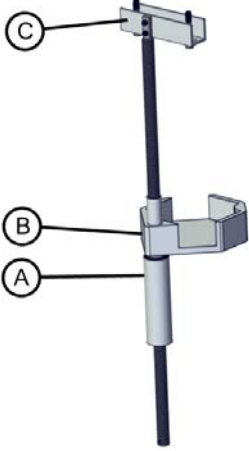
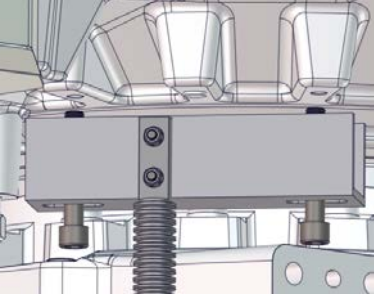

Continued

	Action	Note						
2	Lower the revolving handle on the removal tool, to be able to fit the shelf beneath the motor while fastening the tool.	 <p>xx170000365</p> <table border="1" data-bbox="1031 819 1406 958"> <tr> <td>A</td> <td>Revolving handle</td> </tr> <tr> <td>B</td> <td>Shelf</td> </tr> <tr> <td>C</td> <td>Bracket</td> </tr> </table>	A	Revolving handle	B	Shelf	C	Bracket
A	Revolving handle							
B	Shelf							
C	Bracket							
3	Attach the tools bracket screws to the robot frame.	 <p>xx170000366</p>						

Securing the axis-1 motor

	Action	Note
1	 CAUTION The weight of the motor is 27 kg All lifting accessories used must be sized accordingly.	
2	Fasten lifting eyes in two of the fastening holes on the motor.	Lifting eye, M12, 3HAC16131-1
3	Use a roundsling to lift the motor.	

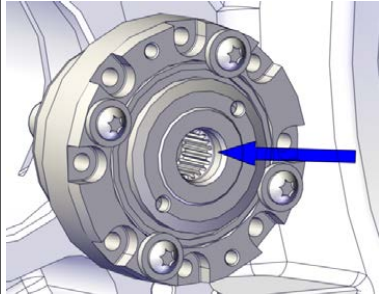
Continues on next page

	Action	Note
4	<p>Connect the 24 VDC power supply to release the brakes.</p> <p>Connect to R2.MP1-connector:</p> <ul style="list-style-type: none"> • + = pin 2 • - = pin 5 <p> Note</p> <p>Put the cables to the brake release tool through the hole in the tool shelf.</p>	
5	Fit guide pins in opposite holes.	<p>Guide pin, M10x150: 3HAC15521-2</p> <p>Always use guide pins in pairs.</p>
6	Apply 3 gram grease on the splines before fitting.	<p>Grease: Castrol Molub. Alloy 777-1 NG</p>  <p>xx1500002346</p>
7	Put the motor on the tool shelf and rotate it into position.	
8	<p> CAUTION</p> <p>Whenever parting/mating motor pinion and hub, the splines may be damaged if excessive force is used.</p>	
9	<p>Raise the revolving handle to assemble motor.</p> <ul style="list-style-type: none"> • Make sure that the motor pinion is properly mated into the hub. • Make sure that the motor pinion does not get damaged. • Make sure that the direction of the cable exit is facing the correct way. 	
10	<p>Secure the motor with its attachment screws and washers.</p> <p>Use a bits extender to reach the screws.</p>	<p>Bits extender: 3HAC12342-1</p> <p>Tightening torque: 50 Nm.</p> <p>Screw dimension : M10x40 quality 12.9 Gleitmo (4 pcs)</p>
11	Perform a leak-down test (if not already done).	See Performing a leak-down test on page 188 .
12	Disconnect the 24 VDC power supply.	

Continues on next page

4 Repair

4.7.1 Replacing the axis-1 motor

Continued

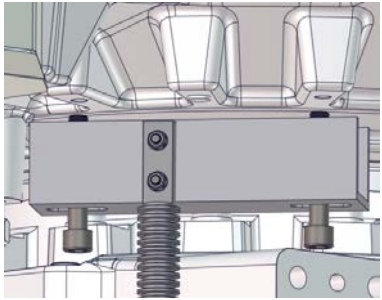
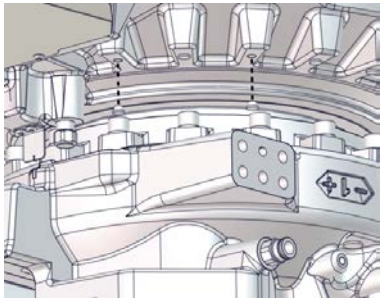

Removing the removal tool

	Action	Note
1	Remove screws holding the tool bracket.	 xx1700000366
2	<i>Foundry plus:</i> Refit the plastic plugs.	 xx1700000364

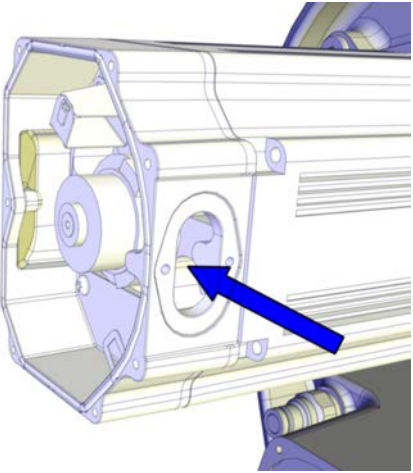
Connecting the motor cables

	Action	Note
1	Push the motor cables through the cable gland opening.	 xx1300000738

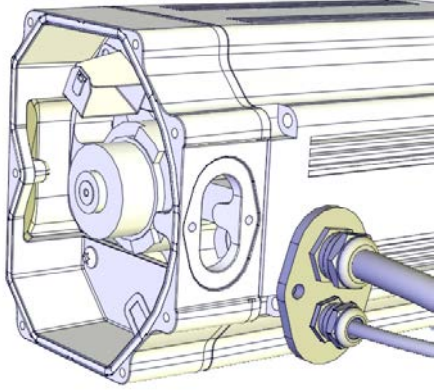
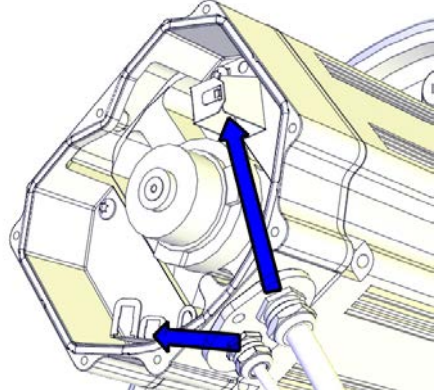
Continues on next page

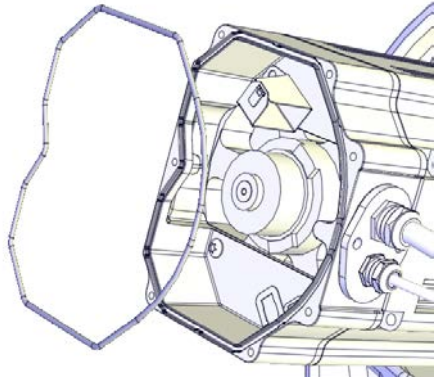



	Action	Note
2	<p>Refit the cable gland cover.</p> <p> Note Replace the gasket if damaged.</p>	 <p>xx1200001067</p>
3	<p>Connect the motor cables. Connect in accordance with the markings on the connectors.</p>	 <p>xx1200001066</p>
4	<p>Inspect the o-ring.</p> <p> Note Replace if damaged.</p>	<p>O-ring, axis-1: 3HAC054692-002 O-ring, axis-2: 3HAC054692-002 O-ring, axis-3: 3HAC054692-002 O-ring, axis-4: 3HAC054692-001</p>  <p>xx1200001070</p>
5	<p>Wipe clean o-ring and o-ring groove.</p>	

Continues on next page

4 Repair

4.7.1 Replacing the axis-1 motor

Continued

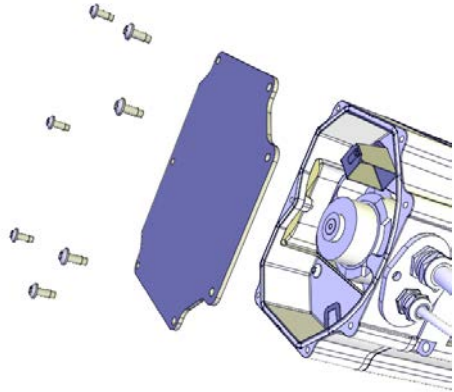
	Action	Note
6	Refit the o-ring.  Tip Lubricate the o-ring with some grease for a better fitting in the groove.	
7	 CAUTION When fitting the motor cover, make sure that none of the cables inside will be damaged.	
8	Refit the motor cover with it's attachment screws.  Note Do not reuse the self-threading attachment screws. Replace with standard attachment screws or the threads will be damaged.  Note Make sure the o-ring is undamaged and properly fitted.	Attachment screws: M5x12 8.8 (7 pcs)  xx1200001135
9	Make sure that the covers are tightly sealed.	

Concluding procedure

Use this procedure for the concluding refitting.

	Action	Note
1	Re-calibrate the robot.	Axis Calibration is described in Calibrating with Axis Calibration method on page 694 . General calibration information is included in section Calibration on page 683 .
2	 DANGER Make sure all safety requirements are met when performing the first test run. See Test run after installation, maintenance, or repair on page 97 .	

4.7.2 Replacing the axis-2 motor

Location of the motor

The motor is located as shown in the figure.

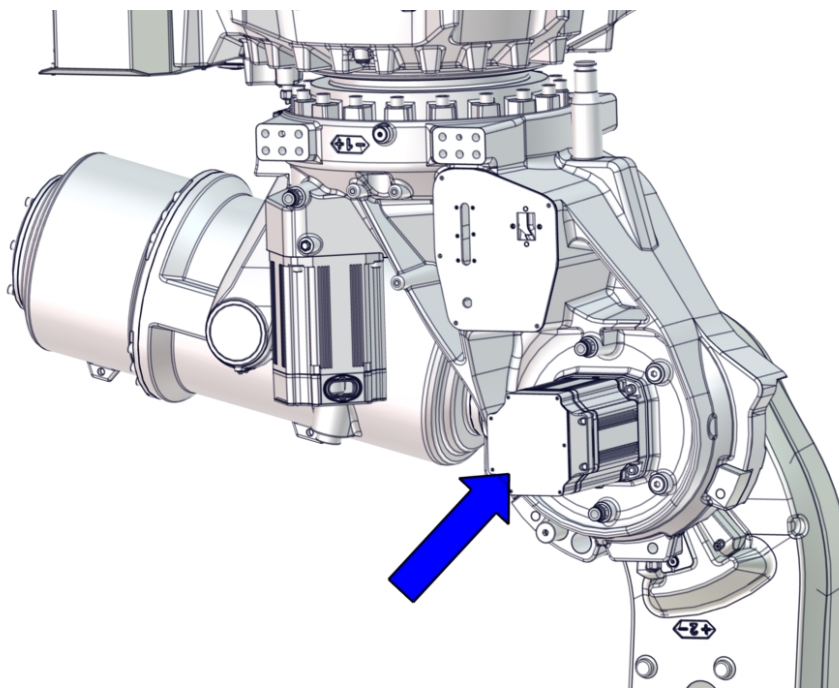

xx170000511

Summary of the replacement procedure

This list is a brief summary of the replacement procedure, containing the major actions to be performed.

- 1 Drain the axis-2 gearbox
- 2 Attach the lifting tools
- 3 Replace the motor
- 4 Remove the lifting tools
- 5 Refill the axis-2 gearbox with oil.

Spare parts

Spare part	Spare part number	Note
Axis-2 motor	See <i>Product manual, spare parts - IRB 6700/IRB 6700Inv</i>	

Consumables

Equipment, etc.	Article number	Note
Grease	3HAC042536-001	Shell Gadus S2 Used to lubricate o-rings.
Rust preventive	3HAC034903-001	Mercasol 3110 Waxcoat. Recommended drying time is 24h.

Continues on next page

4 Repair

4.7.2 Replacing the axis-2 motor

Continued

Equipment, etc.	Article number	Note
O-ring	3HAC054692-002	D=169.5x3 Used on motor cover.
O-ring	3HAB3772-107	D=102x3 Used on motor flange.

Required tools and equipment

Equipment, etc.	Article number	Note
Lifting accessory, motor	3HAC15534-1	Lifting instruction 3HAC15640-2 enclosed.
Roundsling, 1 m	-	Lifting capacity: 1,000 kg.
Removal tool motor M12	3HAC14631-1	Used to push out the motor, if necessary. Always use removal tools in pairs.
Guide pin, M10x150	3HAC15521-2	Always use guide pins in pairs.
Bits extender	3HAC12342-1	300 mm, bits 1/2"
Rotation tool	3HAB7887-1	Used to rotate the motor pinion.
24 VDC power supply	-	Used to release the motor brakes.
Lock screw, M16x120	-	Used to secure lower arm.
Leak-down tester	-	
Calibration tool box, Axis Calibration	3HAC055412-001	Delivered as a set of calibration tools.
Standard toolkit	-	Content is defined in section Standard toolkit on page 724 .

Deciding calibration routine

Decide which calibration routine to be used, based on the information in the table. Depending on which routine is chosen, action might be required prior to beginning the repair work of the robot, see the table.

	Action	Note
1	Decide which calibration routine to use for calibrating the robot. <ul style="list-style-type: none"> Reference calibration. External cable packages (DressPack) and tools can stay fitted on the robot. Fine calibration. All external cable packages (DressPack) and tools must be removed from the robot. 	
	<p>If the robot is to be calibrated with reference calibration:</p> <p>Find previous reference values for the axis or create new reference values. These values are to be used after the repair procedure is completed, for calibration of the robot.</p> <p>If no previous reference values exist, and no new reference values can be created, then reference calibration is not possible.</p>	<p>Follow the instructions given in the reference calibration routine on the FlexPendant to create reference values.</p> <p>Creating new values requires possibility to move the robot.</p> <p>Read more about reference calibration for Axis Calibration in Reference calibration routine on page 695.</p>





Continues on next page

Action	Note
<p>If the robot is to be calibrated with fine calibration: Remove all external cable packages (DressPack) and tools from the robot.</p>	

Removing the motor

These procedures describes how to remove the motor.

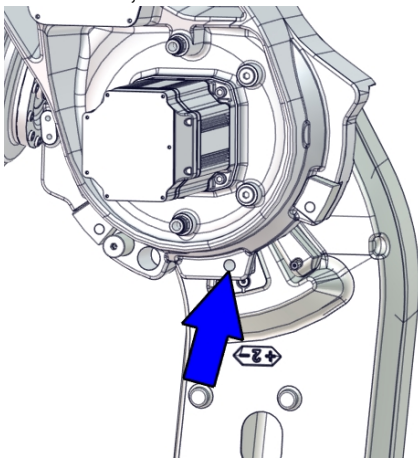
Preparations before removing the axis-2 motor

Action	Note
1	Decide which calibration routine to use, and take actions accordingly prior to beginning the repair procedure.
2	Drain the oil from the gearbox. See <i>Draining the axis-2 gearbox on page 157.</i>
3	Jog the robot to the calibration position.
4	<p> DANGER</p> <p>Secure the weight of the lower arm with a lock screw, before releasing the brakes on the axis-2 motor as well as before removing the axis-2 motor or the axis-2 gearbox.</p>
5	<p>Insert the lock screw into the frame. If needed, adjust the position of axis-2 to make it possible to insert the lock screw. The lock screw is used to secure the weight of the lower arm, in order to avoid accidents or damage.</p> <p> Note</p> <p>Tighten the lock screw manually, no tools needed.</p> <div style="text-align: right;"> <p>Lock screw, M16x120</p>  <p>xx1700000513</p> </div>
6	<p> DANGER</p> <p>Turn off all:</p> <ul style="list-style-type: none"> • electric power supply • hydraulic pressure supply • air pressure supply <p>to the robot, before entering the safe-guarded space.</p>

Continues on next page

4 Repair

4.7.2 Replacing the axis-2 motor



Continued

	Action	Note
7	Remove any equipment hindering access to the motor.	

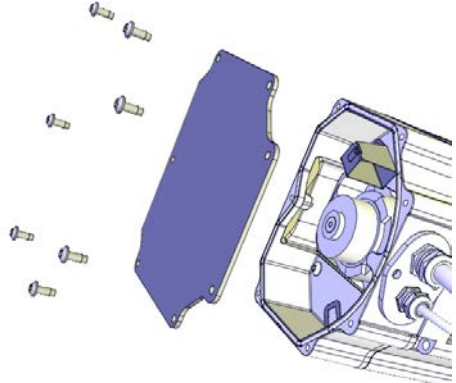
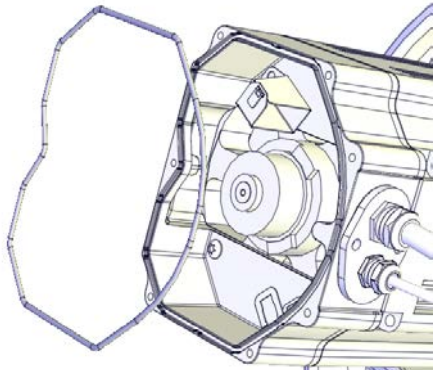
Disconnecting the motor cables

	Action	Note
1	 DANGER Make sure that all supplies for electrical power, hydraulic pressure, and air pressure are turned off.	
2	Unscrew the attachment screws and washers and remove the motor cover.	 xx1200001135
3	Make sure the o-ring is present.	 xx1200001070

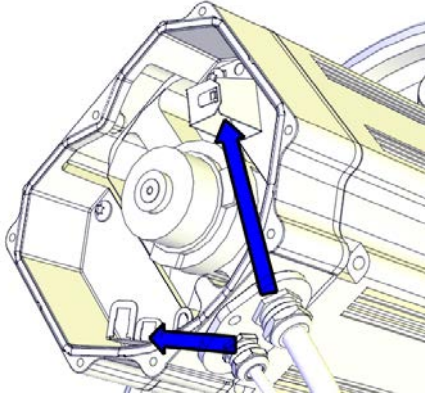
Continues on next page

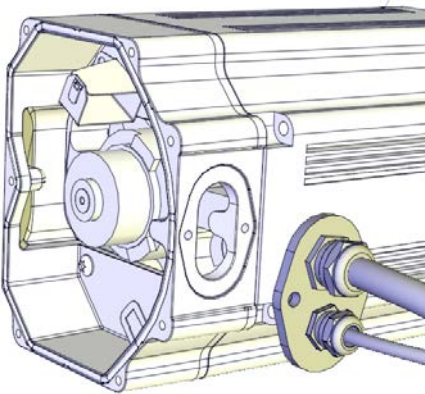
	Action	Note
4	Disconnect the motor cables.	 <p>xx1200001066</p>
5	Remove the cable gland cover. Make sure the gasket is not damaged.  Tip Make a note in which direction the cable gland hole is facing, if the motor will be removed too. The motor shall be refitted in the same position.	 <p>xx1200001067</p>
6	Use caution and pull out the motor cables.	

Removing the axis-2 motor





	Action	Note
1	Before removing the motor, make sure that the axis-2 gearbox is completely drained.	
2	To release the brake, connect the 24 VDC power supply. Connect to connector R2.MP2, axis-2 motor: <ul style="list-style-type: none"> • + = pin 2 • - = pin 5 	

Continues on next page

4 Repair

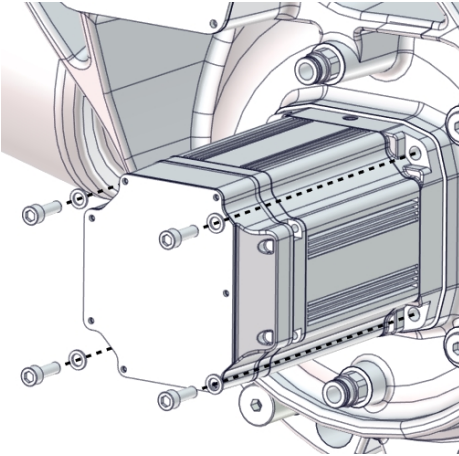
4.7.2 Replacing the axis-2 motor

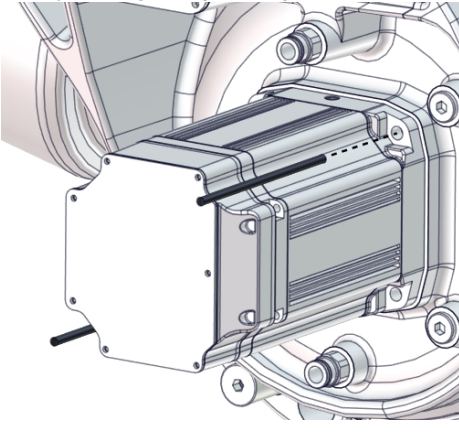
Continued

	Action	Note
3	<p>Remove the attachment screws. Use a bits extender in order to reach the screws.</p>	<p>Bits extender: 3HAC12342-1</p>  <p>xx1700000515</p>
4	<p>Fit guide pins in opposite holes.</p> <p> Tip</p> <p>Lubricate the guide pins with some grease to make the motor slide better.</p>	<p>Guide pin, M10x150: 3HAC15521-2 Always use guide pins in pairs.</p>  <p>xx1700000516</p>
5	<p> CAUTION</p> <p>Whenever parting/mating motor and gearbox, the gears may be damaged if excessive force is used.</p>	
6	<p>If required, press the motor out of its position by using the removal tool in opposite holes of the motor.</p>	<p>Removal tool motor M12: 3HAC14631-1 Always use removal tools in pairs.</p>
7	<p>Disconnect the 24 VDC power supply.</p>	
8	<p> CAUTION</p> <p>The motor weighs 28 kg. All lifting accessories used must be sized accordingly.</p>	
9	<p>Carefully lift the motor out on the guide pins, in order to get the pinion away from the gear and let it rest on the guide pins.</p>	



Continues on next page

	Action	Note
10	Fasten the lifting accessory. Attach the lifting chain to the accessory and an overhead crane.	Lifting accessory, motor: 3HAC15534-1 Lifting accessory (chain): 3HAC15556-1
11	Remove the motor by sliding it out on the guide pins and lift it off.	Make sure the pinion is not damaged.

Refitting the motor

These procedures describes how to refit the motor.

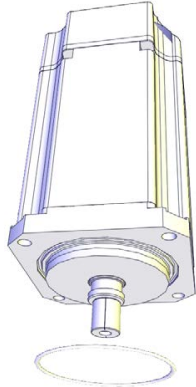
Preparations prior to refitting motor

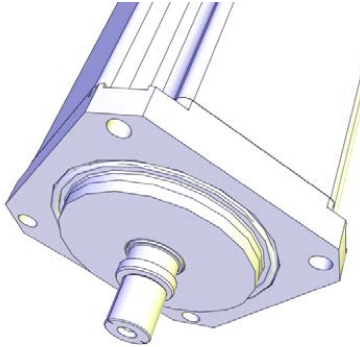

	Action	Note
1	 DANGER Make sure that all supplies for electrical power, hydraulic pressure, and air pressure are turned off.	
2	Remove any old paint residues or other contamination from the contact surfaces on both the motor and the mating parts. Wipe clean the contact surfaces and the o-ring groove.	
3	Fit a new o-ring.	 xx1200001019
4	 Tip Lubricate the o-ring with some grease for a better fitting in the groove.	 xx1200001020

Continues on next page

4 Repair

4.7.2 Replacing the axis-2 motor

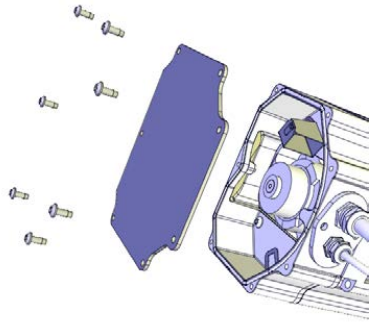

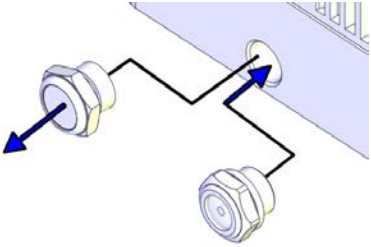
Continued

	Action	Note
5	If the motor is a new spare part, remove the cover.	 <p>xx1200001135</p>
6	<p>Protection type Foundry Plus Valid for axis-2, axis-3, axis-4 and axis-6 motors.</p> <p>If the motor is a new spare part, the evacuation hole protection filter must be replaced with a transparent plug/sight glass (enclosed with the spare part delivery). Remove the protection filter and install the transparent plug/sight glass.</p> <p>On the axis-6 motor there are two protection filters that must be replaced with transparent plugs/sight glasses.</p> <div style="display: flex; justify-content: space-around;"> <div data-bbox="485 1041 758 1261">  <p>xx2200002188</p> <p>Transparent plug (Foundry Plus).</p> </div> <div data-bbox="762 1041 1013 1261">  <p>xx1800000101</p> <p>Protection filter (Standard).</p> </div> </div>	<p>Tightening torque, transparent plug: 20 Nm \pm10%</p> <p>Tightening torque, protection filter: 10 Nm \pm10%</p>  <p>xx1600000576</p>

Securing the axis-2 motor

	Action	Note
1	Fit guide pins in opposite holes.	Guide pin, M10x150: 3HAC15521-2 Always use guide pins in pairs.
2	 CAUTION The motor weighs 28 kg. All lifting accessories used must be sized accordingly.	
3	Apply the lifting accessory.	Lifting accessory, motor: 3HAC15534-1 Lifting accessory (chain): 3HAC15556-1

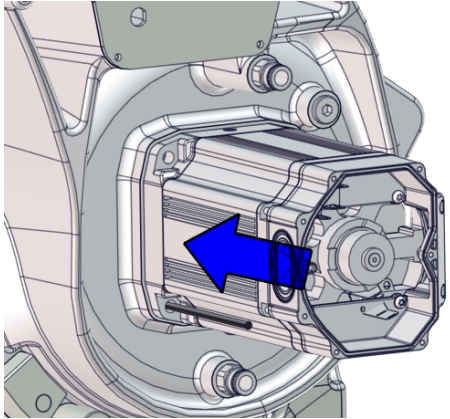
Continues on next page

	Action	Note
4	 Note Make sure the cable gland opening is turned the correct way.	 xx170000517
5	Lift the motor and put it on the guide pins as close as possible to its final position without pushing the motor pinion into the gear.	
6	Remove the lifting accessory and allow the motor to rest on the guide pins.	
7	Apply the rotation tool and use it to rotate the pinion when mating it into the gear.	Rotation tool: 3HAB7887-1
8	To release the brakes, connect the 24 VDC power supply. Connect to connector R2.MP2, axis-2 motor: <ul style="list-style-type: none"> • + = pin 2 • - = pin 5 	
9	 CAUTION Whenever parting/mating motor and gearbox, the gears may be damaged if excessive force is used.	
10	Use caution and fit the motor in its final position while at the same time rotating the motor pinion slightly using the rotation tool. <ul style="list-style-type: none"> • Make sure that the motor pinion is properly mated to the gear of the gearbox. • Make sure that the motor pinion does not get damaged. • Make sure that the direction of the cable exit is facing the correct way. 	
11	Fit two of the attachment screws and washers.	Screws: M10x40 quality 12.9 Gleitmo
12	Remove the guide pins and replace with the remaining attachment screws.	

Continues on next page

4 Repair

4.7.2 Replacing the axis-2 motor

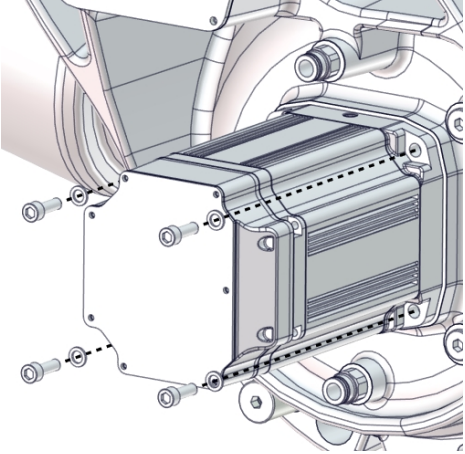

Continued

	Action	Note
13	Secure the motor with its attachment screws and washers. Use a bits extender in order to reach the screws.	Bits extender: 3HAC12342-1 Tightening torque: 50 Nm. Screw dimension: M10x40 quality 12.9 Gleitmo (4 pcs)  xx1700000515
14	Perform a leak-down test.	See Performing a leak-down test on page 188 .

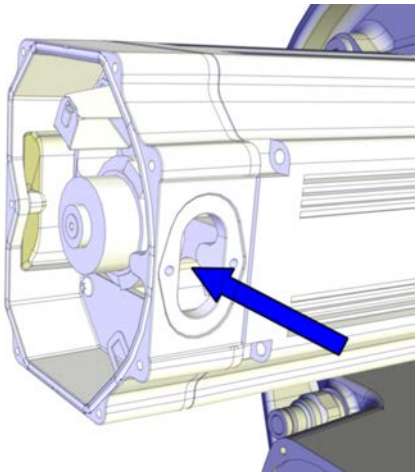
Connecting the motor cables

	Action	Note
1	Push the motor cables through the cable gland opening.	 xx1300000738

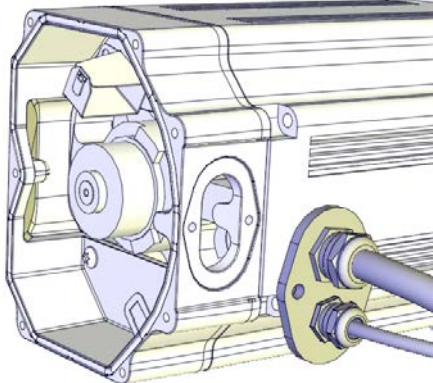
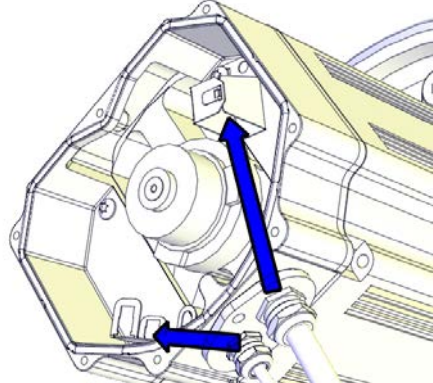
Continues on next page

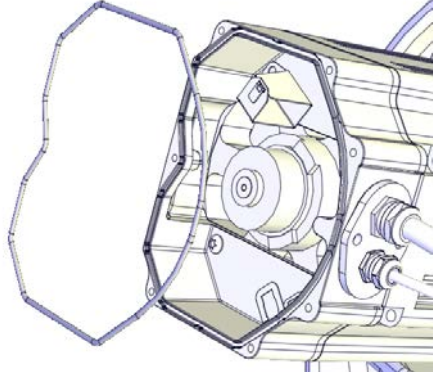



	Action	Note
2	<p>Refit the cable gland cover.</p> <p> Note Replace the gasket if damaged.</p>	 <p>xx1200001067</p>
3	<p>Connect the motor cables. Connect in accordance with the markings on the connectors.</p>	 <p>xx1200001066</p>
4	<p>Inspect the o-ring.</p> <p> Note Replace if damaged.</p>	<p>O-ring, axis-1: 3HAC054692-002 O-ring, axis-2: 3HAC054692-002 O-ring, axis-3: 3HAC054692-002 O-ring, axis-4: 3HAC054692-001</p>  <p>xx1200001070</p>
5	<p>Wipe clean o-ring and o-ring groove.</p>	

Continues on next page

4 Repair

4.7.2 Replacing the axis-2 motor

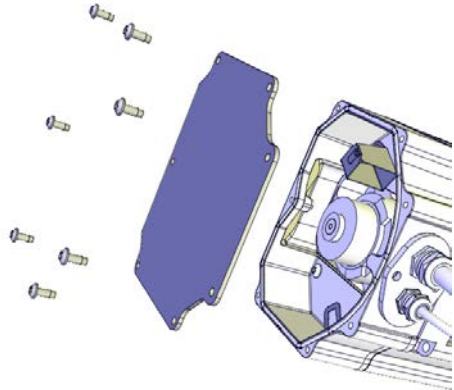

Continued

	Action	Note
6	<p>Refit the o-ring.</p> <p> Tip</p> <p>Lubricate the o-ring with some grease for a better fitting in the groove.</p>	
7	<p> CAUTION</p> <p>When fitting the motor cover, make sure that none of the cables inside will be damaged.</p>	
8	<p>Refit the motor cover with it's attachment screws.</p> <p> Note</p> <p>Do not reuse the self-threading attachment screws. Replace with standard attachment screws or the threads will be damaged.</p> <p> Note</p> <p>Make sure the o-ring is undamaged and properly fitted.</p>	<p>Attachment screws: M5x12 8.8 (7 pcs)</p>  <p>xx1200001135</p>
9	<p>Make sure that the covers are tightly sealed.</p>	

Concluding procedure

	Action	Note
1	<p>Use caution and jog axis-2 a little to facilitate the removal of the lock screw.</p>	

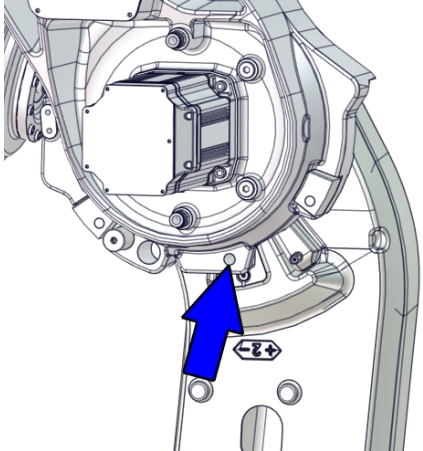
Continues on next page

	Action	Note
2	Remove the lock screw securing the lower arm.	Lock screw, M16x120  xx1700000513
3	<i>Foundry Plus:</i> Apply Mercasol in the hole for the lock screw.	
4	Refill the gearbox with oil.	See Filling oil into the axis-2 gearbox on page 160 .
5	Re-calibrate the robot.	Axis Calibration is described in Calibrating with Axis Calibration method on page 694 . General calibration information is included in section Calibration on page 683 .
6	 DANGER Make sure all safety requirements are met when performing the first test run. See Test run after installation, maintenance, or repair on page 97 .	

4 Repair

4.7.3 Replacing the axis-3 motor

4.7.3 Replacing the axis-3 motor

Location of the axis-3 motor

The axis-3 motor is located as shown in the figure.

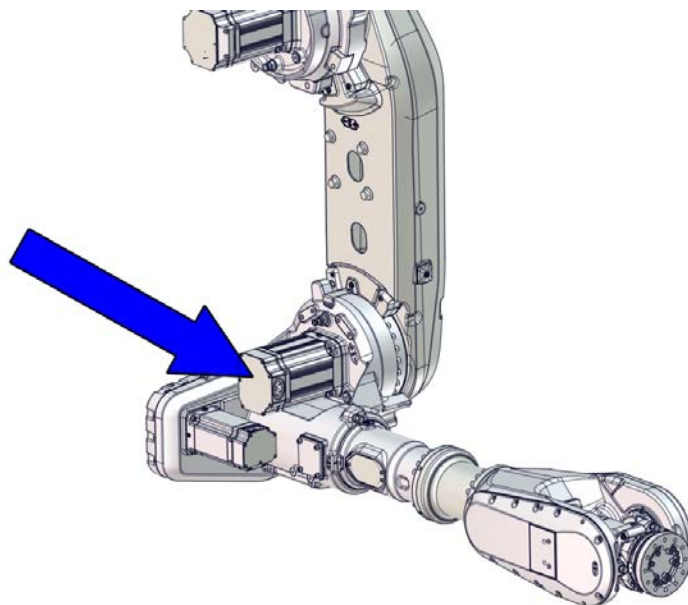

xx170000123

Spare part

Spare part	Spare part number	Note
Axis-3 motor	See <i>Product manual, spare parts - IRB 6700/IRB 6700Inv</i>	

Consumables

Equipment, etc.	Article number	Note
Grease	3HAC042536-001	Shell Gadus S2 Used to lubricate o-rings.
O-ring	3HAC054692-002	D=169.5x3 Used on motor cover.
O-ring	3HAB3772-107	D=102x3 Used on motor flange.

Required tools and equipment

Equipment, etc.	Article number	Note
Chain block	-	Used together with a lifting sling and a lifting eye for securing the weight. The chain block included in the turning tool for the robot can be used (Turning tool: 3HAC073537-001).
Lifting eye, M12	3HAC16131-1	

Continues on next page

Equipment, etc.	Article number	Note
Roundsling, 1 m	-	Lifting capacity: 1,000 kg.
Lifting accessory (chain)	3HAC15556-1	Lifting instruction 3HAC15880-2 enclosed.
Lifting accessory, motor	3HAC15534-1	Lifting instruction 3HAC15640-2 enclosed.
Removal tool motor M12	3HAC14631-1	Used to push out the motor, if necessary. Always use removal tools in pairs.
Guide pin, M10x150	3HAC15521-2	Always use guide pins in pairs.
Bits extender	3HAC12342-1	300 mm, bits 1/2"
Rotation tool	3HAB7887-1	Used to rotate the motor pinion.
24 VDC power supply	-	Used to release the motor brakes.
Leak-down tester	-	
Calibration tool box, Axis Calibration	3HAC055412-001	Delivered as a set of calibration tools.
Standard toolkit	-	Content is defined in section Standard toolkit on page 724 .

Deciding calibration routine

Decide which calibration routine to be used, based on the information in the table. Depending on which routine is chosen, action might be required prior to beginning the repair work of the robot, see the table.

	Action	Note
1	Decide which calibration routine to use for calibrating the robot. <ul style="list-style-type: none"> Reference calibration. External cable packages (DressPack) and tools can stay fitted on the robot. Fine calibration. All external cable packages (DressPack) and tools must be removed from the robot. 	
	If the robot is to be calibrated with reference calibration: Find previous reference values for the axis or create new reference values. These values are to be used after the repair procedure is completed, for calibration of the robot. If no previous reference values exist, and no new reference values can be created, then reference calibration is not possible.	Follow the instructions given in the reference calibration routine on the FlexPendant to create reference values. Creating new values requires possibility to move the robot. Read more about reference calibration for Axis Calibration in Reference calibration routine on page 695 .
	If the robot is to be calibrated with fine calibration: Remove all external cable packages (DressPack) and tools from the robot.	

Continues on next page

4 Repair

4.7.3 Replacing the axis-3 motor

Continued

Removing the motor

These procedures describes how to remove the motor.

Preparations before removing the axis-3 motor

Use this procedure to do the necessary preparations before removing the motor.

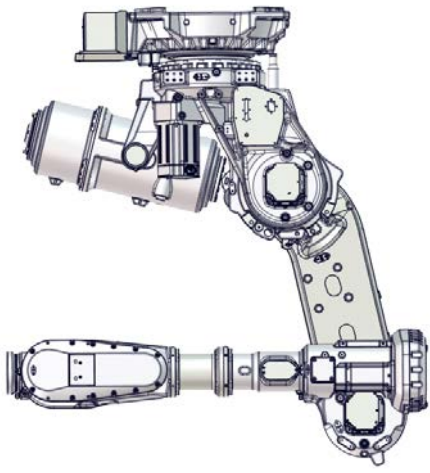
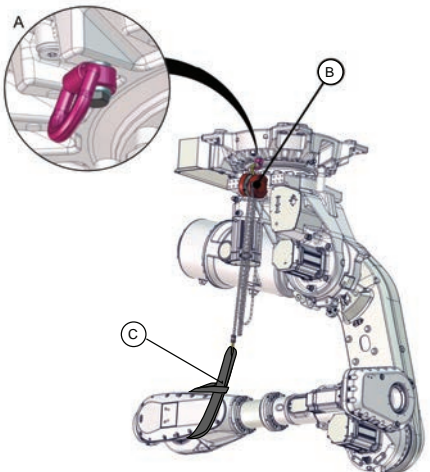
	Action	Note
1	Decide which calibration routine to use, and take actions accordingly prior to beginning the repair procedure.	
2	Drain the axis-3 gearbox.	See Draining the axis-3 gearbox on page 163 .
3	<p>Jog axis 2 +20° and axis 3 -200°. The upper arm should be horizontal.</p> <p>Unload the weight of the upper arm using one of these methods:</p> <ul style="list-style-type: none"> • Use a fork lift to rest the upper arm onto. • Use lifting slings and an overhead crane to rest the upper arm onto. • Secure the upper arm with a lifting eye, a lifting sling and a chain block. <p>Fit the lifting eye at the base of the robot, the lifting sling around the wrist and the chain block in between. Strain the lifting sling with the chain block until the weight of the upper arm is unloaded.</p>	 <p>xx170000258</p> <p>The figure shows the third method of securing the upper arm weight.</p>  <p>xx170000360</p> <p>A Lifting eye, M12 B Chain block C Roundslings, 1 m</p>

Continues on next page

	Action	Note
4	 DANGER Turn off all: <ul style="list-style-type: none"> • electric power supply • hydraulic pressure supply • air pressure supply to the robot, before entering the safe-guarded space.	
5	Remove any equipment hindering access to the motor.	

Disconnecting the motor cables

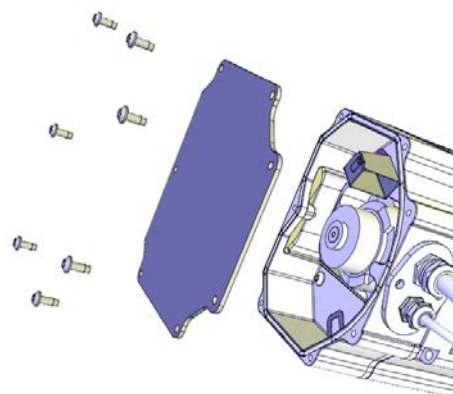
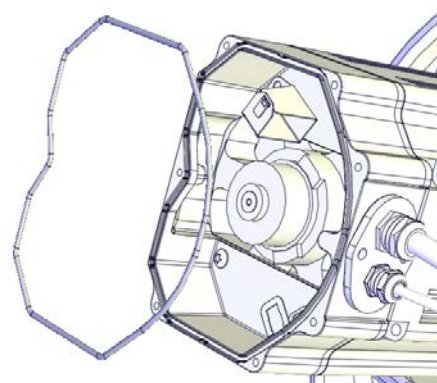

	Action	Note
1	 DANGER Make sure that all supplies for electrical power, hydraulic pressure, and air pressure are turned off.	
2	Unscrew the attachment screws and washers and remove the motor cover.	 <p>xx1200001135</p>
3	Make sure the o-ring is present.	 <p>xx1200001070</p>

Continues on next page

4 Repair

4.7.3 Replacing the axis-3 motor

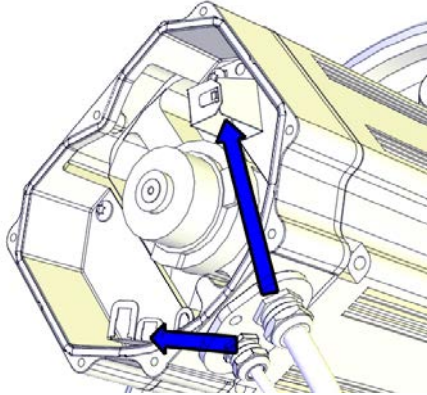

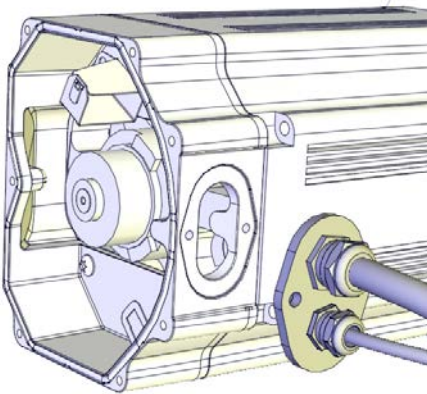

Continued

	Action	Note
4	Disconnect the motor cables.	 <p>xx1200001066</p>
5	Remove the cable gland cover. Make sure the gasket is not damaged.  Tip Make a note in which direction the cable gland hole is facing, if the motor will be removed too. The motor shall be refitted in the same position.	 <p>xx1200001067</p>
6	Use caution and pull out the motor cables.	

Removing the axis-3 motor

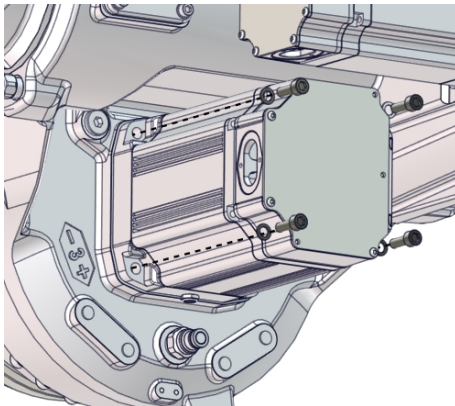
	Action	Note
1	Before removing the motor, make sure that the axis-3 gearbox is completely drained.	
2	 DANGER When releasing the holding brakes of the motor, the upper arm will be movable and may fall down if not secured. Verify that the upper arm is secured as previously described, before continuing.	
3	To release the brakes, connect the 24 VDC power supply. Connect to connector R2.MP3: <ul style="list-style-type: none"> • + = pin 2 • - = pin 5 	

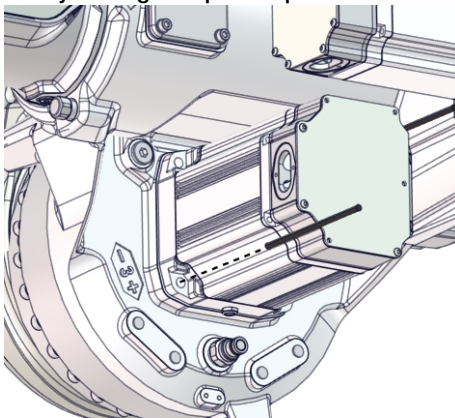
Continues on next page

	Action	Note
4	<p>Unscrew the attachment screws that hold the motor. Use a bits extender to reach the screws.</p>	<p>Bits extender: 3HAC12342-1</p>  <p>xx1700000285</p>
5	<p>Fit guide pins in opposite holes.</p> <p> Tip</p> <p>Lubricate the guide pins with some grease to make the motor slide better.</p>	<p>Guide pin, M10x150: 3HAC15521-2 Always use guide pins in pairs.</p>  <p>xx1700000346</p>
6	<p> CAUTION</p> <p>Whenever parting/mating motor and gear-box, the gears may be damaged if excessive force is used.</p>	
7	<p>If required, press the motor out of position by using the removal tool in the remaining holes for the motor.</p>	<p>Removal tool motor M12: 3HAC14631-1 Always use removal tools in pairs.</p>
8	<p>Use caution and lift the motor out on the guide pins, in order to get the pinion away from the gear, and let the motor rest on the guide pins.</p>	
9	<p> CAUTION</p> <p>The motor weighs 26 kg. All lifting accessories used must be sized accordingly.</p>	

Continues on next page

4 Repair

4.7.3 Replacing the axis-3 motor

Continued

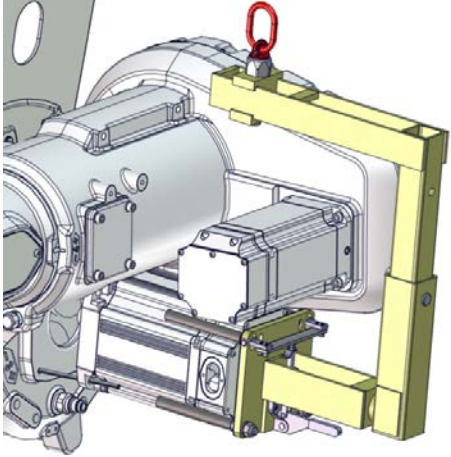
	Action	Note
10	Fasten the lifting accessory to the motor. Attach the lifting chain to the accessory and an overhead crane.	Lifting accessory, motor: 3HAC15534-1 Lifting accessory (chain): 3HAC15556-1
11	When the motor is hanging in the lifting accessory, and the pinion no longer is mated to the gear, let the outer end of the motor hang lower so that it will hang in an angle. This position makes it easier to remove the axis-3 motor with the axis-4 motor still fitted.  CAUTION The pinion must have been parted from the gear before the motor is angled. If not there is a risk of damaging the pinion and gear.	 xx170000271
12	Disconnect the 24 VDC power supply.	
13	Remove the motor by lifting it straight out.	Make sure the pinion is not damaged.

Refitting the motor

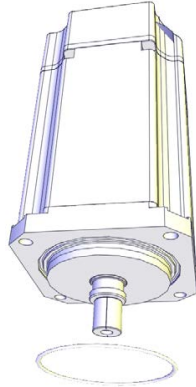

These procedures describes how to refit the motor.

Preparations prior to refitting motor

	Action	Note
1	 DANGER Make sure that all supplies for electrical power, hydraulic pressure, and air pressure are turned off.	
2	Remove any old paint residues or other contamination from the contact surfaces on both the motor and the mating parts. Wipe clean the contact surfaces and the o-ring groove.	
3	Fit a new o-ring.	 xx1200001019

Continues on next page

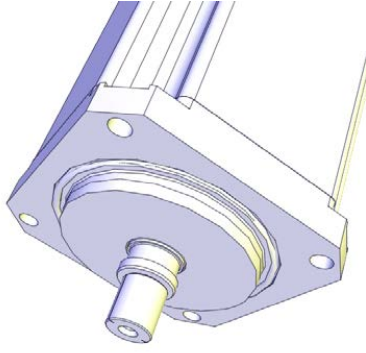
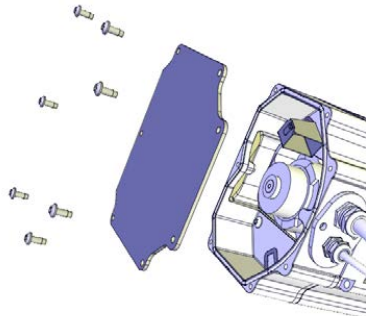
4.7.3 Replacing the axis-3 motor
Continued

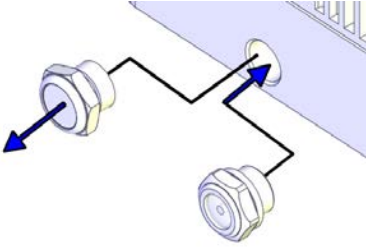
	Action	Note
4	<p>Make sure the o-ring is seated in the groove.</p> <p> Tip</p> <p>Lubricate the o-ring with some grease for a better fitting in the groove.</p>	 <p>xx1200001020</p>
5	<p>If the motor is a new spare part, remove the cover.</p>	 <p>xx1200001135</p>
6	<p><i>Protection type Foundry Plus</i></p> <p>Valid for axis-2, axis-3, axis-4 and axis-6 motors.</p> <p>If the motor is a new spare part, the evacuation hole protection filter must be replaced with a transparent plug/sight glass (enclosed with the spare part delivery). Remove the protection filter and install the transparent plug/sight glass.</p> <p>On the axis-6 motor there are two protection filters that must be replaced with transparent plugs/sight glasses.</p> <div style="display: flex; justify-content: space-around;"> <div data-bbox="518 1467 790 1691">  <p>xx2200002188</p> <p>Transparent plug (Foundry Plus).</p> </div> <div data-bbox="790 1467 1045 1691">  <p>xx1800000101</p> <p>Protection filter (Standard).</p> </div> </div>	<p>Tightening torque, transparent plug: 20 Nm \pm10%</p> <p>Tightening torque, protection filter: 10 Nm \pm10%</p>  <p>xx1600000576</p>

Continues on next page



4 Repair

4.7.3 Replacing the axis-3 motor

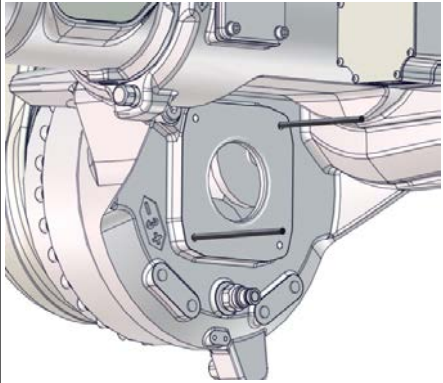

Continued

Securing the axis-3 motor

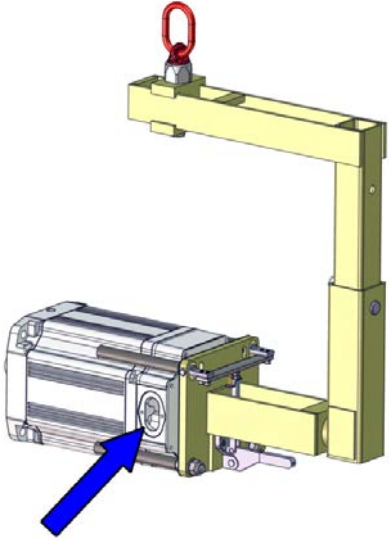
Use this procedure to secure the motor.

	Action	Note
1	Fit guide pins in opposite holes.	<p>Guide pin, M10x150: 3HAC15521-2 Always use guide pins in pairs.</p>  <p>xx1700000272</p>
2	 CAUTION The motor weighs 26 kg. All lifting accessories used must be sized accordingly.	
3	Apply the lifting accessories to the motor.  Note Make sure the cable gland exit is turned according to figure.	<p>Lifting accessory, motor: 3HAC15534-1</p>  <p>xx1700000273</p>

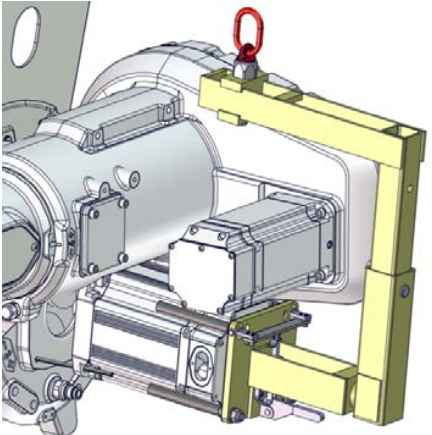
Continues on next page

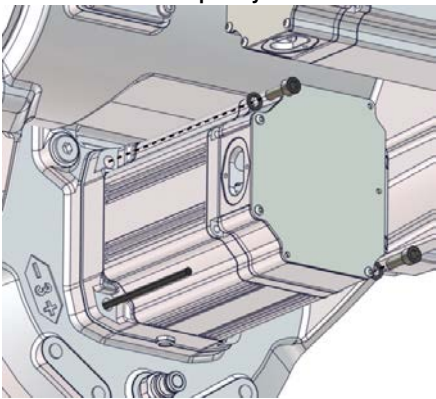
	Action	Note
4	<p>Lift the motor on to the guide pins and let it hang with the outer end a little lower when resting on the guide pins. Do not push the motor pinion into the gear yet.</p> <p>This is done in order to fit the motor with the axis-4 motor still fitted.</p>	 <p>xx1700000271</p>
5	<p>Remove the lifting accessory and allow the motor to rest on the guide pins.</p>	
6	<p>Apply the rotation tool and use it to rotate the pinion when mating it into the gear.</p>	<p>Rotation tool: 3HAB7887-1</p>
7	<p>To release the brakes, connect the 24 VDC power supply.</p> <p>Connect to connector R2.MP3:</p> <ul style="list-style-type: none"> • + = pin 2 • - = pin 5 	
8	<p> CAUTION</p> <p>Whenever parting/mating motor and gearbox, the gears may be damaged if excessive force is used.</p>	
9	<p>Use caution and push the motor in position while at the same time the motor pinion is slightly rotated.</p> <p>Pay attention to following points:</p> <ul style="list-style-type: none"> • Mate the motor pinion properly to the gear of the gearbox. • Do not damage the motor pinion. 	
10	<p>Fit two of the attachment screws and washers.</p>	<p>Screws: M10x30 quality 12.9 Gleitmo</p>  <p>xx1700000259</p>

Continues on next page



4 Repair

4.7.3 Replacing the axis-3 motor



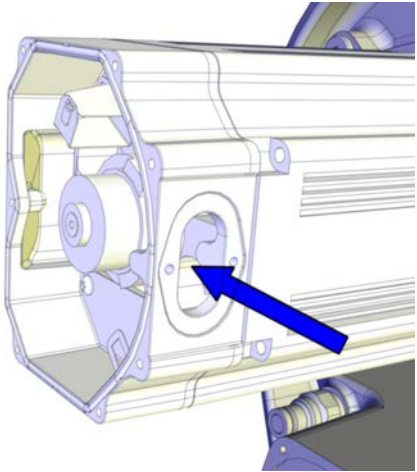

Continued

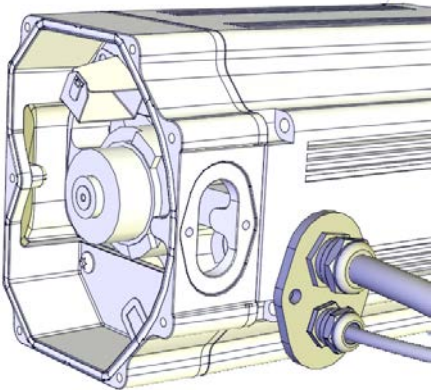
	Action	Note
11	Remove the guide pins.	
12	Fit the remaining attachment screws and washers.	Screws: M10x30 quality 12.9 Gleitmo
13	Tighten the screws.	Tightening torque: 50 Nm
14	Remove the rotation tool.	
15	Perform a leak-down test.	See Performing a leak-down test on page 188 .
16	Disconnect the 24 VDC power supply.	

Connecting the motor cables

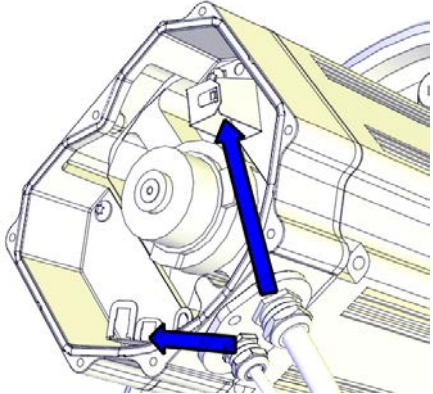
	Action	Note
1	Push the motor cables through the cable gland opening.	 <p>xx130000738</p>
2	Refit the cable gland cover.  Note Replace the gasket if damaged.	 <p>xx1200001067</p>

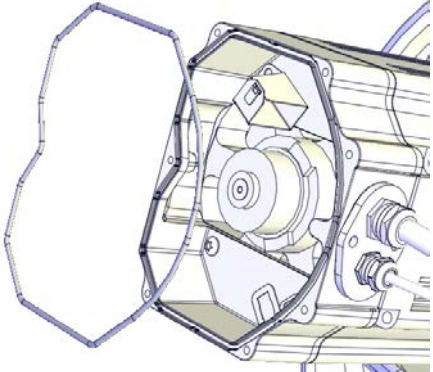
Continues on next page



	Action	Note
3	<p>Connect the motor cables. Connect in accordance with the markings on the connectors.</p>	 <p>xx1200001066</p>
4	<p>Inspect the o-ring.</p> <p> Note Replace if damaged.</p>	<p>O-ring, axis-1: 3HAC054692-002 O-ring, axis-2: 3HAC054692-002 O-ring, axis-3: 3HAC054692-002 O-ring, axis-4: 3HAC054692-001</p>  <p>xx1200001070</p>
5	<p>Wipe clean o-ring and o-ring groove.</p>	
6	<p>Refit the o-ring.</p> <p> Tip Lubricate the o-ring with some grease for a better fitting in the groove.</p>	
7	<p> CAUTION When fitting the motor cover, make sure that none of the cables inside will be damaged.</p>	

Continues on next page

4 Repair

4.7.3 Replacing the axis-3 motor

Continued

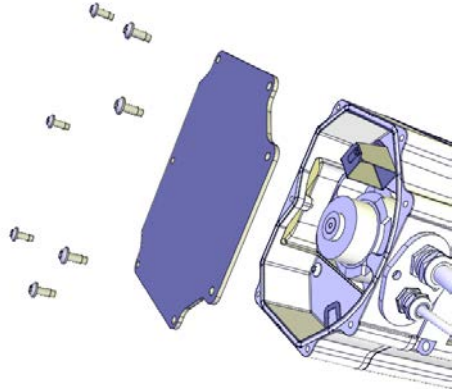
	Action	Note
8	<p>Refit the motor cover with its attachment screws.</p> <p> Note</p> <p>Do not reuse the self-threading attachment screws. Replace with standard attachment screws or the threads will be damaged.</p> <p> Note</p> <p>Make sure the o-ring is undamaged and properly fitted.</p>	<p>Attachment screws: M5x12 8.8 (7 pcs)</p>  <p>xx1200001135</p>
9	<p>Make sure that the covers are tightly sealed.</p>	

Concluding procedure

Use this procedure for the concluding refitting.

	Action	Note
1	<p>Remove the equipment used to unload the upper arm.</p>	
2	<p>Refill the gearbox with oil.</p>	<p>See Filling oil into the axis-3 gearbox on page 164.</p>
3	<p>Re-calibrate the robot.</p>	<p>Axis Calibration is described in Calibrating with Axis Calibration method on page 694. General calibration information is included in section Calibration on page 683.</p>
4	<p> DANGER</p> <p>Make sure all safety requirements are met when performing the first test run. See Test run after installation, maintenance, or repair on page 97.</p>	

4.7.4 Replacing the axis-4 motor

Location of the axis-4 motor

The axis-4 motor is located as shown in the figure.

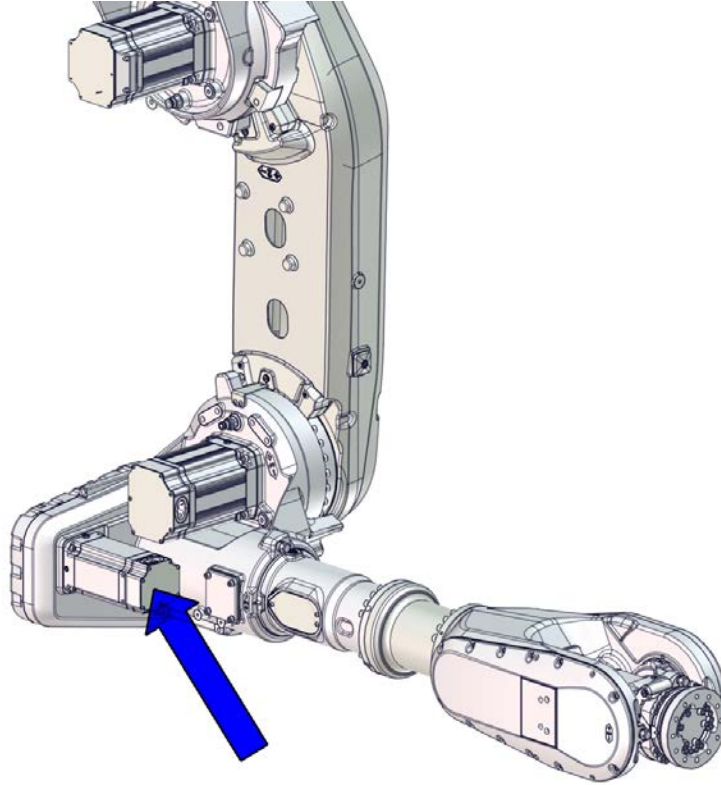

xx170000289

Spare parts

Spare part	Spare part number	Note
Axis-4 motor	See <i>Product manual, spare parts - IRB 6700/IRB 6700Inv</i>	

Consumables

Equipment, etc.	Article number	Note
Grease	3HAC042536-001	Shell Gadus S2 Used to lubricate o-rings.
O-ring	3HAC054692-001	D=119x3 Used on motor cover.
O-ring	3HAB3772-107	D=102x3 Used on motor flange.

Continues on next page

4 Repair

4.7.4 Replacing the axis-4 motor

Continued

Required tools and equipment

Equipment, etc.	Article number	Note
Removal tool motor M12	3HAC14631-1	Used to push out the motor, if necessary. Always use removal tools in pairs.
Guide pin, M8x150	3HAC15520-2	Always use guide pins in pairs.
Long Allen key socket IN19L 6-140	-	Length: 140 mm.
Rotation tool	3HAB7887-1	Used to rotate the motor pinion.
24 VDC power supply	-	Used to release the motor brakes.
Leak-down tester	-	
Calibration tool box, Axis Calibration	3HAC055412-001	Delivered as a set of calibration tools.
Standard toolkit	-	Content is defined in section Standard toolkit on page 724 .

Deciding calibration routine

Decide which calibration routine to be used, based on the information in the table. Depending on which routine is chosen, action might be required prior to beginning the repair work of the robot, see the table.

	Action	Note
1	Decide which calibration routine to use for calibrating the robot. <ul style="list-style-type: none">Reference calibration. External cable packages (DressPack) and tools can stay fitted on the robot.Fine calibration. All external cable packages (DressPack) and tools must be removed from the robot.	
	If the robot is to be calibrated with reference calibration: Find previous reference values for the axis or create new reference values. These values are to be used after the repair procedure is completed, for calibration of the robot. If no previous reference values exist, and no new reference values can be created, then reference calibration is not possible.	Follow the instructions given in the reference calibration routine on the FlexPendant to create reference values. Creating new values requires possibility to move the robot. Read more about reference calibration for Axis Calibration in Reference calibration routine on page 695 .
	If the robot is to be calibrated with fine calibration: Remove all external cable packages (DressPack) and tools from the robot.	

Continues on next page

Removing the motor

These procedures describes how to remove the motor.

Preparations before removing the axis-4 motor

	Action	Note
1	Decide which calibration routine to use, and take actions accordingly prior to beginning the repair procedure.	
2	Jog the robot into position: <ul style="list-style-type: none"> • axis 1 = no significance. • axis 2 = +20° • axis 3 = +70° (upper arm pointing straight up, if possible). With the robot in this position, there is no need to drain oil from the axis-4 gearbox when the motor is replaced.	
3	If there is no space to position the upper arm pointed straight up, drain the axis-4 gearbox.	
4	 DANGER Turn off all: <ul style="list-style-type: none"> • electric power supply • hydraulic pressure supply • air pressure supply to the robot, before entering the safe-guarded space.	

Disconnecting the motor cables

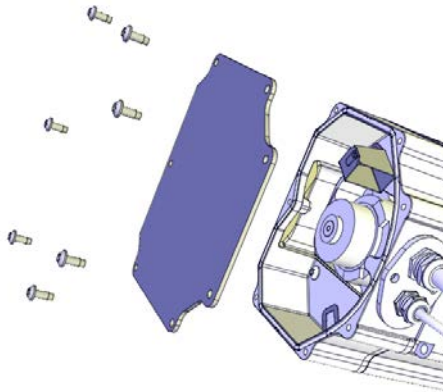

	Action	Note
1	 DANGER Make sure that all supplies for electrical power, hydraulic pressure, and air pressure are turned off.	
2	Unscrew the attachment screws and washers and remove the motor cover.	 <p>xx1200001135</p>

Continues on next page

4 Repair

4.7.4 Replacing the axis-4 motor

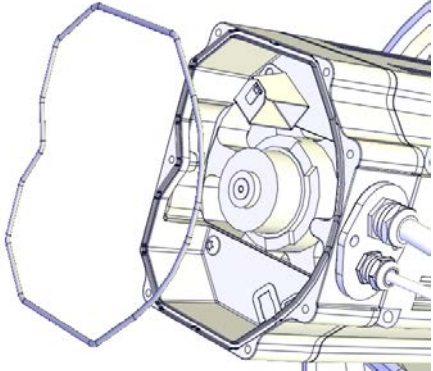
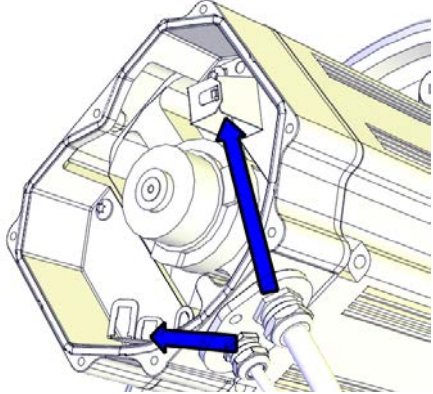

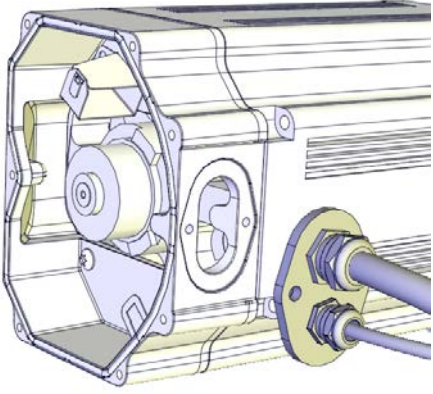
Continued

	Action	Note
3	Make sure the o-ring is present.	 <p>xx1200001070</p>
4	Disconnect the motor cables.	 <p>xx1200001066</p>
5	Remove the cable gland cover. Make sure the gasket is not damaged.  Tip Make a note in which direction the cable gland hole is facing, if the motor will be removed too. The motor shall be refitted in the same position.	 <p>xx1200001067</p>
6	Use caution and pull out the motor cables.	

Removing the axis-4 motor

	Action	Note
1	 CAUTION Use caution when releasing the brakes! Axis-4 can move unexpectedly!	

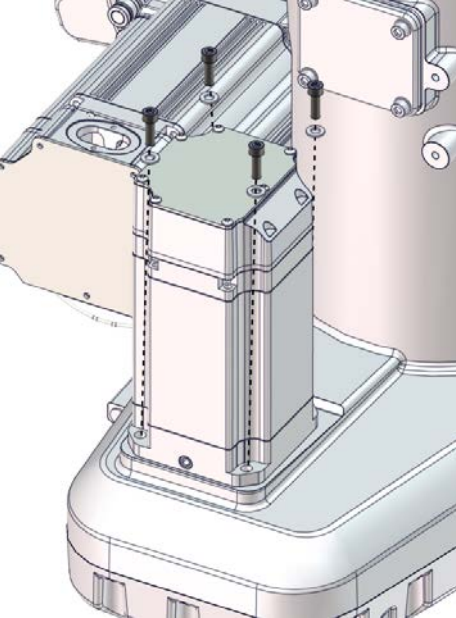
Continues on next page

	Action	Note
2	To release the brakes, connect the 24 VDC power supply. Connect to connector R2.MP4: <ul style="list-style-type: none"> • + = pin 2 • - = pin 5 	
3	Unscrew the attachment screws that secure the motor.	 <p>xx170000290</p>
4	Apply two guide pins in opposite holes.	Guide pin, M8x150: 3HAC15520-2 Always use guide pins in pairs.
5	 CAUTION Whenever parting/mating motor and gearbox, the gears may be damaged if excessive force is used.	
6	Press the motor out of position by fitting the removal tool in the remaining attachment holes for the motor.	Removal tool motor M12: 3HAC14631-1 Always use removal tools in pairs.
7	 CAUTION The motor weighs 13 kg. All lifting accessories used must be sized accordingly.	
8	Disconnect the 24 VDC power supply.	

Continues on next page

4 Repair

4.7.4 Replacing the axis-4 motor

Continued

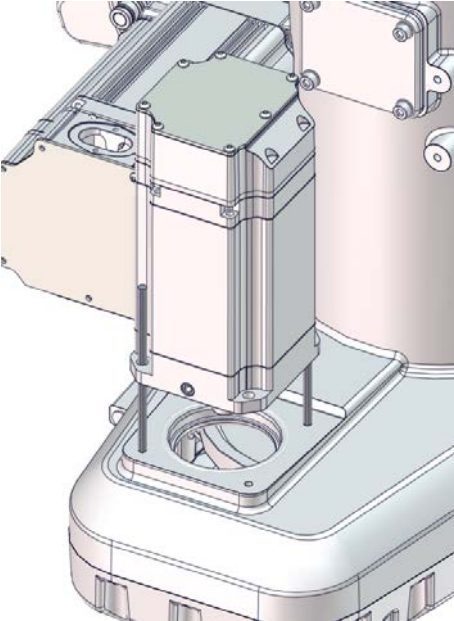
	Action	Note
9	<p>Remove the motor by carefully lifting it straight out/straight up (if the upper arm points upwards). Make sure the pinion is not damaged.</p>	 <p>xx170000291</p>



Refitting the motor

These procedures describes how to refit the motor.

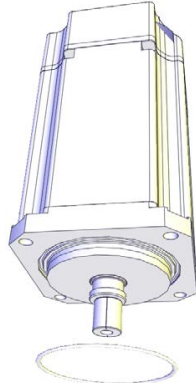
Preparations prior to refitting motor

	Action	Note
1	 <p>DANGER</p> <p>Make sure that all supplies for electrical power, hydraulic pressure, and air pressure are turned off.</p>	
2	<p>Remove any old paint residues or other contamination from the contact surfaces on both the motor and the mating parts. Wipe clean the contact surfaces and the o-ring groove.</p>	
3	<p>Fit a new o-ring.</p>	 <p>xx1200001019</p>

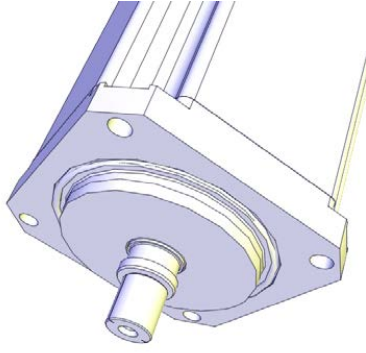
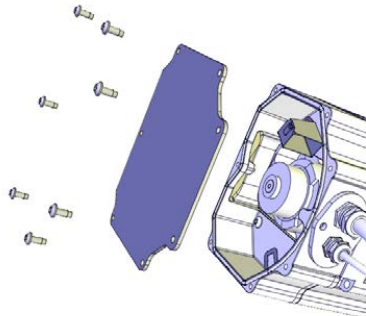
Continues on next page

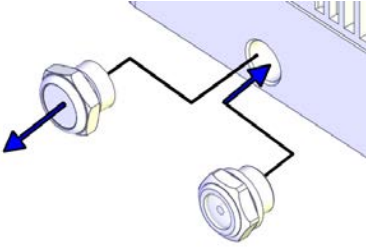
	Action	Note
4	<p>Make sure the o-ring is seated in the groove.</p> <p> Tip</p> <p>Lubricate the o-ring with some grease for a better fitting in the groove.</p>	 <p>xx1200001020</p>
5	<p>If the motor is a new spare part, remove the cover.</p>	 <p>xx1200001135</p>
6	<p><i>Protection type Foundry Plus</i></p> <p>Valid for axis-2, axis-3, axis-4 and axis-6 motors.</p> <p>If the motor is a new spare part, the evacuation hole protection filter must be replaced with a transparent plug/sight glass (enclosed with the spare part delivery). Remove the protection filter and install the transparent plug/sight glass.</p> <p>On the axis-6 motor there are two protection filters that must be replaced with transparent plugs/sight glasses.</p> <div style="display: flex; justify-content: space-around;"> <div data-bbox="518 1467 790 1691">  <p>xx2200002188</p> <p>Transparent plug (Foundry Plus).</p> </div> <div data-bbox="790 1467 1045 1691">  <p>xx1800000101</p> <p>Protection filter (Standard).</p> </div> </div>	<p>Tightening torque, transparent plug: 20 Nm \pm10%</p> <p>Tightening torque, protection filter: 10 Nm \pm10%</p>  <p>xx1600000576</p>

Securing the axis-4 motor





	Action	Note
1	<p>Apply two guide pins in opposite holes.</p>	<p>Guide pin, M8x150: 3HAC15520-2</p> <p>Always use guide pins in pairs.</p>

Continues on next page

4 Repair

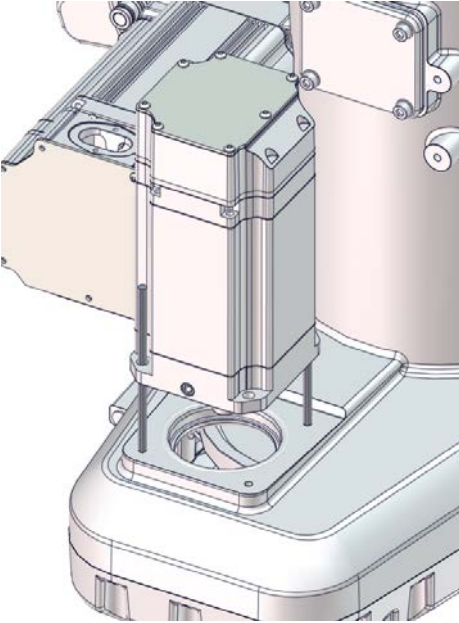
4.7.4 Replacing the axis-4 motor

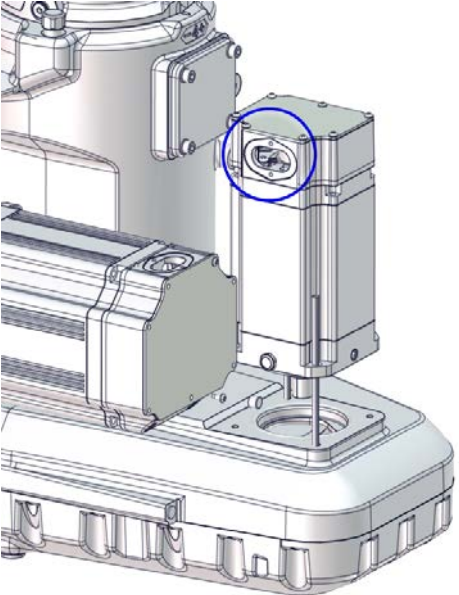
Continued

	Action	Note
2	Put the motor onto the guide pins.	 <p>xx170000291</p>
3	 Note Make sure the cable gland opening is turned the correct way.	 <p>xx170000292</p>
4	 CAUTION The motor weighs 13 kg. All lifting accessories used must be sized accordingly.	
5	Apply the rotation tool and use it to rotate the pinion when mating it into the gear. This requires two persons co-operating, if the motor is installed from above (if the upper arm is pointing upwards).	Rotation tool: 3HAB7887-1

Continues on next page

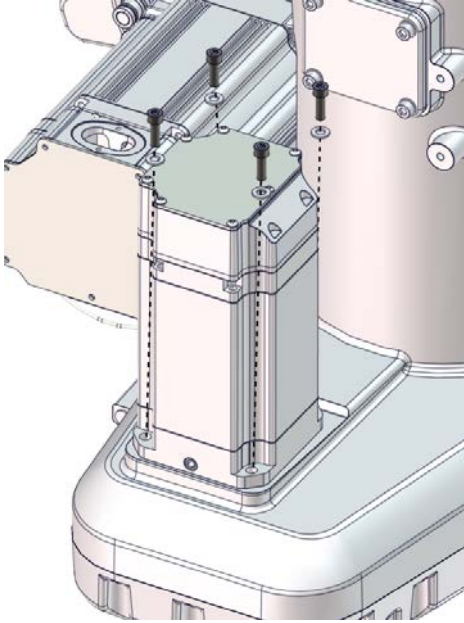
	Action	Note
6	To release the brakes, connect the 24 VDC power supply. Connect to connector R2.MP2: <ul style="list-style-type: none"> • + = pin 2 • - = pin 5 	
7	 CAUTION Whenever parting/mating motor and gearbox, the gears may be damaged if excessive force is used.	
8	Push the motor carefully in position while at the same time rotating the motor pinion slightly. <ul style="list-style-type: none"> • Make sure that the motor pinion is properly mated to the gear of the gearbox. • Make sure that the motor pinion does not get damaged. • Make sure that the direction of the cable gland is facing the correct way. 	
9	Remove the guide pins.	
10	Secure the motor with its attachment screws and washers.	Tightening torque: 35 Nm. Screws: M8x30 quality 12.9 Gleitmo (4 pcs)  xx170000290
11	Perform a leak-down test.	See Performing a leak-down test on page 188 .
12	Disconnect the 24 VDC power supply.	



Continues on next page

4 Repair



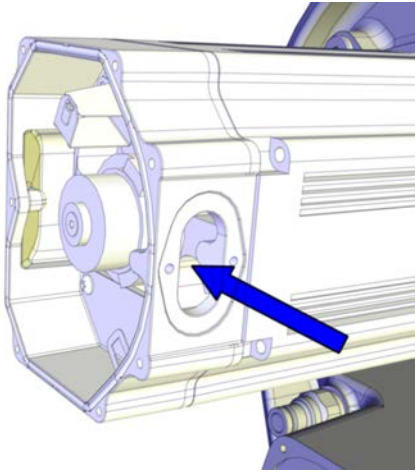

4.7.4 Replacing the axis-4 motor

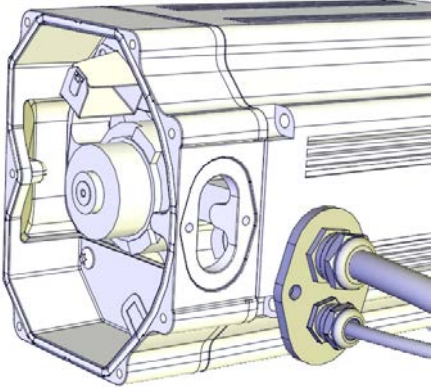
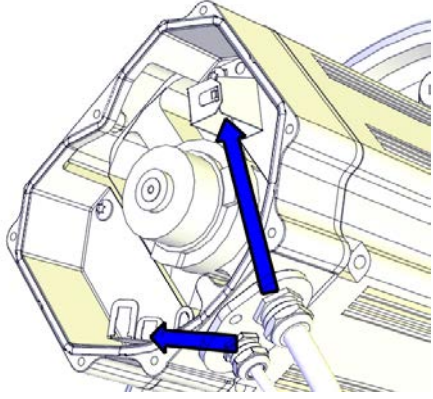
Continued

Connecting the motor cables

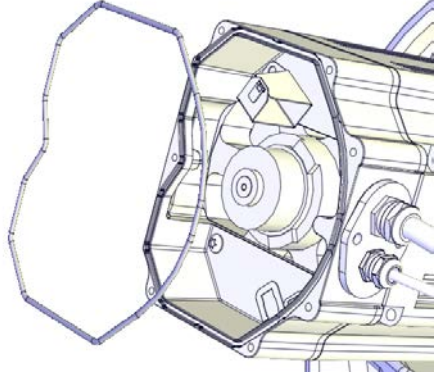
	Action	Note
1	Push the motor cables through the cable gland opening.	 xx130000738
2	Refit the cable gland cover.  Note Replace the gasket if damaged.	 xx1200001067
3	Connect the motor cables. Connect in accordance with the markings on the connectors.	 xx1200001066

Continues on next page

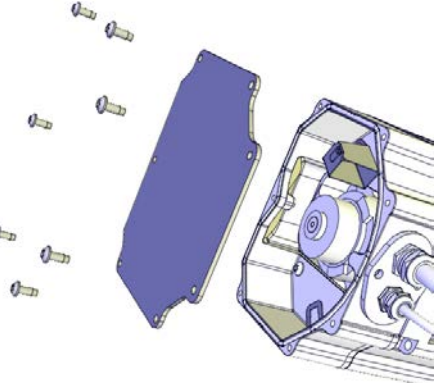
	Action	Note
4	<p>Inspect the o-ring.</p> <p> Note</p> <p>Replace if damaged.</p>	<p>O-ring, axis-1: 3HAC054692-002 O-ring, axis-2: 3HAC054692-002 O-ring, axis-3: 3HAC054692-002 O-ring, axis-4: 3HAC054692-001</p>  <p>xx1200001070</p>
5	<p>Wipe clean o-ring and o-ring groove.</p>	
6	<p>Refit the o-ring.</p> <p> Tip</p> <p>Lubricate the o-ring with some grease for a better fitting in the groove.</p>	
7	<p> CAUTION</p> <p>When fitting the motor cover, make sure that none of the cables inside will be damaged.</p>	
8	<p>Refit the motor cover with it's attachment screws.</p> <p> Note</p> <p>Do not reuse the self-threading attachment screws. Replace with standard attachment screws or the threads will be damaged.</p> <p> Note</p> <p>Make sure the o-ring is undamaged and properly fitted.</p>	<p>Attachment screws: M5x12 8.8 (7 pcs)</p>  <p>xx1200001135</p>
9	<p>Make sure that the covers are tightly sealed.</p>	

Continues on next page

4 Repair

4.7.4 Replacing the axis-4 motor

Continued

Concluding procedure

	Action	Note
1	Refill the gearbox with oil, if gearbox has been drained.	See Filling oil into the axis-4 gearbox on page 169 .
2	Re-calibrate the robot.	Axis Calibration is described in Calibrating with Axis Calibration method on page 694 . General calibration information is included in section Calibration on page 683 .
3	 DANGER Make sure all safety requirements are met when performing the first test run. See Test run after installation, maintenance, or repair on page 97 .	

4.7.5 Replacing the axis-5 motor

Location of the axis-5 motor

The axis-5 motor is located inside the wrist, as shown in the figure.

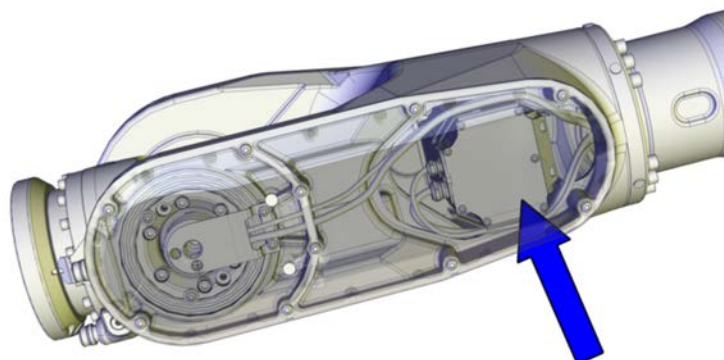

xx1500001899

Spare part

Spare part	Spare part number	Note
Axis-5 motor	See <i>Product manual, spare parts - IRB 6700/IRB 6700Inv</i>	

Consumables

Equipment, etc.	Article number	Note
Grease	3HAC042536-001	Shell Gadus S2 Used to lubricate o-rings.
O-ring	3HAC054692-001	D=119x3 Used on motor cover.
O-ring	3HAB3772-107	D=102x3 Used on motor flange.

Required tools

Equipment, etc.	Article number	Note
Removal tool motor M12	3HAC14631-1	Used to push out the motor, if necessary. Always use removal tools in pairs.
Long Allen key socket IN19L 6-140	-	Length: 140 mm.
Guide pin, M8x100	3HAC15520-1	Always use guide pins in pairs.
Bits extender	3HAC12342-1	300 mm, bits 1/2"
Rotation tool	3HAB7887-1	Used to rotate the motor pinion.
24 VDC power supply	-	Used to release the motor brakes.
Leak-down tester	-	

Continues on next page

4 Repair

4.7.5 Replacing the axis-5 motor

Continued

Equipment, etc.	Article number	Note
Calibration tool box, Axis Calibration	3HAC055412-001	Delivered as a set of calibration tools.
Standard toolkit	-	Content is defined in section Standard toolkit on page 724 .

Deciding calibration routine

Decide which calibration routine to be used, based on the information in the table. Depending on which routine is chosen, action might be required prior to beginning the repair work of the robot, see the table.

	Action	Note
1	Decide which calibration routine to use for calibrating the robot. <ul style="list-style-type: none">Reference calibration. External cable packages (DressPack) and tools can stay fitted on the robot.Fine calibration. All external cable packages (DressPack) and tools must be removed from the robot.	
	If the robot is to be calibrated with reference calibration: Find previous reference values for the axis or create new reference values. These values are to be used after the repair procedure is completed, for calibration of the robot. If no previous reference values exist, and no new reference values can be created, then reference calibration is not possible.	Follow the instructions given in the reference calibration routine on the FlexPendant to create reference values. Creating new values requires possibility to move the robot. Read more about reference calibration for Axis Calibration in Reference calibration routine on page 695 .
	If the robot is to be calibrated with fine calibration: Remove all external cable packages (DressPack) and tools from the robot.	



Removing the axis-5 motor

Use these procedures to remove the motor.

Preparations before removing the axis-5 motor

	Action	Note
1	Decide which calibration routine to use, and take actions accordingly prior to beginning the repair procedure.	
2	Jog the robot to this position: <ul style="list-style-type: none">Axis 2: 0°Axis 3: To a suitable working position for the operator to remove axis-5 motor.	

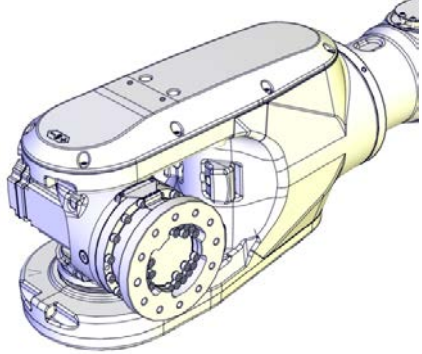
Continues on next page

	Action	Note
3	Jog axis 4 to this position: <ul style="list-style-type: none"> • Axis 4: +90° 	With the robot in this position, there is no need to drain oil from the axis-5 gearbox when the motor is replaced.  xx140000719
4	 DANGER Turn off all: <ul style="list-style-type: none"> • electric power supply • hydraulic pressure supply • air pressure supply to the robot, before entering the safeguarded space.	

Retrieving access to the wrist cabling

Use this procedure to remove the wrist cover to retrieve access to the axis-5 and axis-6 motor cables.

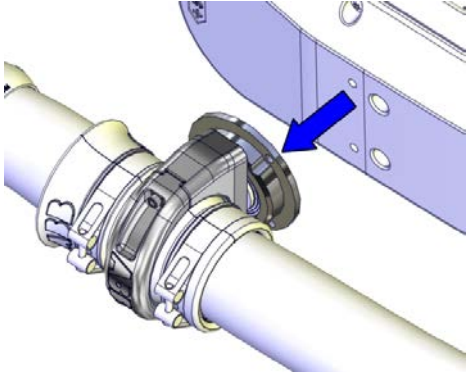
	Action	Note
1	 DANGER Make sure that all supplies for electrical power, hydraulic pressure, and air pressure are turned off.	
2	If DressPack is installed: <ul style="list-style-type: none"> • Remove the bracket with the complete ball joint housing still fitted, as shown in the figure. This is done to be able to reach the two hidden screws that secure the wrist cover.	 xx140000355

Continues on next page



4 Repair

4.7.5 Replacing the axis-5 motor

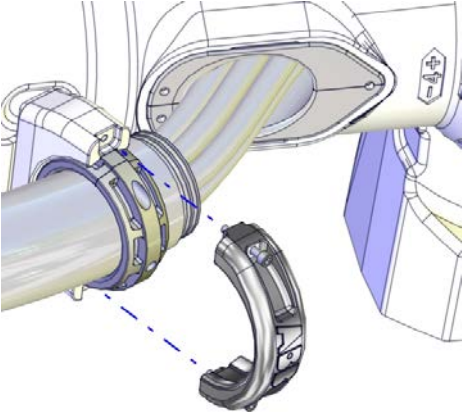
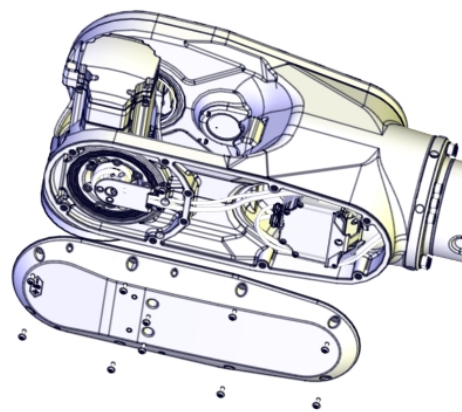
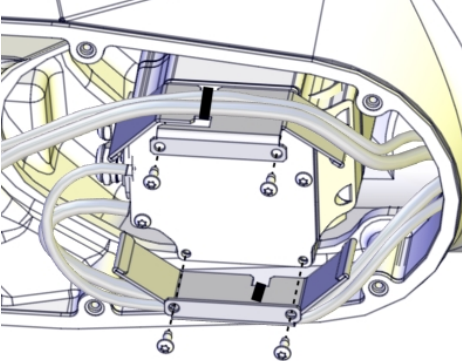
Continued

	Action	Note
3	If used, open the ball joint housing on the arm tube and remove the DressPack cable package.	 xx140000206
4	Remove the wrist cover.	 xx1300002247
5	Remove the heat protection plates from the motor with the cabling still attached to the plate.	 xx1500001030

Continues on next page

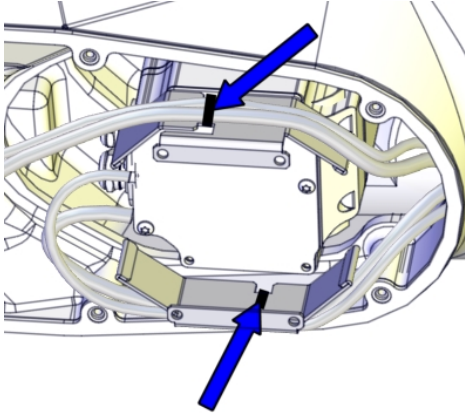
	Action	Note
6	<p>Cut the cable ties that hold the cable harness to the plate.</p> <p> Note Keep the heat protection plate until refitting.</p> <p> Tip If removing the plate only for replacing the motor, the cabling does not need to be loosened from the plate.</p>	 <p>xx1500001029</p>

Disconnecting the motor cables

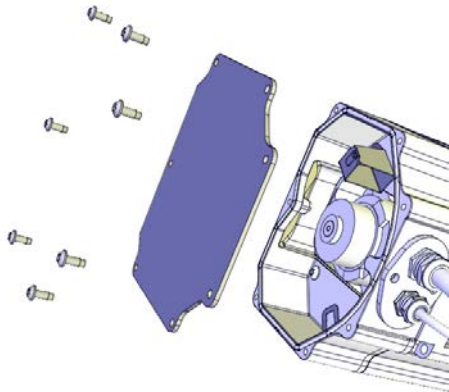

	Action	Note
1	<p> DANGER Make sure that all supplies for electrical power, hydraulic pressure, and air pressure are turned off.</p>	
2	<p>Unscrew the attachment screws and washers and remove the motor cover.</p>	 <p>xx1200001135</p>

Continues on next page

4 Repair

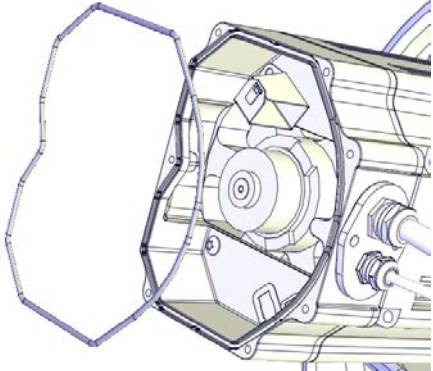
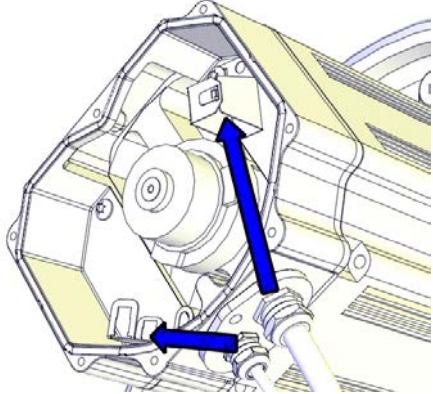

4.7.5 Replacing the axis-5 motor

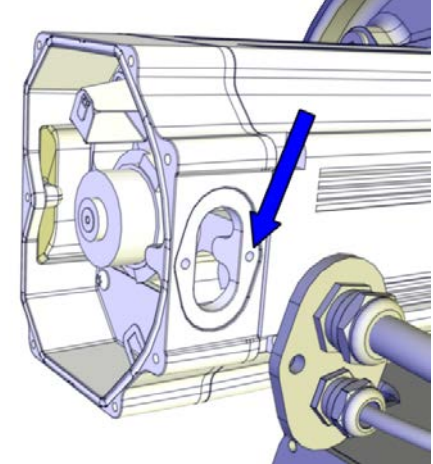
Continued

	Action	Note
3	Make sure the o-ring is present.	 xx1200001070
4	Disconnect the motor cables.	 xx1200001066
5	<p>Remove the cable gland cover by performing the following steps:</p> <ol style="list-style-type: none">1 Open the inner screw a little (the one the arrow is pointing at). No need to remove this screw from the motor.2 Remove the outer screw.3 Slide the cable gland cover away from the inner screw. Make sure the gasket is not damaged. <p> Tip</p> <p>Make a note in which direction the cable exit hole is facing, if the motor will be removed too. The motor shall be refitted in the same position.</p>	 xx1300000656
6	Use caution and pull out the motor cables.	

Continues on next page

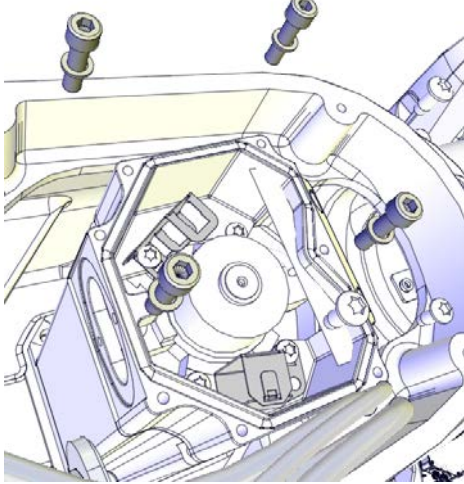
Removing the axis-5 motor

	Action	Note
1	Unscrew the attachment screws that secure the motor, using a bits extender.	Bits extender: 3HAC12342-1  <small>xx1200001017</small>
2	 CAUTION Whenever parting/mating motor and gear-box, the gears may be damaged if excessive force is used.	
3	If needed, fit removal tools in opposite holes.	Removal tool motor M12: 3HAC14631-1 Always use removal tools in pairs.
4	 CAUTION The motor weighs 12 kg. All lifting accessories used must be sized accordingly.	

Continues on next page

4 Repair

4.7.5 Replacing the axis-5 motor

Continued

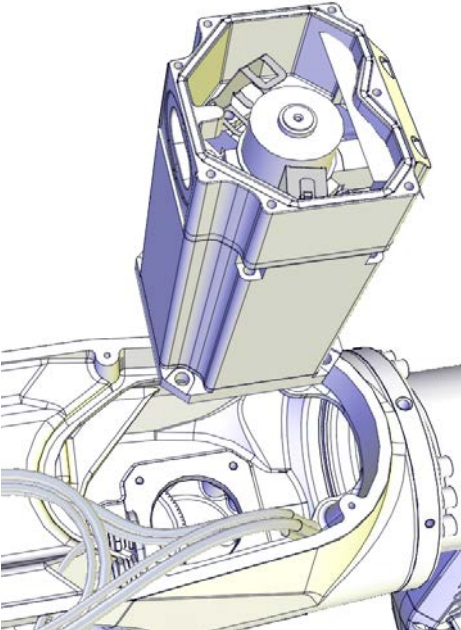
	Action	Note
5	Use caution and lift the motor out. Be careful not to damage the pinion.	 xx1200001018

Refitting the axis-5 motor

The procedures describe how to refit the motor.

Preparations before refitting the axis-5 motor

	Action	Note
1	 DANGER Turn off all: <ul style="list-style-type: none">• electric power supply• hydraulic pressure supply• air pressure supply to the robot, before entering the safeguarded space.	

Continues on next page

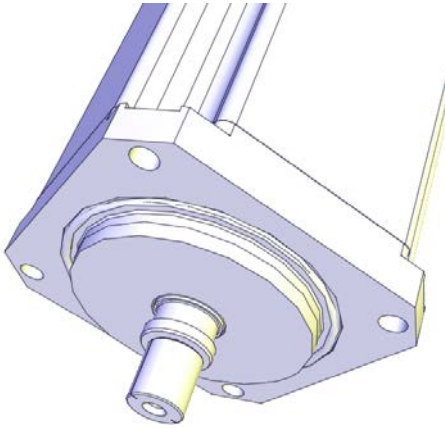
	Action	Note
2	Wipe clean the contact surfaces from any contamination. Also wipe clean the o-ring groove.	 <p>xx1200001019</p>
3	Check the o-ring. Replace if damaged.	O-ring, 3HAB3772-107
4	Lubricate the o-ring with some grease.	
5	Make sure the o-ring is seated in the groove.	 <p>xx1200001020</p>
6	Apply two guide pins in opposite holes.	Guide pin, M8x100: 3HAC15520-1

Securing the axis-5 motor

	Action	Note
1	 CAUTION Whenever parting/mating motor and gear-box, the gears may be damaged if excessive force is used.	

Continues on next page

4 Repair

4.7.5 Replacing the axis-5 motor

Continued

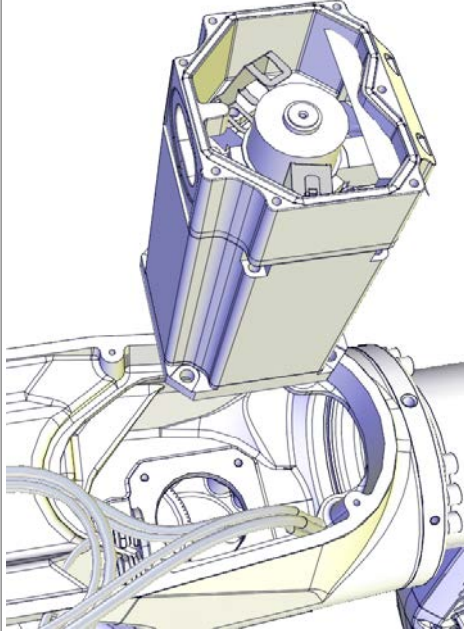
	Action	Note
2	Apply the rotation tool and use it to rotate the pinion when mating it into the gear.	Rotation tool: 3HAB7887-1
3	To release the brakes, connect the 24 VDC power supply. Connect to connector R2.MP5: <ul style="list-style-type: none">• + = pin 2• - = pin 5	24 VDC power supply
4	 CAUTION The motor weighs 12 kg. All lifting accessories used must be sized accordingly.	
5	Use caution and lower the motor into position on the guide pins, while at the same time rotating the motor pinion slightly. Make sure that: <ul style="list-style-type: none">• the motor pinion is properly mated to the gear of the gearbox.• the motor pinion does not get damaged.• the direction of the cable exit is facing the same way as before removal.	Rotation tool, 3HAB7887-1  xx1200001018
6	Remove the guide pins.	

Continues on next page

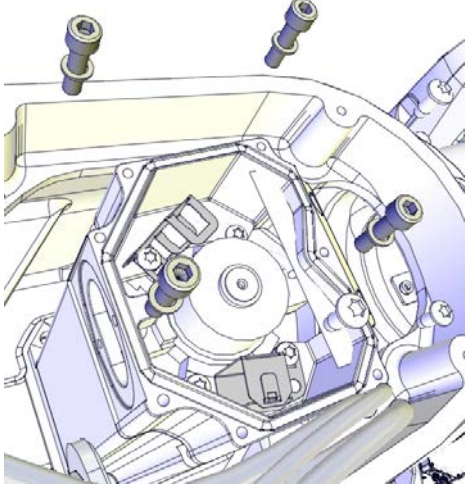
	Action	Note
7	Secure the motor with its attachment screws and washers.	<p>Tightening torque: 24 Nm. Screw dimension: M8x30 quality 12.9 Gleitmo(4 pcs)</p>  <p>xx1200001017</p>
8	Perform a leak-down test.	See Performing a leak-down test on page 188 .
9	Disconnect the 24 VDC power supply.	

Connecting the motor cables

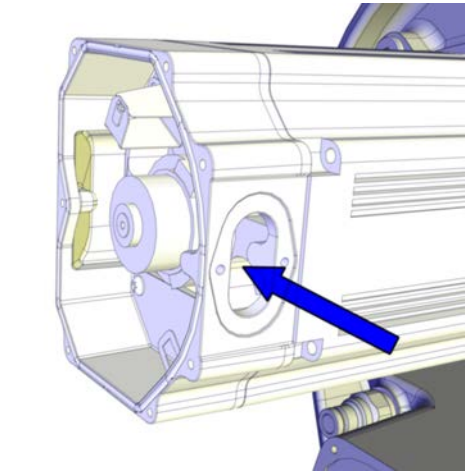

	Action	Note
1	Push the motor cables in through the cable gland opening.	 <p>xx1300000738</p>

Continues on next page

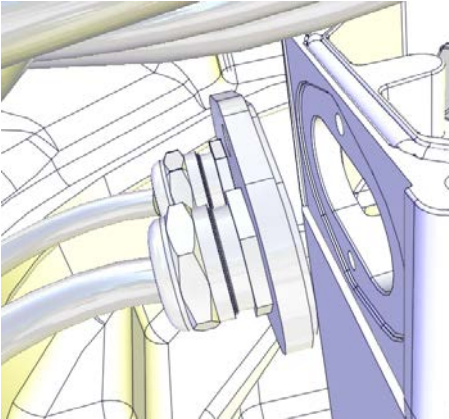
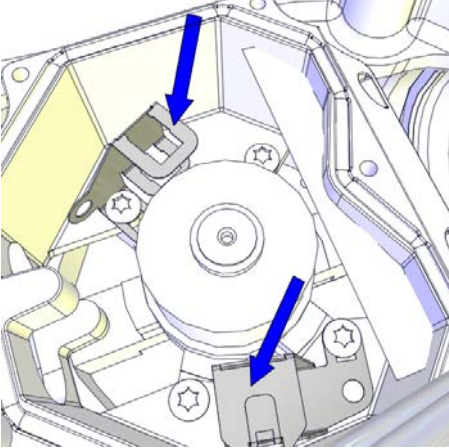
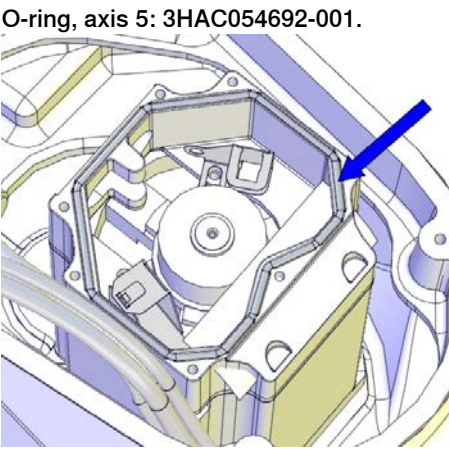

4 Repair

4.7.5 Replacing the axis-5 motor

Continued

	Action	Note
2	<p>Refit the cable gland cover by performing the following steps:</p> <ul style="list-style-type: none">• Slide the cable gland cover onto the inner screw.• Refit and tighten the outer screw.• Tighten the inner screw. Make sure that the gasket is not damaged. <p> Note</p> <p>Replace the gasket if damaged.</p>	 <p>xx1200001016</p>
3	<p>Connect the connectors.</p> <p>Connect in accordance with the markings on the connectors.</p>	 <p>xx1200001015</p>
4	<p>Make sure the o-ring on the motor is undamaged.</p> <p>Replace if damaged.</p>	<p>O-ring, axis 5: 3HAC054692-001.</p>  <p>xx1200001021</p>
5	<p> CAUTION</p> <p>When fitting the motor cover, make sure that none of the cables inside will be damaged.</p>	

Continues on next page

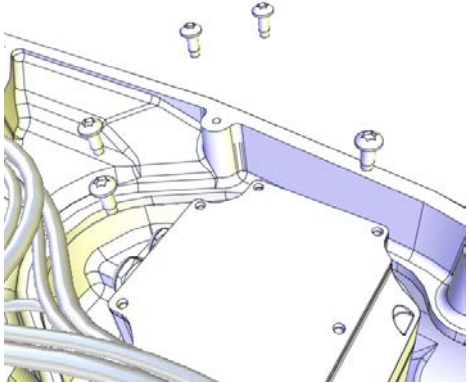
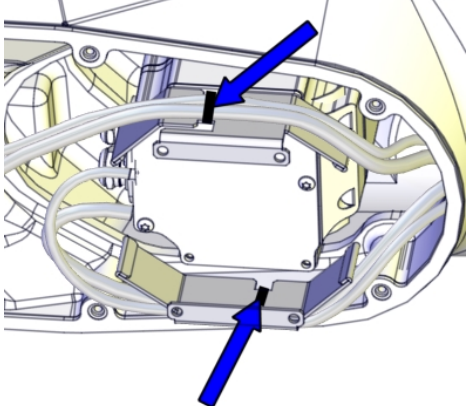
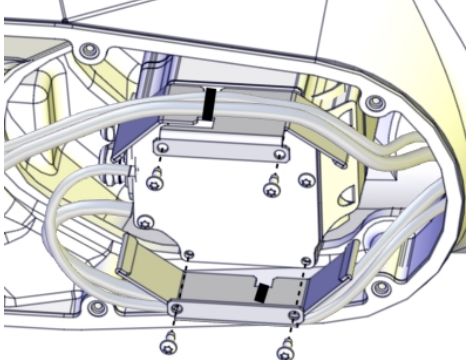
	Action	Note
6	<p>Refit the motor cover with its attachment screws.</p> <p> Note</p> <p>Do not refit the screws that will hold the heat protection plate at this point.</p> <p> Note</p> <p>Do not reuse the self-threading attachment screws, it will damage the threads. Replace with standard attachment screws.</p> <p> Note</p> <p>Make sure the o-ring is undamaged and properly fitted.</p>	<p>Screws: M5x12.</p>  <p>xx1200001013</p>
7	<p>Secure the cable harness with cable straps to the heat protection plate.</p>	 <p>xx1500001029</p>
8	<p>Fit the heat protection plate with the screws.</p>	<p>Screws: M5x12.</p>  <p>xx1500001030</p>

Continues on next page

4 Repair

4.7.5 Replacing the axis-5 motor

Continued

Concluding procedure

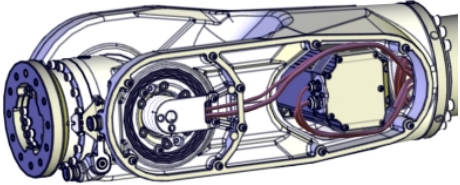
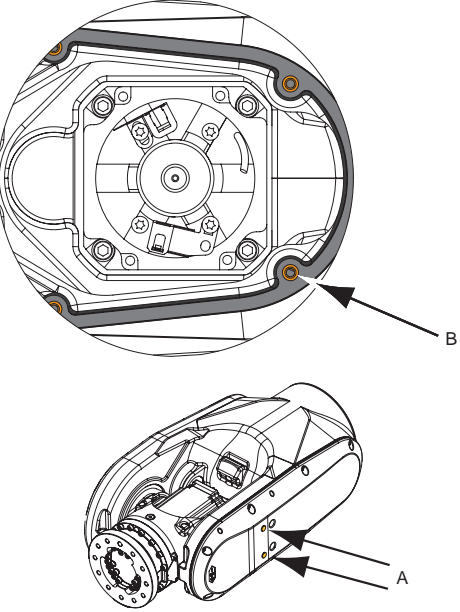
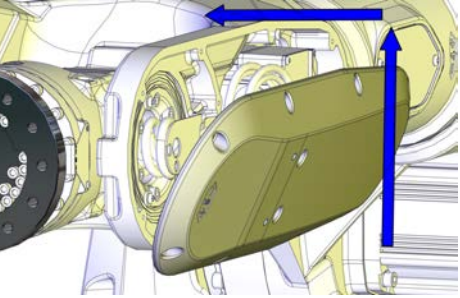
	Action	Note
1	Make sure that the cable harness is placed in a way that it will not be damaged when the wrist cover is fitted.	 <p>xx1500001672</p>
2	<p>Foundry Plus: Inspect the gasket. Replace if damaged. Put washers in the holes of the gasket.</p>	 <p>xx1400000383</p> <p>A Protection plugs (2 on wrist cover and 2 on cover axis-5 gearbox) B Washers (10 pcs) in gasket holes</p>
3	<p>Refit the wrist cover. In order not to damage the cable harness when the wrist cover is refitted, use this method:</p> <ol style="list-style-type: none"> 1 Hold the cover slightly tilted below the wrist. 2 Put the cable harness inside the cover. 3 Lift the cover, still tilted. 4 Move the upper part of the cover into position. 5 Secure the cover with its attachment screws. 	 <p>xx1300000772</p> <p>Tightening torque: 10 Nm</p>
4	<p>Foundry Plus: Refit protection plugs.</p>	
5	If used, refit the DressPack cable package on the wrist.	

Continues on next page

	Action	Note
6	Re-calibrate the robot.	Axis Calibration is described in Calibrating with Axis Calibration method on page 694 . General calibration information is included in section Calibration on page 683 .
7	 DANGER Make sure all safety requirements are met when performing the first test run. See Test run after installation, maintenance, or repair on page 97 .	

4 Repair

4.7.6 Replacing the axis-6 motor

4.7.6 Replacing the axis-6 motor

Location of axis-6 motor

The axis-6 motor is located as shown in the figure.

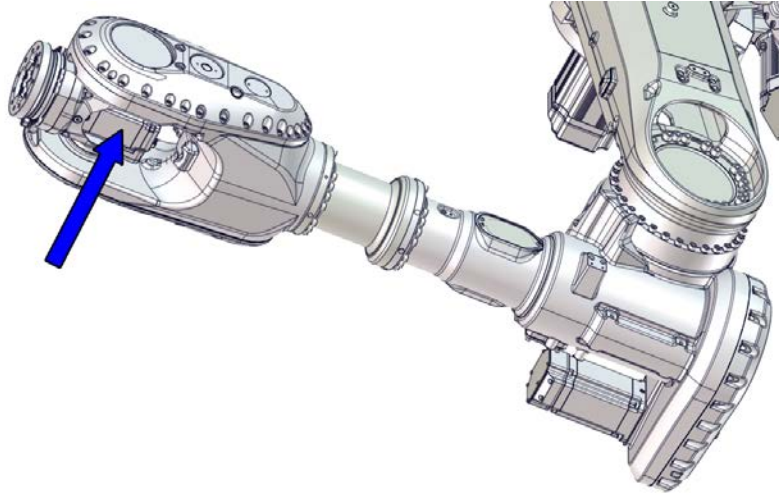

xx170000463

Spare part

Spare part	Spare part number	Note
Axis-6 motor	See <i>Product manual, spare parts - IRB 6700/IRB 6700Inv</i>	

Consumables

Equipment, etc.	Article number	Note
Grease	3HAC042536-001	Shell Gadus S2 Used to lubricate o-rings.
Gasket	3HAC033489-001	Used on motor cover.
O-ring	3HAB3772-107	D=102x3 Used on motor flange.

Required tools and equipment

Equipment, etc.	Article number	Note
Removal tool motor M12	3HAC14631-1	Used to push out the motor, if necessary. Always use removal tools in pairs.
Rotation tool	3HAB7887-1	Used to rotate the motor pinion.
24 VDC power supply	-	Used to release the motor brakes.
Leak-down tester	-	
Calibration tool box, Axis Calibration	3HAC055412-001	Delivered as a set of calibration tools.

Continues on next page

Equipment, etc.	Article number	Note
Standard toolkit	-	Content is defined in section Standard toolkit on page 724 .

Deciding calibration routine

Decide which calibration routine to be used, based on the information in the table. Depending on which routine is chosen, action might be required prior to beginning the repair work of the robot, see the table.

	Action	Note
1	Decide which calibration routine to use for calibrating the robot. <ul style="list-style-type: none"> Reference calibration. External cable packages (DressPack) and tools can stay fitted on the robot. Fine calibration. All external cable packages (DressPack) and tools must be removed from the robot. 	
	If the robot is to be calibrated with reference calibration: Find previous reference values for the axis or create new reference values. These values are to be used after the repair procedure is completed, for calibration of the robot. If no previous reference values exist, and no new reference values can be created, then reference calibration is not possible.	Follow the instructions given in the reference calibration routine on the FlexPendant to create reference values. Creating new values requires possibility to move the robot. Read more about reference calibration for Axis Calibration in Reference calibration routine on page 695 .
	If the robot is to be calibrated with fine calibration: Remove all external cable packages (DressPack) and tools from the robot.	

Removing the axis-6 motor

Use these procedures to remove the motor.

Preparations before removing the axis-6 motor



	Action	Note
1	Decide which calibration routine to use, and take actions accordingly prior to beginning the repair procedure.	

Continues on next page

4 Repair

4.7.6 Replacing the axis-6 motor

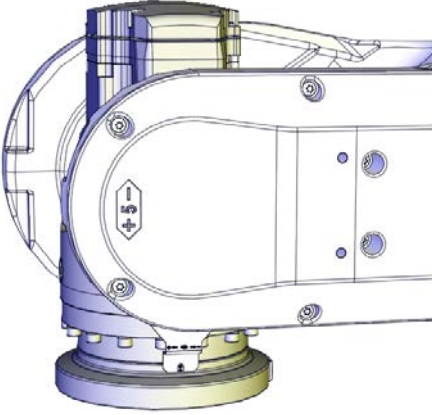
Continued

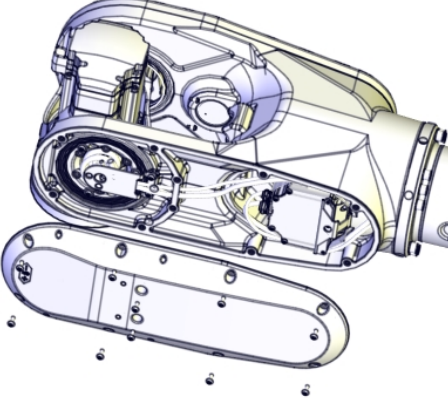
	Action	Note
2	<p>Jog the robot to a position where axis 5 can be positioned with the motor pointing straight up at an acceptable working position.</p> <p>With axis 5 in this position it is possible to replace the motor without draining the oil from the axis-6 gearbox.</p>	 <p>xx1200001081</p>
3	<p> DANGER</p> <p>Turn off all:</p> <ul style="list-style-type: none"> • electric power supply • hydraulic pressure supply • air pressure supply <p>to the robot, before entering the safeguarded space.</p>	
4	<p>Remove the wrist cover.</p>	 <p>xx1300002247</p>

Disconnecting the axis-6 motor cables

	Action	Note
1	<p> DANGER</p> <p>Make sure that all supplies for electrical power, hydraulic pressure, and air pressure are turned off.</p>	

Continues on next page

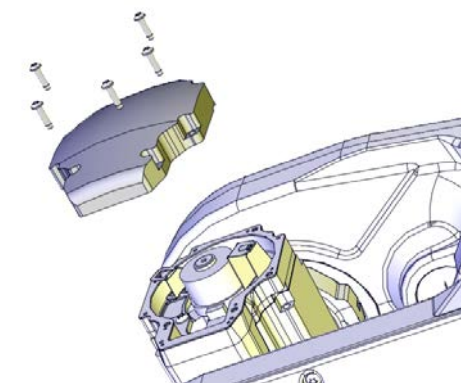
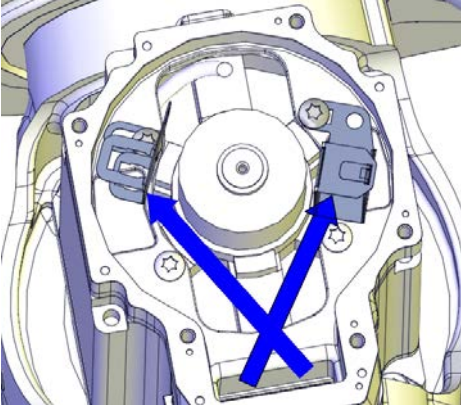
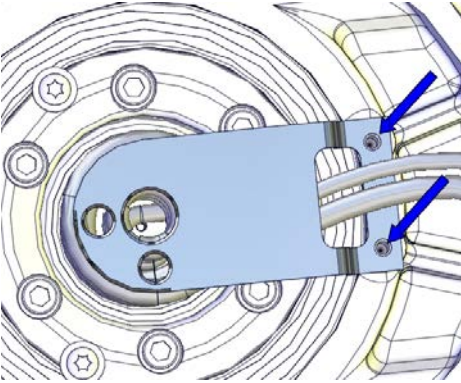
	Action	Note
2	Unscrew the attachment screws and remove the motor cover.	 <p>xx1200001080</p>
3	Disconnect the motor cables.	 <p>xx1300000488</p>
4	Unscrew the attachment screws that hold the cable bracket.	 <p>xx1300000484</p>

Continues on next page

4 Repair

4.7.6 Replacing the axis-6 motor

Continued

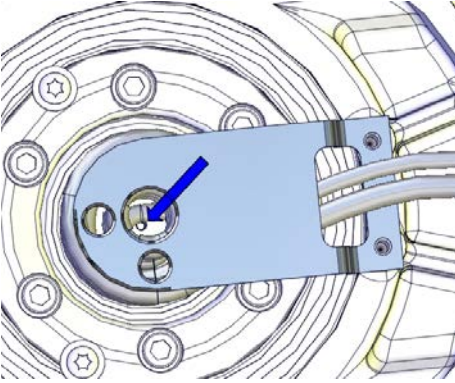
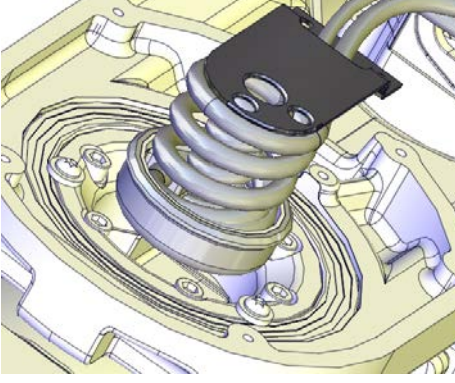
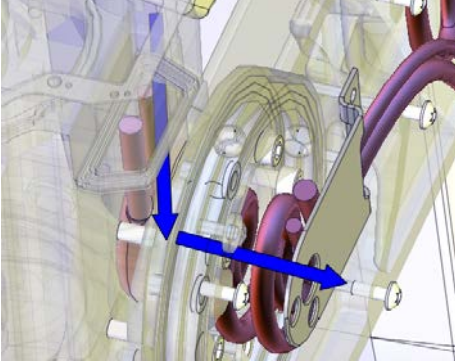
	Action	Note
5	<p>Unscrew the M4 screw that holds the carrier.</p> <p> Note</p> <p>The screw is located at the bottom of the carrier.</p>	 <p>xx1300000485</p>
6	<p>Pull out the carrier from its position.</p>	 <p>xx1300001113</p>
7	<p>Pull out the axis-6 motor cables by holding the cables with one hand at the motor and the other at the carrier.</p>	 <p>xx1300000666</p>

Removing the axis-6 motor

	Action	Note
1	<p>To release the brakes, connect the 24 VDC power supply.</p> <p>Connect to R2.MP6-connector:</p> <ul style="list-style-type: none"> • + = pin 2 • - = pin 5 	<p>24 VDC power supply</p>

Continues on next page

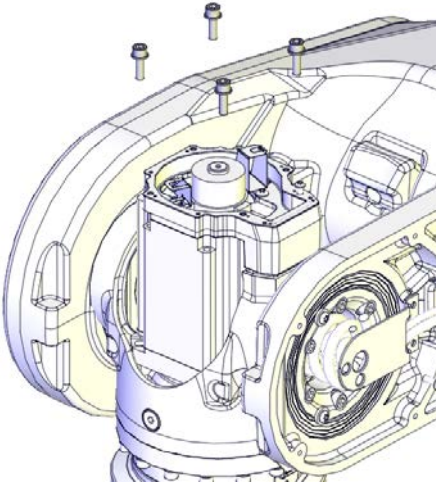
	Action	Note
2	Unscrew the motor attachment screws.	 <p>xx1200001090</p>
3	<p>! CAUTION</p> <p>Whenever parting/mating motor and gear-box, the gears may be damaged if excessive force is used.</p>	
4	If required, press the motor out of position by fitting the removal tool, motor to the attachment holes of the motor.	Removal tool motor M12: 3HAC14631-1 Always use removal tools in pairs.
5	<p>! CAUTION</p> <p>The motor weighs 9 kg. All lifting accessories used must be sized accordingly.</p>	

Continues on next page

4 Repair

4.7.6 Replacing the axis-6 motor

Continued

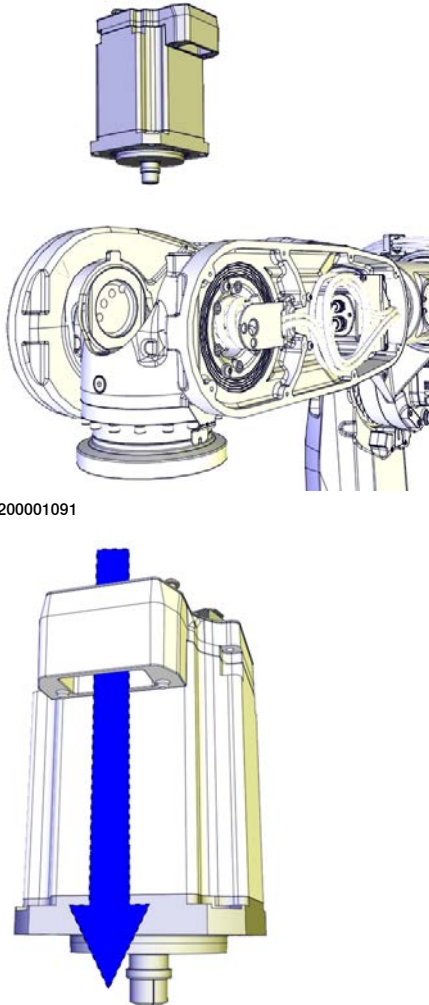
	Action	Note
6	<p>Remove the motor by lifting it straight up from the gear while at the same time picking out the motor cables from the motor. Make sure the motor pinion is not damaged!</p>	 <p>xx1200001091</p> <p>xx1200001096</p>
7	<p>Disconnect the 24 VDC power supply.</p>	



Refitting the axis-6 motor

Use this procedure to refit the motor.

Preparations prior to refitting motor

	Action	Note
1	 <p>DANGER</p> <p>Make sure that all supplies for electrical power, hydraulic pressure, and air pressure are turned off.</p>	

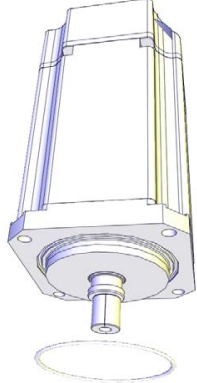

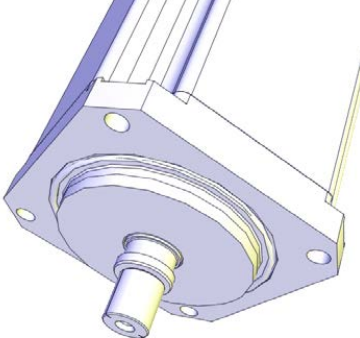
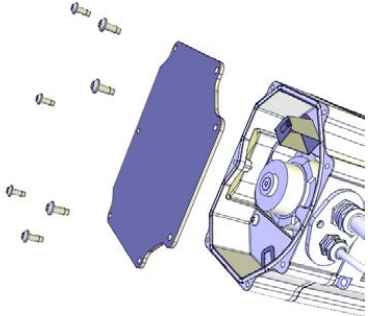
Continues on next page

	Action	Note
2	<p>Remove any old paint residues or other contamination from the contact surfaces on both the motor and the mating parts. Wipe clean the contact surfaces and the o-ring groove.</p>	
3	<p>Fit a new o-ring.</p>	 <p>xx1200001019</p>
4	<p>Make sure the o-ring is seated in the groove.</p> <p> Tip Lubricate the o-ring with some grease for a better fitting in the groove.</p>	 <p>xx1200001020</p>
5	<p>If the motor is a new spare part, remove the cover.</p>	 <p>xx1200001135</p>



4 Repair

4.7.6 Replacing the axis-6 motor

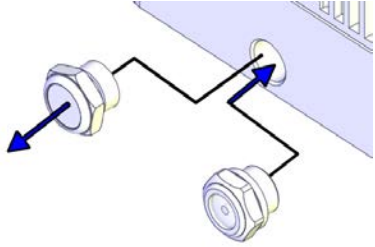

Continued

	Action	Note
6	<p>Protection type Foundry Plus Valid for axis-2, axis-3, axis-4 and axis-6 motors. If the motor is a new spare part, the evacuation hole protection filter must be replaced with a transparent plug/sight glass (enclosed with the spare part delivery). Remove the protection filter and install the transparent plug/sight glass. On the axis-6 motor there are two protection filters that must be replaced with transparent plugs/sight glasses.</p> <div style="display: flex; justify-content: space-around;"> <div style="text-align: center;">  <p>xx2200002188 Transparent plug (Foundry Plus).</p> </div> <div style="text-align: center;">  <p>xx1800000101 Protection filter (Standard).</p> </div> </div>	<p>Tightening torque, transparent plug: 20 Nm \pm10% Tightening torque, protection filter: 10 Nm \pm10%</p>  <p>xx1600000576</p>

Securing the axis-6 motor

	Action	Note
1	 <p>DANGER</p> <p>Make sure that all supplies for electrical power, hydraulic pressure, and air pressure are turned off.</p>	
2	<p>To release the brakes, connect the 24 VDC power supply. Connect to connector R2.MP6:</p> <ul style="list-style-type: none"> • + = pin 2 • - = pin 5 	
3	 <p>CAUTION</p> <p>Whenever parting/mating motor and gear-box, the gears may be damaged if excessive force is used.</p>	

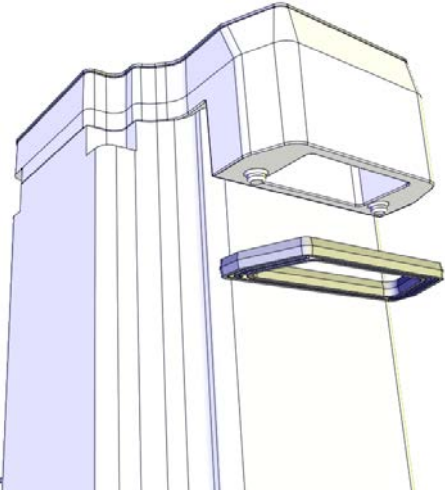
Continues on next page

	Action	Note
4	<p>Check the gasket. Replace if damaged.</p>	 <p>xx1200001094</p>
5	<p> CAUTION</p> <p>The motor weighs 9 kg. All lifting accessories used must be sized accordingly.</p>	



4 Repair

4.7.6 Replacing the axis-6 motor

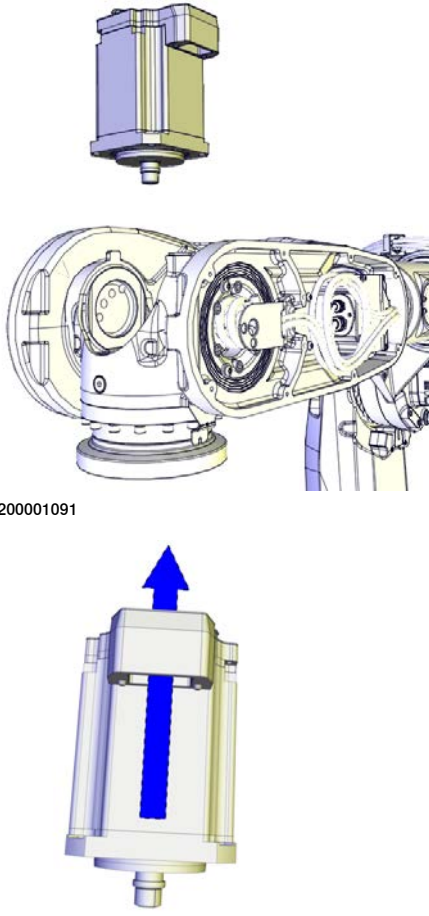
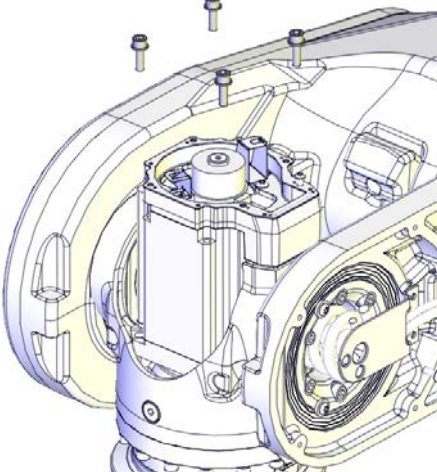
Continued

	Action	Note
6	<p>Fit the motor while, at the same, time pushing the motor cables in through the cable gland.</p> <p>Make sure the motor pinion is properly mated with the gear of the axis-6 gearbox.</p> <p>Make sure the motor pinion is not damaged!</p>	 <p>xx1200001091</p> <p>xx1200001097</p>
7	<p>Check that the gasket is fitted correctly.</p> <p>Secure the motor with its attachment screws.</p>	<p>Screws: M8x25 Steel 8.8-A2F (4 pcs)</p> <p>Tightening torque: 24 Nm</p>  <p>xx1200001090</p>

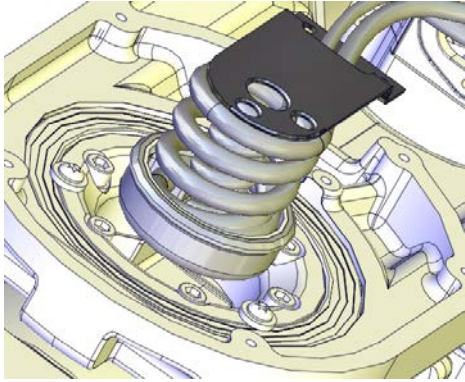
Continues on next page

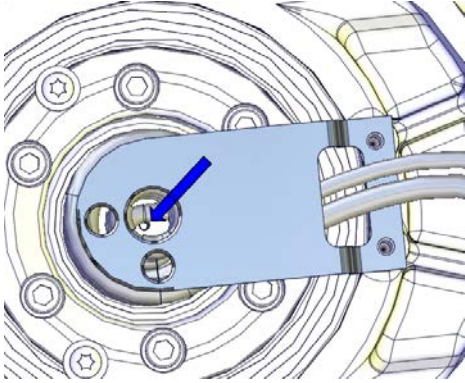
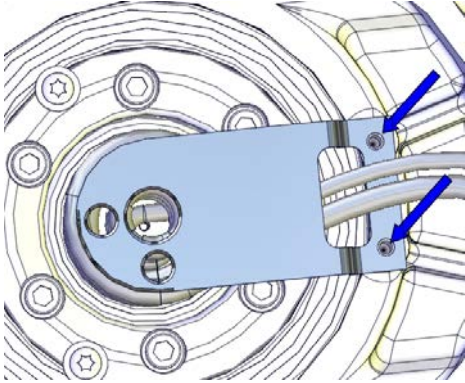
	Action	Note
8	Refit the axis-6 motor cables by carefully pushing them and the carrier into position.	 <p>xx1300001113</p>
9	Tighten the M4 screw that holds the carrier.  Note The screw is located at the bottom of the carrier.	 <p>xx1300000485</p>
10	Refit the cable bracket.	 <p>xx1300000484</p>
11	Perform a leak-down test.	See Performing a leak-down test on page 188 .
12	Disconnect the 24 V DC power supply.	

Continues on next page

4 Repair

4.7.6 Replacing the axis-6 motor

Continued

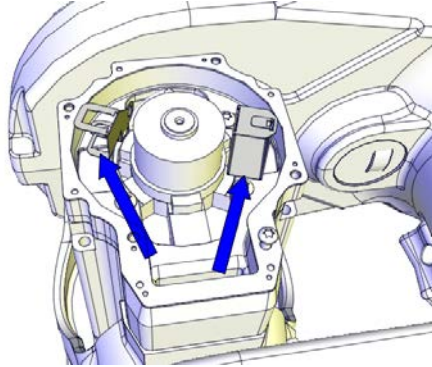
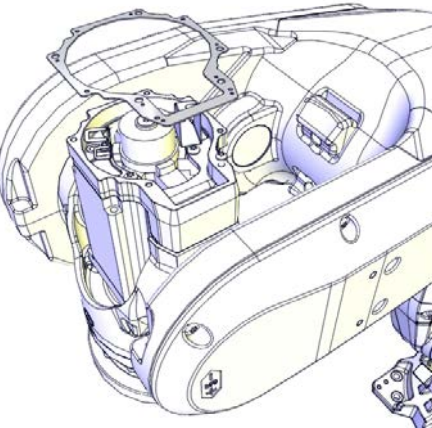
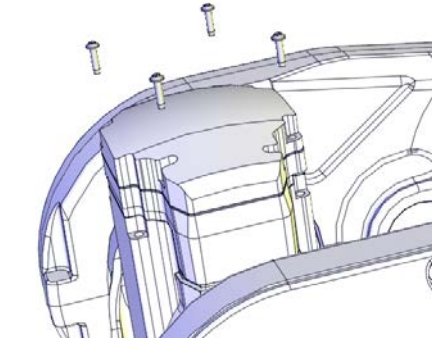
	Action	Note
13	Reconnect the connectors.	 xx1200001084
14	Check the gasket. Replace if damaged.	Gasket: 3HAC033489-001  xx1200001095
15	Refit the motor cover.	 xx1200001082

Continues on next page

Concluding procedure

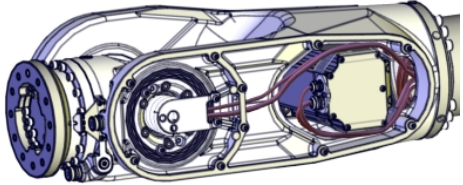
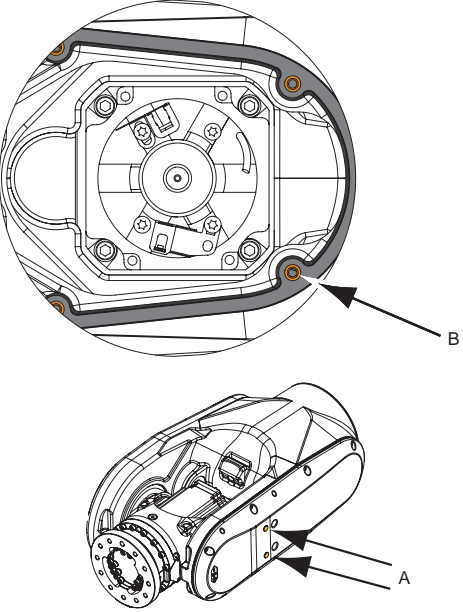
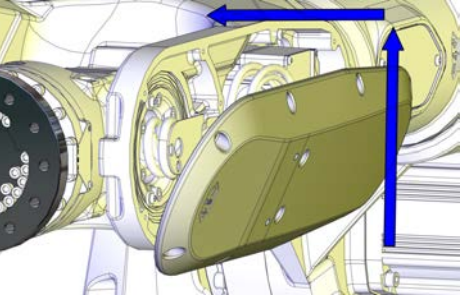
	Action	Note
1	<p>Make sure that the cable harness is placed in a way that it will not be damaged when the wrist cover is fitted.</p>	 <p>xx1500001672</p>
2	<p>Foundry Plus: Inspect the gasket. Replace if damaged. Put washers in the holes of the gasket.</p>	 <p>xx1400000383</p> <p>A Protection plugs (2 on wrist cover and 2 on cover axis-5 gearbox) B Washers (10 pcs) in gasket holes</p>
3	<p>Refit the wrist cover. In order not to damage the cable harness when the wrist cover is refitted, use this method:</p> <ol style="list-style-type: none"> 1 Hold the cover slightly tilted below the wrist. 2 Put the cable harness inside the cover. 3 Lift the cover, still tilted. 4 Move the upper part of the cover into position. 5 Secure the cover with its attachment screws. 	 <p>xx1300000772</p> <p>Tightening torque: 10 Nm</p>
4	<p>Foundry Plus: Refit protection plugs.</p>	
5	<p>If used, refit the DressPack cable package on the wrist.</p>	

Continues on next page

4 Repair

4.7.6 Replacing the axis-6 motor

Continued

	Action	Note
6	Re-calibrate the robot.	Axis Calibration is described in Calibrating with Axis Calibration method on page 694 . General calibration information is included in section Calibration on page 683 .
7	 DANGER Make sure all safety requirements are met when performing the first test run. See Test run after installation, maintenance, or repair on page 97 .	

4.8 Gearboxes

4.8.1 Replacing the hub

Location of the hub

The hub is located as shown in the figure.

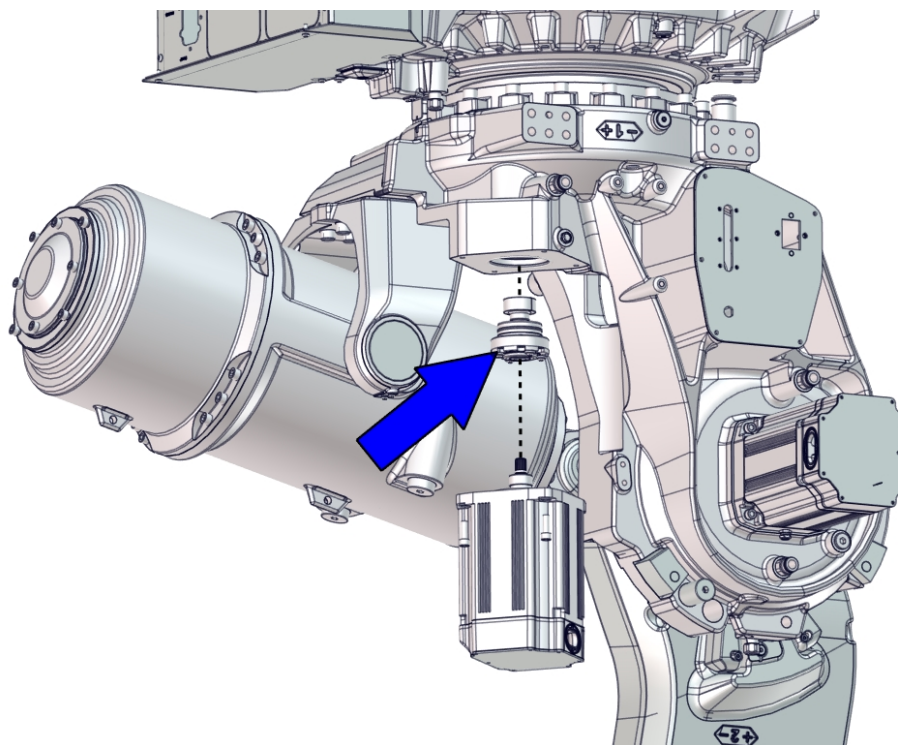

xx170000462

Summary of the replacement procedure

This is a brief summary of the replacement procedure, containing the major actions to be performed.

- 1 Drain the oil in axis 1.
- 2 Remove the axis-1 motor.
- 3 Replace the hub.
- 4 Refit the axis-1 motor.
- 5 Fill oil in axis 1.

Required spare parts

Spare part	Article number	Note
Hub with pinion	3HAC058203-003	

Continues on next page

4 Repair

4.8.1 Replacing the hub

Continued

Required tools and equipment

Equipment	Article number	Note
Oil collecting vessel	-	The capacity of the vessel must be sufficient to take the complete amount of oil.
Oil dispenser	-	One example of oil dispenser can be found in section Type of lubrication in gearboxes on page 147 .
Oil level gauge	3HAC061881-001	Assemble the extender to be able to use the oil level gauge when the fork lift accessories are mounted. The tool also includes an air vent.
Removal tool axis-1 motor	3HAC062250-001	Used to lower and raise the motor axis-1 (inverted position).
Roundsling, 1 m	-	Lifting capacity: 1,000 kg.
Lifting eye, M12	3HAC16131-1	
Guide pin, M12x150	3HAC13056-2	Always use guide pins in pairs.
Bits extender	3HAC12342-1	300 mm, bits 1/2"
Rotation tool	3HAB7887-1	Used to rotate the motor pinion.
24 VDC power supply	-	Used to release the motor brakes.
Hub tool	3HAC071355-001	Used for removal and refitting of the hub.
Leak-down tester	-	
Calibration tool box, Axis Calibration	3HAC055412-001	Delivered as a set of calibration tools.
Standard toolkit	-	Content is defined in section Standard toolkit on page 724 .

Required consumables

Consumable	Article number	Note
Grease		Castrol Molub. Alloy 777-1 NG

Deciding calibration routine

Decide which calibration routine to be used, based on the information in the table. Depending on which routine is chosen, action might be required prior to beginning the repair work of the robot, see the table.

	Action	Note
1	Decide which calibration routine to use for calibrating the robot. <ul style="list-style-type: none">Reference calibration. External cable packages (DressPack) and tools can stay fitted on the robot.Fine calibration. All external cable packages (DressPack) and tools must be removed from the robot.	



Continues on next page

Action	Note
<p>If the robot is to be calibrated with reference calibration: Find previous reference values for the axis or create new reference values. These values are to be used after the repair procedure is completed, for calibration of the robot. If no previous reference values exist, and no new reference values can be created, then reference calibration is not possible.</p>	<p>Follow the instructions given in the reference calibration routine on the FlexPendant to create reference values. Creating new values requires possibility to move the robot. Read more about reference calibration for Axis Calibration in Reference calibration routine on page 695.</p>
<p>If the robot is to be calibrated with fine calibration: Remove all external cable packages (DressPack) and tools from the robot.</p>	

Removing the hub

Use these procedures to remove the hub.

Draining the axis-1 gearbox

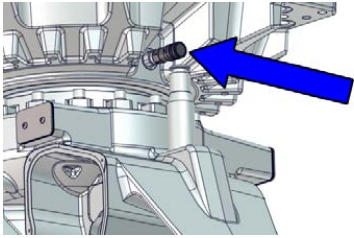

Action	Note
<p>1</p> <p> DANGER</p> <p>Turn off all:</p> <ul style="list-style-type: none"> • electric power supply • hydraulic pressure supply • air pressure supply <p>to the robot, before entering the safeguarded space.</p>	
<p>2</p> <p> WARNING</p> <p>Handling gearbox oil involves several safety risks, see Gearbox lubricants (oil or grease) on page 33.</p>	
<p>3</p> <p>Make sure that the oil temperature is $+25^{\circ}\text{C} \pm 10^{\circ}\text{C}$.</p> <p> CAUTION</p> <p>The gearbox can contain an excess pressure that can be hazardous. Open the oil plug carefully in order to let the excess pressure out.</p>	
<p>4</p> <p>Install the ventilating valve.</p>	 <p>xx1700000349</p>

Continues on next page

4 Repair

4.8.1 Replacing the hub

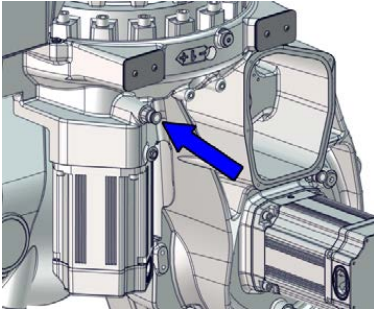
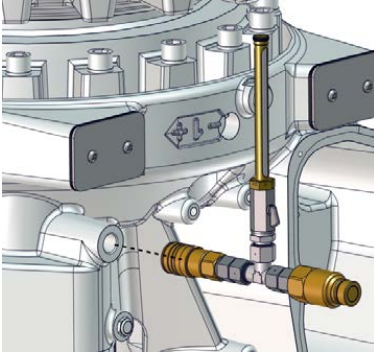
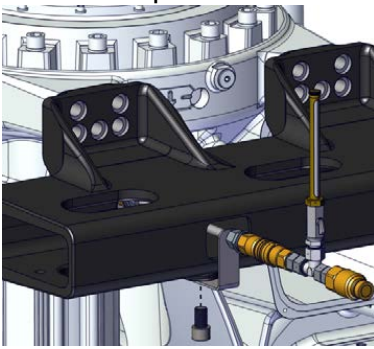
Continued

	Action	Note
5	Remove the protective cap and open the oil plug.	 <p>xx1600002042</p>
6	Make sure that the valve is closed (horizontal) and mount the oil level gauge.	<p>Oil level gauge 3HAC061881-001</p>  <p>xx1600002097</p> <p>If the Fork lift accessory set is assembled, fasten the extender screw in the fork lift pocket.</p>  <p>xx1700000314</p>
7	Open the valve slowly to avoid air bubbles in the oil.	
8	Connect the oil dispenser to the oil level gauge.	
9	Suck out the oil with the oil dispenser.	<p> Note</p> <p>There will be some oil left in the gear after draining.</p>

Continues on next page

	Action	Note
10	 WARNING Used oil is hazardous material and must be disposed of in a safe way. See Decommissioning on page 711 for more information.	
11	Remove the oil dispenser and refit the protective cap on the nipple.	
12	Refit the vent hole plug.	Tightening torque: 24 Nm

Preparations before removing the axis-1 motor

	Action	Note
1	Decide which calibration routine to use, and take actions accordingly prior to beginning the repair procedure.	
2	Jog the robot to the synchronization position.	
3	 DANGER Turn off all: <ul style="list-style-type: none"> • electric power supply • hydraulic pressure supply • air pressure supply to the robot, before entering the safeguarded space.	

Disconnecting the motor cables

	Action	Note
1	 DANGER Make sure that all supplies for electrical power, hydraulic pressure, and air pressure are turned off.	

4 Repair

4.8.1 Replacing the hub

Continued

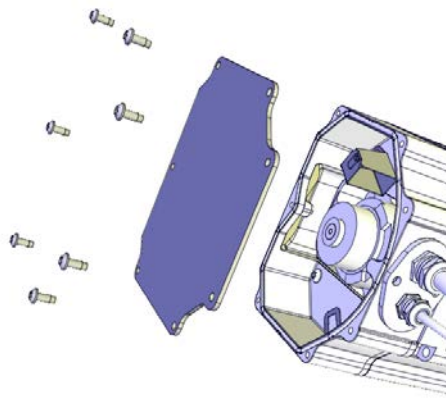
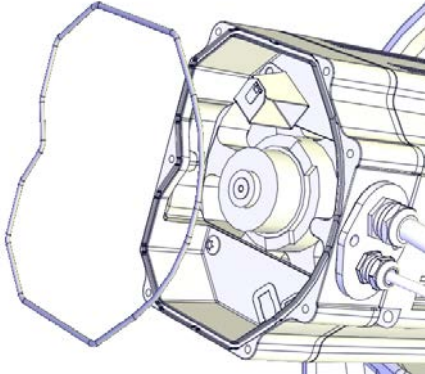
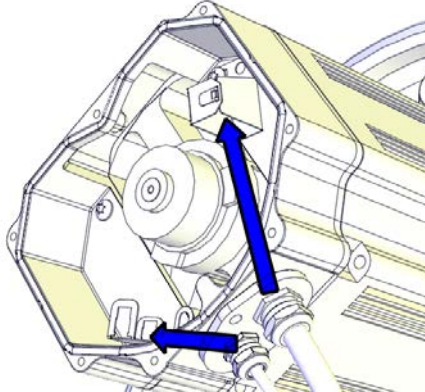
	Action	Note
2	Unscrew the attachment screws and washers and remove the motor cover.	 <p>xx1200001135</p>
3	Make sure the o-ring is present.	 <p>xx1200001070</p>
4	Disconnect the motor cables.	 <p>xx1200001066</p>

Continues on next page

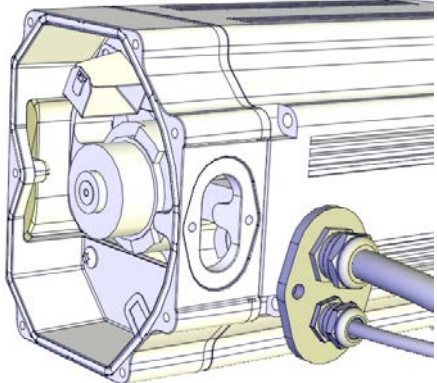
	Action	Note
5	<p>Remove the cable gland cover. Make sure the gasket is not damaged.</p> <p> Tip</p> <p>Make a note in which direction the cable gland hole is facing, if the motor will be removed too. The motor shall be refitted in the same position.</p>	 <p>xx1200001067</p>
6	Use caution and pull out the motor cables.	

Attaching the removal tool

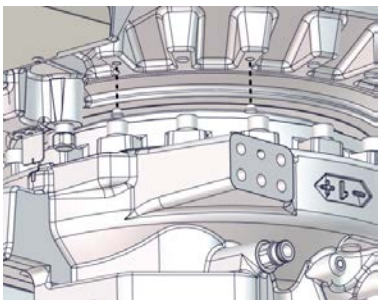
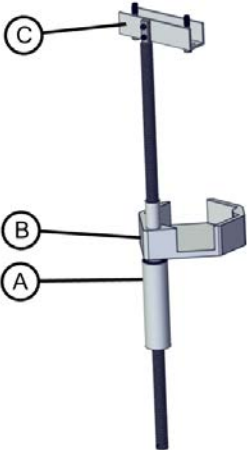
	Action	Note						
1	<p><i>Foundry plus:</i> Remove the plastic plugs.</p>	 <p>xx1700000364</p>						
2	<p>Lower the revolving handle on the removal tool, to be able to fit the shelf beneath the motor while fastening the tool.</p>	 <p>xx1700000365</p> <table border="1" data-bbox="1059 1805 1441 1944"> <tbody> <tr> <td>A</td> <td>Revolving handle</td> </tr> <tr> <td>B</td> <td>Shelf</td> </tr> <tr> <td>C</td> <td>Bracket</td> </tr> </tbody> </table>	A	Revolving handle	B	Shelf	C	Bracket
A	Revolving handle							
B	Shelf							
C	Bracket							

Continues on next page

4 Repair

4.8.1 Replacing the hub

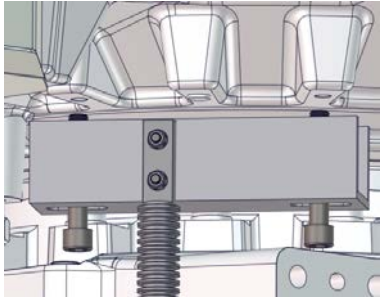

Continued

	Action	Note
3	Attach the tools bracket screws to the robot frame.	 xx1700000366

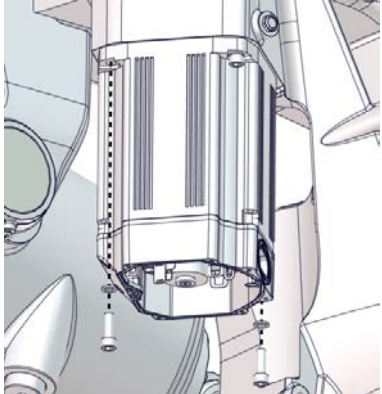
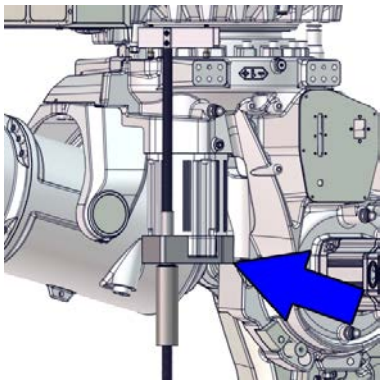
Removing the axis-1 motor

	Action	Note
1	Remove the two shown motor screws and washers.	Bits extender, 3HAC12342-1  xx1700000368
2	Raise the revolving handle to fit the motor on the tool shelf.	 xx1700000367

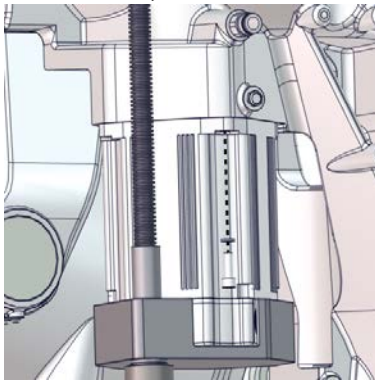
Continues on next page

	Action	Note
3	<p>Remove the two remaining screws holding the motor. (One screw is placed on the opposite side of the motor.)</p> <p> CAUTION</p> <p>Whenever parting/mating motor pinion and hub, the splines may be damaged if excessive force is used.</p>	<p>Bits extender, 3HAC12342-1</p>  <p>xx1700000369</p>
4	<p>To release the brakes, connect the 24 VDC power supply.</p> <p>Connect to R2.MP1-connector:</p> <ul style="list-style-type: none"> • + = pin 2 • - = pin 5 	24 VDC power supply
5	Lower the revolving handle.	If the motor is stuck, use Removal tool motor M12: 3HAC14631-1
6	<p>Rotate the shelf to remove the motor.</p> <p> CAUTION</p> <p>The weight of the motor is 27 kg All lifting accessories used must be sized accordingly.</p>	
7	Disconnect the 24 VDC power supply.	
8	Fasten lifting eyes in two of the fastening holes on the motor.	Lifting eye, M12, 3HAC16131-1
9	Use a roundsling to lift the motor off.	



Removing the hub

	Action	Note
1	<p> DANGER</p> <p>Make sure that all supplies for electrical power, hydraulic pressure, and air pressure are turned off.</p>	

4 Repair

4.8.1 Replacing the hub

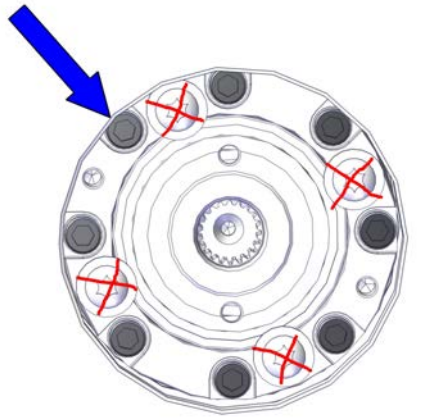
Continued

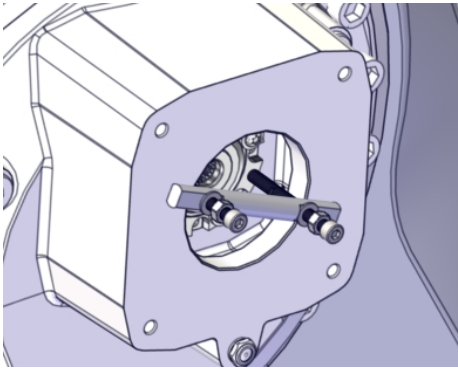
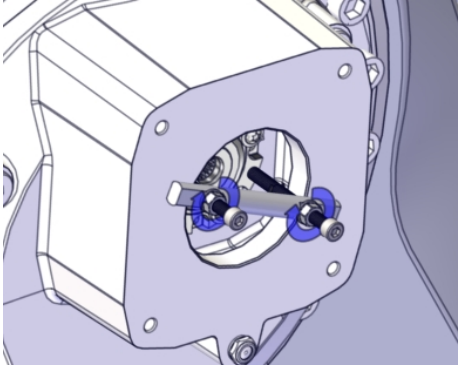
	Action	Note
2	<p>Unscrew the M6x30 hex socket head cap screws that secure the hub.</p> <p> Note</p> <p>Do not remove the M6x16 torx pan head screws.</p>	 <p>xx1500002038</p>
3	<p> CAUTION</p> <p>Whenever parting/mating the hub pinion and gearbox, the gears may be damaged if excessive force is used.</p>	
4	<p>Fit the two threaded rods of the hub tool into the attachment holes in the hub.</p>	<p>Hub tool: 3HAC071355-001</p>  <p>xx2000001379</p>
5	<p>Alternately thread the nuts clockwise on the two rods to pull out the hub from the gear.</p>	 <p>xx2000001380</p>

Continues on next page

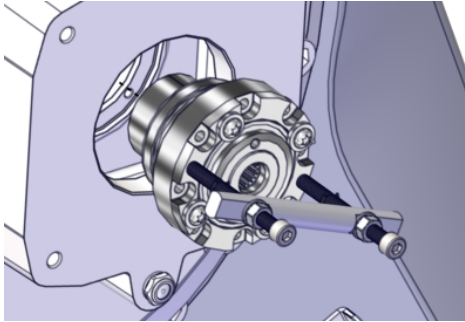
	Action	Note
6	Lift out the hub carefully.	 <p data-bbox="970 636 1078 656">xx2000001381</p>
7	Cover the hole to avoid getting debris into the gearbox during remaining service work.	

Refitting the hub

Use these procedures to refit the hub.

Preparations before refitting the hub

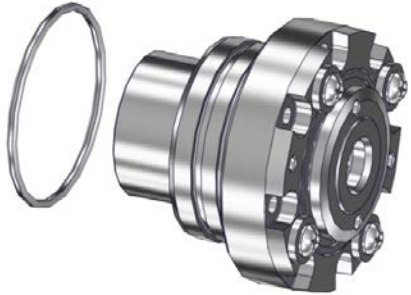
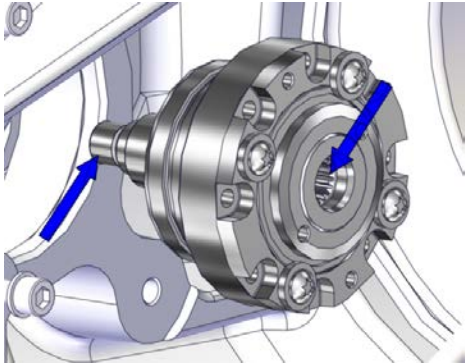
	Action	Note
1	Wipe the hub clean.	
2	Inspect the hole where the hub shall be refitted. Wipe clean if needed.	
3	<p data-bbox="497 1102 960 1167">Make sure the o-ring on the hub is undamaged.</p> <div data-bbox="497 1178 647 1238">  Note </div> <p data-bbox="497 1249 727 1281">Replace if damaged.</p>	 <p data-bbox="970 1496 1078 1516">xx1500002039</p>
4	Apply some grease on the o-ring for a better fitting.	
5	Examine the pinion and the splines in the hub for damages.	 <p data-bbox="970 1989 1078 2009">xx1500002082</p>

Continues on next page



4 Repair

4.8.1 Replacing the hub

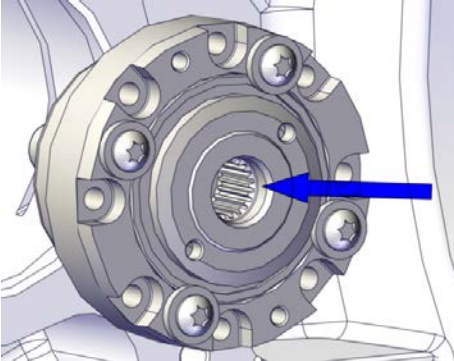
Continued

	Action	Note
6	Make sure that there is enough grease on the splines before fitting. If not, apply 1 gram of grease.	Grease: Castrol Molub. Alloy 777-1 NG  xx1500002346

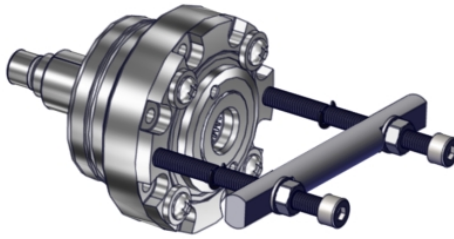

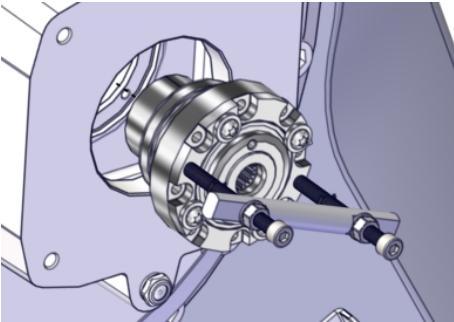
Refitting the hub

	Action	Note
1	Fit the hub tool.	Hub tool: 3HAC071355-001  xx2000001377
2	 CAUTION Whenever parting/mating the hub pinion and gearbox, the gears may be damaged if excessive force is used.	
3	Lift the hub to the gear, and mate the pinon carefully into the gear.	 xx2000001381

Continues on next page

	Action	Note
4	<p>Remove the hub tool and fit the attachment screws for the hub.</p> <p>Apply locking liquid (Loctite 2400 (or equivalent Loctite 243)) on the screws.</p> <p> Note</p> <p>The number of attachment screws differ depending on gearbox.</p>	<p>Attachment screws: M6x30 12.9.</p> <p>Loctite 2400 (or equivalent Loctite 243)</p> <p>Quantity: 6 pcs</p>
5	Secure the hub.	Tightening torque: 14 Nm.

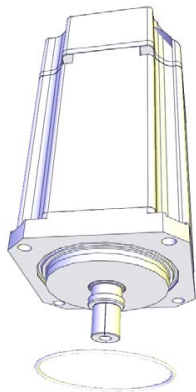
Preparations prior to refitting motor

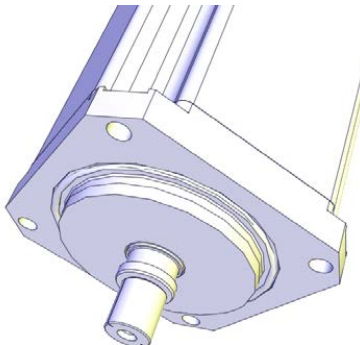

	Action	Note
1	<p> DANGER</p> <p>Make sure that all supplies for electrical power, hydraulic pressure, and air pressure are turned off.</p>	
2	<p>Remove any old paint residues or other contamination from the contact surfaces on both the motor and the mating parts.</p> <p>Wipe clean the contact surfaces and the o-ring groove.</p>	
3	Fit a new o-ring.	 <p>xx1200001019</p>
4	<p>Make sure the o-ring is seated in the groove.</p> <p> Tip</p> <p>Lubricate the o-ring with some grease for a better fitting in the groove.</p>	 <p>xx1200001020</p>

Continues on next page

4 Repair

4.8.1 Replacing the hub

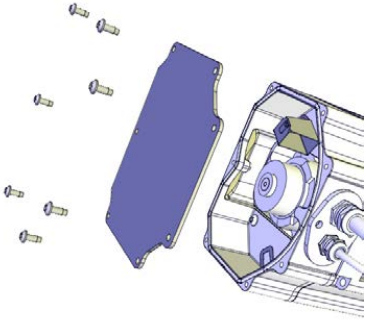
Continued

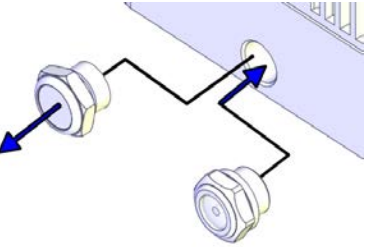
	Action	Note
5	If the motor is a new spare part, remove the cover.	 <p>xx1200001135</p>
6	<p>Protection type Foundry Plus Valid for axis-2, axis-3, axis-4 and axis-6 motors.</p> <p>If the motor is a new spare part, the evacuation hole protection filter must be replaced with a transparent plug/sight glass (enclosed with the spare part delivery). Remove the protection filter and install the transparent plug/sight glass.</p> <p>On the axis-6 motor there are two protection filters that must be replaced with transparent plugs/sight glasses.</p> <div style="display: flex; justify-content: space-around;"> <div data-bbox="485 1041 758 1261">  <p>xx2200002188</p> <p>Transparent plug (Foundry Plus).</p> </div> <div data-bbox="762 1041 1015 1261">  <p>xx1800000101</p> <p>Protection filter (Standard).</p> </div> </div>	<p>Tightening torque, transparent plug: 20 Nm \pm10%</p> <p>Tightening torque, protection filter: 10 Nm \pm10%</p>  <p>xx1600000576</p>

Attaching the removal tool

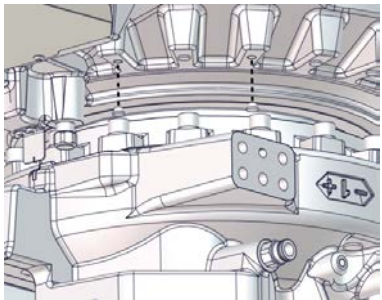
	Action	Note
1	<p>Foundry plus: Remove the plastic plugs.</p>	 <p>xx1700000364</p>

Continues on next page

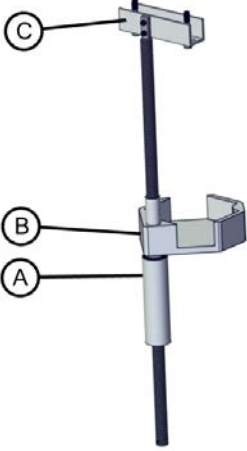
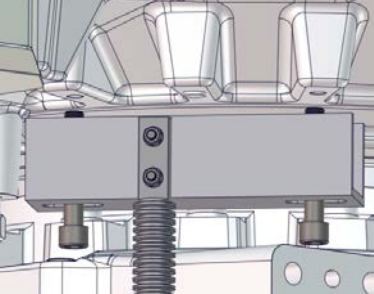
	Action	Note						
2	Lower the revolving handle on the removal tool, to be able to fit the shelf beneath the motor while fastening the tool.	 <p>xx1700000365</p> <table border="1" data-bbox="1062 819 1437 958"> <tr> <td>A</td> <td>Revolving handle</td> </tr> <tr> <td>B</td> <td>Shelf</td> </tr> <tr> <td>C</td> <td>Bracket</td> </tr> </table>	A	Revolving handle	B	Shelf	C	Bracket
A	Revolving handle							
B	Shelf							
C	Bracket							
3	Attach the tools bracket screws to the robot frame.	 <p>xx1700000366</p>						

Securing the axis-1 motor



	Action	Note
1	 CAUTION The weight of the motor is 27 kg All lifting accessories used must be sized accordingly.	
2	Fasten lifting eyes in two of the fastening holes on the motor.	Lifting eye, M12, 3HAC16131-1
3	Use a roundsling to lift the motor.	

Continues on next page

4 Repair

4.8.1 Replacing the hub

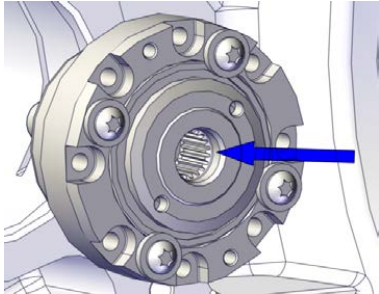
Continued

	Action	Note
4	<p>Connect the 24 VDC power supply to release the brakes.</p> <p>Connect to R2.MP1-connector:</p> <ul style="list-style-type: none"> • + = pin 2 • - = pin 5 <p> Note</p> <p>Put the cables to the brake release tool through the hole in the tool shelf.</p>	
5	Fit guide pins in opposite holes.	<p>Guide pin, M10x150: 3HAC15521-2</p> <p>Always use guide pins in pairs.</p>
6	Apply 3 gram grease on the splines before fitting.	<p>Grease: Castrol Molub. Alloy 777-1 NG</p>  <p>xx1500002346</p>
7	Put the motor on the tool shelf and rotate it into position.	
8	<p> CAUTION</p> <p>Whenever parting/mating motor pinion and hub, the splines may be damaged if excessive force is used.</p>	
9	<p>Raise the revolving handle to assemble motor.</p> <ul style="list-style-type: none"> • Make sure that the motor pinion is properly mated into the hub. • Make sure that the motor pinion does not get damaged. • Make sure that the direction of the cable exit is facing the correct way. 	
10	<p>Secure the motor with its attachment screws and washers.</p> <p>Use a bits extender to reach the screws.</p>	<p>Bits extender: 3HAC12342-1</p> <p>Tightening torque: 50 Nm.</p> <p>Screw dimension : M10x40 quality 12.9 Gleitmo (4 pcs)</p>
11	Perform a leak-down test (if not already done).	See Performing a leak-down test on page 188 .
12	Disconnect the 24 VDC power supply.	

Continues on next page

Removing the removal tool

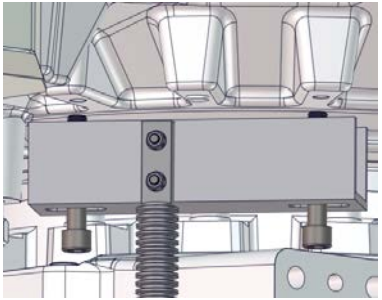
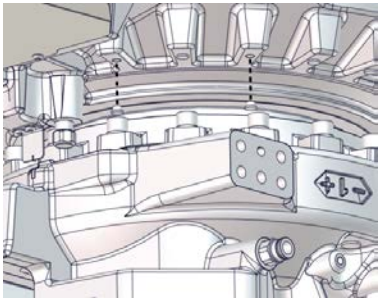
	Action	Note
1	Remove screws holding the tool bracket.	 xx1700000366
2	<i>Foundry plus:</i> Refit the plastic plugs.	 xx1700000364

Connecting the motor cables

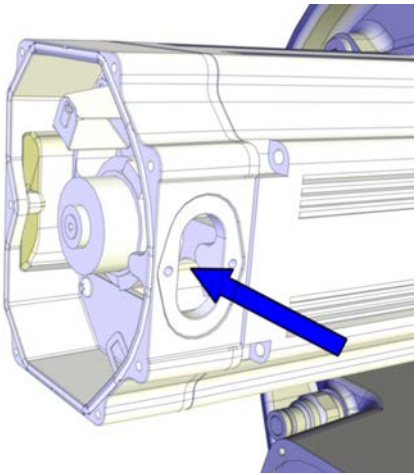

	Action	Note
1	Push the motor cables through the cable gland opening.	 xx1300000738

Continues on next page



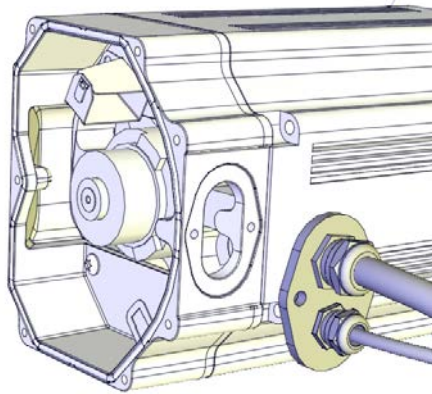
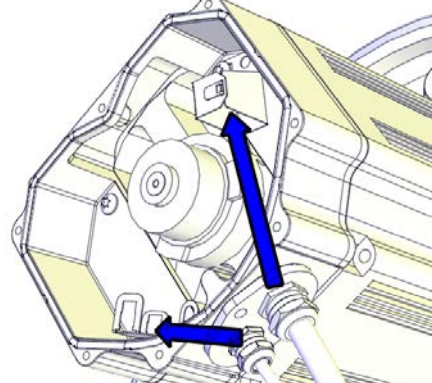

4 Repair

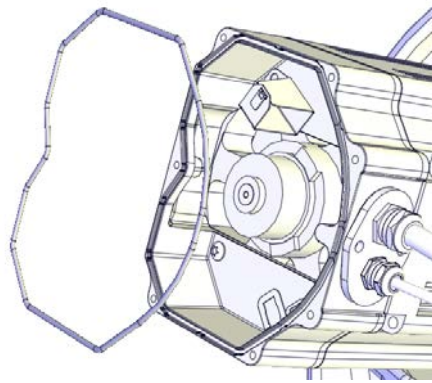
4.8.1 Replacing the hub



Continued

	Action	Note
2	Refit the cable gland cover.  Note Replace the gasket if damaged.	 xx1200001067
3	Connect the motor cables. Connect in accordance with the markings on the connectors.	 xx1200001066
4	Inspect the o-ring.  Note Replace if damaged.	O-ring, axis-1: 3HAC054692-002 O-ring, axis-2: 3HAC054692-002 O-ring, axis-3: 3HAC054692-002 O-ring, axis-4: 3HAC054692-001  xx1200001070
5	Wipe clean o-ring and o-ring groove.	

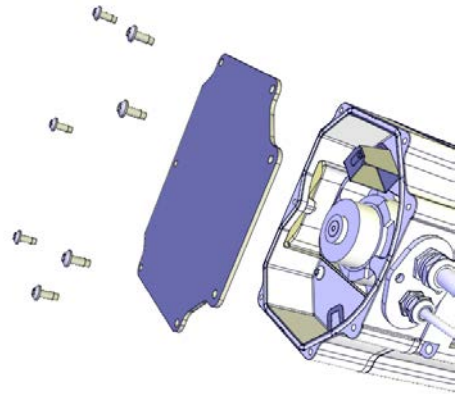
Continues on next page

	Action	Note
6	<p>Refit the o-ring.</p> <p> Tip</p> <p>Lubricate the o-ring with some grease for a better fitting in the groove.</p>	
7	<p> CAUTION</p> <p>When fitting the motor cover, make sure that none of the cables inside will be damaged.</p>	
8	<p>Refit the motor cover with it's attachment screws.</p> <p> Note</p> <p>Do not reuse the self-threading attachment screws. Replace with standard attachment screws or the threads will be damaged.</p> <p> Note</p> <p>Make sure the o-ring is undamaged and properly fitted.</p>	<p>Attachment screws: M5x12 8.8 (7 pcs)</p>  <p>xx1200001135</p>
9	<p>Make sure that the covers are tightly sealed.</p>	

Filling oil into axis-1 gearbox inverted

	Action	Note
1	<p> DANGER</p> <p>Turn off all:</p> <ul style="list-style-type: none"> • electric power supply • hydraulic pressure supply • air pressure supply <p>to the robot, before entering the safeguarded space.</p>	
2	<p> WARNING</p> <p>Handling gearbox oil involves several safety risks, see Gearbox lubricants (oil or grease) on page 33.</p>	

Continues on next page



4 Repair

4.8.1 Replacing the hub

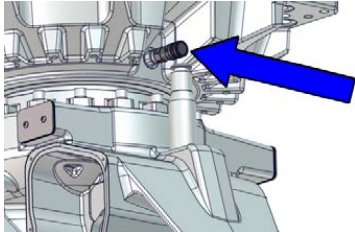
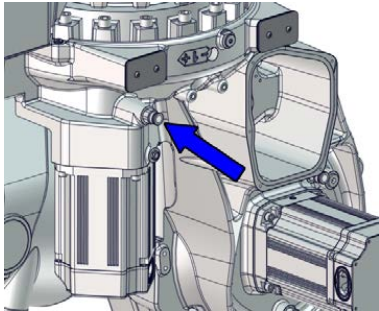
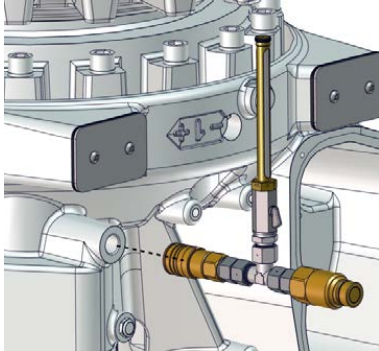
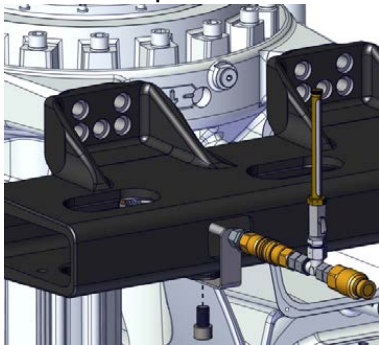
Continued

	Action	Note
3	Install the ventilating valve.	 xx170000349
4	Open the oil plug.	 xx160002042
5	Mount the oil level gauge.	Oil level gauge 3HAC061881-001  xx160002097 <p>If the Fork lift accessory set is assembled, fasten the extender screw in the fork lift pocket.</p>  xx170000314
6	Connect the oil dispenser to the Oil level gauge.	

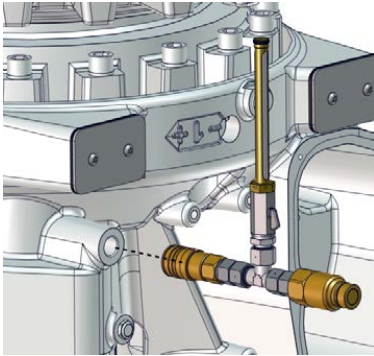
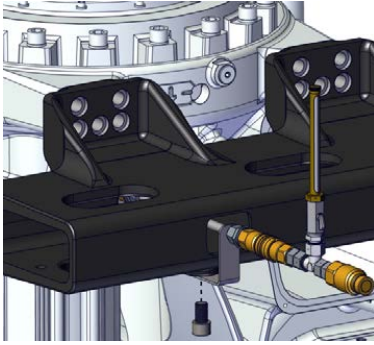
Continues on next page

	Action	Note
7	Refill the gearbox with oil with the oil dispenser.  Note The amount of oil to be filled also depends on the amount previously being drained.	Type of oil and total amount is detailed in <i>Technical reference manual - Lubrication in gearboxes</i> .
8	Inspect the oil level using the Oil level gauge.	Required oil level: Between level measurement marks on tool, but closer to max level.  <small>xx1600002097</small> If the Fork lift accessory set is assembled, fasten the extender screw in the fork lift pocket.  <small>xx1700000314</small>
9	Remove the oil dispenser and the Oil level gauge.	
10	Refit the oil plug.	Tightening torque: 24 Nm
11	 Note After all repair and maintenance work involving oil, always wipe the robot clean from all surplus oil.	
12	 DANGER Make sure all safety requirements are met when performing the first test run. See <i>Test run after installation, maintenance, or repair on page 97</i> .	

Continues on next page

4 Repair

4.8.1 Replacing the hub

Continued

Concluding procedure

Use this procedure for the concluding refitting.

	Action	Note
1	Re-calibrate the robot.	Axis Calibration is described in Calibrating with Axis Calibration method on page 694 . General calibration information is included in section Calibration on page 683 .
2	 DANGER Make sure all safety requirements are met when performing the first test run. See Test run after installation, maintenance, or repair on page 97 .	

4.8.2 Replacing the axis-1 gearbox

Location of the axis-1 gearbox

The axis-1 gearbox is located as shown in the figure.

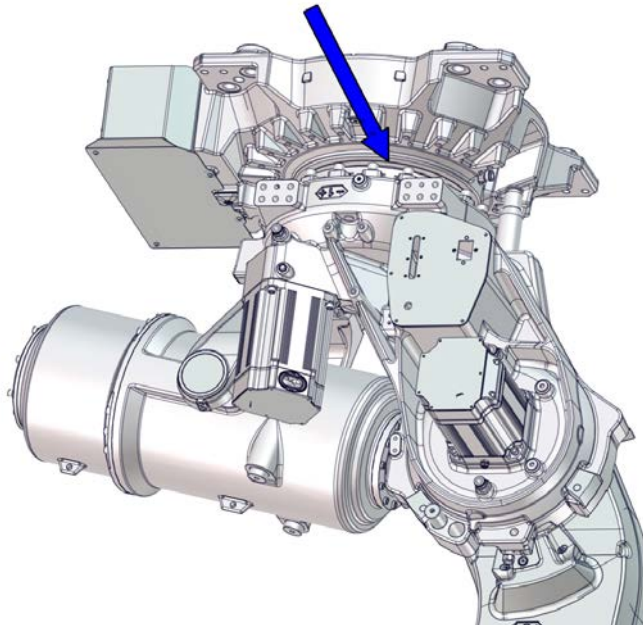

xx170000095



Note

The robot must be taken down and secured floor standing to perform this replacement procedure.

How to do this is described in the removal procedure in this section.



DANGER

Always lock the position of the lower arm, using the yellow sleeve and transportation lock screw, before attempting to lift the robot.

Summary of the replacement procedure

This is a brief summary of the replacement procedure, containing the major actions to be performed.

- 1 Lift down the robot to floor standing.
- 2 Drain the axis-1 gearbox.
- 3 Remove the cabling from the base.
- 4 Remove the axis-1 motor.
- 5 Remove the complete arm system (including frame and balancing device) as a package.
- 6 Replace the axis-1 gearbox.
- 7 Refit in reverse order.

Continues on next page

4 Repair

4.8.2 Replacing the axis-1 gearbox

Continued

Spare parts

Spare parts	Article number	Note
Axis-1 gearbox	See <i>Product manual, spare parts - IRB 6700/IRB 6700Inv.</i>	

Required tools and equipment

Equipment, etc.	Article number	Note
Fork lift accessory set	3HAC058825-001	Contains fork lift pockets and all required hardware for installation. User instructions are enclosed with the tool, see Directions for use - Fork lift accessory 3HAC058825-001. In order to rotate the robot, either use the turning tool or a fork lift truck with a rotator attachment.
Turning tool	3HAC073537-001	Lift and rotation of inverted robot. Requires fork lift accessory set 3HAC058825-001. User instructions are enclosed with the tool.
Oil collecting vessel	-	The capacity of the vessel must be sufficient to take the complete amount of oil.
Oil dispenser	-	One example of oil dispenser can be found in section Type of lubrication in gearboxes on page 147 .
Removal tool motor M12	3HAC14631-1	Used to push out the motor, if necessary. Always use removal tools in pairs.
Bits extender	3HAC12342-1	300 mm, bits 1/2"
Lifting eye, M12	3HAC16131-1	
Lifting eye, M12	3HAC16131-1	
Fender washer	-	Outer diameter: minimum 26 mm, maximum 30 mm, hole diameter: 13 mm, thickness: 3 mm.
Lifting shackle, 2 pcs	-	SA-10-8-NA1
Roundsling, 2 m	-	Lifting capacity: 2,000 kg.
Lifting accessory (chain)	3HAC15556-1	Lifting instruction 3HAC15880-2 enclosed.
Lifting eye, M16	3HAC14457-4	
Lifting eye, M16	3HAC14457-4	
Lifting accessory, motor	3HAC14459-1	
Rotation tool	3HAB7887-1	Used to rotate the motor pinion.
Aligning tool	3HAC046645-003	Used for aligning the gearbox against the frame, so that the play in the motor does not need to be adjusted.
24 VDC power supply	-	Used to release the motor brakes.

Continues on next page

4.8.2 Replacing the axis-1 gearbox
Continued

Equipment, etc.	Article number	Note
Guide pin, M10x150	3HAC15521-2	Always use guide pins in pairs.
Guide pin, M10x150	3HAC15521-2	Always use guide pins in pairs.
Guide pin, M16x120	3HAC062397-001	Always use guide pins in pairs.
Guide pin, M16x120	3HAC062397-001	Always use guide pins in pairs.
Guide pin, M20x180	3HAC048814-002	Always use guide pins in pairs.
Support legs	3HAC15535-1	
Bit holder	3HAC029090-001	
Leak-down tester	-	
Calibration tool box, Axis Calibration	3HAC055412-001	Delivered as a set of calibration tools.
Standard toolkit	-	Content is defined in section Standard toolkit on page 724 .

Consumables

Equipment, etc	Article number	Note
Flange sealant	-	Loctite 574
Grease	3HAC042536-001	Shell Gadus S2 Used to lubricate o-rings.
Grease	-	Castrol Molub. Alloy 777-1 NG Used on hub splines to prevent from fretting corrosion.
Locking liquid	-	Loctite 2400 (or equivalent Loctite 243)
O-ring	3HAB3772-160	414.3x5.7. Located between the gearbox and the frame.
O-ring	3HAB3772-150	183.74x3.53. Located between the gearbox and the base.
O-ring	3HAC054692-002	D=169.5x3 Used on motor cover.
O-ring	3HAB3772-107	D=102x3 Used on motor flange.
Sealing ring	3HAC047474-001	Located in the frame, on top of the protection tube.
O-ring	3HAB3772-57	Located on the sealing ring.
Radial sealing with dust lip	3HAB3701-51	Located in the frame, underneath the sealing ring.
Cable straps	-	

Required documents

Document name	Document number	Note
<i>Technical reference manual - Lubrication in gearboxes</i>	3HAC042927-001	

Continues on next page

4 Repair

4.8.2 Replacing the axis-1 gearbox

Continued

Document name	Document number	Note
Directions for use - Fork lift accessory 3HAC058825-001	3HAC060303-001	
Directions for use - Lifting and rotating accessory for IRB 6700Inv/IRB6700I	3HAC073537-003	

Deciding calibration routine

Decide which calibration routine to be used, based on the information in the table. Depending on which routine is chosen, action might be required prior to beginning the repair work of the robot, see the table.

	Action	Note
1	Decide which calibration routine to use for calibrating the robot. <ul style="list-style-type: none"> Reference calibration. External cable packages (DressPack) and tools can stay fitted on the robot. Fine calibration. All external cable packages (DressPack) and tools must be removed from the robot. 	
	If the robot is to be calibrated with reference calibration: Find previous reference values for the axis or create new reference values. These values are to be used after the repair procedure is completed, for calibration of the robot. If no previous reference values exist, and no new reference values can be created, then reference calibration is not possible.	Follow the instructions given in the reference calibration routine on the FlexPendant to create reference values. Creating new values requires possibility to move the robot. Read more about reference calibration for Axis Calibration in Reference calibration routine on page 695 .
	If the robot is to be calibrated with fine calibration: Remove all external cable packages (DressPack) and tools from the robot.	

Removing the axis-1 gearbox

These procedures describe how to remove the gearbox.

Securing the lower arm

Use this procedure to secure the lower arm.

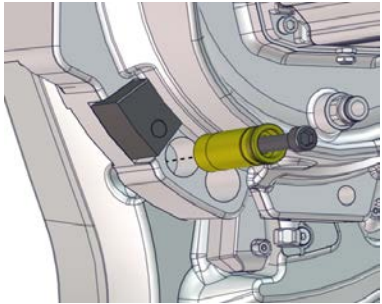
	Action	Note
1	Jog axis 2 to -35°.	
2	Remove the transportation lock screw and the yellow sleeve from the parking position.	 xx1700000270

Continues on next page

4.8.2 Replacing the axis-1 gearbox
Continued

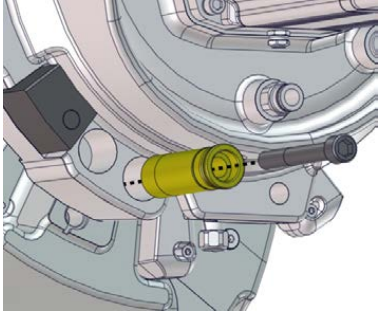
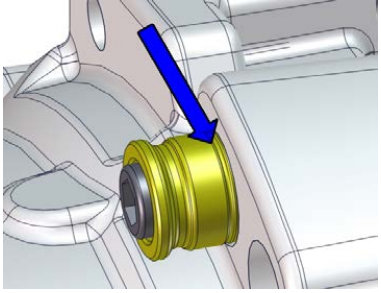
	Action	Note
3	<p>Insert the yellow sleeve and the transportation lock screw in the hole at the locking position. Insert the sleeve all the way so that the marking in the sleeve is aligned with the casting, see figure.</p> <p>Tighten the screw.</p> <p> DANGER</p> <p>Always use the transportation lock screw and sleeve to lock the lower arm at transportation, turning and floor standing.</p>	<p>Tightening torque: 70 Nm ±15 Nm.</p>  <p>xx1700000269</p>  <p>xx1600002114</p>

Lifting down the robot from inverted position

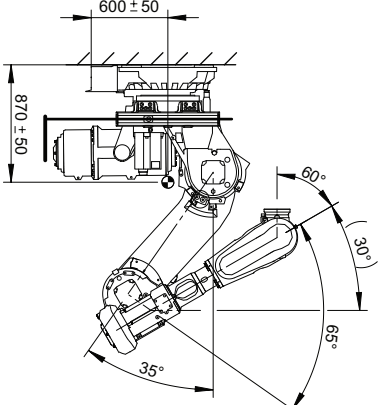

	Action	Note
1	<p> DANGER</p> <p>The robot must always be secured to the foundation if any kind of repair or maintenance work is to be performed.</p> <p>For some repair work support legs are required.</p>	<p>Suitable screws, lightly lubricated: M24x100 (min. 4 pcs)</p> <p>For hole configuration, see Hole configuration, base on page 66.</p>
2	<p>Verify that the lower arm is secured with the transportation lock screw.</p>	
3	<p>Remove any payload and tools from the robot.</p>	<p>DressPack can stay fitted.</p>
4	<p>Jog the robot into position:</p> <ul style="list-style-type: none"> • Axis 1: 0° • Axis 2: already in position and locked with the transportation lock screw, do not jog! • Axis 3: +65° • Axis 4: 0° • Axis 5: +60° • Axis 6: no significance 	 <p>xx1700000555</p>

Continues on next page



4 Repair

4.8.2 Replacing the axis-1 gearbox

Continued

	Action	Note
5	 DANGER Turn off all: <ul style="list-style-type: none">• electric power supply• hydraulic pressure supply• air pressure supply to the robot, before entering the safeguarded space.	
6	Disconnect the robot cables at the base.	
7	 CAUTION The weight of the IRB 6700Inv / IRB 6700I robot is 1,750 kg All lifting accessories used must be sized accordingly.	
8	Install the fork lift pockets to the robot.  DANGER Handling the tool incorrectly will cause serious injury. Read and follow enclosed user instructions for the tool.	See user instructions enclosed with the fork lift accessory set. Fork lift accessory set: 3HAC058825-001.

Continues on next page

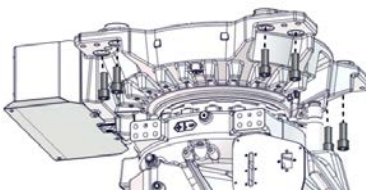
	Action	Note
9	<p>Choose one of the following lifting methods:</p> <ul style="list-style-type: none"> Lifting and turning with the fork lift (rotator attachment required): <ol style="list-style-type: none"> 1 Insert the forks of the fork lift truck into the fork lift pockets, as far as possible. 2 Raise the forks of the fork lift truck to make sure that the weight of the robot rests on the forks. <p> Tip</p> <p>Two M16 screws can be fitted to the fork lift pockets, to press the forks against the pockets and make the lift more stable.</p> Lifting and turning with the turning tool and overhead crane: <ol style="list-style-type: none"> 1 Install and use the turning tool according to enclosed user instructions. <p> DANGER</p> <p>Handling the tool incorrectly will cause serious injury.</p> <p>Read and follow enclosed user instructions for the tool.</p> 	
10	Remove the bolts that secure the robot to the foundation.	<p>Quantity: 8 pcs.</p>  <p>xx1600002098</p>
11	Rotate the robot to floor standing position.	Follow the user instructions enclosed with the turning tool.
12	<p>Lower and secure the robot to the floor. (Or to support legs, if replacing the axis-1 gearbox.)</p> <p>The lifting accessories can be kept installed if they are not in the way for the upcoming service procedure.</p>	Attachment screws: M24x100 (min. 4 pcs required to perform service)

Continues on next page





4 Repair

4.8.2 Replacing the axis-1 gearbox

Continued

Preparations before removing the axis-1 gearbox

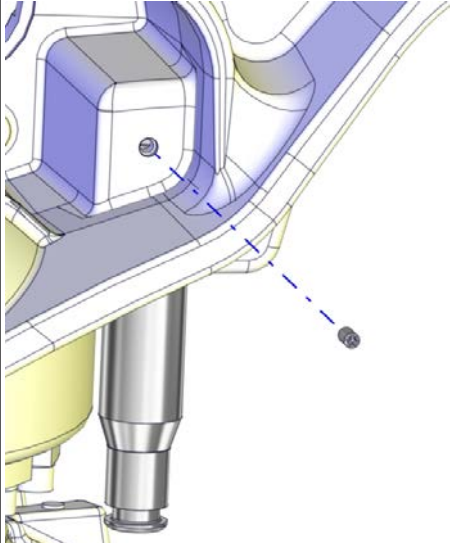
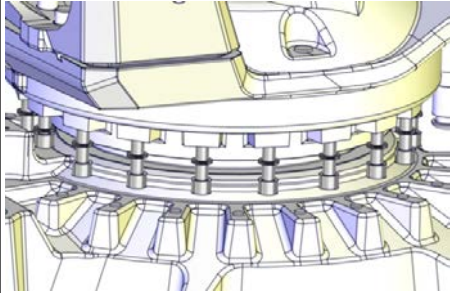



Use this procedure to do the necessary preparations, before removing the gearbox.

	Action	Note
1	 DANGER Turn off all: <ul style="list-style-type: none"> • electric power supply • hydraulic pressure supply • air pressure supply to the robot, before entering the safeguarded space.	
2	Remove tools and other equipment fitted on the turning disc. DressPack can stay fitted for the time being.	This is done to achieve the best stability of the complete arm system, when it is resting by itself, after it has been removed.
3	Hold the mechanical stop pin in a firm grip, and remove it by unscrewing the attachment screw.  CAUTION The mechanical stop weighs 5 kg.	 <small>xx1400002179</small>
4	Begin draining the axis-1 gearbox.	See Draining the axis-1 gearbox floor-standing on page 152 .
5	Loosen 14 of the 18 attachment screws as far as it is possible at this point. The four screws that are left in place, diagonally located to each other, work as an anvil for the axis 1 rotation when unscrewing the hub later on.	 <small>xx1400002169</small>  Note It will not be possible to remove the screws completely at this point.

Continues on next page

Attaching the lifting accessories to the arm system

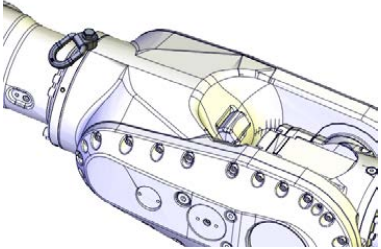
This procedure contains two alternative methods for lifting the arm system, either by using the turning tool or by using lifting chains.

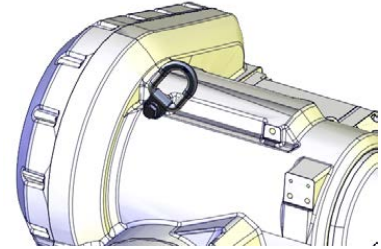
	Action	Note
1	 <p>DANGER</p> <p>Make sure that all supplies for electrical power, hydraulic pressure, and air pressure are turned off.</p>	
2	 <p>CAUTION</p> <p>The complete arm system weighs . 1,300 kg (IRB 6700Inv -300/2.60, -245/2.90) 1,320 kg (IRB 6700I -270/2.60 LID, -210/2.90 LID) All lifting accessories used must be sized accordingly!</p>	
3	Fit a lifting eye to the wrist.	<p>Lifting eye, M12: 3HAC16131-1</p>  <p>xx1200001133</p>
4	<p>Fit a lifting eye to the arm house, with a fender washer underneath.</p>  <p>xx1400002196</p>	<p>Lifting eye, M12: 3HAC16131-1 Fender washer. Outer diameter: minimum 26 mm, maximum 30 mm, hole diameter: 13 mm, thickness: 3 mm.</p>  <p>xx1200001134</p>
5	<p>Choose which lifting accessory to use:</p> <ul style="list-style-type: none"> • Attach the lifting chains on page 574 • Attach the Turning tool on page 576. Convenient if the tool is already partly mounted on the robot after rotation from inverted position to floor-standing. 	

Continues on next page

4 Repair

4.8.2 Replacing the axis-1 gearbox



Continued

Attach the lifting chains

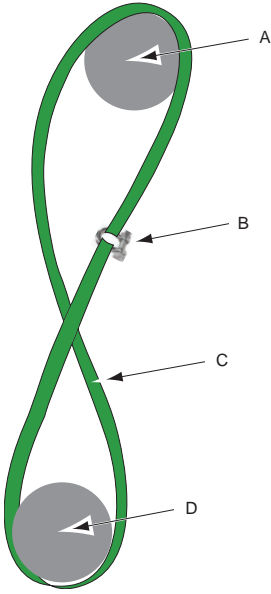
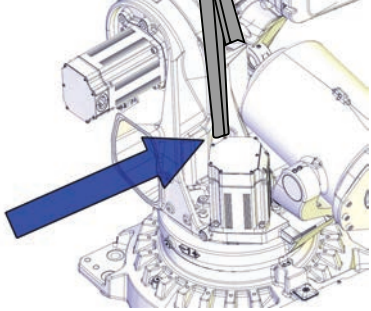
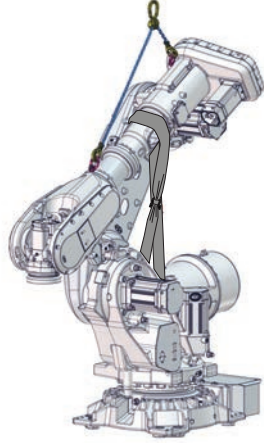
Use this procedure to attach the Lifting accessory (chain).

	Action	Note
1	<p>Run a roundsling through the hole in the frame, continue up and over the upper arm.</p> <p> Tip</p> <p>When attaching the roundsling, make sure to cross it over, creating a figure 8 of the roundsling. This will prevent the roundsling from gliding.</p>  <p>xx140000728</p> <p>A Upper arm B Shackle C Roundsling D Hole in frame</p>	<p>Roundsling, 2 m: Lifting capacity: 2,000 kg.</p>  <p>xx1400002107</p>  <p>xx1700000317</p>

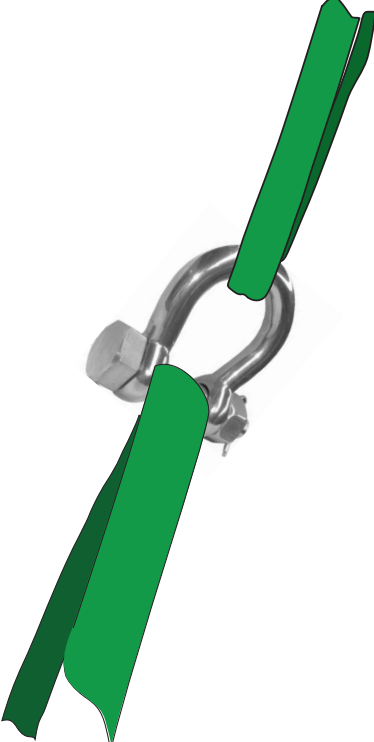
Continues on next page

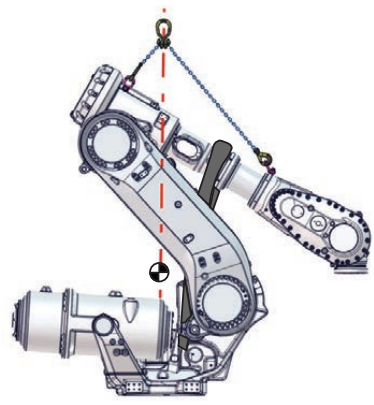

	Action	Note
2	<p>Connect the roundsling with a shackle.</p>	<p>Lifting shackle, 2 pcs SA-10-8-NA1</p>  <p>xx1400000729</p>
3	<p>Use caution and jog axis-3 slowly to stretch the roundsling.</p> <p> Note</p> <p>Make sure the roundsling is stretched, so it can carry the weight of the frame. The position of axis 3 will be approximately -45°.</p>	
4	<p>Attach the Lifting accessory (chain) to an overhead crane (or similar) and then to the lifting eye in the arm house and to the lifting eye in the wrist.</p> <p>Adjust the lengths of the chains so that the lifting hook is located in line with the center of gravity when the robot arm system is lifted, as shown in the figure.</p>	<p>Lifting accessory (chain): 3HAC15556-1</p>  <p>xx1700000313</p>

Continues on next page

4 Repair

4.8.2 Replacing the axis-1 gearbox

Continued

	Action	Note
5	 <p>WARNING</p> <p>The angle between the two chains may not exceed 90°.</p>	 <p>xx1700000319</p>

Attach the Turning tool

Use this procedure to attach the Turning tool for lift of the arm system.

	Action	Note
1	<p>Secure the turning tool chain block to the lifting eye in the wrist. Shorten the chain to make the lift horizontal.</p>	<p>Turning tool: 3HAC073537-001</p>  <p>xx1700000695</p>
2	<p>Fit a roundslings between the overhead crane hook and the lifting eye in the arm house.</p>	

Disconnecting the axis-1 motor cables

	Action	Note
1	 <p>DANGER</p> <p>Make sure that all supplies for electrical power, hydraulic pressure, and air pressure are turned off.</p>	

Continues on next page

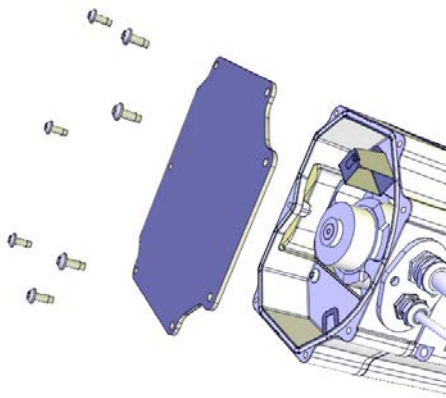
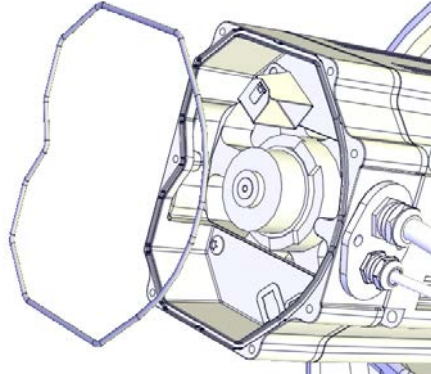
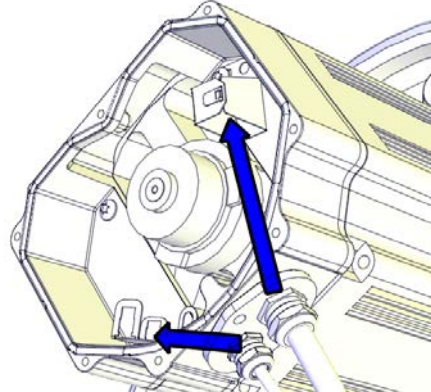
	Action	Note
2	Unscrew the attachment screws and washers and remove the motor cover.	 <p>xx1200001135</p>
3	Make sure the o-ring is present.	 <p>xx1200001070</p>
4	Disconnect the motor cables.	 <p>xx1200001066</p>

Continues on next page



4 Repair

4.8.2 Replacing the axis-1 gearbox

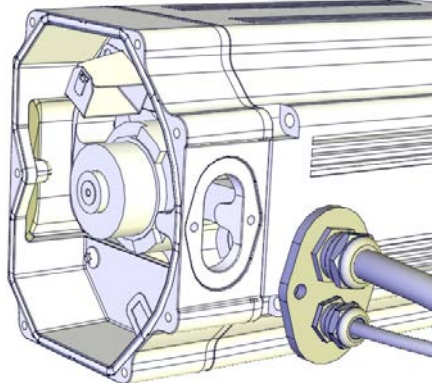

Continued

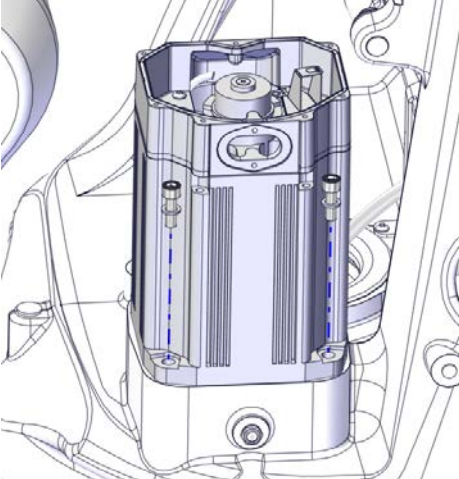
	Action	Note
5	<p>Remove the cable gland cover. Make sure the gasket is not damaged.</p> <p> Tip</p> <p>Make a note in which direction the cable gland hole is facing, if the motor will be removed too. The motor shall be refitted in the same position.</p>	 <p>xx1200001067</p>
6	Use caution and pull out the motor cables.	

Removing the axis-1 motor

	Action	Note
1	<p> DANGER</p> <p>Make sure that all supplies for electrical power, hydraulic pressure, and air pressure are turned off.</p>	
2	<p>Unscrew the attachment screws and washers. Use a bits extender to reach the screws.</p>	<p>Bits extender: 3HAC12342-1</p>  <p>xx1500002083</p>
3	Fit guide pins in opposite holes.	<p>Guide pin, M10x150: 3HAC15521-2 Always use guide pins in pairs.</p>
4	<p> CAUTION</p> <p>Whenever parting/mating motor pinion and hub, the splines may be damaged if excessive force is used.</p>	

Continues on next page

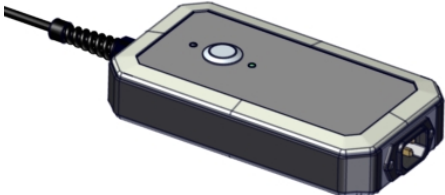
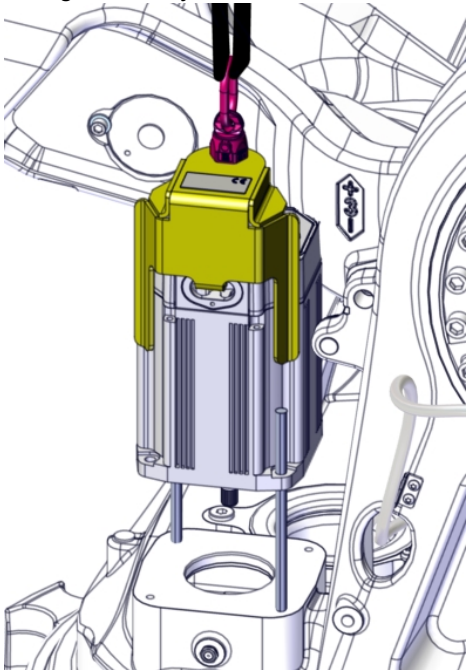
	Action	Note
5	If needed, use removal tools to help loosen the motor.	Removal tool motor M12: 3HAC14631-1 Used to push out the motor, if necessary. Always use removal tools in pairs.
6	 CAUTION The weight of the motor is 27 kg All lifting accessories used must be sized accordingly.	
7	Attach the lifting accessories.	Lifting accessory (chain): 3HAC15556-1 Lifting accessory, motor: 3HAC14459-1.
8	Release the brakes of the axis-1 motor with the brake release tool. <ol style="list-style-type: none"> 1 Turn off the brake release tool. 2 Connect the tool to the R2.MP1 connector. 3 Release the brakes by turning on the brake release tool and pressing the brake release button on the tool.  DANGER Handling the tool incorrectly will cause serious injury. Read and follow enclosed user instructions for the tool.	Brake release tool: 3HAC081310-001 User instructions are enclosed with the tool.  <small>xx210000666</small>
9	Use caution and lift the motor straight up to get the pinion parted from the gear.	Lifting accessory (chain): 3HAC15556-1 Lifting accessory, motor: 3HAC14459-1.  <small>xx1500002084</small>

Continues on next page





4 Repair

4.8.2 Replacing the axis-1 gearbox

Continued

	Action	Note
10	Disconnect the brake release tool / 24 VDC power supply.	

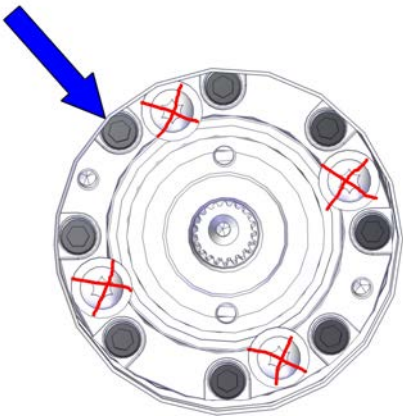
Removing the hub

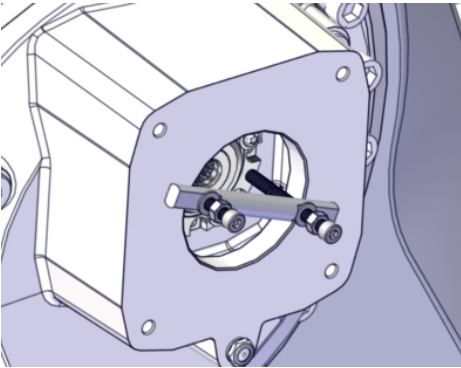
	Action	Note
1	 DANGER Make sure that all supplies for electrical power, hydraulic pressure, and air pressure are turned off.	
2	Unscrew the M6x30 hex socket head cap screws that secure the hub.  Note Do not remove the M6x16 torx pan head screws.	 xx1500002038
3	 CAUTION Whenever parting/mating the hub pinion and gearbox, the gears may be damaged if excessive force is used.	
4	Fit the two threaded rods of the hub tool into the attachment holes in the hub.	Hub tool: 3HAC071355-001  xx2000001379

Continues on next page

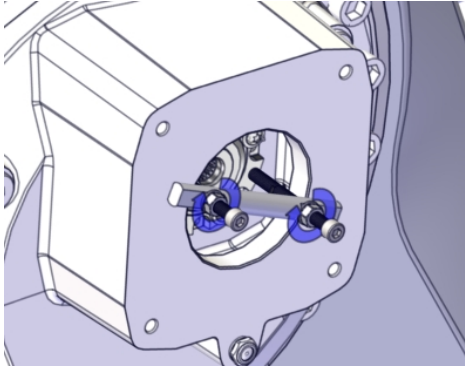
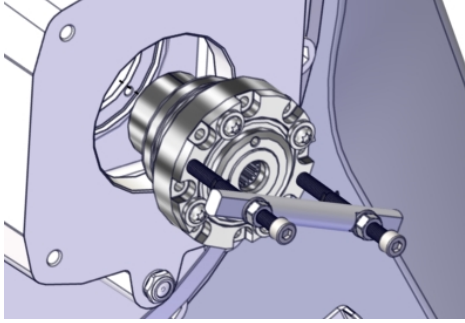
	Action	Note
5	Alternately thread the nuts clockwise on the two rods to pull out the hub from the gear.	 <p>xx2000001380</p>
6	Lift out the hub carefully.	 <p>xx2000001381</p>
7	Cover the hole to avoid getting debris into the gearbox during remaining service work.	

Preparations before removing the cable harness in the base

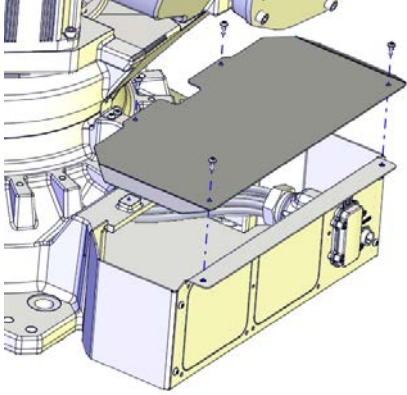
	Action	Note
1	 DANGER Make sure that all supplies for electrical power, hydraulic pressure, and air pressure are turned off.	
2	Remove the base cover.	 <p>xx1300000561</p>

Continues on next page

4 Repair

4.8.2 Replacing the axis-1 gearbox

Continued

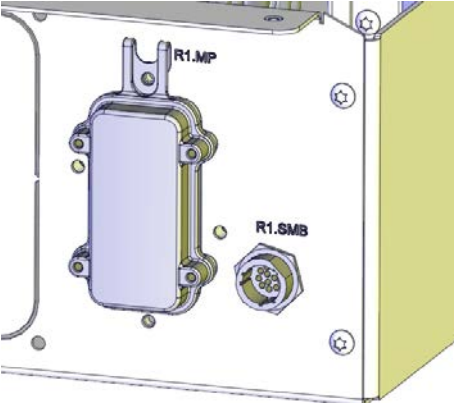
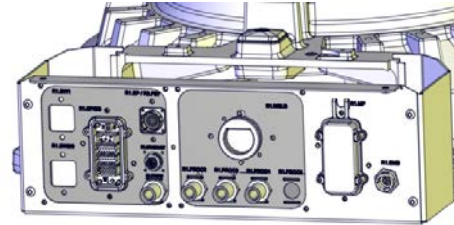
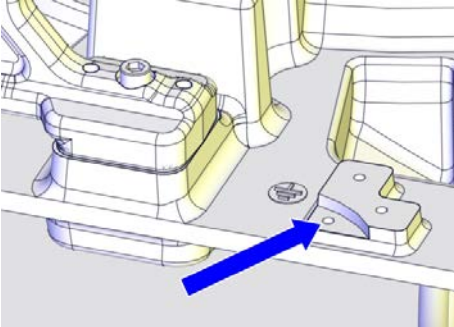
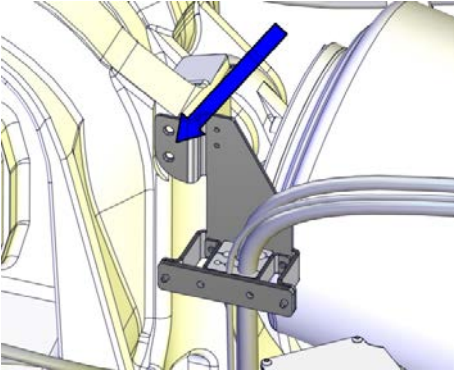
	Action	Note
3	Disconnect connectors: <ul style="list-style-type: none"> • R1.MP • R1.SMB 	 <p>xx1300000591</p>
4	If used, disconnect the DressPack hoses in the base.	 <p>xx1400000366</p>
5	Disconnect the earth cable.	Screw dimension : M6x16 Washer dimension : 6.4x17x3  <p>xx1400000354</p>
6	If used, remove the attachment screws that secure the bracket. This is done to facilitate removal of the DressPack hoses.	 <p>xx1400000078</p>

Continues on next page

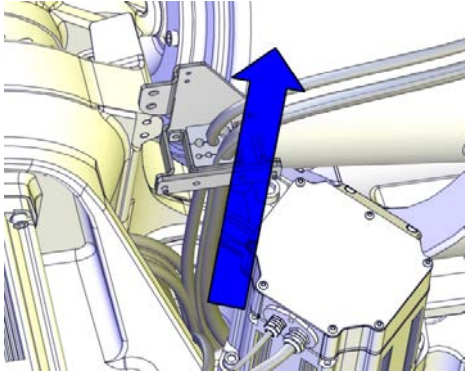
	Action	Note
7	<p>If used, use caution and pull out the DressPack hoses through the protection tube in the base.</p> <p> Note</p> <p>There is no need to pull out the DressPack cables at this point!</p>	 <p>xx140000088</p>

Removing the cable harness in the base

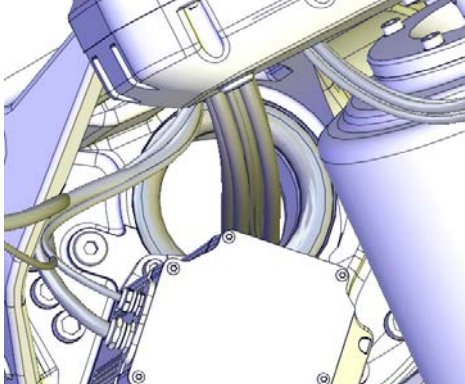
	Action	Note
1	<p>If equipped with DressPack, pull out the DressPack cables through the protection tube and place them carefully over the balancing device.</p>	
2	<p>Pull out the robot cable harness through the protection tube.</p>	 <p>xx1300000732</p>
3	<p>Place the cable harness over the balancing device.</p>	

Lifting away the complete arm system

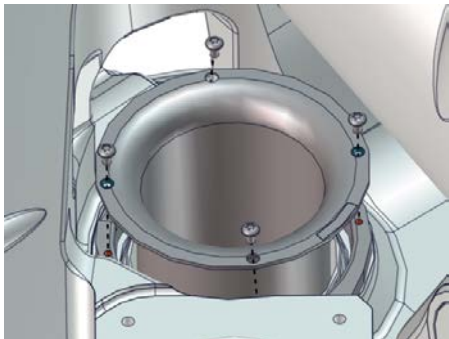

	Action	Note
1	<p>Remove the cable guide in the frame by removing the four attachment screws and pulling the guide upwards.</p>	 <p>xx1700001256</p>

Continues on next page

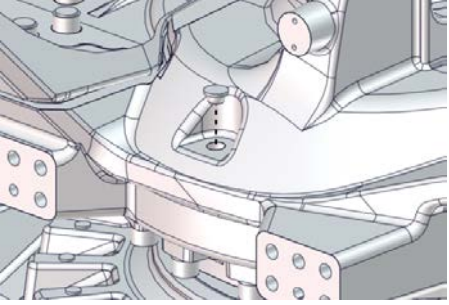
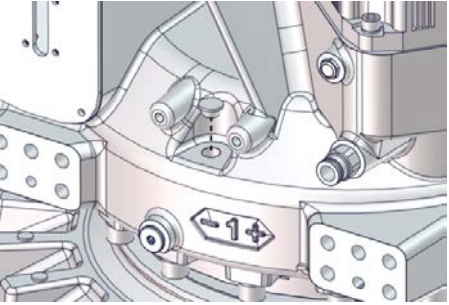
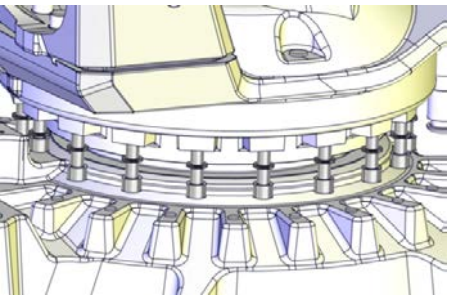

4 Repair

4.8.2 Replacing the axis-1 gearbox



Continued

	Action	Note
2	Check that the axis-1 gearbox is drained and then remove the draining equipment.	
3	Raise the overhead crane to stretch all lifting accessories.	
4	<p>Remove the two protection plugs or M16 screws on the left and right hand side of the frame and install guide pins in the holes.</p> <p> Tip</p> <p>Lubricate the guide pins with some grease to make the frame slide better.</p>	 <p>xx170000320</p>  <p>xx170000321</p> <p>Guide pin, M16x120: 3HAC062397-001 Always use guide pins in pairs.</p>
5	Unscrew the remaining attachment screws as far as it is possible at this point.	 <p>xx1400002169</p> <p> Note</p> <p>It will not be possible to remove the screws completely at this point.</p>
6	<p> CAUTION</p> <p>The complete arm system weighs: . 1,300 kg (IRB 6700Inv -300/2.60, -245/2.90) 1,320 kg (IRB 6700I -270/2.60 LID, -210/2.90 LID)</p> <p>All lifting accessories used must be sized accordingly.</p>	

Continues on next page

	Action	Note
7	<p>Lift away the complete arm system.</p> <p> CAUTION</p> <p>When the arm system has left the guide pins it can move. Use caution in order to avoid injury or damage!</p> <p> Note</p> <p>There will be some oil spill!</p>	
8	<p>Put down the arm system on the floor.</p>	
9	<p> DANGER</p> <p>When the complete arm system is removed and resting by itself on the floor, make sure it is resting completely stable before removing the lifting accessories. Do not change the position of the axes from the position described earlier.</p>	

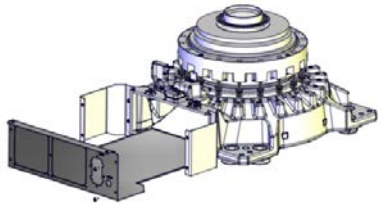
Removing the gearbox

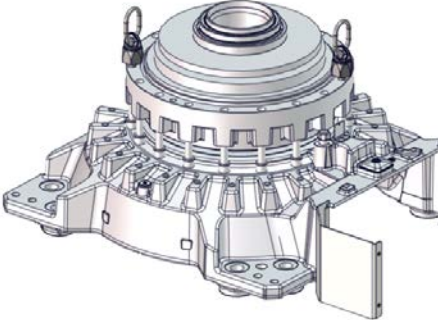
	Action	Note
1	<p>Remove the back plate.</p>	 <p>xx1400002171</p>
2	<p>Fit two lifting eyes in opposite holes in the gearbox.</p> <p> CAUTION</p> <p>Leave a couple of millimeters of space between the lug and the surface of the gearbox. This is done in order not to damage the surface of the gearbox which is a sealing surface.</p>	<p>Lifting eye, M16: 3HAC14457-4</p>  <p>xx1700000323</p>

Continues on next page



4 Repair

4.8.2 Replacing the axis-1 gearbox

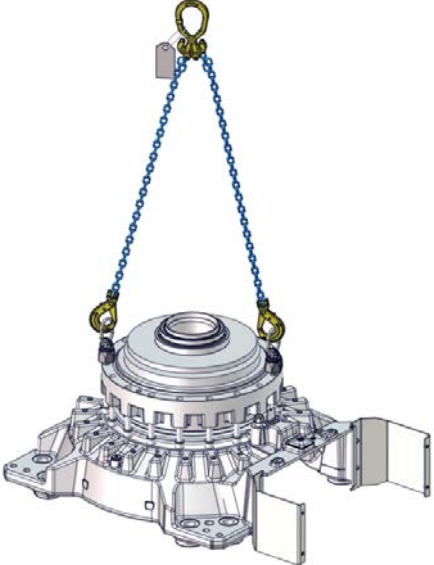
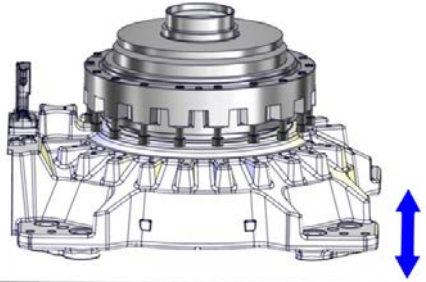
Continued

	Action	Note
3	<p> CAUTION</p> <p>The weight of the gearbox and base together is 305 kg</p> <p>All lifting accessories used must be sized accordingly.</p>	
4	Attach the lifting accessory.	<p>Lifting accessory (chain): 3HAC15556-1</p>  <p>xx170000324</p>
5	Unscrew the attachment screws that hold the base to the foundation and lift base and gearbox up high enough to be able to fit the four support legs.	 <p>xx1400002180</p>

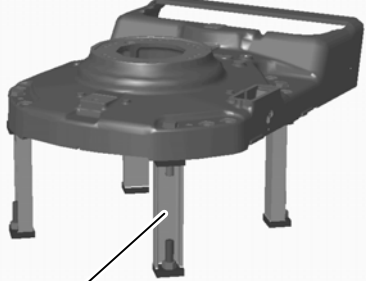
Continues on next page

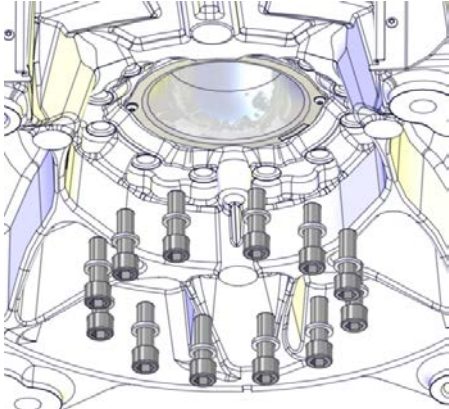
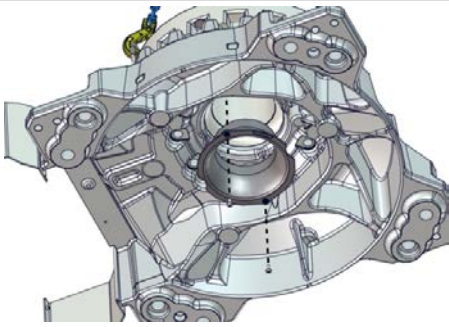

Action	Note
6 Secure the support legs to the foundation using the same holes as to secure the base.	
7 Lower the base and gearbox to the support legs and secure.	 <p>xx100000364</p> <p>A Support legs: 3HAC15535-1.</p>
<p>8 With base and gearbox safely resting on the support legs, unscrew the attachment screws that secure the gearbox to the base, from underneath the base.</p> <p> Tip</p> <p>This procedure is best performed by two persons working together:</p> <ul style="list-style-type: none"> • one underneath the robot base making sure that the bit is being fitted into the screw head holes, all the way until they reach the bottom • one using the torque wrench, tightening the screws from beside the base. 	 <p>xx1400002172</p>
9 Remove the protection tube from the base by removing the two attachment screws and pulling the tube downwards.	 <p>xx1700000561</p>

Continues on next page

4 Repair

4.8.2 Replacing the axis-1 gearbox

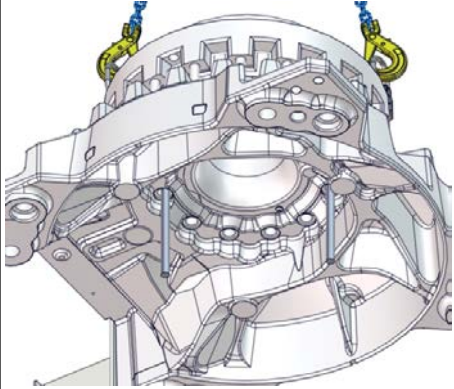
Continued

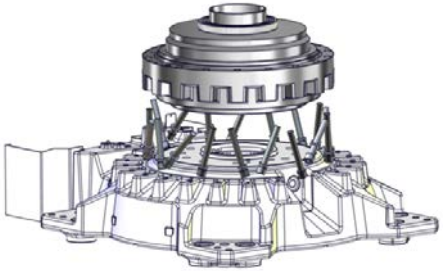
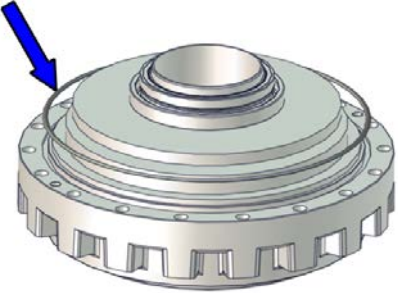
Action	Note
<p>10 Fit two guide pins in opposite holes.</p> <p> Tip</p> <p>Lubricate the guide pins with some grease to make the gearbox slide better.</p>	<p>Guide pin, M20x180: 3HAC048814-002 Always use guide pins in pairs.</p>  <p>xx170000337</p>
<p>11  CAUTION</p> <p>The weight of the gearbox is 140 kg All lifting accessories used must be sized accordingly.</p>	
<p>12 Lift away the gearbox.</p>	 <p>xx170000566</p>
<p>13 Remove the old o-ring to use it as aid in holding the screws during fitting of the new gearbox. A new o-ring must be installed to the new gearbox.</p>	 <p>xx1700001378</p>

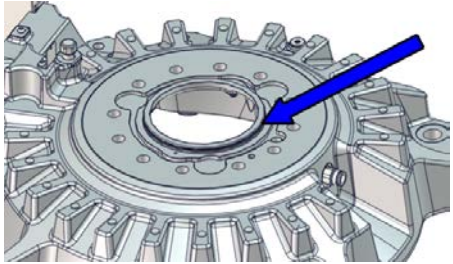

Continues on next page

Action	Note
<p>14 Make sure that the o-ring between base and gearbox is not lost.</p>	 <p>xx1700001376</p>

Refitting the axis-1 gearbox

These procedures describe how to refit the axis-1 gearbox.

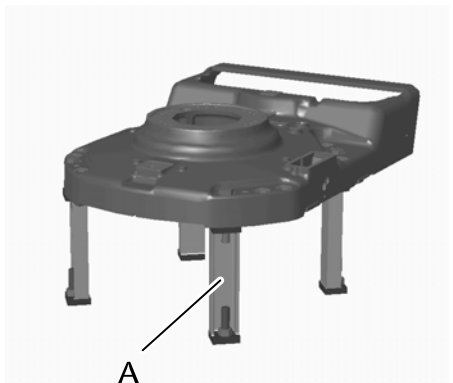
Preparations before refitting the axis-1 gearbox

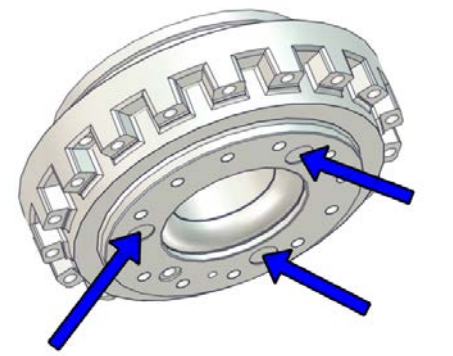

Action	Note
<p>1 If not already done, fit and secure the four support legs to the foundation. Then lift up and secure the base on top of the legs.</p>	 <p>xx1000000364</p> <p>A Support legs: 3HAC15535-1.</p>
<p>2 Remove the three VK covers from the new gearbox by driving a screwdriver (or similar) through the VK cover, as close as possible to the center of the cover. The covers must not be installed in the gearbox for IRB 6700Inv / IRB 6700I.</p> <p> WARNING</p> <p>Be careful not to damage the gearbox during removal of the covers. Remove any residuals.</p>	 <p>xx1700001369</p>

Continues on next page

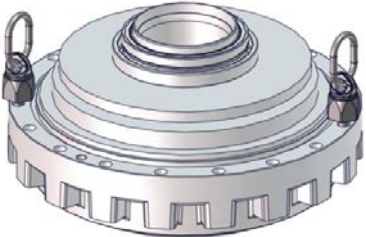

4 Repair

4.8.2 Replacing the axis-1 gearbox

Continued

	Action	Note
3	<p>Fit two lifting eyes in opposite holes in the gearbox.</p> <p> CAUTION</p> <p>Leave a couple of millimeters of space between the lug and the surface of the gearbox. This is done in order not to damage the surface of the gearbox which is a sealing surface.</p>	<p>Lifting eye, M16: 3HAC14457-4</p>  <p>xx170000325</p>
4	<p> CAUTION</p> <p>The weight of the gearbox is 140 kg All lifting accessories used must be sized accordingly.</p>	
5	<p>Attach the lifting accessory and lift the gearbox.</p>	<p>Lifting accessory (chain): 3HAC15556-1</p>  <p>xx170000326</p>

Continues on next page

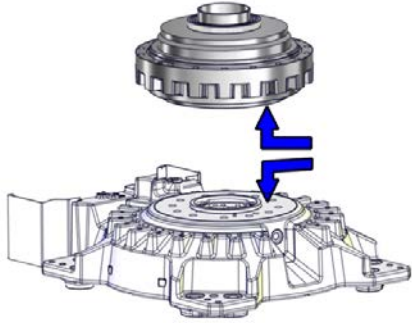
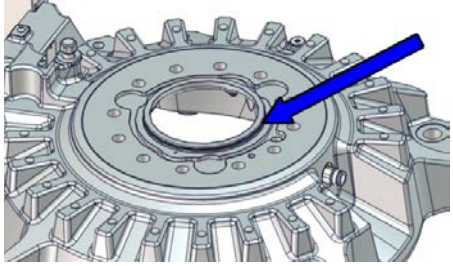
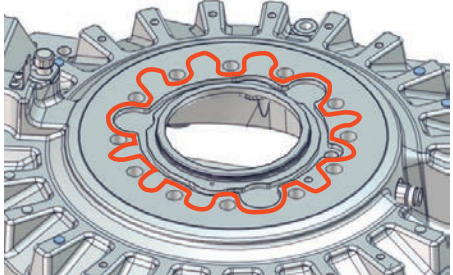
Action	Note
<p>6 Wipe the contact surfaces between gearbox and base clean from any contamination.</p> <p> Note</p> <p>The small o-ring beneath the gearbox is not needed for IRB 6700Inv / IRB 6700I.</p>  <p>xx1700001370</p>	 <p>xx1700000567</p>
<p>7 Check the o-ring on the base. Replace if damaged.</p>	<p>O-ring: 3HAB3772-150.</p>  <p>xx1700001376</p>
<p>8 Apply flange sealant to the mounting interface on the base, between the groove and the screw holes.</p>	<p>Flange sealant: Loctite 574 (-).</p>  <p>xx1700001377</p>

Continues on next page



4 Repair

4.8.2 Replacing the axis-1 gearbox

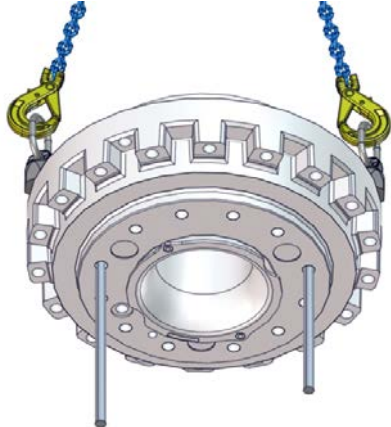

Continued

Action	Note
<p>9 Fit guide pins in opposite holes in the gearbox.</p> <p> Tip</p> <p>Lubricate the guide pins with some grease to make the gearbox slide better.</p>	<p>Guide pin, M20x180: 3HAC048814-002 Always use guide pins in pairs.</p>  <p>xx170000327</p>

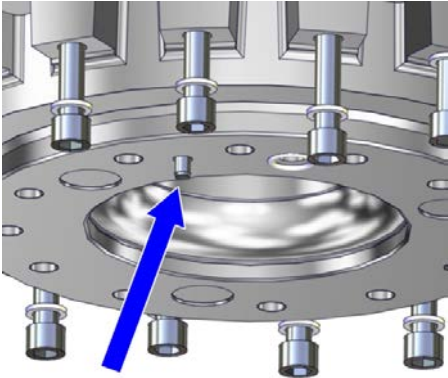
Refitting the gearbox to the base

Action	Note
<p>1 Before the gearbox is being fitted, place the attachment screws that will secure the gearbox to the frame, temporarily in their holes and lock screws with the old o-ring. This is done to prevent the screws from falling out.</p> <p> Note</p> <p>Do not use the new o-ring!</p>	<p>If the attachment screws are not fitted like this at this point, it will be almost impossible to fit the screws later when the gearbox is resting on the base.</p>  <p>xx1400002176</p>
<p>2 Make sure that the locating pin in the base will match its hole in the gearbox.</p>	 <p>xx1400002177</p>

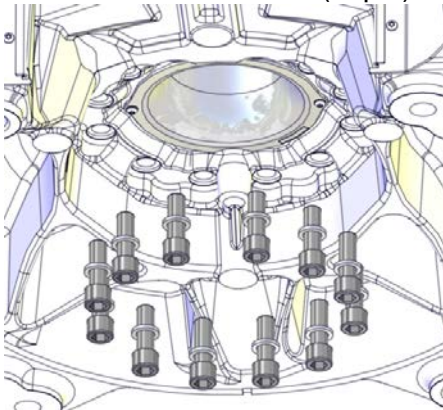
Continues on next page

	Action	Note
3	With all screws in position, lower the gearbox carefully down against the base with guidance from the guide pins.	
4	Lower the lifting accessory so that the chain is no longer stretched.	
5	Fit the attachment screws that secure the gearbox to the base, from underneath.	<p>Attachment screws: M20x60 (12 pcs)</p>  <p>xx1400002172</p>
6	Remove the guide pins and fit the two remaining screws.	
7	<p>Secure the attachment screws.</p>  <p>Tip</p> <p>This procedure is best performed by two persons working together:</p> <ul style="list-style-type: none"> • one underneath the robot base making sure that the bit is being fitted into the screw head holes, all the way until they reach the bottom • one using the torque wrench, tightening the screws from beside the base. 	Tightening torque: 500 Nm.
8	<p>Check the protection tube for damages. Especially inspect the surface for the sealing ring. Replace if damaged.</p>	 <p>xx1700000568</p>
9	Wipe the surfaces of the protection tube and the hole in axis-1 gearbox clean from any contamination.	
10	Put some grease on the protection tube.	

Continues on next page

4 Repair

4.8.2 Replacing the axis-1 gearbox

Continued

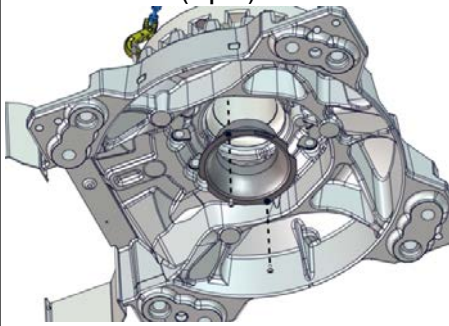
	Action	Note
11	Refit the protection tube to the base. Secure with the two attachment screws.	Screws: M6x16 (2 pcs).  <small>xx1700000561</small>



Refitting the base to the foundation

	Action	Note
1	 CAUTION The weight of the gearbox and base together is 305 kg All lifting accessories used must be sized accordingly.	
2	Stretch the lifting accessories to take the weight of base and gearbox.	
3	Unscrew the screws that secure the base to the support legs and lift up base and gearbox.	
4	Remove the support legs.	
5	Lower the base and gearbox to the foundation.	
6	Secure the base to the foundation.	M24x100 (8 pcs) 550 Nm (screws lubricated with Molykote 1000) 600-725 Nm, typical 650 Nm (screws none or lightly lubricated)

Preparations before refitting the arm system

	Action	Note
1	Remove old residues of flange sealant and other contamination from the contact surfaces on the gearbox.	
2	Wipe clean the contact surfaces from any remaining contamination.	
3	Wipe clean the o-ring groove in the gearbox and apply some grease to the groove.	Grease, Shell Gadus S2: 3HAC042536-001.

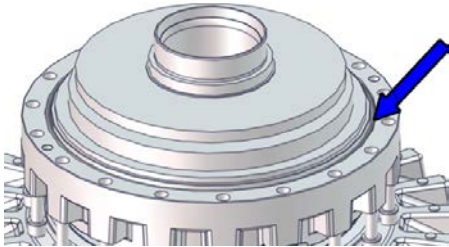
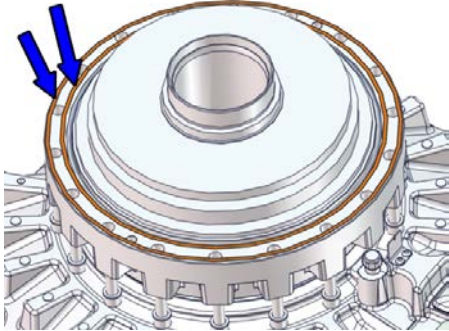
Continues on next page

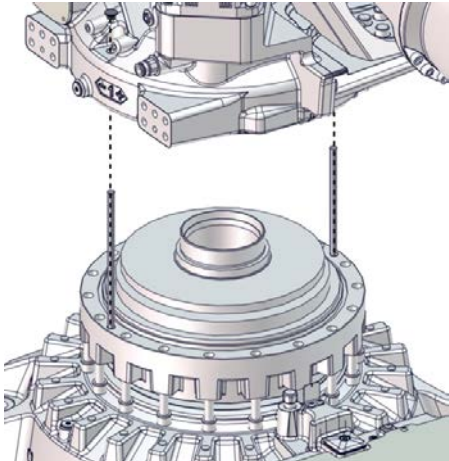
Action	Note
<p>4 Wipe a new o-ring clean, apply some grease to it and replace the old one between base and frame with a new. Install the new o-ring in the groove.</p> <p> Note</p> <p>A new o-ring also needs to be cleaned!</p>	<p>O-ring: 3HAB3772-160. Grease, Shell Gadus S2: 3HAC042536-001.</p>  <p>xx1700000336</p>
<p>5 Apply flange sealant in two strings according to the figure.</p>	<p>Flange sealant, Loctite 574: -.</p>  <p>xx1700000415</p>
<p>6 Apply some grease on:</p> <ul style="list-style-type: none"> • the outside of the bearing • the guiding part of the bearing • the edge of the protection tube • the edge around the gearbox. 	
<p>7 Apply guide pins in the guide pin holes in the gearbox.</p> <p> Tip</p> <p>Lubricate the guide pins with some grease to make the frame slide better.</p>	<p>Guide pin, M16x120: 3HAC062397-001 (2 pcs). Always use guide pins in pairs.</p>  <p>xx1700000329</p>



Continues on next page

4 Repair

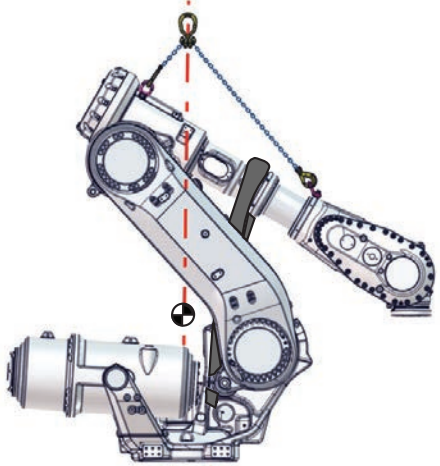

4.8.2 Replacing the axis-1 gearbox

Continued

Refitting the arm system

	Action	Note
1	<p> CAUTION</p> <p>The arm system weighs . 1,300 kg (IRB 6700Inv -300/2.60, -245/2.90) 1,320 kg (IRB 6700I -270/2.60 LID, -210/2.90 LID)</p> <p>All lifting accessories used must be sized accordingly!</p>	
2	<p>Make sure that all lifting accessories still is fitted correctly on the arm system.</p>	<p>See Attachment points of lifting accessory on page 199.</p>
3	<p>If using the Lifting accessory (chain): Attach the upper arm lifting accessory (chain) to an overhead crane (or similar) and then to the lifting eye in the arm house and to the lifting eye in the wrist.</p> <p>Adjust the lengths of the chains so that the lifting hook is located in line with the center of gravity when the robot arm system is lifted, as shown in the figure.</p>	<p>Lifting accessory (chain): 3HAC15556-1</p>  <p>xx170000313</p>
4	<p> WARNING</p> <p>The angle between the two chains may not exceed 90°.</p>	 <p>xx170000319</p>

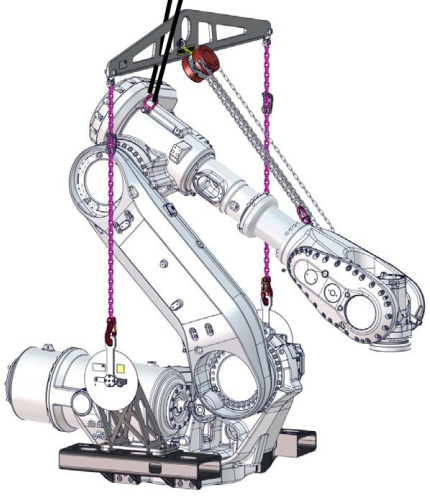
Continues on next page



Action	Note
<p>5 If using the Turning tool: Secure the turning tool chain block to the lifting eye in the wrist. Shorten the chain to make the lift horizontal. Fit a roundsling between the overhead crane hook and the lifting eye in the arm house.</p>	<p>Turning tool: 3HAC073537-001</p>  <p>xx170000695</p>
<p>6 Lift the arm system up, to be able to reach the contact surfaces underneath the frame.</p>	
<p>7 Wipe clean the contact surfaces from any remaining contamination.</p>	
<p>8 Before putting the complete arm system on to the guide pins, make sure that the hole pattern will match and that the guide pins will enter the correct holes in the frame.</p>	
<p>9 Remove the big o-ring that holds the attachment screws in the temporary position and let them drop down on the base.</p> <p> Note</p> <p>Make sure that none of the screws are missing or in the wrong position.</p>	
<p>10 Lift the complete arm system and lower it slowly down over the guide pins, until it is possible to insert the attachment screws manually.</p> <p> CAUTION</p> <p>Do not lower the arm system completely at this stage! The attachment screws must be fitted in two steps. If not, the complete arm system will risk resting on the attachment screws in the wrong position!</p>	
<p>11 Fit the attachment screws manually as far as possible. Lower the complete arm system slowly in steps, until all attachment screws no longer can reach the base, when the arm system is lowered all the way down.</p>	<p>Attachment screws: M16x110</p>
<p>12 Make sure that the complete arm system is lowered all the way down.</p>	

Continues on next page

4 Repair

4.8.2 Replacing the axis-1 gearbox

Continued

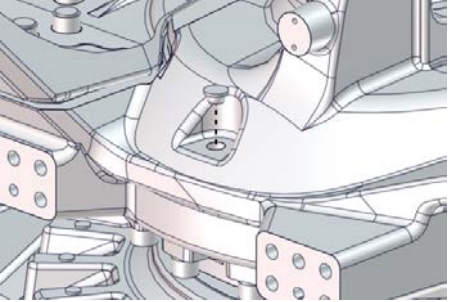
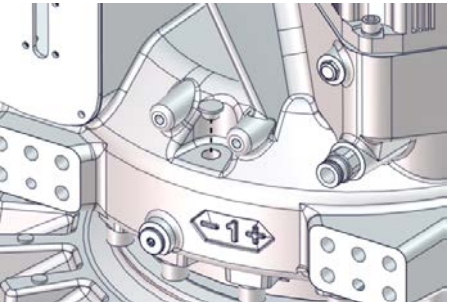
	Action	Note
13	<p> Note</p> <p>The attachment screw at the axis-1 synchronization plate can not be reached to be secured at this stage. Make sure it is still in its place and will not be damaged in the continued procedure.</p>	
14	<p>Secure all screws now possible to reach.</p> <p> Note</p> <p>A bits holder is needed to be able to reach the attachment screws.</p>	<p>Bit holder: 3HAC029090-001. Tightening torque: 300 Nm</p>
15	<p>Manually rotate axis-1 to a position where the remaining attachment screw can be secured.</p>	
16	<p>Remove the guide pins and refit the two plastic protection plugs or the two M16 screws.</p>	 <p>xx170000320</p>  <p>xx170000321</p>

Continues on next page

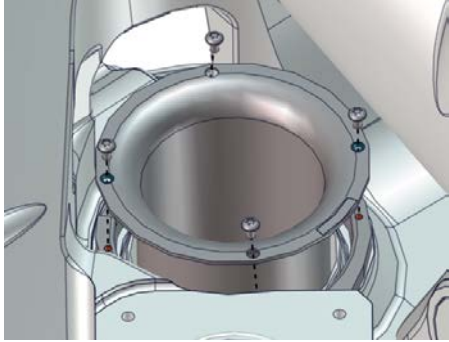
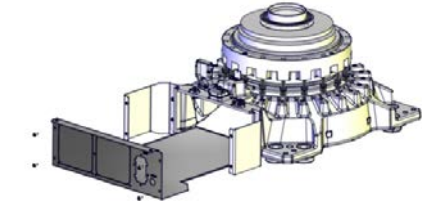
	Action	Note
17	Refit the cable guide in the frame. Secure with the four attachment screws. Apply locking liquid on the screws.	Screws: M6x10 (4 pcs). Locking liquid: Loctite 2400 (or equivalent Loctite 243) (-). Tightening torque: 10 Nm.  xx1700001256
18	Refit the back plate.	 xx1400002171

Preparations before refitting the hub

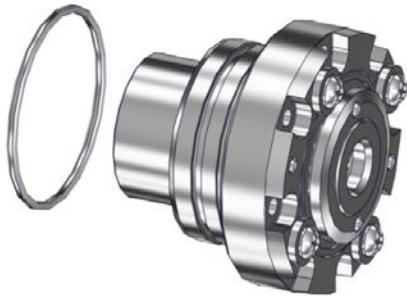
	Action	Note
1	Wipe the hub clean.	
2	Inspect the hole where the hub shall be refitted. Wipe clean if needed.	
3	Make sure the o-ring on the hub is undamaged.  Note Replace if damaged.	 xx1500002039
4	Apply some grease on the o-ring for a better fitting.	

Continues on next page



4 Repair

4.8.2 Replacing the axis-1 gearbox

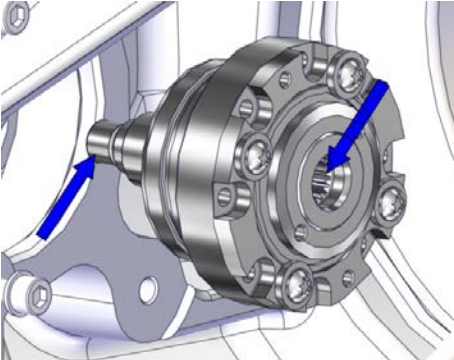
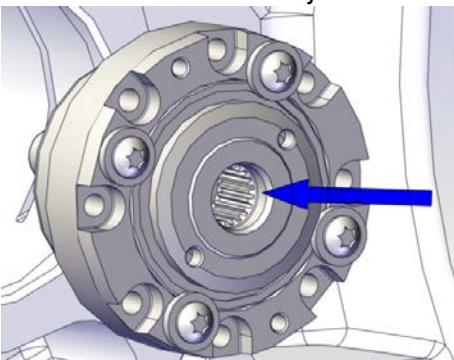

Continued

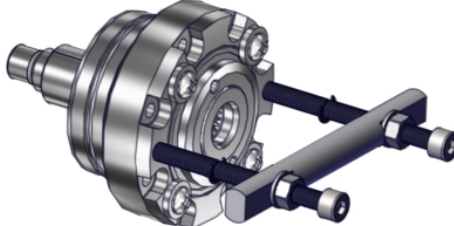
	Action	Note
5	Examine the pinion and the splines in the hub for damages.	 <p>xx1500002082</p>
6	Make sure that there is enough grease on the splines before fitting. If not, apply 1 gram of grease.	<p>Grease: Castrol Molub. Alloy 777-1 NG</p>  <p>xx1500002346</p>

Refitting the hub

	Action	Note
1	Fit the hub tool.	<p>Hub tool: 3HAC071355-001</p>  <p>xx2000001377</p>
2	 CAUTION Whenever parting/mating the hub pinion and gearbox, the gears may be damaged if excessive force is used.	

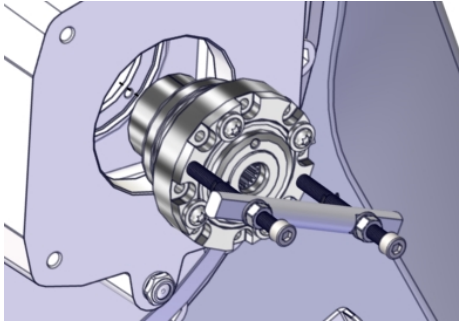
Continues on next page

Action	Note
3 Lift the hub to the gear, and mate the pinon carefully into the gear.	 xx2000001381
4 Remove the hub tool and fit the attachment screws for the hub. Apply locking liquid (Loctite 2400 (or equivalent Loctite 243)) on the screws.	Attachment screws: M6x30 12.9. Loctite 2400 (or equivalent Loctite 243) Quantity: 6 pcs
 Note The number of attachment screws differ depending on gearbox.	
5 Secure the hub.	Tightening torque: 14 Nm.

Securing the axis-1 motor

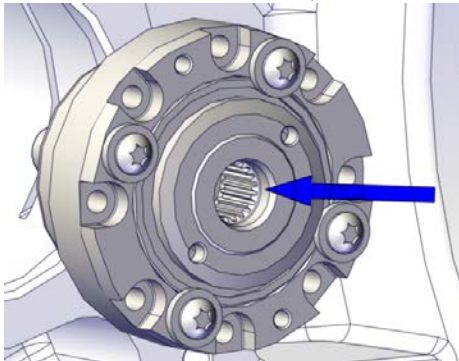



Action	Note
1 Fit guide pins in opposite holes.	Guide pin, M10x150: 3HAC15521-2 Always use guide pins in pairs.
2  CAUTION The motor weighs 27 kg. All lifting accessories used must be sized accordingly.	
3 Apply the lifting accessory.	Lifting accessory, motor: 3HAC14459-1.
4 Fit the rotation tool.	Rotation tool: 3HAB7887-1
5 Make sure that there is enough grease on the splines, before fitting. If not, apply 1 gram of grease.	Grease: Castrol Molub. Alloy 777-1 NG  xx1500002346

Continues on next page

4 Repair

4.8.2 Replacing the axis-1 gearbox

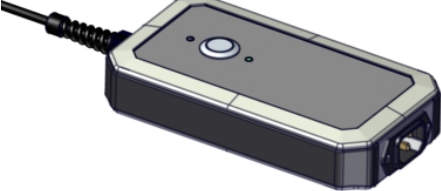
Continued

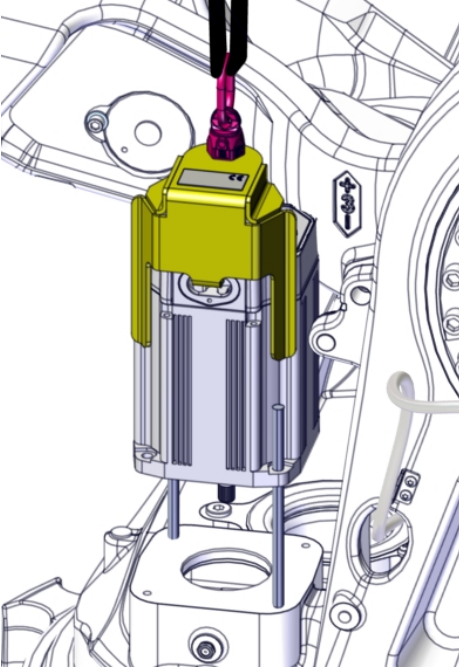
	Action	Note
6	<p>Release the brakes of the axis-1 motor with the brake release tool.</p> <ol style="list-style-type: none">1 Turn off the brake release tool.2 Connect the tool to the R2.MP1 connector.3 Release the brakes by turning on the brake release tool and pressing the brake release button on the tool. <p> DANGER</p> <p>Handling the tool incorrectly will cause serious injury.</p> <p>Read and follow enclosed user instructions for the tool.</p> <p> Note</p> <p>If a 24 VDC power supply is used instead of the brake release tool, connect it to connector R2.MP1:</p> <ul style="list-style-type: none">• pin 2 = 24V• pin 5 = 0V	<p>Brake release tool: 3HAC081310-001 User instructions are enclosed with the tool.</p>  <p>xx2100000666</p>
7	<p> CAUTION</p> <p>Whenever parting/mating motor pinion and hub, the splines may be damaged if excessive force is used.</p>	
8	<p>Lower the motor into position.</p> <ul style="list-style-type: none">• Make sure that the motor pinion is properly mated into the hub.• Make sure that the motor pinion does not get damaged.• Make sure that the direction of the cable gland exit is facing the correct way.	<p>Lifting accessory (chain): 3HAC15556-1 Lifting accessory, motor: 3HAC14459-1.</p>  <p>xx1500002084</p>

Continues on next page

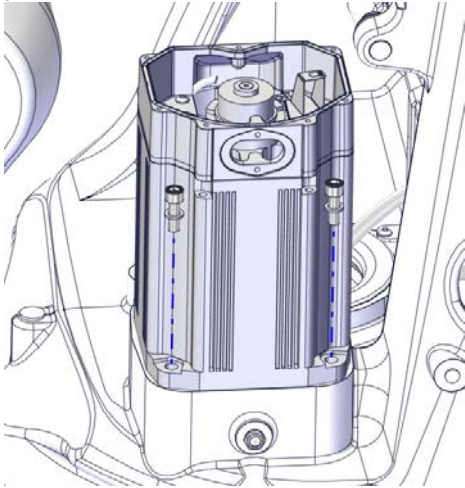
	Action	Note
9	Secure the motor with its attachment screws and washers. Use a bits extender to reach the screws.	Bits extender: 3HAC12342-1 Tightening torque: 50 Nm. Screws: M10x40 quality 12.9 Gleitmo (4 pcs) 
10	Perform a leak-down test (if not already done).	See Performing a leak-down test on page 188 .
11	Disconnect the brake release tool / 24 VDC power supply.	

Connecting the axis-1 motor cables

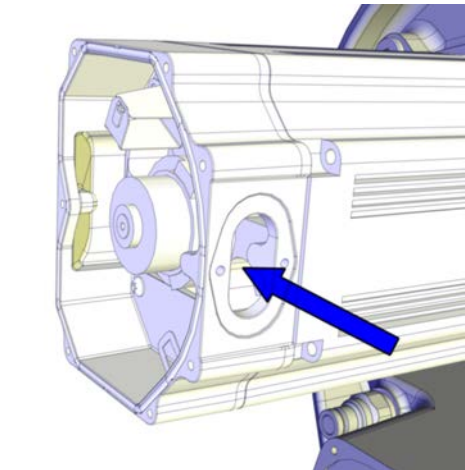

	Action	Note
1	Push the motor cables through the cable gland opening.	

Continues on next page



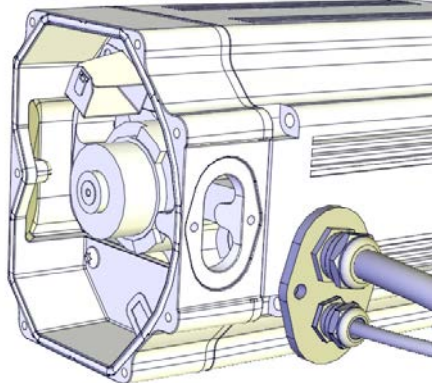
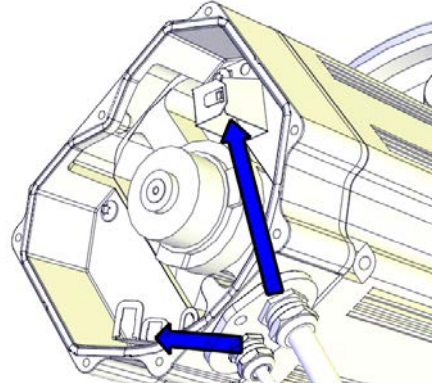

4 Repair

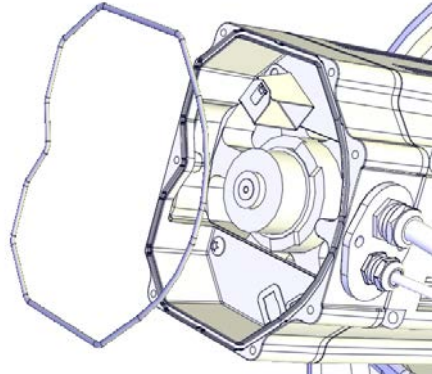
4.8.2 Replacing the axis-1 gearbox

Continued

	Action	Note
2	Refit the cable gland cover.  Note Replace the gasket if damaged.	 xx1200001067
3	Connect the motor cables. Connect in accordance with the markings on the connectors.	 xx1200001066
4	Inspect the o-ring.  Note Replace if damaged.	O-ring, axis-1: 3HAC054692-002 O-ring, axis-2: 3HAC054692-002 O-ring, axis-3: 3HAC054692-002 O-ring, axis-4: 3HAC054692-001  xx1200001070
5	Wipe clean o-ring and o-ring groove.	

Continues on next page

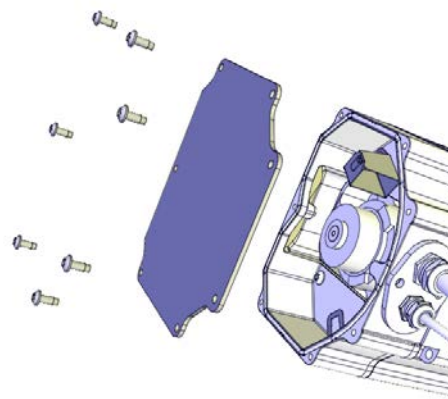
	Action	Note
6	<p>Refit the o-ring.</p> <p> Tip</p> <p>Lubricate the o-ring with some grease for a better fitting in the groove.</p>	
7	<p> CAUTION</p> <p>When fitting the motor cover, make sure that none of the cables inside will be damaged.</p>	
8	<p>Refit the motor cover with it's attachment screws.</p> <p> Note</p> <p>Do not reuse the self-threading attachment screws. Replace with standard attachment screws or the threads will be damaged.</p> <p> Note</p> <p>Make sure the o-ring is undamaged and properly fitted.</p>	<p>Attachment screws: M5x12 8.8 (7 pcs)</p>  <p>xx1200001135</p>
9	<p>Make sure that the covers are tightly sealed.</p>	

Refilling oil in the gearbox

	Action	Note
1	<p>Refill oil in the gearbox.</p> <p>Because of the risk of getting air bubbles into axis-1 gear in inverted position when filling oil, it is recommended to fill the gearbox with oil before lifting up the robot to inverted position.</p>	<p>See Changing oil, axis-1 gearbox on page 149.</p>

4 Repair

4.8.2 Replacing the axis-1 gearbox

Continued

Refitting the cable harness in the base

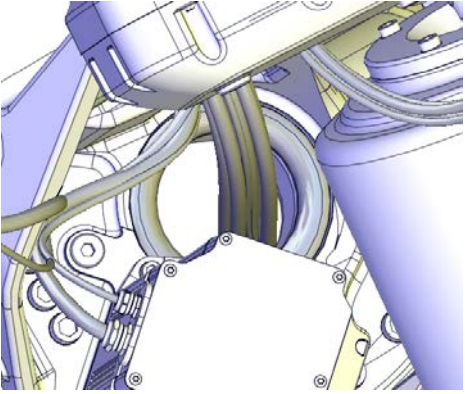
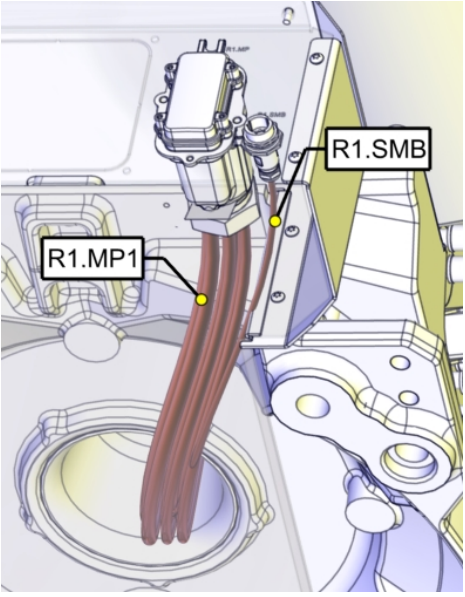
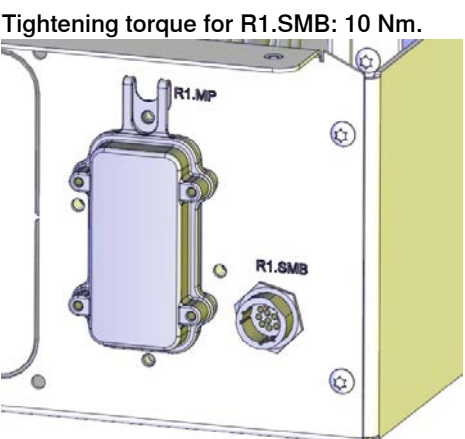
	Action	Note
1	<p>Run the cables through the protection tube in this order:</p> <ul style="list-style-type: none"> • R1.MP • R1.SMB <p>If necessary, lubricate the cables with grease to make them run more smoothly.</p>	 <p>xx130000732</p>
2	<p>Run the cables correctly aligned:</p> <ul style="list-style-type: none"> • Make sure that the cables are not twisted. Each cable must be in line with its position on the base plate. • Make sure that the R1.SMB cable will run on the correct side of the R1.MP1, see the figure. 	 <p>xx130000736</p>
3	<p>Make sure that the markings on the cables are facing the base cover, when connected.</p>	
4	<p>Connect connectors R1.MP and R1.SMB.</p>	<p>Tightening torque for R1.SMB: 10 Nm.</p>  <p>xx130000591</p>

Continues on next page

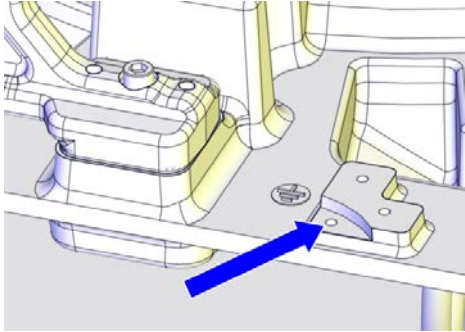
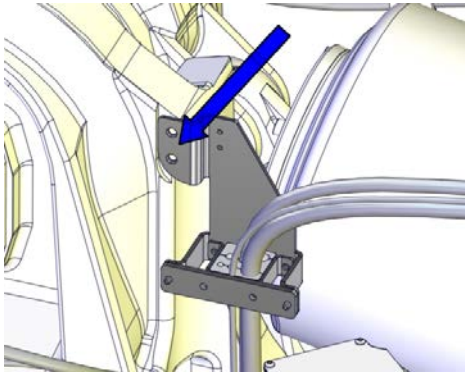
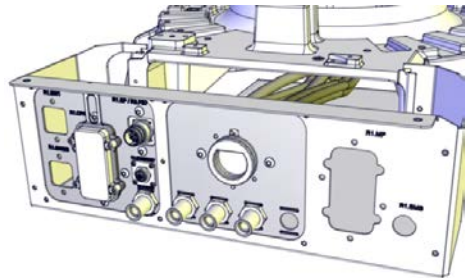
	Action	Note
5	Connect the earth cable.	<p>Screw dimension: M6x16. Washer dimension: 6.4x17x3.</p>  <p>xx1400000354</p>
6	If used, run the DressPack cables through the protection tube in the base.	
7	If used, run the DressPack hoses through the protection tube in the base. Make sure that the hoses are running correctly and are not twisted!	
8	If used, fit the bracket that hold the DressPack to the frame.	 <p>xx1400000078</p>
9	If used, connect the DressPack cable package on the base plate.	 <p>xx1200000052</p>

Continues on next page

4 Repair

4.8.2 Replacing the axis-1 gearbox

Continued

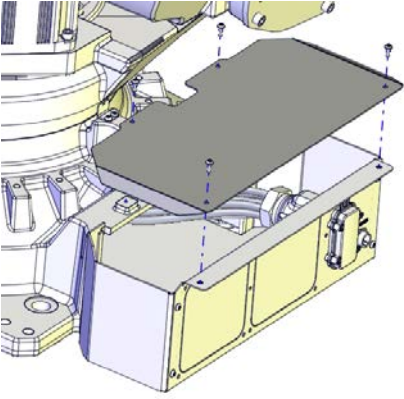
	Action	Note
10	Refit the base cover.	 <p>xx1300000561</p>

Refitting the mechanical stop and remaining cable brackets

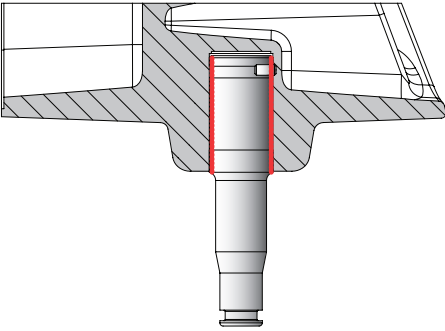
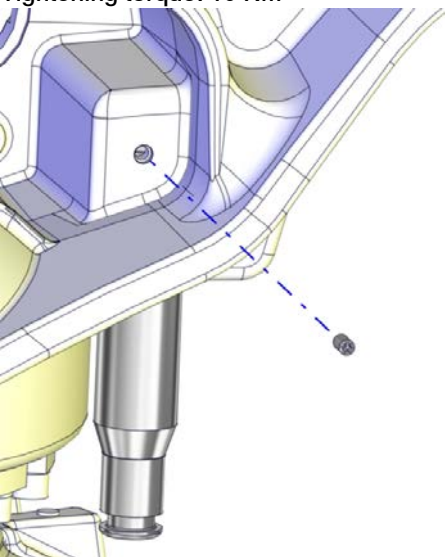
	Action	Note
1	<p><i>Foundry Plus:</i> Apply Mercasol on the surfaces shown in the figure, on stop pin and in the hole as shown in the figure.</p>	 <p>xx1400000378</p>
2	<p>Refit the mechanical stop pin and secure it with the attachment screw. Locking liquid (Loctite 243) on screw.</p>	<p>Tightening torque: 10 Nm</p>  <p>xx1400002179</p>

Continues on next page

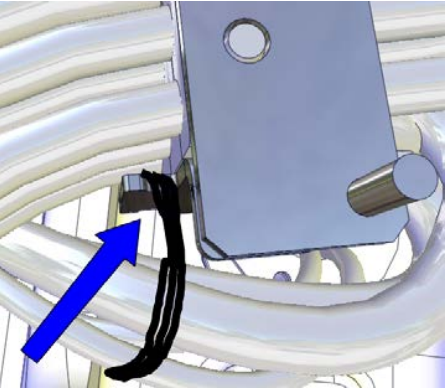
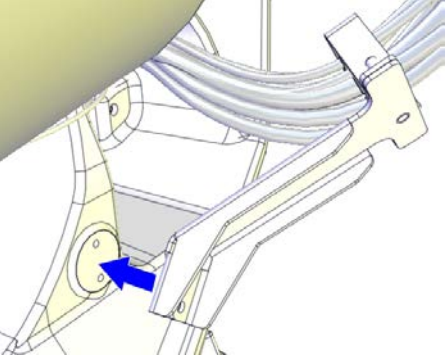
	Action	Note
3	Secure the cable harness inside the frame hole with a cable strap.	 <p data-bbox="991 703 1098 723">xx1200001237</p>
4	Refit the cable bracket on the frame.	 <p data-bbox="991 1122 1098 1142">xx1200001246</p>

Preparations before lifting up the robot to inverted position

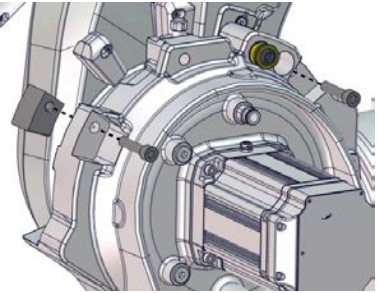
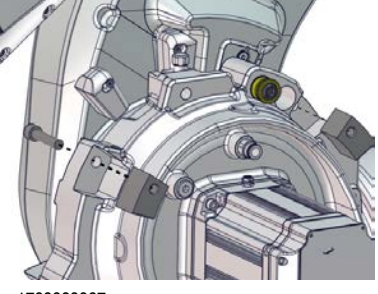
	Action	Note
1	Remove the two service stops from maintenance position, if previously moved there.	 <p data-bbox="1062 1581 1169 1601">xx1700000068</p>
2	Fit the service stops in their parking position.	 <p data-bbox="1062 1939 1169 1960">xx1700000067</p>

Continues on next page



4 Repair

4.8.2 Replacing the axis-1 gearbox

Continued

	Action	Note
3	Fasten the fork lift accessory.	See user instructions enclosed with the fork lift accessory. Fork lift accessory set: 3HAC058825-001.
4	Remove the bolts securing the robot to the foundation.	

Orienting and securing the robot

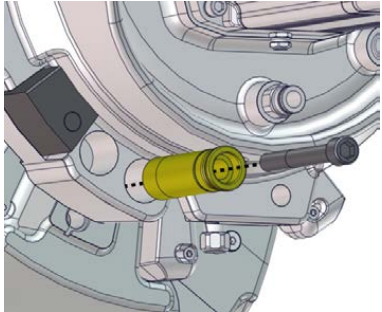
	Action	Note
1	Lift the robot using the fork lift accessory.	See user instructions enclosed with the fork lift accessory.
2	Move the robot close to its installation location.	
3	Rotate the robot into inverted position using the turning tool or using a fork lift truck with a rotator attachment.  DANGER Make sure that there is enough space underneath the robot. See user instructions for the turning tool.	See user instructions enclosed with the turning tool.
4	Guide the robot using two M24 screws while lifting it into its mounting position.	
5	Fit the bolts and washers in the base attachment holes.  Note Lightly lubricate screws before assembly.  CAUTION If high stress on screws are suspected, replace used screws with new ones.	Suitable screws, lightly lubricated: M24x100 (8 pcs), 8.8. Suitable washer: 4 mm flat washer. Screw tightening yield point utilization factor (v) (according to VDI2230): 90% (v=0.9). Tightening torque: 550 Nm (screws lubricated with Molykote 1000) 600-725 Nm, typical 650 Nm (screws none or lightly lubricated)
6	Tighten bolts in a crosswise pattern to ensure that the base is not distorted.	
7	Remove the yellow sleeve and transportation lock screw from the transportation and turning position.	 xx1700000269

Continues on next page

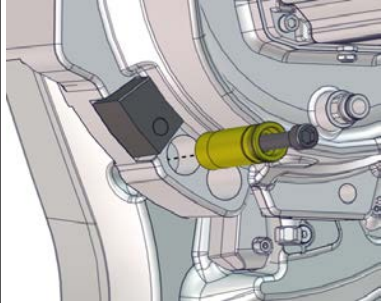
	Action	Note
8	Fasten the yellow sleeve and transportation lock screw in its parking position.	<p>Tightening torque: 70 Nm \pm 15 Nm.</p>  <p>xx1700000270</p>

Concluding procedure

	Action	Note
1	Re-calibrate the robot.	<p>Axis Calibration is described in Calibrating with Axis Calibration method on page 694.</p> <p>General calibration information is included in section Calibration on page 683.</p>
2	 <p>DANGER</p> <p>Make sure all safety requirements are met when performing the first test run. See Test run after installation, maintenance, or repair on page 97.</p>	

4 Repair

4.8.3 Replacing the axis-2 gearbox

4.8.3 Replacing the axis-2 gearbox

Space required beside

This section describes how to replace the gearbox without needing to remove the cable harness and DressPack cable package (if installed) from the robot.

The described procedure requires free space on the floor, in front of the lower arm, so that the upper and lower arm can be laid down with the cabling still attached to the robot. There should be enough space to place two pallets on the floor. If needed, run axis-1 into a position that gives the required space.



DANGER

The base shall be fitted to the foundation when performing this procedure! Valid in both examples described below!



Note

Using this method to replace the gearbox with cable harness and DressPack fitted, is only a recommendation. If it is not possible to put the arm system close enough to the robot and keep the cable harness partly fitted, it is necessary to remove the cable harness and DressPack in base and frame first.

Location of the axis-2 gearbox

The axis-2 gearbox is located as shown in the figure.

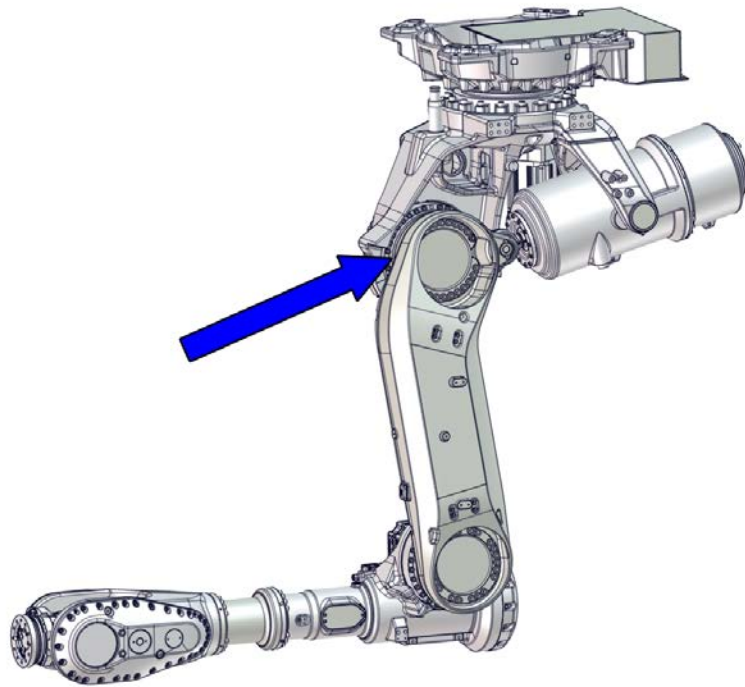

xx1700000373

Continues on next page

**Note**

The robot must be taken down and secured floor standing to perform this replacement procedure.

How to do this is described in the removal procedure in this section.

**DANGER**

Always lock the position of the lower arm, using the yellow sleeve and transportation lock screw, before attempting to lift the robot.

Summary of the replacement procedure

This is a brief summary of the replacement procedure, containing the major actions to be performed.

- 1 Lift down the robot to floor standing.
- 2 Remove the upper and lower arm together, as a package.
- 3 Replace the axis-2 gearbox.

Spare parts

Spare parts	Article number	Note
Axis-2 gearbox	See <i>Product manual, spare parts - IRB 6700/IRB 6700Inv.</i>	

Required tools and equipment

Equipment, etc.	Article number	Note
Oil collecting vessel	-	The capacity of the vessel must be sufficient to take the complete amount of oil.
Oil dispenser	-	One example of oil dispenser can be found in section Type of lubrication in gearboxes on page 147 .
Lifting eye, M12	3HAC16131-1	
Lifting eye, M16	3HAC14457-4	
Bits extender	3HAC12342-1	300 mm, bits 1/2"
Fender washer	-	Outer diameter: minimum 26 mm, maximum 30 mm, hole diameter: 13 mm, thickness: 3 mm.
Lifting shackle, 2 pcs	-	SA-10-8-NA1
Roundsling, 1.5 m	-	Lifting capacity: 2,000 kg.
Roundsling, 1 m	-	Lifting capacity: 1,000 kg.
Lifting accessory (chain)	3HAC15556-1	Lifting instruction 3HAC15880-2 enclosed.
Rotation tool	3HAB7887-1	Used to rotate the motor pinion.
24 VDC power supply	-	Used to release the motor brakes.

Continues on next page

4 Repair

4.8.3 Replacing the axis-2 gearbox

Continued

Equipment, etc.	Article number	Note
Removal tool motor M12	3HAC14631-1	Used to push out the motor, if necessary. Always use removal tools in pairs.
Pallet		Used for putting down removed parts from robot.
Guide pin, M16x150	3HAC13120-2	Always use guide pins in pairs.
Guide pin, M16x200	3HAC13120-3	Always use guide pins in pairs.
Guide pin, M12x150	3HAC13056-2	Always use guide pins in pairs.
Guide pin, M12x200	3HAC13056-3	Always use guide pins in pairs.
Aligning tool	3HAC046645-003	Used for aligning the gearbox against the frame, so that the play in the motor does not need to be adjusted.
Guide pin, M10x150	3HAC15521-2	Always use guide pins in pairs.
Lifting accessory, gearbox	3HAC046128-001	
Hydraulic cylinder	3HAC11731-1	To be used with the press tool.
Hydraulic pump 80 MPa	3HAC13086-1	To be used with the hydraulic cylinder.
Threaded bar, M16x340	-	
Leak-down tester	-	
Calibration tool box, Axis Calibration	3HAC055412-001	Delivered as a set of calibration tools.
Standard toolkit	-	Content is defined in section Standard toolkit on page 724 .

Consumables

Equipment, etc	Article number	Note
Grease	3HAC042536-001	Shell Gadus S2 Used to lubricate o-rings.
O-ring	3HAB3772-107	D=102x3 Used on motor flange.
O-ring	3HAC054692-002	D=169.5x3 Used on motor cover.
O-ring	3HAB3772-144	D=309.3x3.1 Used on gearbox.
VK cover	3HAA2166-28	VK 28x7
Locking liquid (Loctite 2701)	-	

Required documents

Document name	Document number	Note
Technical reference manual - Lubrication in gearboxes	3HAC042927-001	
Directions for use - Fork lift accessory 3HAC058825-001	3HAC060303-001	

Continues on next page

Document name	Document number	Note
Directions for use - Lifting and rotating accessory for IRB 6700Inv/IRB6700I	3HAC073537-003	

Deciding calibration routine

Decide which calibration routine to be used, based on the information in the table. Depending on which routine is chosen, action might be required prior to beginning the repair work of the robot, see the table.

	Action	Note
1	<p>Decide which calibration routine to use for calibrating the robot.</p> <ul style="list-style-type: none"> Reference calibration. External cable packages (DressPack) and tools can stay fitted on the robot. Fine calibration. All external cable packages (DressPack) and tools must be removed from the robot. 	
	<p>If the robot is to be calibrated with reference calibration:</p> <p>Find previous reference values for the axis or create new reference values. These values are to be used after the repair procedure is completed, for calibration of the robot.</p> <p>If no previous reference values exist, and no new reference values can be created, then reference calibration is not possible.</p>	<p>Follow the instructions given in the reference calibration routine on the FlexPendant to create reference values.</p> <p>Creating new values requires possibility to move the robot.</p> <p>Read more about reference calibration for Axis Calibration in Reference calibration routine on page 695.</p>
	<p>If the robot is to be calibrated with fine calibration:</p> <p>Remove all external cable packages (DressPack) and tools from the robot.</p>	

Removing the axis-2 gearbox

Use these procedures to remove the gearbox.

Follow the order of the separate procedures according to the order they are presented.



CAUTION

When performing these procedures, the cable harness will still be fitted or partly fitted to the robot. Use extreme caution not to cause any damage to the cable harness!

Securing the lower arm

Use this procedure to secure the lower arm.



	Action	Note
1	Jog axis 2 to -35°.	

Continues on next page

4 Repair

4.8.3 Replacing the axis-2 gearbox

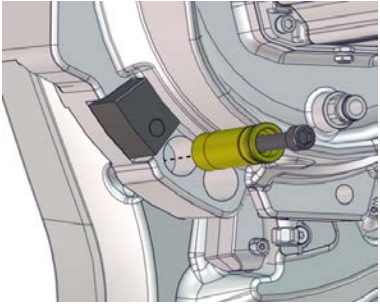

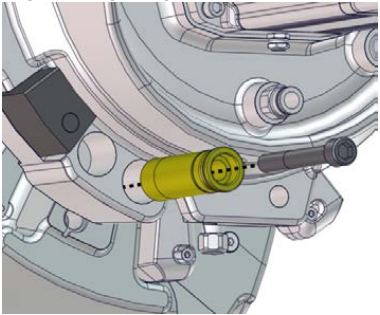
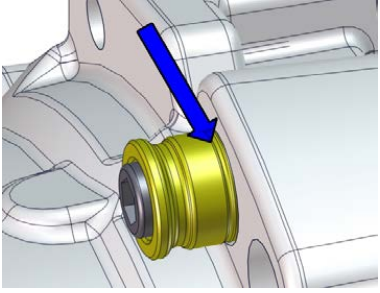

Continued

	Action	Note
2	Remove the transportation lock screw and the yellow sleeve from the parking position.	 <p>xx1700000270</p>
3	<p>Insert the yellow sleeve and the transportation lock screw in the hole at the locking position. Insert the sleeve all the way so that the marking in the sleeve is aligned with the casting, see figure. Tighten the screw.</p> <p> DANGER</p> <p>Always use the transportation lock screw and sleeve to lock the lower arm at transportation, turning and floor standing.</p>	<p>Tightening torque: 70 Nm ±15 Nm.</p>  <p>xx1700000269</p>  <p>xx1600002114</p>

Lifting down the robot from inverted position

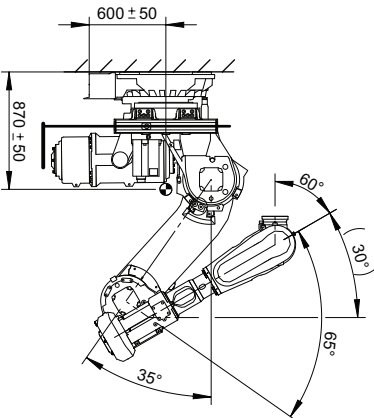
	Action	Note
1	<p> DANGER</p> <p>The robot must always be secured to the foundation if any kind of repair or maintenance work is to be performed. For some repair work support legs are required.</p>	<p>Suitable screws, lightly lubricated: M24x100 (min. 4 pcs) For hole configuration, see Hole configuration, base on page 66.</p>
2	Verify that the lower arm is secured with the transportation lock screw.	
3	Remove any payload and tools from the robot.	DressPack can stay fitted.

Continues on next page



	Action	Note
4	<p>Jog the robot into position:</p> <ul style="list-style-type: none"> • Axis 1: 0° • Axis 2: already in position and locked with the transportation lock screw, do not jog! • Axis 3: +65° • Axis 4: 0° • Axis 5: +60° • Axis 6: no significance 	 <p>xx1700000555</p>
5	<p> DANGER</p> <p>Turn off all:</p> <ul style="list-style-type: none"> • electric power supply • hydraulic pressure supply • air pressure supply <p>to the robot, before entering the safeguarded space.</p>	
6	<p>Disconnect the robot cables at the base.</p>	
7	<p> CAUTION</p> <p>The weight of the IRB 6700Inv / IRB 6700I robot is 1,750 kg All lifting accessories used must be sized accordingly.</p>	
8	<p>Install the fork lift pockets to the robot.</p> <p> DANGER</p> <p>Handling the tool incorrectly will cause serious injury. Read and follow enclosed user instructions for the tool.</p>	<p>See user instructions enclosed with the fork lift accessory set. Fork lift accessory set: 3HAC058825-001.</p>

Continues on next page

4 Repair

4.8.3 Replacing the axis-2 gearbox

Continued

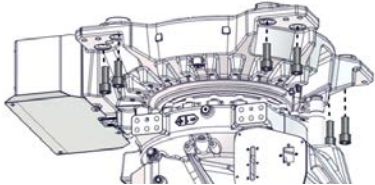
	Action	Note
9	<p>Choose one of the following lifting methods:</p> <ul style="list-style-type: none"> Lifting and turning with the fork lift (rotator attachment required): <ol style="list-style-type: none"> 1 Insert the forks of the fork lift truck into the fork lift pockets, as far as possible. 2 Raise the forks of the fork lift truck to make sure that the weight of the robot rests on the forks. <p> Tip</p> <p>Two M16 screws can be fitted to the fork lift pockets, to press the forks against the pockets and make the lift more stable.</p> Lifting and turning with the turning tool and overhead crane: <ol style="list-style-type: none"> 1 Install and use the turning tool according to enclosed user instructions. <p> DANGER</p> <p>Handling the tool incorrectly will cause serious injury. Read and follow enclosed user instructions for the tool.</p> 	<p>See user instructions enclosed with the turning tool. Turning tool: 3HAC073537-001.</p>
10	Remove the bolts that secure the robot to the foundation.	<p>Quantity: 8 pcs.</p>  <p>xx1600002098</p>
11	Rotate the robot to floor standing position.	Follow the user instructions enclosed with the turning tool.
12	<p>Lower and secure the robot to the floor. (Or to support legs, if replacing the axis-1 gearbox.)</p> <p>The lifting accessories can be kept installed if they are not in the way for the upcoming service procedure.</p>	Attachment screws: M24x100 (min. 4 pcs required to perform service)



Preparations before replacing the axis-2 gearbox

	Action	Note
1	Decide which calibration routine to use, and take actions accordingly prior to beginning the repair procedure.	

Continues on next page

	Action	Note
2	 DANGER Turn off all: <ul style="list-style-type: none"> • electric power supply • hydraulic pressure supply • air pressure supply to the robot, before entering the safe-guarded space.	
3	Begin draining the gearbox.	See Draining the axis-2 gearbox on page 157 .

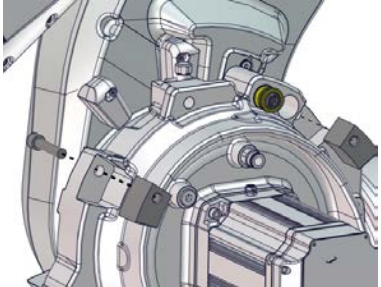
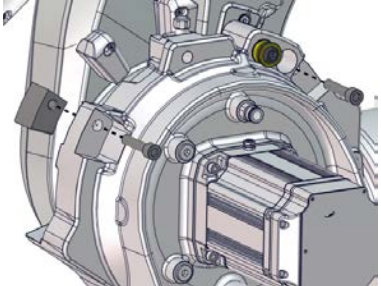
Unloading the balancing device

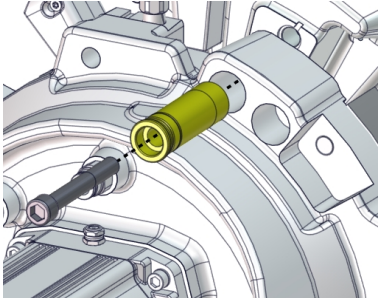

	Action	Note
1	Verify that the robot is secured to the foundation.	Attachment screws: M24x100 (8 pcs).
2	Remove the two service stops from their parking position.	 xx170000067
3	Fit the service stops in maintenance position.	Tightening torque: 70 Nm ±15 Nm.  xx170000068
4	Remove the transportation lock screw and yellow sleeve from locking position.  Note It is only allowed to remove the transportation lock screw and sleeve, if the service stops are in maintenance position, when the robot is floor standing.	 xx1700000347

Continues on next page

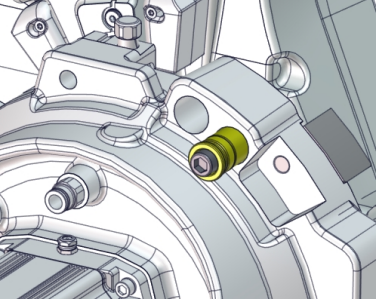
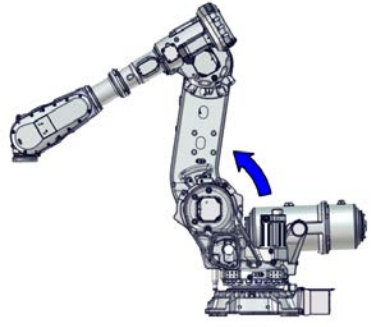

4 Repair

4.8.3 Replacing the axis-2 gearbox

Continued

	Action	Note
5	Fit the transportation lock screw and the yellow sleeve in their parking position.	 xx170000348
6	Jog axis 2 to -4° to be able to insert the relief screws.	 xx1700001404
7	Remove the covers on the balancing device.  Note The covers have to be refitted after repair or maintenance.	 xx170000451

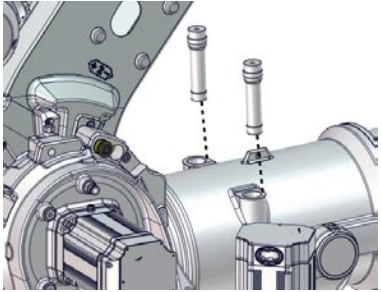
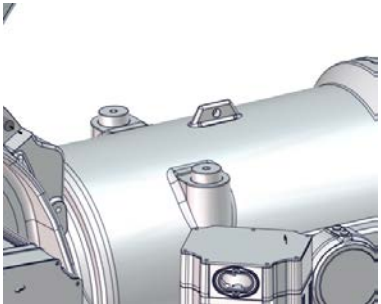
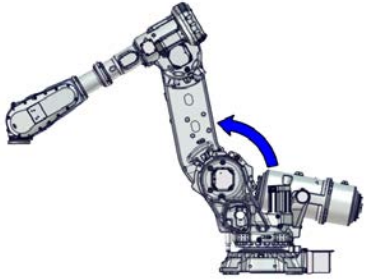
Continues on next page

	Action	Note
8	<p>Fit the relief screws to unload the balancing device.</p> <p> DANGER</p> <p>Do not remove the relief screws when the balancing device is removed from the robot.</p>	<p>Tightening torque: 70 Nm±15 Nm Relief screws, 3HAC058129-001</p>  <p>xx1700000070</p>  <p>xx1700000560</p>
9	<p>Jog axis 2 to +15°.</p>	 <p>xx1700001405</p>
10	<p> DANGER</p> <p>Turn off all:</p> <ul style="list-style-type: none"> • electric power supply • hydraulic pressure supply • air pressure supply <p>to the robot, before entering the safeguarded space.</p>	

Continues on next page

4 Repair

4.8.3 Replacing the axis-2 gearbox

Continued



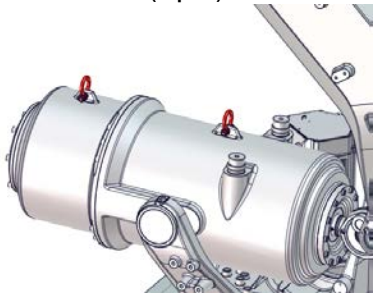
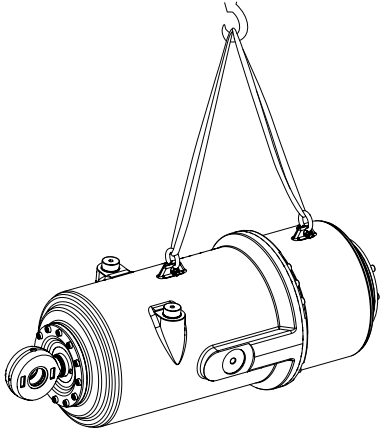

Attaching lifting accessories to the balancing device

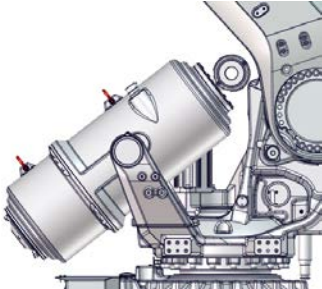
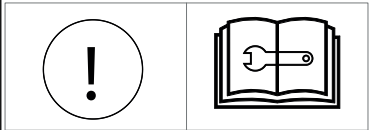
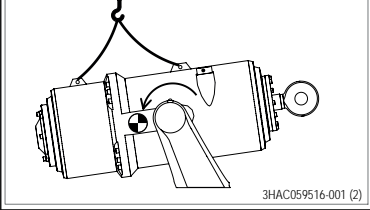
	Action	Note
1	 CAUTION The weight of the balancing device (excluding cradle) is 305 kg All lifting accessories used must be sized accordingly.	
2	Fasten lifting shackles on the balancing device.	SA-10-8-NA1 (2 pcs)  xx170000086
3	Fasten the lifting slings.	Roundsling, 1 m (2 pcs) Lifting capacity: 1,000 kg.  xx170000087

Continues on next page

	Action	Note
4	<p>Raise the lifting slings to take the weight of the balancing device.</p> <p> CAUTION</p> <p>The balancing device is heavy at the back, and will tip over when the link ear is loosened.</p>  <p>xx170000322</p>	  <p>3HAC059516-001 (2)</p> <p>xx1600002060</p>

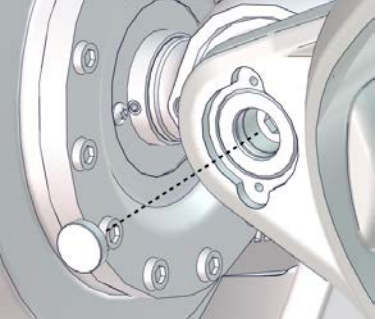
Removing the shaft in the front (link ear)

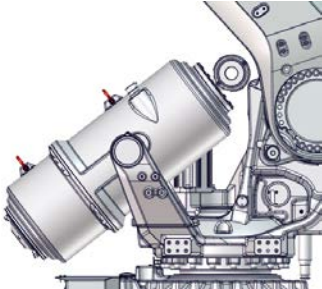
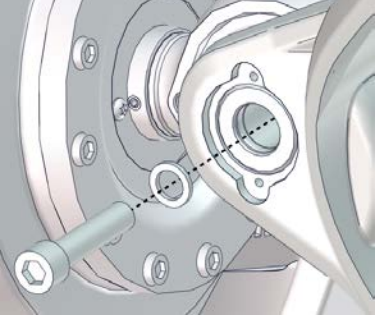
	Action	Note
1	<p>Remove the VK cover at the link ear.</p> <p> Note</p> <p>Make sure that the lifting accessories hold the weight of the balancing device.</p> <p> Tip</p> <p>Use high pressure air to remove the VK covers.</p>	<p>It is possible to drive a screwdriver (or similar) through the VK cover, as close as possible to the center of the VK cover and pull it out.</p>  <p>xx170000088</p>
2	<p>Remove the attachment screw and washer at the link ear.</p> <p> CAUTION</p> <p>The balancing device is heavy at the back, and will tip over when the link ear is loosened.</p>  <p>xx170000322</p>	 <p>xx170000089</p>

Continues on next page

4 Repair

4.8.3 Replacing the axis-2 gearbox

Continued

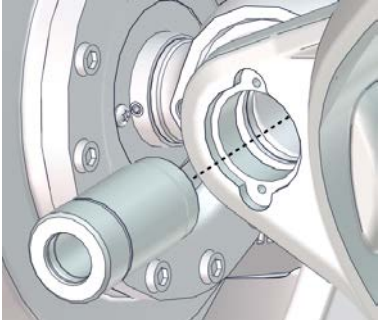
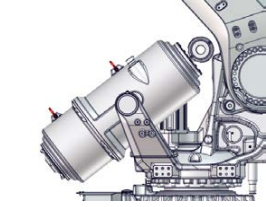
	Action	Note
3	Use the dismantle and mounting tool and pull the shaft out.	Dismantle and mounting tool set: 3HAC028920-001 Press Tool M  xx170000090
4	Carefully lower the lifting device to let the balancing device rest on the frame.	 xx1700000322

Robot position

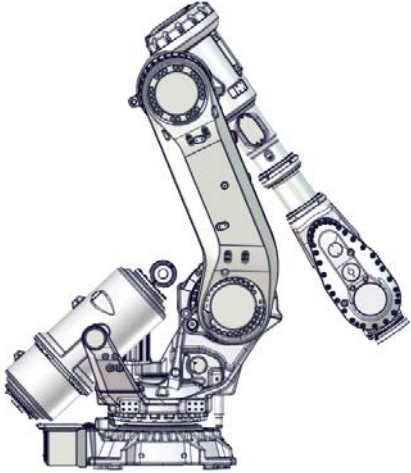



	Action	Note
1	Follow the procedure of replacing the axis-2 gearbox to get the robot prepared for attachment of the lifting accessories for lift of the un-separated lower and upper arm.	See Replacing the axis-2 gearbox on page 612 .
2	Jog the robot into position: <ul style="list-style-type: none"> • Axis 1: position the axis 1 to be able to put down the arm system after removal • Axis 2: -15° • Axis 3: $+70^{\circ}$ (approximately) • Axis 4: 0° • Axis 5: 0° (-90° if DressPack is installed) • Axis 6: 0° ($+90^{\circ}$ if DressPack is installed) 	 xx1700000374

Continues on next page

	Action	Note
3	 DANGER Turn off all: <ul style="list-style-type: none"> • electric power supply • hydraulic pressure supply • air pressure supply to the robot, before entering the safe-guarded space.	

Attaching lifting accessories to the lower and upper arm

Use this procedure to attach the lifting accessories.

	Action	Note
1	 CAUTION The lower and upper arms together weigh (according to variants) 650 kg. All lifting accessories used must be sized accordingly.	
2	Fit a lifting eye with a fender washer in the arm house.  xx1400002196	Lifting eye, M12: 3HAC16131-1 Fender washer: Outer diameter: minimum 26 mm, maximum 30 mm, hole diameter: 13 mm, thickness: 3 mm.  xx1700000376
3	Attach the Lifting accessory (chain) to an overhead crane (or similar), then to the lifting eye in the arm house.	Lifting accessory (chain): 3HAC15556-1  xx1700000377

Continues on next page

4 Repair

4.8.3 Replacing the axis-2 gearbox

Continued

	Action	Note
4	Raise the overhead crane to stretch the chain.	
5	To release the brake, connect the 24 VDC power supply. Connect to connector R2.MP2, axis-2 motor: <ul style="list-style-type: none">• + = pin 2• - = pin 5	

Loosening the cable brackets

Use this procedure to loosen required cable brackets.

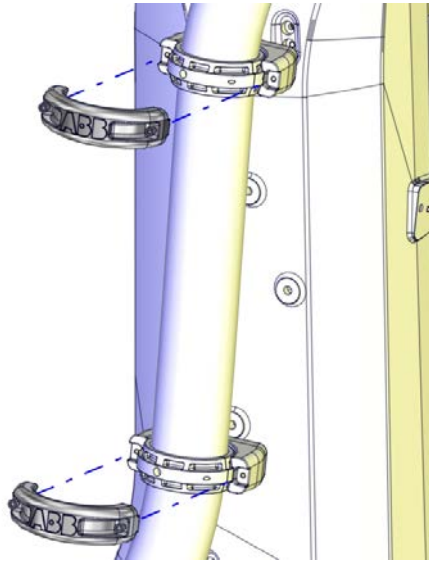
	Action	Note
1	If robot is equipped with DressPack: <ul style="list-style-type: none">• Open the two ball joint housings from the lower arm and lift away the cabling from the ball joint housings.	How to remove the DressPack cable package is described in more detail in the product manual "IRB 6700 DressPack". For article number see References on page 10 .  xx140000195

Continues on next page

4.8.3 Replacing the axis-2 gearbox
Continued

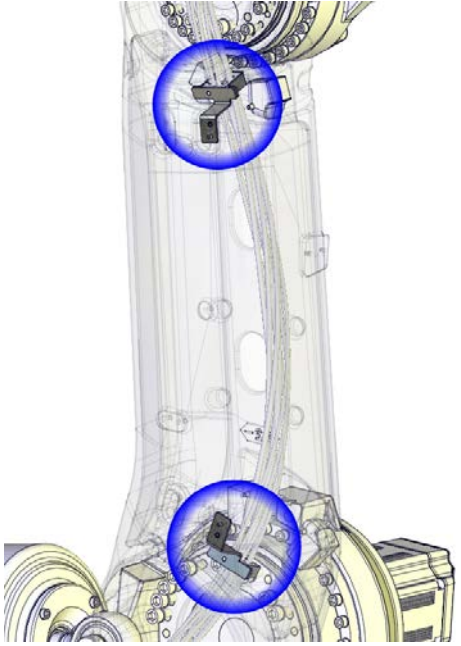
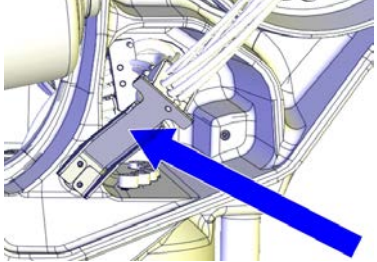
	Action	Note
2	<p>Unscrew the attachment screws that secure the axis-2 lower arm metal clamp and the axis-3 lower arm metal clamp located on the inside of the lower arm by removing the attachment screws.</p> <p> Note</p> <p>The screws are reached from outside the lower arm.</p>	 <p>xx1300000540</p>
3	<p>Unscrew the attachment screws of the cable bracket on the frame and let it hang loose.</p>	 <p>xx1200001283</p>

Fitting guide pins to the lower arm

Use this procedure to prepare the removal of the lower arm.

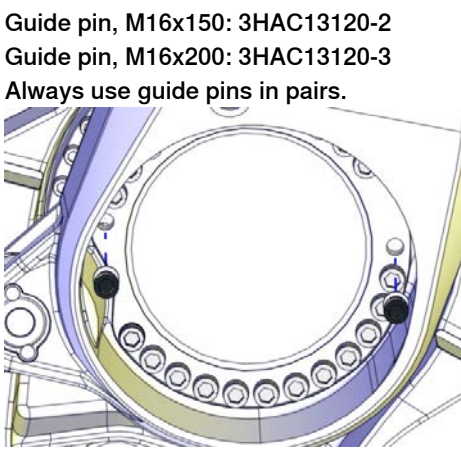
	Action	Note
1	<p>Remove two attachment screws in opposite holes and replace them with guide pins.</p> <p> Tip</p> <p>Lubricate the guide pins with some grease to make the lower arm slide better.</p>	<p>Guide pin, M16x150: 3HAC13120-2 Guide pin, M16x200: 3HAC13120-3 Always use guide pins in pairs.</p>  <p>xx1400002181</p>

Continues on next page

4 Repair

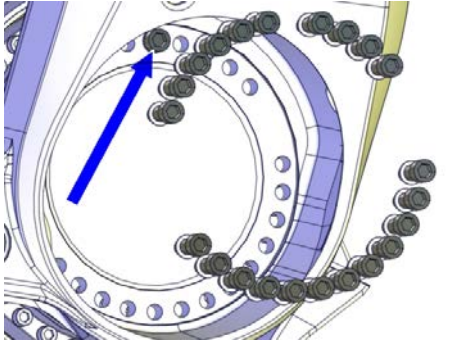

4.8.3 Replacing the axis-2 gearbox

Continued

	Action	Note
2	Remove all but one of the remaining attachment screws that secure the lower arm to the axis-2 gearbox.	 <p data-bbox="940 656 1050 674">xx1400002182</p>

Removing and lifting away the lower and upper arms un-separated

Use this procedure to remove and lift away the lower and upper arm un-separated.

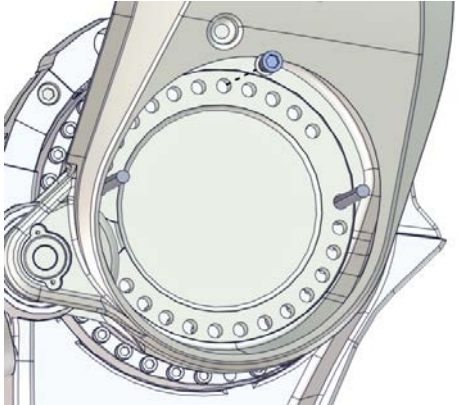
	Action	Note
1	Put two pallets on the floor, in front of the position of the mechanical stop.  Note Using the method to replace the gearbox with cable harness and DressPack fitted, is only a recommendation. If it is not possible to put the arm system close enough to the robot and keep the cable harness partly fitted, it is necessary to remove the cable harness and DressPack in base and frame first.	
2	 CAUTION The lower and upper arms together weigh 650 kg. All lifting accessories used must be sized accordingly!	
3	Remove the remaining screw and lift away the lower and upper arm together. Let the cabling run in the lower arm. Make sure not to stretch any cabling!  Note Two persons required. One person to operate the overhead crane and one person to handle the arm system.	 <p data-bbox="940 1888 1050 1906">xx170000442</p>

Continues on next page

	Action	Note
4	Use a piece of wood or similar as a support under the arm house when the arm system is put down on the pallets. This is done in order not to damage any parts of the cable harness and DressPack.	

Disconnecting the axis-2 motor cables

Use this procedure to disconnect the motor cables.

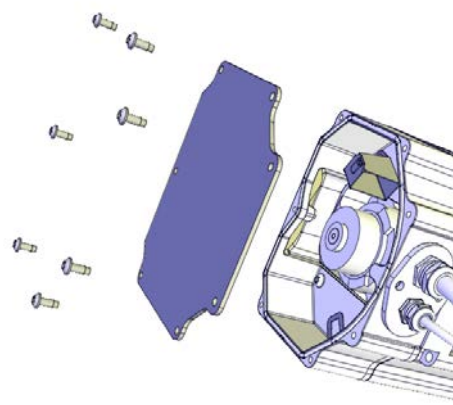
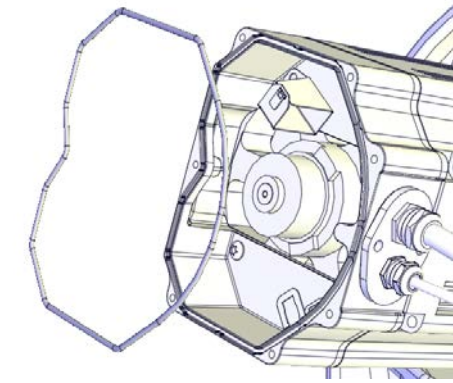

	Action	Note
1	 DANGER Make sure that all supplies for electrical power, hydraulic pressure, and air pressure are turned off.	
2	Unscrew the attachment screws and washers and remove the motor cover.	 <p>xx1200001135</p>
3	Make sure the o-ring is present.	 <p>xx1200001070</p>

Continues on next page

4 Repair

4.8.3 Replacing the axis-2 gearbox

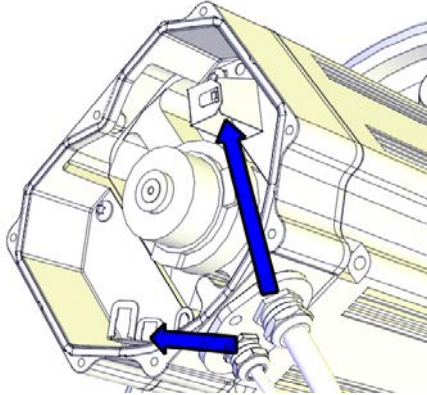

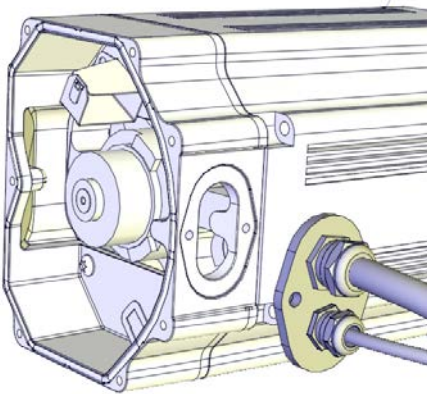

Continued

	Action	Note
4	Disconnect the motor cables.	 <p data-bbox="943 714 1050 734">xx1200001066</p>
5	Remove the cable gland cover. Make sure the gasket is not damaged.  Tip Make a note in which direction the cable gland hole is facing, if the motor will be removed too. The motor shall be refitted in the same position.	 <p data-bbox="943 1184 1050 1205">xx1200001067</p>
6	Use caution and pull out the motor cables.	

Removing the axis-2 motor

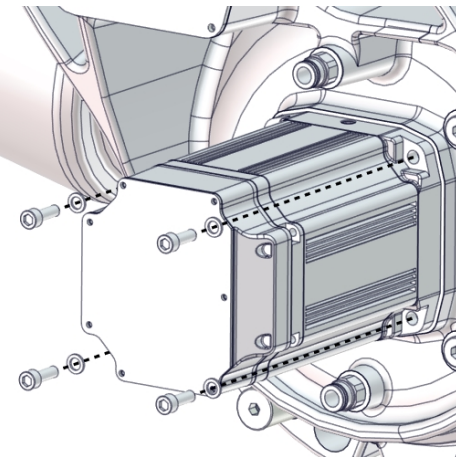
	Action	Note
1	Before removing the motor, make sure that the axis-2 gearbox is completely drained.	
2	To release the brake, connect the 24 VDC power supply. Connect to connector R2.MP2, axis-2 motor: <ul style="list-style-type: none"> • + = pin 2 • - = pin 5 	

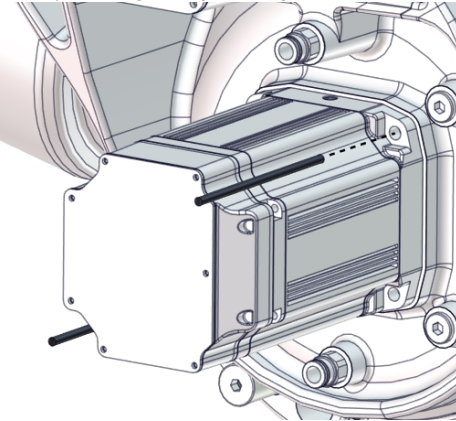
Continues on next page

	Action	Note
3	<p>Remove the attachment screws. Use a bits extender in order to reach the screws.</p>	<p>Bits extender: 3HAC12342-1</p>  <p>xx170000515</p>
4	<p>Fit guide pins in opposite holes.</p> <p> Tip</p> <p>Lubricate the guide pins with some grease to make the motor slide better.</p>	<p>Guide pin, M10x150: 3HAC15521-2 Always use guide pins in pairs.</p>  <p>xx170000516</p>
5	<p> CAUTION</p> <p>Whenever parting/mating motor and gearbox, the gears may be damaged if excessive force is used.</p>	
6	<p>If required, press the motor out of its position by using the removal tool in opposite holes of the motor.</p>	<p>Removal tool motor M12: 3HAC14631-1 Always use removal tools in pairs.</p>
7	<p>Disconnect the 24 VDC power supply.</p>	
8	<p> CAUTION</p> <p>The motor weighs 28 kg. All lifting accessories used must be sized accordingly.</p>	
9	<p>Carefully lift the motor out on the guide pins, in order to get the pinion away from the gear and let it rest on the guide pins.</p>	

Continues on next page

4 Repair

4.8.3 Replacing the axis-2 gearbox

Continued

	Action	Note
10	Fasten the lifting accessory. Attach the lifting chain to the accessory and an overhead crane.	Lifting accessory, motor: 3HAC15534-1 Lifting accessory (chain): 3HAC15556-1
11	Remove the motor by sliding it out on the guide pins and lift it off.	Make sure the pinion is not damaged.

Removing the axis-2 gearbox

Use the procedure to remove gearbox.

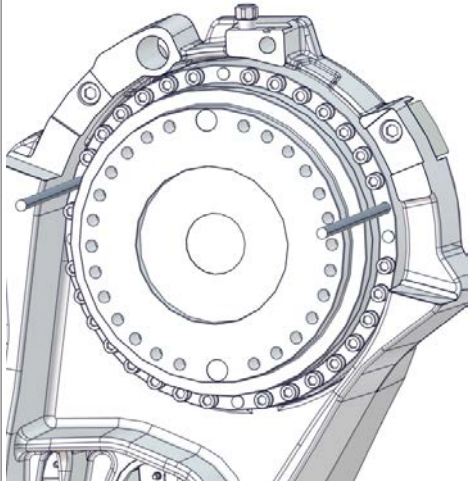
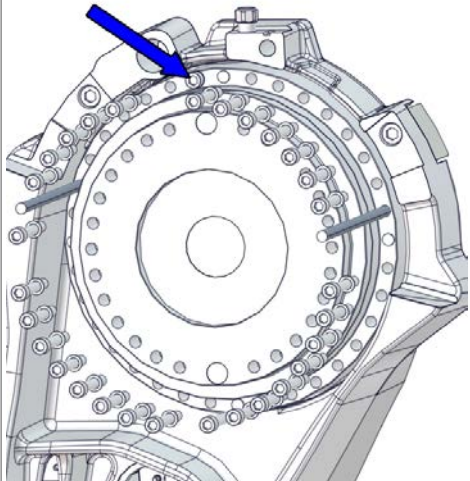
	Action	Note
1	<p>Remove two attachment screws in opposite holes and replace them with guide pins.</p> <p> Tip</p> <p>Lubricate the guide pins with some grease to make the gearbox slide better.</p>	<p>Guide pin, M12x150: 3HAC13056-2 Guide pin, M12x200: 3HAC13056-3 Always use guide pins in pairs.</p>  <p>xx170000443</p>
2	<p>Leave one of the upper attachment screws and remove the rest. The remaining screw is used to prevent the gearbox from falling down.</p>	 <p>xx170000444</p>

Continues on next page

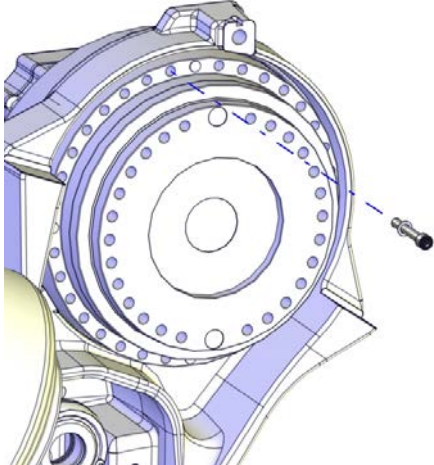
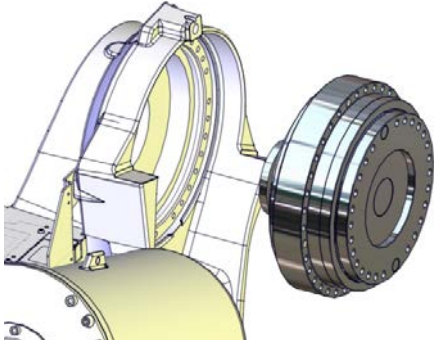
	Action	Note
3	 CAUTION The gearbox weighs 110 kg. All lifting accessories used must be sized accordingly!	
4	Remove the remaining screw left in the gearbox.	 <p>xx1400002185</p>
5	Use two fully threaded attachment screws (M12) as removal tools to press the gearbox out of position.	
6	Attach the lifting accessory to the gearbox.	Lifting accessory, gearbox: 3HAC046128-001
7	Let the gearbox slide out on the guide pins.	
8	Remove the gearbox.	 <p>xx1400002186</p>

Refitting the axis-2 gearbox

Use these procedures to refit the gearbox.

Continues on next page

4 Repair

4.8.3 Replacing the axis-2 gearbox

Continued

Follow the order of the separate procedures according to the order they are presented.



CAUTION



When performing these procedures, the cable harness will still be fitted or partly fitted to the robot. Use the utmost caution not to cause any damage to the cable harness!

Refitting the gearbox

Use this procedure to refit the gearbox.

	Action	Note
1	CAUTION The gearbox weighs according to variant 110 kg. All lifting accessories used must be sized accordingly!	
2	Apply the lifting accessory to the gearbox.	Lifting accessory, gearbox: 3HAC046128-001
3	Use caution and lift the gearbox so that it rests on its side.	
4	Remove the o-ring and wipe it clean. Note This must also be done on a new spare part!	
5	Wipe clean the contact surfaces from any contamination. Note Also wipe clean the o-ring groove.	
6	Check the condition of the o-ring. Replace if damaged.	
7	Lubricate the o-ring with some grease, for a better fitting in the groove.	
8	Fit the o-ring in the groove.	

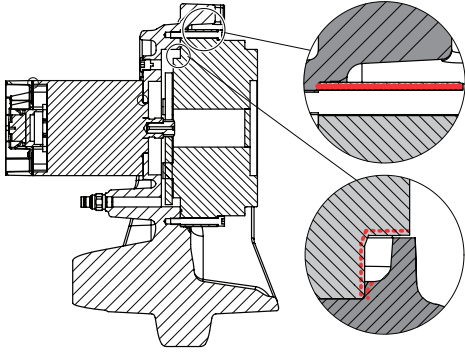
Continues on next page

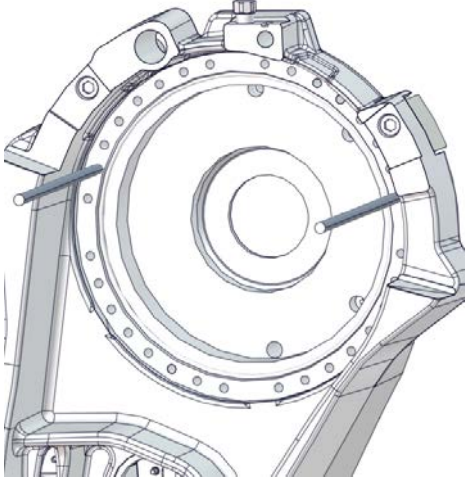
	Action	Note
9	<p><i>Foundry Plus:</i> Apply Mercasol on the surfaces shown in the figure.</p>	 <p>xx1400000374</p>
10	<p>Fit two guide pins in opposite holes (M12).</p> <p> Tip Lubricate the guide pins with some grease to make the gearbox slide better.</p>	<p>Guide pin, M12x150: 3HAC13056-2 Guide pin, M12x200: 3HAC13056-3 Always use guide pins in pairs.</p>  <p>xx1700000445</p>
11	Lift the gearbox and let it rest on the guide pins.	
12	Slide the gearbox into position.	

Continues on next page

4 Repair

4.8.3 Replacing the axis-2 gearbox

Continued

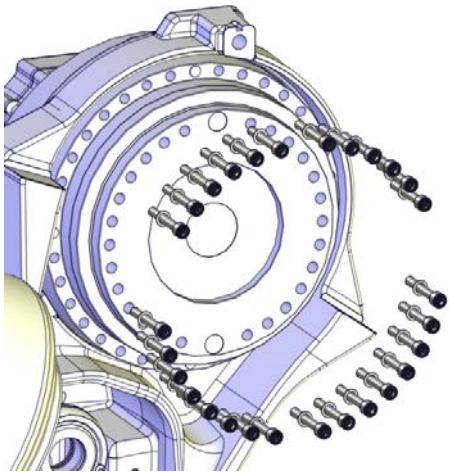

	Action	Note
13	Fit the attachment screws now accessible.	 <p data-bbox="940 792 1050 808">xx1400002188</p> <p data-bbox="940 831 1407 891">Screw dimension: M12x90. Screw quality: 12.9 Gleitmo (totally 32 pcs)</p>
14	Remove the lifting accessory.	
15	Remove the guide pins and fit the remaining attachment screws.	
16	Secure the gearbox with its attachment screws.	Tightening torque: 120 Nm.

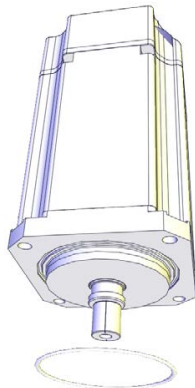
Preparations prior to refitting motor

	Action	Note
1	 <p data-bbox="571 1234 679 1263">DANGER</p> <p data-bbox="480 1294 1007 1375">Make sure that all supplies for electrical power, hydraulic pressure, and air pressure are turned off.</p>	
2	<p data-bbox="480 1413 1011 1487">Remove any old paint residues or other contamination from the contact surfaces on both the motor and the mating parts.</p> <p data-bbox="480 1496 999 1547">Wipe clean the contact surfaces and the o-ring groove.</p>	
3	Fit a new o-ring.	 <p data-bbox="1027 1984 1137 2000">xx1200001019</p>

Continues on next page

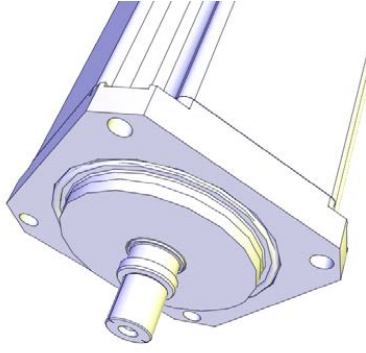
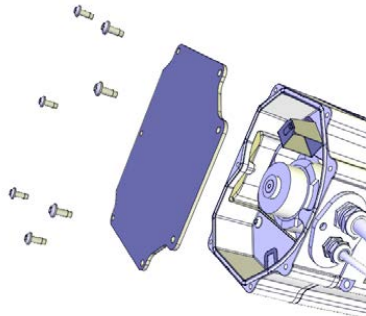
4.8.3 Replacing the axis-2 gearbox
Continued

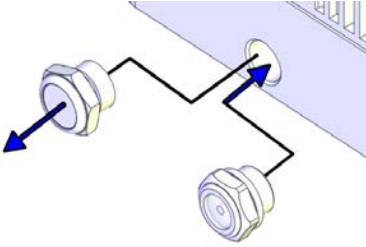
	Action	Note
4	<p>Make sure the o-ring is seated in the groove.</p> <p> Tip</p> <p>Lubricate the o-ring with some grease for a better fitting in the groove.</p>	 <p>xx1200001020</p>
5	<p>If the motor is a new spare part, remove the cover.</p>	 <p>xx1200001135</p>
6	<p><i>Protection type Foundry Plus</i></p> <p>Valid for axis-2, axis-3, axis-4 and axis-6 motors.</p> <p>If the motor is a new spare part, the evacuation hole protection filter must be replaced with a transparent plug/sight glass (enclosed with the spare part delivery). Remove the protection filter and install the transparent plug/sight glass.</p> <p>On the axis-6 motor there are two protection filters that must be replaced with transparent plugs/sight glasses.</p> <div style="display: flex; justify-content: space-around;"> <div data-bbox="513 1464 788 1688">  <p>xx2200002188</p> <p>Transparent plug (Foundry Plus).</p> </div> <div data-bbox="794 1464 1043 1688">  <p>xx1800000101</p> <p>Protection filter (Standard).</p> </div> </div>	<p>Tightening torque, transparent plug: 20 Nm \pm10%</p> <p>Tightening torque, protection filter: 10 Nm \pm10%</p>  <p>xx1600000576</p>

Securing the axis-2 motor





	Action	Note
1	Fit guide pins in opposite holes.	<p>Guide pin, M10x150: 3HAC15521-2</p> <p>Always use guide pins in pairs.</p>

Continues on next page

4 Repair

4.8.3 Replacing the axis-2 gearbox

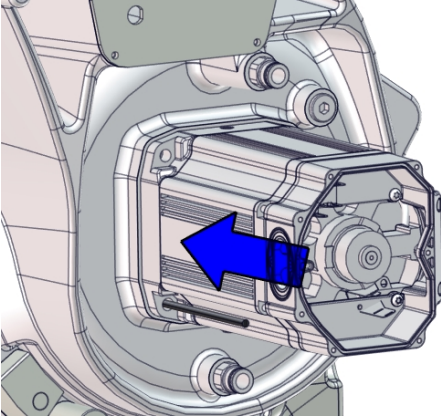
Continued

	Action	Note
2	<p> CAUTION</p> <p>The motor weighs 28 kg. All lifting accessories used must be sized accordingly.</p>	
3	Apply the lifting accessory.	Lifting accessory, motor: 3HAC15534-1 Lifting accessory (chain): 3HAC15556-1
4	<p> Note</p> <p>Make sure the cable gland opening is turned the correct way.</p>	 <p>xx170000517</p>
5	Lift the motor and put it on the guide pins as close as possible to its final position without pushing the motor pinion into the gear.	
6	Remove the lifting accessory and allow the motor to rest on the guide pins.	
7	Apply the rotation tool and use it to rotate the pinion when mating it into the gear.	Rotation tool: 3HAB7887-1
8	<p>To release the brakes, connect the 24 VDC power supply.</p> <p>Connect to connector R2.MP2, axis-2 motor:</p> <ul style="list-style-type: none"> • + = pin 2 • - = pin 5 	
9	<p> CAUTION</p> <p>Whenever parting/mating motor and gearbox, the gears may be damaged if excessive force is used.</p>	
10	<p>Use caution and fit the motor in its final position while at the same time rotating the motor pinion slightly using the rotation tool.</p> <ul style="list-style-type: none"> • Make sure that the motor pinion is properly mated to the gear of the gearbox. • Make sure that the motor pinion does not get damaged. • Make sure that the direction of the cable exit is facing the correct way. 	

Continues on next page

4.8.3 Replacing the axis-2 gearbox Continued

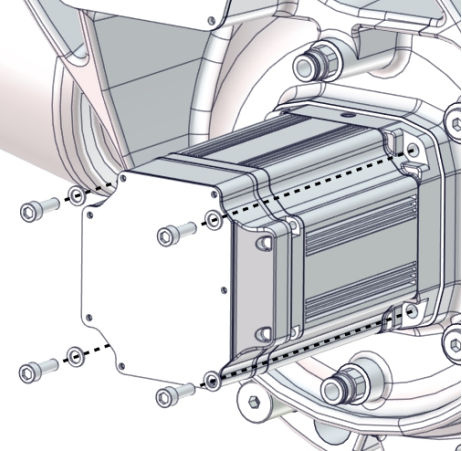
	Action	Note
11	Fit two of the attachment screws and washers.	Screws: M10x40 quality 12.9 Gleitmo
12	Remove the guide pins and replace with the remaining attachment screws.	
13	Secure the motor with its attachment screws and washers. Use a bits extender in order to reach the screws.	Bits extender: 3HAC12342-1 Tightening torque: 50 Nm. Screw dimension: M10x40 quality 12.9 Gleitmo (4 pcs)  xx1700000515
14	Perform a leak-down test.	See Performing a leak-down test on page 188 .

Lifting back and refitting the lower and upper arm

Use this procedure to lift back and refit the lower and upper arm un-separated.

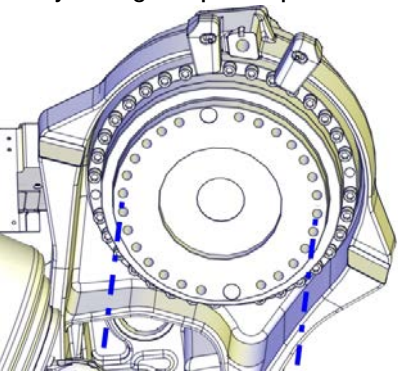



	Action	Note
1	Connect the 24 VDC power supply to the axis-2 motor to release the brakes of the motor.	
2	Fit the rotation tool, if not already fitted.	Rotation tool: 3HAB7887-1
3	Fit two guide pins in opposite holes in the axis-2 gearbox.  Tip Lubricate the guide pins with some grease to make the lower arm slide better.	Guide pin, M16x150: 3HAC13120-2 Always use guide pins in pairs.  xx1400002189

Continues on next page

4 Repair

4.8.3 Replacing the axis-2 gearbox

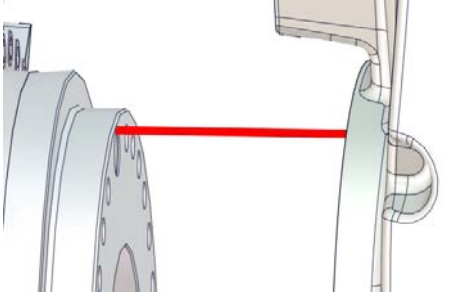
Continued

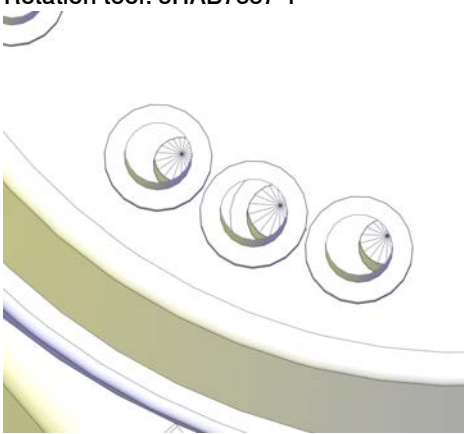
	Action	Note
4	<p> CAUTION</p> <p>The lower and upper arms together weigh 650 kg. All lifting accessories used must be sized accordingly!</p>	
5	Apply the lifting accessories, if not already fitted.	
6	<p>Lift the lower and upper arm.</p> <p>Make sure:</p> <ul style="list-style-type: none"> • not to stretch any of the cables • that the arm package is level when lifted. 	
7	<p>Align the lower arm with the gearbox in height. Match the upper edge of the gearbox with the corresponding edge inside the lower arm cavity.</p> <p> Tip</p> <p>This operation is best performed by two persons working together.</p>	 <p>xx170000692</p>
8	<p>Rotate the gear to match the hole pattern in the lower arm, using the rotation tool.</p> <p> Note</p> <p>Some of the screw holes in the gear are unused.</p>	<p>Rotation tool: 3HAB7887-1</p>  <p>xx130000819</p>
9	Slide the lower arm onto the guide pins, when the hole pattern is matched and in the correct position for all screws.	
10	Slide the lower arm on to the guide pins.	
11	<p>Use caution and move the arms into position at the axis-2 gearbox on the guide pins.</p> <p>Rotate the axis-2 gearbox until the hole pattern is matching the holes in the lower arm.</p>	

Continues on next page

4.8.3 Replacing the axis-2 gearbox
Continued

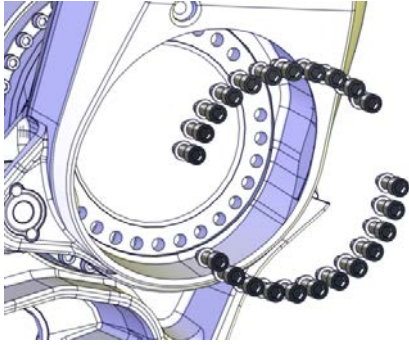
	Action	Note
12	Fit one attachment screw in one of the upper holes using it for security and lower the lifting accessory a little.	
13	Fit all now accessible attachment screws.	 <p data-bbox="970 757 1082 772">xx1400002190</p>
14	Remove the two guide pins and fit the remaining attachment screws.	
15	Secure the lower arm to the axis-2 gearbox with its attachment screws.	Tightening torque M16: 300 Nm.
16	Disconnect the 24 VDC power supply.	
17	Remove the lifting accessories.	

Connecting the axis-2 motor cables

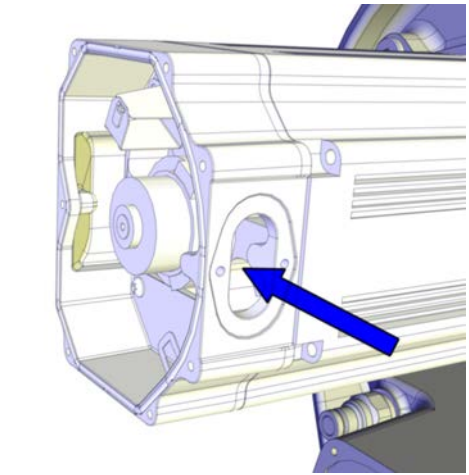

	Action	Note
1	Push the motor cables through the cable gland opening.	 <p data-bbox="970 1630 1082 1646">xx1300000738</p>

Continues on next page



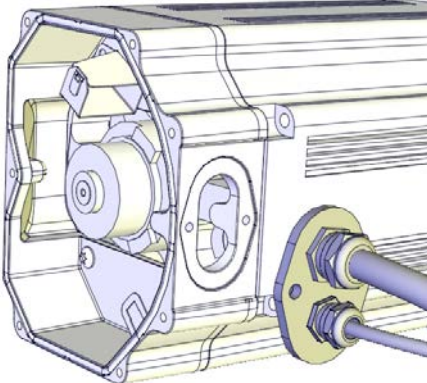
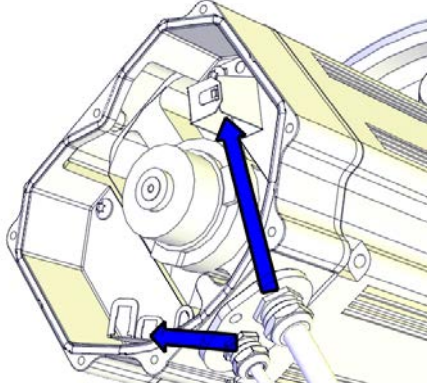

4 Repair

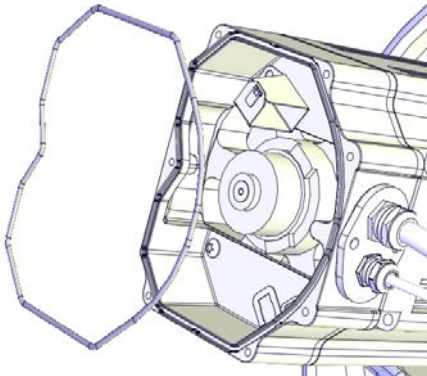
4.8.3 Replacing the axis-2 gearbox

Continued

	Action	Note
2	<p>Refit the cable gland cover.</p> <p> Note Replace the gasket if damaged.</p>	 <p>xx1200001067</p>
3	<p>Connect the motor cables.</p> <p>Connect in accordance with the markings on the connectors.</p>	 <p>xx1200001066</p>
4	<p>Inspect the o-ring.</p> <p> Note Replace if damaged.</p>	<p>O-ring, axis-1: 3HAC054692-002 O-ring, axis-2: 3HAC054692-002 O-ring, axis-3: 3HAC054692-002 O-ring, axis-4: 3HAC054692-001</p>  <p>xx1200001070</p>
5	<p>Wipe clean o-ring and o-ring groove.</p>	

Continues on next page

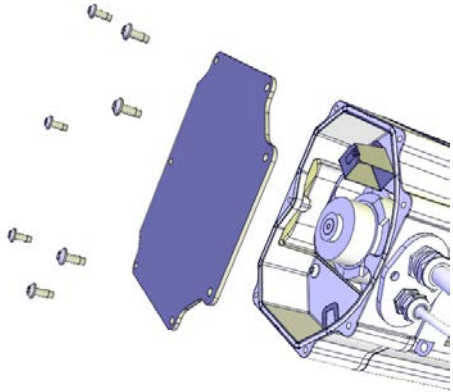
	Action	Note
6	Refit the o-ring.  Tip Lubricate the o-ring with some grease for a better fitting in the groove.	
7	 CAUTION When fitting the motor cover, make sure that none of the cables inside will be damaged.	
8	Refit the motor cover with it's attachment screws.  Note Do not reuse the self-threading attachment screws. Replace with standard attachment screws or the threads will be damaged.  Note Make sure the o-ring is undamaged and properly fitted.	Attachment screws: M5x12 8.8 (7 pcs)  xx1200001135
9	Make sure that the covers are tightly sealed.	

Refitting the cabling

Use this procedure to refit the cabling.



	Action	Note
1	Use caution and push the cable harness into the lower arm.	

Continues on next page

4 Repair



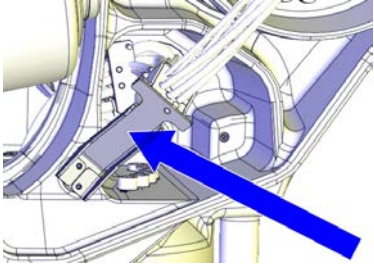
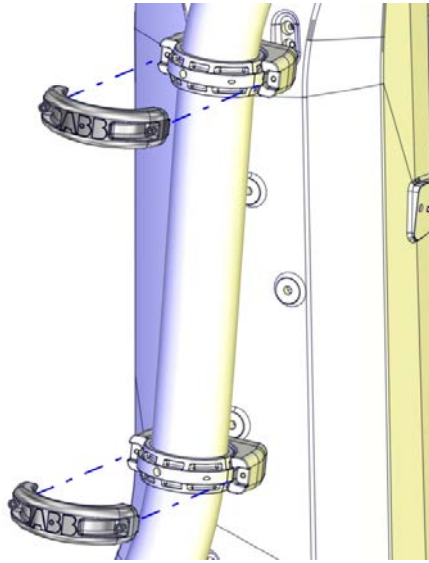

4.8.3 Replacing the axis-2 gearbox

Continued

	Action	Note
2	<p>Refit the <i>axis-2 lower arm metal clamp</i> and the <i>axis-3 lower arm metal clamp</i> located on the inside of the lower arm.</p> <p> Note</p> <p>The screws are reached from the outside of the lower arm!</p>	 <p>xx1200001282</p>
3	Refit the cable bracket on the frame.	 <p>xx1200001283</p>
4	<p>If robot is equipped with DressPack.</p> <ul style="list-style-type: none">Place the cabling in the two ball joint housings on the lower arm and close the ball joint housings.	<p>How to refit the DressPack is described in the product manual "IRB 6700 DressPack". For article number see References on page 10.</p>  <p>xx1400000195</p>

Continues on next page

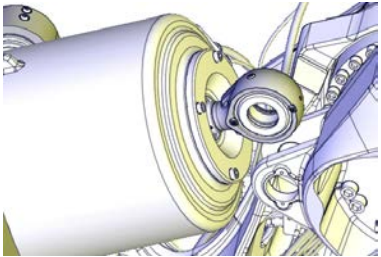
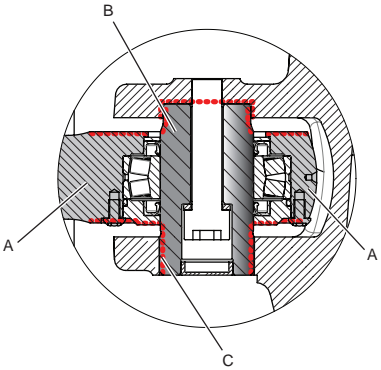
Refitting the front shaft

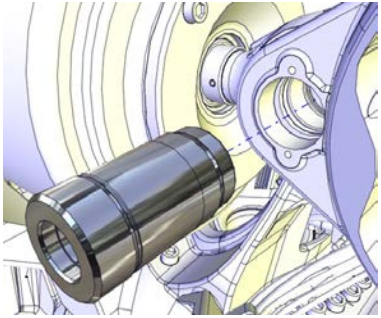

	Action	Note
1	<p> DANGER</p> <p>Turn off all:</p> <ul style="list-style-type: none"> • electric power supply • hydraulic pressure supply • air pressure supply <p>to the robot, before entering the safeguarded space.</p>	
2	Remove all residues of Loctite in the screw hole of the shaft.	
3	Wipe all contact surfaces inside the recess clean from residual grease or other contamination.	
4	<p>Align the balancing device link ear with the hole in the lower arm.</p> <p> Note</p> <p>Verify that the link ear is correctly turned.</p>	 <p>xx1300000784</p>
5	<p><i>Foundry Plus:</i></p> <p>Apply Mercasol on the surfaces on the shaft and front ear.</p>	 <p>xx1400000368</p> <p>A Front link ear B Shaft C Mercasol (red dotted lines)</p>
6	<p>Lubricate the shaft and place it to the front ear.</p> <p> Note</p> <p><i>Foundry Plus:</i></p> <p>Do not lubricate surfaces where Mercasol is applied.</p>	 <p>xx1200001280</p>

Continues on next page

4 Repair

4.8.3 Replacing the axis-2 gearbox

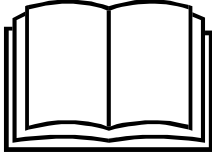
Continued

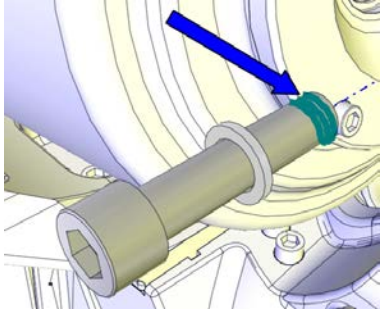
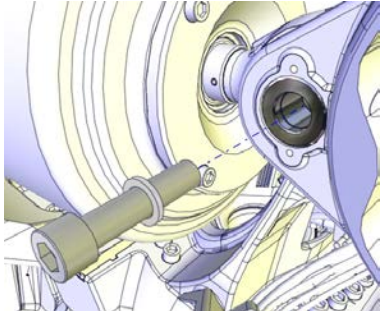
	Action	Note
7	<p>Press in the shaft using the dismantle and mounting tool, according to user instructions enclosed with the equipment.</p>  <p>xx0900000813</p> <p>Go to the user instructions enclosed with the press tool.</p> <p> DANGER</p> <p>Handling the tool incorrectly will cause serious injury. Read and follow enclosed user instructions for the tool.</p>	<p>Dismantle and mounting tool set: 3HAC028920-001 User instructions are enclosed with the tool.</p>
8	<p>Apply locking liquid on the first threads of the screw.</p>	<p>Loctite 2701</p>  <p>xx1300000782</p>
9	<p>Secure the shaft with screw and washer.</p>	<p>Tightening torque: 180 Nm</p>  <p>xx1200001279</p>

Continues on next page

4.8.3 Replacing the axis-2 gearbox
Continued

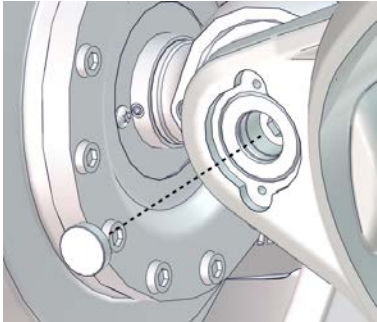
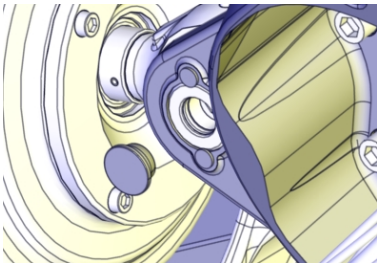
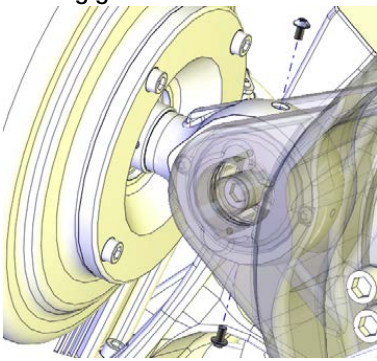
	Action	Note
10	Fit the protection plug or a new VK-cover (depends on shaft version).	 <p>xx170000088</p>  <p>xx1900002311</p>
11	Unscrew both screws in link ear. Fill the bearing with grease from the upper hole, until the grease appears in the lower hole.	<p>Bearing grease: 3HAC042536-001</p>  <p>xx1300000783</p>
12	Refit the two screws and wipe clean from residual grease.	
13	Refit the DressPack bracket, if used.	

Performing fine calibration on axis 2

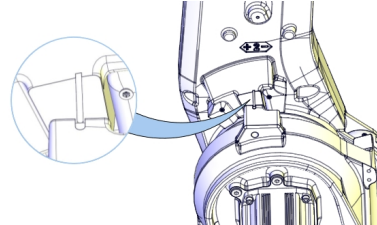
	Action	Note
1	Jog axis 2 to synchronization position by aligning the synchronization marks on axis 2.	 <p>xx1300000869</p>

Continues on next page





4 Repair

4.8.3 Replacing the axis-2 gearbox

Continued

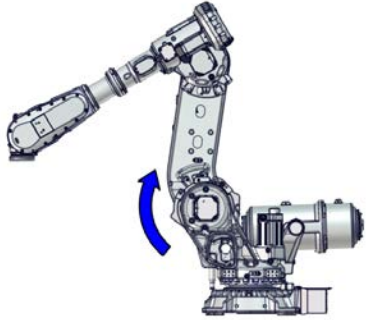
	Action	Note
2	Run the fine calibration routine on axis 2 to create a new approximate zero position. This is needed for positioning the axis according to given axis degrees further on.	

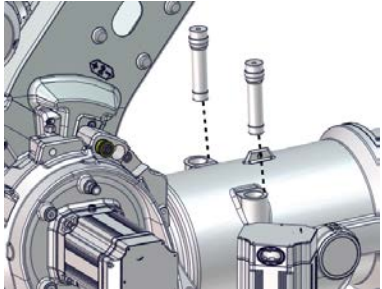

Restoring the balancing device

	Action	Note
1	Remove the lifting equipment from the balancing device.	
2	Jog axis 2 to -4° to be able to remove the relief screws.	 xx1700001406
3	Remove the relief screws to activate the balancing device.  Note Axis 2 must be in -4° .	 xx1700000070
4	Refit the covers. Make sure that the o-rings are still fitted.  Note Only manual force is required, no tightening torque.	 xx1700000451

Continues on next page

Securing the lower arm

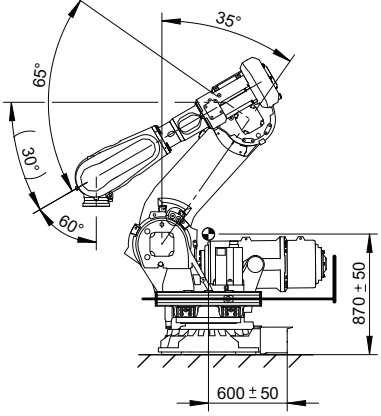
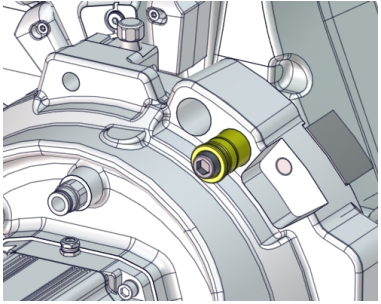
Use this procedure to secure the lower arm before lifting the robot to inverted position.

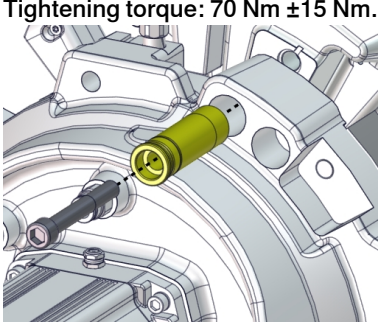
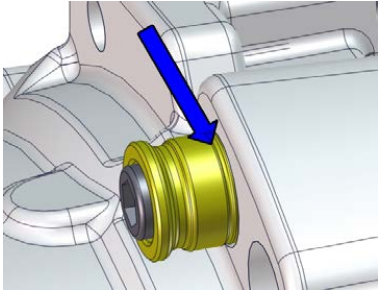
	Action	Note
1	<p>Verify that the robot stands in position:</p> <ul style="list-style-type: none"> • Axis 1: 0° • Axis 2: -35° • Axis 3: +65° • Axis 4: 0° • Axis 5: +60° • Axis 6: no significance 	 <p>xx1600001371</p>
2	<p>Remove the transportation lock screw and the yellow sleeve from the parking position.</p>	 <p>xx1700000348</p>
3	<p>Insert the yellow sleeve and the transportation lock screw in the hole at the locking position. Insert the sleeve all the way so that the marking in the sleeve is aligned with the casting, see figure. Tighten the screw.</p> <p> DANGER</p> <p>Always use the transportation lock screw and sleeve to lock the lower arm at transportation, turning and floor standing.</p>	<p>Tightening torque: 70 Nm ±15 Nm.</p>  <p>xx1700000347</p>  <p>xx1600002114</p>

Continues on next page

4 Repair

4.8.3 Replacing the axis-2 gearbox

Continued

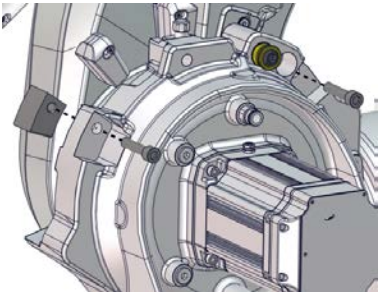
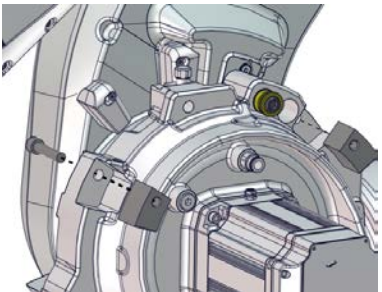

Preparations before lifting up the robot to inverted position

	Action	Note
1	Remove the two service stops from maintenance position, if previously moved there.	 xx170000068
2	Fit the service stops in their parking position.	 xx170000067
3	Fasten the fork lift accessory.	See user instructions enclosed with the fork lift accessory. Fork lift accessory set: 3HAC058825-001.
4	Remove the bolts securing the robot to the foundation.	

Orienting and securing the robot

	Action	Note
1	Lift the robot using the fork lift accessory.	See user instructions enclosed with the fork lift accessory.
2	Move the robot close to its installation location.	
3	Rotate the robot into inverted position using the turning tool or using a fork lift truck with a rotator attachment.  DANGER Make sure that there is enough space underneath the robot. See user instructions for the turning tool.	See user instructions enclosed with the turning tool.
4	Guide the robot using two M24 screws while lifting it into its mounting position.	

Continues on next page

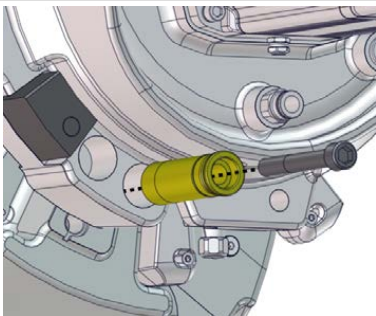
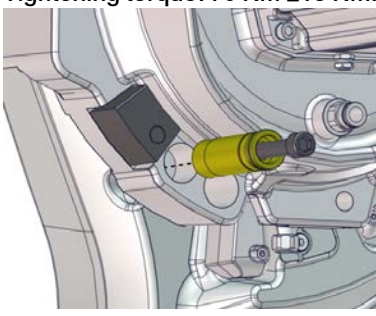
	Action	Note
5	<p>Fit the bolts and washers in the base attachment holes.</p> <p> Note Lightly lubricate screws before assembly.</p> <p> CAUTION If high stress on screws are suspected, replace used screws with new ones.</p>	<p>Suitable screws, lightly lubricated: M24x100 (8 pcs), 8.8. Suitable washer: 4 mm flat washer. Screw tightening yield point utilization factor (v) (according to VDI2230): 90% (v=0.9). Tightening torque: 550 Nm (screws lubricated with Molykote 1000) 600-725 Nm, typical 650 Nm (screws none or lightly lubricated)</p>
6	Tighten bolts in a crosswise pattern to ensure that the base is not distorted.	
7	Remove the yellow sleeve and transportation lock screw from the transportation and turning position.	 <p>xx1700000269</p>
8	Fasten the yellow sleeve and transportation lock screw in its parking position.	<p>Tightening torque: 70 Nm ±15 Nm.</p>  <p>xx1700000270</p>

Concluding procedure

	Action	Note
1	If the robot is equipped with DressPack, refit the brackets of the ball joint housings on the wrist.	
2	Refill oil to the axis-2 gearbox.	See Filling oil into the axis-2 gearbox on page 160 .
3	Re-calibrate the robot.	Axis Calibration is described in Calibrating with Axis Calibration method on page 694 . General calibration information is included in section Calibration on page 683 .

Continues on next page

4 Repair

4.8.3 Replacing the axis-2 gearbox

Continued

	Action	Note
4	 DANGER Make sure all safety requirements are met when performing the first test run. See Test run after installation, maintenance, or repair on page 97 .	

4.8.4 Replacing the axis-3 gearbox

Location of the axis-3 gearbox

The axis-3 gearbox is located as shown in the figure.

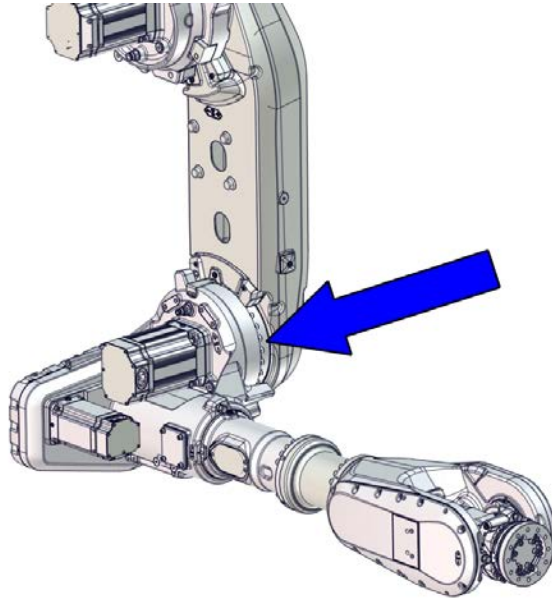

xx170000372

Summary of the replacement procedure

This is a brief summary of the replacement procedure, containing the major actions to be performed.

- 1 Remove the upper arm from the robot.

The upper arm cabling can stay fitted, if the distance between the axis-3 rotation centre and the floor does not exceed 2.1 m. If the distance exceeds 2.1 m, the cabling in the upper arm and the wrist must be removed.

Removal of the cabling in the upper arm and wrist is detailed in the procedures found in [Removing the cable harness - upper arm and wrist on page 220](#).

- 2 Replace the axis-3 gearbox.

Spare parts

Spare parts	Spare part number	Note
Axis-3 gearbox	See <i>Product manual, spare parts - IRB 6700/IRB 6700Inv.</i>	

Required tools and equipment

Equipment, etc.	Article number	Note
Lifting shackle, 2 pcs	-	SA-10-8-NA1

Continues on next page

4 Repair

4.8.4 Replacing the axis-3 gearbox

Continued

Equipment, etc.	Article number	Note
Oil collecting vessel	-	The capacity of the vessel must be sufficient to take the complete amount of oil.
Oil dispenser	-	One example of oil dispenser can be found in section Type of lubrication in gearboxes on page 147 .
Lifting eye, M16	3HAC14457-4	
Lifting eye, M12	3HAC16131-1	
Lifting eye, M12	3HAC16131-1	
Bits extender	3HAC12342-1	300 mm, bits 1/2"
Fender washer	-	Outer diameter: minimum 26 mm, maximum 30 mm, hole diameter: 13 mm, thickness: 3 mm.
Roundsling, 1.5 m	-	Lifting capacity: 2,000 kg.
Roundsling, 2 m	-	Lifting capacity: 2,000 kg.
Roundsling, 2 m	-	Lifting capacity: 2,000 kg.
Pallet		Used for putting down removed parts from robot.
Lifting accessory, gearbox	3HAC046112-001	
Removal tool motor M12	3HAC14631-1	Used to push out the motor, if necessary. Always use removal tools in pairs.
ScrewsM8x75, fully threaded	-	Used to push out the gearbox, if necessary.
Guide pin, M12x150	3HAC13056-2	Always use guide pins in pairs.
Guide pin, M16x150	3HAC13120-2	Always use guide pins in pairs.
Guide pin, M16x200	3HAC13120-3	Always use guide pins in pairs.
Pinion	3HAC067545-001	Used for rotating the axis-3 gearbox when refitting upper arm.
24 VDC power supply	-	Used to release the motor brakes.
Leak-down tester	-	
Calibration tool box, Axis Calibration	3HAC055412-001	Delivered as a set of calibration tools.
Standard toolkit	-	Content is defined in section Standard toolkit on page 724 .

Consumables

Equipment, etc	Article number	Note
Grease	3HAC042536-001	Shell Gadus S2 Used to lubricate o-rings.
O-ring	3HAB3772-107	D=102x3 Used on motor flange.
O-ring	3HAC054692-002	D=169.5x3 Used on motor cover.

Continues on next page

Equipment, etc	Article number	Note
O-ring	3HAB3772-145	D=266.29x3.53 Used on gearbox.

Deciding calibration routine

Decide which calibration routine to be used, based on the information in the table. Depending on which routine is chosen, action might be required prior to beginning the repair work of the robot, see the table.

	Action	Note
1	<p>Decide which calibration routine to use for calibrating the robot.</p> <ul style="list-style-type: none"> Reference calibration. External cable packages (DressPack) and tools can stay fitted on the robot. Fine calibration. All external cable packages (DressPack) and tools must be removed from the robot. 	
	<p>If the robot is to be calibrated with reference calibration:</p> <p>Find previous reference values for the axis or create new reference values. These values are to be used after the repair procedure is completed, for calibration of the robot.</p> <p>If no previous reference values exist, and no new reference values can be created, then reference calibration is not possible.</p>	<p>Follow the instructions given in the reference calibration routine on the FlexPendant to create reference values.</p> <p>Creating new values requires possibility to move the robot.</p> <p>Read more about reference calibration for Axis Calibration in Reference calibration routine on page 695.</p>
	<p>If the robot is to be calibrated with fine calibration:</p> <p>Remove all external cable packages (DressPack) and tools from the robot.</p>	

Removing the axis-3 gearbox

Use these procedures to remove the axis-3 gearbox.

Preparations before removing the axis-3 gearbox

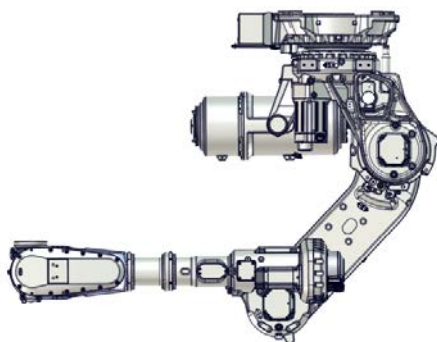

	Action	Note
1	Decide which calibration routine to use, and take actions accordingly prior to beginning the repair procedure.	
2	<p>Jog the robot to the position:</p> <ul style="list-style-type: none"> Axis-1: a position that allows best possible access to fit the lifting accessories to the upper arm. Axis-2: -35 Axis-3: -143 (so that the upper arm is horizontal) Axis-4: 0° Axis-5: -90° Axis-6: 0° 	 <p>xx1700000450</p>

Continues on next page

4 Repair

4.8.4 Replacing the axis-3 gearbox

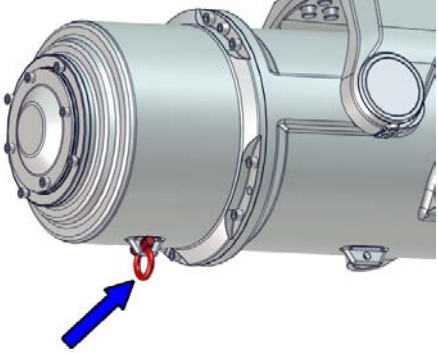
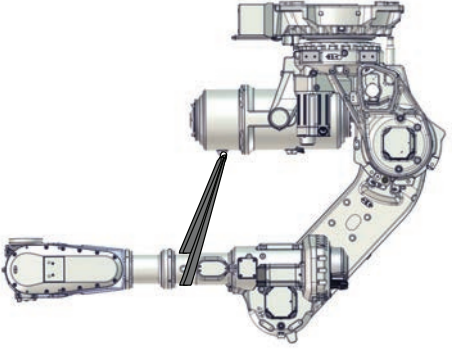

Continued

Action	Note
<p>3</p> <p> DANGER</p> <p>Turn off all:</p> <ul style="list-style-type: none"> • electric power supply • hydraulic pressure supply • air pressure supply <p>to the robot, before entering the safe-guarded space.</p>	
<p>4</p> <p>Begin draining the gearbox.</p>	<p>See Draining the axis-3 gearbox on page 163.</p>
<p>5</p> <p>Fasten a lifting shackle on the balancing device.</p>	<p>SA-10-8-NA1 (1 pcs)</p>  <p>xx180000044</p>
<p>6</p> <p>Run a lifting sling around the upper arm and fasten to the balancing device shackle.</p>	<p>Roundsling, 1.5 m, Lifting capacity: 2,000 kg. (1 pcs)</p>  <p>xx180000043</p>
<p>7</p> <p> DANGER</p> <p>When releasing the holding brakes of the motor, the upper arm will be movable and may fall down if not secured. Verify that the upper arm is secured as previously described, before continuing.</p>	
<p>8</p> <p>Release the holding brakes for the axis-3 motor to give the weight of the upper arm to the roundsling attached to the balancing device.</p>	

Continues on next page

Securing the lower arm

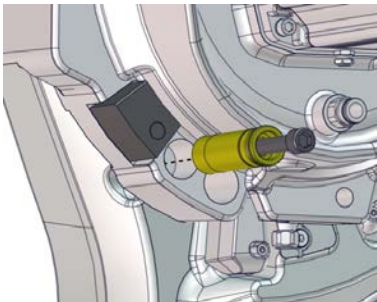
Use this procedure to secure the lower arm.

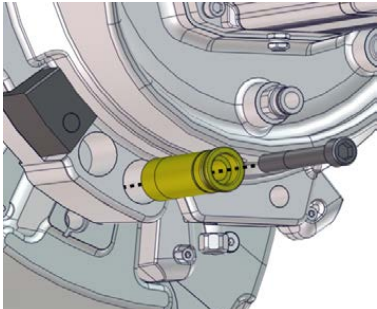
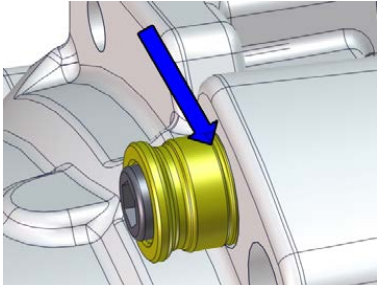
	Action	Note
1	Jog axis 2 to -35°.	
2	Remove the transportation lock screw and the yellow sleeve from the parking position.	 <p>xx1700000270</p>
3	<p>Insert the yellow sleeve and the transportation lock screw in the hole at the locking position. Insert the sleeve all the way so that the marking in the sleeve is aligned with the casting, see figure. Tighten the screw.</p> <p> DANGER</p> <p>Always use the transportation lock screw and sleeve to lock the lower arm at transportation, turning and floor standing.</p>	<p>Tightening torque: 70 Nm ±15 Nm.</p>  <p>xx1700000269</p>  <p>xx1600002114</p>

Removing the axis-3 motor





	Action	Note
1	Before removing the motor, make sure that the axis-3 gearbox is completely drained.	
2	<p> DANGER</p> <p>When releasing the holding brakes of the motor, the upper arm will be movable and may fall down if not secured. Verify that the upper arm is secured as previously described, before continuing.</p>	

Continues on next page

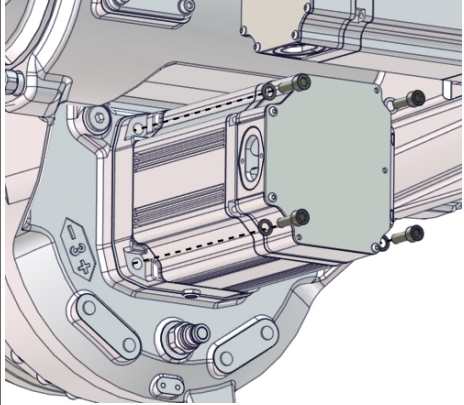

4 Repair

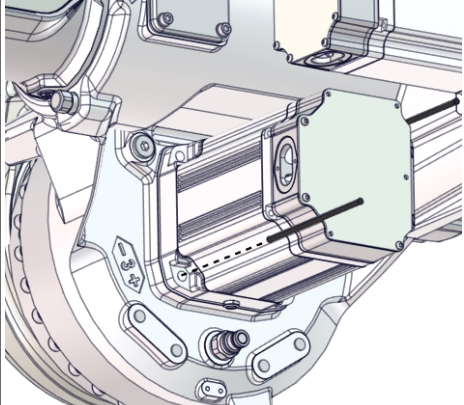
4.8.4 Replacing the axis-3 gearbox

Continued

	Action	Note
3	To release the brakes, connect the 24 VDC power supply. Connect to connector R2.MP3: <ul style="list-style-type: none"> • + = pin 2 • - = pin 5 	
4	Unscrew the attachment screws that hold the motor. Use a bits extender to reach the screws.	Bits extender: 3HAC12342-1  <small>xx1700000285</small>
5	Fit guide pins in opposite holes.  Tip Lubricate the guide pins with some grease to make the motor slide better.	Guide pin, M10x150: 3HAC15521-2 Always use guide pins in pairs.  <small>xx1700000346</small>
6	 CAUTION Whenever parting/mating motor and gearbox, the gears may be damaged if excessive force is used.	
7	If required, press the motor out of position by using the removal tool in the remaining holes for the motor.	Removal tool motor M12: 3HAC14631-1 Always use removal tools in pairs.
8	Use caution and lift the motor out on the guide pins, in order to get the pinion away from the gear, and let the motor rest on the guide pins.	

Continues on next page

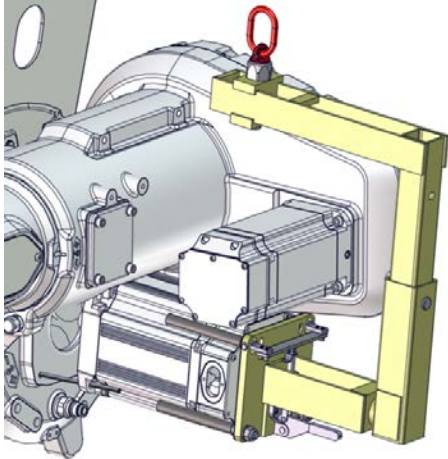
	Action	Note
9	 CAUTION The motor weighs 26 kg. All lifting accessories used must be sized accordingly.	
10	Fasten the lifting accessory to the motor. Attach the lifting chain to the accessory and an overhead crane.	Lifting accessory, motor: 3HAC15534-1 Lifting accessory (chain): 3HAC15556-1
11	When the motor is hanging in the lifting accessory, and the pinion no longer is mated to the gear, let the outer end of the motor hang lower so that it will hang in an angle. This position makes it easier to remove the axis-3 motor with the axis-4 motor still fitted.  CAUTION The pinion must have been parted from the gear before the motor is angled. If not there is a risk of damaging the pinion and gear.	 xx1700000271
12	Disconnect the 24 VDC power supply.	
13	Remove the motor by lifting it straight out.	Make sure the pinion is not damaged.

Removing the cable harness from the upper arm and wrist

The upper arm cabling can stay fitted, if the distance between the axis-3 rotation centre and the floor does not exceed 2.1 m. If the distance exceeds 2.1 m, the cabling in the upper arm and the wrist must be removed.

Removal of the cabling in the upper arm and wrist is described in [Removing the cable harness - upper arm and wrist on page 220](#).

Attaching the lifting accessories to the upper arm

Use this procedure to attach the lifting accessories to the upper arm.





	Action	Note
1	 CAUTION The weight of the complete upper arm (including the wrist) is 465 kg All lifting accessories used must be sized accordingly.	

Continues on next page

4 Repair

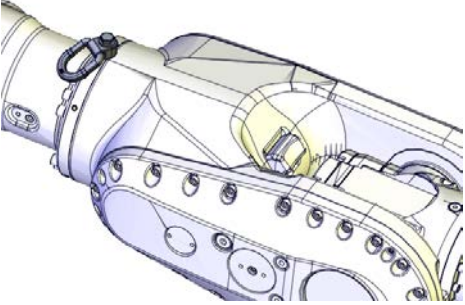
4.8.4 Replacing the axis-3 gearbox

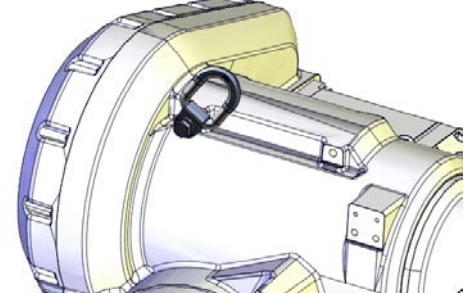
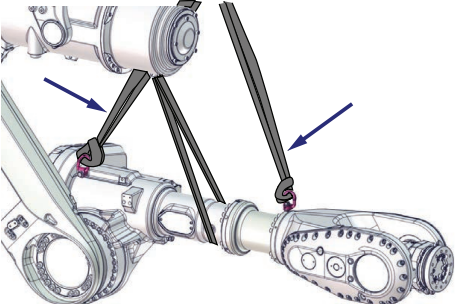

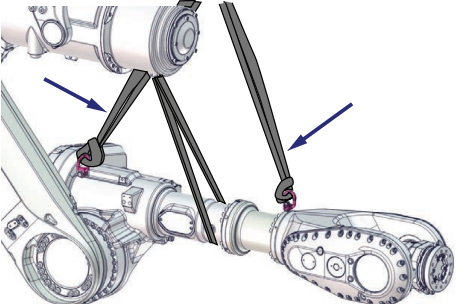
Continued

	Action	Note
2	Fit a lifting eye to the wrist.	Lifting eye, M12: 3HAC16131-1  <small>xx1200001133</small>
3	Fit a lifting eye in the arm house, with a fender washer underneath.  <small>xx1400002196</small>	Lifting eye, M12: 3HAC16131-1 Fender washer: Outer diameter: minimum 26 mm, maximum 30 mm, hole diameter: 13 mm, thickness: 3 mm.  <small>xx1200001134</small>
4	Attach a lifting sling to an overhead crane (or similar) and then to the lifting eye in the arm house.	Roundsling, 2 m: Lifting capacity: 2,000 kg. (2 pcs)  <small>xx1700000693</small>
5	Attach a lifting sling to an overhead crane (or similar) and then to the lifting eye in the wrist.  Note Lifting slings are used instead of lifting chains to not damage the balancing device surface.	 <small>xx1700000693</small>
6	Raise the lifting accessories to take the weight of the upper arm.	

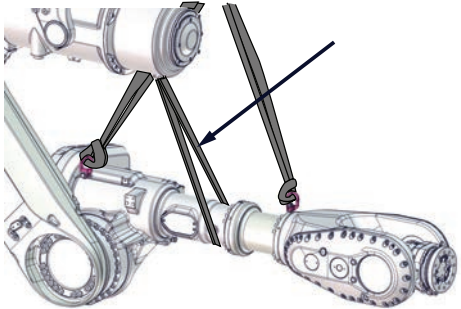
Continues on next page

	Action	Note
7	Remove the lifting sling between the upper arm and the balancing device.	 <p>xx180000047</p>

Preparations before removing the upper arm

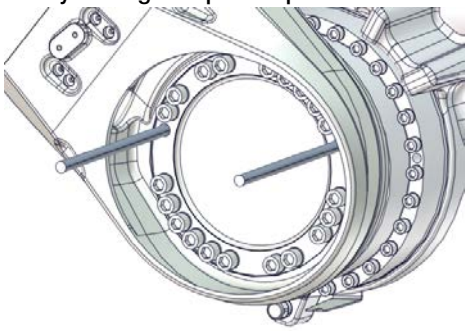
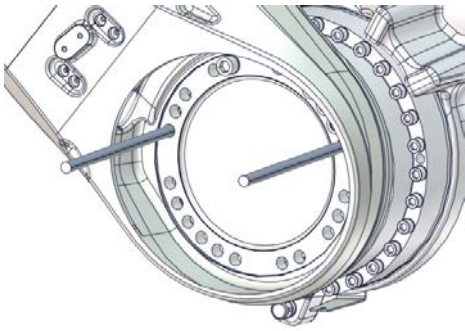
	Action	Note
1	<p>Remove two attachment screws in opposite holes and replace them with guide pins.</p> <p> Note</p> <p>Make sure that it is the screws that hold the lower arm to the axis-3 gearbox that are removed!</p> <p> Tip</p> <p>Lubricate the guide pins with some grease to make the upper arm slide better.</p>	<p>Guide pin, M16x150: 3HAC13120-2 Guide pin, M16x200: 3HAC13120-3 Always use guide pins in pairs.</p>  <p>xx1700000457</p>
2	<p>Leave one of the remaining attachment screws fitted, remove the other screws.</p>	 <p>xx1700000458</p>

Continues on next page

4 Repair

4.8.4 Replacing the axis-3 gearbox

Continued

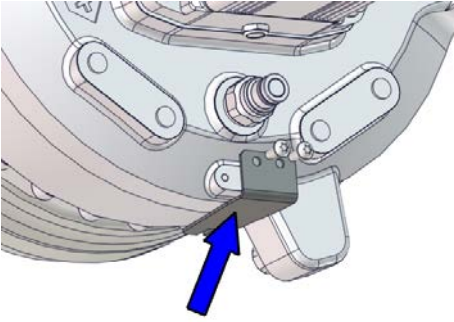
	Action	Note
3	Remove the axis-3 synchronization mark plate.	 xx170000694

Removing the upper arm

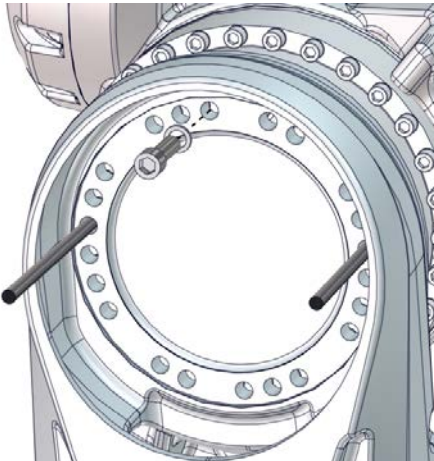
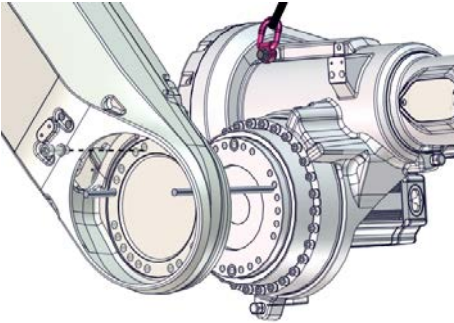
	Action	Note
1	Remove the remaining attachment screw and let the upper arm slide out from the lower arm with support from the guide pins.	 xx170000059  xx170000459
2	Lift the upper arm and place it on the prepared area.	

Continues on next page

4.8.4 Replacing the axis-3 gearbox
Continued

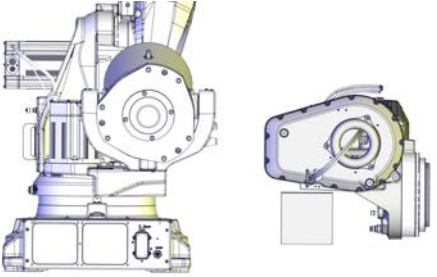
	Action	Note
3	<p><i>This step is only valid when the upper arm is removed due to replacement of the axis-3 gearbox:</i></p> <p>Place pieces of wood (or similar) under arm house and wrist. Lower the upper arm, and let the upper arm rest as shown in the figure.</p> <p>This is done in order to keep the axis-3 gearbox in a vertical position and to get the best position to replace the axis-3 gearbox, if applicable.</p>	 <p>xx1300000553</p>

Removing the axis-3 gearbox

Use this procedure to remove the gearbox.

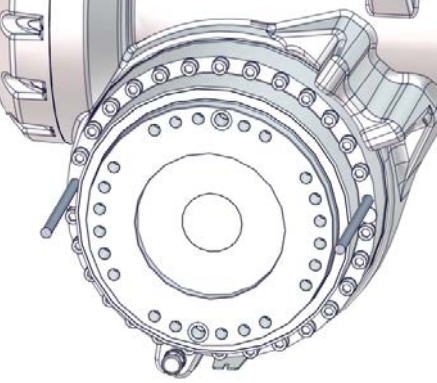
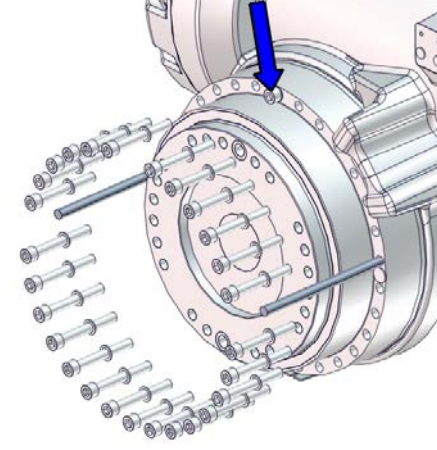

	Action	Note
1	<p>Remove two attachment screws in opposite holes and replace them with guide pins.</p> <p> Tip</p> <p>Lubricate the guide pins with some grease to make the gearbox slide better.</p>	<p>Guide pin, M12x150: 3HAC13056-2 Always use guide pins in pairs.</p>  <p>xx1700000370</p>
2	<p>Remove all but one of the remaining attachment screws.</p>	 <p>xx1700000371</p>
3	<p>Fit three fully threaded screws and use them as removal tools.</p>	<p>Screws M8x75, fully threaded: Used to push out the gearbox, if necessary.</p>
4	<p>Remove the remaining attachment screw.</p>	

Continues on next page

4 Repair

4.8.4 Replacing the axis-3 gearbox



Continued

	Action	Note
5	<p>Loosen the gearbox from its fitting position with the help of the removal tools, but only pull it out on the guide pins a little.</p> <p> DANGER</p> <p>If pulled out too far on the guide pins before the lifting accessory is applied, there is a risk the gearbox may start to glide on the guide pins with a risk of falling down!</p>	
6	<p> CAUTION</p> <p>The axis-3 gearbox weighs 85 kg. All lifting accessories used must be sized accordingly.</p>	
7	Apply the lifting accessory to the gearbox.	Lifting accessory, gearbox: 3HAC046112-001
8	<p> Note</p> <p>There will be some oil spill when the gearbox is removed! Put some oil absorbent cloth or paper below the gearbox.</p>	
9	With the gearbox attached to the lifting accessory, remove the gearbox by letting it slide out on the guide pins.	
10	Remove the gearbox.	



Refitting the axis-3 gearbox

Use these procedures to refit the axis-3 gearbox.

Preparations before refitting the axis-3 gearbox

	Action	Note
1	<p> DANGER</p> <p>Make sure that all supplies for electrical power, hydraulic pressure, and air pressure are turned off.</p>	
2	<p> CAUTION</p> <p>The axis-3 gearbox weighs 85 kg. All lifting accessories used must be sized accordingly.</p>	
3	Apply the lifting accessory to the gearbox.	Lifting accessory, gearbox: 3HAC046112-001
4	Lift the gearbox so that it rests on the side.	

Continues on next page

	Action	Note
5	Remove the o-ring and wipe it clean.  Note This shall also be done on a new spare part.	
6	Check the condition of the o-ring. Replace if damaged.	
7	Wipe clean the contact surfaces. Also wipe clean the o-ring groove.	
8	Lubricate the o-ring with some grease.	
9	Fit the o-ring in the groove.	
10	Fit two guide pins in opposite holes.  Tip Lubricate the guide pins with some grease to make the gearbox slide better.	Guide pin, M12x150: 3HAC13056-2 Always use guide pins in pairs.
11	Lift the gearbox to the upper arm and let it rest on the guide pins.	

Securing the axis-3 gearbox

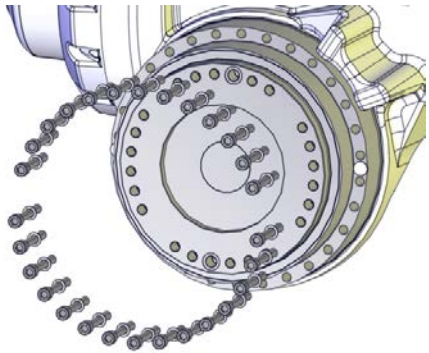
	Action	Note
1	Secure the gearbox with 28 of the 30 attachment screws.	Tightening torque: 120 Nm M12x70.  xx1400002193

Continues on next page

4 Repair

4.8.4 Replacing the axis-3 gearbox

Continued

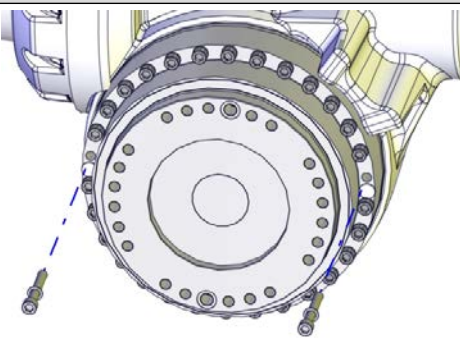
	Action	Note
2	Remove the guide pins and replace with the remaining attachment screws.	 <p>xx1400002194</p>
3	Secure the remaining attachment screws.	Tightening torque: 120 Nm. M12x70.
4	Remove the lifting accessory.	

Preparations before refitting the upper arm

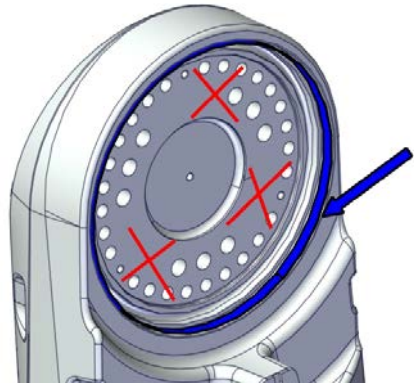
	Action	Note
1	Wipe clean all contact surfaces.	
2	<p><i>Foundry Plus:</i> Apply Mercasol on the surface on the lower arm as shown in the figure.</p> <p> CAUTION</p> <p>Keep the sealing surfaces clean from Mercasol.</p>	<p>Rust preventive: 3HAC034903-001 (Mercasol 3110 Waxcoat. Recommended drying time is 24h.)</p>  <p>xx1700001880</p>

Continues on next page

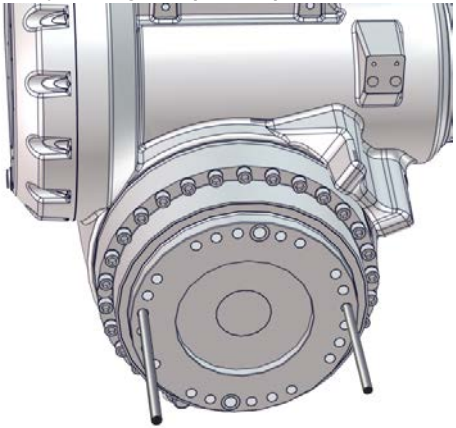
	Action	Note
3	<p>Fit two guide pins in opposite M16 holes in the axis-3 gearbox.</p> <p> Tip</p> <p>Lubricate the guide pins with some grease to make the upper arm slide better.</p>	<p>Guide pin, M16x150: 3HAC13120-2 Guide pin, M16x200: 3HAC13120-3 Always use guide pins in pairs.</p>  <p>xx1700000056</p>

Securing the upper arm

	Action	Note
1	<p> CAUTION</p> <p>The weight of the complete upper arm (including the wrist) is 465 kg All lifting accessories used must be sized accordingly.</p>	
2	Attach the lifting accessories, if not already fitted.	See Attaching lifting accessories to the upper arm on page 210 .
3	Lift the upper arm and bring it towards the lower arm.	
4	<p>If the axis-3 motor is installed to the upper arm: Connect the 24 VDC power supply, to release the brakes. Connect to R2.MP3-connector:</p> <ul style="list-style-type: none"> • + = pin 2 • - = pin 5 <p>Use the rotation tool and rotate the axis-3 motor to find the correct position for the guide pins in the lower arm. Disconnect and remove the 24 VDC power supply after finding the position.</p>	24 VDC power supply Rotation tool
5	<p>If the axis-3 motor is not installed to the upper arm: Use the pinion to rotate the axis-3 gearbox to find the correct position for the guide pins in the lower arm.</p>	Pinion: 3HAC067545-001

Continues on next page

4 Repair

4.8.4 Replacing the axis-3 gearbox

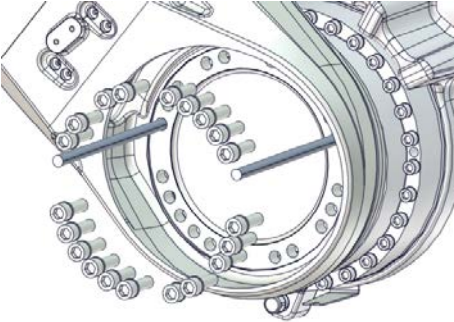
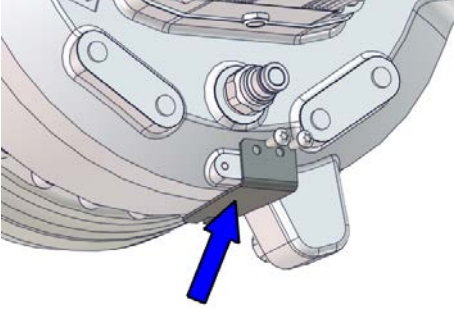

Continued

	Action	Note
6	Insert and tighten 20 of the 22 M16 screws.	 <p>xx170000460</p>
7	Remove the guide pins and fit the two remaining screws.	
8	Secure the upper arm by tightening the attachment screws.	M16, tightening torque: 300 Nm
9	Refit the axis-3 synchronization mark plate.	 <p>xx170000694</p>

Preparations prior to refitting motor

	Action	Note
1	 DANGER Make sure that all supplies for electrical power, hydraulic pressure, and air pressure are turned off.	
2	Remove any old paint residues or other contamination from the contact surfaces on both the motor and the mating parts. Wipe clean the contact surfaces and the o-ring groove.	

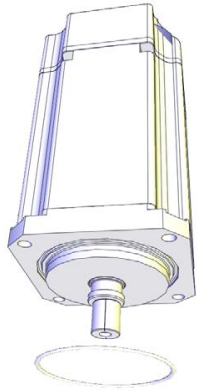
Continues on next page

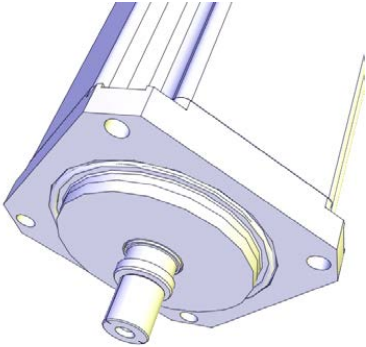
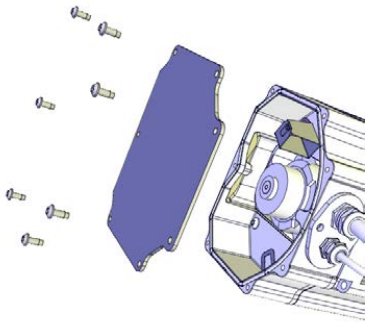

	Action	Note
3	Fit a new o-ring.	 <p>xx1200001019</p>
4	<p>Make sure the o-ring is seated in the groove.</p> <p> Tip</p> <p>Lubricate the o-ring with some grease for a better fitting in the groove.</p>	 <p>xx1200001020</p>
5	If the motor is a new spare part, remove the cover.	 <p>xx1200001135</p>

Continues on next page

4 Repair

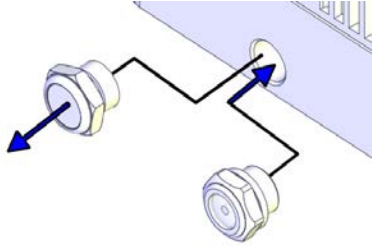

4.8.4 Replacing the axis-3 gearbox

Continued

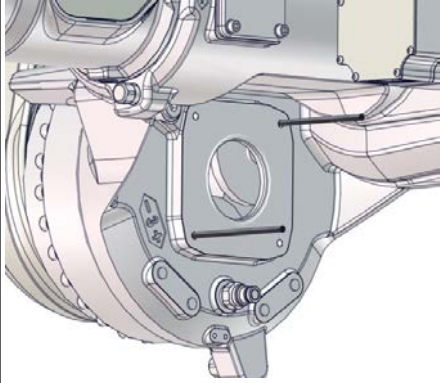

	Action	Note
6	<p>Protection type Foundry Plus Valid for axis-2, axis-3, axis-4 and axis-6 motors. If the motor is a new spare part, the evacuation hole protection filter must be replaced with a transparent plug/sight glass (enclosed with the spare part delivery). Remove the protection filter and install the transparent plug/sight glass. On the axis-6 motor there are two protection filters that must be replaced with transparent plugs/sight glasses.</p> <div style="display: flex; justify-content: space-around;"> <div style="text-align: center;">  <p>xx2200002188 Transparent plug (Foundry Plus).</p> </div> <div style="text-align: center;">  <p>xx1800000101 Protection filter (Standard).</p> </div> </div>	<p>Tightening torque, transparent plug: 20 Nm \pm10% Tightening torque, protection filter: 10 Nm \pm10%</p>  <p>xx1600000576</p>

Securing the axis-3 motor

Use this procedure to secure the motor.

	Action	Note
1	Fit guide pins in opposite holes.	<p>Guide pin, M10x150: 3HAC15521-2 Always use guide pins in pairs.</p>  <p>xx1700000272</p>
2	<p> CAUTION The motor weighs 26 kg. All lifting accessories used must be sized accordingly.</p>	

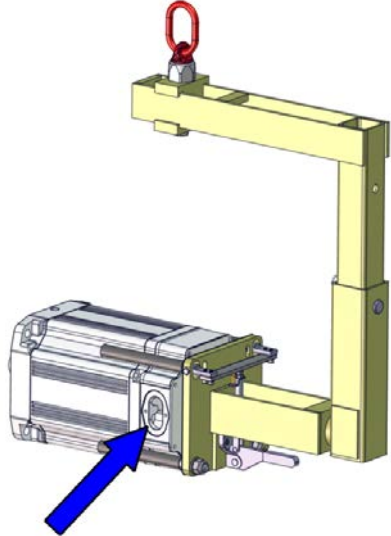
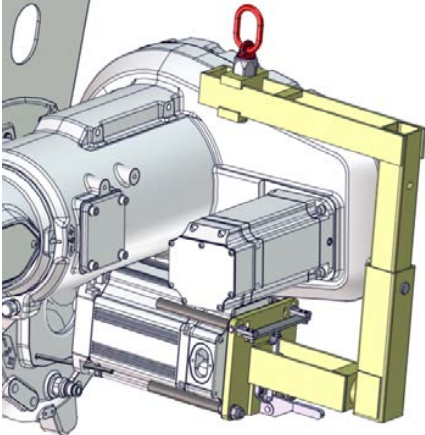
Continues on next page

	Action	Note
3	<p>Apply the lifting accessories to the motor.</p> <p> Note</p> <p>Make sure the cable gland exit is turned according to figure.</p>	<p>Lifting accessory, motor: 3HAC15534-1</p>  <p>xx1700000273</p>
4	<p>Lift the motor on to the guide pins and let it hang with the outer end a little lower when resting on the guide pins. Do not push the motor pinion into the gear yet.</p> <p>This is done in order to fit the motor with the axis-4 motor still fitted.</p>	 <p>xx1700000271</p>
5	<p>Remove the lifting accessory and allow the motor to rest on the guide pins.</p>	
6	<p>Apply the rotation tool and use it to rotate the pinion when mating it into the gear.</p>	<p>Rotation tool: 3HAB7887-1</p>
7	<p>To release the brakes, connect the 24 VDC power supply.</p> <p>Connect to connector R2.MP3:</p> <ul style="list-style-type: none"> • + = pin 2 • - = pin 5 	
8	<p> CAUTION</p> <p>Whenever parting/mating motor and gearbox, the gears may be damaged if excessive force is used.</p>	

Continues on next page

4 Repair

4.8.4 Replacing the axis-3 gearbox

Continued

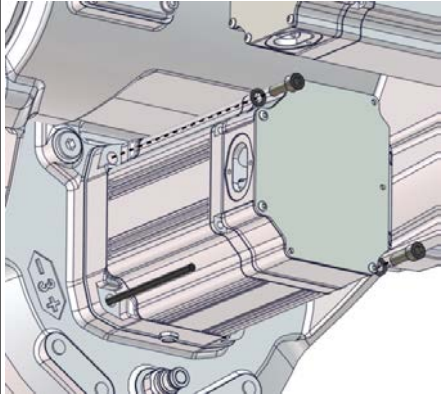
	Action	Note
9	Use caution and push the motor in position while at the same time the motor pinion is slightly rotated. Pay attention to following points: <ul style="list-style-type: none"> • Mate the motor pinion properly to the gear of the gearbox. • Do not damage the motor pinion. 	
10	Fit two of the attachment screws and washers.	Screws: M10x30 quality 12.9 Gleitmo  xx1700000259
11	Remove the guide pins.	
12	Fit the remaining attachment screws and washers.	Screws: M10x30 quality 12.9 Gleitmo
13	Tighten the screws.	Tightening torque: 50 Nm
14	Remove the rotation tool.	
15	Perform a leak-down test.	See Performing a leak-down test on page 188 .
16	Disconnect the 24 VDC power supply.	

Refitting the cable harness to the upper arm and wrist

If the cabling in the upper arm and wrist has been removed, refit it as described in [Refitting the cable harness - upper arm and wrist on page 254](#) and continue with the concluding procedure below.

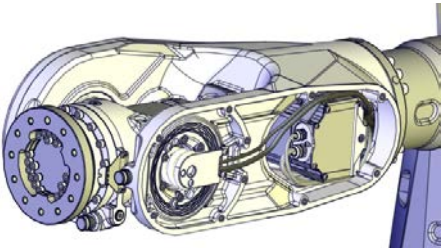
	Action	Note
1	Refit the cabling as described in Refitting the cable harness - upper arm and wrist on page 254 .	
2	Make sure that the cable harness is placed in a way that it will not be damaged when the wrist cover is fitted.	 xx1600002061
3	Inspect the gasket. Replace if damaged.	

Continues on next page

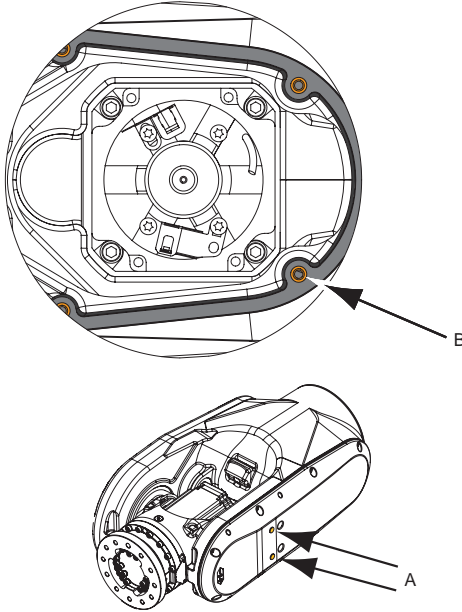
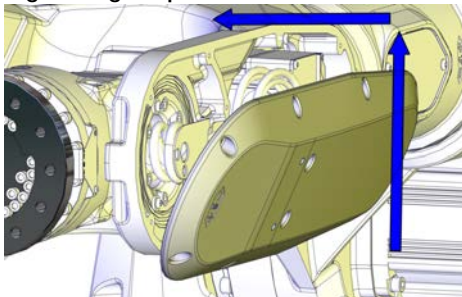
Action	Note
<p>4 <i>Foundry Plus:</i></p> <ul style="list-style-type: none"> • Make sure that the gasket is undamaged on the cover. Replace if damaged. • Put washers in the holes of the gasket. • Use attachment screws made of stainless steel to fit the wrist cover. 	 <p style="text-align: center;">xx140000383</p> <p>A Protection plugs (2 on wrist cover and 2 on cover axis-5 gearbox) B Washers (10 pcs) in gasket holes</p>
<p>5 Refit the wrist cover. Use this method not to damage the cable harness:</p> <ol style="list-style-type: none"> 1 Hold the cover tilted. See figure! 2 Put the cable harness inside the cover. 3 Lift the cover, still tilted. 4 Move the upper part of the cover into position. 5 Secure the cover with its attachment screws. 	<p>Tightening torque: 10 Nm.</p>  <p style="text-align: center;">xx130000772</p>
<p>6 <i>Foundry Plus:</i> Refit protection plugs.</p>	<p>See figure above!</p>
<p>7 If used, refit the DressPack cable package on the wrist.</p>	

Concluding procedure

Action	Note
<p>1 Refill oil in the gearbox.</p>	<p>See Filling oil into the axis-3 gearbox on page 164.</p>
<p>2 Re-calibrate the robot.</p>	<p>Axis Calibration is described in Calibrating with Axis Calibration method on page 694. General calibration information is included in section Calibration on page 683.</p>

Continues on next page

4 Repair

4.8.4 Replacing the axis-3 gearbox

Continued

	Action	Note
3	 DANGER Make sure all safety requirements are met when performing the first test run. See Test run after installation, maintenance, or repair on page 97 .	

4.8.5 Replacing the axis-6 gearbox

Location of the axis-6 gearbox

The axis-6 gearbox is located as shown in the figure.

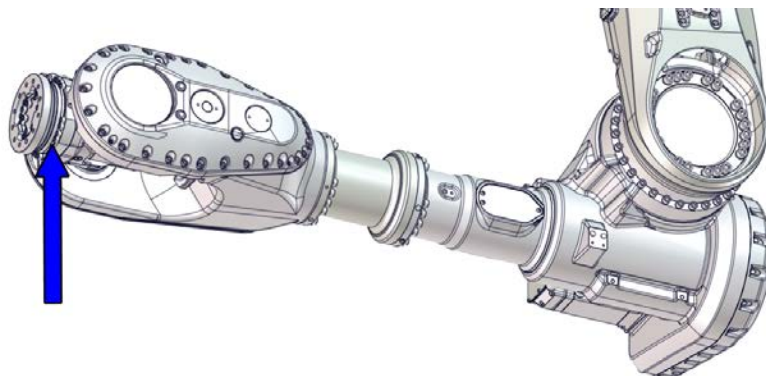

xx170000461

Spare parts

Spare parts	Spare part number	Note
Axis-6 gearbox	See <i>Product manual, spare parts - IRB 6700/IRB 6700Inv</i>	

Consumables

Equipment, etc	Article number	Note
Grease	3HAC042536-001	Shell Gadus S2 Used to lubricate o-rings.
O-ring	3HAB3772-107	D=102x3 Used on motor flange.
Gasket	3HAC033489-001	Used on motor cover.
O-ring	3HAB3772-161	Used on gearbox.

Required tools and equipment

Equipment, etc.	Article number	Note
Rotation tool	3HAB7887-1	Used to rotate the motor pinion.
24 VDC power supply	-	Used to release the motor brakes.
Leak-down tester	-	
Calibration tool box, Axis Calibration	3HAC055412-001	Delivered as a set of calibration tools.
Standard toolkit	-	Content is defined in section Standard toolkit on page 724 .

Continues on next page

4 Repair

4.8.5 Replacing the axis-6 gearbox

Continued

Deciding calibration routine

Decide which calibration routine to be used, based on the information in the table. Depending on which routine is chosen, action might be required prior to beginning the repair work of the robot, see the table.

	Action	Note
1	Decide which calibration routine to use for calibrating the robot. <ul style="list-style-type: none"> Reference calibration. External cable packages (DressPack) and tools can stay fitted on the robot. Fine calibration. All external cable packages (DressPack) and tools must be removed from the robot. 	
	If the robot is to be calibrated with reference calibration: Find previous reference values for the axis or create new reference values. These values are to be used after the repair procedure is completed, for calibration of the robot. If no previous reference values exist, and no new reference values can be created, then reference calibration is not possible.	Follow the instructions given in the reference calibration routine on the FlexPendant to create reference values. Creating new values requires possibility to move the robot. Read more about reference calibration for Axis Calibration in Reference calibration routine on page 695 .
	If the robot is to be calibrated with fine calibration: Remove all external cable packages (DressPack) and tools from the robot.	



Removing the axis-6 gearbox

Use these procedures to remove the axis-6 gearbox.

Preparations before removing the axis-6 gearbox

	Action	Note
1	Decide which calibration routine to use, and take actions accordingly prior to beginning the repair procedure.	
2	 DANGER Turn off all: <ul style="list-style-type: none"> electric power supply hydraulic pressure supply air pressure supply to the robot, before entering the safeguarded space.	
3	Drain the gearbox.	See Draining the axis-6 gearbox on page 176 .
4	Remove all equipment fitted on the turning disc.	

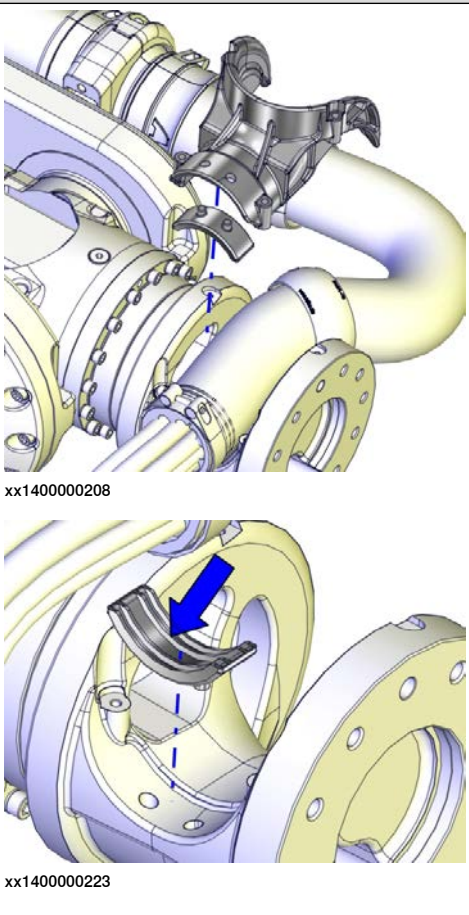
Continues on next page

	Action	Note
5	If installed, remove the DressPack axis-6 support.	 <p>xx140000208</p> <p>xx140000223</p>
6	<p>Jog the robot to:</p> <ul style="list-style-type: none"> • Axis 1 = No significance (as long as the robot is secured to the foundation). • Axis 2 = no significance • Axis 3 = no significance • Axis 4 = 0° • Axis 5 = +55° • Axis 6 = -10° 	
7	<p> DANGER</p> <p>Turn off all:</p> <ul style="list-style-type: none"> • electric power supply • hydraulic pressure supply • air pressure supply <p>to the robot, before entering the safeguarded space.</p>	

Continues on next page

4 Repair

4.8.5 Replacing the axis-6 gearbox

Continued

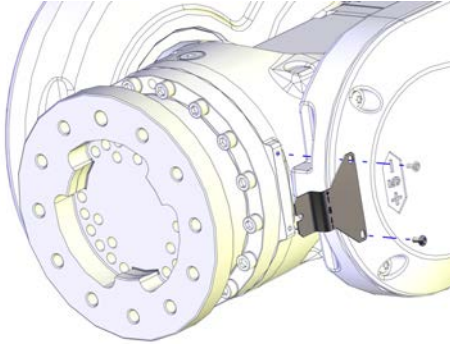

	Action	Note
8	Remove the synchronization plate axis-6.	 xx130000825

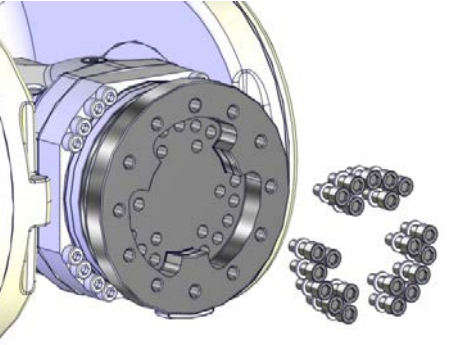
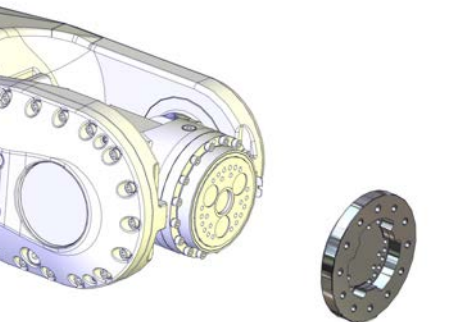
Removing the turning disc

	Action	Note
1	Remove the screws and washers, that secure the turning disc.	 xx140002195
2	Remove the turning disc.	 xx130000493

Continues on next page

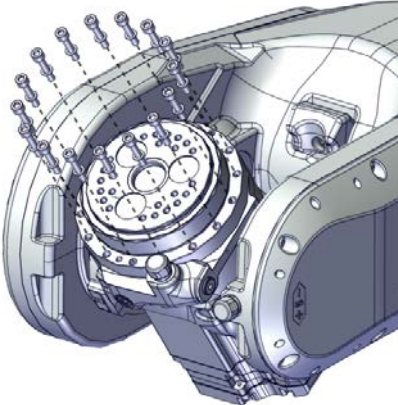
Removing the axis-6 gearbox

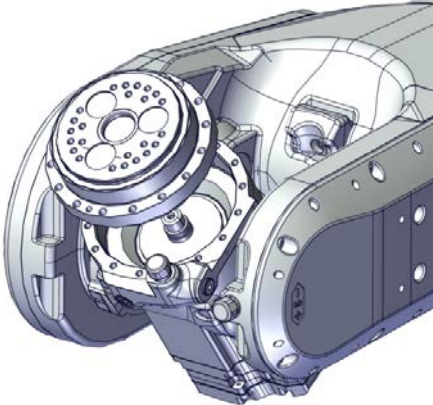
	Action	Note
1	Unscrew the attachment screws that secure the axis-6 gearbox.	<p>M8x50 quality 12.9 Gleitmo, 16 pcs</p>  <p>xx1700001600</p>
2	 CAUTION Whenever parting/mating motor and gearbox, the gears may be damaged if excessive force is used.	
3	Remove the gearbox. If required fit two attachment screws and press out the gearbox.	 <p>xx1700001601</p>

Refitting the axis-6 gearbox

Use these procedures to refit the gearbox.

Preparations before refitting the axis-6 gearbox

	Action	Note
1	 DANGER Make sure that all supplies for electrical power, hydraulic pressure, and air pressure are turned off.	

Continues on next page



4 Repair

4.8.5 Replacing the axis-6 gearbox

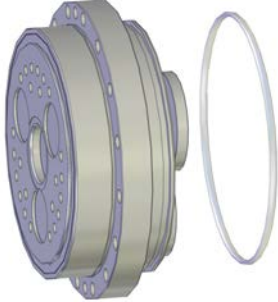
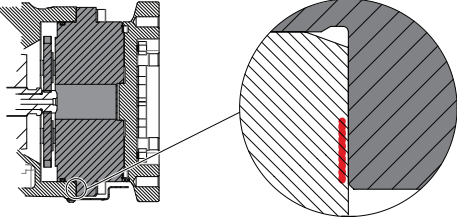
Continued

	Action	Note
2	<p>Ensure a tight fitting of the sealing according to following steps:</p> <ul style="list-style-type: none"> Remove the o-ring and wipe it clean. <p> Note</p> <p>The o-ring needs to be cleaned also on a new spare part.</p> <ul style="list-style-type: none"> Check the o-ring. Replace if damaged. Wipe clean the contact surfaces from any contamination. Also wipe clean the o-ring groove. Put some grease on the o-ring. Fit the o-ring in the groove of the gearbox. 	<p>O-ring: 3HAB3772-161</p>  <p>xx1300000828</p>
3	<p><i>Foundry Plus:</i></p> <p>Apply Loctite 574 on the surface shown in the figure.</p>	 <p>xx1400000717</p>

Refitting the axis-6 gearbox

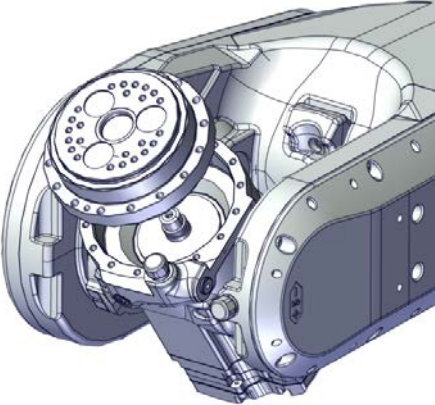
	Action	Note
1	<p> CAUTION</p> <p>Whenever parting/mating motor and gearbox, the gears may be damaged if excessive force is used.</p>	
2	<p>Fit the gearbox to the wrist.</p> <p> CAUTION</p> <p>Be careful not to damage motor pinion or gears!</p>	 <p>xx1700001601</p>

Continues on next page

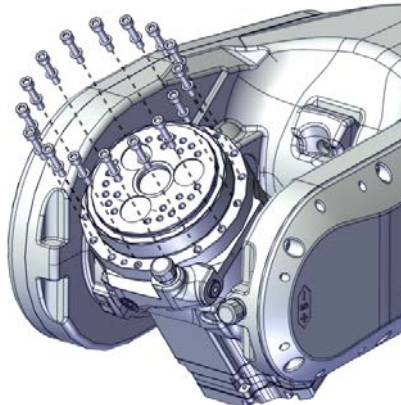
Action	Note
3 Secure the gearbox with its attachment screws.	<p>Screws: M8x50 quality 12.9 Gleitmo, 16 pcs Tightening torque: 35 Nm</p>  <p style="text-align: right; font-size: small;">xx1700001600</p>
4 Perform a leak-down test.	See Performing a leak-down test on page 188 .
5 Jog axis-5 to horizontal position.	
6 Refill oil in the gearbox.	See Filling oil into the axis-6 gearbox on page 177 .

Refitting the turning disc

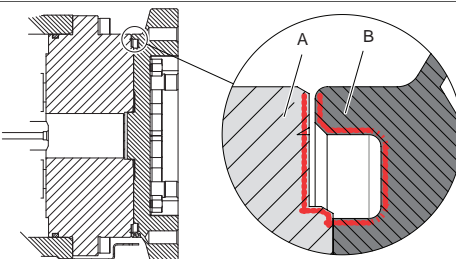
Action	Note
1 If new turning disc spare part is installed: verify that the correct synchronization mark plate for axis-6 is installed on the wrist.	See Replacing the synchronization mark plate on page 338 .
2 Wipe clean the contact surfaces.	
3 Foundry Plus: Apply Mercasol on the surfaces on turning disc and axis-6 gearbox as shown in the figure.	 <p style="text-align: right; font-size: small;">xx1400000385</p>

Continues on next page



4 Repair

4.8.5 Replacing the axis-6 gearbox

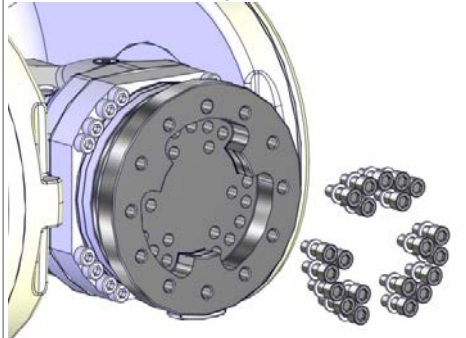
Continued

	Action	Note
4	Secure the turning disc with its attachment screws and washers.	<p>Tightening torque: 70 Nm Attachment screws: M10x25, Steel 12.9 Gleitmo 603, (21 pcs) Washers: Steel (21 pcs)</p>  <p>xx1400002195</p>

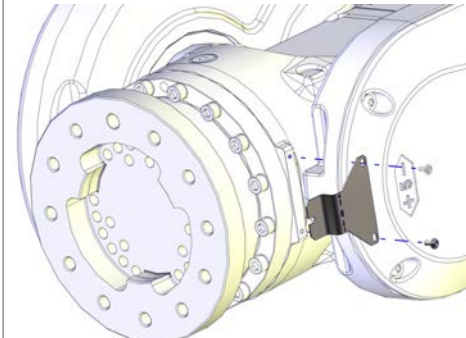
Concluding procedure

	Action	Note
1	Refit the synchronization plate axis-6.	 <p>xx1300000825</p>
2	Re-calibrate the robot.	<p>Axis Calibration is described in Calibrating with Axis Calibration method on page 694. General calibration information is included in section Calibration on page 683.</p>
3	 <p>DANGER</p> <p>Make sure all safety requirements are met when performing the first test run. See Test run after installation, maintenance, or repair on page 97.</p>	

5 Calibration

5.1 Introduction to calibration

5.1.1 Introduction and calibration terminology

Calibration information

This chapter includes general information about the recommended calibration methods and also the detailed procedures for updating the revolution counters, checking the calibration position etc.

Detailed instructions of how to perform Axis Calibration are given on the FlexPendant during the calibration procedure. To prepare calibration with Axis Calibration method, see [Calibrating with Axis Calibration method on page 694](#).

Calibration terminology

Term	Definition
Calibration method	A collective term for several methods that might be available for calibrating the ABB robot. Each method contains calibration routines.
Synchronization position	Known position of the complete robot where the angle of each axis can be checked against visual synchronization marks.
Calibration position	Known position of the complete robot that is used for calibration of the robot.
Standard calibration	A generic term for all calibration methods that aim to move the robot to calibration position.
Fine calibration	A calibration routine that generates a new zero position of the robot.
Reference calibration	<p>A calibration routine that in the first step generates a reference to current zero position of the robot. The same calibration routine can later on be used to recalibrate the robot back to the same position as when the reference was stored.</p> <p>This routine is more flexible compared to fine calibration and is used when tools and process equipment are installed.</p> <p>Requires that a reference is created before being used for recalibrating the robot.</p> <p>Requires that the robot is dressed with the same tools and process equipment during calibration as during creation of the reference values.</p>
Update revolution counter	A calibration routine to make a rough calibration of each manipulator axis.
Synchronization mark	Visual marks on the robot axes. When marks are aligned, the robot is in synchronization position.

5 Calibration

5.1.2 Calibration methods

5.1.2 Calibration methods

Overview

This section specifies the different types of calibration and the calibration methods that are supplied by ABB.

Types of calibration

Type of calibration	Description	Calibration method
Standard calibration	The calibrated robot is positioned at calibration position. Standard calibration data is found on the SMB (serial measurement board) or EIB in the robot. For robots with RobotWare 5.04 or older, the calibration data is delivered in a file, calib.cfg, supplied with the robot at delivery. The file identifies the correct resolver/motor position corresponding to the robot home position.	Axis Calibration
Optimization	Optimization of TCP reorientation performance. The purpose is to improve reorientation accuracy for continuous processes like welding and gluing. Wrist optimization will update standard calibration data for axes 4 and 5.	Wrist Optimization

Brief description of calibration methods

Axis Calibration method

Axis Calibration is a standard calibration method for calibration of IRB 6700Inv / IRB 6700I. It is the recommended method in order to achieve proper performance.

The following routines are available for the Axis Calibration method:

- Fine calibration
- Update revolution counters
- Reference calibration

The calibration equipment for Axis Calibration is delivered as a toolkit.

An introduction to the calibration method is given in this manual, see [Calibrating with Axis Calibration method on page 694](#).

The actual instructions of how to perform the calibration procedure and what to do at each step is given on the FlexPendant. You will be guided through the calibration procedure, step by step.

Wrist Optimization method

Wrist Optimization is a method for improving reorientation accuracy for continuous processes like welding and gluing and is a complement to the standard calibration method.

The actual instructions of how to perform the wrist optimization procedure is given on the FlexPendant.

Continues on next page

References

Article numbers for the calibration tools are listed in the section [Special tools on page 725](#).

5 Calibration

5.1.3 When to calibrate

5.1.3 When to calibrate

When to calibrate

The system must be calibrated if any of the following situations occur.

The resolver values are changed

If resolver values are changed, the robot must be re-calibrated using the calibration methods supplied by ABB. Calibrate the robot carefully with standard calibration, according to information in this manual.

The resolver values will change when parts affecting the calibration position are replaced on the robot, for example motors or parts of the transmission.

The revolution counter memory is lost

If the revolution counter memory is lost, the counters must be updated. See [Updating revolution counters on page 690](#). This will occur when:

- The battery is discharged
- A resolver error occurs
- The signal between a resolver and measurement board is interrupted
- A robot axis is moved with the control system disconnected

The revolution counters must also be updated after the robot and controller are connected at the first installation.

The robot is rebuilt

If the robot is rebuilt, for example, after a crash or when the reachability of a robot is changed, it needs to be re-calibrated for new resolver values.

5.2 Synchronization marks and axis movement directions

5.2.1 Synchronization marks and synchronization position for axes

Introduction

This section shows the position of the synchronization marks and the synchronization position for each axis.

Synchronization marks, IRB 6700Inv

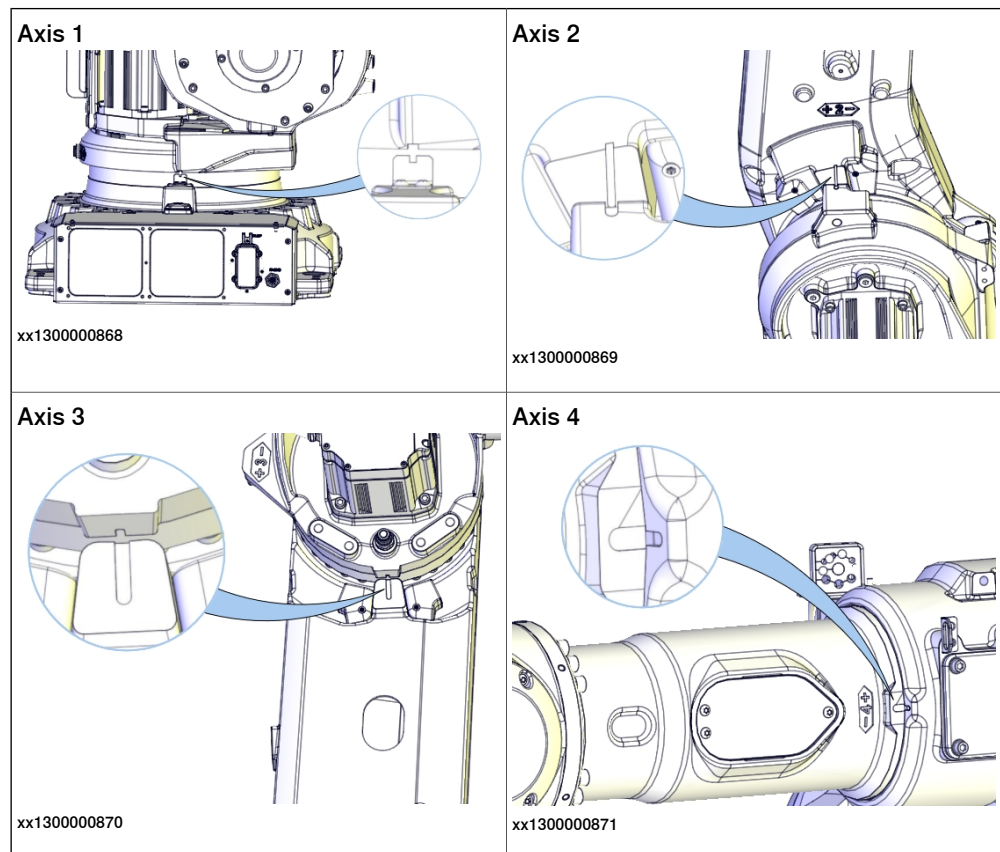

Continues on next page

5 Calibration

5.2.1 Synchronization marks and synchronization position for axes

Continued

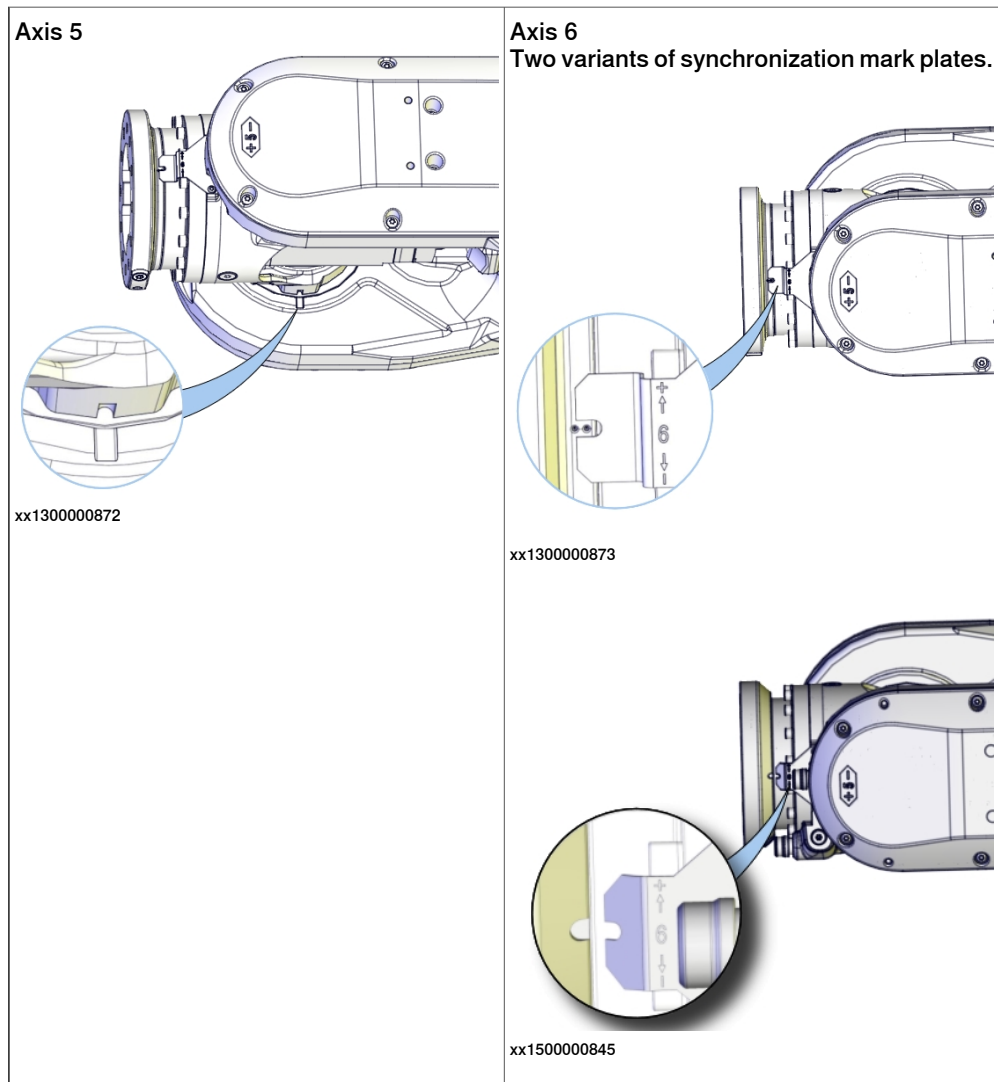

5.2.2 Calibration movement directions for all axes

Overview

When calibrating, the axis must consistently be run towards the calibration position in the same direction in order to avoid position errors caused by backlash in gears and so on. Positive directions are shown in the graphic below.

Calibration service routines will handle the calibration movements automatically and these might be different from the positive directions shown below.

Manual movement directions, 6 axes

Note! The graphic shows an IRB 7600. The positive direction is the same for all 6-axis robots, except the positive direction of axis 3 for IRB 6400R, which is in the opposite direction!

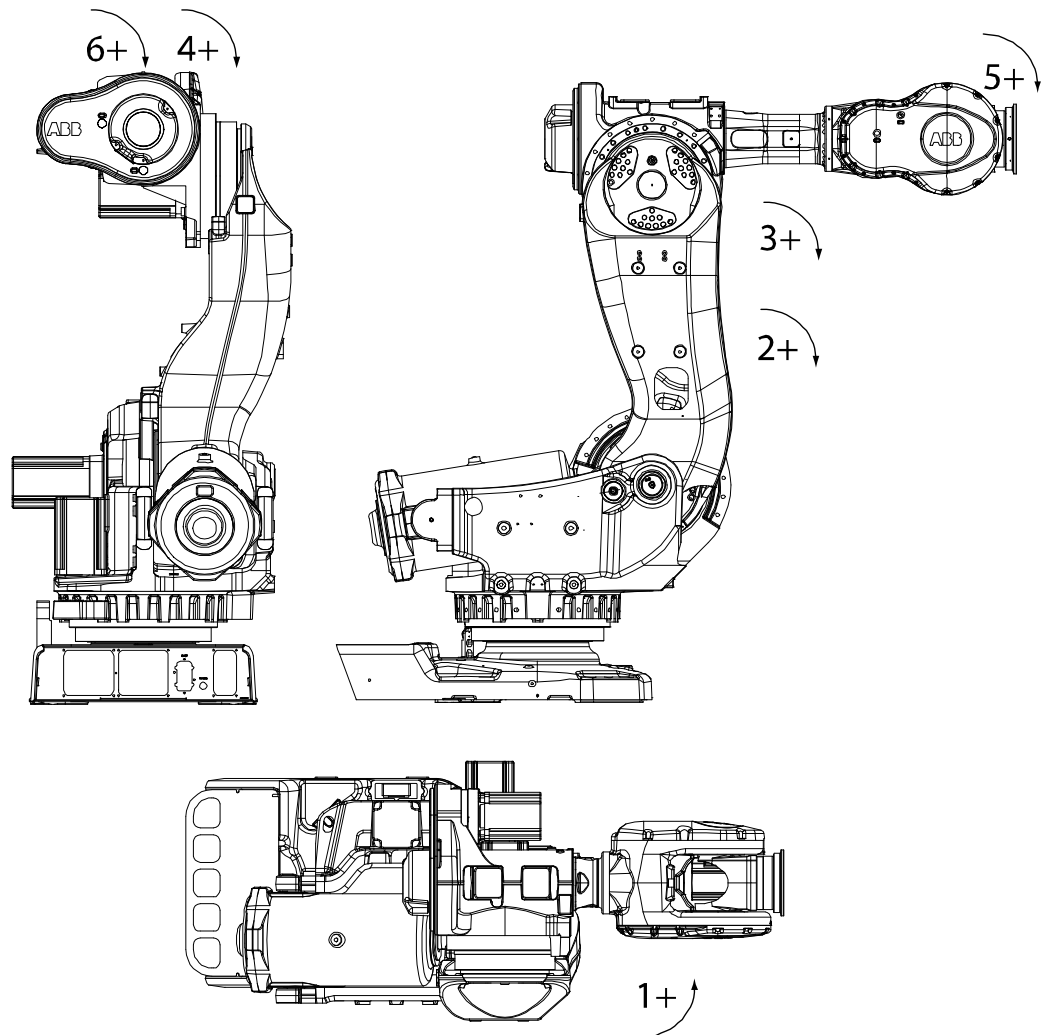

xx020000089

5 Calibration

5.3.1 Updating revolution counters on IRC5 robots

5.3 Updating revolution counters

5.3.1 Updating revolution counters on IRC5 robots

Introduction

This section describes how to do a rough calibration of each manipulator axis by updating the revolution counter for each axis, using the FlexPendant.

Step 1 - Manually running the manipulator to the synchronization position

Use this procedure to manually run the manipulator to the synchronization position.

	Action	Note
1	Select axis-by-axis motion mode.	
2	Jog the manipulator to align the synchronization marks.	See Synchronization marks and synchronization position for axes on page 687 .
3	When all axes are positioned, update the revolution counter.	Step 2 - Updating the revolution counter with the FlexPendant on page 690 .

Step 2 - Updating the revolution counter with the FlexPendant

Use this procedure to update the revolution counter with the FlexPendant (IRC5).

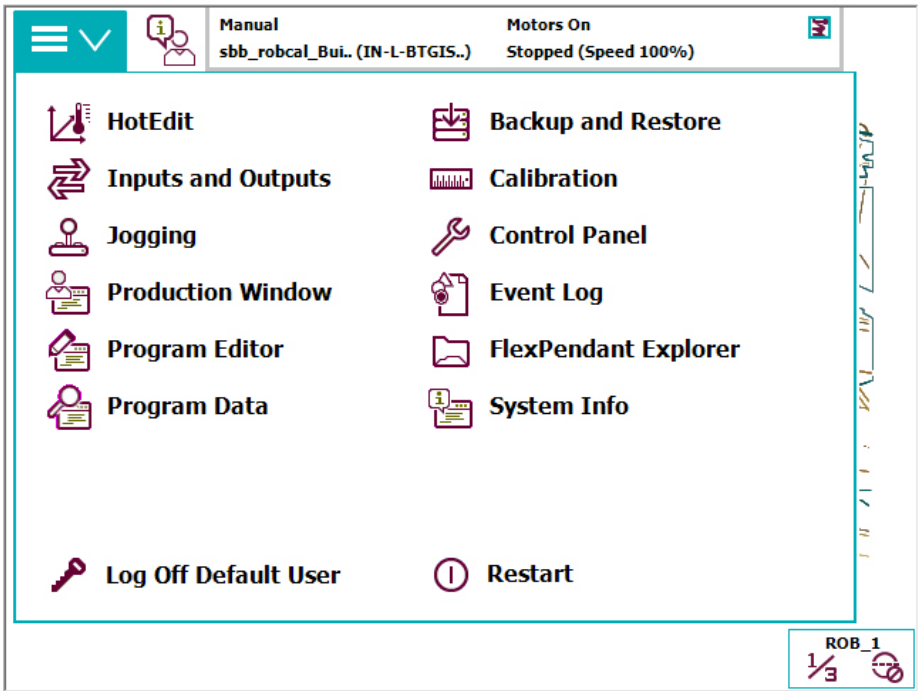
	Action
1	On the ABB menu, tap Calibration.  The screenshot shows the ABB FlexPendant menu with the following options: HotEdit, Backup and Restore, Inputs and Outputs, Calibration, Jogging, Control Panel, Production Window, Event Log, Program Editor, FlexPendant Explorer, Program Data, System Info, Log Off Default User, and Restart. The 'Calibration' option is highlighted with a blue border. The top status bar shows 'Manual sbb_robcal_Bui.. (IN-L-BTGIS..)' and 'Motors On Stopped (Speed 100%)'. The bottom right corner shows 'ROB_1' and a battery level indicator.

xx150000942

Continues on next page

Action

2 All mechanical units connected to the system are shown with their calibration status. Tap the mechanical unit in question.

Manual sbb_robcal_Bui.. (IN-L-BTGIS..) Motors On Stopped (Speed 100%)

Calibration

In order to use the system all mechanical units must be calibrated.

Select the mechanical unit you want to calibrate.

Mechanical Unit	Status
ROB_1	Calibrated

Calibration

ROB_1 1/3

xx1500000943

3 This step is valid for RobotWare 6.02 and later. Calibration method used at factory for each axis is shown, as well as calibration method used during last field calibration. Tap Manual Method (Advanced).

Manual sbb_robcal_Bui.. (IN-L-BTGIS..) Motors On Stopped (Speed 100%)

Calibration - ROB_1

ROB_1: Calibrated

Calibration Method Overview

Axis	Factory Method Used	Latest Method Used
rob1_1	Axis Calibration	Axis Calibration
rob1_2	Axis Calibration	Manual
rob1_3	Axis Calibration	Manual
rob1_4	Axis Calibration	Axis Calibration
rob1_5	Axis Calibration	Axis Calibration
rob1_6	Axis Calibration	Manual

Manual Method (Advanced) Run Calibration Method Close

Calibration

ROB_1 1/3



xx1500000944

Continues on next page

5 Calibration

5.3.1 Updating revolution counters on IRC5 robots

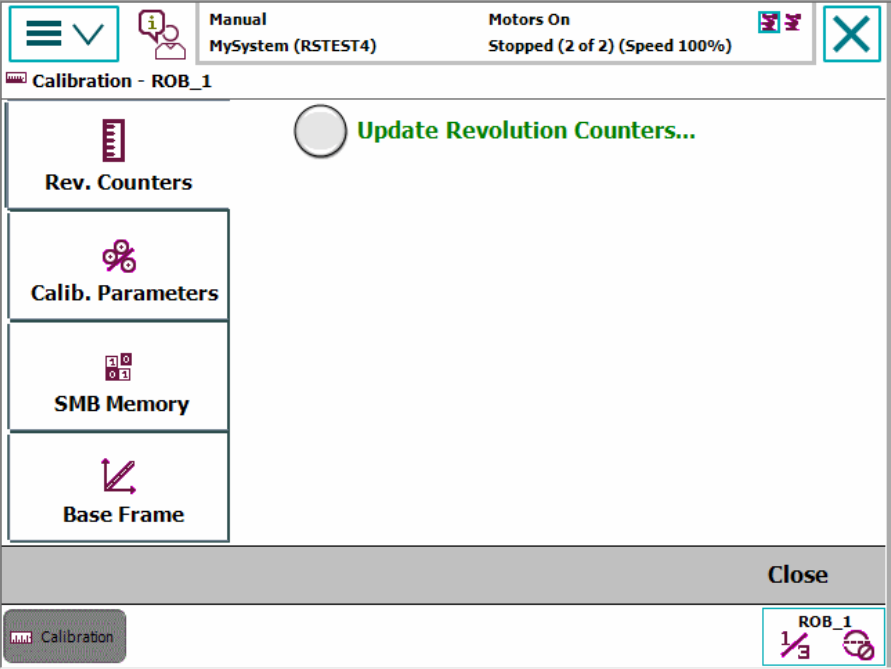
Continued

Action	
4	<p>A screen is displayed, tap Rev. Counters.</p>  <p>en040000771</p>
5	<p>Tap Update Revolution Counters...</p> <p>A dialog box is displayed, warning that updating the revolution counters may change programmed robot positions:</p> <ul style="list-style-type: none">• Tap Yes to update the revolution counters.• Tap No to cancel updating the revolution counters. <p>Tapping Yes displays the axis selection window.</p>
6	<p>Select the axis to have its revolution counter updated by:</p> <ul style="list-style-type: none">• Ticking in the box to the left• Tapping Select all to update all axes. <p>Then tap Update.</p>
7	<p>A dialog box is displayed, warning that the updating operation cannot be undone:</p> <ul style="list-style-type: none">• Tap Update to proceed with updating the revolution counters.• Tap Cancel to cancel updating the revolution counters. <p>Tapping Update updates the selected revolution counters and removes the tick from the list of axes.</p>
8	<p> CAUTION</p> <p>If a revolution counter is incorrectly updated, it will cause incorrect manipulator positioning, which in turn may cause damage or injury!</p> <p>Check the synchronization position very carefully after each update. See Checking the synchronization position on page 709.</p>

5.3.2 Updating revolution counters on OmniCore robots

Introduction

This section describes how to do a rough calibration of each manipulator axis by updating the revolution counter for each axis, using the FlexPendant.

Step 1 - Manually running the manipulator to the synchronization position

Use this procedure to manually run the manipulator to the synchronization position.

	Action	Note
1	Select axis-by-axis motion mode.	
2	Jog the manipulator to align the synchronization marks.	See Synchronization marks and synchronization position for axes on page 687 .
3	When all axes are positioned, update the revolution counter.	Step 2 - Updating the revolution counter with the FlexPendant on page 693 .

Step 2 - Updating the revolution counter with the FlexPendant

Use this procedure to update the revolution counter with the FlexPendant (OmniCore).

	Action
1	On the start screen, tap Calibrate . The calibration summary page for the mechanical unit is displayed.
2	In the Calibration Methods menu, select Revolution Counters .
3	In the Selection column select the axes for which revolution counters need to be updated.
4	Tap Update . A dialog box is displayed warning that the updating operation cannot be undone.
5	Tap OK to update the revolution counter.
6	 CAUTION If a revolution counter is incorrectly updated, it will cause incorrect manipulator positioning, which in turn may cause damage or injury! Check the synchronization position very carefully after each update. See Checking the synchronization position on page 709 .

5 Calibration

5.4.1 Description of Axis Calibration

5.4 Calibrating with Axis Calibration method

5.4.1 Description of Axis Calibration

Instructions for Axis Calibration procedure given on the FlexPendant

The actual instructions of how to perform the calibration procedure and what to do at each step is given on the FlexPendant. You will be guided through the calibration procedure, step by step.

This manual contains a brief description of the method, additional information to the information given on the FlexPendant, article number for the tools and images of where to fit the calibration tools on the robot.

Overview of the Axis Calibration procedure

The Axis Calibration procedure applies to all axes, and is performed on one axis at the time. The robot axes are both manually and automatically moved into position, as instructed on the FlexPendant.

A fixed calibration pin/bushing is installed on each robot axis at delivery.

The Axis Calibration procedure described roughly:

- 1 A removable calibration tool is inserted by the operator into a calibration bushing on the axis chosen for calibration, according to instructions on the FlexPendant.



WARNING

Calibrating the robot with Axis Calibration requires special calibration tools from ABB. Using other pins in the calibration bushings may cause severe damage to the robot and/or personnel.



WARNING

The calibration tool must be fully inserted into the calibration bushing, until the steel spring ring snaps into place.

- 2 During the calibration procedure, RobotWare moves the robot axis chosen for calibration so that the calibration tools get into contact. RobotWare records values of the axis position and repeats the coming-in-contact procedure several times to get an exact value of the axis position.



WARNING

Risk of pinching! The contact force for large robots can be up to 150 kg. Keep a safe distance to the robot.

- 3 The axis position is stored in RobotWare with an active choice from the operator.

Continues on next page

Routines in the calibration procedure

The following routines are available in the Axis Calibration procedure, given at the beginning of the procedure on the FlexPendant.

Fine calibration routine

Choose this routine to calibrate the robot when there are no tools, process cabling or equipment fitted to the robot.

Reference calibration routine

Choose this routine to create reference values and to calibrate the robot when the robot is dressed with tools, process cabling or other equipment.



Note

When calibrating the robot with the reference calibration routine, the robot must be dressed with the same tools, process cabling and any other equipment as when the reference values were created.



Note

When using reference calibration with some tools, typically large or flexible tools, oscillations in the robot can cause issues leading to failure of the calibration.

If calibrating the robot with reference calibration there must be reference values created before repair is made to the robot, if values are not already available. Creating new values requires possibility to move the robot. The reference values contain positions of all axes, torque of axes and technical data about the tool installed. A benefit with reference calibration is that the current state of the robot is stored and not the state when the robot left the ABB factory. The reference value will be named according to tool name, date etc.

Follow the instructions given in the reference calibration routine on the FlexPendant to create reference values.

When reference calibration is performed, the robot is restored to the status given by the reference values.

Update revolution counters

Choose this routine to make a rough calibration of each manipulator axis by updating the revolution counter for each axis, using the FlexPendant.

Validation

In the mentioned routines, it is also possible to validate the calibration data.

Position of robot axes

The robot axes should be positioned close to 0 degrees before commencing the calibration program. The axis chosen for calibration is then automatically run by the calibration program to its exact calibration position during the calibration procedure.

It is possible to position some of the other axes in positions different from 0 degrees. Information about which axes are allowed to be jogged is given on the FlexPendant.

Continues on next page

5 Calibration

5.4.1 Description of Axis Calibration

Continued

These axes are marked with **Unrestricted** in the FlexPendant window. Also the following table shows the dependencies between the axes.

Requirements for axis positioning during calibration

Required position of axis	Axis to calibrate					
	Axis 1	Axis 2	Axis 3	Axis 4	Axis 5	Axis 6
Axis 1	-	*	*	*	*	*
Axis 2	0	-	0	*	*	*
Axis 3	0	0	-	*	*	*
Axis 4	*	*	*	-	*	*
Axis 5	*	*	*	*	-	*
Axis 6	*	*	*	*	*	-

-	Axis to be calibrated
*	Unrestricted. Axis is allowed to be jogged to other position than 0 degrees.
0	Axis must be put in position 0 degrees.

System containing SafeMove

SafeMove will lose its synchronization to the controller if a new calibration is done. New calibration values have to be downloaded to SafeMove, and a new SafeMove calibration has to be done. Make sure that the user rights admit to change the safety settings and to synchronize SafeMove.

For robots with EPS, the same applies as for SafeMove.

How to calibrate an inverted robot

The IRB 6700Inv / IRB 6700I is calibrated inverted in factory, prior to shipping. To recalibrate an inverted robot, use either fine calibration or reference calibration routine.

5.4.2 Calibration tools for Axis Calibration

Calibration tool set

The calibration tools used for Axis Calibration are designed to meet requirements for calibration performance, durability and safety in case of accidental damage.

The calibration tool will eventually break from fatigue after longer period of use and then needs to be replaced. There is no risk for bad calibrations as long as the calibration tool is in one piece.



WARNING

Calibrating the robot with Axis Calibration requires special calibration tools from ABB. Using other pins in the calibration bushings may cause severe damage to the robot and/or personnel.

Equipment, etc.	Article number	Note
Calibration tool box, Axis Calibration	3HAC055412-001	Delivered as a set of calibration tools.

Examining the calibration tool

Check prior to usage

Before using the calibration tool, make sure that the tube insert, the plastic protection and the steel spring ring are present.



WARNING

If any part is missing or damaged, the tool must be replaced immediately.

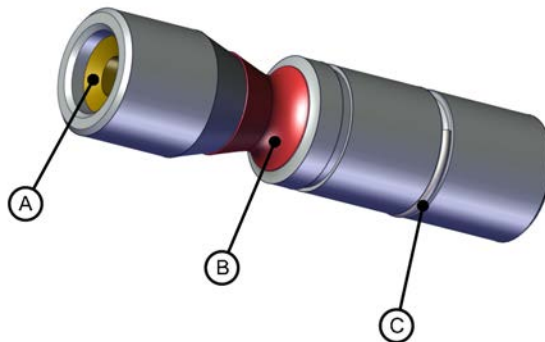

xx1500001914

A	Tube insert
B	Plastic protection
C	Steel spring ring

Continues on next page

5 Calibration

5.4.2 Calibration tools for Axis Calibration

Continued

Periodic check of the calibration tool

If including the calibration tool in a local periodic check system, the following measures should be checked.

- Outer diameter within $\varnothing 12g4$ mm, $\varnothing 8g4$ mm or $\varnothing 6g5$ mm (depending on calibration tool size).
- Straightness within 0.005 mm.

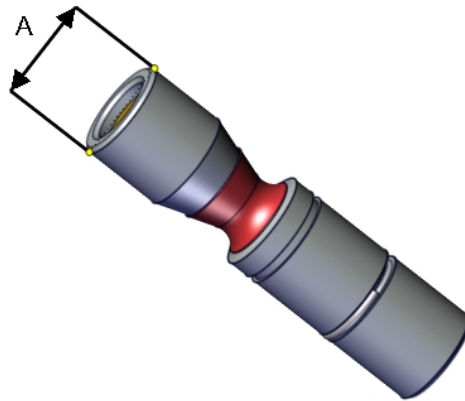

xx150000951

A	Outer diameter
---	----------------

Identifying the calibrating tools

It is possible to make the calibration tool identifiable with, for example, an RFID chip. The procedure of how to install an RFID chip is described below.



Note

The tool identifier is NOT delivered from ABB, it is a customized solution.

	Action	Note
1	<p>It is possible to use any RFID solution, with the correct dimensions. ABB has verified function on some suppliers fulfilling the requirements of NFC compatible devices (13.56 Mhz) according to ISO 14443 or ISO 15693.</p> <div style="margin-top: 10px;"> <p>Note</p> <p>The maximum dimensions on the RFID chip must not exceed $\varnothing 7.9$ mm x 8.0 mm, $\varnothing 5.9$ mm x 8.0 mm or $\varnothing 3.9$ mm x 8.0 mm (depending on calibration tool size).</p> </div>	
2	<p>There is a cavity on one end of the calibration tool in which the RFID chip can be installed.</p> <p>Install the RFID chip according to supplier instructions.</p> <p>Install the chip in flush with the tool end.</p>	

5.4.3 Installation locations for the calibration tools

Location of fixed calibration items

This section shows how the robot is equipped with items for installation of calibration tools for Axis Calibration (fixed calibration pins and/or bushings). Installed calibration tools are not shown.

A fixed calibration pin and a bushing for the movable calibration tool are located on each axis as follows.

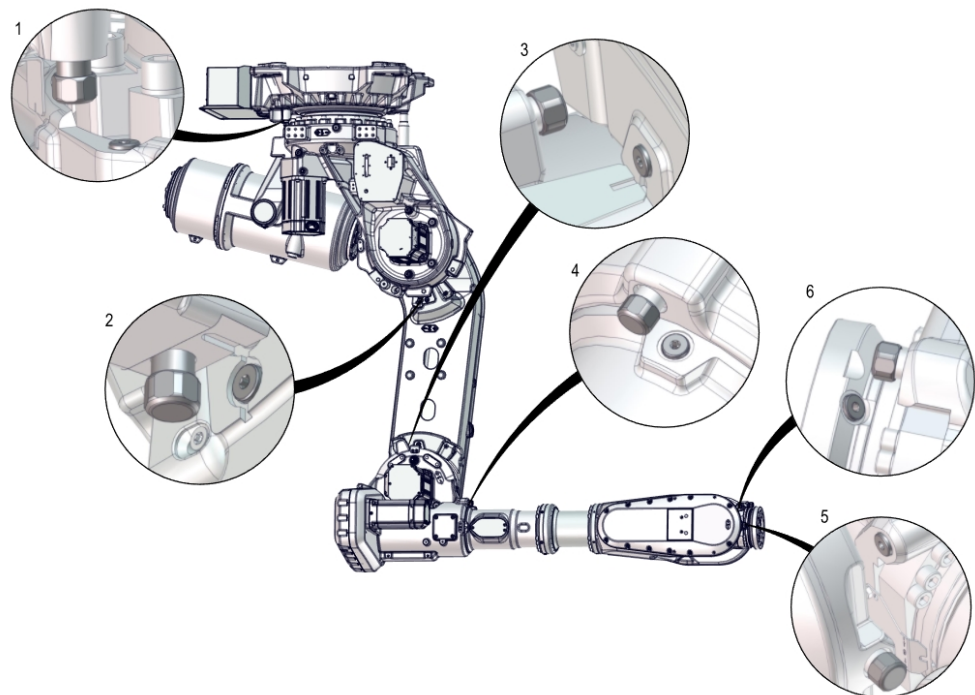

xx170000514

Spare parts

When calibration is not being performed, a protective cover and an o-ring should always be installed on the fixed calibration pin as well as a protective plug, included a sealing, in the bushing. Replace damaged parts with new.

Spare part	Article number	Note
Protection cover and plug set	3HAC056806-001	Contains replacement calibration pin covers and protective plugs for the bushing.

5 Calibration

5.4.4 Axis Calibration - Running the calibration procedure

5.4.4 Axis Calibration - Running the calibration procedure

Required tools

The calibration tools used for Axis Calibration are designed to meet requirements for calibration performance, durability and safety in case of accidental damage.



WARNING

Calibrating the robot with Axis Calibration requires special calibration tools from ABB. Using other pins in the calibration holes may cause severe damage to the robot and/or personnel.

Equipment, etc.	Article number	Note
Calibration tool box, Axis Calibration	3HAC055412-001	Delivered as a set of calibration tools.

Required consumables

Consumable	Article number	Note
Clean cloth	-	

Spare parts

Spare part	Article number	Note
Protection cover and plug set	3HAC056806-001	Contains replacement calibration pin covers and protective plugs for the bushing.

Overview of the calibration procedure on the FlexPendant

The actual instructions of how to perform the calibration procedure and what to do at each step is given on the FlexPendant. You will be guided through the calibration procedure, step by step.

Use the following list to learn about the calibration procedure before running the RobotWare program on the FlexPendant. It gives you a brief overview of the calibration procedure.

After the calibration method has been started on the FlexPendant, the following sequence will be run.

- 1 Choose calibration routine. The routines are described in [Routines in the calibration procedure on page 695](#).
- 2 Choose which axis/axes to calibrate.
- 3 The robot moves to synchronization position.
- 4 Validate the synchronization marks.
- 5 The robot moves to preparation position.
- 6 Remove the protective cover from the fixed pin and the protection plug from the bushing, if any, and install the calibration tool.
- 7 The robot performs a measurement sequence by rotating the axis back and forth.

Continues on next page

5.4.4 Axis Calibration - Running the calibration procedure



Continued

- 8 Remove the calibration tool and reinstall the protective cover on the fixed pin and the protection plug in the bushing, if any.
- 9 The robot moves to verify that the calibration tool is removed.
- 10 Choose whether to save the calibration data or not.

Calibration of the robot is not finished until the calibration data is saved, as last step of the calibration procedure.

Preparation prior to calibration

The calibration procedure is described in the FlexPendant while conducting it.

	Action	Note
1	 DANGER While conducting the calibration, the robot needs to be connected to power. Make sure that the robot's working area is empty, as the robot can make unpredictable movements.	
2	Wipe the calibration tool clean.  Note The calibration method is exact. Dust, dirt or color flakes will affect the calibration value.	Use a clean cloth.
3	Check if the standard calibration data for axes 4 or 5 are updated with wrist optimization. This is shown in the calibration overview/summary window on the FlexPendant.	If the data is optimized, the calibration routine Wrist Optimization must be re-run after standard calibration. See Calibrating with Wrist Optimization method on page 706 .

Starting the calibration procedure

Use this procedure to start the Axis Calibration routine on the FlexPendant.

	Action	Note
1	Tap the calibration icon and enter the calibration main page.	
2	All mechanical units connected to the system are shown with their calibration status. Tap the mechanical unit in question.  Note For RobotWare 7, the mechanical unit page is displayed only if there is more than one mechanical unit available.	
3	The calibration method used at ABB factory for each axis is shown, as well as calibration method used for the robot during last field calibration.	The FlexPendant will give all information needed to proceed with Axis Calibration.

Continues on next page

5 Calibration

5.4.4 Axis Calibration - Running the calibration procedure

Continued

	Action	Note
4	Valid for RobotWare 6 Tap Call Calibration Method . The software will automatically call for the procedure for the valid calibration method. If not, tap Call Routine and then tap Axis calibration .	
5	Valid for RobotWare 7 Tap Calibration Methods on the right pane and then tap Calibration . The software will automatically call for the procedure for the valid calibration method.	
6	Follow the instructions given on the FlexPendant.	A brief overview of the sequence that will be run on the FlexPendant is given in Overview of the calibration procedure on the FlexPendant on page 700 .

Restarting an interrupted calibration procedure

If the Axis Calibration procedure is interrupted before the calibration is finished, the RobotWare program needs to be started again. Use this procedure to take required action.

Situation	Action
The three-position enabling device on the FlexPendant has been released during robot movement.	Press and hold the three-position enabling device and press Play .
The RobotWare program is terminated with PP to Main .	Remove the calibration tool, if it is installed, and restart the calibration procedure from the beginning. See Starting the calibration procedure . If the calibration tool is in contact the robot axis needs to be jogged in order to release the calibration tool. Jogging the axis in wrong direction will cause the calibration tool to break. Directions of axis movement is shown in Calibration movement directions for all axes on page 689

Axis Calibration with SafeMove option

To be able to run Axis Calibration, SafeMove needs to be unsynchronized. The Axis Calibration routine recognizes if the robot is equipped with SafeMove and will force SafeMove to unsynchronize automatically.

However, SafeMove may generate other warning messages anytime during the Axis Calibration routine. When a warning message is displayed, tap **Acknowledge** to confirm the unsynchronized state and continue Axis Calibration procedure.



CAUTION

SafeMove must be synchronized after the calibration is completed.

Continues on next page

After calibration

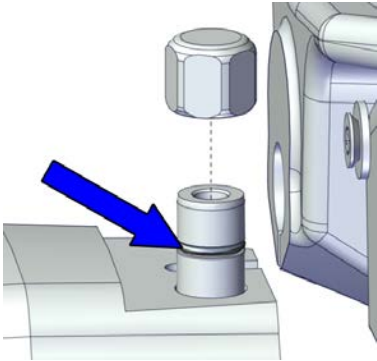
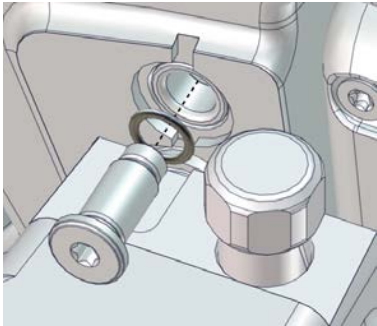
	Action	Note
1	Check the o-ring on the fixed calibration pin. Replace if damaged or missing.	 <p data-bbox="1059 725 1166 745">xx1600002102</p> <p data-bbox="1059 763 1394 815">Protection cover and plug set: 3HAC056806-001.</p>
2	Reinstall the protective cover on the fixed calibration pin on each axis, directly after the axis has been calibrated. Replace the cover with new spare part, if missing or damaged.	
3	Reinstall the protective plug and sealing in the bushing on each axis, directly after the axis has been calibrated. Ensure that the sealing is not damaged. Replace the plug and the sealing with new spare part, if missing or damaged.	 <p data-bbox="1059 1164 1166 1184">xx1500000952</p> <p data-bbox="1059 1202 1394 1254">Protection cover and plug set: 3HAC056806-001.</p>
4	If the standard calibration data for axes 4, 5 or 6 should be updated with wrist optimization, run the calibration routine Wrist Optimization .	See Calibrating with Wrist Optimization method on page 706 .

5.4.5 Reference calibration

Brief introduction to Reference Calibration

Reference calibration is a faster method compared to Fine calibration, as it refers to a previously made calibration.

- 1 Create a backup of the current robot system.
- 2 Check that the active calibration offset values corresponds to the values on the calibration label (located on the lower arm or the base).
- 3 Jog the manipulator so that all axes are in zero position (ex use `MoveAbsJ` instruction). Check that all axis scales are aligned with calibration marks.
- 4 If the scales differ from calibration marks it might depend on wrong turns of the revolution counters. Make a marker line on the corresponding axis to be able to validate the result of the calibration. If more than one motor revolutions are wrong, the calibration will fail.
- 5 Use a verification position. This is especially recommended if all axes were not aligned with the synchronization marks (step 3). Reuse an existing position that is suitable and accurate so it can be used to validate the repair. Use a position where a deviation in axis calibration gives a big deviation in positioning. Note! Check the position after each repair in one axis.
- 6 Use Reference calibration to save reference values for all axes that is to be replaced. Make sure that the values are saved in RobotStudio or FTP program. The files are located in "Active system folder name/HOME/RefCalibFiles".
- 7 Perform the repair.
- 8 Make sure that the tooling and process equipment are the same as when creating the reference. Use Reference calibration to update the system with new calibration offset value for the repaired axis.
- 9 Check the position against the verification position (step 5).
- 10 Proceed with the repair of the next axis, if necessary, and repeat (step 8-9) for every axis.
- 11 (For system containing SafeMove or EPS) Download new calibration values to SafeMove. Use Visual SafeMove in RobotStudio.(For system containing SafeMove) Download new calibration values to SafeMove. Use Visual SafeMove in RobotStudio.
- 12 (For system containing SafeMove or EPS) Synchronize SafeMove to activate SafeMove.(For system containing SafeMove) Synchronize SafeMove to activate SafeMove.
- 13 Perform test run.
- 14 Update the calibration label with new resolver values (calibration values).

Manual tuning of calibration offset

Manual tuning of calibration offset is normally not needed, but can be useful in some situations. The requirement to do manual tuning is that there is a known accurate position, that worked accurately before the repair (step 5, see [Brief introduction to Reference Calibration on page 704](#)).

Continues on next page

Example "Adjust axis 4":

- 1 Create a backup.
- 2 Run the manipulator to the verification position. (The manipulator position is now deviating from the verification position.)
- 3 Read and note current axis 4 value in degrees (example: 96.3 degrees).
- 4 Manually jog, only axis 4, so that the manipulator is correctly positioned to the verification position.
- 5 Read and note current axis 4 value in degrees (example: 94.2 degrees).
- 6 Move the manipulator to its calibration position.
- 7 Calculate the angle difference (ie $96.3 - 94.2 = 2.1$ degrees).
- 8 Manually jog axis 4 the calculated angle difference (-2.1). NOTE! The direction +/- shall be the same direction as the direction used when axis 4 was manually jogged to coincide with the verification process. In the example -2.1 degrees.
- 9 Make a new manual fine calibration of axis 4 with axis in -2.1 degrees position.
- 10 Check again against the verification position.
- 11 Repeat the manual tuning if needed.
- 12 Create a new reference if the intention is to use the reference in the future.

5 Calibration

5.5 Calibrating with Wrist Optimization method

5.5 Calibrating with Wrist Optimization method

When to run Wrist Optimization

Wrist Optimization routine is run to improve TCP reorientation performance.

Calibrating the robot with standard calibration method overwrites the optimized positions of axes 4, 5. Re-run the Wrist Optimization routine after standard calibration to re-achieve the optimized positions of the wrist axes.

Overview of the calibration procedure on the FlexPendant

The actual instructions of how to perform the calibration procedure and what to do at each step is given on the FlexPendant. You will be guided through the calibration procedure, step by step.

Use the following list to learn about the calibration procedure before running the RobotWare program on the FlexPendant. It gives you a brief overview of the calibration procedure sequence.

After the calibration method has been called for on the FlexPendant, the following sequence will be run.

- 1 Choose calibration routine Wrist Optimization.
- 2 Modify targets for 4-point tool frame definition, in Wrist Optimization routine.



Tip

Select positions with large reorientations around the TCP. For best results, make sure that axis 4 and 5 have large movements.

- a Jog the robot to an appropriate position, A, for the first approach point.
Use small increments to accurately position the tool tip as close to the reference point as possible.
- b Tap **Modify Position** to define the point.
- c Repeat for each approach point to be defined, positions B, C, and D.
Jog away from the fixed world point to achieve the best result. Just changing the tool orientation will not give as good a result.

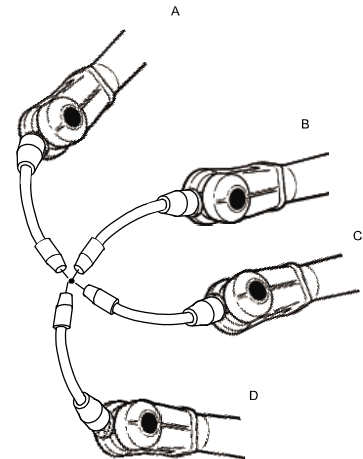

en0400000906

- 3 Improved calibration data to the wrist axes is identified and presented.
- 4 Optimized positions for the wrist axes are presented.

Continues on next page

- 5 The robot moves to the optimized positions for the wrist axes and automatically overwrites previous calibration data.



WARNING

Robot moves automatically when pressing **Calibrate**.

- 6 Wrist optimization is finished.
- 7 Redefine / verify TCP for all tools.

5 Calibration

5.6 Verifying the calibration

5.6 Verifying the calibration

Introduction

Always verify the results after calibrating *any* robot axis to verify that all calibration positions are correct.

Verifying the calibration

Use this procedure to verify the calibration result.

	Action	Note
1	Run the calibration home position program twice. Do not change the position of the robot axes after running the program!	See Checking the synchronization position on page 709 .
2	Adjust the <i>synchronization marks</i> when the calibration is done, if necessary.	This is detailed in section Synchronization marks and synchronization position for axes on page 687 .
3	Write down the values on a new label and stick it on top of the calibration label. The label is located on the lower arm.	

5.7 Checking the synchronization position

Introduction

Check the synchronization position of the robot before beginning any programming of the robot system. This may be done:

- Using a `MoveAbsJ` instruction with argument zero on all axes.
- Using the **Jogging** window on the FlexPendant. Using the **Jog** window on the FlexPendant.

Using a `MoveAbsJ` instruction

Use this procedure to create a program that runs all the robot axes to their synchronization position.

	Action	Note
1	On ABB menu tap Program editor .	
2	Create a new program.	
3	Use MoveAbsJ in the Motion&Proc menu.	
4	Create the following program: <pre>MoveAbsJ [[0,0,0,0,0,0], [9E9,9E9,9E9,9E9,9E9,9E9]] \NoEOffs, v1000, fine, tool0</pre>	
5	Run the program in manual mode.	
6	Check that the synchronization marks for the axes align correctly. If they do not, update the revolution counters.	See Synchronization marks and synchronization position for axes on page 687 and Updating revolution counters on page 690 .

Using the jogging window

Use this procedure to jog the robot to the synchronization position of all axes.

	Action	Note
1	On the ABB menu, tap Jogging .	
2	Tap Motion mode to select group of axes to jog.	
3	Tap to select the axis to jog, axis 1, 2, or 3.	
4	Manually run the robots axes to a position where the axis position value read on the FlexPendant, is equal to zero.	
5	Check that the synchronization marks for the axes align correctly. If they do not, update the revolution counters.	See Synchronization marks and synchronization position for axes on page 687 and Updating revolution counters on page 690 .

Continues on next page

5 Calibration

5.7 Checking the synchronization position

Continued

Using a MoveAbsJ instruction

Use this procedure to create a program that runs all the robot axes to their synchronization position.

	Action	Note
1	Tap Code.	
2	Create a new program.	
3	Use MoveAbsJ in the Add Instruction menu.	
4	Create the following program: <pre>MoveAbsJ [[0,0,0,0,0,0], [9E9,9E9,9E9,9E9,9E9,9E9]] \NoEOfs, v1000, fine, tool0</pre>	
5	Run the program in manual mode.	
6	Check that the synchronization marks for the axes align correctly. If they do not, update the revolution counters.	See Synchronization marks and synchronization position for axes on page 687 and Updating revolution counters on page 690 .

Using the jogging window

Use this procedure to jog the robot to the synchronization position of all axes.

	Action	Note
1	Tap Jog.	
2	From the Mechanical unit list select a mechanical unit.	
3	From the Motion mode section, select an axis-set that need to be jogged. For example, to jog axis 2, select the axis set Axis 1-3 .	
4	Follow the screen instruction on joystick movements to understand the direction of the axis that you want to move and move the joystick.	
5	Manually run the robots axes to a position where the axis position value read on the FlexPendant, is equal to zero.	
6	Check that the synchronization marks for the axes align correctly. If they do not, update the revolution counters.	See Synchronization marks and synchronization position for axes on page 687 and Updating revolution counters on page 690 .

6 Decommissioning

6.1 Introduction to decommissioning

Introduction

This section contains information to consider when taking a product, robot or controller, out of operation.

It deals with how to handle potentially dangerous components and potentially hazardous materials.



Note

The decommissioning process shall be preceded by a risk assessment.

Disposal of materials used in the robot

All used grease/oils and dead batteries **must** be disposed of in accordance with the current legislation of the country in which the robot and the control unit are installed.

If the robot or the control unit is partially or completely disposed of, the various parts **must** be grouped together according to their nature (which is all iron together and all plastic together), and disposed of accordingly. These parts **must** also be disposed of in accordance with the current legislation of the country in which the robot and control unit are installed.

See also [Environmental information on page 712](#).

Transportation

Prepare the robot or parts before transport, this to avoid hazards.

6 Decommissioning

6.2 Environmental information

6.2 Environmental information

Introduction

ABB robots contain components in different materials. During decommissioning, all materials should be dismantled, recycled, or reused responsibly, according to the relevant laws and industrial standards. Robots or parts that can be reused or upcycled helps to reduce the usage of natural resources.

Symbol

The following symbol indicates that the product must not be disposed of as common garbage. Handle each product according to local regulations for the respective content (see table below).

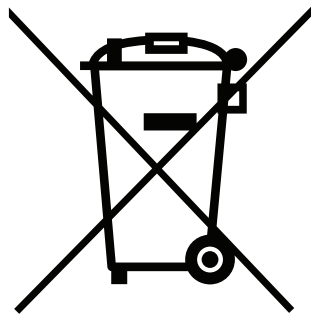

xx1800000058

Materials used in the product

The table specifies some of the materials in the product and their respective use throughout the product.

Dispose components properly according to local regulations to prevent health or environmental hazards.

Material	Example application
Aluminium	Covers, synchronization brackets
Batteries, Lithium	Serial measurement board
Cast iron/nodular iron	Base, lower arm, upper arm
Copper	Cables, motors
Neodymium	Brakes, motors
Oil, grease	Gearboxes
Plastic/rubber	Cables, connectors, drive belts, and so on.
Steel	Gears, screws, base frame, and so on.

Continues on next page

Oil and grease

Where possible, arrange for oil and grease to be recycled. Dispose of via an authorized person/contractor in accordance with local regulations. Do not dispose of oil and grease near lakes, ponds, ditches, down drains, or onto soil. Incineration must be carried out under controlled conditions in accordance with local regulations.

Also note that:

- Spills can form a film on water surfaces causing damage to organisms. Oxygen transfer could also be impaired.
- Spillage can penetrate the soil causing ground water contamination.

6 Decommissioning

6.3 Scrapping of robot

6.3 Scrapping of robot



Note

The decommissioning process shall be preceded by a risk assessment.

Important when scrapping the robot



DANGER

The risk assessment should consider hazards arising in the decommissioning, such as, but not limited to:

- Always remove all batteries. If a battery is exposed to heat, for example from a blow torch, it will explode.
- Always remove all oil/grease in gearboxes. If exposed to heat, for example from a blow torch, the oil/grease will catch fire.
- When motors are removed from the robot, the robot will collapse if it is not properly supported before the motor is removed.
- A used robot does not have the same performance as on delivery. Springs, brakes, bearings, and other parts might be worn or broken.

6.4 Decommissioning of balancing device

General

There is much energy stored in the balancing device. Therefore a special procedure is required to disassemble it. The coil springs inside the balancing device exert a potentially lethal force unless disassembled properly.

The device must be disassembled by a decommissioning company.

Required equipment

Equipment	Article number	Note
Standard toolkit	-	Content is defined in section Standard toolkit on page 724 .
Protective clothing that also covers face and hands	-	Must protect against spatter of sparks and flames.
Cutting torch with a long shaft	-	For opening housing and cutting coils. The long shaft is a safety requirement.
Other tools and procedures may be required. See references to these procedures in the step-by-step instructions below.		These procedures include references to the tools required.



DANGER

Do not, under any circumstances, deal with the balancing device in any other way than that detailed in the product documentation! For example, attempting to open the balancing device is potentially lethal!

Action on field, decommissioning

The procedure below details the actions to perform on field, when the balancing device is to be decommissioned.

	Action	Note
1	Remove the balancing device from the robot.	Detailed in section Replacing the balancing device on page 417 .
2	Secure the piston rod.  CAUTION The piston rod is loose and may slide out when the balancing device is secured.	
3	Send the device to a decommissioning company.	Make sure the decommissioning company is well informed about the stored energy built up by high tensioned compression springs and that the device contains some grease. The following procedure contains useful information about decommissioning.

Continues on next page



6 Decommissioning

6.4 Decommissioning of balancing device

Continued

Decommissioning at decommissioning company, balancing device

The instruction below details how to decommission the balancing device. Contact ABB Robotics for further consultation.

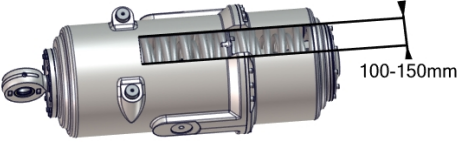
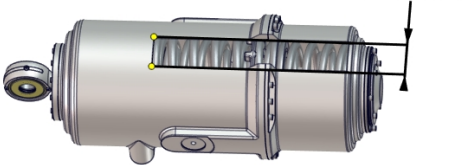
	Action	Note
1	 <p>DANGER</p> <p>There is stored energy built up by high tensioned compression springs inside the balancing device! When a coil is cut the released tension creates a spatter of sparks and flames.</p> <p>The working area must be free of flammable materials. Position the balancing device so that the spatter will be directed away from personnel.</p>	
2	<p>Clamp the device at the working location. Place the device at ground level so that the hole and spring coils are cut from a safe distance and somewhat from above.</p>	
3	 <p>DANGER</p> <p>The hole must be cut as specified in the figure. Pieces of the spring can be thrown out from the cylinder at high speed if the hole is cut larger than specified!</p>	
4	<p>Cut a hole in the housing as shown in the figure.</p>	<p>Use a cutting torch with a long shaft.</p>  <p>xx1600002062</p>
5	<p>Cut all the coils of the springs inside the housing.</p>	<p>Use a cutting torch with a long shaft.</p>
6	<p>Roll the balancing device over and cut an equally large hole on the other side of the device. Then cut all the coils of the springs from that side also.</p>	 <p>xx1600002091</p>
7	<p>Double-check the number of coils cut and make sure all the tension in the springs is removed.</p>	

7 Reference information

7.1 Introduction

General

This chapter includes general information, complementing the more specific information in the different procedures in the manual.

7 Reference information

7.2 Applicable standards

7.2 Applicable standards

General

The product is compliant with ISO 10218-1:2011, *Robots for industrial environments - Safety requirements - Part 1 Robots*, and applicable parts in the normative references, as referred to from ISO 10218-1:2011. In case of deviation from ISO 10218-1:2011, these are listed in the declaration of incorporation. The declaration of incorporation is part of the delivery.

Robot standards

Standard	Description
ISO 9283	Manipulating industrial robots – Performance criteria and related test methods
ISO 9787	Robots and robotic devices – Coordinate systems and motion nomenclatures
ISO 9946	Manipulating industrial robots – Presentation of characteristics

Other standards used in design

Standard	Description
IEC 60204-1	Safety of machinery - Electrical equipment of machines - Part 1: General requirements, normative reference from ISO 10218-1
IEC 61000-6-2	Electromagnetic compatibility (EMC) – Part 6-2: Generic standards – Immunity standard for industrial environments
IEC 61000-6-4	Electromagnetic compatibility (EMC) – Part 6-4: Generic standards – Emission standard for industrial environments
ISO 13849-1:2006	Safety of machinery - Safety related parts of control systems - Part 1: General principles for design, normative reference from ISO 10218-1

Region specific standards and regulations

Standard	Description
ANSI/RIA R15.06	Safety requirements for industrial robots and robot systems
ANSI/UL 1740	Safety standard for robots and robotic equipment
CAN/CSA Z 434-03	Industrial robots and robot Systems - General safety requirements
EN ISO 10218-1	Robots and robotic devices — Safety requirements for industrial robots — Part 1: Robots

7.3 Unit conversion

Converter table

Use the following table to convert units used in this manual.

Quantity	Units		
Length	1 m	3.28 ft.	39.37 in
Weight	1 kg	2.21 lb.	
Weight	1 g	0.035 ounces	
Pressure	1 bar	100 kPa	14.5 psi
Force	1 N	0.225 lbf	
Moment	1 Nm	0.738 lbf-ft	
Volume	1 L	0.264 US gal	

7 Reference information

7.4 Screw joints

7.4 Screw joints

General

This section describes how to tighten the various types of screw joints on ABB robots.

The instructions and torque values are valid for screw joints comprised of metallic materials and do *not* apply to soft or brittle materials.

UNBRAKO screws

UNBRAKO is a special type of screw recommended by ABB for certain screw joints. It features special surface treatment (Gleitmo as described below) and is extremely resistant to fatigue.

Whenever used, this is specified in the instructions, and in such cases, *no other type of replacement screw* is allowed. Using other types of screws will void any warranty and may potentially cause serious damage or injury.

Gleitmo treated screws

Gleitmo is a special surface treatment to reduce the friction when tightening the screw joint. It is recommended by ABB for M6-M20 screw joints. Screws treated with Gleitmo may be reused 3-4 times before the coating disappears. After this the screw must be discarded and replaced with a new one.

When handling screws treated with Gleitmo, protective gloves of nitrile rubber type should be used.

Generally, screws are lubricated with *Gleitmo 603* mixed with *Geomet 500* or *Geomet 702* in proportion 1:3. *Geomet* thickness varies according to screw dimensions, refer to the following.

Dimension	Lubricant	Geomet thickness
M6-M20 (any length except M20x60)	<i>Gleitmo 603 + Geomet 500</i>	3-5 µm
M6-M20 (any length except M20x60)	<i>Gleitmo 603 + Geomet 720</i>	3-5 µm
M20x60	<i>Gleitmo 603 + Geomet 500</i>	8-12 µm
M20x60	<i>Gleitmo 603 + Geomet 720</i>	6-10 µm

Screws lubricated in other ways

Screws lubricated with Molykote 1000 or Molykote P1900 should *only* be used when specified in the repair, maintenance or installation procedure descriptions.

In such cases, proceed as follows:

- 1 Apply lubricant to the screw thread.
- 2 Apply lubricant between the plain washer and screw head.
- 3 Screw dimensions of M8 or larger must be tightened with a torque wrench. Screw dimensions of M6 or smaller may be tightened without a torque wrench *if* this is done by trained and qualified personnel.

Continues on next page

Lubricant	Article number
Molykote 1000 (molybdenum disulphide grease)	3HAC042472-001
Molykote P1900 (molybdenum disulphide grease)	3HAC070875-001

Tightening torque

Before tightening any screw, note the following:

- Determine whether a **standard** tightening torque or **special** torque is to be applied. The **standard torques** are specified in the following tables. Any **special torques** are specified in the repair, maintenance or installation procedure descriptions. **Any special torque specified overrides the standard torque!**
- Use the *correct tightening torque* for each type of screw joint.
- Only use *correctly calibrated* torque keys.
- *Always tighten the joint by hand*, and never use pneumatic tools.
- Use the *correct tightening technique*, that is *do not* jerk. Tighten the screw in a slow, flowing motion.
- Maximum allowed total deviation from the specified value is **10%!**

Tightening torque for oil-lubricated screws with slotted or cross-recess head screws

The following table specifies the recommended standard tightening torque for *oil-lubricated screws with slotted or cross-recess head screws*.



Note

A special torque specified in the repair, maintenance or installation procedure overrides the standard torque.

Tightening torque for oil-lubricated screws with allen head screws

The following table specifies the recommended standard tightening torque for *oil-lubricated screws with allen head screws*.



Note

A special torque specified in the repair, maintenance or installation procedure overrides the standard torque.

Dimension	Tightening torque (Nm)	Tightening torque (Nm)	Tightening torque (Nm)
	Class 8.8, oil-lubricated	Class 10.9, oil-lubricated	Class 12.9, oil-lubricated
M5	6	-	-
M6	10	-	-
M8	24	34	40
M10	47	67	80
M12	82	115	140
M16	200	290	340
M20	400	560	670

Continues on next page

7 Reference information

7.4 Screw joints

Continued

Dimension	Tightening torque (Nm) Class 8.8, oil-lubricated	Tightening torque (Nm) Class 10.9, oil-lubricated	Tightening torque (Nm) Class 12.9, oil-lubricated
M24	680	960	1150

Tightening torque for lubricated screws (Molykote, Gleitmo or equivalent) with allen head screws
The following table specifies the recommended standard tightening torque for *screws lubricated with Molykote 1000, Gleitmo 603 or equivalent with allen head screws.*



Note

A special torque specified in the repair, maintenance or installation procedure overrides the standard torque.

Dimension	Tightening torque (Nm) Class 10.9, lubricated ⁱ	Tightening torque (Nm) Class 12.9, lubricated ⁱ
M5		8
M6		14
M8	28	35
M10	55	70
M12	96	120
M16	235	300
M20	460	550
M24	790	950

ⁱ Lubricated with Molykote 1000, Gleitmo 603 or equivalent

7.5 Weight specifications

Definition

In installation, repair, and maintenance procedures, weights of the components handled are sometimes specified. All components exceeding 22 kg (50 lbs) are highlighted in this way.

To avoid injury, ABB recommends the use of a lifting accessory when handling components with a weight exceeding 22 kg. A wide range of lifting accessories and devices are available for each manipulator model.

Example

Following is an example of a weight specification in a procedure:

Action	Note
 CAUTION The arm weighs 25 kg. All lifting accessories used must be sized accordingly.	

7 Reference information

7.6 Standard toolkit

7.6 Standard toolkit

General

All service (repairs, maintenance, and installation) procedures contains lists of tools required to perform the specified activity.

All special tools required are listed directly in the procedures while all the tools that are considered standard are gathered in the standard toolkit and defined in the following table.

This way, the tools required are the sum of the standard toolkit and any tools listed in the instruction.

Contents, standard toolkit

Qty	Tool	Comment
1	Ring-open-end spanner 8-19 mm	
1	Socket head cap 2.5-17 mm	
1	Torx socket no: 20-60	
1	Box spanner set	
1	Torque wrench 10-100 Nm	
1	Torque wrench 75-400 Nm	
1	Ratchet head for torque wrench 1/2	
2	Hexagon-headed screw M10x100	
1	Hexagon-headed screw M16x90	
1	Hex bit socket head cap no. 14 socket 40 mm L=100 mm	
1	Hex bit socket head cap no. 14 socket 40 mm L=20 mm	To be shortened to 12 mm
1	Hex bit socket head cap no. 6 socket 40 mm L=145 mm	
1	Hex bit socket head cap no. 6 socket 40mm bit L=220 mm	
1	Plastic mallet	

7.7 Special tools

General

All service instructions contain lists of tools required to perform the specified activity. The required tools are a sum of standard tools, defined in the section [Standard toolkit on page 724](#), and of special tools, listed directly in the instructions and also gathered in this section.

Special tools



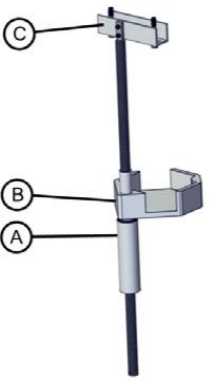

Continues on next page

7 Reference information

7.7 Special tools

Tools and equipment with spare part number: (These tools can be ordered from ABB)		Cable harness	SMB	Brake release unit	Lower arm	Upper arm	Wrist	Turning disk	Balancing device	Spherical roller bearing (link ear)	Rear bearing (balancing device)	Axis 1 motor	Axis 2 motor	Axis 3 motor	Axis 4 motor	Axis 5 motor	Axis 6 motor	Axis 1 gearbox	Axis 2 gearbox	Axis 3 gearbox	Axis 6 gearbox	Hub						
Guide pins																												
3HAC15520-1	Guide pin, M8x100															2												
3HAC15521-2	Guide pin, M10x150											2	2	2	2			2	2	2		2						
3HAC13056-2	Guide pin, M12x150						2												2	2		2						
3HAC13056-3	Guide pin, M12x200																		2									
3HAC13120-2	Guide pin, M16x150				2	2													2	2								
3HAC13120-3	Guide pin, M16x200				2	2													2	2								
Lifting accessories																												
3HAC15556-1	Lifting accessory (chain)				x	x							x	x				x	x	x								
		 xx1200001241																										
3HAC14459-1	Lifting accessory, motor Note! Floor standing robot.											x						x										
3HAC15534-1	Lifting accessory, motor												x	x					x	x								
3HAC062250-001	Removal tool axis-1 motor Note! Inverted robot.											x										x						
		 xx1700000365																										
		<table border="1" style="width: 100%; border-collapse: collapse;"> <tr> <td style="width: 20px; text-align: center;">A</td> <td>Revolving handle</td> </tr> <tr> <td style="width: 20px; text-align: center;">B</td> <td>Shelf</td> </tr> <tr> <td style="width: 20px; text-align: center;">C</td> <td>Bracket</td> </tr> </table>																					A	Revolving handle	B	Shelf	C	Bracket
A	Revolving handle																											
B	Shelf																											
C	Bracket																											
3HAC046128-001	Lifting accessory, gearbox																		x									
3HAC046112-001	Lifting accessory, gearbox																			x								



Continues on next page

Tools and equipment with spare part number: (These tools can be ordered from ABB)			Cable harness	SMB	Brake release unit	Lower arm	Upper arm	Wrist	Turning disk	Balancing device	Spherical roller bearing (link ear)	Rear bearing (balancing device)	Axis 1 motor	Axis 2 motor	Axis 3 motor	Axis 4 motor	Axis 5 motor	Axis 6 motor	Axis 1 gearbox	Axis 2 gearbox	Axis 3 gearbox	Axis 6 gearbox	Hub	
3HAC16131-1	Lifting eye, M12	 xx1200001242				2	2						x		x					2	2	2		x
3HAC14457-4	Lifting eye, M16	 xx1200001242																		2	x	x		
-	Lifting shackle, 2 pcs SA-10-8-NA1	 xx1200001243				x				x	x	x								x	x			
-	Fender washer Outer diameter: minimum 26 mm, maximum 30 mm, hole diameter: 13 mm, thickness: 3 mm.					x	x													x	x	x		
-	Roundsling, 1.5 m Lifting capacity: 2,000 kg.																				x			
-	Roundsling, 1 m Lifting capacity: 1,000 kg.					x		x		x	x	x	x	x	x						x			x
3HAC058825-001	Fork lift accessory set	 xx1700000762				x				x		x								x	x			

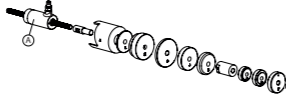

Continues on next page

7 Reference information

7.7 Special tools

Tools and equipment with spare part number: (These tools can be ordered from ABB)			Cable harness	SMB	Brake release unit	Lower arm	Upper arm	Wrist	Turning disk	Balancing device	Spherical roller bearing (link ear)	Rear bearing (balancing device)	Axis 1 motor	Axis 2 motor	Axis 3 motor	Axis 4 motor	Axis 5 motor	Axis 6 motor	Axis 1 gearbox	Axis 2 gearbox	Axis 3 gearbox	Axis 6 gearbox	Hub	
3HAC073537-001	Turning tool or a Fork lift truck with rotator attachment	 xx2100002608				x				x		x								x	x			
Press, puller and unloading tools																								
3HAC028920-001	Dismantle and mounting tool set	 xx1700000383				x				x	x	x									x			
3HAC11731-1	Hydraulic cylinder					x				x	x	x									x			
3HAC13086-1	Hydraulic pump 80 MPa					x				x	x	x									x			
-	Threaded bar, M16x340					x				x		x									x			
Removal tools																								
-	Screws M8x75, fully threaded																						3	
3HAC14631-1	Removal tool motor M12												x	x	x	x	x	x	x	x	x	x		x
3HAC071355-001	Hub tool	 xx2000001378																						x
Other tools																								
-	24 VDC power supply		x			x	x	x					x	x	x	x	x	x	x	x	x	x	x	x
3HAC046645-003	Aligning tool																			x	x			
-	Long Allen key socket IN19L 6-140															x	x	x						
3HAC12342-1	Bits extender												x	x	x		x			x	x	x		x
3HAC055412-001	Calibration tool box, Axis Calibration					x	x	x	x				x	x	x	x	x	x	x	x	x	x	x	x

Continues on next page

Tools and equipment with spare part number: (These tools can be ordered from ABB)		Cable harness	SMB	Brake release unit	Lower arm	Upper arm	Wrist	Turning disk	Balancing device	Spherical roller bearing (link ear)	Rear bearing (balancing device)	Axis 1 motor	Axis 2 motor	Axis 3 motor	Axis 4 motor	Axis 5 motor	Axis 6 motor	Axis 1 gearbox	Axis 2 gearbox	Axis 3 gearbox	Axis 6 gearbox	Hub	
-	Leak-down tester											x	x	x	x	x	x	x	x	x	x	x	x
3HAC058129-001	Relief screws				x				x	x	x								x				
3HAC059728-001 Sleeve 3HAB3409-93 Screw, M16x120 (class 12.9 or 8.8)	Transportation lock screw ⁱ				x				x		x							x	x				
	 xx1600002009																						
-	Lock screw, M16x120 ⁱ												x										
3HAC058167-001	Service stop ⁱ Screws: 3HAB3409-88				x	x			x		x							x	x				
-	Oil collecting vessel												x	x				x	x	x	x		
-	Oil dispenser												x	x				x	x	x	x	x	x
3HAC067545-001	Pinion																				x		
	 xx1800001147																						
3HAB7887-1	Rotation tool				x	x						x	x	x	x	x	x	x	x	x	x	x	x

ⁱ The tools are mounted on the robot at delivery.

Continues on next page

7 Reference information

7.8 Lifting accessories and lifting instructions

7.8 Lifting accessories and lifting instructions

General

Many repair and maintenance activities require different pieces of lifting accessories, which are specified in each procedure.

The use of each piece of lifting accessories is *not* detailed in the activity procedure, but in the instruction delivered with each piece of lifting accessories.

The instructions delivered with the lifting accessories should be stored for later reference.

8 Spare parts

8.1 Spare part lists and illustrations

Location

Spare parts and exploded views are not included in the manual but delivered as a separate document for registered users on myABB Business Portal, www.abb.com/myABB.



Tip

All documents can be found via myABB Business Portal, www.abb.com/myABB.

This page is intentionally left blank

9 Circuit diagrams

9.1 Circuit diagrams

Overview

The circuit diagrams are not included in this manual, but are available for registered users on myABB Business Portal, www.abb.com/myABB.

See the article numbers in the tables below.

Controllers

Product	Article numbers for circuit diagrams
<i>Circuit diagram - OmniCore V250XT</i>	3HAC074000-008
<i>Circuit diagram - IRC5</i>	3HAC024480-011
<i>Circuit diagram - IRC5 Panel Mounted Controller</i>	3HAC026871-020

Manipulators

Product	Article numbers for circuit diagrams
<i>Circuit diagram - IRB 120</i>	3HAC031408-003
<i>Circuit diagram - IRB 140 type C</i>	3HAC6816-3
<i>Circuit diagram - IRB 260</i>	3HAC025611-001
<i>Circuit diagram - IRB 360</i>	3HAC028647-009
<i>Circuit diagram - IRB 390</i>	3HAC060545-009
<i>Circuit diagram - IRB 460</i>	3HAC036446-005
<i>Circuit diagram - IRB 660</i>	3HAC025691-001
<i>Circuit diagram - IRB 760</i>	3HAC025691-001
<i>Circuit diagram - IRB 1200</i>	3HAC046307-003
<i>Circuit diagram - IRB 1410</i>	3HAC2800-3
<i>Circuit diagram - IRB 1600/1660</i>	3HAC021351-003
<i>Circuit diagram - IRB 1520</i>	3HAC039498-007
<i>Circuit diagram - IRB 2400</i>	3HAC6670-3
<i>Circuit diagram - IRB 2600</i>	3HAC029570-007
<i>Circuit diagram - IRB 4400/4450S</i>	3HAC9821-1
<i>Circuit diagram - IRB 4600</i>	3HAC029038-003
<i>Circuit diagram - IRB 6620</i>	3HAC025090-001
<i>Circuit diagram - IRB 6620 / IRB 6620LX</i>	3HAC025090-001
<i>Circuit diagram - IRB 6640</i>	3HAC025744-001
<i>Circuit diagram - IRB 6650S</i>	3HAC13347-1 3HAC025744-001

Continues on next page

9 Circuit diagrams

9.1 Circuit diagrams

Continued

Product	Article numbers for circuit diagrams
<i>Circuit diagram - IRB 6660</i>	<i>3HAC025744-001 3HAC029940-001</i>
<i>Circuit diagram - IRB 6700 / IRB 6790</i>	<i>3HAC043446-005</i>
<i>Circuit diagram - IRB 7600</i>	<i>3HAC13347-1 3HAC025744-001</i>
<i>Circuit diagram - IRB 14000</i>	<i>3HAC050778-003</i>
<i>Circuit diagram - IRB 910SC</i>	<i>3HAC056159-002</i>

Index

A

additional mechanical stop location, 141
 allergenic material, 29
 aluminum
 disposal, 712
 ambient humidity
 operation, 45
 storage, 45
 ambient temperature
 operation, 45
 storage, 45
 assembly instructions, 41
 assessment of hazards and risks, 29
 axis-6
 gearbox
 replacing, 675
 axis-1 gearbox
 replacing, 612
 axis 1
 mechanical stop
 replacing, 458
 motor
 replacing, 461
 axis 2
 motor
 replacing, 475
 axis 3
 gearbox
 replacing, 653
 motor
 replacing, 488
 axis 4
 motor
 replacing, 501
 axis 5
 motor
 replacing, 513
 axis 6
 motor
 replacing, 528
 Axis Calibration, 694
 calibration tool
 article number, 697, 700
 examining, 697
 installation position, 699
 overview of method, 694
 procedure on FlexPendant, 700, 706
 protective cover and protection plug, 699–700

B

balancing device
 inspection, 125
 lubrication of front eye bearing, 182
 replacing, 417
 batteries
 disposal, 712
 battery
 replacing, 179
 battery shutdown
 service routine, 179
 bearing
 balancing device front eye, 182
 brake release, 70
 brake release unit

 replacing, 274
 brakes
 testing function, 37
 BRU
 replacing, 274
 buttons for brake release, 70

C

cabinet lock, 30
 cable harness
 replacing, 217, 240
 cable harness attachments, 129
 cabling, robot, 85
 cabling between robot and controller, 85
 calibrating
 robot, 694
 roughly, 690, 693
 calibrating robot, 694, 706
 calibration
 rough, 690, 693
 standard type, 684
 verification, 708
 when to calibrate, 686
 calibration manuals, 685
 calibration marks, 687
 calibration position
 jogging to, 709–710
 scales, 687
 calibration scales, 687
 carbon dioxide extinguisher, 30
 cast iron
 disposal, 712
 changing oil
 axis 1, 149
 axis 2, 156
 axis 3, 162
 axis 4, 167
 axis 5, 171
 axis 6, 175
 cleaning, 184
 climbing on robot, 33
 Cold environments, 96
 connecting the robot and controller, cabling, 85
 cooling fan, 90
 copper
 disposal, 712

D

damage to additional mechanical stop, 141
 damage to mechanical stop, 140
 dampers
 inspection, 143
 direction of axes, 689

E

environmental information, 712
 equipment, on robot, 73
 ESD
 damage elimination, 54
 sensitive equipment, 54
 expected life, 103

F

fan, 90
 fire extinguishing, 30
 fitting equipment to robot, 73
 FlexPendant

- jogging to calibration position, 709–710
- MoveAbsJ instruction, 709–710
- updating revolution counters, 690, 693

foundation

- requirements, 44

G

gearbox

- axis-6
 - replacing, 675
- axis 3
 - replacing, 653
- inspecting oil level axis 1, 106
- inspecting oil level axis 2, 111
- inspecting oil level axis 3, 113
- inspecting oil level axis 4, 116
- inspecting oil level axis 5, 119
- inspecting oil level axis 6, 122
- oil change axis 1, 149
- oil change axis 2, 156
- oil change axis 3, 162
- oil change axis 4, 167
- oil change axis 5, 171
- oil change axis 6, 175

gearbox axis-1

- replacing, 565

gearboxes

- location of, 148

grease, 33

- disposal, 712

H

hanging

- installed hanging, 29

hazard levels, 19

hazardous material, 712

height

- installed at a height, 29

holes for equipment, 73

hot surfaces, 33

HRA, 29

humidity

- operation, 45
- storage, 45

I

information labels location, 132

inspecting

- additional mechanical stop, 141
- cable harness, 129
- dampers, 143
- information labels, 132
- mechanical stop, 140
- motor seal, 104

inspecting balancing device, 125

inspecting oil levels

- axis 1, 106
- axis 2, 111
- axis 3, 113
- axis 4, 116
- axis 5, 119
- axis 6, 122

installation

- mechanical stop axis 1, 83

installation procedure, 59

installing

- motor cooling fan, 90

instructions for assembly, 41

integrator responsibility, 29

intervals for maintenance, 101

L

labels

- robot, 21

leak-down test, 188

lifting

- lower and upper arm together, 206
- robot, 60, 62
- robot down, 213
- upper arm, 210

lifting accessory, 723

limitation of liability, 17

Lithium

- disposal, 712

loads on foundation, 43

lock and tag, 30

lower arm

- replacing, 343

lubricants, 33

lubricating

- spherical roller bearing, 182

lubrication

- amount in gearboxes, 147
- type of lubrication, 147

M

maintenance intervals, 101

maintenance schedule, 101

manually releasing brakes, 70

mechanical stop

- axis 1, 83
- replacing, 458

mechanical stop location, 140

motor

- axis 1
 - replacing, 461
- axis 2
 - replacing, 475
- axis 3
 - replacing, 488
- axis 4
 - replacing, 501
- axis 5
 - replacing, 513
- axis 6
 - replacing, 528

motor cooling fan, 90

motor seal

- inspecting, 104

MoveAbsJ instruction, 709–710

N

national regulations, 29

negative directions, axes, 689

neodymium

- disposal, 712

nodular iron

- disposal, 712

O

oil, 33

- amount in gearboxes, 147
- disposal, 712
- type of oil, 147

- oil change
 - axis 1, 149
 - axis 2, 156
 - axis 3, 162
 - axis 4, 167
 - axis 5, 171
 - axis 6, 175
- oil level
 - gearbox axis 1, 106
 - gearbox axis 2, 111
 - gearbox axis 3, 113
 - gearbox axis 4, 116
 - gearbox axis 5, 119
 - gearbox axis 6, 122
- operating conditions, 45
- orienting
 - robot, 66
- original spare parts, 17
- P**
- pedestal
 - installed on pedestal, 29
- personnel
 - requirements, 18
- plastic
 - disposal, 712
- positive directions, axes, 689
- PPE, 18
- product standards, 718
- protection classes, 45
- protection type, 45
- protective equipment, 18
- protective wear, 18
- R**
- rear bearings
 - replacing, 441
- recycling, 712
- regional regulations, 29
- release brakes, 36
- replacements, report, 187
- replacing
 - axis-6 gearbox, 675
 - axis-6 motor, 528
 - axis-5 motor, 513
 - axis-4 motor, 501
 - axis-3 gearbox, 653
 - axis-3 motor, 488
 - axis-2 motor, 475
 - axis-1 gearbox, 612
 - axis-1 motor, 461
 - balancing device, 417
 - battery, 179
 - brake release unit, 274
 - cable harness, 217, 240
 - gearbox axis-1, 565
 - lower arm, 343
 - mechanical stop pin, 458
 - rear bearings, 441
 - SMB unit, 268
 - spherical roller bearing, 403
 - the hub, 543
 - turning disc, 336
 - upper arm, 279
 - wrist, 315
 - xx, 61
- report replacements, 187
- requirements on foundation, 44
- responsibility and validity, 17
- restricting
 - working range axis 1, 83
- revolution counters
 - storing on FlexPendant, 690, 693
 - updating, 690, 693
- risk of burns, 33
- risk of tipping, 50
- robot
 - labels, 21
 - lifting, 60, 62
 - lifting down from inverted position, 213
 - protection class, 45
 - protection types, 45
 - symbols, 21
- rotating
 - robot, 66
- roundslings
 - lifting the robot, 62
- rubber
 - disposal, 712
- S**
- safety
 - brake testing, 37
 - ESD, 54
 - fire extinguishing, 30
 - release robot axes, 36
 - signal lamp, 89
 - signals, 19
 - signals in manual, 19
 - symbols, 19
 - symbols on robot, 21
 - test run, 97
- safety devices, 30
- safety equipment
 - mechanical stop, 83
 - signal lamp, 145
- safety hazard
 - hydraulic system, 31
 - pneumatic system, 31
- safety signals
 - in manual, 19
- safety standards, 718
- scales on robot, 687
- schedule of maintenance, 101
- screw joints, 720
- securing
 - robot, 66
 - robot for transportation, 56
- securing the robot to foundation, attachment screws, 67
- serial measurement board
 - replacing, 268
- service stops, 195
- shipping, 711
- signal lamp, 89
- signals
 - safety, 19
- SMB
 - replacing, 268
- SMB battery
 - extension of lifetime, 179
 - replacing, 179
- speed
 - adjusting, 96
- spherical roller bearing

- replacing, 403
- stability, 50
- standards, 718
 - ANSI, 718
 - CAN, 718
- start of robot in cold environments, 96
- steel
 - disposal, 712
- stop pin
 - replacing, 458
- storage conditions, 45
- symbols
 - safety, 19
- synchronization position, 690, 693
- sync marks, 687
- system integrator requirements, 29

T

- taking
 - robot down, 213
- temperatures
 - operation, 45
 - storage, 45
- testing
 - brakes, 37
- the hub
 - replacing, 543
- torques on foundation, 43
- transportation, 711
 - securing the robot, 56
- transportation lock screw, 56
- troubleshooting
 - oil spills, 184
 - safety, 38
- turning disc
 - replacing, 336

U

- upcycling, 712
- updating revolution counters, 690, 693
- upper arm
 - replacing, 279
- users
 - requirements, 18

V

- validity and responsibility, 17
- velocity
 - adjusting, 96
- verifying calibration, 708

W

- weight, 43
 - axis-1 gearbox, 588, 590
 - axis-1 gearbox and base, 586, 594
 - axis-1 motor, 467, 470, 551, 557, 579, 601
 - balancing device, 352, 406, 425, 430, 448, 622
 - robot, 64, 215, 348, 421, 444, 570, 584, 596, 617
 - upper arm, complete, 211, 294, 298, 368, 376, 659, 667
- working range
 - restricting axis 1, 83
- wrist
 - replacing, 315
- Wrist Optimization
 - overview of method, 706

X

- xx
 - replacing, 61

Z

- zero position
 - checking, 709



ABB AB

Robotics & Discrete Automation

S-721 68 VÄSTERÅS, Sweden

Telephone +46 10-732 50 00

ABB AS

Robotics & Discrete Automation

Nordlysvegen 7, N-4340 BRYNE, Norway

Box 265, N-4349 BRYNE, Norway

Telephone: +47 22 87 2000

ABB Engineering (Shanghai) Ltd.

Robotics & Discrete Automation

No. 4528 Kangxin Highway

PuDong New District

SHANGHAI 201319, China

Telephone: +86 21 6105 6666

ABB Inc.

Robotics & Discrete Automation

1250 Brown Road

Auburn Hills, MI 48326

USA

Telephone: +1 248 391 9000

abb.com/robotics