

ROBOTICS

Product manual

IRB 1100



Trace back information:
Workspace 23C version a15
Checked in 2023-10-03
Skribenta version 5.5.019

Product manual
IRB 1100-4/0.475
IRB 1100-4/0.58

OmniCore

Document ID: 3HAC064992-001

Revision: N

The information in this manual is subject to change without notice and should not be construed as a commitment by ABB. ABB assumes no responsibility for any errors that may appear in this manual.

Except as may be expressly stated anywhere in this manual, nothing herein shall be construed as any kind of guarantee or warranty by ABB for losses, damage to persons or property, fitness for a specific purpose or the like.

In no event shall ABB be liable for incidental or consequential damages arising from use of this manual and products described herein.

This manual and parts thereof must not be reproduced or copied without ABB's written permission.

Keep for future reference.

Additional copies of this manual may be obtained from ABB.

Original instructions.

© Copyright 2019-2023 ABB. All rights reserved.
Specifications subject to change without notice.

Table of contents

Overview of this manual	9
Product documentation	13
How to read the product manual	15
1 Safety	17
1.1 Safety information	17
1.1.1 Limitation of liability	17
1.1.2 Requirements on personnel	18
1.2 Safety signals and symbols	19
1.2.1 Safety signals in the manual	19
1.2.2 Safety symbols on manipulator labels	21
1.3 Robot stopping functions	27
1.4 Safety during installation and commissioning	28
1.5 Safety during operation	30
1.6 Safety during maintenance and repair	31
1.6.1 Safety during maintenance and repair	31
1.6.2 Emergency release of the robot axes	34
1.6.3 Brake testing	35
1.7 Safety during troubleshooting	36
1.8 Safety during decommissioning	37
2 Manipulator description	39
2.1 About IRB 1100	39
2.2 Technical data	40
2.3 Dimensions	44
2.4 Working range	46
2.5 The unit is sensitive to ESD	49
3 Installation and commissioning	51
3.1 Introduction to installation and commissioning	51
3.2 Unpacking	52
3.2.1 Pre-installation procedure	52
3.2.2 Risk of tipping/stability	53
3.2.3 Extra O-rings	55
3.2.4 Transportation bracket (3HAC068893-001)	56
3.3 On-site installation	58
3.3.1 Lifting the robot	58
3.3.1.1 Lifting the robot by one person	58
3.3.1.2 Lifting and rotating a suspended mounted robot	60
3.3.2 Orienting and securing the robot	61
3.3.3 Manually releasing the brakes	65
3.3.4 Setting the system parameters for an inverted or a tilted robot	67
3.3.5 Loads fitted to the robot, stopping time and braking distances	72
3.3.6 Fitting equipment on the robot (robot dimensions)	73
3.3.7 Installation of signal lamp (option)	78
3.4 Restricting the working range	80
3.4.1 Adjusting the working range	80
3.4.2 Mechanically restricting the working range	81
3.5 Making robot ready for operation	82
3.5.1 Additional installation procedure, Clean Room	82
3.6 Electrical connection	83
3.6.1 Robot cabling and connection points	83
3.6.2 Customer connections	87
3.7 Start of robot in cold environments	89
3.8 Test run after installation, maintenance, or repair	91

4	Maintenance	93
4.1	Introduction	93
4.2	Maintenance schedule and expected component life	94
4.2.1	Specification of maintenance intervals	94
4.2.2	Maintenance schedule	95
4.2.3	Expected component life	97
4.3	Cleaning activities	98
4.3.1	Cleaning the IRB 1100	98
4.4	Inspection activities	101
4.4.1	Inspecting the information labels	101
4.4.2	Inspecting the robot cabling	103
4.4.3	Inspecting timing belts	104
4.5	Lubricating activities	109
4.5.1	Lubricating the cable package	109
4.6	Replacing/changing activities	111
4.6.1	Replacing the battery pack	111
5	Repair	119
5.1	Introduction	119
5.2	General procedures	120
5.2.1	Mounting instructions for sealings	120
5.2.2	Cut the paint or surface on the robot before replacing parts	124
5.3	Cable harness	126
5.3.1	Replacing the upper cable package	127
5.3.2	Replacing the lower cable package	176
5.3.3	Replacing the SMB unit	217
5.4	Swing and base	226
5.4.1	Replacing the base	226
5.4.2	Replacing the swing	276
5.5	Lower arm	333
5.5.1	Replacing the lower arm	333
5.6	Housing, extender unit and wrist	374
5.6.1	Replacing the housing	374
5.6.2	Replacing the extender unit and wrist	426
5.7	Motors	473
5.7.1	Replacing the axis-1 motor	473
5.7.2	Replacing the axis-2 motor	491
5.7.3	Replacing the axis-3 motor	505
5.7.4	Replacing the axis-4 motor	518
5.7.5	Replacing the axis-5 motor	531
5.7.6	Replacing the axis-6 motor	543
5.8	Gearboxes	555
5.8.1	Replacing the axis-1 gearbox	555
5.8.2	Replacing the axis-2 gearbox	607
5.8.3	Replacing the axis-3 gearbox	630
5.8.4	Replacing the axis-4 gearbox	649
6	Calibration	685
6.1	Introduction to calibration	685
6.1.1	Introduction and calibration terminology	685
6.1.2	Calibration methods	686
6.1.3	When to calibrate	688
6.2	Synchronization marks and axis movement directions	689
6.2.1	Synchronization marks and synchronization position for axes	689
6.2.2	Calibration movement directions for all axes	690
6.3	Updating revolution counters	691
6.3.1	Updating revolution counters on OmniCore robots	691

6.4	Calibrating with Axis Calibration method	695
6.4.1	Description of Axis Calibration	695
6.4.2	Calibration tools for Axis Calibration	698
6.4.3	Installation locations for the calibration tools	700
6.4.4	Axis Calibration - Running the calibration procedure	703
6.4.5	Reference calibration	709
6.5	Calibrating with Wrist Optimization method	711
6.6	Verifying the calibration	713
6.7	Checking the synchronization position	714
7	Troubleshooting	715
7.1	Introduction to troubleshooting	715
7.2	Oil and grease stains on motors and gearboxes	717
7.3	Mechanical noise or dissonance	718
7.4	Manipulator collapses on power down	719
7.5	Motor temperature too high	720
8	Decommissioning	721
8.1	Introduction to decommissioning	721
8.2	Environmental information	722
8.3	Scrapping of robot	724
9	Reference information	725
9.1	Introduction	725
9.2	Applicable standards	726
9.3	Unit conversion	728
9.4	Screw joints	729
9.5	Weight specifications	732
9.6	Standard toolkit	733
9.7	Special tools	734
10	Spare parts	735
10.1	Spare part lists and illustrations	735
Index		737

This page is intentionally left blank

Overview of this manual

About this manual

This manual contains instructions for:

- mechanical and electrical installation of the IRB 1100
- maintenance of the IRB 1100
- mechanical and electrical repair of the IRB 1100

The robot described in this manual has the following protection types:

- *Standard*
 - *IP67*
 - *Clean Room*
-

Usage

This manual should be used during:

- installation and commissioning, from lifting the product to its work site and securing it to the foundation, to making it ready for operation
- maintenance work
- repair work
- decommissioning work



Note

It is the responsibility of the integrator to conduct a risk assessment of the final application.

It is the responsibility of the integrator to provide safety and user guides for the robot system.

Who should read this manual?

This manual is intended for:

- installation personnel
 - maintenance personnel
 - repair personnel.
-

Prerequisites

A maintenance/repair/installation craftsman working with an ABB robot must:

- be trained by ABB and have the required knowledge of mechanical and electrical installation/repair/maintenance work.
 - be trained to respond to emergencies or abnormal situations.
-

Product manual scope

The manual covers all variants and designs of the IRB 1100. Some variants and designs may have been removed from the business offer and are no longer available for purchase.

Continues on next page

References

Documentation referred to in the manual, is listed in the table below.

Document name	Document ID
Product manual, spare parts - IRB 1100	3HAC064994-001
Product specification - IRB 1100	3HAC064993-001
Circuit diagram - IRB 1100	3HAC066314-009
Safety manual for robot - Manipulator and IRC5 or OmniCore controller ⁱ	3HAC031045-001
Product manual - OmniCore C30	3HAC060860-001
Product manual - OmniCore C90XT	3HAC073706-001
Product manual - OmniCore E10	3HAC079399-001
Operating manual - OmniCore	3HAC065036-001
Application manual - Controller software OmniCore	3HAC066554-001
Application manual - CalibWare Field	3HAC030421-001
Technical reference manual - Event logs for RobotWare 7	3HAC066553-001
Technical reference manual - Lubrication in gearboxes	3HAC042927-001
Technical reference manual - System parameters	3HAC065041-001

ⁱ This manual contains all safety instructions from the product manuals for the manipulators and the controllers.

Revisions

Revision	Description
A	First edition.
B	Published in release 20A. The following updates are done in this revision: <ul style="list-style-type: none"> Added information about o-rings on axis-2, -3, and -4 gearboxes. Updated refitting steps of brake release button. Updated the figures of screws that are used to secure the swing to lower arm, the lower arm to housing, the housing to extender unit and the housing to wrist. Added information of resonance sounds in troubleshooting for mechanical noise or dissonance. Clarified text about position of robot and added table with dependencies between axes during Axis Calibration. Clarified and added information in mounting instructions for rotating sealings, see Mounting instructions for sealings on page 120. FlexPendant terminology updated for calibration procedures.
C	Published in release 20B. The following updates are done in this revision: <ul style="list-style-type: none"> Removed spare part O-rings that are on axis-2, -3, and -4 gearboxes because they are not used for protection class IP40. Added instructions of cutting the paint or surface on the robot before replacing parts. Article number of Calibration tool box, Axis Calibration is changed from 3HAC062326-001 to 3HAC074119-001. Installation of signal lamp is updated. Supported controller OmniCore C90XT is added.
D	Published in release 20C. The following updates are done in this revision: <ul style="list-style-type: none"> Protection class IP67 (option 3350-670) and protection type Clean Room (option 3351-4) added.

Continues on next page

Revision	Description
E	<p>Published in release 20D. The following updates are made in this revision:</p> <ul style="list-style-type: none"> • Updated maintenance activity interval for robot overhaul from 40000 hours to 30000 hours. • Updated refitting procedure of axis-4 gearbox. • Updated cleaning method.
F	<p>Published in release 21A. The following updates are made in this revision:</p> <ul style="list-style-type: none"> • Connector types for CP/CS and Ethernet floor cable wiring are added. • Updated spare part article number of axis-1 radial sealing from 3HAB3701-41 to 3HAC070148-005. • Updated diameter value of the air hoses inside the robot.
G	<p>Published in release 21B. The following updates are done in this revision:</p> <ul style="list-style-type: none"> • Text regarding fastener quality is updated, see Fastener quality on page 77. • Text regarding diameter of air hoses is updated, see Customer connections on page 87. • Added maintenance activities of running the <i>Brake Check</i> and <i>Cyclic Brake Check</i> routines. See Maintenance schedule on page 95. • Removed maintenance activity of inspecting oil seepage and updated troubleshooting description about oil and grease stains on motors and gearboxes. • Added a note to remind users that mechanical stop locations cannot be adjusted. See Adjusting the working range on page 80.
H	<p>Published in release 21C. The following updates are done in this revision:</p> <ul style="list-style-type: none"> • Supported controller OmniCore E10 is added. • Added spare part parallel pin on extender unit and updated related refitting procedure of extender unit. • Updated attachment screw information. • Corrected the description of connection point on cabinet. • Updated the naming of timing belt tension adjustment tools, from acoustic tensiometer and tensiometer to sonic tension meter and dynamometer, respectively.
J	<p>Published in release 22A. The following updates are done in this revision:</p> <ul style="list-style-type: none"> • Added information about length of thread engagement for attachment screws. • Added cautions in procedures of removing timing belts, motors and gearboxes. • Updated the article number of grease used for lubricating the radial sealings in replacing procedures. • Removed leak-down test information because it is not available for the robot. • Updated dimension figures to include dimension for bottom connector interface option. • Added troubleshooting for high motor temperature, see Motor temperature too high on page 720. • Updated information about Gleitmo treated screws, see Screw joints on page 729.
K	<p>Published in release 22B. The following updates are done in this revision:</p> <ul style="list-style-type: none"> • Added cleaning instructions for robots with protection type Clean Room. • Updated robot power cable information, see Robot cables on page 83. • Updated the unit of axis-6 working range.

Continues on next page

Overview of this manual

Continued

Revision	Description
L	Published in release 22C. The following updates are done in this revision: <ul style="list-style-type: none">• Updated spare part numbers for axes 1-6 motors.• Added expected life of gearboxes.• Updated information label figure.
M	Published in release 22D. The following updates are done in this revision: <ul style="list-style-type: none">• Added information about Wrist Optimization in calibration chapter.
N	Published in release 23C. The following updates are done in this revision: <ul style="list-style-type: none">• Updated article number of robot signal cable from 3HAC067446-00X to 3HAC084767-00X.

Product documentation

Categories for user documentation from ABB Robotics

The user documentation from ABB Robotics is divided into a number of categories. This listing is based on the type of information in the documents, regardless of whether the products are standard or optional.



Tip

All documents can be found via myABB Business Portal, www.abb.com/myABB.

Product manuals

Manipulators, controllers, DressPack, and most other hardware is delivered with a **Product manual** that generally contains:

- Safety information.
- Installation and commissioning (descriptions of mechanical installation or electrical connections).
- Maintenance (descriptions of all required preventive maintenance procedures including intervals and expected life time of parts).
- Repair (descriptions of all recommended repair procedures including spare parts).
- Calibration.
- Troubleshooting.
- Decommissioning.
- Reference information (safety standards, unit conversions, screw joints, lists of tools).
- Spare parts list with corresponding figures (or references to separate spare parts lists).
- References to circuit diagrams.

Technical reference manuals

The technical reference manuals describe reference information for robotics products, for example lubrication, the RAPID language, and system parameters.

Application manuals

Specific applications (for example software or hardware options) are described in **Application manuals**. An application manual can describe one or several applications.

An application manual generally contains information about:

- The purpose of the application (what it does and when it is useful).
- What is included (for example cables, I/O boards, RAPID instructions, system parameters, software).
- How to install included or required hardware.
- How to use the application.

Continues on next page

- Examples of how to use the application.

Operating manuals

The operating manuals describe hands-on handling of the products. The manuals are aimed at those having first-hand operational contact with the product, that is production cell operators, programmers, and troubleshooters.

How to read the product manual

Reading the procedures

The procedures contain all information required for the installation or service activity and can be printed out separately when needed for a certain service procedure.

Safety information

The manual includes a separate safety chapter that must be read through before proceeding with any service or installation procedures. All procedures also include specific safety information when dangerous steps are to be performed.

Read more in the chapter [Safety on page 17](#).

Illustrations

The product is illustrated with general figures that does not take painting or protection type in consideration.

Likewise, certain work methods or general information that is valid for several product models, can be illustrated with illustrations that show a different product model than the one that is described in the current manual.

This page is intentionally left blank

1 Safety

1.1 Safety information

1.1.1 Limitation of liability

Limitation of liability

Any information given in this manual regarding safety must not be construed as a warranty by ABB that the industrial robot will not cause injury or damage even if all safety instructions are complied with.

The information does not cover how to design, install and operate a robot system, nor does it cover all peripheral equipment that can influence the safety of the robot system.

In particular, liability cannot be accepted if injury or damage has been caused for any of the following reasons:

- Use of the robot in other ways than intended.
- Incorrect operation or maintenance.
- Operation of the robot when the safety devices are defective, not in their intended location or in any other way not working.
- When instructions for operation and maintenance are not followed as intended.
- Non-authorized design modifications of the robot.
- Repairs on the robot and its spare parts carried out by in-experienced or non-qualified personnel.
- Foreign objects.
- Force majeure.

Spare parts and equipment

ABB supplies original spare parts and equipment which have been tested and approved for their intended use. The installation and/or use of non-original spare parts and equipment can negatively affect the safety, function, performance, and structural properties of the robot. ABB is not liable for damages caused by the use of non-original spare parts and equipment.

1 Safety

1.1.2 Requirements on personnel

1.1.2 Requirements on personnel

General

Only personnel with appropriate training are allowed to install, maintain, service, repair, and use the robot. This includes electrical, mechanical, hydraulics, pneumatics, and other hazards identified in the risk assessment.

Persons who are under the influence of alcohol, drugs or any other intoxicating substances are not allowed to install, maintain, service, repair, or use the robot.

The plant liable must make sure that the personnel is trained on the robot, and on responding to emergency or abnormal situations.

Personal protective equipment

Use personal protective equipment, as stated in the instructions.

1.2 Safety signals and symbols

1.2.1 Safety signals in the manual







Introduction to safety signals

This section specifies all safety signals used in the user manuals. Each signal consists of:

- A caption specifying the hazard level (DANGER, WARNING, or CAUTION) and the type of hazard.
- Instruction about how to reduce the hazard to an acceptable level.
- A brief description of remaining hazards, if not adequately reduced.

Hazard levels

The table below defines the captions specifying the hazard levels used throughout this manual.

Symbol	Designation	Significance
	DANGER	Signal word used to indicate an imminently hazardous situation which, if not avoided, will result in serious injury.
	WARNING	Signal word used to indicate a potentially hazardous situation which, if not avoided, could result in serious injury.
	ELECTRICAL SHOCK	Signal word used to indicate a potentially hazardous situation related to electrical hazards which, if not avoided, could result in serious injury.
	CAUTION	Signal word used to indicate a potentially hazardous situation which, if not avoided, could result in slight injury.
	ELECTROSTATIC DISCHARGE (ESD)	Signal word used to indicate a potentially hazardous situation which, if not avoided, could result in severe damage to the product.
	NOTE	Signal word used to indicate important facts and conditions.

Continues on next page

1 Safety

1.2.1 Safety signals in the manual

Continued

Symbol	Designation	Significance
 A yellow lightbulb icon with five short lines radiating from the top, indicating a tip or important information.	TIP	Signal word used to indicate where to find additional information or how to do an operation in an easier way.

1.2.2 Safety symbols on manipulator labels

Introduction to symbols

This section describes safety symbols used on labels (stickers) on the manipulator. Symbols are used in combinations on the labels, describing each specific warning. The descriptions in this section are generic, the labels can contain additional information such as values.



Note

The symbols on the labels on the product must be observed. Additional symbols added by the integrator must also be observed.



Types of symbols

Both the manipulator and the controller are marked with symbols, containing important information about the product. This is important for all personnel handling the robot, for example during installation, service, or operation.

The safety labels are language independent, they only use graphics. See [Symbols on safety labels on page 21](#).

The information labels can contain information in text.

Symbols on safety labels



Symbol	Description
 xx0900000812	Warning! Warns that an accident <i>may</i> occur if the instructions are not followed that can lead to serious injury, possibly fatal, and/or great damage to the product. It applies to warnings that apply to danger with, for example, contact with high voltage electrical units, explosion or fire risk, risk of poisonous gases, risk of crushing, impact, fall from height, etc.
 xx0900000811	Caution! Warns that an accident may occur if the instructions are not followed that can result in injury and/or damage to the product. It also applies to warnings of risks that include burns, eye injury, skin injury, hearing damage, crushing or slipping, tripping, impact, fall from height, etc. Furthermore, it applies to warnings that include function requirements when fitting and removing equipment where there is a risk of damaging the product or causing a breakdown.
 xx0900000839	Prohibition Used in combinations with other symbols.

Continues on next page

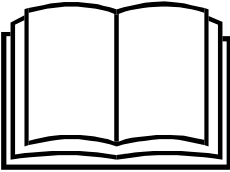
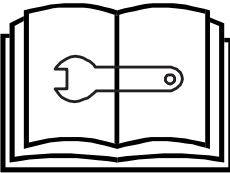
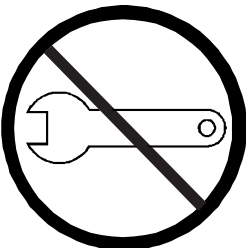
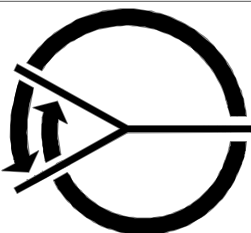

1 Safety

1.2.2 Safety symbols on manipulator labels

Continued

Symbol	Description
 xx0900000813	See user documentation Read user documentation for details. Which manual to read is defined by the symbol: <ul style="list-style-type: none">No text: <i>Product manual</i>.
 xx0900000816	Before disassembly, see product manual
 xx0900000815	Do not disassemble Disassembling this part can cause injury.
 xx0900000814	Extended rotation This axis has extended rotation (working area) compared to standard.
 xx0900000808	Brake release Pressing this button will release the brakes. This means that the robot arm can fall down.

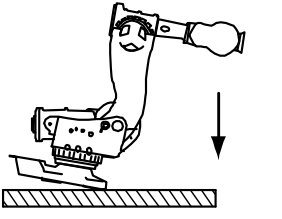

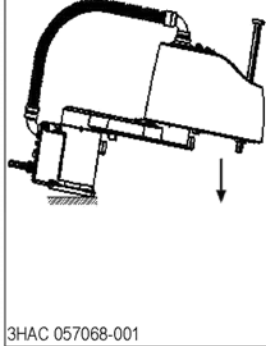
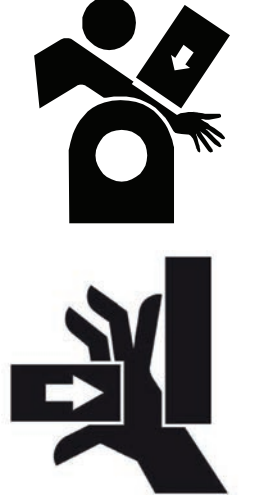
Continues on next page

Symbol	Description
 <p>xx0900000810</p>   <p>3HAC 057068-001</p> <p>xx1500002402</p>	<p>Tip risk when loosening bolts The robot can tip over if the bolts are not securely fastened.</p>
 <p>xx0900000817</p>	<p>Crush Risk of crush injuries.</p>





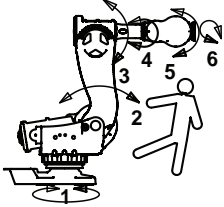
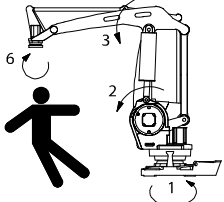
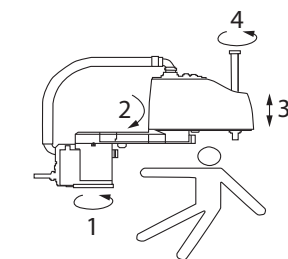

1 Safety

1.2.2 Safety symbols on manipulator labels

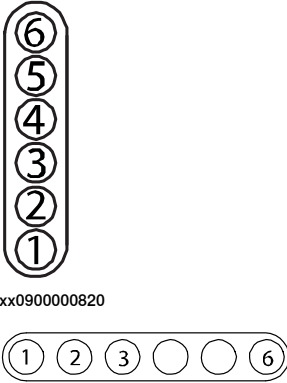
Continued

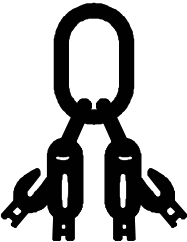
Symbol	Description
 xx0900000818  xx1300001087	Heat Risk of heat that can cause burns. (Both signs are used)
 xx0900000819  xx1000001141  xx1500002616	Moving robot The robot can move unexpectedly.

Continues on next page





Symbol	Description
 <p>xx0900000820</p> <p>xx1000001140</p>	<p>Brake release buttons</p>
 <p>xx0900000821</p>	<p>Lifting bolt</p>
 <p>xx1000001242</p>	<p>Adjustable chain sling with shortener</p>
 <p>xx0900000822</p>	<p>Lifting of robot</p>
 <p>xx0900000823</p>	<p>Oil Can be used in combination with prohibition if oil is not allowed.</p>
 <p>xx0900000824</p>	<p>Mechanical stop</p>

Continues on next page

1 Safety

1.2.2 Safety symbols on manipulator labels

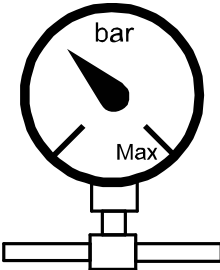
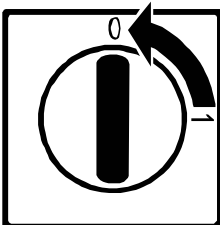
Continued

Symbol	Description
 xx1000001144	No mechanical stop
 xx0900000825	Stored energy Warns that this part contains stored energy. Used in combination with <i>Do not disassemble</i> symbol.
 xx0900000826	Pressure Warns that this part is pressurized. Usually contains additional text with the pressure level.
 xx0900000827	Shut off with handle Use the power switch on the controller.
 xx1400002648	Do not step Warns that stepping on these parts can cause damage to the parts.

1.3 Robot stopping functions

Protective stop and emergency stop

The protective stops and emergency stops are described in the product manual for the controller.

For more information see:

- *Product manual - OmniCore C30*
- *Product manual - OmniCore C90XT*
- *Product manual - OmniCore E10*

1 Safety

1.4 Safety during installation and commissioning

1.4 Safety during installation and commissioning

National or regional regulations

The integrator of the robot system is responsible for the safety of the robot system.

The integrator is responsible that the robot system is designed and installed in accordance with the safety requirements set forth in the applicable national and regional standards and regulations.

The integrator of the robot system is required to perform a risk assessment.

Layout

The robot integrated to a robot system shall be designed to allow safe access to all spaces during installation, operation, maintenance, and repair.

If robot movement can be initiated from an external control panel then an emergency stop must also be available.

If the manipulator is delivered with mechanical stops, these can be used for reducing the working space.

A perimeter safeguarding, for example a fence, shall be dimensioned to withstand the following:

- The force of the manipulator.
- The force of the load handled by the robot if dropped or released at maximum speed.
- The maximum possible impact caused by a breaking or malfunctioning rotating tool or other device fitted to the robot.

The maximum TCP speed and the maximum velocity of the robot axes are detailed in the section *Robot motion* in the product specification for the respective manipulator.

Consider exposure to hazards, such as slipping, tripping, and falling.

Hazards due to the working position and posture for a person working with or near the robot shall be considered.

Hazards due to noise emission from the robot needs to be considered.

Consider hazards from other equipment in the robot system, for example, that guards remain active until identified hazards are reduced to an acceptable level.

Allergenic material

See [Environmental information on page 722](#) for specification of allergenic materials in the product, if any.

Securing the robot to the foundation

The robot must be properly fixed to its foundation/support, as described in the respective product manual.

When the robot is installed at a height, hanging, or other than mounted directly on the floor, there will be additional hazards.

Continues on next page

Electrical safety

Incoming mains must be installed to fulfill national regulations.

The power supply wiring to the robot must be sufficiently fused and if necessary, it must be possible to disconnect it manually from the mains power.

The power to the robot must be turned off with the main switch and the mains power disconnected when performing work inside the controller cabinet. Lock and tag shall be considered.

Harnesses between controller and manipulator shall be fixed and protected to avoid tripping and wear.

Wherever possible, power on/off or rebooting the robot controller shall be performed with all persons outside the safeguarded space.



Note

Use a CARBON DIOXIDE (CO₂) extinguisher in the event of a fire in the robot.

Safety devices

The integrator is responsible for that the safety devices necessary to protect people working with the robot system are designed and installed correctly.

When integrating the robot with external devices to a robot system:

- The integrator of the robot system must ensure that emergency stop functions are interlocked in accordance with applicable standards.
- The integrator of the robot system must ensure that safety functions are interlocked in accordance with applicable standards.

Other hazards

A robot may perform unexpected limited movement.



WARNING

Manipulator movements can cause serious injuries on users and may damage equipment.

The risk assessment should also consider other hazards arising from the application, such as, but not limited to:

- Water
- Compressed air
- Hydraulics

End-effector hazards require particular attention for applications which involve close human collaboration with the robot.

Verify the safety functions

Before the robot system is put into operation, verify that the safety functions are working as intended and that any remaining hazards identified in the risk assessment are mitigated to an acceptable level.

1 Safety

1.5 Safety during operation

1.5 Safety during operation

Automatic operation

Verify the application in the operating mode manual reduced speed, before changing mode to automatic and initiating automatic operation.

Unexpected movement of robot arm



WARNING

Hazards due to the use of brake release devices and/or gravity beneath the manipulator shall be considered.

A robot may perform unexpected limited movement.



WARNING

Manipulator movements can cause serious injuries on users and may damage equipment.

1.6 Safety during maintenance and repair

1.6.1 Safety during maintenance and repair

General

Corrective maintenance must only be carried out by personnel trained on the robot. Maintenance or repair must be done with all electrical, pneumatic, and hydraulic power switched off, that is, no remaining hazards.

Hazards due to stored mechanical energy in the manipulator for the purpose of counterbalancing axes must be considered before maintenance or repair.

Never use the robot as a ladder, which means, do not climb on the controller, manipulator, including motors, or other parts. There are hazards of slipping and falling. The robot might be damaged.

Make sure that there are no tools, loose screws, turnings, or other unexpected parts remaining after maintenance or repair work.

When the work is completed, verify that the safety functions are working as intended.

Hot surfaces

Surfaces can be hot after running the robot, and touching these may result in burns. Allow the surfaces to cool down before maintenance or repair.

Allergic reaction

Warning	Description	Elimination/Action
 Allergic reaction	When working with lubricants there is a risk of an allergic reaction.	Make sure that protective gear like goggles and gloves are always worn.

Gearbox lubricants (oil or grease)

When handling oil, grease, or other chemical substances the safety information of the respective manufacturer must be observed.



Note

Take special care when handling hot lubricants.





Warning	Description	Elimination/Action
 Hot oil or grease	Changing and draining gearbox oil or grease may require handling hot lubricant heated up to 90 °C.	Make sure that protective gear like goggles and gloves are always worn during this activity.

Continues on next page

1 Safety

1.6.1 Safety during maintenance and repair

Continued

Warning	Description	Elimination/Action
 Allergic reaction	When working with lubricants there is a risk of an allergic reaction.	Make sure that protective gear like goggles and gloves are always worn.
 Possible pressure build-up in gearbox	When opening the oil or grease plug, there may be pressure present in the gearbox, causing lubricant to spray from the opening.	Open the plug carefully and keep away from the opening. Do not overfill the gearbox when filling.
 Do not overfill	Overfilling of gearbox lubricant can lead to internal over-pressure inside the gearbox which in turn may: <ul style="list-style-type: none"> • damage seals and gaskets • completely press out seals and gaskets • prevent the robot from moving freely. 	Make sure not to overfill the gearbox when filling it with oil or grease. After filling, verify that the level is correct.
 Specified amount depends on drained volume	The specified amount of oil or grease is based on the total volume of the gearbox. When changing the lubricant, the amount refilled may differ from the specified amount, depending on how much has previously been drained from the gearbox.	After filling, verify that the level is correct.

Hazards related to batteries

Under rated conditions, the electrode materials and liquid electrolyte in the batteries are sealed and not exposed to the outside.

There is a hazard in case of abuse (mechanical, thermal, electrical) which leads to the activation of safety valves and/or the rupture of the battery container. As a result under certain circumstances, electrolyte leakage, electrode materials reaction with moisture/water or battery vent/explosion/fire may follow.

Do not short circuit, recharge, puncture, incinerate, crush, immerse, force discharge or expose to temperatures above the declared operating temperature range of the product. Risk of fire or explosion.

Operating temperatures are listed in [Operating conditions, robot on page 43](#).

See safety instructions for the batteries in *Material/product safety data sheet - Battery pack (3HAC043118-001)*.

Unexpected movement of robot arm



WARNING

Hazards due to the use of brake release devices and/or gravity beneath the manipulator shall be considered.

Continues on next page

A robot may perform unexpected limited movement.



WARNING

Manipulator movements can cause serious injuries on users and may damage equipment.

Related information

See also the safety information related to installation and operation.

1 Safety

1.6.2 Emergency release of the robot axes

1.6.2 Emergency release of the robot axes

Description

In an emergency situation, the brakes on a robot axis can be released manually by pushing a brake release button.

How to release the brakes is described in the section:

- [Manually releasing the brakes on page 65](#).

The robot may be moved manually on smaller robot models, but larger models may require using an overhead crane or similar equipment.

Increased injury

Before releasing the brakes, make sure that the weight of the manipulator does not result in additional hazards, for example, even more severe injuries on a trapped person.



DANGER

When releasing the holding brakes, the robot axes may move very quickly and sometimes in unexpected ways.

Make sure no personnel is near or beneath the robot.

1.6.3 Brake testing

When to test

During operation, the holding brake of each axis normally wears down. A test can be performed to determine whether the brake can still perform its function.

How to test

The function of the holding brake of each axis motor may be verified as described below:

- 1 Run each axis to a position where the combined weight of the manipulator and any load is maximized (maximum static load).
- 2 Switch the motor to the MOTORS OFF.
- 3 Inspect and verify that the axis maintains its position.

If the manipulator does not change position as the motors are switched off, then the brake function is adequate.



Note

It is recommended to run the service routine *BrakeCheck* as part of the regular maintenance, see the operating manual for the robot controller.

For robots with the option SafeMove, the *Cyclic Brake Check* routine is recommended. See the manual for SafeMove in [References on page 10](#).

1 Safety

1.7 Safety during troubleshooting

1.7 Safety during troubleshooting

General

When troubleshooting requires work with power switched on, special considerations must be taken:

- Safety circuits might be muted or disconnected.
- Electrical parts must be considered as *live*.
- The manipulator can move unexpectedly at any time.



DANGER

Troubleshooting on the controller while powered on must be performed by personnel trained by ABB or by ABB field engineers.

A risk assessment must be done to address both robot and robot system specific hazards.



WARNING

Hazards due to the use of brake release devices and/or gravity beneath the manipulator shall be considered.

A robot may perform unexpected limited movement.



WARNING

Manipulator movements can cause serious injuries on users and may damage equipment.

Related information

See also the safety information related to installation, operation, maintenance, and repair.

1.8 Safety during decommissioning

General

See section [Decommissioning on page 721](#).

If the robot is decommissioned for storage, take extra precaution to reset safety devices to delivery status.

Unexpected movement of robot arm



WARNING

Hazards due to the use of brake release devices and/or gravity beneath the manipulator shall be considered.

A robot may perform unexpected limited movement.



WARNING

Manipulator movements can cause serious injuries on users and may damage equipment.

This page is intentionally left blank

2 Manipulator description

2.1 About IRB 1100

Introduction

The IRB 1100 is one of ABB Robotics latest generation of 6-axis industrial robot, with a payload of 4 kg, designed specifically for manufacturing industries that use flexible robot-based automation, e.g. 3C industry. The robot has an open structure that is especially adapted for flexible use, and can communicate extensively with external systems.

2 Manipulator description

2.2 Technical data

2.2 Technical data

Weight, robot

The table shows the weight of the robot.

Robot model	Nominal weight
IRB 1100	21.1 kg



Note

The weight does not include additional options, tools and other equipment fitted on the robot.

Mounting positions

The table shows valid mounting positions and the installation (mounting) angle for the manipulator.

Mounting position	Installation angle
Floor mounted	Any angle
Wall mounted	Any angle
Suspended	Any angle



Note

The actual mounting angle must always be configured in the system parameters, otherwise the performance and lifetime is affected. See [Setting the system parameters for an inverted or a tilted robot on page 67](#).

Loads on foundation, robot

The illustration shows the directions of the robots stress forces.

Continues on next page

The directions are valid for all floor mounted, table mounted, wall mounted and suspended robots.

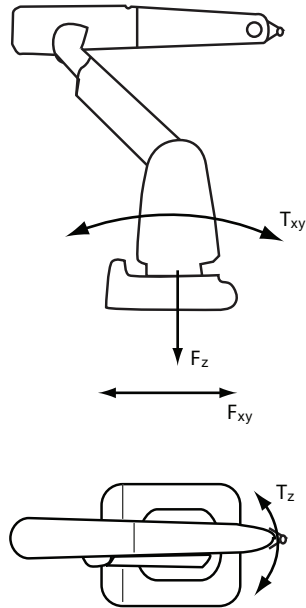

xx110000521

F_{xy}	Force in any direction in the XY plane
F_z	Force in the Z plane
T_{xy}	Bending torque in any direction in the XY plane
T_z	Bending torque in the Z plane

The table shows the various forces and torques working on the robot during different kinds of operation.



Note

These forces and torques are extreme values that are rarely encountered during operation. The values also never reach their maximum at the same time!



WARNING

The robot installation is restricted to the mounting options given in following load table(s).

Floor mounted

Force	Endurance load (in operation)	Maximum load (emergency stop)
Force xy	±420 N	±710N
Force z	+210 ±380 N	+210 ±510 N
Torque xy	±180 Nm	±330 Nm
Torque z	±90 Nm	±140 Nm

Continues on next page

2 Manipulator description

2.2 Technical data

Continued

Wall mounted

Force	Endurance load (in operation)	Max. load (emergency stop)
Force xy	+210 ±370 N	+210 ±660 N
Force z	±370 N	±540 Nm
Torque xy	±200 Nm	±370Nm
Torque z	±90 Nm	±140 Nm

Suspended

Force	Endurance load (in operation)	Max. load (emergency stop)
Force xy	±420 N	±710 N
Force z	-210 ±380 N	-210 ±510 N
Torque xy	±180 Nm	±330 Nm
Torque z	±90 Nm	±140 Nm

Requirements, foundation

The table shows the requirements for the foundation where the weight of the installed robot is included:

Requirement	Value	Note
Flatness of foundation surface	0.1/500 mm	Flat foundations give better repeatability of the resolver calibration compared to original settings on delivery from ABB. The value for levelness aims at the circumstance of the anchoring points in the robot base. In order to compensate for an uneven surface, the robot can be recalibrated during installation. If resolver/encoder calibration is changed this will influence the absolute accuracy.
Minimum resonance frequency	22 Hz  Note It may affect the manipulator lifetime to have a lower resonance frequency than recommended.	The value is recommended for optimal performance. Due to foundation stiffness, consider robot mass including equipment. ⁱ For information about compensating for foundation flexibility, see the description of <i>Motion Process Mode</i> in the manual that describes the controller software option, see References on page 10 .
Minimum foundation material yield strength	150 MPa	

ⁱ The minimum resonance frequency given should be interpreted as the frequency of the robot mass/inertia, robot assumed stiff, when a foundation translational/torsional elasticity is added, i.e., the stiffness of the pedestal where the robot is mounted. The minimum resonance frequency should not be interpreted as the resonance frequency of the building, floor etc. For example, if the equivalent mass of the floor is very high, it will not affect robot movement, even if the frequency is well below the stated frequency. The robot should be mounted as rigid as possible to the floor.

Disturbances from other machinery will affect the robot and the tool accuracy. The robot has resonance frequencies in the region 10 – 20 Hz and disturbances in this region will be amplified, although somewhat damped by the servo control. This might be a problem, depending on the requirements from the applications. If this is a problem, the robot needs to be isolated from the environment.

Continues on next page

Storage conditions, robot

The table shows the allowed storage conditions for the robot:

Parameter	Value
Minimum ambient temperature	-25 °C (-13 °F)
Maximum ambient temperature	+55 °C (+131 °F)
Maximum ambient temperature (less than 24 hrs)	+70 °C (+158 °F)
Maximum ambient humidity	95% at constant temperature (gaseous only)

Operating conditions, robot

The table shows the allowed operating conditions for the robot:

Parameter	Value
Minimum ambient temperature	+5 °C ⁱ (41 °F)
Maximum ambient temperature	+45 °C (113 °F)
Maximum ambient humidity	95% at constant temperature

ⁱ At low environmental temperature (below 10° C) a warm-up phase is recommended to be run with the robot. Otherwise there is a risk that the robot stops or runs with lower performance due to temperature dependent oil and grease viscosity.

Protection classes, robot

The table shows the available protection types of the robot, with the corresponding protection class.

Protection type	Protection class ⁱ
Manipulator, protection type Standard	IP40 IP67 (option 3350-670)
Manipulator, protection type Clean Room	ISO 4

ⁱ According to IEC 60529.

Environmental information

The product complies with IEC 63000. *Technical documentation for the assessment of electrical and electronic products with respect to the restriction of hazardous substances.*

2 Manipulator description

2.3 Dimensions

2.3 Dimensions

Main dimensions of IRB 1100-4/0.475

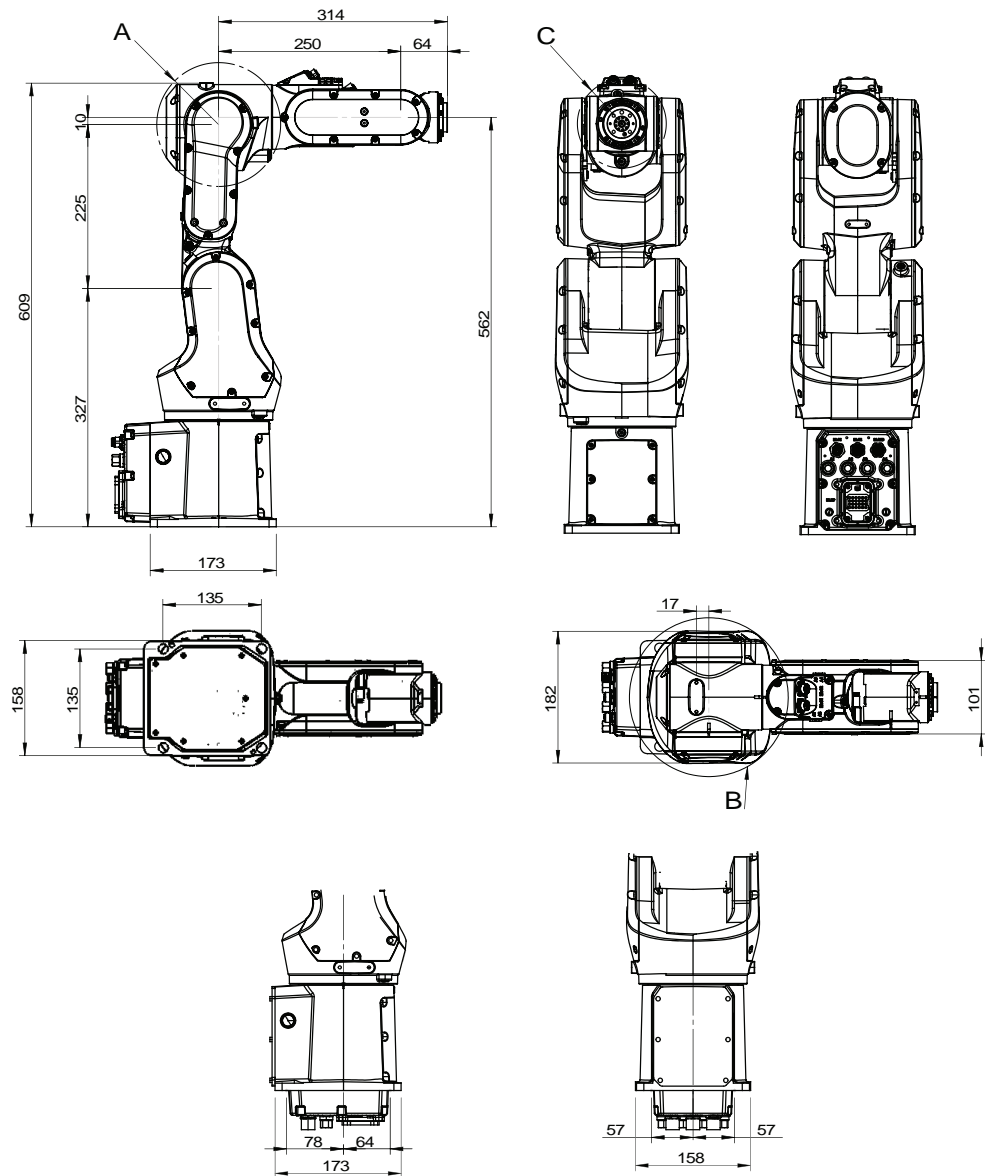

xx1800002606

Pos	Description
A	Turning radius: R85
B	Turning radius: R109
C	Turning radius: R61

Continues on next page

Main dimensions of IRB 1100-4/0.58

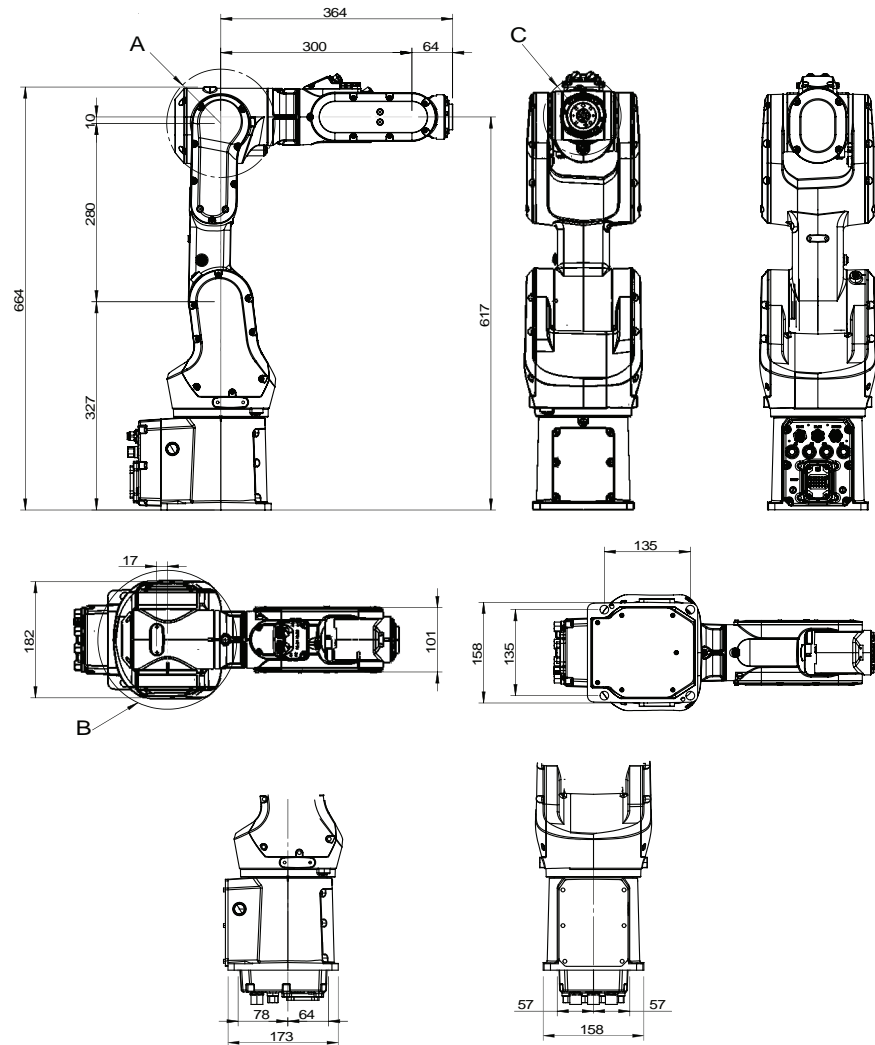

xx1800002607

Pos	Description
A	Turning radius: R85
B	Turning radius: R109
C	Turning radius: R61

2 Manipulator description

2.4 Working range

2.4 Working range

Illustration, working range IRB 1100-4/0.475

This illustration shows the unrestricted working range of the robot.

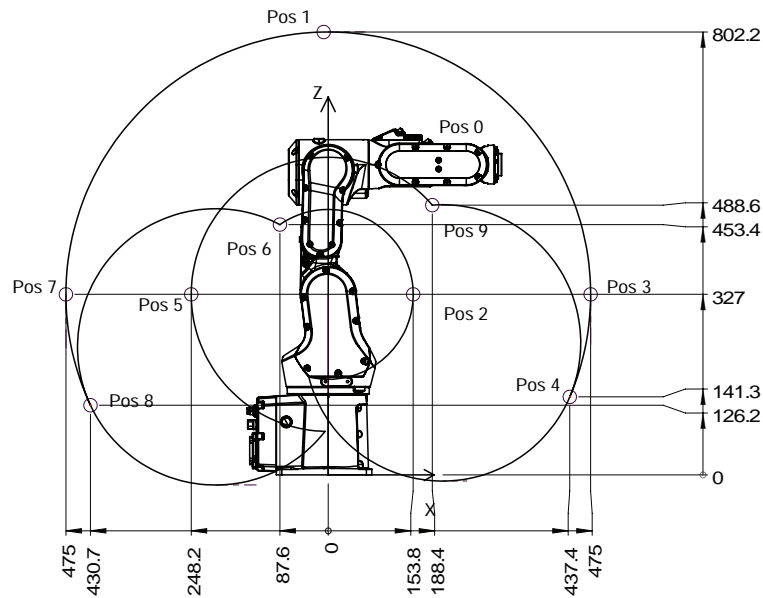

xx1800002437

Positions at wrist center and angle of axes 2 and 3

Position in the figure	Positions at wrist center (mm)		Angle (degrees)	
	X	Z	axis 2	axis 3
pos0	314	562	0°	0°
pos1	0	802	0°	-87.7°
pos2	53.8	327	9.7°	55°
pos3	475	327	90°	-87.7°
pos4	437.4	141.3	113°	-87.7°
pos5	-248.2	327	-26.4°	-205°
pos6	-87.6	453.4	-115°	55°
pos7	-475	327	-90°	-87.7°
pos8	-430.7	126.2	-115°	-87.7°
pos9	188.4	488.6	113°	-205°

Continues on next page

Illustration, working range IRB 1100-4/0.58

This illustration shows the unrestricted working range of the robot.

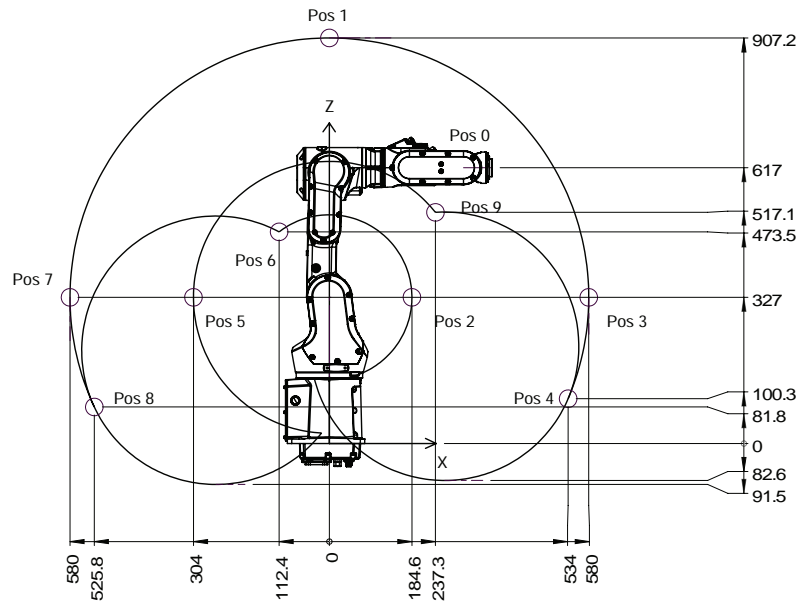

xx1800002438

Positions at wrist center and angle of axes 2 and 3

Position in the figure	Positions at wrist center (mm)		Angle (degrees)	
	X	Z	axis 2	axis 3
pos0	364	617	0°	0°
pos1	0	907.2	0°	-88°
pos2	184.6	327	12.5°	55°
pos3	580	327	90°	-88°
pos4	534	100.3	113°	-88°
pos5	-304	327	-28.3°	-205°
pos6	-112.4	473.5	-115°	55°
pos7	-580	327	-90°	-88°
pos8	-525.8	81.8	-115°	-88°
pos9	237.3	517.1	113°	-205°

Continues on next page

2 Manipulator description

2.4 Working range

Continued

Top view of working range

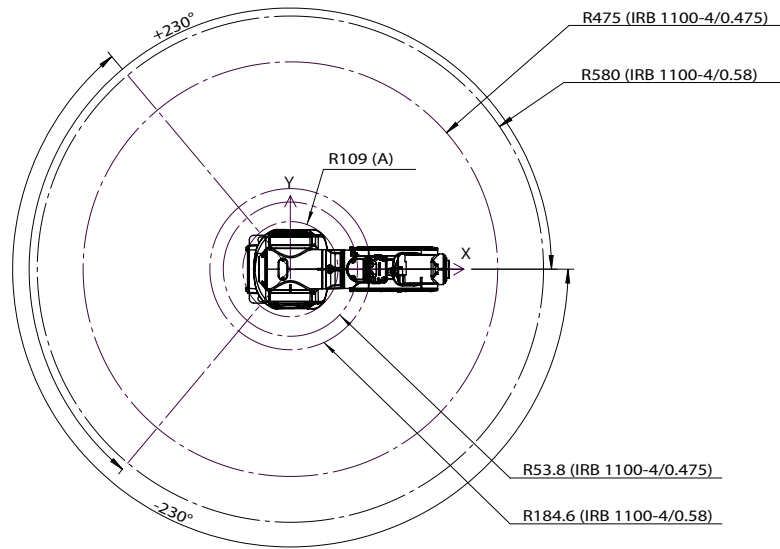

xx1800002439

Working range

Axis	Working range	Note
Axis 1	$\pm 230^\circ$	Wall mounted robot has a work area for axis 1 that depends on payload and the positions of other axes. Simulation in RobotStudio is recommended.
Axis 2	$-115^\circ / +113^\circ$	
Axis 3	$-205^\circ / +55^\circ$	
Axis 4	$\pm 230^\circ$	
Axis 5	$-125^\circ / +120^\circ$	
Axis 6	$\pm 400^\circ$	Default value.
	± 242	Maximum revolution value. The default working range for axis 6 can be extended by changing parameter values in the software.

2.5 The unit is sensitive to ESD

Description

ESD (electrostatic discharge) is the transfer of electrical static charge between two bodies at different potentials, either through direct contact or through an induced electrical field. When handling parts or their containers, personnel not grounded may potentially transfer high static charges. This discharge may destroy sensitive electronics.

Safe handling

Use one of the following alternatives:

- Use a wrist strap.

Wrist straps must be tested frequently to ensure that they are not damaged and are operating correctly.

- Use an ESD protective floor mat.

The mat must be grounded through a current-limiting resistor.

- Use a dissipative table mat.

The mat should provide a controlled discharge of static voltages and must be grounded.

This page is intentionally left blank

3 Installation and commissioning

3.1 Introduction to installation and commissioning

General

This chapter contains assembly instructions and information for installing the IRB 1100 at the working site.

See also the product manual for the robot controller.

The installation must be done by qualified installation personnel in accordance with the safety requirements set forth in the applicable national and regional standards and regulations.

The technical data is detailed in section [Technical data on page 40](#).

Safety information

Before any installation work is commenced, all safety information must be observed. There are general safety aspects that must be read through, as well as more specific safety information that describes the danger and safety risks when performing the procedures. Read the chapter [Safety on page 17](#) before performing any installation work.



Note

Always connect the IRB 1100 and the robot to protective earth and residual current device (RCD) before connecting to power and starting any installation work.

For more information see:

- *Product manual - OmniCore C30*
- *Product manual - OmniCore C90XT*
- *Product manual - OmniCore E10*

3 Installation and commissioning

3.2.1 Pre-installation procedure

3.2 Unpacking

3.2.1 Pre-installation procedure

Introduction

This section is intended for use when unpacking and installing the robot for the first time. It also contains information useful during later re-installation of the robot.

Prerequisites for installation personnel

Installation personnel working with an ABB product must:

- Be trained by ABB and have the required knowledge of mechanical and electrical installation/maintenance/repair work.
- Conform to all national and local codes.

Checking the pre-requisites for installation

	Action
1	Make a visual inspection of the packaging and make sure that nothing is damaged.
2	Remove the packaging.
3	Check for any visible transport damage.  Note Stop unpacking and contact ABB if transport damages are found.
4	Clean the unit with a lint-free cloth, if necessary.
5	Make sure that the lifting accessory used (if required) is suitable to handle the weight of the robot as specified in: Weight, robot on page 40
6	If the robot is not installed directly, it must be stored as described in: Storage conditions, robot on page 43
7	Make sure that the expected operating environment of the robot conforms to the specifications as described in: Operating conditions, robot on page 43
8	Before taking the robot to its installation site, make sure that the site conforms to: <ul style="list-style-type: none">• Loads on foundation, robot on page 40• Protection classes, robot on page 43• Requirements, foundation on page 42
9	Before moving the robot, please observe the stability of the robot: Risk of tipping/stability on page 53
10	When these prerequisites are met, the robot can be taken to its installation site as described in section: On-site installation on page 58
11	Install required equipment, if any.

3.2.2 Risk of tipping/stability

Risk of tipping

If the robot is not fastened to the foundation while moving the arm, the robot is not stable in the whole working area. Moving the arm will displace the center of gravity, which may cause the robot to tip over.

The transportation position is the most stable position.

Do not change the robot position before securing it to the foundation!

Transportation position

This figure shows the robot in its transportation position.

IRB 1100-4/0.475

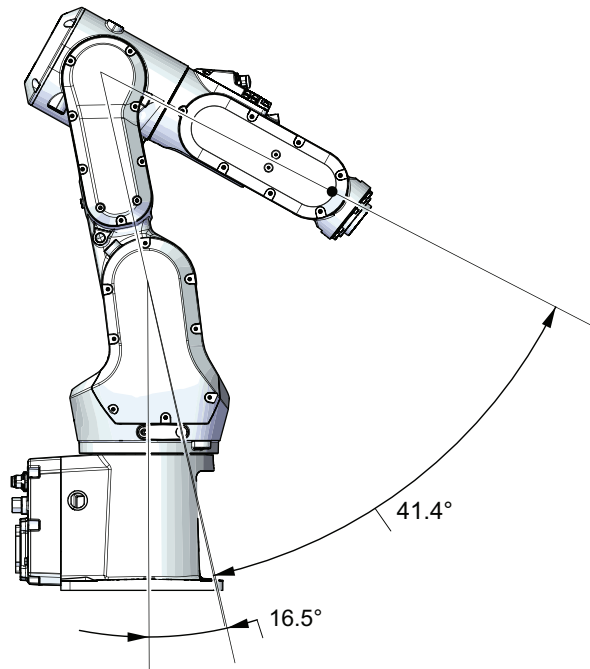

xx1900000106

Continues on next page

3 Installation and commissioning

3.2.2 Risk of tipping/stability

Continued

IRB 1100-4/0.58

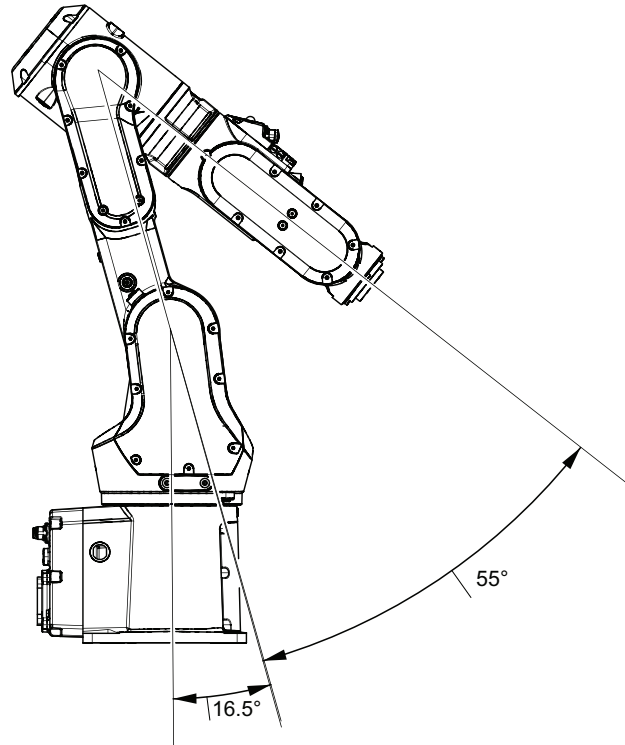

xx1800002440



Note

The robot might be positioned in a different position at delivery, due to actual configurations and options (for example DressPack).

Transportation bracket

At delivery, the robot is locked in the correct position with a transportation bracket for securing the position during shipping and transport. The bracket must be removed before conducting any service work.

How to use the transportation bracket is described further in [Transportation bracket \(3HAC068893-001\)](#) on page 56.



WARNING

The robot is likely to be mechanically unstable if not secured to the foundation.

3.2.3 Extra O-rings

Installation of extra O-rings

For robots with protection class IP67 (option 3350-670)

For robots with protection type Clean Room (option 3351-4)

An extra O-ring is delivered together with the robot and must be fitted to the robot during installation.

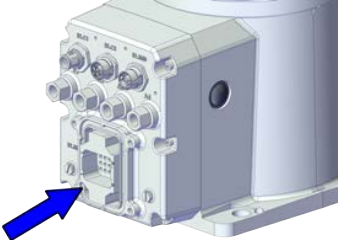
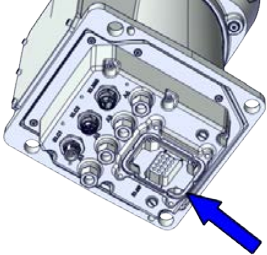
Equipment	Article number	Note
O-ring	3HAB3772-19	<p>Used with protection class IP67 and protection type Clean Room. Used to seal between the main power cable and connector. Robots with manipulator cables routed from the rear of the base:</p>  <p>xx1900002163</p> <p>Robots with manipulator cables routed from below (3309-1):</p>  <p>xx1900002164</p>

Further information

For installation information, see [On-site installation on page 58](#) and [Electrical connection on page 83](#).

3 Installation and commissioning

3.2.4 Transportation bracket (3HAC068893-001)

3.2.4 Transportation bracket (3HAC068893-001)

Location of the transportation bracket

At delivery, the robot is locked in the correct position with a transportation bracket for securing the position during shipping and transport. The bracket must be removed before conducting any service work and must be refitted before shipping and transportation.

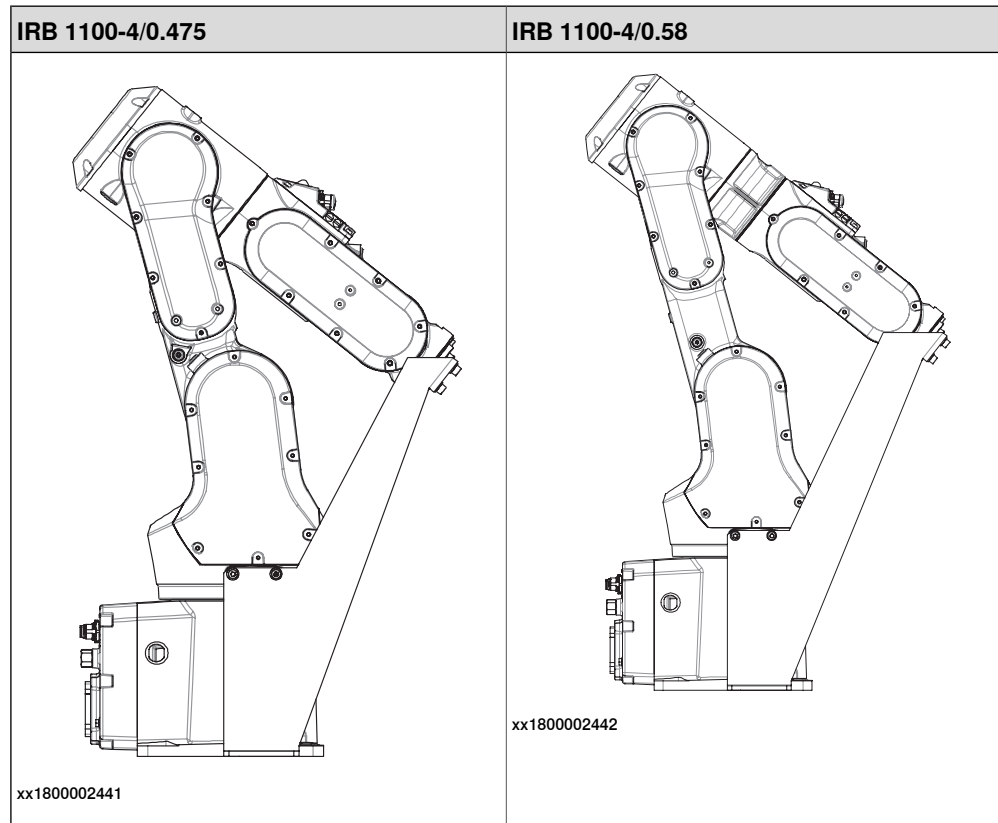

Removing the transportation bracket

	Action	Note
1	 <p data-bbox="571 1529 687 1559">CAUTION</p> <p data-bbox="480 1585 1018 1666">For Clean Room robots, it is important not to rub against the paint of the robot while performing any service work on the robot.</p>	

Continues on next page

3 Installation and commissioning

3.2.4 Transportation bracket (3HAC068893-001)

Continued

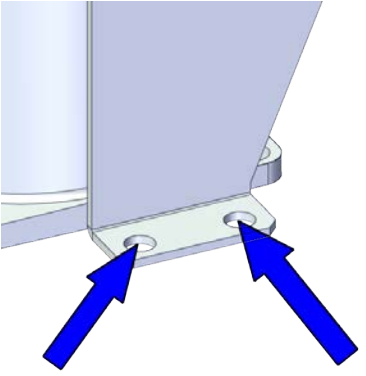
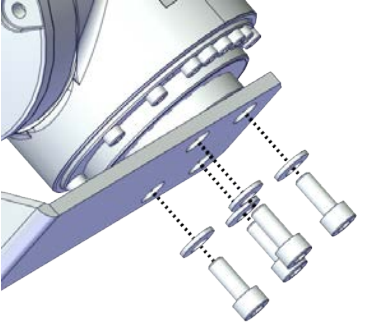
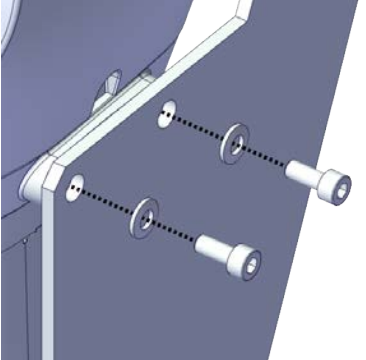
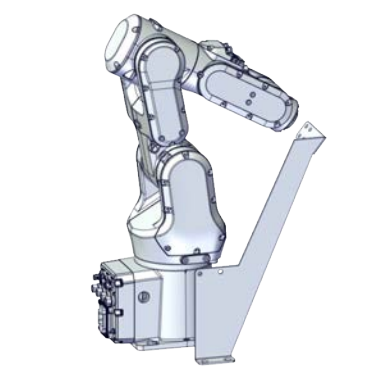
	Action	Note
2	If there are screws fixed to the pallet or foundation in the location shown in the figure, remove the screws and nuts.	 xx1900000105
3	Remove the screws and washers.	 xx1900000102  xx1900000103
4	Remove the bracket.	 xx1900000104

3 Installation and commissioning

3.3.1.1 Lifting the robot by one person

3.3 On-site installation

3.3.1 Lifting the robot

3.3.1.1 Lifting the robot by one person

General

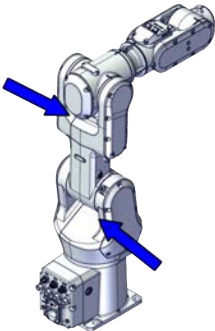
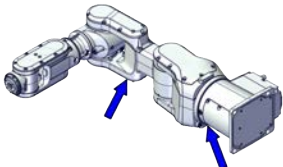
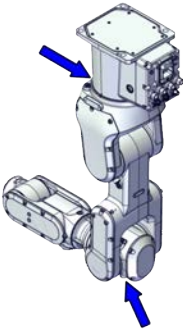

This section describes how to lift the robot and move it by one person.

Grasping location

Position	Grasping location	Note
Stand on foot	 xx1800002444	When the robot stands on its foot, grasp the robot with one hand holding the lower arm and the other hand holding the swing.
By side	 xx1800002445	When the robot lies by side, grasp the robot with one hand holding the lower arm and the other hand supporting at the base. It is recommended to hold the robot between your arm and body.
Inverted	 xx1800002446	When the robot is inverted, grasp the robot with one hand supporting at the housing and the other hand holding the base.

Continues on next page

Lifting and transporting the robot

	Action
1	 CAUTION The IRB 1100 weighs, 21.1 kg and can be lifted by one person.
2	Grasp the robot as instructed in Grasping location on page 58 .
3	Lift the robot.
4	Move the robot to desired position.  CAUTION Be careful so that the robot does not bump into something while lifting and transporting. It could damage the robot.
5	Secure the robot on a workbench according to section Orienting and securing the robot on page 61 .

3 Installation and commissioning

3.3.1.2 Lifting and rotating a suspended mounted robot

3.3.1.2 Lifting and rotating a suspended mounted robot

Introduction

How to lift and turn the robot to a **suspended** position: Contact ABB for more information.

How to lift and turn the robot into position for **wall** position: Contact ABB for more information.

3.3.2 Orienting and securing the robot

General

This section describes how to orient and secure the robot to the base plate or foundation in order to run the robot safely.

Attachment screws

The table below specifies the type of securing screws and washers to be used for securing the robot to the base plate/foundation.

Suitable screws	M12x25 (robot installation directly on foundation)
Quantity	4 pcs
Quality	8.8
Suitable washer	24 x 13 x 2.5, steel hardness class 200HV
Guide pins	2 pcs, D6x20, ISO 2338 - 6m6x20 - A1
Tightening torque	50 Nm±5 Nm
Length of thread engagement	Minimum 12.5 mm for ground with material yield strength 150 MPa
Level surface requirements	0.1/500 mm ⁱ

ⁱ See [Requirements, foundation on page 42](#).

Installation of extra O-rings

For robots with protection class IP67 (option 3350-670)

For robots with protection type Clean Room (option 3351-4)

Continues on next page

3 Installation and commissioning

3.3.2 Orienting and securing the robot

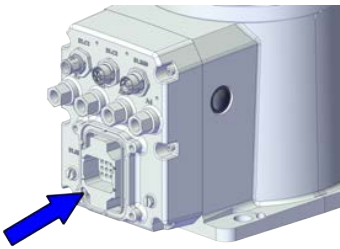
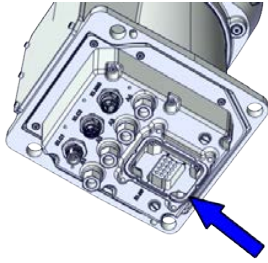

Continued

An extra O-ring is delivered together with the robot and must be fitted to the robot during installation.

Equipment	Article number	Note
O-ring	3HAB3772-19	<p>Used with protection class IP67 and protection type Clean Room. Used to seal between the main power cable and connector. Robots with manipulator cables routed from the rear of the base:</p>  <p>xx1900002163</p> <p>Robots with manipulator cables routed from below (3309-1):</p>  <p>xx1900002164</p>

Securing a floor mounted robot

Use this procedure to orient and secure the robot floor mounted.

	Action	Note
1	Make sure the installation site for the robot conforms to the specifications in section Technical data on page 40 .	
2	Prepare the installation site with attachment holes. The foundation surface must be clean and unpainted.	The hole configuration of the base is shown in the figure in Hole configuration, base on page 64 .
3	 CAUTION The weight of the IRB 1100 robot is 21.1 kg All lifting accessories used must be sized accordingly.	
4	 CAUTION When the robot is put down after being lifted or transported, there is a risk of it tipping, if not properly secured.	

Continues on next page

3 Installation and commissioning

3.3.2 Orienting and securing the robot

Continued

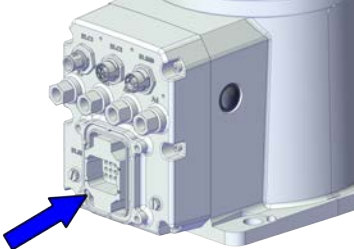
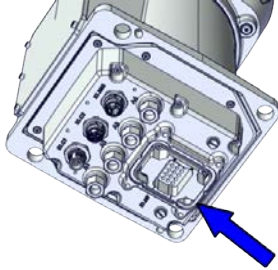
	Action	Note
5	Lift the robot.	See Lifting the robot on page 58 .
6	Fit two pins to the holes in the base.	2 pcs, D6x20, ISO 2338 - 6m6x20 - A1
7	Guide the robot gently, using the attachment screws while lowering it into its mounting position.	Make sure the robot base is correctly fitted onto the pins.
8	Fit the securing screws and washers in the attachment holes of the base.	Screws: M12x25 (robot installation directly on foundation), 4 pcs, quality 8.8 Washers: 24 x 13 x 2.5, steel hardness class 200HV
9	Tighten the bolts in a crosswise pattern to ensure that the base is not distorted.	Tightening torque: 50 Nm±5 Nm
10	<p>For robots with protection class IP67 (option 3350-670)</p> <p>For robots with protection type Clean Room (option 3351-4)</p> <p>Fit the O-ring 3HAB3772-19 to the main power connector on the robot base.</p>	<p>Robots with manipulator cables routed from the rear of the base:</p>  <p>xx1900002163</p> <p>Robots with manipulator cables routed from below (3309-1):</p>  <p>xx1900002164</p>

Continues on next page

3 Installation and commissioning

3.3.2 Orienting and securing the robot

Continued

Hole configuration, base

This illustration shows the hole configuration used when securing the robot.

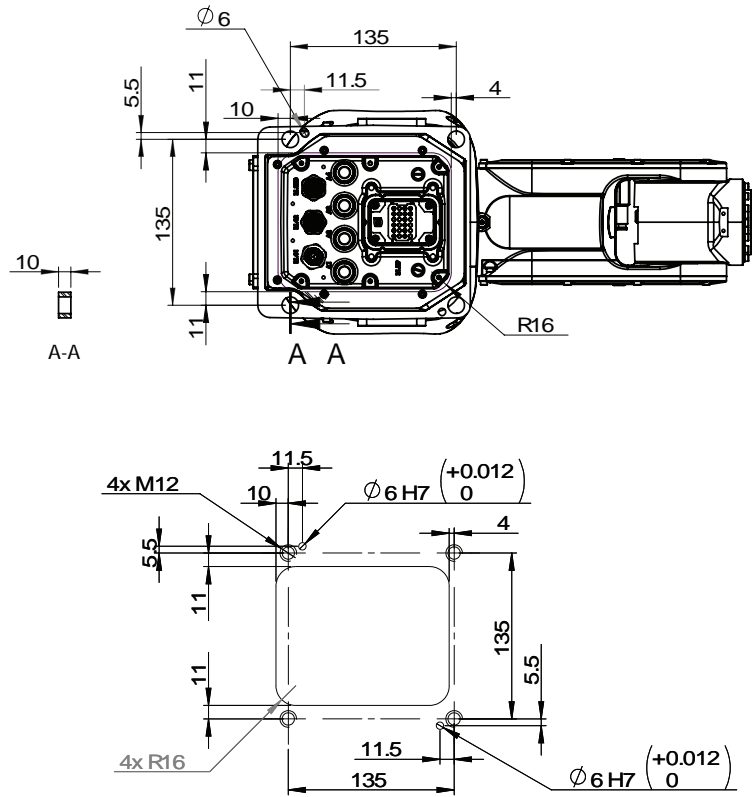

xx1800002448

3.3.3 Manually releasing the brakes

Introduction to manually releasing the brakes

This section describes how to release the holding brakes for the axes motors.

Location of the brake release unit

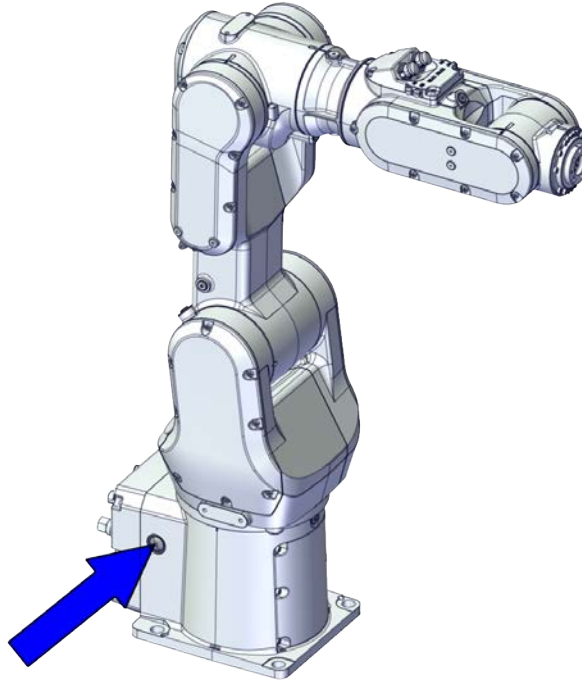

The brake release unit is located as shown in the figure.



xx1800002447

Releasing the brakes

This procedure describes how to release the holding brakes when the robot is equipped with a brake release unit.

	Action	Note
1	 Note If the robot is not connected to the controller, power must be supplied to the connector R1.MP according to the section Supplying power to connector R1.MP on page 66 .	
2	 DANGER When releasing the holding brakes, the robot axes may move very quickly and sometimes in unexpected ways. Make sure no personnel is near or beneath the robot.	

Continues on next page

3 Installation and commissioning

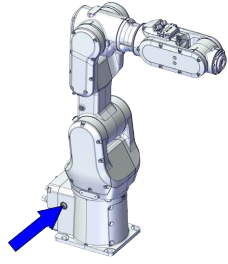

3.3.3 Manually releasing the brakes

Continued

	Action	Note
3	<p>Release the holding brake of all axes by pressing the brake release button.</p> <p>The brake will be enable as soon as the button is released.</p> <p> WARNING</p> <p>Pressing the brake release button will release the holding brakes on all axes simultaneously.</p>	 <p>xx1800002447</p>

Supplying power to connector R1.MP

If the robot is not connected to the controller, power must be supplied to connector R1.MP on the robot, in order to enable the brake release buttons.

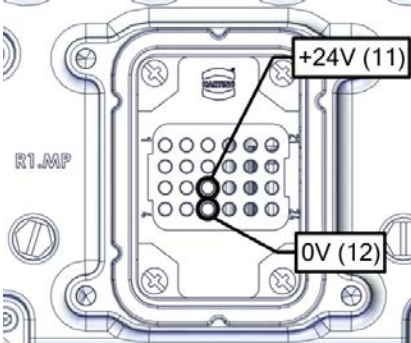
	Action	Note
1	<p> DANGER</p> <p>Incorrect connections, such as supplying power to the wrong pin, may cause all brakes to be released simultaneously and instantly!</p>	
2	<p>Supply</p> <ul style="list-style-type: none"> • 0V on pin 12. • 24V on pin 11. <p> Note</p> <p>Do not interchange the 24V and 0V pins. If they are mixed up, damage can be caused to internal electrical components.</p>	 <p>xx1800002443</p>
3	<p>Use the brake releasing button as described in Releasing the brakes on page 65.</p>	

3.3.4 Setting the system parameters for an inverted or a tilted robot

General

The robot is configured for mounting parallel to the floor, without tilting, on delivery. If the robot is mounted in any other angle than 0° , then the system parameters that describe the mounting angle (how the robot is oriented relative to the gravity) must be re-defined.



Note

With inverted installation, make sure that the gantry or corresponding structure is rigid enough to prevent unacceptable vibrations and deflections, so that optimum performance can be achieved.



Note

The mounting positions are described in [Mounting positions on page 40](#), and the requirements on the foundation are described in [Requirements, foundation on page 42](#).

System parameters



Note

The mounting angle must be configured correctly in the system parameters so that the robot system can control the movements in the best possible way. An incorrect definition of the mounting angle will result in:

- Overloading the mechanical structure.
- Lower path performance and path accuracy.
- Some functions will not work properly, for example *Load Identification* and *Collision detection*.

Gravity Beta

When the robot is mounted other than floor-standing (rotated around the y-axis), the robot base frame and the system parameter *Gravity Beta* must be redefined. If the robot is mounted upside down (inverted), then *Gravity Beta* should be π (+3.141593).

If the robot is mounted on a wall, then *Gravity Beta* should be $\pm\pi/2$ (± 1.570796).

The *Gravity Beta* is a positive rotation direction around the y-axis in the base coordinate system. The value is set in radians.

Gravity Alpha

If the robot is mounted on a wall (rotated around the x-axis), then the robot base frame and the system parameter *Gravity Alpha* must be redefined. The value of *Gravity Alpha* should then be $\pm\pi/2$ (± 1.570796).

Continues on next page

3 Installation and commissioning

3.3.4 Setting the system parameters for an inverted or a tilted robot

Continued

The *Gravity Alpha* is a positive rotation direction around the x-axis in the base coordinate system. The value is set in radians.



Note

The system parameter *Gravity Alpha* is not supported for all robot types. If the robot does not support *Gravity Alpha*, then use *Gravity Beta* along with the re-calibration of axis 1 to define the rotation of the robot around the x-axis.



Note

The parameter is supported for all robots on track when the system parameter *7 axes high performance motion* is set, see *Technical reference manual - System parameters*.

Gamma Rotation

Gamma Rotation defines the orientation of the robot foot on the travel carriage (track motion).

Mounting angles and values

The parameter *Gravity Beta* (or *Gravity Alpha*) specifies the mounting angle of the robot in radians. It is calculated in the following way.

$\text{Gravity Beta} = A^\circ \times 3.141593/180 = B \text{ radians}$, where **A** is the mounting angle in degrees and **B** is the mounting angle in radians.

Example of position	Mounting angle (A °)	Gravity Beta
Floor mounted	0°	0.000000 (Default)
Wall mounted	90°	1.570796
Inverted mounting	180°	3.141593

Continues on next page

3 Installation and commissioning

3.3.4 Setting the system parameters for an inverted or a tilted robot

Continued

Examples of mounting angles tilted around the Y axis (*Gravity Beta*)

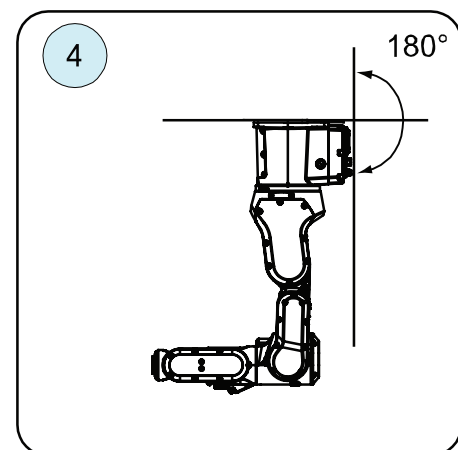
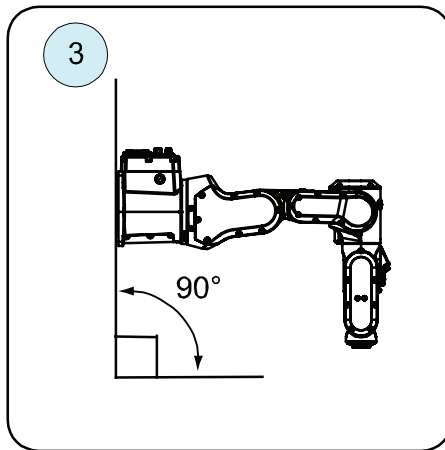
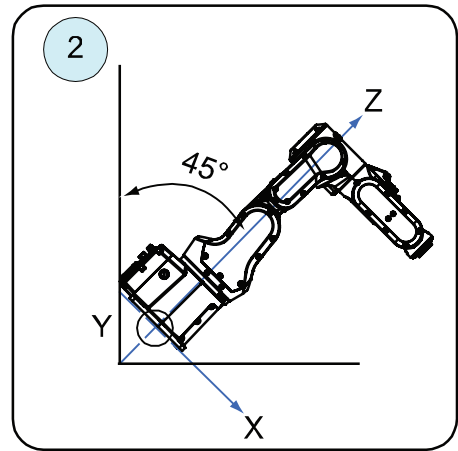
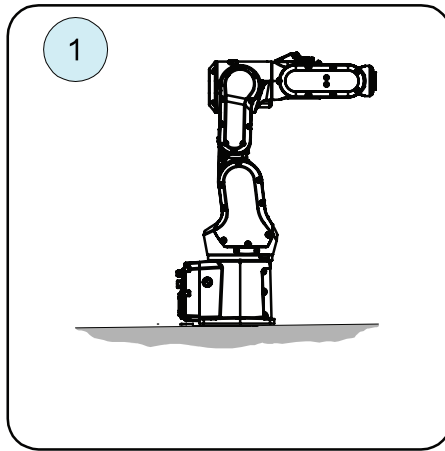

xx1800002454

Pos 1	Floor mounted
Pos 2	Mounting angle 45° (Tilted)
Pos 3	Mounting angle 90° (Wall)
Pos 4	Mounting angle 180° (Suspended)

Continues on next page

3 Installation and commissioning

3.3.4 Setting the system parameters for an inverted or a tilted robot

Continued

Examples of mounting angles tilted around the X axis (*Gravity Alpha*)

The following illustration shows the IRB 120, but the same principle applies for all robots.

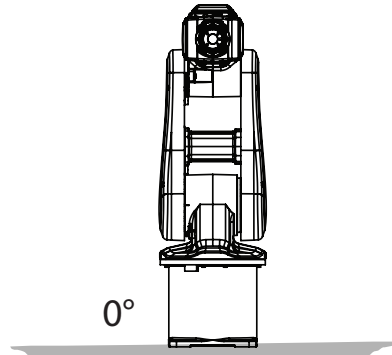

xx2100000297

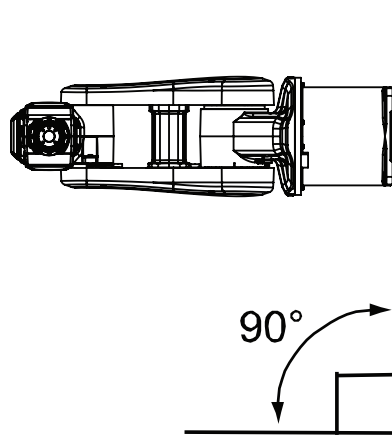

xx2100000299

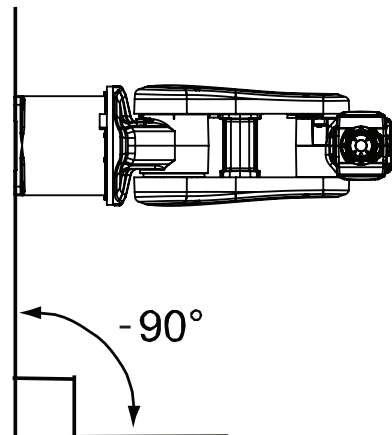

xx2100000300

Mounting angle	Gravity Alpha
0° (Floor mounted)	0
90° (Wall)	1.570796
-90° (Wall)	-1.570796



Note

For suspended robots (180°), it is recommended to use *Gravity Beta* instead of *Gravity Alpha*.

Limitations in working area

If mounting the robot on a wall, the working range of axis 1 is limited. These limitations are specified in the table [Working range on page 48](#).

Defining the system parameters in RobotWare

The value of the system parameters that define the mounting angle must be redefined when changing the mounting angle of the robot. The parameters belong to the type *Robot*, in the topic *Motion*.

Continues on next page

The system parameters are described in *Technical reference manual - System parameters*.

The system parameters are configured in RobotStudio or on the FlexPendant.

3 Installation and commissioning

3.3.5 Loads fitted to the robot, stopping time and braking distances

3.3.5 Loads fitted to the robot, stopping time and braking distances

Define loads carefully

Any loads mounted on the robot must be defined correctly and carefully (with regard to the position of center of gravity and mass moments of inertia) in order to avoid jolting movements and overloading motors, gears and structure.



CAUTION

Incorrectly defined loads may result in operational stops or major damage to the robot.

Load diagrams, permitted extra loads (equipment) and their positions are specified in the product specification. The loads must be defined in the software.

Stopping time and braking distances

The performance of the motor brake depends on if there are any loads attached to the robot.

See the product specification for the robot, listed in [References on page 10](#).

3.3.6 Fitting equipment on the robot (robot dimensions)

Robot dimensions

Dimensions IRB 1100-4/0.475

The figure shows the dimension of the IRB 1100-4/0.475.

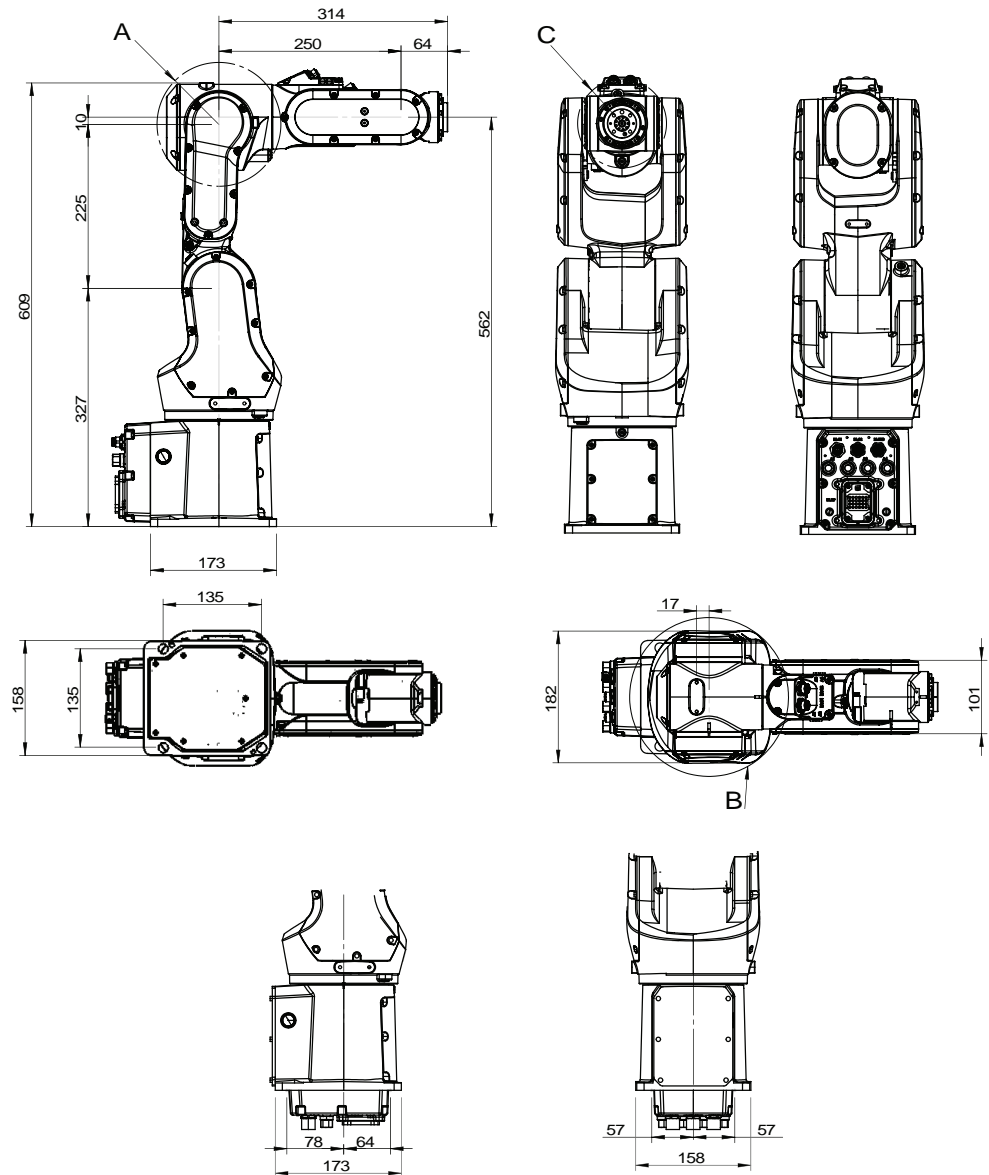

xx1800002606

Pos	Description
A	Turning radius: R85
B	Turning radius: R109
C	Turning radius: R61

Continues on next page

3 Installation and commissioning

3.3.6 Fitting equipment on the robot (robot dimensions)

Continued

Dimensions IRB 1100-4/0.58

The figure shows the dimension of the IRB 1100-4/0.58.

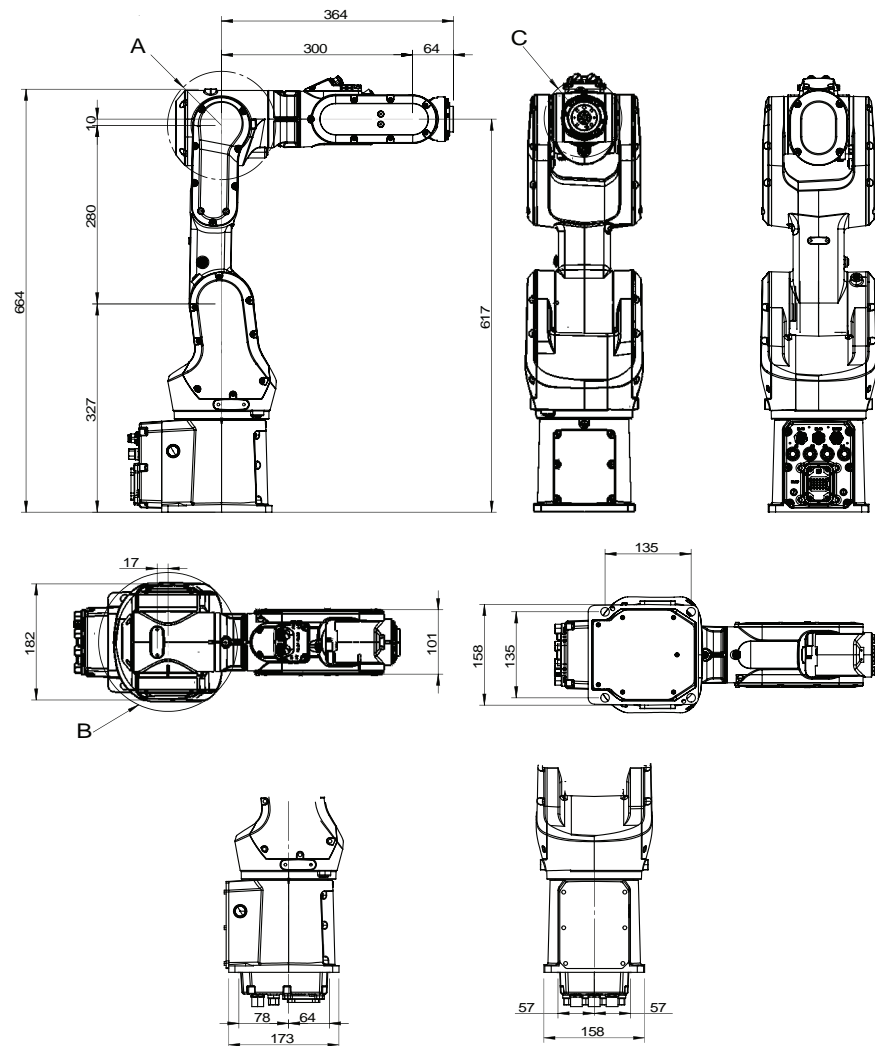

xx1800002607

Pos	Description
A	Turning radius: R85
B	Turning radius: R109
C	Turning radius: R61

Attachment holes and dimensions

Extra loads can be mounted on robot. Definitions of dimensions and masses are shown in the following figures. The robot is supplied with holes for fitting extra equipment.

Continues on next page

3 Installation and commissioning

3.3.6 Fitting equipment on the robot (robot dimensions)

Continued

Maximum allowed arm load depends on center of gravity of arm load and robot payload.

Holes for fitting extra equipment

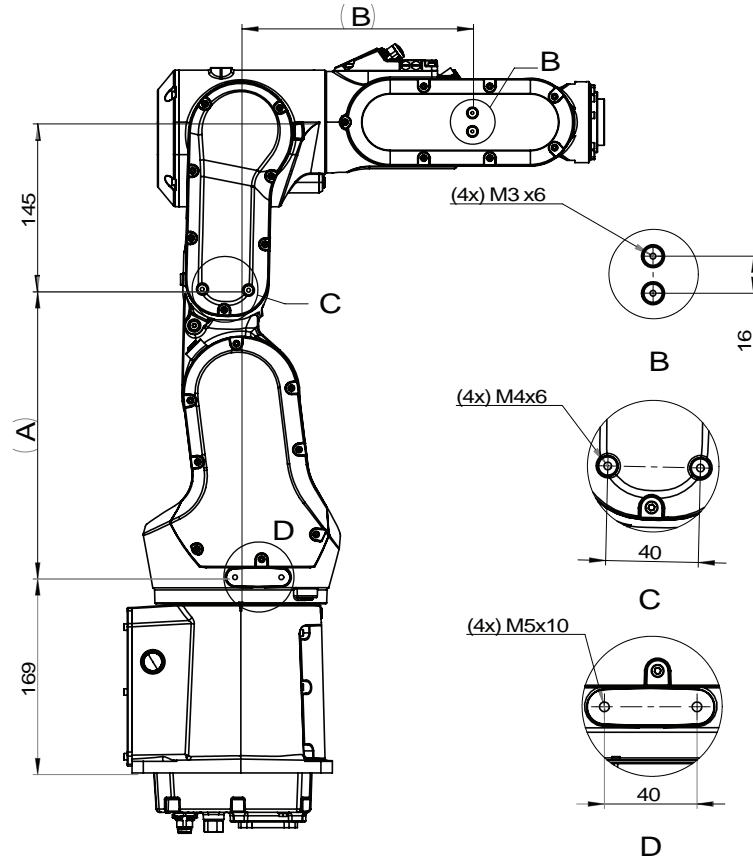

xx1800002449

Pos	4/0.475	4/0.58
A	248	303
B	200	250

Continues on next page

3 Installation and commissioning

3.3.6 Fitting equipment on the robot (robot dimensions)

Continued

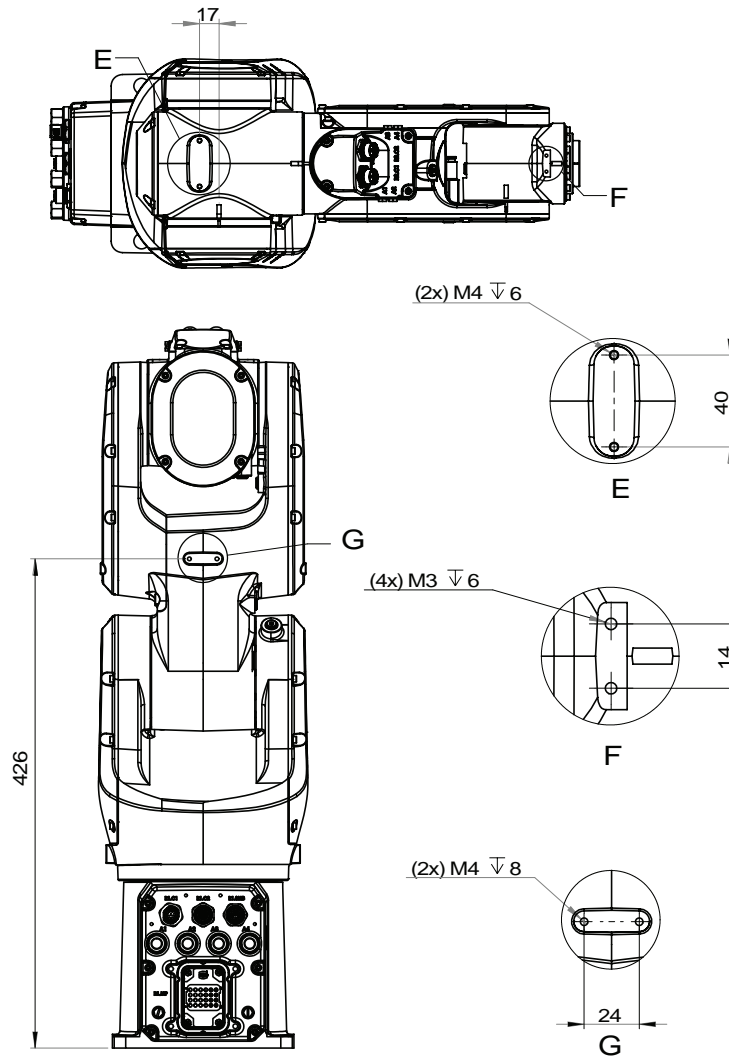

xx1800002450

Continues on next page

Tool flange standard

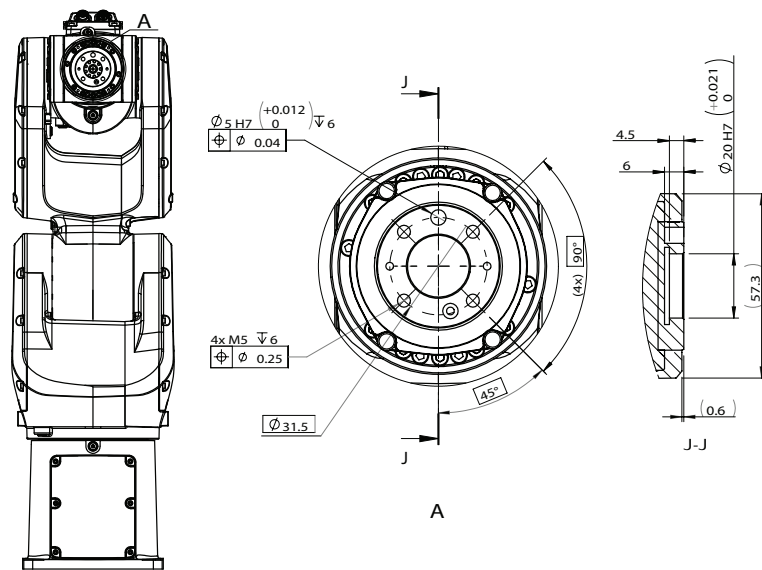

xx1800002451



CAUTION

To calibrate the axis 6, the notch on the wrist must be aligned with the marked pin hole on the tool flange. Before installing a tool on the tool flange, make sure a visible mark has been made to the tool at the corresponding position.

For details about the synchronization mark, see [Synchronization marks and synchronization position for axes on page 689](#).

Fastener quality

When fitting tools on the tool flange, only use screws with quality 12.9. For other equipment use suitable screws and tightening torque for your application.

3 Installation and commissioning

3.3.7 Installation of signal lamp (option)

3.3.7 Installation of signal lamp (option)



Description

A signal lamp with a yellow fixed light can be mounted in the cell or any other visible location, and driven by I/O signal or MON_LAMP signal from the controller.



Function

The lamp is active in MOTORS ON mode.

Installation of signal lamp from I/O signal

	Action
1	 DANGER Make sure that all supplies for electrical power, hydraulic pressure, and air pressure are turned off.
2	For robots with OmniCore C line Connect the lamp cable connector to the local I/O connector on the controller.  Note The local I/O connectors provides 16 digital output signals for use.
3	For robots with OmniCore E line Connect the lamp cable connector to the I/O connector on the controller.  Note The I/O connectors provides 8 digital output signals for use.
4	Configure the lamp by adding a <i>System Output</i> type signal with status set to <i>Motors On State</i> .
5	The lamp is now ready for use and is lit in MOTORS ON mode.

Installation of signal lamp from MON_LAMP signal

	Action
1	 DANGER Make sure that all supplies for electrical power, hydraulic pressure, and air pressure are turned off.
2	For robots with OmniCore C line Connect the lamp cable connector to the X15 connector on the controller.  Note The X15 connector provides MON_LAMP output signals for use. For more details, see chapter <i>Descriptions for connectors</i> in OmniCore product manuals.

Continues on next page

	Action
3	<p>For robots with OmniCore E line Connect the lamp cable connector to the MON connector on the controller.</p> <p> Note</p> <p>The MON connector provides MON_LAMP output signals for use. For more details, see chapter <i>Descriptions for connectors</i> in OmniCore product manuals.</p>
4	The lamp is now ready for use and is lit in MOTORS ON mode.

Further information

Further information about the MOTORS ON/MOTORS OFF mode may be found in the product manual for the controller.

Further information about how to set up I/O system may be found in *Technical reference manual - System parameters*.

3 Installation and commissioning

3.4.1 Adjusting the working range

3.4 Restricting the working range

3.4.1 Adjusting the working range

Reasons for adjusting the manipulator working range

The working range of each manipulator axis is configured in the software. If there is a risk that the manipulator may collide with other objects at installation site, its working space should be limited. The manipulator must always be able to move freely within its entire working space.

Working range configurations

The parameter values for the axes working range can be altered within the allowed working range and according to available options for the robot, either to limit or to extend a default working range. Allowed working ranges and available options for each manipulator axis are specified in [Working range on page 48](#).

Mechanical stops on the manipulator

Mechanical stops are and can be installed on the manipulator as limiting devices to ensure that the manipulator axis does not exceed the working range values set in the software parameters.



Note

The mechanical stops are only installed as safety precaution to physically stop the robot from exceeding the working range set. A collision with a mechanical stop always requires actions for repair and troubleshooting.

Axis	Fixed mechanical stop ⁱ	Movable mechanical stop ⁱⁱ
Axis 1	yes	no
Axis 2	yes	no
Axis 3	yes	no
Axis 4	no	no
Axis 5	yes	no
Axis 6	no	no

ⁱ Part of the casting or fixed on the casting and can not /should not be removed.

ⁱⁱ Can be installed in one or more than one position, to ensure a reduced working range, or be removed to allow extended working range.

3.4.2 Mechanically restricting the working range

Location of the mechanical stops

Only axis 1 has a replaceable mechanical stop.

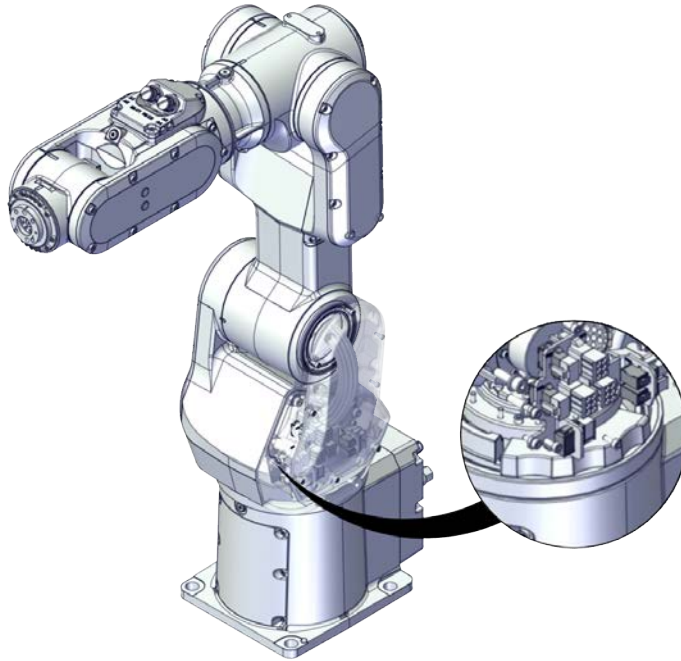

xx1800002452

Required spare parts



Note

The spare part numbers that are listed in the table can be out of date. See the latest spare parts of the IRB 1100 via myABB Business Portal, www.abb.com/myABB.

Spare part	Article number	Note
Mechanical stop, axis 1	3HAC061947-001	Replace if damaged.

Replacement of the axis-1 mechanical stop

The axis-1 mechanical stop is accessible after removing the base, see [Replacing the base on page 226](#).

3 Installation and commissioning

3.5.1 Additional installation procedure, Clean Room

3.5 Making robot ready for operation

3.5.1 Additional installation procedure, Clean Room

General

Robots with protection type Clean Room are specially designed to work in a clean room environment.

Clean Room robots are designed to prevent from particle emission from the robot. For example, the maintenance work possible to perform without cracking the paint. The robot is painted with four layers of polyurethane paint. The last layer being a varnish over labels to simplify cleaning. The paint has been tested regarding outgassing of Volatile Organic Compounds (VOC) and been classified in accordance with ISO 14644-8.

Any Clean Room parts that are replaced must be replaced with parts designed for use in Clean Room environments.

Clean Room class 4

According to **IPA test result**, the robot IRB 1100 is suitable for use in Clean Room environment.

Classification of airborne molecular contamination

Parameter				Outgassing amount		
Area (m ²)	Test duration (s)	Temp (°C)	Performed test	Total detected (ng)	Norm based on 1m ² and 1s(g)	Classification in accordance to ISO 14644-8
4.5E-03	3600	23	TVOC	2848	1.7E-07	-6.8
4.5E-03	60	90	TVOC	46524	1.7E-04	-3.8

Preparations before commissioning a Clean Room robot

During transport and handling of a Clean Room robot, it is likely that the robot has been contaminated with particles of different kinds. Therefore the robot must be carefully cleaned before installation.

Do not apply force on the plastic covers when lifting the robot! This may result in damage or cracks in the paint around the plastic cover.

3.6 Electrical connection

3.6.1 Robot cabling and connection points

Introduction

Connect the robot and controller to each other after securing them to the foundation. The lists below specify which cables to use for each respective application.



DANGER

Turn off the main power before connecting any cables.



CAUTION

Verify that the serial number is according to the number(s) in the *Declaration of Incorporation (DoI)*.

Main cable categories

The following table specifies cabling categories between the robot and the controller. Some of the cabling belong to optional applications.

Cable category	Description
Robot cables	Handles power supply to and control of the robot's motors as well as feedback from the serial measurement board. Specified in the table Robot cables on page 83 .
Customer cables	Handles communication with equipment fitted on the robot by the customer, low voltage signals and high voltage power supply + protective ground. The customer cables also handle databus communication. The customer cables also include the air hose. See the product manual for the controller, see document number in References on page 10 .
Air hoses	The hose for compressed air is integrated with the manipulator cable harness.

Robot cables

These cables are included in the standard delivery. They are completely pre-manufactured and ready to plug in.

Cable sub-category	Description	Connection point, cabinet	Connection point, robot
Robot cables, power	Transfers drive power from the drive units in the control cabinet to the robot motors.	X1	R1.MP
Robot cable, signals	Transfers resolver data from and power supply to the serial measurement board.	X2	R1.SMB

Continues on next page

3 Installation and commissioning

3.6.1 Robot cabling and connection points

Continued

Robot cable, power

Power cable length	Article number
Power cable, straight connector, 3 m	3HAC077245-001
Power cable, straight connector, 7 m	3HAC077245-002
Power cable, straight connector, 15 m	3HAC077245-003
Power cable, angled connector, 3 m	3HAC077247-001
Power cable, angled connector, 7 m	3HAC077247-002
Power cable, angled connector, 15 m	3HAC077247-003

Robot cable, signals

Signal cable length	Article number
Signal cable, shielded: 3 m	3HAC084767-001
Signal cable, shielded: 7 m	3HAC084767-002
Signal cable, shielded: 15 m	3HAC084767-003

Bending radius for static floor cables

The minimum bending radius is 10 times the cable diameter for static floor cables.

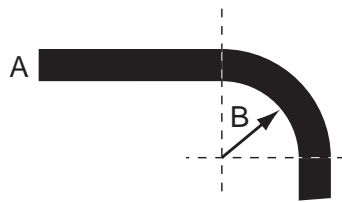

xx1600002016

A	Diameter
B	Diameter x10

Continues on next page

3 Installation and commissioning

3.6.1 Robot cabling and connection points

Continued

Grounding and bonding point on manipulator

There is a grounding/bonding point on the manipulator base. The grounding/bonding point is used for potential equalizing between control cabinet, manipulator and any peripheral devices.

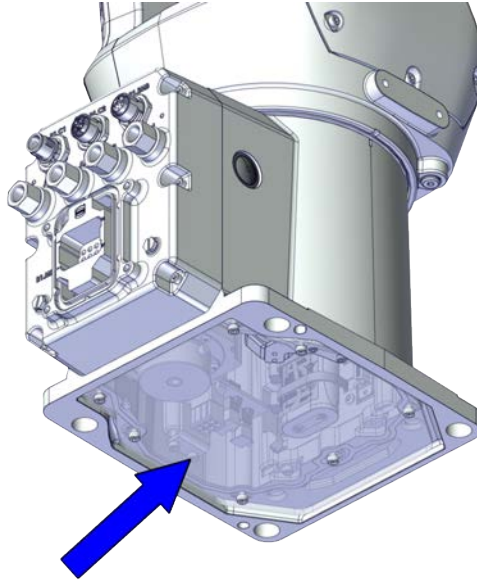

xx1800002453

Installation of extra O-rings

For robots with protection class IP67 (option 3350-670)

For robots with protection type Clean Room (option 3351-4)

Continues on next page

3 Installation and commissioning

3.6.1 Robot cabling and connection points

Continued

An extra O-ring is delivered together with the robot and must be fitted to the robot during installation.

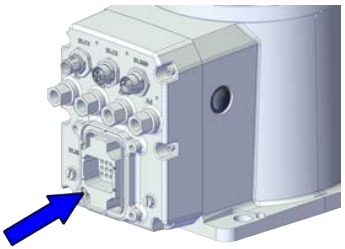
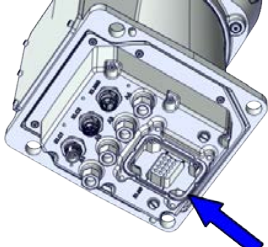
Equipment	Article number	Note
O-ring	3HAB3772-19	<p>Used with protection class IP67 and protection type Clean Room. Used to seal between the main power cable and connector. Robots with manipulator cables routed from the rear of the base:</p>  <p>xx1900002163</p> <p>Robots with manipulator cables routed from below (3309-1):</p>  <p>xx1900002164</p>

Customer cables - CP/CS cable

CP/CS cable length	Article number ⁱ
3 m	3HAC067449-001
7 m	3HAC067449-002
15 m	3HAC067449-003

ⁱ It is recommended to always use the CP/CS cable provided by ABB. If users still require to do wiring by their own, make sure to use R1.C1 connector in M12 A-code 12p female type. It is the responsibility of the users to guarantee the safety of the system when self-prepared cables and connectors are used.

Customer cables - Ethernet floor cable

Ethernet floor cable length	Article number ⁱ
7 m	3HAC067447-002
15 m	3HAC067447-003

ⁱ It is recommended to always use the Ethernet floor cable provided by ABB. If users still require to do wiring by their own, make sure to use R1.C2 connector in M12 X-code male type. It is the responsibility of the users to guarantee the safety of the system when self-prepared cables and connectors are used.

3.6.2 Customer connections

Introduction to customer connections

The cables for customer connection are integrated in the robot and the connectors are placed on the wrist and one at the base. There is one connector R2.C1 at the wrist. Corresponding connector R1.C1 is located at the base.

There is also connections for Ethernet, one connector R2.C2 at the wrist and the corresponding connector R1.C2 located at the base.

Hose for compressed air is also integrated into the manipulator. There are 4 inlets at the base (R1/8") and 4 outlets (M5) on the wrist.

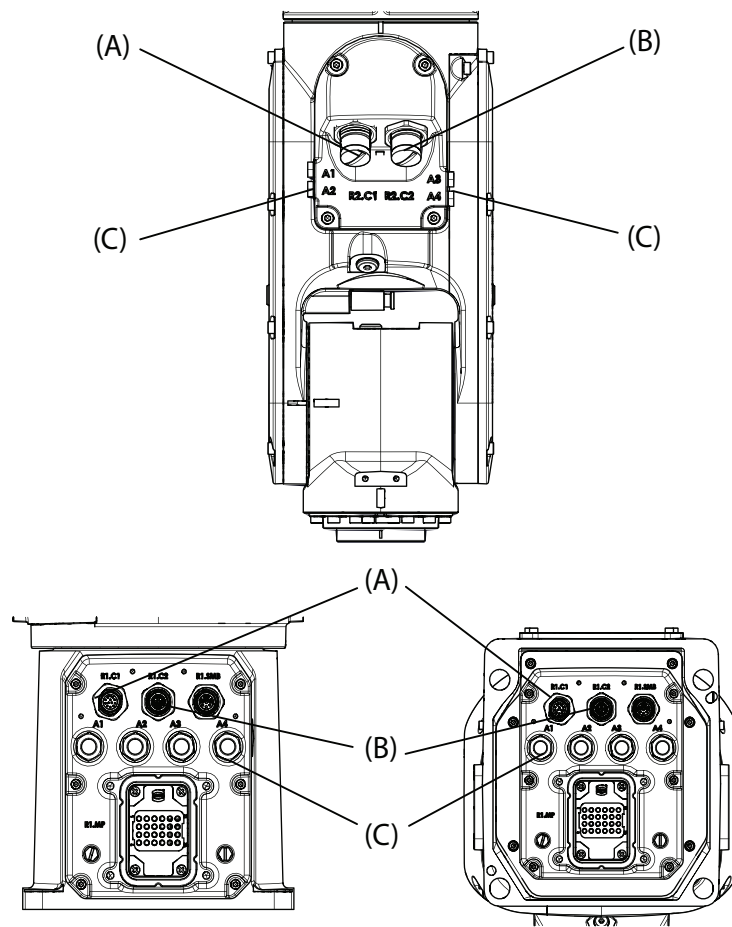

xx190000131

Position	Connection	Description	Number	Value
A	(R1)R2.C1	Customer power/signal	8 wires ⁱ	30 V, 1.5 A
B	(R1)R2.C2	Customer power/signal or Ethernet	8 wires	30 V, 1 A or 1 Gbits/s
C	Air	Max. 6 bar	4	Outer diameter of air hose: 4 mm

ⁱ The connector has 12 pins. Only pins 1 to 8 are available for use.

Continues on next page

3 Installation and commissioning

3.6.2 Customer connections

Continued

Connector kits (optional)

Connector kits, base

R1.C1 and R1.C2 connectors on the base are parts of the CP/CS cable and Ethernet floor cable, respectively. For details about the robot cabling, see [Robot cabling and connection points on page 83](#).

Connector kits, wrist

The table describes the CP/CS and Ethernet (if any) connector kits for wrist.

Position	Description		Art. no.
Connector kits	CP/CS	M12 CPCS Male straight connector kits	3HAC066098-001
		M12 CPCS Male angled connector kits	3HAC066099-001
	Ethernet	M12 Ethernet Cat5e Male straight connector kits	3HAC067413-001
		M12 Ethernet Cat5e Male angled connector kits	3HAC067414-001

Protection covers

Protection covers for water and dust proofing

Protection covers are delivered together with the robot and must be well fitted to the connectors in any application requiring water and dust proofing.

Always remember to refit the protection covers after removing them.

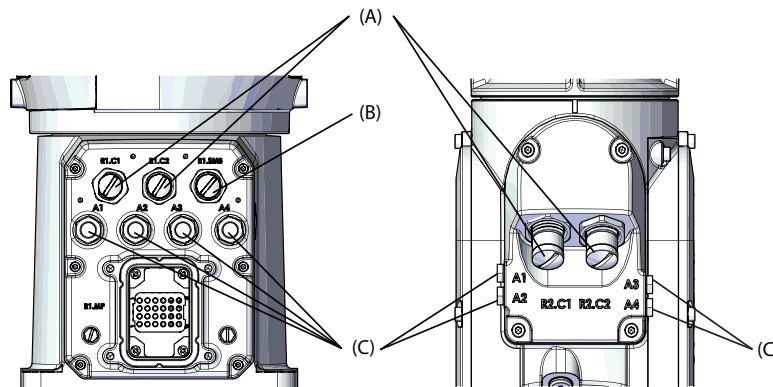

xx190000132

A	CP/CS or Ethernet connector protection covers
B	SMB connector protection cover
C	Air hose connector protection covers

3.7 Start of robot in cold environments

Introduction

This section describes how to start the robot in a cold environment if it is not starting the normal way.

Problems with starting the robot

Event message from Motion Supervision

Use this procedure if an event message indicates a problem with Motion supervision at start-up. More information about Motion Supervision is found in *Technical reference manual - System parameters*.

	Action	Note
1	Turn off Motion Supervision.	
2	Start the robot.	If the controller reports other event messages, see Robot stopping with other event message on page 89 .
3	When the robot has reached normal working temperature, the Motion Supervision can be turned on again.	

Robot stopping with other event message

Use this procedure if the robot is not starting.

	Action	Note
1	Start the robot with its normal program but with reduced speed.  Note It is recommended to reduce the speed to a value smaller than 40% of the normal programmed speed.	The speed can be regulated with the RAPID instruction <code>VelSet</code> or the speed regulator on the FlexPendent.
2	After 10 minutes or more, run the robot with the normal speed again.	The warm up duration varies according to the working cycle. If the working cycle is not tough enough, a longer warm up duration is required.

Adjusting the speed and acceleration during warm-up

Depending on how cold the environment is and what program is being used, the speed might need to be ramped up until reached maximum. The table shows examples of how to adjust the speed:

Work cycles	AccSet	Speed/velocity
3 Work cycles	20, 20	v100 (100 mm/s)
5 Work cycles	40, 40	v400 (400 mm/s)
5 Work cycles	60, 60	v600 (600 mm/s)
5 Work cycles	100, 100	v1000 (1000 mm/s)
More than 5 Work cycles	100, 100	Max.

Continues on next page

3 Installation and commissioning

3.7 Start of robot in cold environments

Continued

If the program consists of large wrist movements, it is possible that the reorientation velocity, which is always high in predefined velocities, needs to be included in the ramping up.

3.8 Test run after installation, maintenance, or repair

Safe handling

Use the following procedure after installation, maintenance, or repair, before initiating motion.



DANGER

Initiating motion without fulfilling the following aspects, may increase the risk for injury or cause damage to the robot.

	Action
1	Remove all tools and foreign objects from the robot and its working area.
2	Verify that the robot is properly secured to its position by all screws, before it is powered up.
3	Verify that any safety equipment installed to secure the position or restrict the robot motion during service activity is removed.
4	Verify that the fixture and work piece are well secured, if applicable.
5	Verify that all safety equipment is installed, as designed for the application.
6	Verify that no personnel are inside the safeguarded space.
7	If maintenance or repair has been done, verify the function of the part that was maintained.
8	Verify the application in the operating mode manual reduced speed.

Collision risks



CAUTION

When programming the movements of the robot, always identify potential collision risks before initiating motion.

This page is intentionally left blank

4 Maintenance

4.1 Introduction

Structure of this chapter

This chapter describes all the maintenance activities recommended for the IRB 1100.

It is based on the maintenance schedule found at the beginning of the chapter. The schedule contains information about required maintenance activities including intervals, and refers to procedures for the activities.

Each procedure contains all the information required to perform the activity, including required tools and materials.

The procedures are gathered in different sections and divided according to the maintenance activity.

Safety information

Observe all safety information before conducting any service work.

There are general safety aspects that must be read through, as well as more specific safety information that describes the danger and safety risks when performing the procedures. Read the chapter [Safety on page 17](#) before performing any service work.

The maintenance must be done by qualified personnel in accordance with the safety requirements set forth in the applicable national and regional standards and regulations.



Note

If the IRB 1100 is connected to power, always make sure that the IRB 1100 is connected to protective earth and a residual current device (RCD) before starting any maintenance work.

For more information see:

- *Product manual - OmniCore C30*
- *Product manual - OmniCore C90XT*
- *Product manual - OmniCore E10*
- [Robot cabling and connection points on page 83.](#)

4 Maintenance

4.2.1 Specification of maintenance intervals

4.2 Maintenance schedule and expected component life

4.2.1 Specification of maintenance intervals

Introduction

The intervals are specified in different ways depending on the type of maintenance activity to be carried out and the working conditions of the IRB 1100:

- Calendar time: specified in months regardless of whether the system is running or not.
- Operating time: specified in operating hours. More frequent running means more frequent maintenance activities.
- SIS: specified by the robot's SIS (Service Information System). A typical value is given for a typical work cycle, but the value will differ depending on how hard each part is run.

The SIS used in OmniCore is further described in the *Operating manual - OmniCore*.

Robots with the functionality *Service Information System* activated can show active counters in the device browser in RobotStudio, or on the FlexPendant.

4.2.2 Maintenance schedule

Scheduled and non-predictable maintenance

The robot must be maintained regularly to ensure proper function. The maintenance activities and intervals are specified in the table below.

Non-predictable situations also give rise to inspections of the robot. Any damages must be attended to immediately!

Life of each component

The inspection intervals *do not* specify the life of each component. Values for these are specified in the section [Expected component life on page 97](#)

Maintenance schedule

Maintenance activities	Regularly ⁱ	Every 12 months	Every 36 months	Every 30,000 hours ⁱⁱ	Reference
Cleaning the robot	x				Cleaning the IRB 1100 on page 98
Inspecting the robot	x				Check for abnormal wear or contamination. For robots with protection type Clean Room: Inspect daily
Inspecting the information labels		x			Inspecting the information labels on page 101
Inspecting the timing belt ⁱⁱⁱ			x		Inspecting timing belts on page 104
Inspecting the robot harness		x ^{iv}			Inspecting the robot cabling on page 103
Lubricating the robot harness		x ^v			Lubricating the cable package on page 109
Replacing the SMB battery pack			x ^{vi}		Replacing the battery pack on page 111
Running the <i>Brake Check</i> routine ^{vii}	x ^{viii}				Recommended to robots without the SafeMove option. See <i>Operating manual - OmniCore</i> .
Running the <i>Cyclic Brake Check</i> routine ^{vii}	x ^{viii}				Recommended to robots with the SafeMove option. See <i>Application manual - Functional safety and SafeMove</i> .
Overhaul of complete robot				x	

ⁱ "Regularly" implies that the activity is to be performed regularly, but the actual interval may not be specified by the robot manufacturer. The interval depends on the operation cycle of the robot, its working environment and movement pattern. Generally, the more contaminated environment, the shorter intervals. The more demanding movement pattern (sharper bending cable harness), the shorter intervals.

ⁱⁱ Operating hours counted by the DTC = Duty time counter.

Continues on next page

4 Maintenance

4.2.2 Maintenance schedule

Continued

- iii Axis-1 and axis-4 timing belts can be accessed and inspected only after the axis-1 and axis-4 motors are removed. It is recommended to inspect the timing belts when replacing the motors.
- iv Replace when damage or cracks is detected or life limit is approaching.
- v Replace when damage or cracks is detected or life limit is approaching.
- vi The battery is to be replaced at given maintenance interval or at battery low alert.
- vii Not needed separately if already included in the application.
- viii Recommended test interval is within the range 8-48 hours.

4.2.3 Expected component life

Expected life depends on usage

The expected life of a specific component of the robot can vary greatly depending on how hard it is run.

Expected component life

Component	Expected life	Note
Cable harness, normal usage ⁱ	30000 hours ⁱⁱ	
Cable harness, extreme usage ⁱⁱⁱ	30000 hours ⁱⁱ	
Gearboxes	30000 hours	

ⁱ Examples of "normal usage" in regard to movement: most material handling applications and limited use of bending backwards mode of axis 3.

ⁱⁱ Severe chemical or thermal environments, or similar environments, can result in shortened life expectancy.

ⁱⁱⁱ Examples of "extreme usage" in regard to movement: press tending, very severe palletizing applications, major use of axis 1 movement and major use of bending backwards of axis 3.

4 Maintenance

4.3.1 Cleaning the IRB 1100

4.3 Cleaning activities

4.3.1 Cleaning the IRB 1100

General

To secure high uptime it is important that the IRB 1100 is cleaned regularly. The frequency of cleaning depends on the environment in which the manipulator works. Different cleaning methods are allowed depending on the type of protection of the IRB 1100.



Note

Always verify the protection type of the robot before cleaning.



WARNING

Turn off all electrical power supplies to the robot before starting the cleaning.

Special cleaning considerations

This section specifies some special considerations when cleaning the robot.

- Always use cleaning equipment as specified. Any other cleaning equipment may shorten the life of the robot.
- Always check that all protective covers are fitted to the robot before cleaning.
- Do not point the water jet at connectors, joints, sealings or gaskets.
- Do not use compressed air to clean the robot.
- Do not use solvents that are not approved by ABB to clean the robot.
- Do not remove any covers or other protective devices before cleaning the robot.

Cleaning methods

The following table defines what cleaning methods are allowed for ABB manipulators depending on the protection type.

Protection type	Cleaning method			
	Vacuum cleaner	Wipe with cloth	Rinse with water	High pressure water, steam or spray
Standard IP40	Yes	Yes. With light cleaning detergent.	No	No
IP67 (option)	Yes	Yes. With light cleaning detergent.	Yes. It is highly recommended that the water contains a rust-prevention solution and that the manipulator is dried afterwards.	No

Continues on next page

Protection type	Cleaning method			
	Vacuum cleaner	Wipe with cloth	Rinse with water	High pressure water, steam or spray
Clean room	Yes	Yes. With light cleaning detergent. See Additional cleaning instructions for Clean Room robots on page 99 .	No	No

Wiping with cloth

Additional cleaning instructions for Clean Room robots

ABB robots with protection types *Clean Room* are designed to be cleaned at a low cleaning frequency, before entering the cleanroom environment, after robot commissioning or during cleanroom maintenance.

Wipe-down cleaning method is recommended. Robot surfaces shall be wiped with clean and low particle emission cleanroom cloth which is soaked in 70% ethanol

Use the following procedure to clean Clean Room robots:

- 1 Before cleaning, use the lint free cloth to remove dirt, debris or any other contaminant from the to-be cleaned surfaces.
 - Make sure no visible residues left.
 - Never apply hard forces on or rub against the robot surfaces to remove dirt or debris; otherwise, protective paint layers may be damaged.
- 2 Wet a clean cloth with the cleaning detergent and then wipe the robot painting surfaces.
 - Make sure no cleaning agents are sprayed onto robot surfaces or into the robot structure.
 - Wipe from the surface center to edge and always in the same direction.
- 3 Wait a few minutes for detergent volatilization.
 - Make sure no residue of cleaning agents left on the robot surfaces after wipe down cleaning.

Cleaning with water

Instructions for rinsing with water

IRB 1100 with protection class IP67 (option) can be cleaned by rinsing with water (water cleaner).¹

The following list defines the prerequisites:

- Maximum water pressure at the nozzle: 700 kN/m² (7 bar)¹
- Fan jet nozzle should be used, min. 45° spread
- Minimum distance from nozzle to encapsulation: 0.4 meters

¹ See [Cleaning methods on page 98](#) for exceptions.

Continues on next page

4 Maintenance

4.3.1 Cleaning the IRB 1100

Continued

- Maximum flow: 20 liters/min¹
- 1 Typical tap water pressure and flow

Cables

Movable cables need to be able to move freely:

- Remove waste material, such as sand, dust and chips, if it prevents cable movement.
- Clean the cables if they have a crusty surface, for example from dry release agents.

4.4 Inspection activities

4.4.1 Inspecting the information labels

Location of labels

These figures show the location of the information labels to be inspected. The symbols are described in section [Safety symbols on manipulator labels on page 21](#).

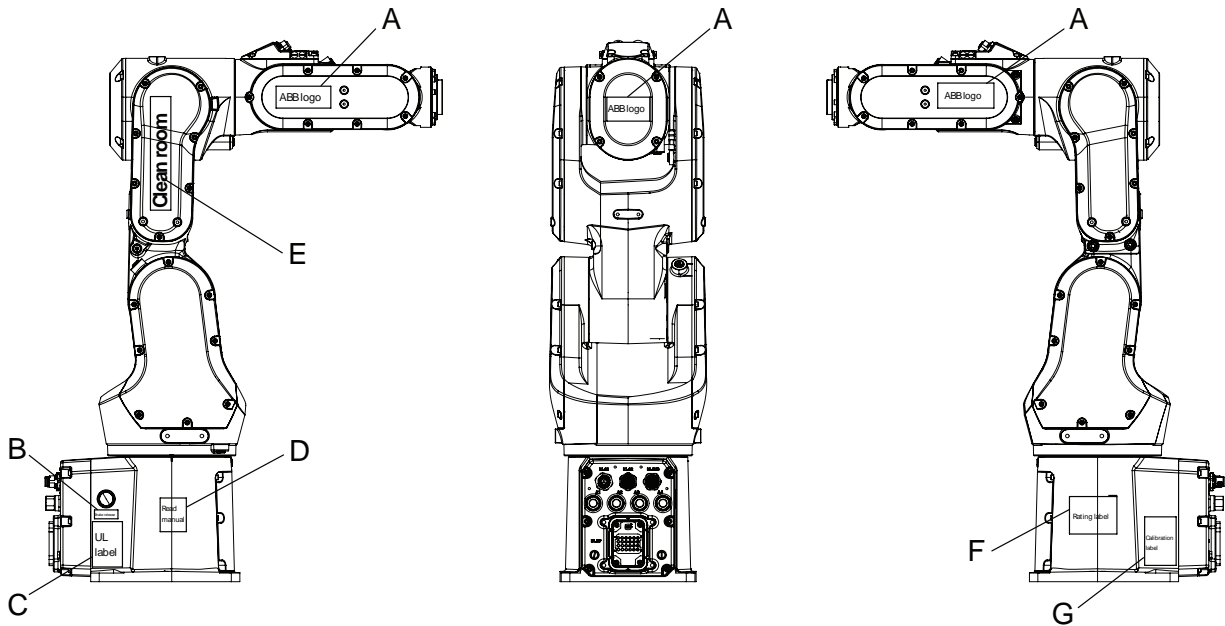

xx1800003316

A	ABB logo
B	Instruction label Brake release
C	UL label
D	Read manual label, also specifying warning labels
E	Clean Room label
F	Rating label, CE label and AbsAcc label
G	Calibration label

Required tools and equipment

Visual inspection, no tools are required.

Continues on next page

4 Maintenance

4.4.1 Inspecting the information labels

Continued

Inspecting, labels

	Action	Note
1	 DANGER Turn off all: <ul style="list-style-type: none">• electric power supply• hydraulic pressure supply• air pressure supply to the robot, before entering the safeguarded space.	
2	Inspect the labels, located as shown in the figures.	
3	Replace any missing or damaged labels.	

4.4.2 Inspecting the robot cabling

Introduction



CAUTION

For robots with protection type Clean Room

Always read the specific instructions before doing any repair work, see [Cut the paint or surface on the robot before replacing parts on page 124](#)

Location of robot cabling

The robot cabling comprises the cabling between the robot and controller cabinet.

Required tools and equipment

Visual inspection, no tools are required.

Other tools and procedures may be required if the spare part needs to be replaced. These are specified in the replacement procedure.

Inspection, robot cabling

Use this procedure to inspect the robot cabling.

	Action	Note
1	 DANGER Turn off all: <ul style="list-style-type: none"> • electric power supply to the robot • hydraulic pressure supply to the robot • air pressure supply to the robot Before entering the robot working area.	
2	Visually inspect: <ul style="list-style-type: none"> • the control cabling between the robot and control cabinet Look for abrasions, cuts or crush damage.	
3	Replace the cabling if wear or damage is detected.	

4 Maintenance

4.4.3 Inspecting timing belts

4.4.3 Inspecting timing belts

Introduction



CAUTION

Always read the section "General procedures" before doing any repair work.
Cut the paint or surface on the robot before replacing parts on page 124.

Location of timing belts



Note

It is recommended to inspect the axis-1 and axis-4 timing belts when replacing the motors.

The timing belts are located as shown in the figures.

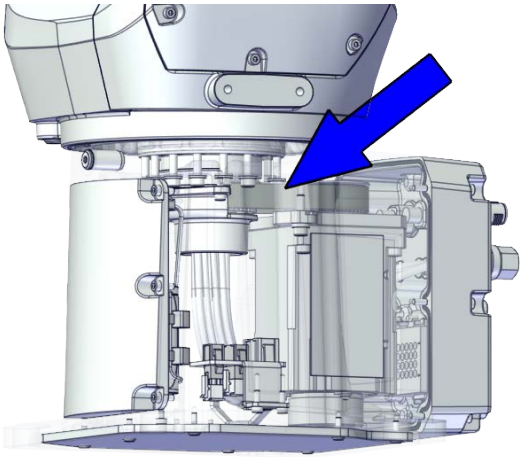
Axis	Location
1	 xx1800002457

Continues on next page

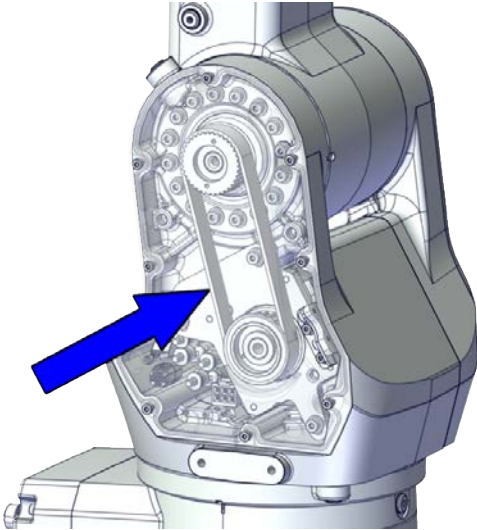
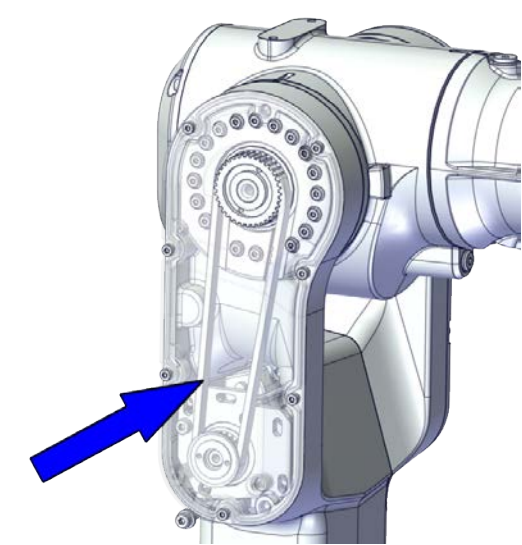
Axis	Location
2	 <p>Diagram showing the internal mechanism of Axis 2, highlighting the timing belt location with a blue arrow. The diagram is labeled xx1800002458.</p>
3	 <p>Diagram showing the internal mechanism of Axis 3, highlighting the timing belt location with a blue arrow. The diagram is labeled xx1800002459.</p>

4 Maintenance

4.4.3 Inspecting timing belts

Continued

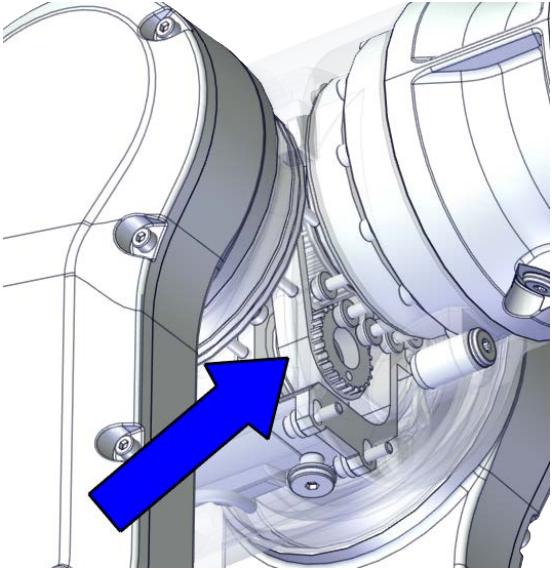
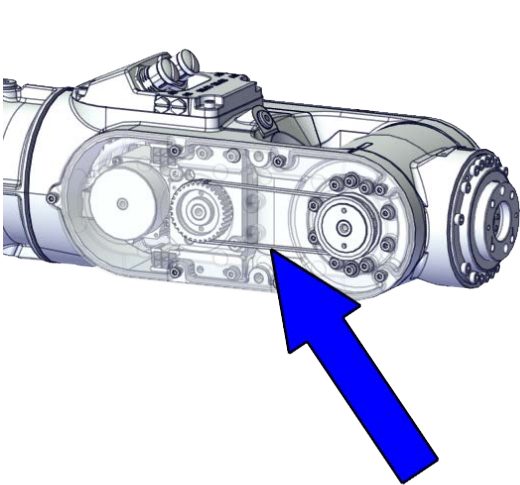
Axis	Location
4	 <p>xx1800002460</p>
5	 <p>xx1800002461</p>

Continues on next page

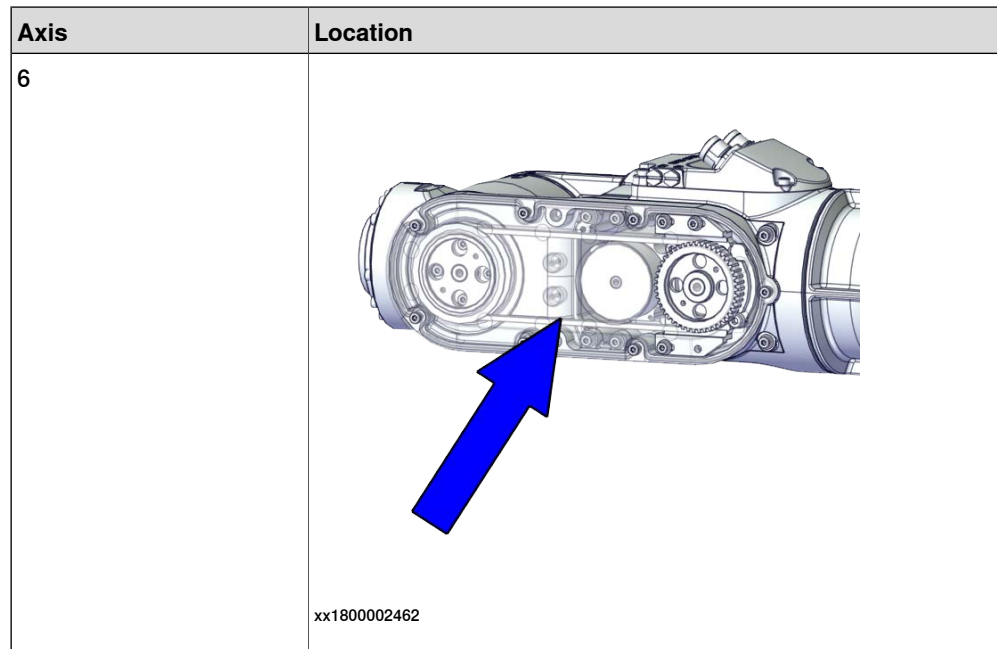

Required tools and equipment

Equipment	Note
Standard toolkit	The content is defined in the section Standard toolkit on page 733 .
Other tools and procedures may be required if the spare part needs to be replaced. These are specified in the replacement procedure.	

Timing belt tension

The table describes the timing belt tension.

Axis	Force		Frequency	
	Used timing belt ⁱ	New timing belt	Used timing belt ⁱ	New timing belt
Axis 1	58.24-63.56 N	83.2-90.8 N ⁱⁱ	255-273 Hz ⁱⁱ	281-359 Hz
Axis 2	68.18-75.04 N ⁱⁱ	97.4-107.2 N	163-174 Hz	180-229 Hz ⁱⁱ
Axis 3	21.7-23.94 N ⁱⁱ	31-34.2 N	102-109 Hz	113-143 Hz ⁱⁱ
Axis 4	20.09-22.05 N	28.7-31.5 N	285-304 Hz ⁱⁱ	314-400 Hz ⁱⁱ
Axis 5	13.58-14.84 N ⁱⁱ	19.4-21.2 N	151-162 Hz	167-213 Hz ⁱⁱ
Axis 6	8.96-9.8 N ⁱⁱ	12.8-14	81.3-86.9 Hz	90-114 Hz ⁱⁱ

ⁱ Used belt is the one having been installed and used for more than 12 hours. Compared with the new timing belt, the force value decreases 15% and the frequency value decreases 28% when the timing belt has been installed and used for more than 12 hours but less than 150 hours. When the timing belt has been installed and used for more than 150 hours, both the force and frequency values decrease 30%.

ⁱⁱ The value range is only for reference.

Continues on next page

4 Maintenance

4.4.3 Inspecting timing belts

Continued

Inspecting timing belts

Use this procedure to inspect timing belts.

	Action	Information
1	 DANGER Turn off all: <ul style="list-style-type: none">• electric power supply• hydraulic pressure supply• air pressure supply to the robot, before entering the robot working area.	
2	Gain access to each <i>timing belt</i> by removing the cover.	
3	Check the timing belts for damage or wear.	
4	Check the <i>timing belt pulleys</i> for damage.	
5	If any damage or wear is detected, the part must be replaced!	
6	Use a sonic tension meter to measure the timing belt tension. If the belt has no tension, adjust it!	See Timing belt tension on page 107 .

4.5 Lubricating activities

4.5.1 Lubricating the cable package

Location of the cable package

The IRB 1100 main cable package has two segments, upper and lower. Inside the swing there is a division point.

The cable packages are located as shown in the figure.

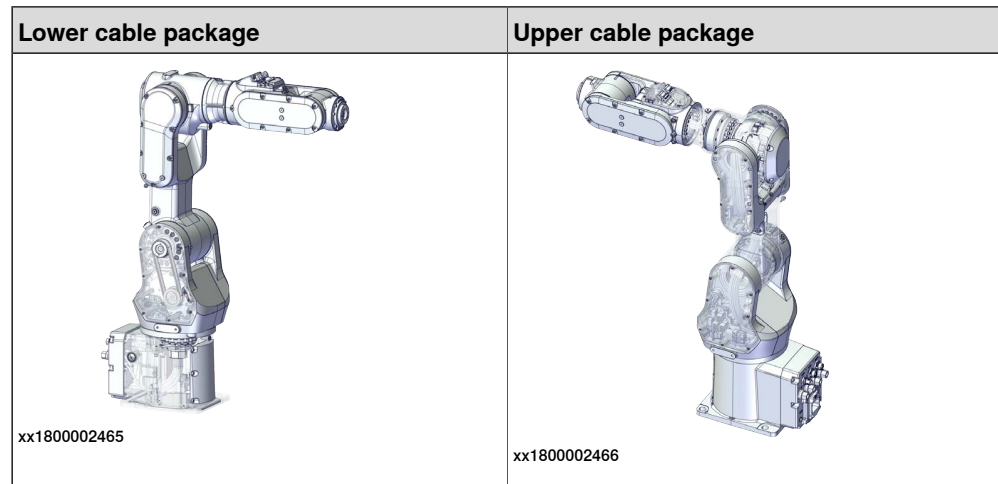

Required tools and equipment

Equipment	Note
Standard toolkit	The content is defined in the section Standard toolkit on page 733 .
Other tools and procedures may be required if the spare part needs to be replaced. These are specified in the replacement procedure.	

Required consumables

Consumable	Article number	Note
Grease	3HAC029132-001	FM 222

Lubricating the cable package

Use this procedure to lubricate the cable package.

	Action	Information
1	 <p>DANGER</p> <p>Turn off all:</p> <ul style="list-style-type: none"> • electric power supply • hydraulic pressure supply • air pressure supply <p>to the robot, before entering the robot working area.</p>	

Continues on next page

4 Maintenance

4.5.1 Lubricating the cable package

Continued

	Action	Information
2	Gain access to the cable package by removing the covers.	
3	Check the cable package for damage or wear.	
4	If any damage or wear is detected, the part must be replaced!	See Replacing the upper cable package on page 127 and Replacing the lower cable package on page 176 .
5	Apply grease to the cable package, cover all moving area of the package.	
6	Apply grease to the covers that have contacting area with the cable package.	

4.6 Replacing/changing activities

4.6.1 Replacing the battery pack

Location of the battery pack

The battery pack is located as shown in the figure.

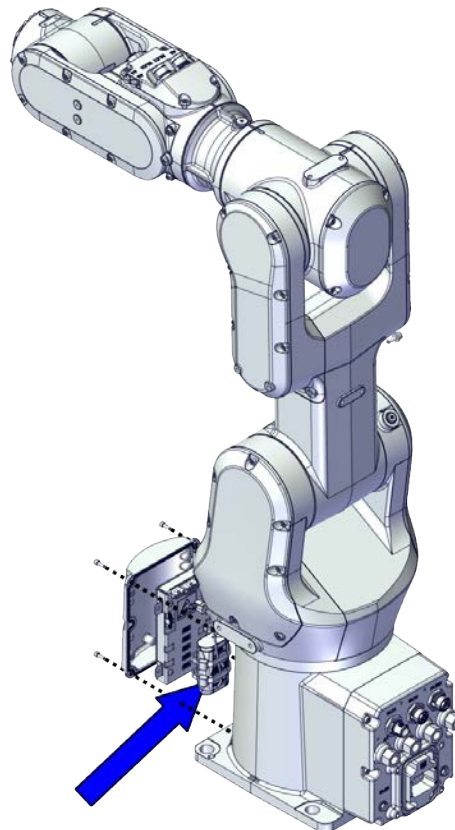

xx1800002463

Required spare parts



Note

The spare part numbers that are listed in the table can be out of date. See the latest spare parts of the IRB 1100 via myABB Business Portal, www.abb.com/myABB.

Spare part	Article number	Note
Battery pack	3HAC044075-001	Battery includes protection circuits. Only replace with the specified spare part or an ABB-approved equivalent.

Continues on next page

4 Maintenance

4.6.1 Replacing the battery pack

Continued

Required tools and equipment

Equipment	Article number	Note
Standard toolkit	-	Content is defined in section Standard toolkit on page 733 .
Calibration tool box, Axis Calibration	3HAC074119-001	Delivered as a set of calibration tools. Required if Axis Calibration is the valid calibration method for the robot. The tool box also includes a unique calibration pin for IRB 1100 to be fitted to the tool flange during calibration of axis 6.
24 VDC power supply	-	Used to release the motor brakes.

Required consumables

Consumable	Article number	Note
Cable straps	-	
Grease	3HAC029132-001	FM 222



Removing the battery pack

Use these procedures to remove the battery pack.

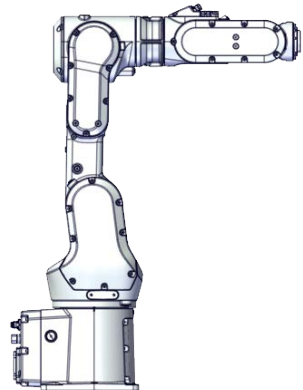

Preparations before removing the battery pack

	Action	Note
1	Decide which calibration routine to use, and take actions accordingly prior to beginning the repair procedure.	
2	Jog all axes to zero position.	 xx1800003288

Continues on next page

	Action	Note
3	 DANGER Turn off all: <ul style="list-style-type: none"> • electric power supply • hydraulic pressure supply • air pressure supply to the robot, before entering the safeguarded space.	
4	 CAUTION For robots with protection type Clean Room Always cut the paint with a knife and grind the paint edge when disassembling parts of the robot! See Cut the paint or surface on the robot before replacing parts on page 124 .	

Disconnecting the SMB connectors





	Action	Note
1	 DANGER Make sure that all supplies for electrical power, hydraulic pressure, and air pressure are turned off.	
2	 ELECTROSTATIC DISCHARGE (ESD) The unit is sensitive to ESD. Before handling the unit read the safety information in section The unit is sensitive to ESD on page 49 .	
3	 CAUTION For robots with protection type Clean Room Always cut the paint with a knife and grind the paint edge when disassembling parts of the robot! See Cut the paint or surface on the robot before replacing parts on page 124 .	

Continues on next page

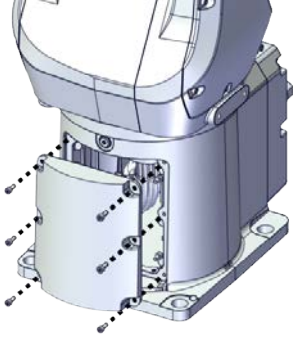

4 Maintenance

4.6.1 Replacing the battery pack

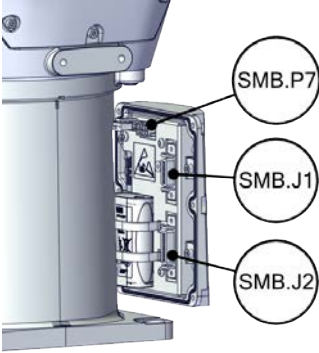
Continued

	Action	Note
4	<p>Remove the SMB cover attachment screws and carefully open the cover.</p> <p> CAUTION</p> <p>Clean cover from metal residues before opening. Metal residues can cause shortage on the boards which can result in hazardous failures.</p> <p> CAUTION</p> <p>There are cabling attached to the cover. The cover cannot be removed completely until the connectors are removed.</p>	 <p>xx1800002467</p>
5	<p>Disconnect the connectors.</p> <ul style="list-style-type: none"> • SMB.P7 • SMB.J1 • SMB.J2 <p> Tip</p> <p>Take photos of the connector and cable position before disconnecting them, to have as a reference when reconnecting.</p>	 <p>xx1800002468</p>
6	Remove the SMB cover completely from the base.	

Removing the battery pack

	Action	Note
1	<p> DANGER</p> <p>Make sure that all supplies for electrical power, hydraulic pressure, and air pressure are turned off.</p>	
2	<p> ELECTROSTATIC DISCHARGE (ESD)</p> <p>The unit is sensitive to ESD. Before handling the unit read the safety information in section The unit is sensitive to ESD on page 49.</p>	
3	<p> CAUTION</p> <p>For robots with protection type Clean Room</p> <p>Always cut the paint with a knife and grind the paint edge when disassembling parts of the robot! See Cut the paint or surface on the robot before replacing parts on page 124.</p>	

Continues on next page

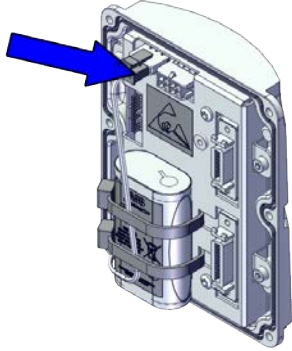
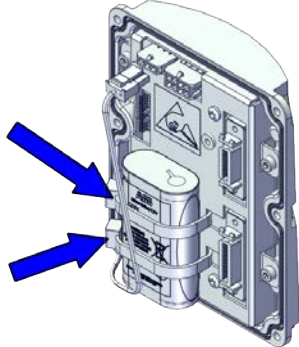
	Action	Note
4	Disconnect the battery cable.	 xx1800002469
5	Remove the battery pack by cutting the cable strap.	 xx1800002470

Refitting the battery pack

Use these procedures to refit the battery pack.

Refitting the battery pack

	Action	Note
1	 ELECTROSTATIC DISCHARGE (ESD) The unit is sensitive to ESD. Before handling the unit read the safety information in section The unit is sensitive to ESD on page 49 .	
2	For robots with protection type Clean Room: Clean the joints that have been opened and wipe the parts free from particles with spirit on a lint free.	

Continues on next page

4 Maintenance

4.6.1 Replacing the battery pack

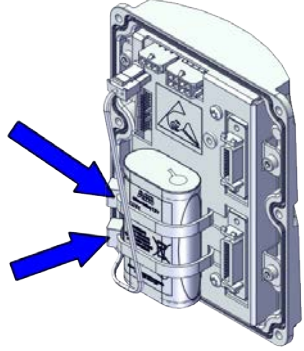
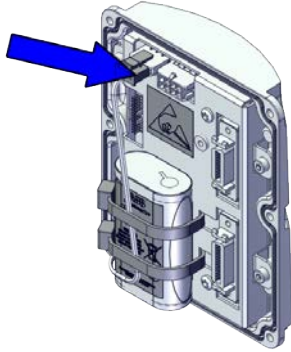

Continued

	Action	Note
3	Secure the battery pack using the cable strap.	 xx1800002470
4	Reconnect the battery cable.	 xx1800002469

Reconnecting the SMB connectors

	Action	Note
1	 ELECTROSTATIC DISCHARGE (ESD) The unit is sensitive to ESD. Before handling the unit read the safety information in section The unit is sensitive to ESD on page 49 .	
2	For robots with protection type Clean Room Clean the joints that have been opened and wipe the parts free from particles with spirit on a lint free.	

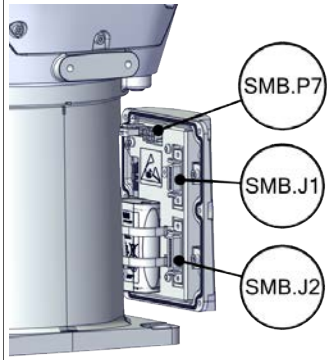
Continues on next page

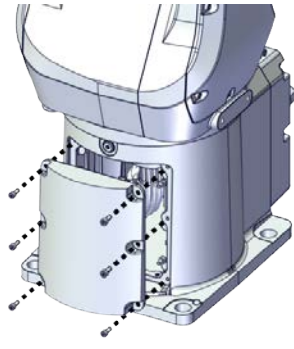
	Action	Note
3	<p>Reconnect the connectors.</p> <ul style="list-style-type: none"> • SMB.P7 • SMB.J1 • SMB.J2 <p> Tip</p> <p>See the number markings on the connectors for help to find the corresponding connector.</p>	<p>Tightening torque: 0.3 Nm</p>  <p>xx1800002468</p>
4	<p>Route and secure the cabling with cable straps.</p> <p> CAUTION</p> <p>Correct cable routing is highly important. If the cables are routed and secured incorrectly the cables can be damaged.</p>	
5	<p>Refit the SMB cover to the base.</p>	<p>Screw: M3x8 12.9 Lafre 2C2B/FC6.9 (6 pcs)</p> <p>Tightening torque: 1.2 Nm</p>  <p>xx1800002467</p>

Concluding procedure

	Action	Note
1	<p>For robots with protection type Clean Room: Clean and paint the joints that have been opened. See Cut the paint or surface on the robot before replacing parts on page 124.</p> <p> Note</p> <p>After all repair work, wipe the Clean Room robot free from particles with spirit on a lint free cloth.</p>	
2	<p>Recalibrate the robot.</p>	<p>Calibration is detailed in section Calibration on page 685.</p>

Continues on next page

4 Maintenance

4.6.1 Replacing the battery pack

Continued

	Action	Note
3	 DANGER Make sure all safety requirements are met when performing the first test run. See Test run after installation, maintenance, or repair on page 91 .	

5 Repair

5.1 Introduction

Structure of this chapter

This chapter describes repair activities for the IRB 1100. Each procedure contains the information required to perform the activity, for example spare parts numbers, required special tools, and materials.



WARNING

Repair activities not described in this chapter must only be carried out by ABB.

Report replaced units



Note

When replacing a part on the IRB 1100, report to your local ABB the serial number, the article number, and the revision of both the replaced unit and the replacement unit.

This is particularly important for safety equipment to maintain the safety integrity of the installation.

Safety information

Make sure to read through the chapter [Safety on page 17](#) before commencing any service work.



Note

The robot should be secured with the transportation brackets during removing from/refitting to the foundation.



Note

If the IRB 1100 is connected to power, always make sure that the IRB 1100 is connected to protective earth and a residual current device (RCD) before starting any repair work.

For more information see:

- *Product manual - OmniCore C30*
- *Product manual - OmniCore C90XT*
- *Product manual - OmniCore E10*

5 Repair

5.2.1 Mounting instructions for sealings

5.2 General procedures

5.2.1 Mounting instructions for sealings

General

This section describes how to mount different types of sealings.

Equipment

Consumable	Article number	Note
Grease	3HAC031695-001	Harmonic Grease 4B No.2 Used to lubricate the seals.

Rotating sealings

The following procedures describe how to fit rotating sealings.



CAUTION

Please observe the following before commencing any assembly of sealings:

- Protect the sealing during transport and mounting, especially the main lip on radial sealings.
- Keep the sealing in its original wrappings or protect it well before actual mounting.
- The fitting of sealings and gears must be carried out on clean workbenches.
- Use a protective sleeve for the main lip during mounting, when sliding over threads, keyways or other sharp edges.
- Do not lubricate a static side of a sealing with grease, since this may result in movement of the sealing during operation.

The only exception for lubrication of static sides of a sealing, is to use P-80 rubber lubrication gel against certain aluminium surfaces. If usage of P-80 is relevant, it is stated in the repair procedures.

Radial sealings

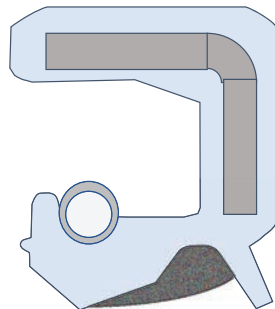

A radial sealing consists of a flexible rubber lip bonded to a rigid metal case. Only one side of the sealing is static with a metal insert.



xx2300000433

Continues on next page

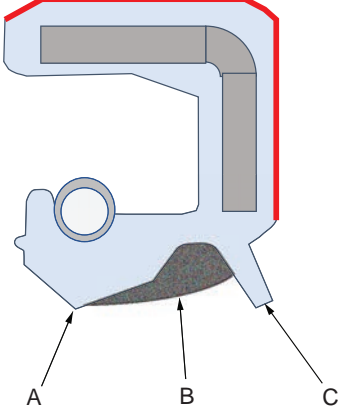
5.2.1 Mounting instructions for sealings
Continued

	Action	Note
1	Check the sealing to ensure that: <ul style="list-style-type: none"> The sealing is of the correct type. There is no damage on the main lip. 	
2	Inspect the shaft surface before mounting. If scratches or damage are found, the shaft must be replaced since it may result in future leakage. Do not try to grind or polish the shaft surface to get rid of the defect.	
3	Lubricate the sealing with grease just before fitting. (Not too early - there is a risk of dirt and foreign particles adhering to the sealing.) Fill 2/3 of the space between the dust lip and the main lip with grease. If the sealing is without dust lip, just lubricate the main lip with a thin layer of grease.	<p>Article number is specified in Equipment on page 120.</p>  <p>xx200000071</p> <p>A Main lip B Grease C Dust lip</p> <p> Note</p> <p>Ensure that no grease is applied to the red marked surface.</p>

Continues on next page

5 Repair

5.2.1 Mounting instructions for sealings

Continued

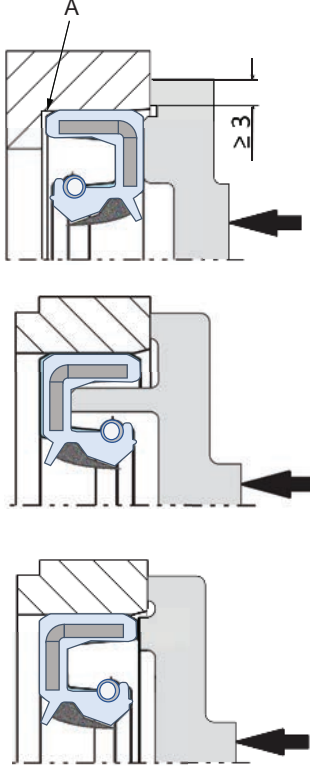
	Action	Note
4	<p>Mount the sealing correctly with a mounting tool. Never hammer directly on the sealing as this may result in leakage.</p>	 <p>xx2000000072</p> <p>A Gap</p>
5	<p>Make sure that no grease is left on the robot surface.</p>	

Flange sealings and static sealings

The following procedure describes how to fit flange sealings and static sealings.

	Action
1	<p>Check the flange surfaces. They must be even and free from pores. It is easy to check flatness using a gauge on the fastened joint (without sealing compound). If the flange surfaces are defective, the parts may not be used because leakage could occur.</p>
2	<p>Clean the surfaces properly in accordance with the recommendations of ABB.</p>
3	<p>Distribute the sealing compound evenly over the surface.</p>
4	<p>Tighten the screws evenly when fastening the flange joint.</p>

O-rings

The following procedure describes how to fit o-rings.

	Action	Note
1	<p>Ensure that the correct o-ring size is used.</p>	
2	<p>Check the o-ring for surface defects, burrs, shape accuracy, or deformation.</p>	<p>Defective o-rings, including damaged or deformed o-rings, may not be used.</p>

Continues on next page

	Action	Note
3	Check the o-ring grooves and mating surfaces. They should be free of pores, contamination and obvious scratches/damage.	
4	Lubricate the o-ring with grease.	
5	Tighten the screws evenly while assembling.	
6	Check that the o-ring is not squashed outside the o-ring groove.	
7	Make sure that no grease is left on the robot surface.	

5 Repair

5.2.2 Cut the paint or surface on the robot before replacing parts

5.2.2 Cut the paint or surface on the robot before replacing parts

General

Follow the procedures in this section whenever breaking the paint of the robot during replacement of parts.

For robots with protection type Clean Room

When replacing parts on the robot, it is important to make sure that after the replacement, no particles will be emitted from the joint between the structure and the new part, and that the easy cleaned surface is retained.

Required equipment

Equipment	Spare parts	Note
Sealing compound	3HAC026759-001	Sikaflex 521 FC. Color white.
Tooling pin		Width 6-9 mm, made of wood.
Cleaning agent		Ethanol
Knife		
Lint free cloth		
Touch up paint Clean Room/Hygienic	3HAC036639-001	White

Removing

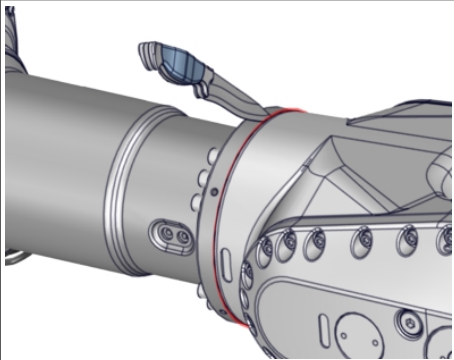
	Action	Description
1	Cut the paint with a knife in the joint between the part that will be removed and the structure, to avoid that the paint cracks.	 xx230000950
2	Carefully grind the paint edge that is left on the structure to a smooth surface.	



Refitting

	Action	Description
1	Before the parts are refitted, clean the joint so that it is free from oil and grease.	Use ethanol on a lint free cloth.
2	Place the tooling pin in hot water.	

Continues on next page

5.2.2 Cut the paint or surface on the robot before replacing parts

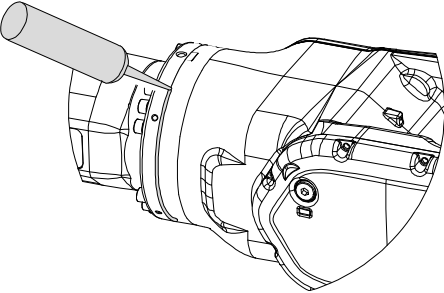
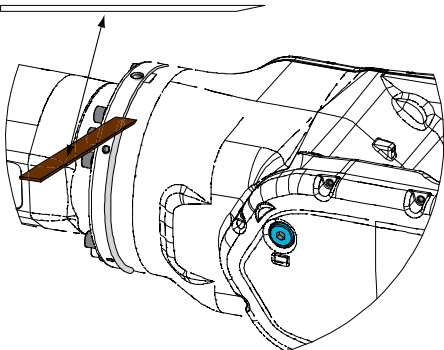
Continued

	Action	Description
3	Seal all refitted joints with sealing compound.	 <p>xx0900000122</p>
4	Use the tooling pin to even out the surface of the sealing compound.	 <p>xx0900000125</p>
5	For robots with protection type Clean Room Wait 10 minutes.	For robots with protection type Clean Room Sikaflex 521FC skin dry time (10 minutes).
6	Use Touch up paint Clean Room/Hygienic, white to paint any damaged surfaces.  Note Always read the instruction in the product data sheet in the paint repair kit for Clean Room/Hygienic.	3HAC036639-001



Note

After all repair work, wipe the robot free from particles with spirit on a lint free cloth.

5 Repair

5.3 Cable harness

5.3 Cable harness

General

The IRB 1100 main cable package has two segments, upper and lower. Inside the swing there is a division point.

The lower cable package runs from the base and up through into the swing. The upper cable package runs from the swing, up through the lower arm, into the housing and then into the wrist.

The main cable package includes the cabling for all the six motors. Optional air hoses, CP/CS cabling and Ethernet cabling can also be included.

As standard feature, the connector interface is located at the rear of the base. The interface can also be bottom mounted, as an option. This section describes both configurations.

Continues on next page

5.3.1 Replacing the upper cable package

Location of the upper cable package

The upper cable package is located as shown in the figure.

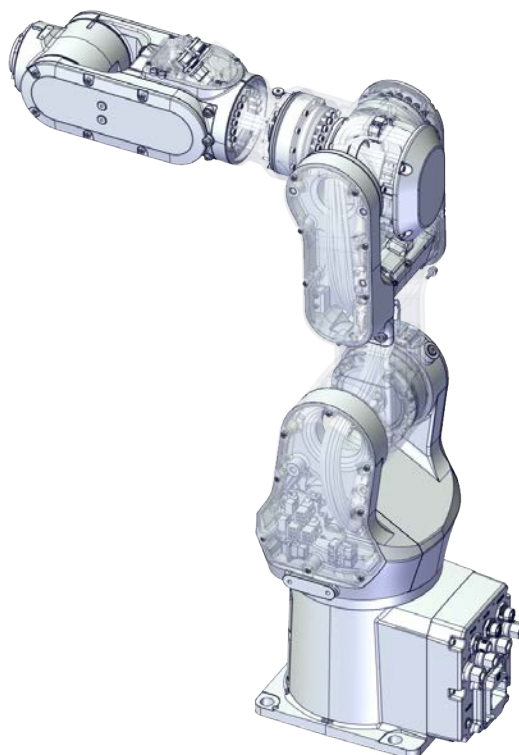

xx1800002466

Required spare parts



Note

The spare part numbers that are listed in the table can be out of date. See the latest spare parts of the IRB 1100 via myABB Business Portal, www.abb.com/myABB.

Spare part	Article number	Note
Upper cable harness, basic	3HAC060419-001	Used with IRB 1100-4/0.475.
Upper cable harness (CP/CS and air hose, without Ethernet)	3HAC060419-002	Used with IRB 1100-4/0.475.
Upper cable harness (CP/CS and air hose, with Ethernet)	3HAC060419-003	Used with IRB 1100-4/0.475.
Extension upper cable harness, basic	3HAC060416-001	Used with IRB 1100-4/0.58.
Extension upper cable harness (CP/CS and air hose, without Ethernet)	3HAC060416-002	Used with IRB 1100-4/0.58.
Extension upper cable harness (CP/CS and air hose, with Ethernet)	3HAC060416-003	Used with IRB 1100-4/0.58.

Continues on next page

5 Repair

5.3.1 Replacing the upper cable package

Continued

Spare part	Article number	Note
Process hub, basic	3HAC069094-001	
Process hub, basic, Clean Room	3HAC075509-001	Used with protection type Clean Room.
Process hub (CP/CS and air hose, without Ethernet)	3HAC069095-001	
Process hub, Clean Room (CP/CS and air hose, without Ethernet)	3HAC075510-001	Used with protection type Clean Room.
Process hub (CP/CS and air hose, with Ethernet)	3HAC069096-001	
Process hub, Clean Room (CP/CS and air hose, with Ethernet)	3HAC075511-001	Used with protection type Clean Room.
Motor with flange, axis 2	3HAC083588-001	.
Timing belt, axis 2	3HAC061935-001	
Motor with flange, axis 3	3HAC083587-001	
Timing belt, axis 3	3HAC061936-001	
Motor with flange, axis 6	3HAC083584-001	
Timing belt, axis 6	3HAC061939-001	
Swing cover	3HAC069051-001	
Swing cover, Clean Room	3HAC075498-001	Used with protection type Clean Room.
Swing support cover	3HAC069052-001	
Swing support cover, Clean Room	3HAC075500-001	Used with protection type Clean Room.
Wrist cover	3HAC069061-001	
Wrist cover, Clean Room	3HAC075507-001	Used with protection type Clean Room.
Housing cover	3HAC069054-001	
Housing cover, Clean Room	3HAC075501-001	Used with protection type Clean Room.
Lower arm cover	3HAC069057-001	
Lower arm cover, Clean Room	3HAC075503-001	Used with protection type Clean Room.
Lower arm support cover	3HAC069059-001	
Lower arm support cover, Clean Room	3HAC075505-001	Used with protection type Clean Room.
Gasket for swing cover	3HAC061959-003	Used with protection class IP67 and protection type Clean Room. Replace if damaged.
Gasket for swing support cover	3HAC065317-001	Used with protection class IP67 and protection type Clean Room. Replace if damaged.
Gasket for lower arm cover	3HAC061959-006	Used with protection class IP67 and protection type Clean Room. Replace if damaged.

Continues on next page

5.3.1 Replacing the upper cable package
Continued

Spare part	Article number	Note
Gasket for lower arm support cover	3HAC065331-001	Used with protection class IP67 and protection type Clean Room. Replace if damaged.
Gasket for housing cover	3HAC061959-007	Used with protection class IP67 and protection type Clean Room. Replace if damaged.
Gasket for wrist cover	3HAC061959-009	Used with protection class IP67 and protection type Clean Room. Replace if damaged.
Cooling pad for axis-1 and -2 motors	3HAC071020-001	Cooling pads are wear parts. One cooling pad sheet contains 6 pieces of small pad. Replace if damaged with one piece each time.
Cooling pad for axis-3 and -4 motors	3HAC071021-001	Cooling pads are wear parts. One cooling pad sheet includes 10 pieces of small pad. Replace if damaged with one piece each time.
Washer	3HAC063985-001	9x4.3x1, Steel
Washer	3HAC064765-001	7x3.2x1.5, Steel
Rubber sealing washer on extender unit	3HAC067995-001	Used with protection class IP67 and protection type Clean Room. Replace if damaged.
Plug screw	3HAC064146-001	Used with protection classes IP40 and IP67. Replace if damaged.
Plug screw, Clean Room	3HAC070309-001	Used with protection type Clean Room. Replace if damaged.

Required tools and equipment

Equipment	Article number	Note
Standard toolkit	-	Content is defined in section Standard toolkit on page 733 .
Calibration tool box, Axis Calibration	3HAC074119-001	Delivered as a set of calibration tools. Required if Axis Calibration is the valid calibration method for the robot. The tool box also includes a unique calibration pin for IRB 1100 to be fitted to the tool flange during calibration of axis 6.
24 VDC power supply	-	Used to release the motor brakes.
Sonic tension meter	-	Used for measuring the timing belt tension.
Dynamometer	-	Used for measuring the timing belt tension.

Continues on next page

5 Repair

5.3.1 Replacing the upper cable package

Continued

Equipment	Article number	Note
M3x25 eye bolt	-	Included in the special toolkit 3HAC071022-001.
J5.C2 connector assembly tool	-	Included in the special toolkit 3HAC071022-001. Used to remove and refit the J5.C2 connector, if the Ethernet cabling is equipped.

Required consumables

Consumable	Article number	Note
Cable straps	-	
Grease	3HAC029132-001	FM 222
Locking liquid	-	Loctite 2400 (or equivalent Loctite 243)

Deciding calibration routine

Decide which calibration routine to be used, based on the information in the table. Depending on which routine is chosen, action might be required prior to beginning the repair work of the robot, see the table.



Action	Note
<p>1 Decide which calibration routine to use for calibrating the robot.</p> <ul style="list-style-type: none"> Reference calibration. External cable packages (DressPack) and tools can stay fitted on the robot. Fine calibration. All external cable packages (DressPack) and tools must be removed from the robot. 	<p> Note</p> <p>Calibrating axis 6 always requires tools to be removed from the mounting flange (also for reference calibration) since the mounting flange is used for installation of the calibration tool.</p>
<p>If the robot is to be calibrated with reference calibration:</p> <p>Find previous reference values for the axis or create new reference values. These values are to be used after the repair procedure is completed, for calibration of the robot.</p> <p>If no previous reference values exist, and no new reference values can be created, then reference calibration is not possible.</p>	<p>Follow the instructions given in the reference calibration routine on the FlexPendant to create reference values.</p> <p>Creating new values requires possibility to move the robot.</p> <p>Read more about reference calibration for Axis Calibration in Reference calibration routine on page 696.</p>
<p>If the robot is to be calibrated with fine calibration:</p> <p>Remove all external cable packages (DressPack) and tools from the robot.</p>	

Continues on next page

Removing the upper cable package

Use these procedures to remove the upper cable package.

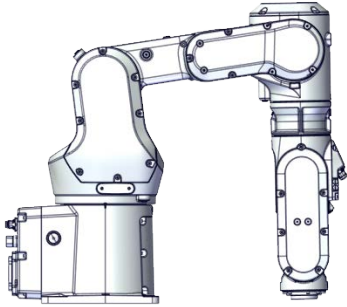
Preparations before removing the upper cable package

	Action	Note
1	Decide which calibration routine to use, and take actions accordingly prior to beginning the repair procedure.	
2	Jog the robot to the specified position: <ul style="list-style-type: none"> • Axis 1: 0° • Axis 2: 110° (IRB 1100-4/0.475) /95° (IRB 1100-4/0.58) • Axis 3: -20° (IRB 1100-4/0.475)/ -6° (IRB 1100-4/0.58) • Axis 4: 0° • Axis 5: 0° • Axis 6: No significance. 	 <p>xx1800003289</p>
3	 <p>DANGER</p> <p>Turn off all:</p> <ul style="list-style-type: none"> • electric power supply • hydraulic pressure supply • air pressure supply <p>to the robot, before entering the safeguarded space.</p>	
4	 <p>CAUTION</p> <p>For robots with protection type Clean Room Always cut the paint with a knife and grind the paint edge when disassembling parts of the robot! See Cut the paint or surface on the robot before replacing parts on page 124.</p>	

Removing the axis-2 motor







	Action	Note
1	 <p>DANGER</p> <p>Make sure that all supplies for electrical power, hydraulic pressure, and air pressure are turned off.</p>	

Continues on next page

5 Repair

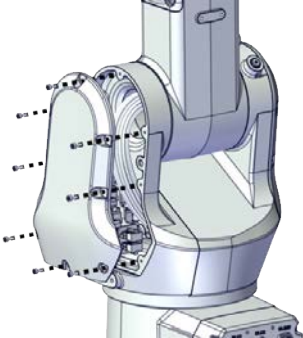

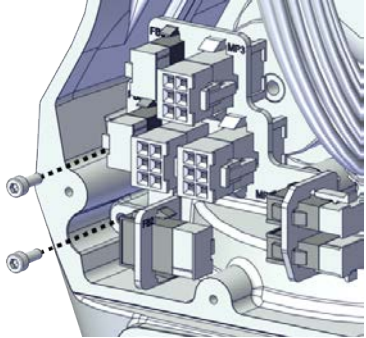
5.3.1 Replacing the upper cable package

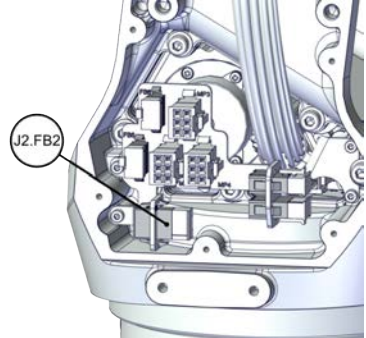
Continued

	Action	Note
2	<p> CAUTION</p> <p>For robots with protection type Clean Room Always cut the paint with a knife and grind the paint edge when disassembling parts of the robot! See Cut the paint or surface on the robot before replacing parts on page 124.</p>	
3	<p> CAUTION</p> <p>Removing motors will release axes. This means the axes can fall down. Make sure axes are well supported before removing motors.</p>	
4	Remove the swing support cover.	 <p>xx1800002488</p>
5	<p>Remove the connector plate.</p> <p> CAUTION</p> <p>Be aware of the cablings that are attached to the connector plate! The connector plate cannot be removed completely until the connectors are removed from the plate.</p>	 <p>xx1800002489</p>
6	<p>Disconnect the connector.</p> <ul style="list-style-type: none"> J2.FB2 <p> Tip</p> <p>Take photos of the connector and cable position before disconnecting them, to have as a reference when reconnecting.</p>	 <p>xx1800002490</p>

Continues on next page

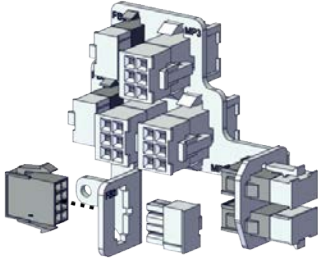
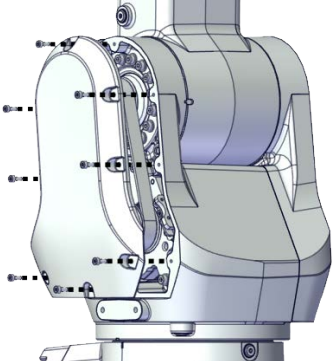
5.3.1 Replacing the upper cable package
Continued

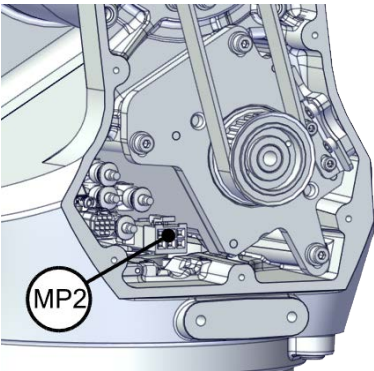
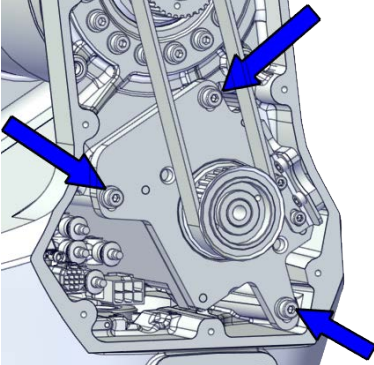

	Action	Note
7	Snap loose and remove the female head of the connector from the connector plate.	 <p>xx1800002491</p>
8	Remove the swing cover.	 <p>xx1800002492</p>
9	Disconnect the connector. <ul style="list-style-type: none"> • MP2  Tip Take photos of the connector and cable position before disconnecting them, to have as a reference when reconnecting.	 <p>xx1800002495</p>
10	Loosen the screws and move the motor slightly to slacken the timing belt.	 <p>xx1800002493</p>

Continues on next page

5 Repair

5.3.1 Replacing the upper cable package

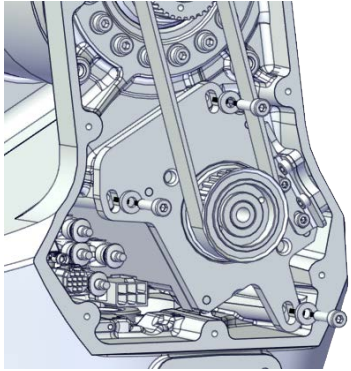
Continued

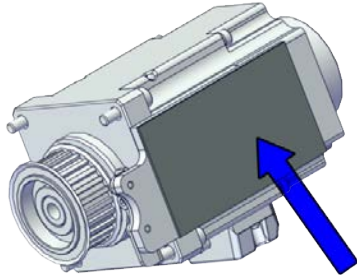
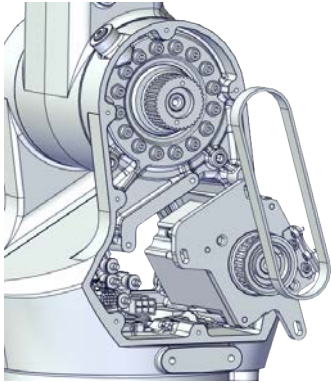

	Action	Note
11	Remove the screws and washers.	 <p>xx1800002494</p>
12	Carefully lift out the motor.  CAUTION A cooling pad is attached to the motor, which may stick to the casting. Always use a plastic sheet with caution to remove the pad from the casting. Pay attention not to scratch the casting or damage the pad.  CAUTION Be aware of the motor cabling. The motor cannot be removed completely until the connector is disconnected, as shown in following step.	Cooling pad location  <p>xx1800003603</p>
13	Remove the timing belt from its groove on the motor.	 <p>xx1800002496</p>

Disconnecting the connectors at the division point



	Action	Note
1	 DANGER Make sure that all supplies for electrical power, hydraulic pressure, and air pressure are turned off.	

Continues on next page

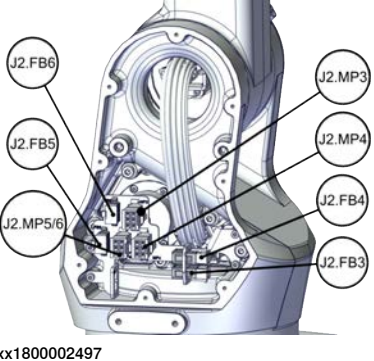
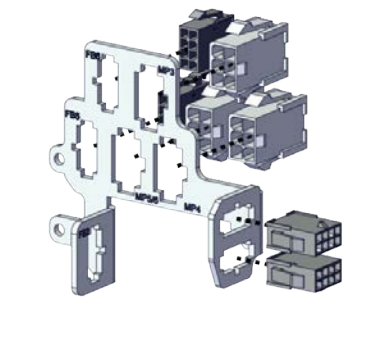
5.3.1 Replacing the upper cable package
Continued

	Action	Note
2	<p> CAUTION</p> <p>For robots with protection type Clean Room Always cut the paint with a knife and grind the paint edge when disassembling parts of the robot! See <i>Cut the paint or surface on the robot before replacing parts on page 124.</i></p>	
3	<p>Disconnect the connectors.</p> <ul style="list-style-type: none"> • J2.FB3,4,5,6 • J2.MP3,4,5/6 <p> Tip</p> <p>Take photos of the connector and cable position before disconnecting them, to have as a reference when reconnecting.</p>	 <p>xx1800002497</p>
4	<p>Snap loose and remove the female head of the connectors from the connector plate.</p>	 <p>xx1800002498</p>

Separating the cable package from the swing

	Action	Note
1	<p> DANGER</p> <p>Make sure that all supplies for electrical power, hydraulic pressure, and air pressure are turned off.</p>	
2	<p> CAUTION</p> <p>For robots with protection type Clean Room Always cut the paint with a knife and grind the paint edge when disassembling parts of the robot! See <i>Cut the paint or surface on the robot before replacing parts on page 124.</i></p>	

Continues on next page



5 Repair

5.3.1 Replacing the upper cable package

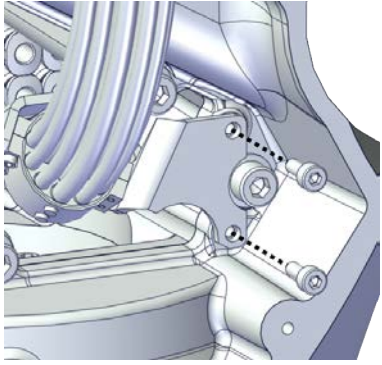
Continued

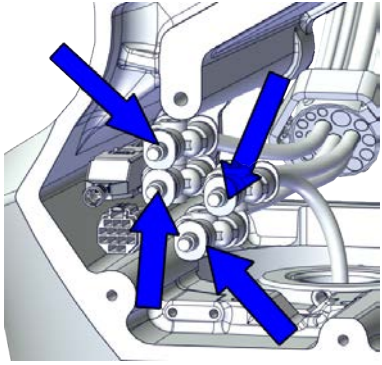

	Action	Note
3	Remove the cable bracket.	 <p>xx1800002499</p>

Disconnecting the air hoses, CP/CS cabling and Ethernet cabling (if equipped)



	Action	Note
1	 DANGER Make sure that all supplies for electrical power, hydraulic pressure, and air pressure are turned off.	
2	 CAUTION For robots with protection type Clean Room Always cut the paint with a knife and grind the paint edge when disassembling parts of the robot! See Cut the paint or surface on the robot before replacing parts on page 124 .	
3	Disconnect the air hoses from the Y-shaped connectors.	 <p>xx1800002500</p>

Continues on next page

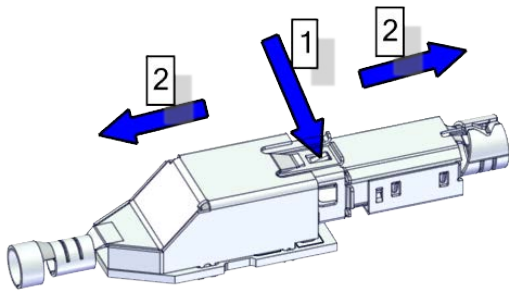
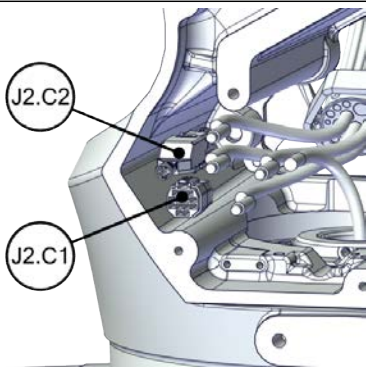
5.3.1 Replacing the upper cable package
Continued

	Action	Note
4	<p>Disconnect the connectors.</p> <ul style="list-style-type: none"> • J2.C1 • J2.C2 <p> Tip</p> <p>Take photos of the connector and cable position before disconnecting them, to have as a reference when reconnecting.</p> <p> Tip</p> <p>The connector clip has to be pressed (1) and pushed forward (2) to separate the J2.C2 (for Ethernet cabling).</p>  <p>xx1800002943</p>	 <p>xx1800002501</p>

Removing the process hub

	Action	Note
1	<p> DANGER</p> <p>Make sure that all supplies for electrical power, hydraulic pressure, and air pressure are turned off.</p>	
2	<p> CAUTION</p> <p>For robots with protection type Clean Room</p> <p>Always cut the paint with a knife and grind the paint edge when disassembling parts of the robot! See Cut the paint or surface on the robot before replacing parts on page 124.</p>	

Continues on next page

5 Repair

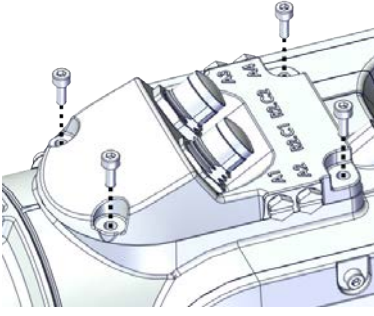
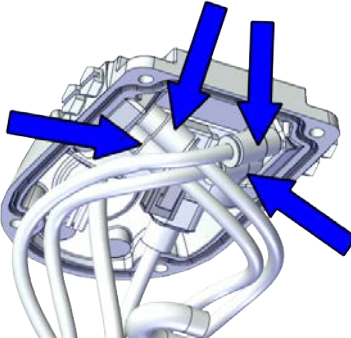
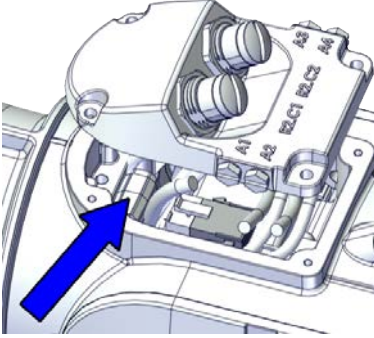
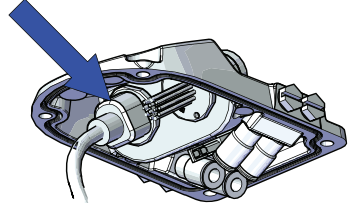

5.3.1 Replacing the upper cable package

Continued



	Action	Note
3	<p>Remove the screws and carefully open the cover.</p> <p> CAUTION</p> <p>Be aware of the cabling that is attached to the cover! The cover can not be removed completely until the connectors are disconnected, as shown in following steps.</p>	 <p>xx1800002944</p>
4	<p>Disconnect the air hoses.</p>	 <p>xx1800002945</p>
5	<p>For robots with CP/CS cabling Disconnect the connector.</p> <ul style="list-style-type: none"> • J5.C1 	 <p>xx1800002947</p>
6	<p>For robots with Ethernet cabling Disconnect the connector J5.C2 using the tool.</p>	<p>J5.C2 connector assembly tool: -</p>  <p>xx1800002948</p>

Continues on next page

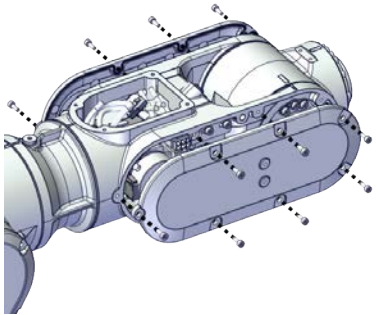
Removing the wrist covers

	Action	Note
1	 DANGER Make sure that all supplies for electrical power, hydraulic pressure, and air pressure are turned off.	
2	 CAUTION For robots with protection type Clean Room Always cut the paint with a knife and grind the paint edge when disassembling parts of the robot! See Cut the paint or surface on the robot before replacing parts on page 124 .	
3	Remove the wrist covers from both sides.	 xx1800002949

Disconnecting the axis-5 motor connectors

	Action	Note
1	 DANGER Make sure that all supplies for electrical power, hydraulic pressure, and air pressure are turned off.	
2	 CAUTION For robots with protection type Clean Room Always cut the paint with a knife and grind the paint edge when disassembling parts of the robot! See Cut the paint or surface on the robot before replacing parts on page 124 .	

Continues on next page



5 Repair

5.3.1 Replacing the upper cable package

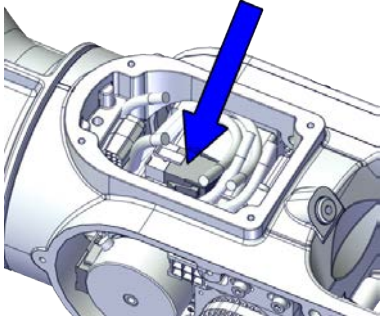
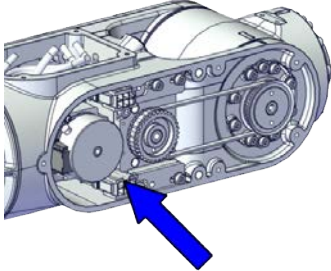
Continued

	Action	Note
3	Access the connector FB5 from the process hub and disconnect the connector.	 xx1800002950
4	Disconnect the connector. <ul style="list-style-type: none"> • MP5 	 xx1800002993

Disconnecting the axis-6 motor connectors



	Action	Note
1	 DANGER Make sure that all supplies for electrical power, hydraulic pressure, and air pressure are turned off.	
2	 CAUTION For robots with protection type Clean Room Always cut the paint with a knife and grind the paint edge when disassembling parts of the robot! See Cut the paint or surface on the robot before replacing parts on page 124.	

Continues on next page

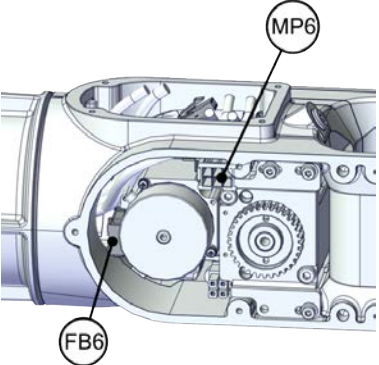
5.3.1 Replacing the upper cable package
Continued

	Action	Note
3	Disconnect the connectors. <ul style="list-style-type: none"> • MP6 • FB6 	 <p>xx1800002994</p>

Removing the axis-6 motor

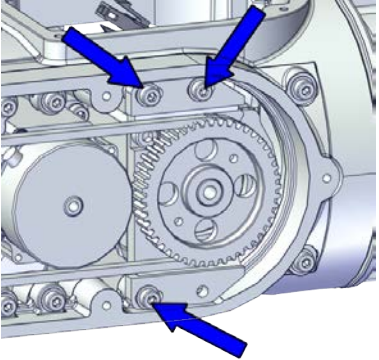
	Action	Note
1	 DANGER Make sure that all supplies for electrical power, hydraulic pressure, and air pressure are turned off.	
2	 CAUTION For robots with protection type Clean Room Always cut the paint with a knife and grind the paint edge when disassembling parts of the robot! See Cut the paint or surface on the robot before replacing parts on page 124.	
3	 CAUTION Removing motors will release axes. This means the axes can fall down. Make sure axes are well supported before removing motors.	
4	Loosen the screws and move the motor slightly to slacken the timing belt.	 <p>xx1800002995</p>

Continues on next page



5 Repair

5.3.1 Replacing the upper cable package

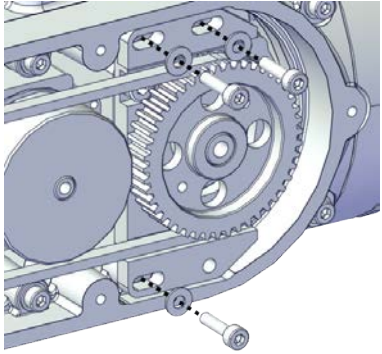
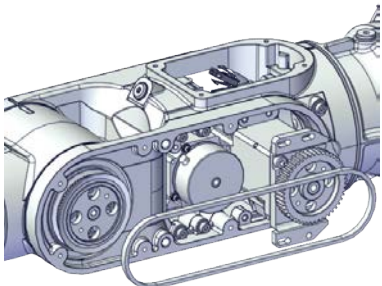
Continued

	Action	Note
5	Remove the screws and washers.	 <p>xx1800002996</p>
6	Carefully lift out the motor.	
7	Remove the timing belt from its groove on the motor.	 <p>xx1800002997</p>

Loosening the cable package from axis-4 gearbox

	Action	Note
1	 DANGER Make sure that all supplies for electrical power, hydraulic pressure, and air pressure are turned off.	
2	 CAUTION For robots with protection type Clean Room Always cut the paint with a knife and grind the paint edge when disassembling parts of the robot! See Cut the paint or surface on the robot before replacing parts on page 124.	

Continues on next page

5.3.1 Replacing the upper cable package
Continued

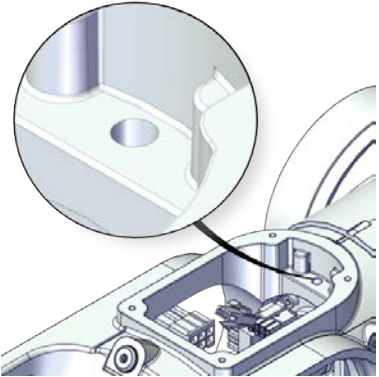
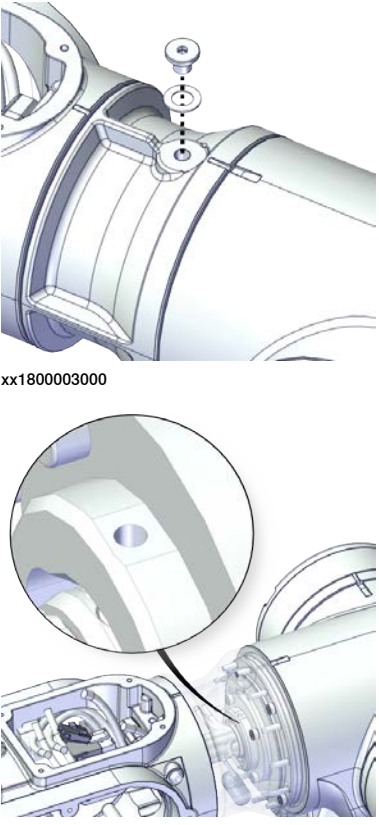
	Action	Note
3	<p>Valid for IRB 1100-4/0.475</p> <p>Access the cable package locking screw on the axis-4 gearbox from the wrist and then loosen the locking screw.</p>	 <p>xx1800003031</p>
4	<p>Remove the plug screw and washer on the extender unit to access the cable package locking screw on the axis-4 gearbox and then loosen the locking screw.</p>	 <p>xx1800003000</p> <p>xx1800003001</p>

Separating the upper cable harness from the axis-2 gearbox

	Action	Note
1	 <p>DANGER</p> <p>Make sure that all supplies for electrical power, hydraulic pressure, and air pressure are turned off.</p>	

Continues on next page



5 Repair

5.3.1 Replacing the upper cable package

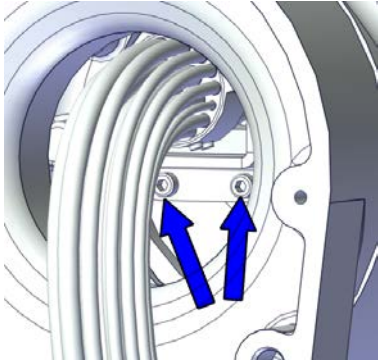
Continued

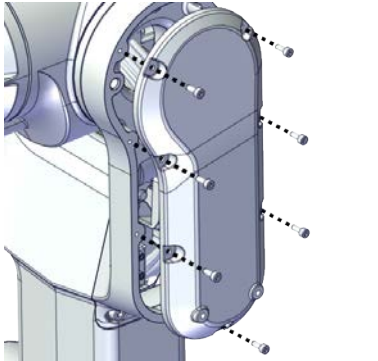

	Action	Note
2	<p> CAUTION</p> <p>For robots with protection type Clean Room Always cut the paint with a knife and grind the paint edge when disassembling parts of the robot! See <i>Cut the paint or surface on the robot before replacing parts on page 124.</i></p>	
3	Remove the cable bracket.	 <p>xx1800003002</p>

Disconnecting the axis-3 motor connectors

	Action	Note
1	<p> DANGER</p> <p>Make sure that all supplies for electrical power, hydraulic pressure, and air pressure are turned off.</p>	
2	<p> CAUTION</p> <p>For robots with protection type Clean Room Always cut the paint with a knife and grind the paint edge when disassembling parts of the robot! See <i>Cut the paint or surface on the robot before replacing parts on page 124.</i></p>	
3	Remove the lower arm support cover.	 <p>xx1800003003</p>

Continues on next page

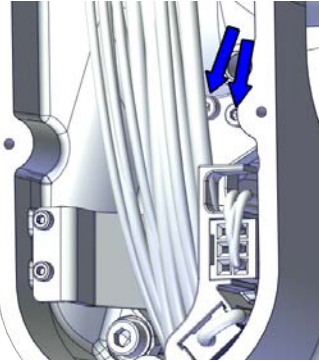
5.3.1 Replacing the upper cable package
Continued

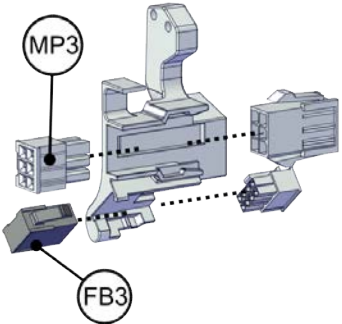
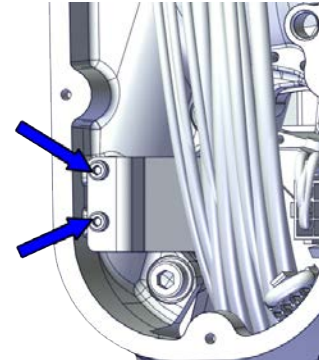
	Action	Note
4	<p>Remove the connector plate.</p> <p> CAUTION</p> <p>Be aware of the cablings that are attached to the connector plate! The connector plate cannot be removed completely until the connectors are removed from the plate, as shown in following step.</p>	 <p>xx1800003004</p>
5	<p>Slide the connectors out of the connector plate and disconnect the connectors.</p> <ul style="list-style-type: none"> • FB3 • MP3 <p> Tip</p> <p>Take photos of the connector and cable position before disconnecting them, to have as a reference when reconnecting.</p>	 <p>xx1800003005</p>
6	<p>Remove the cable bracket.</p>	 <p>xx1800003006</p>

Removing the axis-3 motor



	Action	Note
1	<p> DANGER</p> <p>Make sure that all supplies for electrical power, hydraulic pressure, and air pressure are turned off.</p>	

Continues on next page

5 Repair

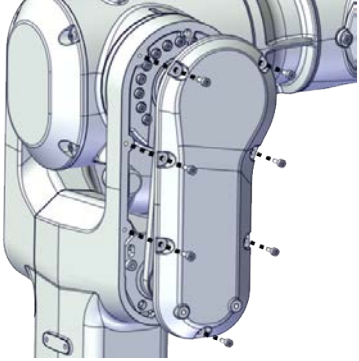
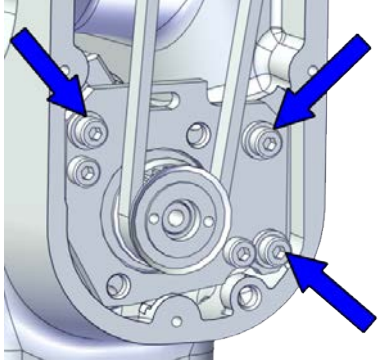

5.3.1 Replacing the upper cable package

Continued

	Action	Note
2	<p> CAUTION</p> <p>For robots with protection type Clean Room Always cut the paint with a knife and grind the paint edge when disassembling parts of the robot! See <i>Cut the paint or surface on the robot before replacing parts on page 124.</i></p>	
3	<p> CAUTION</p> <p>Removing motors will release axes. This means the axes can fall down. Make sure axes are well supported before removing motors.</p>	
4	Remove the lower arm cover.	 <p>xx1800003007</p>
5	Loosen the screws and move the motor slightly to slacken the timing belt.	 <p>xx1800003008</p>

Continues on next page

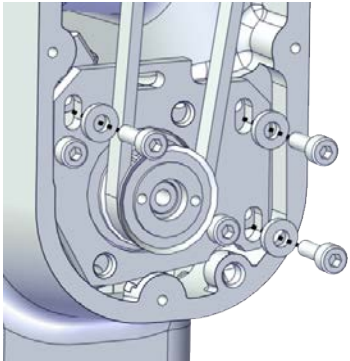
5.3.1 Replacing the upper cable package
Continued

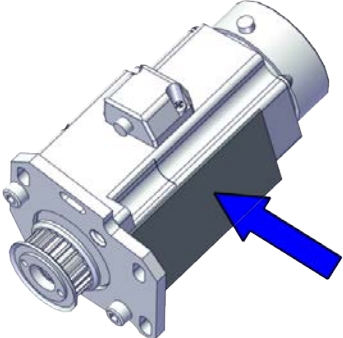
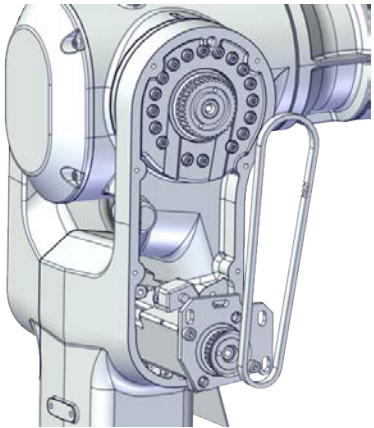
	Action	Note
6	Remove the screws and washers.	 <p>xx1800003009</p>
7	Carefully lift out the motor.  CAUTION A cooling pad is attached to the motor, which may stick to the casting. Always use a plastic sheet with caution to remove the pad from the casting. Pay attention not to scratch the casting or damage the pad.	Cooling pad location  <p>xx1800003604</p>
8	Remove the timing belt from its groove on the motor.	 <p>xx1800003010</p>

Disconnecting the axis-4 motor connectors

	Action	Note
1	 DANGER Make sure that all supplies for electrical power, hydraulic pressure, and air pressure are turned off.	

Continues on next page



5 Repair

5.3.1 Replacing the upper cable package

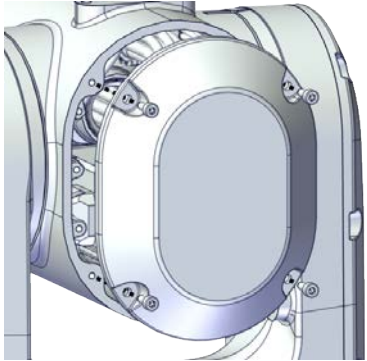
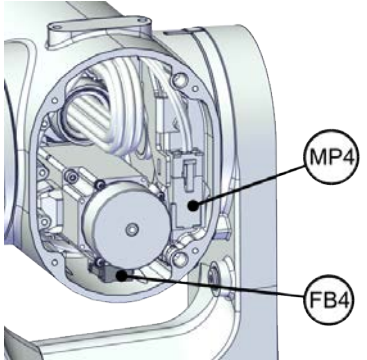
Continued

	Action	Note
2	<p> CAUTION</p> <p>For robots with protection type Clean Room Always cut the paint with a knife and grind the paint edge when disassembling parts of the robot! See Cut the paint or surface on the robot before replacing parts on page 124.</p>	
3	Remove the housing cover.	 <p>xx1800003011</p>
4	<p>Disconnect the motor connectors.</p> <ul style="list-style-type: none"> • FB4 • MP4 	 <p>xx1800003012</p>

Separating the upper cable package from the housing



	Action	Note
1	<p> DANGER</p> <p>Make sure that all supplies for electrical power, hydraulic pressure, and air pressure are turned off.</p>	
2	<p> CAUTION</p> <p>For robots with protection type Clean Room Always cut the paint with a knife and grind the paint edge when disassembling parts of the robot! See Cut the paint or surface on the robot before replacing parts on page 124.</p>	

Continues on next page

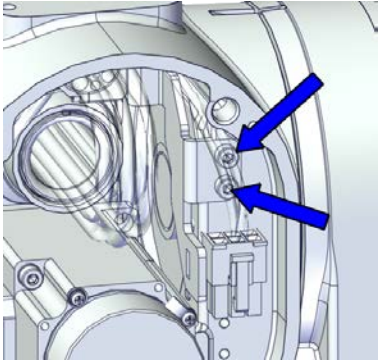
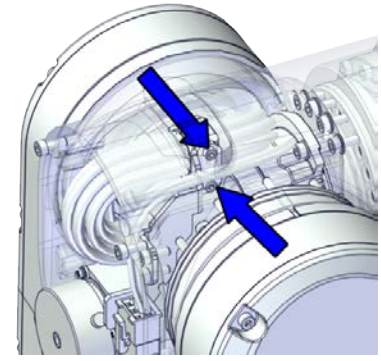
5.3.1 Replacing the upper cable package
Continued

	Action	Note
3	Remove the cable bracket.	 <p>xx1800003013</p>  <p>xx1800003014</p>

Pulling out the upper cable harness

	Action	Note
1	 DANGER Make sure that all supplies for electrical power, hydraulic pressure, and air pressure are turned off.	
2	 CAUTION For robots with protection type Clean Room Always cut the paint with a knife and grind the paint edge when disassembling parts of the robot! See Cut the paint or surface on the robot before replacing parts on page 124 .	

Continues on next page

5 Repair

5.3.1 Replacing the upper cable package

Continued

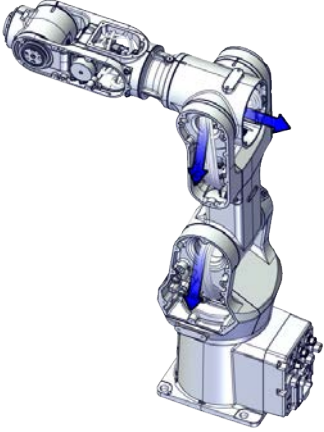
	Action	Note
3	Pull out the upper cable harness from the robot in the direction shown in the figure.	 xx1800003015

Refitting the upper cable package



Use these procedures to refit the upper cable package.

Refitting the upper cable harness through the axis-4 gearbox

	Action	Note
1	For robots with protection type Clean Room: Clean the joints that have been opened and wipe the parts free from particles with spirit on a lint free.	

Continues on next page

5.3.1 Replacing the upper cable package
Continued

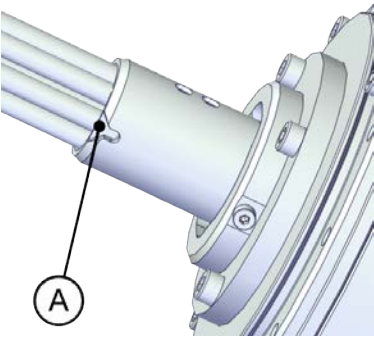
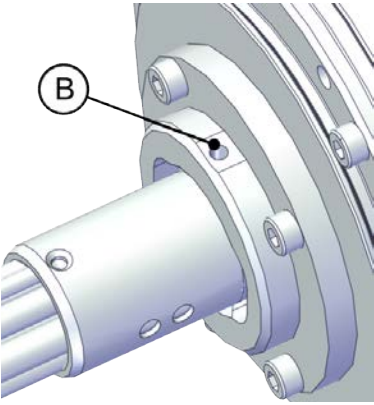
	Action	Note
2	<p>Insert the cable package in the housing and through the axis-4 gearbox.</p> <p> Tip</p> <p>Wrap the connectors with the masking tape.</p> <p> CAUTION</p> <p>Make sure that no cables or hoses are twisted or strained. Reroute if necessary.</p>	<p>Cable protection tube orientation: use the notch (A) on the cable protection tube as a reference when inserting the cable package, which should be at the opposite direction to the locking screw hole (B) on the gearbox.</p>  <p>xx1800003017</p>  <p>xx1800003601</p>

Securing the upper cable package to the axis-4 gearbox

	Action	Note
1	<p>For robots with protection type Clean Room: Clean the joints that have been opened and wipe the parts free from particles with spirit on a lint free.</p>	

Continues on next page

5 Repair

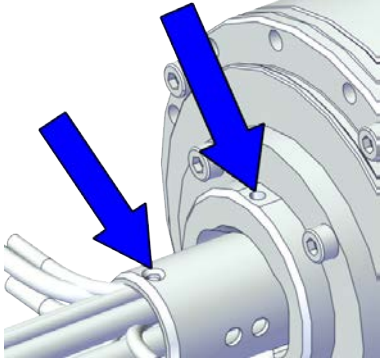
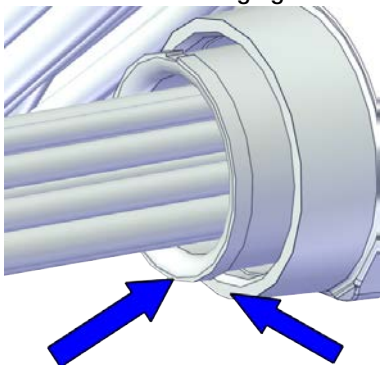
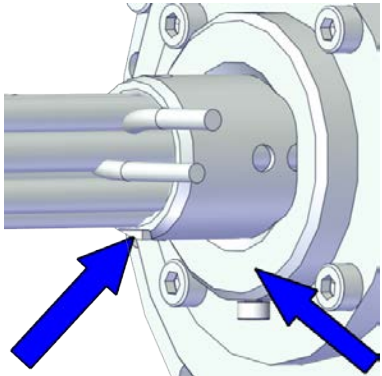

5.3.1 Replacing the upper cable package

Continued

	Action	Note
2	<p>Make sure that:</p> <ul style="list-style-type: none">• The hole on the cable protection tube is aligned with the locking screw hole on the gearbox.• The cable protection tube surface is completely parallel with the pulley cover at one side and with the flange at the other side.	<p>Holes to be aligned are shown in the following figure.</p>  <p>xx1800003018</p> <p>Surfaces to be paralleled are shown in the following figures.</p>  <p>xx1800003019</p>  <p>xx1800003020</p>

Continues on next page

5.3.1 Replacing the upper cable package
Continued

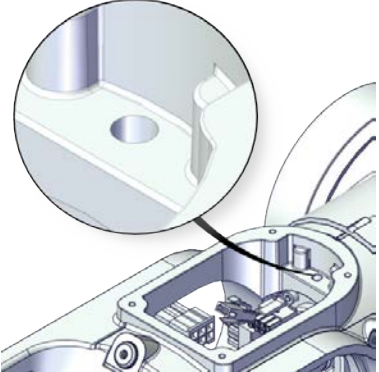
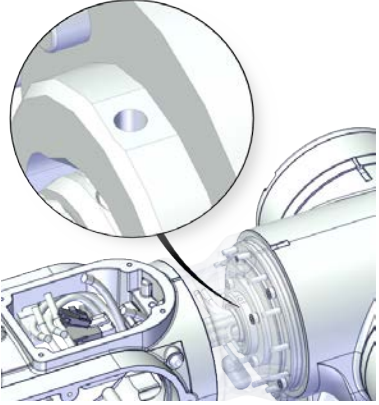
	Action	Note
3	<p>Apply a little Loctite 243 to the locking screw and refit the locking screw.</p> <p> Note</p> <p>Make sure the locking screw header is parallel with flange surface.</p> <p> Note</p> <p>If there is locking liquid residues on the screw or screw hole, please clean it before refitting. Remove residual locking liquid after refitting.</p>	<p>Screw: M3x8 (1 pcs) Tightening torque: 0.4 Nm Valid for IRB 1100-4/0.475</p>  <p>xx1800003031</p>  <p>xx1800003001</p>

Continues on next page



5 Repair

5.3.1 Replacing the upper cable package

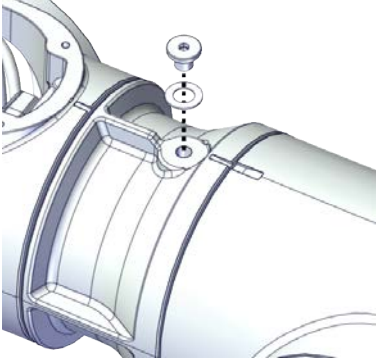
Continued

	Action	Note
4	Refit the plug screw and washer on the extender unit.	<p>Plug screw: 3HAC064146-001 For robots with protection type Clean Room (option 3351-4) Plug screw, Clean Room: 3HAC070309-001 For robots with protection class IP67 (option 3350-670) For robots with protection type Clean Room (option 3351-4) Rubber sealing washer on extender unit: 3HAC067995-001 Tightening torque: 2 Nm</p>  <p>xx1800003000</p>

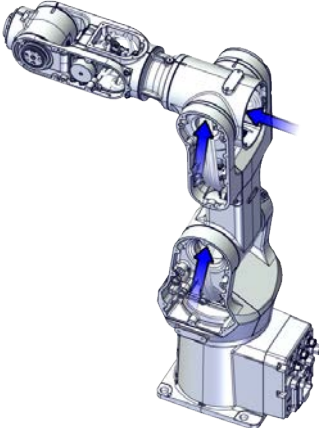

Guiding the upper cable package down to the swing

	Action	Note
1	For robots with protection type Clean Room: Clean the joints that have been opened and wipe the parts free from particles with spirit on a lint free.	
2	<p>Guide the upper cable package to go through from the housing, through the lower arm, down to the swing.</p> <p>When inserting the cable package, leave the axis-4 motor connectors in the housing and the axis-3 motor connectors in the lower arm.</p> <p> Tip Wrap the connectors with the masking tape.</p> <p> Tip It is possible to remove the lower arm support and swing support for easy routing of the cable package. Remember to refit the lower arm support and swing support after the cable package is inserted to place.</p>	 <p>xx1800003016</p>

Continues on next page

5.3.1 Replacing the upper cable package
Continued

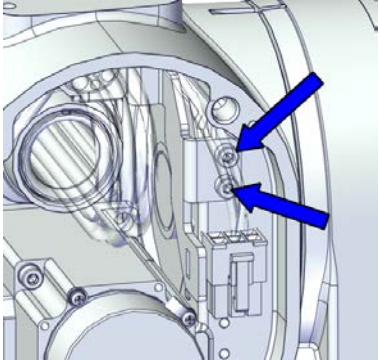
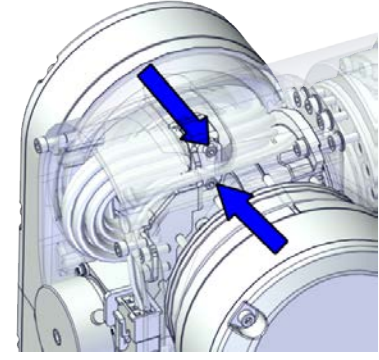
Securing the upper cable package to the housing

	Action	Note
1	For robots with protection type Clean Room: Clean the joints that have been opened and wipe the parts free from particles with spirit on a lint free.	
2	Refit the cable bracket.	<p>Screw: M3x8 12.9 Lafre 2C2B/FC6.9 (2 pcs) Tightening torque: 0.8 Nm</p>  <p>xx1800003013</p> <p>Screw: M2.5x6 12.9 Lafre 2C2B/FC6.9 (2 pcs) Tightening torque: 0.6 Nm</p>  <p>xx1800003014</p>
3	<p>Route and secure the cabling with cable straps.</p> <p> CAUTION</p> <p>Correct cable routing is highly important. If the cables are routed and secured incorrectly the cables can be damaged.</p>	

Reconnecting the axis-4 motor connectors



	Action	Note
1	For robots with protection type Clean Room: Clean the joints that have been opened and wipe the parts free from particles with spirit on a lint free.	

Continues on next page

5 Repair

5.3.1 Replacing the upper cable package

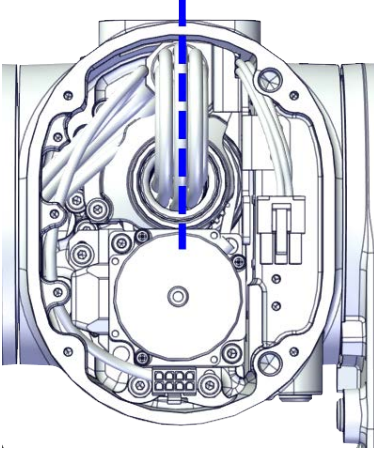
Continued

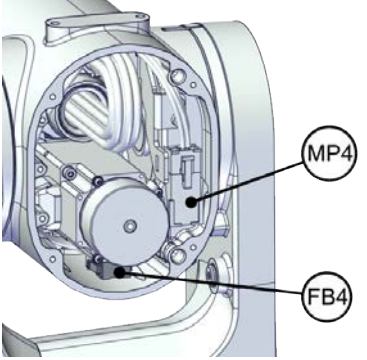

	Action	Note
2	<p>Check the cabling status. Make sure the cabling is in vertical state and is not twisted.</p>	 <p>xx1800003618</p>
3	<p>Reconnect the connectors.</p> <ul style="list-style-type: none"> • FB4 • MP4 <p> Tip</p> <p>See the number markings on the connectors for help to find the corresponding connector.</p>	 <p>xx1800003012</p>

Refitting the axis-3 motor

	Action	Note
1	<p>For robots with protection type Clean Room: Clean the joints that have been opened and wipe the parts free from particles with spirit on a lint free.</p>	
2	<p>Check that:</p> <ul style="list-style-type: none"> • all assembly surfaces are clean and without damages • the motor is clean and undamaged. 	

Continues on next page

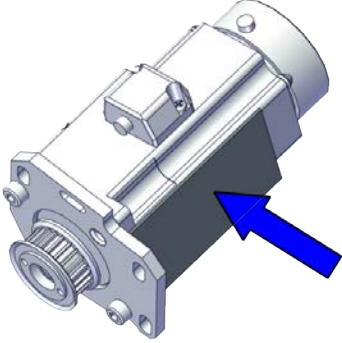
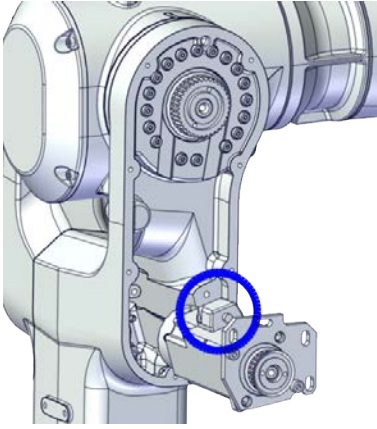
5.3.1 Replacing the upper cable package
Continued

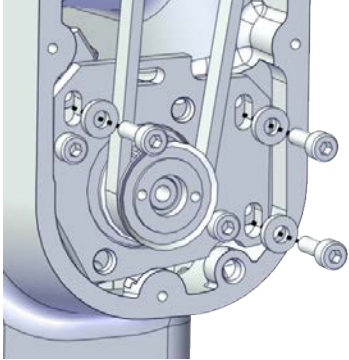

	Action	Note
3	<p>Check the cooling pad. Replace if damaged.</p>	<p>Cooling pad for axis-3 and -4 motors: 3HAC071021-001</p>  <p>xx1800003604</p>
4	<p>Orient the motor correctly and fit it into the lower arm.</p>	<p>Motor orientation: orient the motor according to the figure below, in regard to the encircled motor connector.</p>  <p>xx1800003021</p>
5	<p>Refit the screws and washers.</p> <p> Note Do not tighten the screws yet.</p>	<p>Screw: M4x12 12.9 Lafre 2C2B/FC6.9 (3 pcs) Washer, 3HAC063985-001 (3 pcs)</p>  <p>xx1800003009</p>

Continues on next page

5 Repair

5.3.1 Replacing the upper cable package

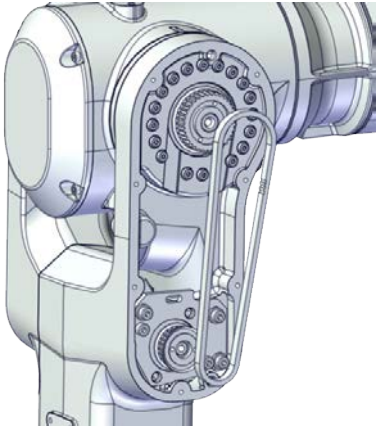
Continued

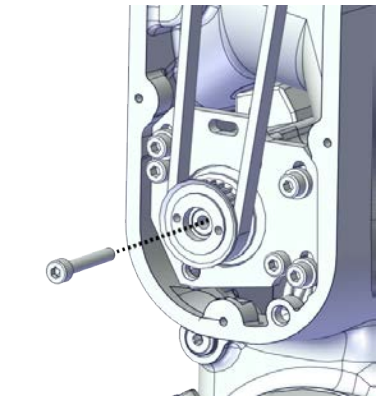
	Action	Note
6	Install the timing belt to the pulleys and verify that the belt runs correctly in the grooves of the pulleys.	 <p>xx1800003022</p>
7	Install an M4x25 or longer adjustment screw to the motor.  Note Do not insert the entire screw to the hole.	 <p>xx1900000009</p>

Continues on next page

5.3.1 Replacing the upper cable package
Continued

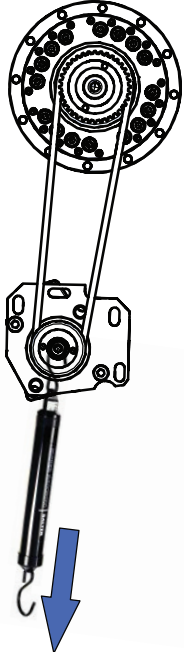
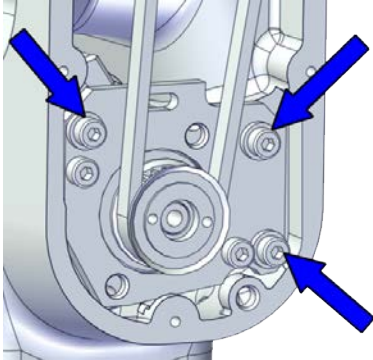
	Action	Note
8	Use a handheld dynamometer hooking to the screw and pull the dynamometer to reach the initial referenced force.	<p>Initial referenced force for used belt: 21.7-23.94 N (for reference only) Initial referenced force for new belt: 31-34.2 N</p>  <p>xx1900000028</p>
9	Secure the motor with the screws.	<p>Tightening torque: 3 Nm</p>  <p>xx1800003008</p>
10	Use a sonic tension meter to measure the timing belt tension.	<p>Used belt: 102-109 Hz New belt: 113-143 Hz (for reference only)</p>
11	If the timing belt tension does not meet the requirement, loosen the motor screws and readjust.	

Continues on next page



5 Repair

5.3.1 Replacing the upper cable package

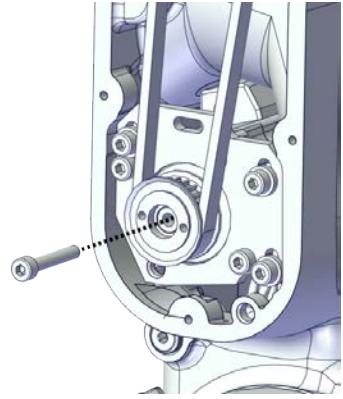
Continued

	Action	Note
12	Remove the adjustment screw from the motor.	 <p>xx190000009</p>

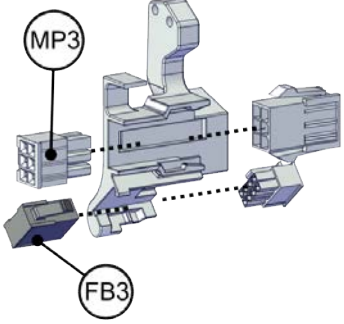
Reconnecting the axis-3 motor connectors

	Action	Note
1	For robots with protection type Clean Room: Clean the joints that have been opened and wipe the parts free from particles with spirit on a lint free.	
2	Slide the connectors into the connector plate and reconnect the connectors. <ul style="list-style-type: none"> • FB3 • MP3  Tip See the number markings on the connectors for help to find the corresponding connector.	 <p>xx1800003005</p>
3	Route and secure the cabling with cable straps.  CAUTION Correct cable routing is highly important. If the cables are routed and secured incorrectly the cables can be damaged.	

Continues on next page

5.3.1 Replacing the upper cable package
Continued

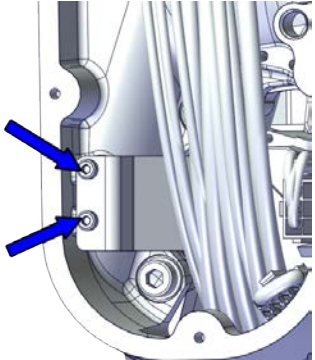
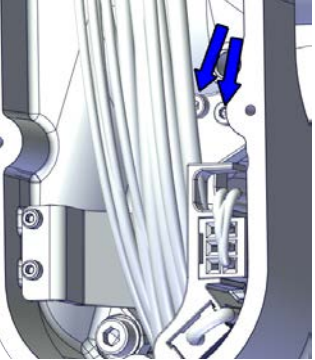
	Action	Note
4	Refit the cable bracket.	<p>Screw: M2.5x6 12.9 Lafre 2C2B/FC6.9 (2 pcs) Tightening torque: 0.6 Nm</p>  <p>xx1800003006</p>
5	Refit the connector plate.	<p>Screw: M3x12 12.9 Lafre 2C2B/FC6.9 (2 pcs) Tightening torque: 0.4 Nm</p>  <p>xx1800003004</p>

Securing the upper cable package to the axis-2 gearbox

	Action	Note
1	For robots with protection type Clean Room: Clean the joints that have been opened and wipe the parts free from particles with spirit on a lint free.	

Continues on next page

5 Repair

5.3.1 Replacing the upper cable package

Continued

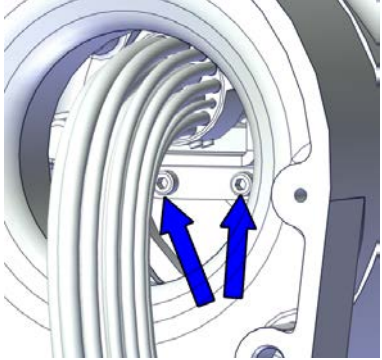

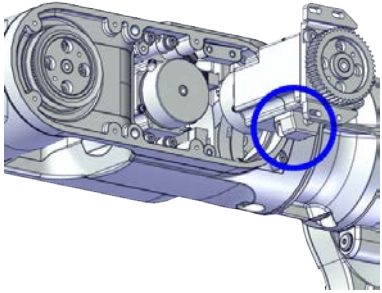

	Action	Note
2	Refit the cable bracket.	<p>Screw: M2.5x6 12.9 Lafre 2C2B/FC6.9 (2 pcs) Tightening torque: 0.6 Nm</p>  <p>xx1800003002</p>

Refitting the axis-6 motor

	Action	Note
1	For robots with protection type Clean Room: Clean the joints that have been opened and wipe the parts free from particles with spirit on a lint free.	
2	Check that: <ul style="list-style-type: none"> all assembly surfaces are clean and without damages the motor is clean and undamaged. 	
3	<p>Orient the motor correctly and fit it into the lower arm.</p> <p> Tip</p> <p>Leave the connectors FB5 and FB6 accessible from the process hub and the connectors MP5 and MP6 accessible from wrist side.</p>	<p>Motor orientation: orient the motor according to the figure below, in regard to the encircled motor connector.</p>  <p>xx1800003023</p>

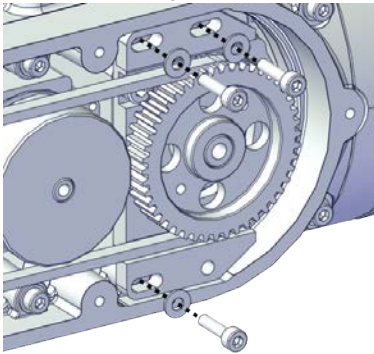
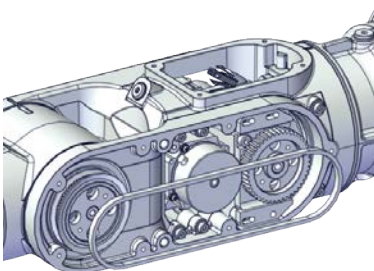
Continues on next page

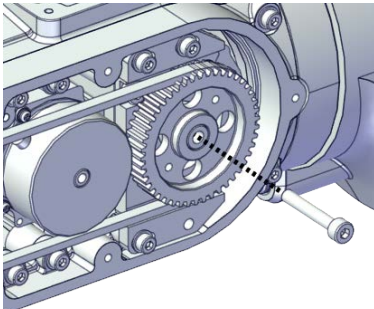
5.3.1 Replacing the upper cable package
Continued

	Action	Note
4	Refit the screws and washers.  Note Do not tighten the screws yet.	Screw: M3x12 12.9 Lafre 2C2B/FC6.9 (3 pcs)  xx1800002996
5	Install the timing belt to the pulleys and verify that the belt runs correctly in the grooves of the pulleys.	 xx1800003024
6	Install an M4x25 or longer adjustment screw to the motor.  Note Do not insert the entire screw to the hole.	 xx1900000007
7	Use a handheld dynamometer hooking to the screw and pull the dynamometer to reach the initial referenced force.	Initial referenced force for used belt: 8.96-9.8 N (for reference only) Initial referenced force for new belt: 12.8-14  xx1900000026

Continues on next page

5 Repair

5.3.1 Replacing the upper cable package

Continued

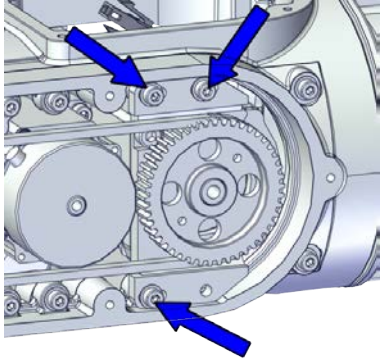
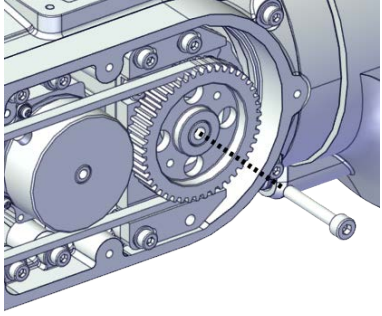
	Action	Note
8	Secure the motor with the screws.	<p>Tightening torque: 1.4 Nm</p>  <p>xx1800002995</p>
9	Use a sonic tension meter to measure the timing belt tension.	<p>Used belt: 81.3-86.9 Hz New belt: 90-114 Hz (for reference only)</p>
10	If the timing belt tension does not meet the requirement, loosen the motor screws and readjust.	
11	Remove the adjustment screw from the motor.	 <p>xx1900000007</p>

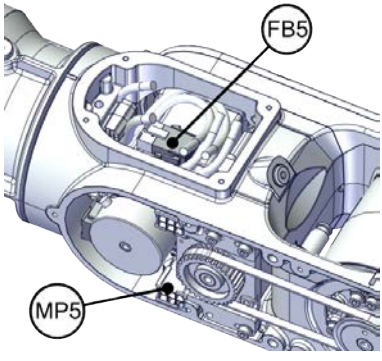

Reconnecting the axis-5 motor connectors

	Action	Note
1	For robots with protection type Clean Room: Clean the joints that have been opened and wipe the parts free from particles with spirit on a lint free.	
2	<p>Reconnect the connectors.</p> <ul style="list-style-type: none"> • FB5 • MP5 <p> Tip</p> <p>See the number markings on the connectors for help to find the corresponding connector.</p>	 <p>xx1800003025</p>

Continues on next page

	Action	Note
3	Route and secure the cabling with cable straps.  CAUTION Correct cable routing is highly important. If the cables are routed and secured incorrectly the cables can be damaged.	
4	Insert the cabling and connectors into the wrist.	

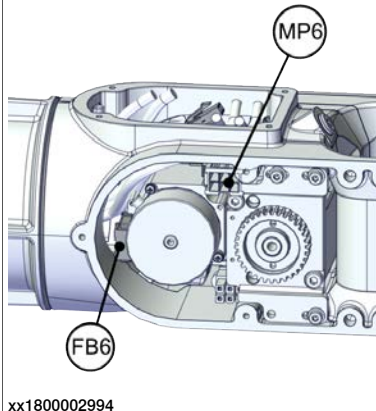
Reconnecting the axis-6 motor connectors

	Action	Note
1	For robots with protection type Clean Room: Clean the joints that have been opened and wipe the parts free from particles with spirit on a lint free.	
2	Reconnect the connectors. <ul style="list-style-type: none"> • FB6 • MP6  Tip See the number markings on the connectors for help to find the corresponding connector.	
3	Route and secure the cabling with cable straps.  CAUTION Correct cable routing is highly important. If the cables are routed and secured incorrectly the cables can be damaged.	
4	Insert the cabling and connectors into the wrist.	

Refitting the process hub



	Action	Note
1	For robots with protection type Clean Room: Clean the joints that have been opened and wipe the parts free from particles with spirit on a lint free.	

Continues on next page

5 Repair

5.3.1 Replacing the upper cable package

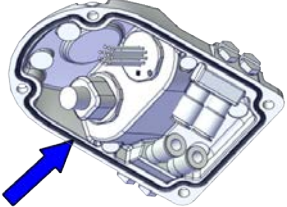
Continued

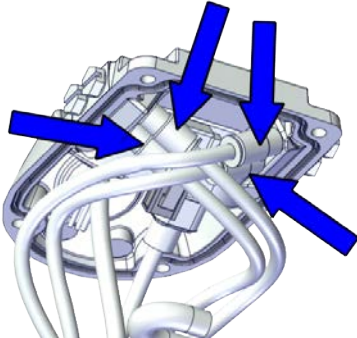
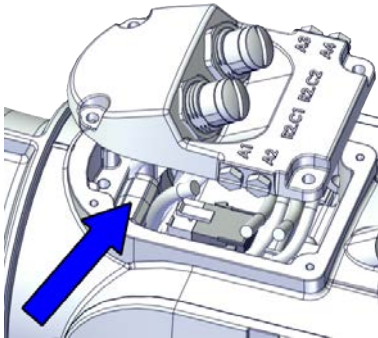
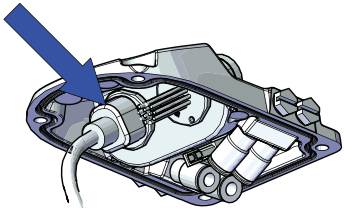
	Action	Note
2	<p>For robots with protection class IP67 (option 3350-670) For robots with protection type Clean Room (option 3351-4) Check the gasket. Replace if damaged.</p>	<p>Gasket for process hub: 3HAC065352-001</p>  <p>xx1900002187</p>
3	<p>Reconnect the air hoses in a cross pattern.</p> <p> Tip</p> <p>See the number markings on the air hoses for help to find the corresponding air hoses. The air hoses with the same number connect to the same Y-shaped connector.</p>	 <p>xx1800002945</p>
4	<p>For robots with CP/CS cabling Reconnect the connector.</p> <ul style="list-style-type: none"> J5.C1 	 <p>xx1800002947</p>
5	<p>For robots with Ethernet cabling Reconnect the connector J5.C2 using the tool.</p>	<p>J5.C2 connector assembly tool, included in the special toolkit 3HAC071022-001</p>  <p>xx1800002948</p>

Continues on next page

5.3.1 Replacing the upper cable package
Continued

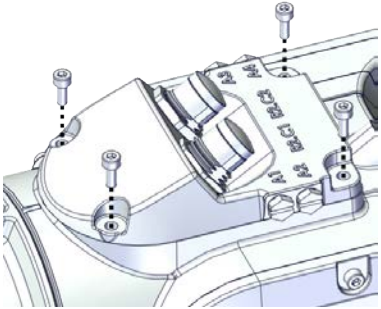
	Action	Note
6	Route and secure the cabling with cable straps.  CAUTION Correct cable routing is highly important. If the cables are routed and secured incorrectly the cables can be damaged.	
7	Refit the cover.	Screw: M3x8 12.9 Lafre 2C2B/FC6.9 (4 pcs) Tightening torque: 1.2 Nm  xx1800002944

Reconnecting the air hoses, CP/CS cabling and Ethernet cabling (if equipped)

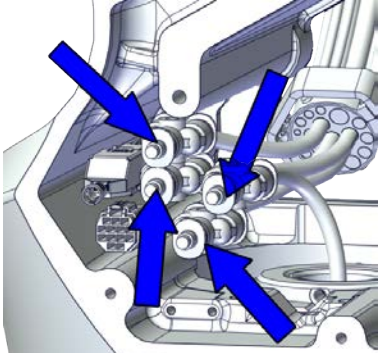
	Action	Note
1	For robots with protection type Clean Room: Clean the joints that have been opened and wipe the parts free from particles with spirit on a lint free.	
2	Reconnect the air hoses in a cross pattern to the Y-shaped connectors.  Tip See the number markings on the air hoses for help to find the corresponding air hoses. The air hoses with the same number connect to the same Y-shaped connector.	 xx1800002500

Continues on next page

5 Repair

5.3.1 Replacing the upper cable package

Continued

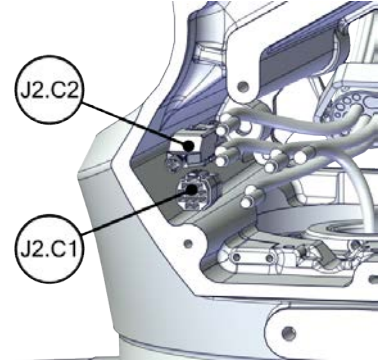
	Action	Note
3	<p>Reconnect the connectors.</p> <ul style="list-style-type: none"> • J2.C1 • J2.C2 <p> Tip</p> <p>See the number markings on the connectors for help to find the corresponding connector.</p>	 <p>xx1800002501</p>

Securing the cable package to the swing

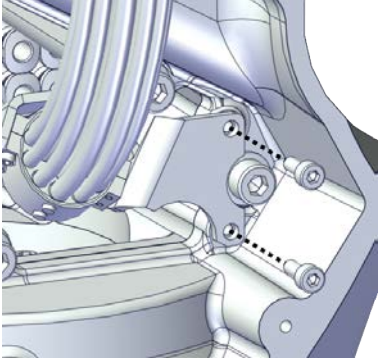

	Action	Note
1	<p>For robots with protection type Clean Room: Clean the joints that have been opened and wipe the parts free from particles with spirit on a lint free.</p>	
2	<p>Refit the cable bracket.</p>	<p>Screw: M3x8 12.9 Lafre 2C2B/FC6.9 (2 pcs) Tightening torque: 0.8 Nm</p>  <p>xx1800002499</p>

Refitting the axis-2 motor

	Action	Note
1	<p>For robots with protection type Clean Room: Clean the joints that have been opened and wipe the parts free from particles with spirit on a lint free.</p>	
2	<p>Check that:</p> <ul style="list-style-type: none"> • all assembly surfaces are clean and without damages • the motor is clean and undamaged. 	

Continues on next page

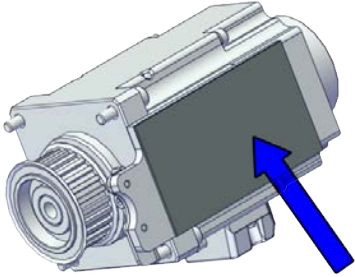
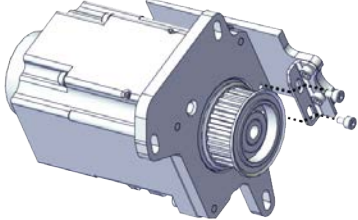
5.3.1 Replacing the upper cable package
Continued

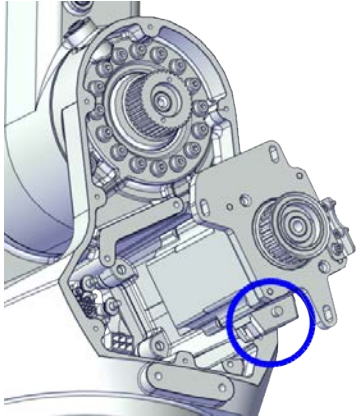

	Action	Note
3	<p>Check the cooling pad. Replace if damaged, as shown in the following step.</p>	<p>Cooling pad for axis-1 and -2 motors: 3HAC071020-001</p>  <p>xx1800003603</p>
4	<p>Remove the screws. Replace with a new cooling pad and then refit the screws.</p>	<p>Screw: M3x5 12.9 Lafre 2C2B/FC6.9 (2 pcs) Tightening torque: 1.2 Nm</p>  <p>xx1800003026</p>
5	<p>Orient the motor correctly and fit it into the swing.</p>  <p>Tip</p> <p>Bend the motor signal cable back towards the swing support.</p>	<p>Motor orientation: orient the motor according to the figure below, in regard to the encircled motor connector.</p>  <p>xx1800003027</p>

Continues on next page

5 Repair

5.3.1 Replacing the upper cable package

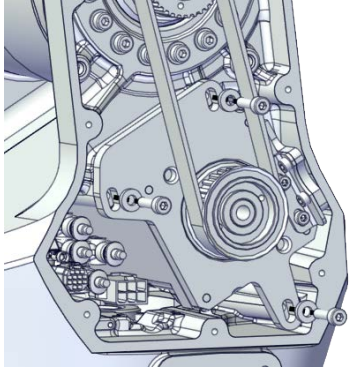
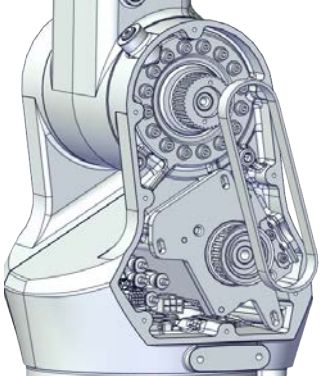
Continued

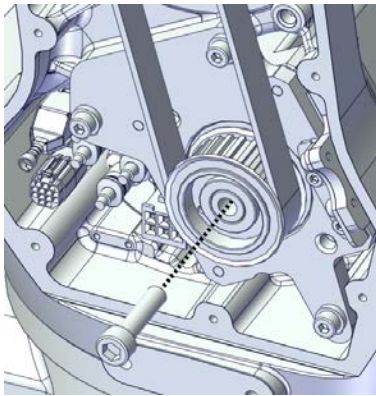
	Action	Note
6	<p>Refit the screws and washers.</p> <p> Note</p> <p>Do not tighten the screws yet.</p>	<p>Screw: M4x16 12.9 Lafre 2C2B/FC6.9 (3 pcs) Washer, 3HAC063985-001 (3 pcs)</p>  <p>xx1800002494</p>
7	<p>Install the timing belt to the pulleys and verify that the belt runs correctly in the grooves of the pulleys.</p>	 <p>xx1800003028</p>
8	<p>Install an M6x25 or longer adjustment screw to the motor.</p> <p> Note</p> <p>Do not insert the entire screw to the hole.</p>	 <p>xx1900000010</p>

Continues on next page

5.3.1 Replacing the upper cable package
Continued

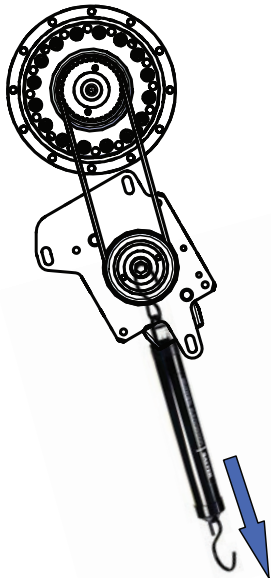
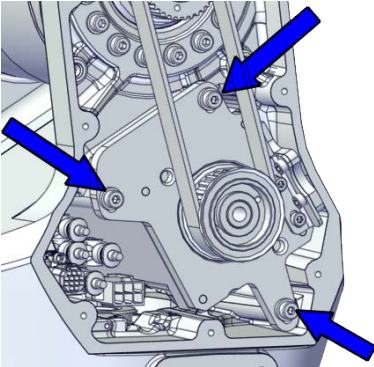

	Action	Note
9	Use a handheld dynamometer hooking to the screw and pull the dynamometer to reach the initial referenced force.	<p>Initial referenced force for used belt: 68.18-75.04 N (for reference only) Initial referenced force for new belt: 97.4-107.2 N</p>  <p>xx1900000029</p>
10	Secure the motor with the screws.	<p>Tightening torque: 3.5 Nm</p>  <p>xx1800002493</p>
11	Use a sonic tension meter to measure the timing belt tension.	<p>Used belt: 163-174 Hz New belt: 180-229 Hz (for reference only)</p>
12	If the timing belt tension does not meet the requirement, loosen the motor screws and readjust.	

Continues on next page

5 Repair

5.3.1 Replacing the upper cable package

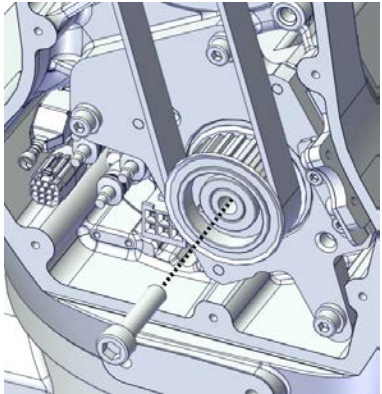
Continued

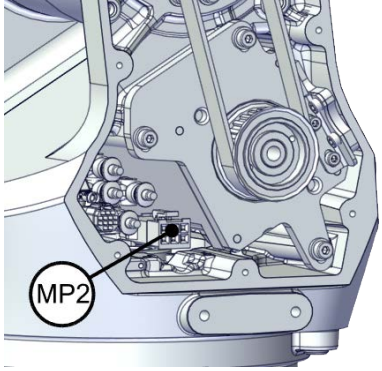

	Action	Note
13	Remove the adjustment screw from the motor.	 <p>xx1900000010</p>
14	Reconnect the connector. <ul style="list-style-type: none"> • MP2  Tip See the number markings on the connectors for help to find the corresponding connector.	 <p>xx1800002495</p>

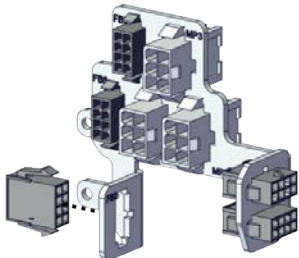
Reconnecting the connectors at the division point

	Action	Note
1	For robots with protection type Clean Room: Clean the joints that have been opened and wipe the parts free from particles with spirit on a lint free.	
2	Insert the female header of the connectors to the connector plate.	 <p>xx1800003029</p>

Continues on next page

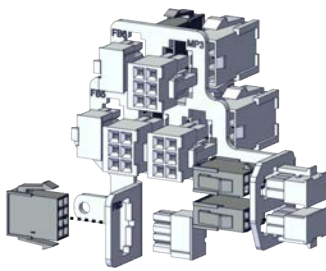
5.3.1 Replacing the upper cable package
Continued

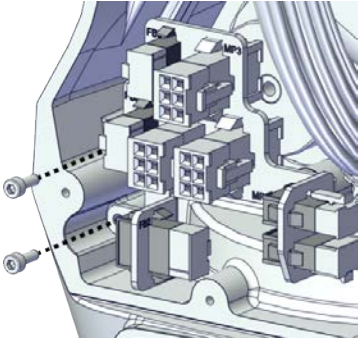
	Action	Note
3	<p>Reconnect the connectors.</p> <ul style="list-style-type: none"> • J2.FB2,3,4,5,6 • J2.MP3,4,5/6 <p> Tip</p> <p>See the number markings on the connectors for help to find the corresponding connector.</p>	 <p>xx1800003030</p>
4	<p>Route and secure the cabling with cable straps.</p> <p> CAUTION</p> <p>Correct cable routing is highly important. If the cables are routed and secured incorrectly the cables can be damaged.</p>	
5	<p>Refit the connector plate.</p>	<p>Screw: M3x8 12.9 Lafre 2C2B/FC6.9 (2 pcs) Tightening torque: 0.8 Nm</p>  <p>xx1800002489</p>

Refitting the covers

	Action	Note
1	<p>For robots with protection type Clean Room: Clean the joints that have been opened and wipe the parts free from particles with spirit on a lint free.</p>	

Continues on next page

5 Repair

5.3.1 Replacing the upper cable package

Continued

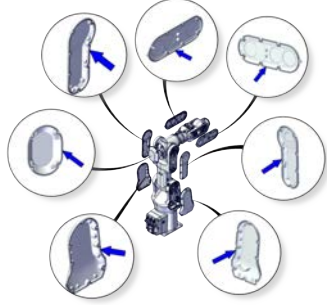
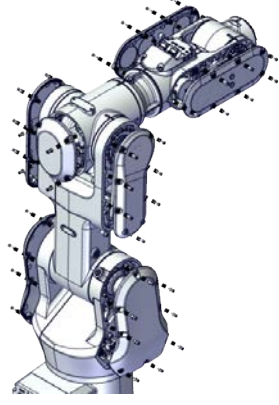
	Action	Note
2	<p>For robots with protection class IP67 (option 3350-670)</p> <p>For robots with protection type Clean Room (option 3351-4)</p> <p>Check the gaskets.</p> <p>Replace if damaged.</p>	 <p>xx1900002174</p>
3	Apply grease to the cable package, cover all moving area of the package.	
4	Apply grease to the covers that have contacting area with the cable package.	
5	<p>Refit the covers.</p> <ul style="list-style-type: none"> • Wrist covers • Housing cover • Lower arm cover • Lower arm support cover • Swing cover • Swing support cover 	<p>Screw: M3x8 12.9 Lafre 2C2B/FC6.9</p> <p>Tightening torque: 1.2 Nm</p>  <p>xx1800003606</p>

Concluding procedure

	Action	Note
1	<p>For robots with protection type Clean Room:</p> <p>Clean and paint the joints that have been opened. See Cut the paint or surface on the robot before replacing parts on page 124.</p> <p> Note</p> <p>After all repair work, wipe the Clean Room robot free from particles with spirit on a lint free cloth.</p>	
2	Recalibrate the robot.	Calibration is detailed in section Calibration on page 685 .

Continues on next page

	Action	Note
3	 DANGER Make sure all safety requirements are met when performing the first test run. See Test run after installation, maintenance, or repair on page 91 .	

5 Repair

5.3.2 Replacing the lower cable package

5.3.2 Replacing the lower cable package

Location of the lower cable package

The lower cable package is located as shown in the figure.

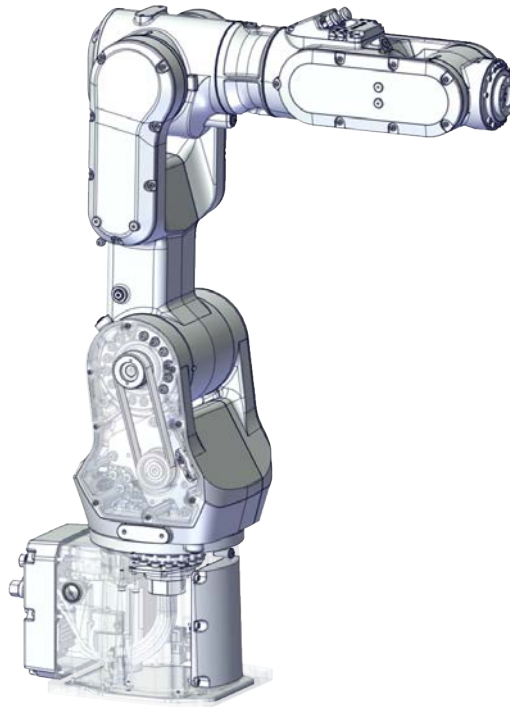

xx1800002465

Required spare parts



Note

The spare part numbers that are listed in the table can be out of date. See the latest spare parts of the IRB 1100 via myABB Business Portal, www.abb.com/myABB.

Spare part	Article number	Note
Lower cable harness, basic	3HAC075521-001	Used with protection classes IP40 and IP67.
Lower cable harness, basic, Clean Room	3HAC075514-001	Used with protection type Clean Room.
Lower cable harness (CP/CS and air hose, without Ethernet)	3HAC075522-001	Used with protection classes IP40 and IP67.
Lower cable harness, Clean Room (CP/CS and air hose, without Ethernet)	3HAC075515-001	Used with protection type Clean Room.
Lower cable harness (CP/CS and air hose, with Ethernet)	3HAC075523-001	Used with protection classes IP40 and IP67.
Lower cable harness, Clean Room (CP/CS and air hose, with Ethernet)	3HAC075581-001	Used with protection type Clean Room.

Continues on next page

5.3.2 Replacing the lower cable package
Continued

Spare part	Article number	Note
Motor with flange, axis 2	3HAC083588-001	.
Timing belt, axis 2	3HAC061935-001	
Base bottom cover	3HAC060463-001	Standard configuration, used for robots with rear connector interface.
Base rear cover	3HAC070312-001	Used for robots with bottom connector interface.
Base rear cover, Clean Room	3HAC075513-001	Used for robots with bottom connector interface. Used with protection type Clean Room.
Base adapter	3HAC070313-001	Used for robots with bottom connector interface.
Base adapter, Clean Room	3HAC075793-001	Used for robots with bottom connector interface. Used with protection type Clean Room.
Swing cover	3HAC069051-001	
Swing cover, Clean Room	3HAC075498-001	Used with protection type Clean Room.
Swing support cover	3HAC069052-001	
Swing support cover, Clean Room	3HAC075500-001	Used with protection type Clean Room.
SMB cover	3HAC069060-001	
SMB cover, Clean Room	3HAC075506-001	Used with protection type Clean Room.
Gasket for base bottom	3HAC065345-001	Used with protection class IP67 and protection type Clean Room. Replace if damaged.
Gasket for base rear	3HAC065350-001	Used with protection class IP67 and protection type Clean Room. Replace if damaged.
Gasket for swing cover	3HAC061959-003	Used with protection class IP67 and protection type Clean Room. Replace if damaged.
Gasket for swing support cover	3HAC065317-001	Used with protection class IP67 and protection type Clean Room. Replace if damaged.
Gasket for SMB cover	3HAC065344-001	Used with protection class IP67 and protection type Clean Room. Replace if damaged.
Cooling pad for axis-1 and -2 motors	3HAC071020-001	Cooling pads are wear parts. One cooling pad sheet contains 6 pieces of small pad. Replace if damaged with one piece each time.
Washer	3HAC063985-001	9x4.3x1, Steel

Continues on next page

5 Repair

5.3.2 Replacing the lower cable package

Continued

Required tools and equipment

Equipment	Article number	Note
Standard toolkit	-	Content is defined in section Standard toolkit on page 733 .
Calibration tool box, Axis Calibration	3HAC074119-001	Delivered as a set of calibration tools. Required if Axis Calibration is the valid calibration method for the robot. The tool box also includes a unique calibration pin for IRB 1100 to be fitted to the tool flange during calibration of axis 6.
24 VDC power supply	-	Used to release the motor brakes.
Sonic tension meter	-	Used for measuring the timing belt tension.
Dynamometer	-	Used for measuring the timing belt tension.
brake release button assembly tool	-	Included in the special toolkit 3HAC071022-001. Used to remove and refit the brake release button.

Required consumables

Consumable	Article number	Note
Cable straps	-	
Grease	3HAC029132-001	FM 222
Locking liquid	-	Loctite 2400 (or equivalent Loctite 243)

Deciding calibration routine

Decide which calibration routine to be used, based on the information in the table. Depending on which routine is chosen, action might be required prior to beginning the repair work of the robot, see the table.

	Action	Note
1	Decide which calibration routine to use for calibrating the robot. <ul style="list-style-type: none">Reference calibration. External cable packages (DressPack) and tools can stay fitted on the robot.Fine calibration. All external cable packages (DressPack) and tools must be removed from the robot.	 Note Calibrating axis 6 always requires tools to be removed from the mounting flange (also for reference calibration) since the mounting flange is used for installation of the calibration tool.

Continues on next page



5.3.2 Replacing the lower cable package
Continued

Action	Note
<p>If the robot is to be calibrated with reference calibration: Find previous reference values for the axis or create new reference values. These values are to be used after the repair procedure is completed, for calibration of the robot.</p> <p>If no previous reference values exist, and no new reference values can be created, then reference calibration is not possible.</p>	<p>Follow the instructions given in the reference calibration routine on the FlexPendant to create reference values.</p> <p>Creating new values requires possibility to move the robot.</p> <p>Read more about reference calibration for Axis Calibration in Reference calibration routine on page 696.</p>
<p>If the robot is to be calibrated with fine calibration: Remove all external cable packages (DressPack) and tools from the robot.</p>	

Removing the lower cable package

Use these procedures to remove the lower cable package.

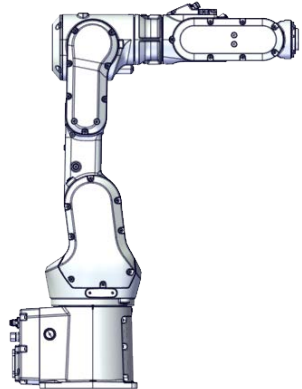
Preparations before removing the lower cable package

	Action	Note
1	Decide which calibration routine to use, and take actions accordingly prior to beginning the repair procedure.	
2	Jog all axes to zero position.	 <p>xx1800003288</p>
3	 DANGER Turn off all: <ul style="list-style-type: none"> • electric power supply • hydraulic pressure supply • air pressure supply to the robot, before entering the safeguarded space.	

Continues on next page



5 Repair

5.3.2 Replacing the lower cable package



Continued

	Action	Note
4	 CAUTION For robots with protection type Clean Room Always cut the paint with a knife and grind the paint edge when disassembling parts of the robot! See Cut the paint or surface on the robot before replacing parts on page 124.	

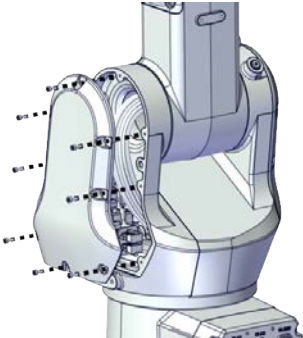
Removing the axis-2 motor

	Action	Note
1	 DANGER Make sure that all supplies for electrical power, hydraulic pressure, and air pressure are turned off.	
2	 CAUTION For robots with protection type Clean Room Always cut the paint with a knife and grind the paint edge when disassembling parts of the robot! See Cut the paint or surface on the robot before replacing parts on page 124.	
3	 CAUTION Removing motors will release axes. This means the axes can fall down. Make sure axes are well supported before removing motors.	
4	Remove the swing support cover.	 xx1800002488

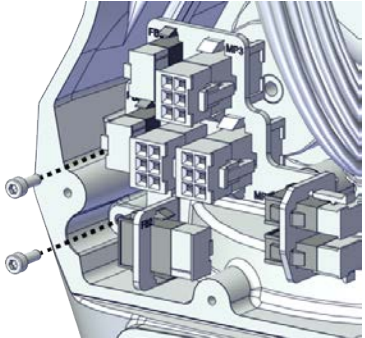
Continues on next page

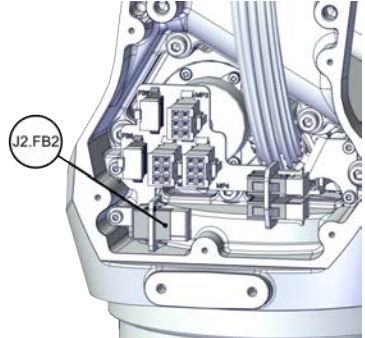
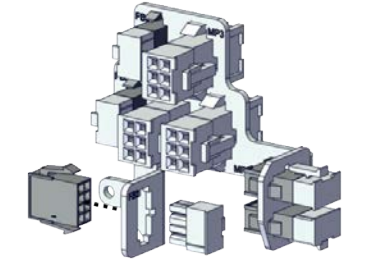
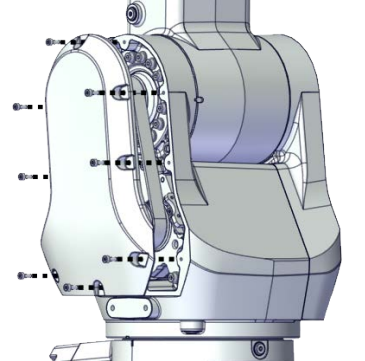

	Action	Note
5	<p>Remove the connector plate.</p> <p> CAUTION</p> <p>Be aware of the cabling that are attached to the connector plate! The connector plate cannot be removed completely until the connectors are removed from the plate.</p>	 <p>xx1800002489</p>
6	<p>Disconnect the connector.</p> <ul style="list-style-type: none"> J2.FB2 <p> Tip</p> <p>Take photos of the connector and cable position before disconnecting them, to have as a reference when reconnecting.</p>	 <p>xx1800002490</p>
7	<p>Snap loose and remove the female head of the connector from the connector plate.</p>	 <p>xx1800002491</p>
8	<p>Remove the swing cover.</p>	 <p>xx1800002492</p>

Continues on next page

5 Repair

5.3.2 Replacing the lower cable package

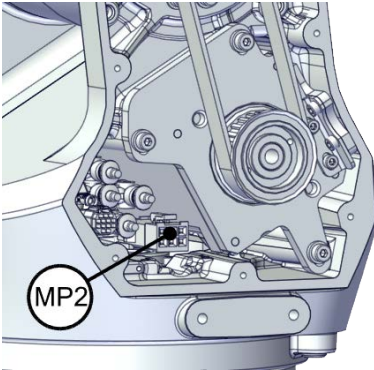
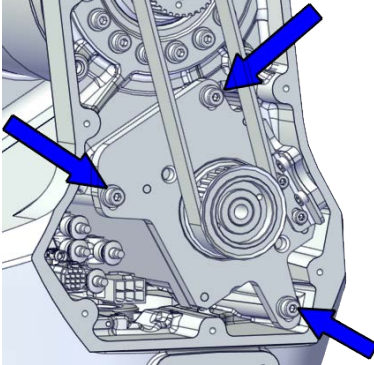
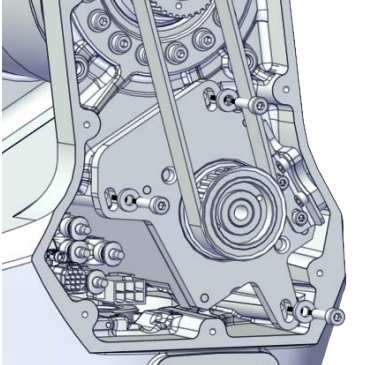
Continued

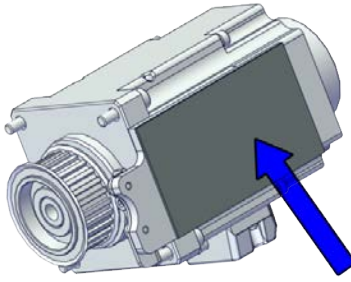

	Action	Note
9	<p>Disconnect the connector.</p> <ul style="list-style-type: none"> MP2 <p> Tip</p> <p>Take photos of the connector and cable position before disconnecting them, to have as a reference when reconnecting.</p>	 <p>xx1800002495</p>
10	<p>Loosen the screws and move the motor slightly to slacken the timing belt.</p>	 <p>xx1800002493</p>
11	<p>Remove the screws and washers.</p>	 <p>xx1800002494</p>
12	<p>Carefully lift out the motor.</p> <p> CAUTION</p> <p>A cooling pad is attached to the motor, which may stick to the casting. Always use a plastic sheet with caution to remove the pad from the casting. Pay attention not to scratch the casting or damage the pad.</p> <p> CAUTION</p> <p>Be aware of the motor cabling. The motor cannot be removed completely until the connector is disconnected, as shown in following step.</p>	<p>Cooling pad location</p>  <p>xx1800003603</p>

Continues on next page

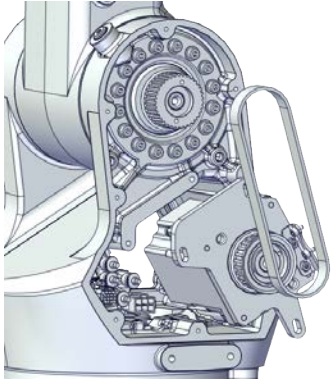
5.3.2 Replacing the lower cable package
Continued

	Action	Note
13	Remove the timing belt from its groove on the motor.	 <p>xx1800002496</p>

Loosening the cable package from axis-1 gearbox

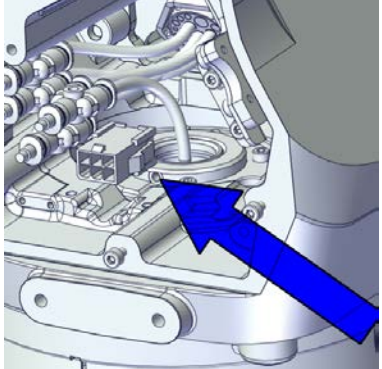
	Action	Note
1	 DANGER Make sure that all supplies for electrical power, hydraulic pressure, and air pressure are turned off.	
2	 CAUTION For robots with protection type Clean Room Always cut the paint with a knife and grind the paint edge when disassembling parts of the robot! See Cut the paint or surface on the robot before replacing parts on page 124 .	
3	Access the cable package locking screw on the axis-1 gearbox from the swing and then loosen the locking screw.	 <p>xx1800003032</p>
4	Remove the locking screw.	



Continues on next page

5 Repair

5.3.2 Replacing the lower cable package

Continued

Disconnecting the connectors at the division point

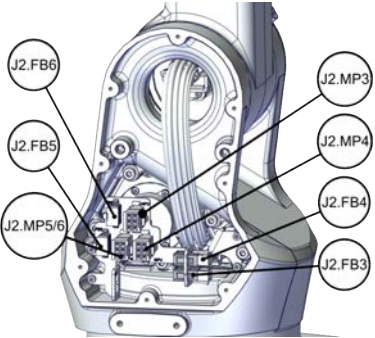
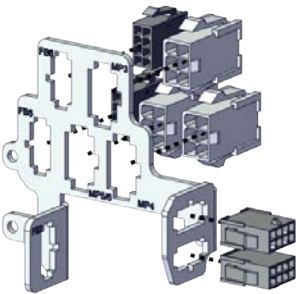
	Action	Note
1	 DANGER Make sure that all supplies for electrical power, hydraulic pressure, and air pressure are turned off.	
2	 CAUTION For robots with protection type Clean Room Always cut the paint with a knife and grind the paint edge when disassembling parts of the robot! See Cut the paint or surface on the robot before replacing parts on page 124 .	
3	Disconnect the connectors. <ul style="list-style-type: none"> • J2.FB3,4,5,6 • J2.MP3,4,5/6  Tip Take photos of the connector and cable position before disconnecting them, to have as a reference when reconnecting.	 xx1800002497
4	Snap loose and remove the female head of the connectors from the connector plate.	 xx1800002498

Separating the cable package from the swing



	Action	Note
1	 DANGER Make sure that all supplies for electrical power, hydraulic pressure, and air pressure are turned off.	

Continues on next page

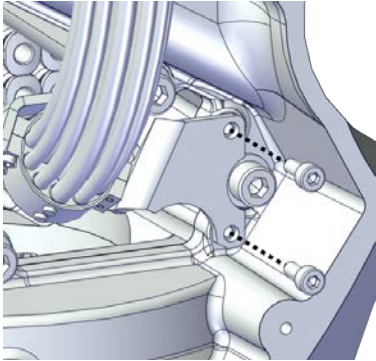
5.3.2 Replacing the lower cable package
Continued

	Action	Note
2	<p> CAUTION</p> <p>For robots with protection type Clean Room Always cut the paint with a knife and grind the paint edge when disassembling parts of the robot! See <i>Cut the paint or surface on the robot before replacing parts on page 124.</i></p>	
3	Remove the cable bracket.	 <p>xx1800002499</p>

Disconnecting the air hoses, CP/CS cabling and Ethernet cabling (if equipped)

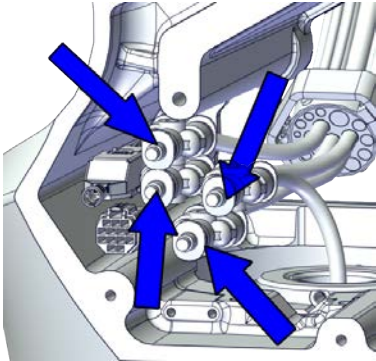

	Action	Note
1	<p> DANGER</p> <p>Make sure that all supplies for electrical power, hydraulic pressure, and air pressure are turned off.</p>	
2	<p> CAUTION</p> <p>For robots with protection type Clean Room Always cut the paint with a knife and grind the paint edge when disassembling parts of the robot! See <i>Cut the paint or surface on the robot before replacing parts on page 124.</i></p>	
3	Disconnect the air hoses from the Y-shaped connectors.	 <p>xx1800002500</p>

Continues on next page



5 Repair

5.3.2 Replacing the lower cable package

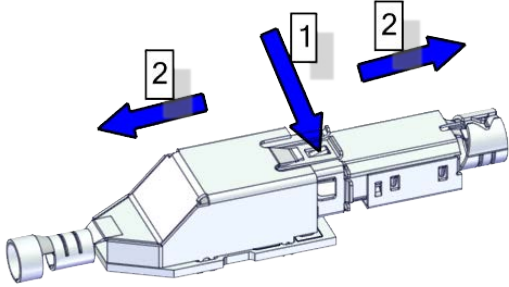
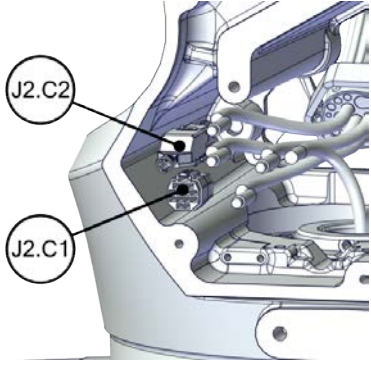
Continued





	Action	Note
4	<p>Disconnect the connectors.</p> <ul style="list-style-type: none"> • J2.C1 • J2.C2 <p> Tip</p> <p>Take photos of the connector and cable position before disconnecting them, to have as a reference when reconnecting.</p> <p> Tip</p> <p>The connector clip has to be pressed (1) and pushed forward (2) to separate the J2.C2 (for Ethernet cabling).</p>  <p>xx1800002943</p>	 <p>xx1800002501</p>

Disconnecting the SMB connectors

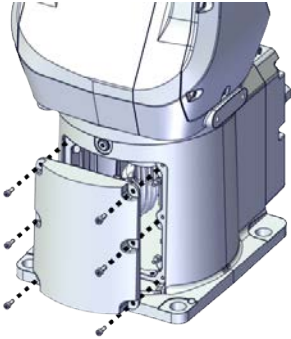

	Action	Note
1	<p> DANGER</p> <p>Make sure that all supplies for electrical power, hydraulic pressure, and air pressure are turned off.</p>	
2	<p> ELECTROSTATIC DISCHARGE (ESD)</p> <p>The unit is sensitive to ESD. Before handling the unit read the safety information in section The unit is sensitive to ESD on page 49.</p>	
3	<p> CAUTION</p> <p>For robots with protection type Clean Room</p> <p>Always cut the paint with a knife and grind the paint edge when disassembling parts of the robot! See Cut the paint or surface on the robot before replacing parts on page 124.</p>	

Continues on next page

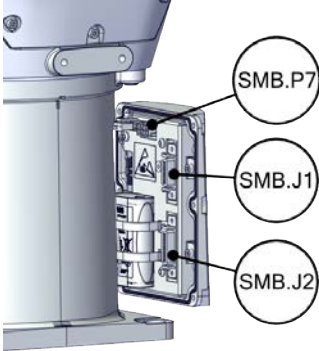
5.3.2 Replacing the lower cable package Continued

	Action	Note
4	<p>Remove the SMB cover attachment screws and carefully open the cover.</p> <p> CAUTION</p> <p>Clean cover from metal residues before opening. Metal residues can cause shortage on the boards which can result in hazardous failures.</p> <p> CAUTION</p> <p>There are cabling attached to the cover. The cover cannot be removed completely until the connectors are removed.</p>	 <p>xx1800002467</p>
5	<p>Disconnect the connectors.</p> <ul style="list-style-type: none"> • SMB.P7 • SMB.J1 • SMB.J2 <p> Tip</p> <p>Take photos of the connector and cable position before disconnecting them, to have as a reference when reconnecting.</p>	 <p>xx1800002468</p>
6	Remove the SMB cover completely from the base.	

Putting the robot on its side

	Action	Note
1	<p> DANGER</p> <p>Make sure that all supplies for electrical power, hydraulic pressure, and air pressure are turned off.</p>	
2	<p> CAUTION</p> <p>For robots with protection type Clean Room</p> <p>Always cut the paint with a knife and grind the paint edge when disassembling parts of the robot! See Cut the paint or surface on the robot before replacing parts on page 124.</p>	
3	<p> CAUTION</p> <p>The IRB 1100 robot weighs 21.1 kg and can be lifted by one person.</p>	

Continues on next page



5 Repair

5.3.2 Replacing the lower cable package

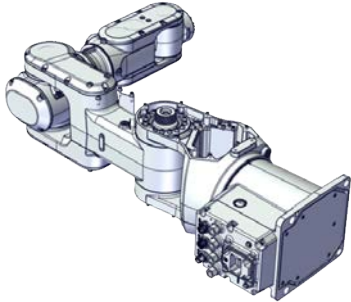
Continued

	Action	Note
4	 WARNING The robot is likely to be mechanically unstable if not secured to the foundation.	
5	Loosen the robot from the foundation by removing the foundation attachment screws and put the robot on its side.	 xx1800003033

Opening the connector interface plate

	Action	Note
1	 DANGER Make sure that all supplies for electrical power, hydraulic pressure, and air pressure are turned off.	
2	 CAUTION For robots with protection type Clean Room Always cut the paint with a knife and grind the paint edge when disassembling parts of the robot! See <i>Cut the paint or surface on the robot before replacing parts on page 124.</i>	

Continues on next page

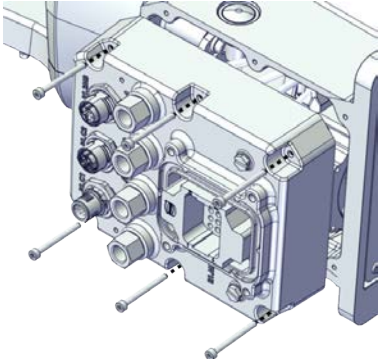
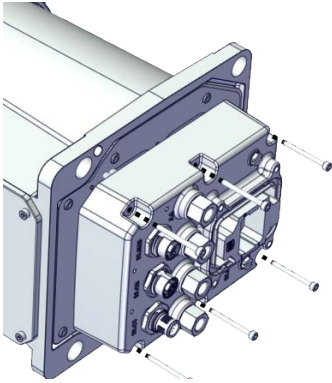
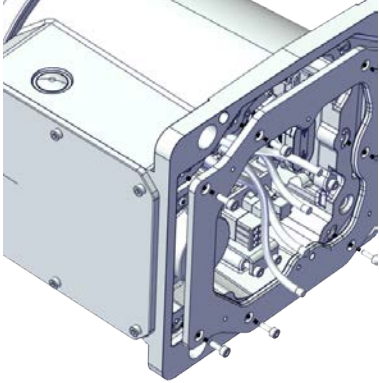
	Action	Note
3	<p>Remove the connector interface plate attachment screws and carefully open the plate.</p> <p> CAUTION</p> <p>There are cabling attached to the cover. The cover cannot be removed completely until the connectors are removed.</p>	<p>Valid for cabling with rear interface</p>  <p>xx1800003034</p> <p>Valid for cabling with bottom interface (option 3309-1)</p>  <p>xx1800003055</p>
4	<p>Valid for cabling with bottom interface (option 3309-1)</p> <p>Remove the base adapter.</p>	 <p>xx1800003056</p>

Continues on next page



5 Repair

5.3.2 Replacing the lower cable package

Continued

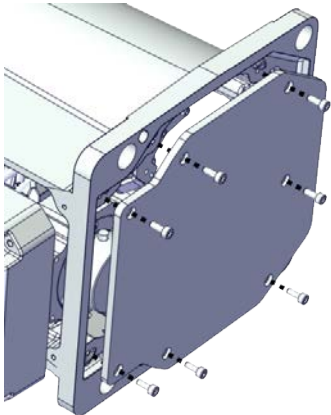
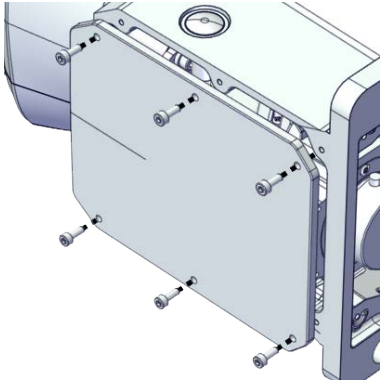

Removing the brake release button

Notice that the procedure differs depending on if the connector interface is located either at the rear or at the bottom of the base.

	Action	Note
1	 DANGER Make sure that all supplies for electrical power, hydraulic pressure, and air pressure are turned off.	
2	 CAUTION For robots with protection type Clean Room Always cut the paint with a knife and grind the paint edge when disassembling parts of the robot! See Cut the paint or surface on the robot before replacing parts on page 124 .	
3	Valid for cabling with rear interface Remove the base bottom cover.	 xx1800003035
4	Valid for cabling with bottom interface (option 3309-1) Remove the base rear cover.	 xx1800003057

Continues on next page

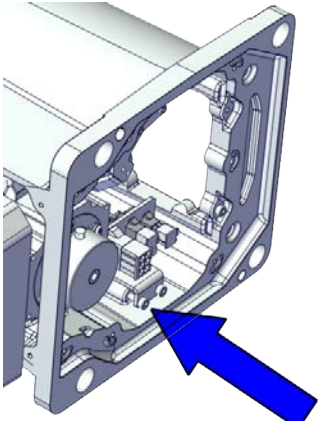
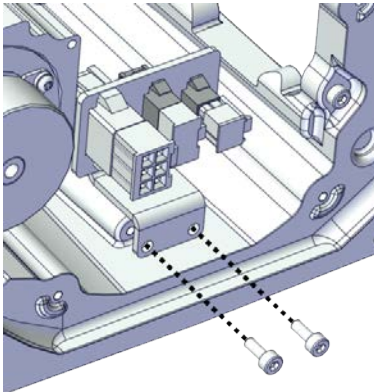
5.3.2 Replacing the lower cable package
Continued

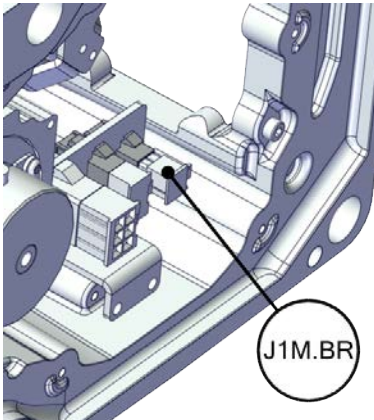
	Action	Note
5	Disconnect the earth cable.	 <p>xx1800003036</p>
6	Remove the connector plate.	 <p>xx1800003037</p>
7	Disconnect the connector. <ul style="list-style-type: none"> • J1M.BR  Tip Take photos of the connector and cable position before disconnecting them, to have as a reference when reconnecting.	 <p>xx1800003038</p>

Continues on next page



5 Repair

5.3.2 Replacing the lower cable package

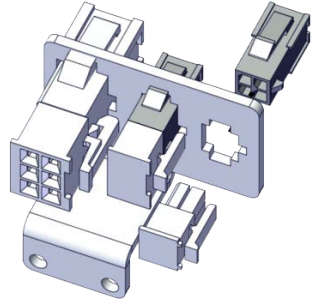
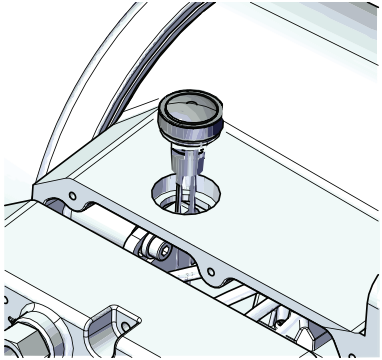
Continued

	Action	Note
8	Remove the female header of the J1M.BR connector from the connector plate.	 <p>xx1800003039</p>
9	Remove the brake release button from the base using the tool.	<p>brake release button assembly tool, included in the special toolkit 3HAC071022-001</p>  <p>xx1800003040</p>

Disconnecting axis-1 motor connectors



	Action	Note
1	 <p>DANGER</p> <p>Make sure that all supplies for electrical power, hydraulic pressure, and air pressure are turned off.</p>	
2	 <p>CAUTION</p> <p>For robots with protection type Clean Room Always cut the paint with a knife and grind the paint edge when disassembling parts of the robot! See Cut the paint or surface on the robot before replacing parts on page 124.</p>	

Continues on next page

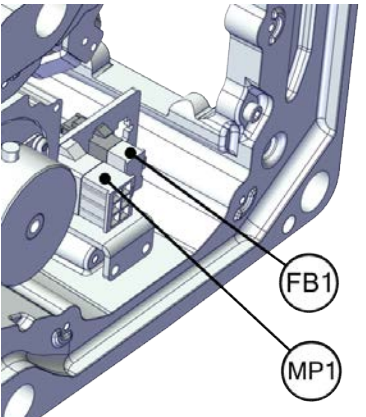
5.3.2 Replacing the lower cable package
Continued

	Action	Note
3	<p>Disconnect the connectors.</p> <ul style="list-style-type: none"> • FB1 • MP1 <p> Tip</p> <p>Take photos of the connector and cable position before disconnecting them, to have as a reference when reconnecting.</p>	 <p>xx1800003041</p>

Separating the cable package from the base

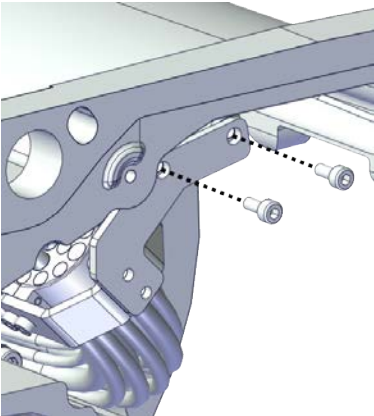
	Action	Note
1	<p> DANGER</p> <p>Make sure that all supplies for electrical power, hydraulic pressure, and air pressure are turned off.</p>	
2	<p> CAUTION</p> <p>For robots with protection type Clean Room</p> <p>Always cut the paint with a knife and grind the paint edge when disassembling parts of the robot! See Cut the paint or surface on the robot before replacing parts on page 124.</p>	
3	<p>Remove the cable bracket.</p>	 <p>xx1800003042</p>



Continues on next page

5 Repair



5.3.2 Replacing the lower cable package

Continued

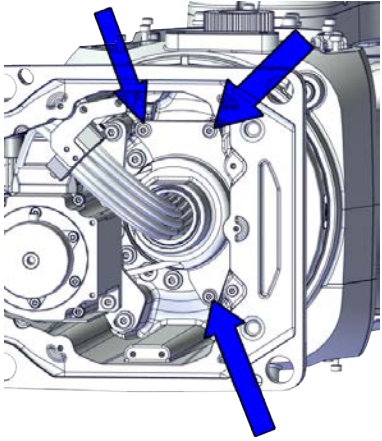
Separating the cable package from the axis-1 gearbox

	Action	Note
1	 DANGER Make sure that all supplies for electrical power, hydraulic pressure, and air pressure are turned off.	
2	 CAUTION For robots with protection type Clean Room Always cut the paint with a knife and grind the paint edge when disassembling parts of the robot! See Cut the paint or surface on the robot before replacing parts on page 124 .	
3	Remove the pulley cover.	 xx1800003043

Pulling out the cable package

	Action	Note
1	 DANGER Make sure that all supplies for electrical power, hydraulic pressure, and air pressure are turned off.	
2	 CAUTION For robots with protection type Clean Room Always cut the paint with a knife and grind the paint edge when disassembling parts of the robot! See Cut the paint or surface on the robot before replacing parts on page 124 .	

Continues on next page

5.3.2 Replacing the lower cable package
Continued

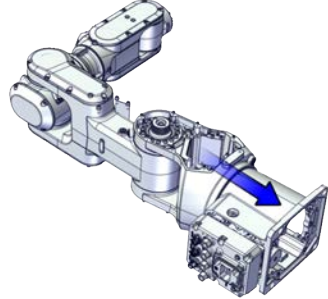
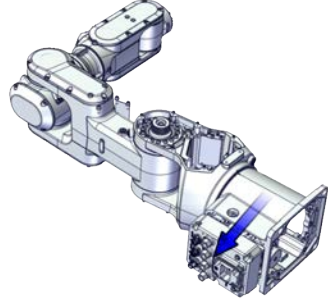
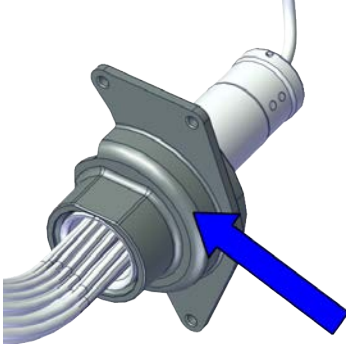
	Action	Note
3	Pull out the lower cable package from the axis-1 gearbox.	 <p>xx1800003044</p>
4	Pull out the lower cable package from the base.	 <p>xx1800003045</p>
5	Remove the pulley cover from the lower cable package.	 <p>xx1800003046</p>

Refitting the lower cable package

Use these procedures to refit the lower cable package.

Refitting the brake release button

	Action	Note
1	For robots with protection type Clean Room: Clean the joints that have been opened and wipe the parts free from particles with spirit on a lint free.	

Continues on next page

5 Repair

5.3.2 Replacing the lower cable package

Continued

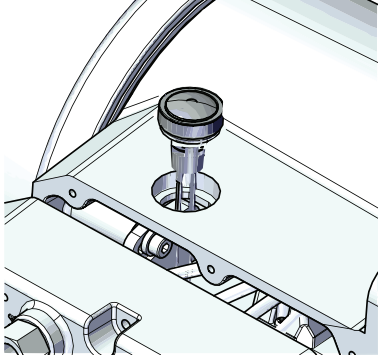
	Action	Note
2	Refit the brake release button.  Note Do not reconnect the connector yet. Do not tighten the button yet.	brake release button assembly tool, included in the special toolkit 3HAC071022-001  xx1800003040



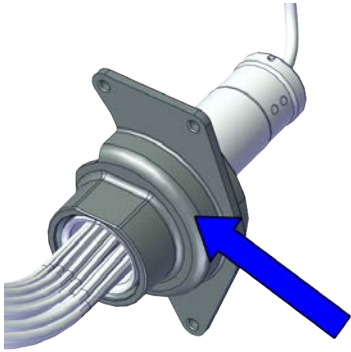

Refitting the lower cable package through the axis-1 gearbox

Notice that the procedure differs depending on if the connector interface is located either at the rear or at the bottom of the base.

	Action	Note
1	For robots with protection type Clean Room: Clean the joints that have been opened and wipe the parts free from particles with spirit on a lint free.	
2	Refit the pulley cover to the lower cable package.	 xx1800003046

Continues on next page

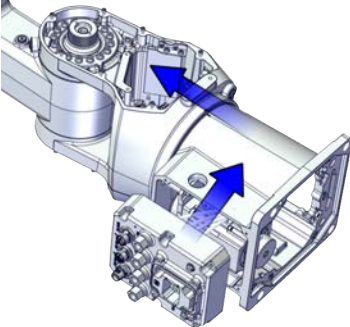
5.3.2 Replacing the lower cable package
Continued





	Action	Note
3	<p>Valid for cabling with rear interface Insert the cable package in the base and up through the axis-1 gearbox, through the rear.</p> <p> Tip Wrap the connectors with the masking tape.</p> <p> CAUTION Make sure that no cables or hoses are twisted or strained. Reroute if necessary.</p>	 <p>xx1800003047</p> <p>Cable protection tube orientation: use the encircled notch on the cable protection tube as a reference when inserting the cable package, which should be at the opposite direction to the locking screw hole on the gearbox.</p>  <p>xx1800003048</p>

Continues on next page

5 Repair

5.3.2 Replacing the lower cable package

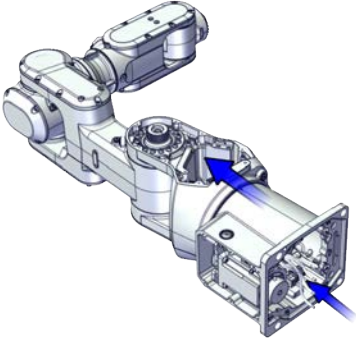
Continued

	Action	Note
4	<p>Valid for cabling with bottom interface (option 3309-1)</p> <p>Insert the cable package in the base and up through the axis-1 gearbox, through the bottom.</p> <p> Tip</p> <p>Wrap the connectors with the masking tape.</p> <p> CAUTION</p> <p>Make sure that no cables or hoses are twisted or strained. Reroute if necessary.</p>	 <p>xx1800003060</p> <p>Cable protection tube orientation: use the encircled notch on the cable protection tube as a reference when inserting the cable package, which should be at the opposite direction to the locking screw hole on the gearbox.</p>  <p>xx1800003048</p>

Securing the lower cable package to the axis-1 gearbox

	Action	Note
1	<p>For robots with protection type Clean Room: Clean the joints that have been opened and wipe the parts free from particles with spirit on a lint free.</p>	

Continues on next page

5.3.2 Replacing the lower cable package
Continued

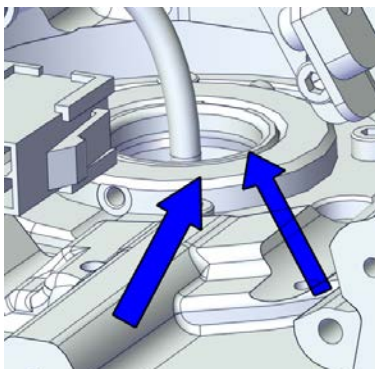
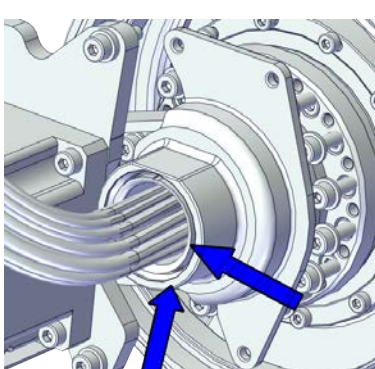

	Action	Note
2	<p>Make sure that:</p> <ul style="list-style-type: none">• The hole on the cable protection tube is aligned with the locking screw hole on the gearbox.• The cable protection tube surface is completely parallel with the pulley cover at one side and with the flange at the other side.	 <p>xx1800003063</p>  <p>xx1800003049</p>  <p>xx1800003050</p>

Continues on next page

5 Repair

5.3.2 Replacing the lower cable package

Continued

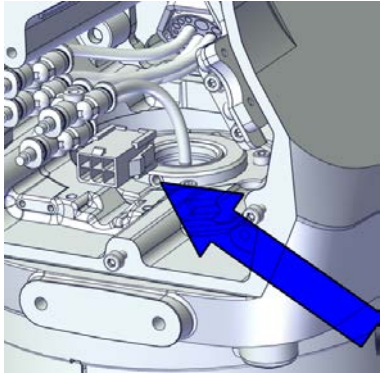
	Action	Note
3	<p>Apply a little Loctite 243 to the locking screw and refit the locking screw.</p> <p> Note</p> <p>Make sure the locking screw header is parallel with flange surface.</p> <p> Note</p> <p>If there is locking liquid residues on the screw or screw hole, please clean it before refitting. Remove residual locking liquid after refitting.</p>	<p>Screw: M3x8 (1 pcs) Tightening torque: 0.4 Nm</p>  <p>xx1800003032</p>

Refitting the pulley cover

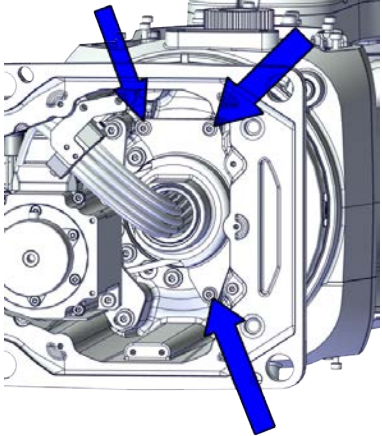
	Action	Note
1	<p>For robots with protection type Clean Room: Clean the joints that have been opened and wipe the parts free from particles with spirit on a lint free.</p>	
2	<p>Refit the puller cover.</p>	<p>Screw: M3x8 12.9 Lafre 2C2B/FC6.9 (3 pcs) Tightening torque: 1.2 Nm</p>  <p>xx1800003043</p>



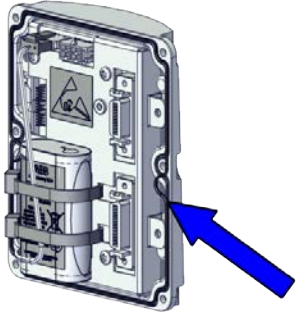

Checking the SMB cover gasket

	Action	Note
1	<p>For robots with protection type Clean Room: Clean the joints that have been opened and wipe the parts free from particles with spirit on a lint free.</p>	

Continues on next page

	Action	Note
2	<p>For robots with protection class IP67 (option 3350-670) For robots with protection type Clean Room (option 3351-4) Check the gasket. Replace if damaged.</p>	 <p>xx1900002186</p>

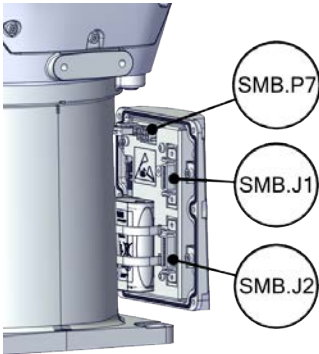
Reconnecting the SMB connectors

	Action	Note
1	 <p>ELECTROSTATIC DISCHARGE (ESD)</p> <p>The unit is sensitive to ESD. Before handling the unit read the safety information in section The unit is sensitive to ESD on page 49.</p>	
2	<p>For robots with protection type Clean Room Clean the joints that have been opened and wipe the parts free from particles with spirit on a lint free.</p>	
3	<p>Reconnect the connectors.</p> <ul style="list-style-type: none"> • SMB.P7 • SMB.J1 • SMB.J2  <p>Tip</p> <p>See the number markings on the connectors for help to find the corresponding connector.</p>	<p>Tightening torque: 0.3 Nm</p>  <p>xx1800002468</p>
4	<p>Route and secure the cabling with cable straps.</p>  <p>CAUTION</p> <p>Correct cable routing is highly important. If the cables are routed and secured incorrectly the cables can be damaged.</p>	

Continues on next page

5 Repair

5.3.2 Replacing the lower cable package

Continued

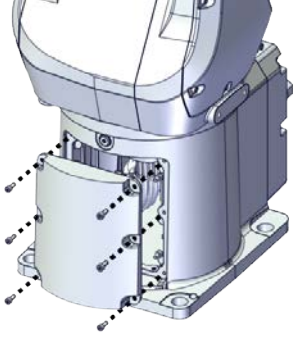

	Action	Note
5	Refit the SMB cover to the base.	<p>Screw: M3x8 12.9 Lafre 2C2B/FC6.9 (6 pcs) Tightening torque: 1.2 Nm</p>  <p>xx1800002467</p>

Refitting the connector interface plate

	Action	Note
1	For robots with protection type Clean Room: Clean the joints that have been opened and wipe the parts free from particles with spirit on a lint free.	

Continues on next page

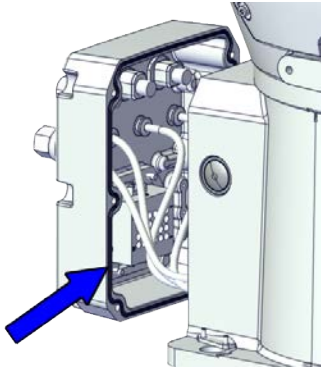
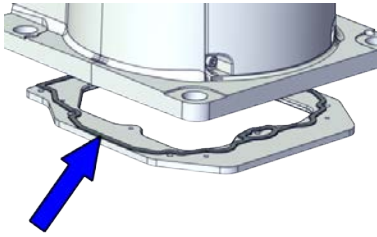
5.3.2 Replacing the lower cable package
Continued

	Action	Note
2	<p>For robots with protection class IP67 (option 3350-670) For robots with protection type Clean Room (option 3351-4) Check the gasket. Replace if damaged.</p>	<p>Valid for cabling with rear interface Gasket for base rear: 3HAC065350-001</p>  <p>xx1900002183</p> <p>Valid for cabling with bottom interface (option 3309-1) Gasket for base bottom: 3HAC065345-001</p>  <p>xx1900002188</p>
3	<p>Route and secure the cabling with cable straps.</p> <p> CAUTION</p> <p>Correct cable routing is highly important. If the cables are routed and secured incorrectly the cables can be damaged.</p>	

Continues on next page

5 Repair

5.3.2 Replacing the lower cable package

Continued

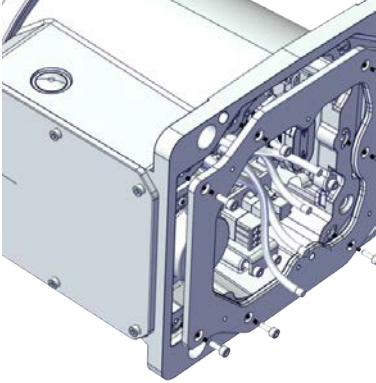
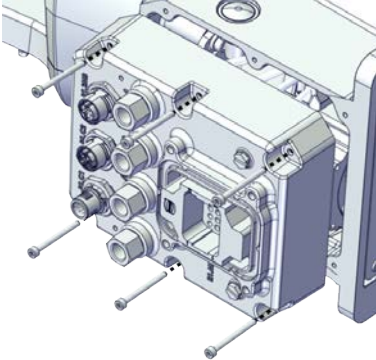
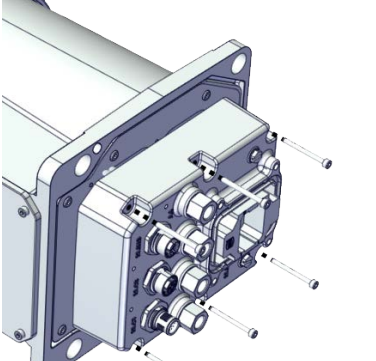
	Action	Note
4	<p>Valid for cabling with bottom interface (option 3309-1)</p> <p>Refit the base adapter.</p>	<p>Screw: M3x8 Steel 8.8-A2F (7 pcs) Tightening torque: 1.2 Nm</p>  <p>xx1800003056</p>
5	<p>Refit the connector interface plate to the base.</p>	<p>Screw: M3x30 12.9 Lafre 2C2B/FC6.9 (6 pcs) Tightening torque: 1.2 Nm</p> <p>Valid for cabling with rear interface</p>  <p>xx1800003034</p> <p>Valid for cabling with bottom interface (option 3309-1)</p>  <p>xx1800003055</p>

Continues on next page

5.3.2 Replacing the lower cable package
Continued

Securing the lower cable package to the base

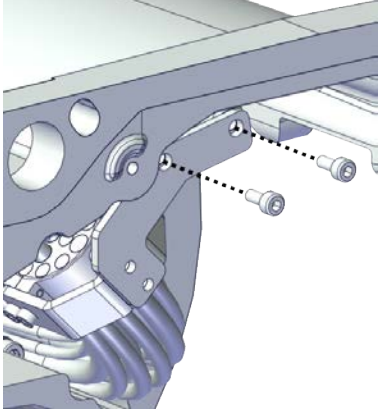
	Action	Note
1	For robots with protection type Clean Room: Clean the joints that have been opened and wipe the parts free from particles with spirit on a lint free.	
2	Refit the cable bracket.	<p>Screw: M2.5x6 12.9 Lafre 2C2B/FC6.9 (2 pcs) Tightening torque: 0.6 Nm</p>  <p>xx1800003042</p>

Securing the brake release button

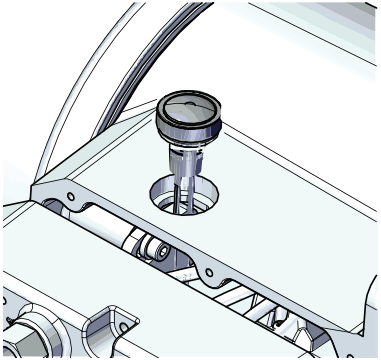
	Action	Note
1	For robots with protection type Clean Room: Clean the joints that have been opened and wipe the parts free from particles with spirit on a lint free.	
2	Tighten the brake release button using the tool.	<p>brake release button assembly tool, included in the special toolkit 3HAC071022-001</p>  <p>xx1800003040</p>

Continues on next page

5 Repair

5.3.2 Replacing the lower cable package

Continued

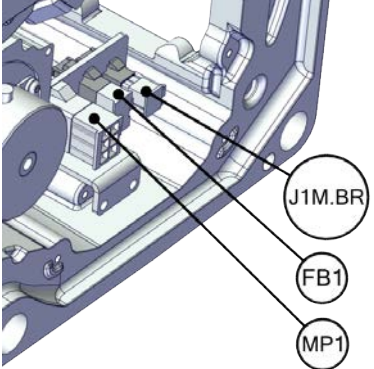
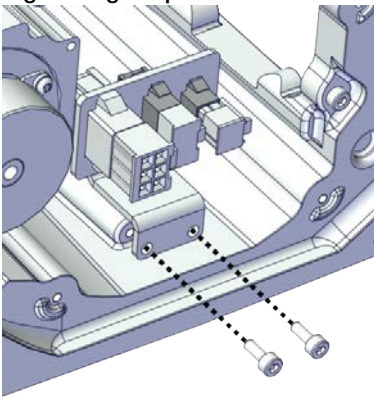
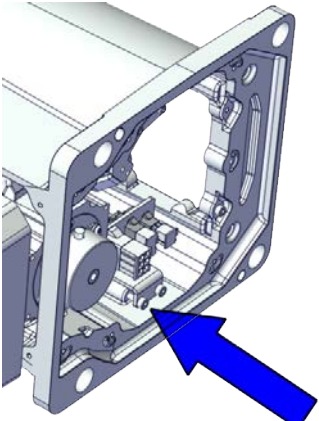

Reconnecting the brake release cabling and axis-1 motor connectors

	Action	Note
1	For robots with protection type Clean Room: Clean the joints that have been opened and wipe the parts free from particles with spirit on a lint free.	
2	Reconnect the connectors. <ul style="list-style-type: none"> • J1M.BR • MP1 • FB1  Tip See the number markings on the connectors for help to find the corresponding connector.	 <p>xx1800003054</p>
3	Reconnect the floor cable together with the connector plate.	Screw: M3x8 12.9 Lafre 2C2B/FC6.9 (2 pcs) Tightening torque: 0.8 Nm  <p>xx1800003037</p>  <p>xx1800003036</p>

Continues on next page

Refitting the base cover

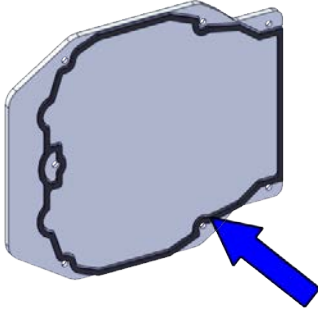
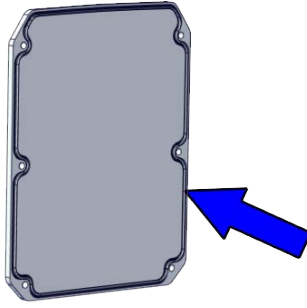
Notice that the procedure differs depending on if the connector interface is located either at the rear or at the bottom of the base.

	Action	Note
1	For robots with protection type Clean Room: Clean the joints that have been opened and wipe the parts free from particles with spirit on a lint free.	
2	For robots with protection class IP67 (option 3350-670) For robots with protection type Clean Room (option 3351-4) Check the gasket. Replace if damaged.	<p>Valid for cabling with rear interface Gasket for base bottom: 3HAC065345-001</p>  <p>xx1900002184</p> <p>Valid for cabling with bottom interface (option 3309-1) Gasket for base rear: 3HAC065350-001</p>  <p>xx1900002189</p>
3	Apply grease to the cable package, cover all moving area of the package.	
4	Apply grease to the covers that have contacting area with the cable package.	
5	Route and secure the cabling with cable straps.  CAUTION Correct cable routing is highly important. If the cables are routed and secured incorrectly the cables can be damaged.	

Continues on next page

5 Repair

5.3.2 Replacing the lower cable package

Continued

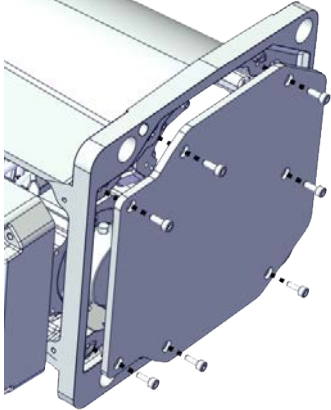
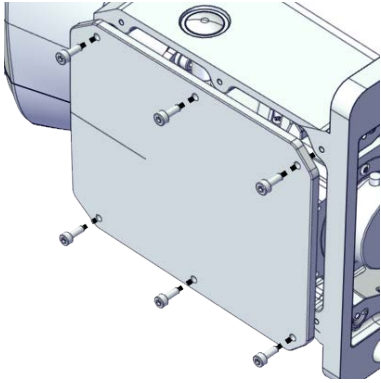

	Action	Note
6	Valid for cabling with rear interface Refit the bottom cover.	Screw: M3x8 Steel 8.8-A2F (7 pcs) Tightening torque: 1.2 Nm  xx1800003035
7	Refit the rear cover.	Screw: M3x8 12.9 Lafre 2C2B/FC6.9 (6 pcs) Tightening torque: 1.2 Nm  xx1800003057

Securing the robot to the foundation

	Action	Note
1	For robots with protection type Clean Room: Clean the joints that have been opened and wipe the parts free from particles with spirit on a lint free.	
2	 CAUTION The IRB 1100 robot weighs 21.1 kg and can be lifted by one person.	
3	Raise the robot to standing and secure to the foundation with the attachment screws and washers.	Attachment screws: M12x25 (robot installation directly on foundation), quality: 8.8. Washers: 24 x 13 x 2.5, steel hardness class 200HV. Tightening Torque: 50 Nm±5 Nm.

Continues on next page

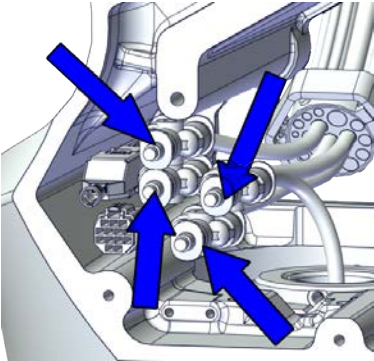
Reconnecting the air hoses, CP/CS cabling and Ethernet cabling (if equipped)

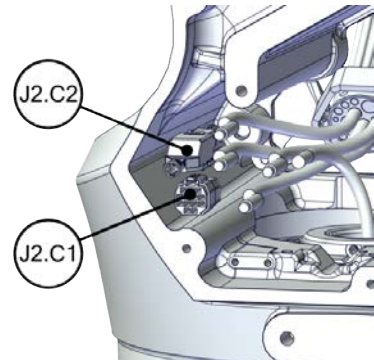
	Action	Note
1	<p>For robots with protection type Clean Room: Clean the joints that have been opened and wipe the parts free from particles with spirit on a lint free.</p>	
2	<p>Reconnect the air hoses in a cross pattern to the Y-shaped connectors.</p> <p> Tip</p> <p>See the number markings on the air hoses for help to find the corresponding air hoses. The air hoses with the same number connect to the same Y-shaped connector.</p>	 <p>xx1800002500</p>
3	<p>Reconnect the connectors.</p> <ul style="list-style-type: none"> • J2.C1 • J2.C2 <p> Tip</p> <p>See the number markings on the connectors for help to find the corresponding connector.</p>	 <p>xx1800002501</p>

Securing the cable package to the swing

	Action	Note
1	<p>For robots with protection type Clean Room: Clean the joints that have been opened and wipe the parts free from particles with spirit on a lint free.</p>	

Continues on next page

5 Repair

5.3.2 Replacing the lower cable package

Continued

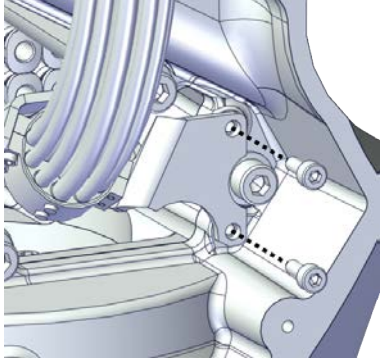

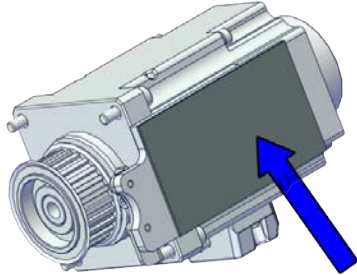

	Action	Note
2	Refit the cable bracket.	<p>Screw: M3x8 12.9 Lafre 2C2B/FC6.9 (2 pcs) Tightening torque: 0.8 Nm</p>  <p>xx1800002499</p>

Refitting the axis-2 motor

	Action	Note
1	For robots with protection type Clean Room: Clean the joints that have been opened and wipe the parts free from particles with spirit on a lint free.	
2	Check that: <ul style="list-style-type: none"> • all assembly surfaces are clean and without damages • the motor is clean and undamaged. 	
3	Check the cooling pad. Replace if damaged, as shown in the following step.	<p>Cooling pad for axis-1 and -2 motors: 3HAC071020-001</p>  <p>xx1800003603</p>

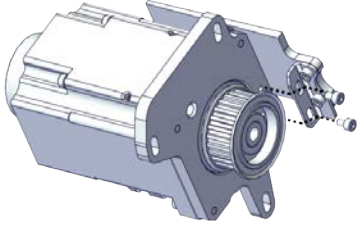
Continues on next page

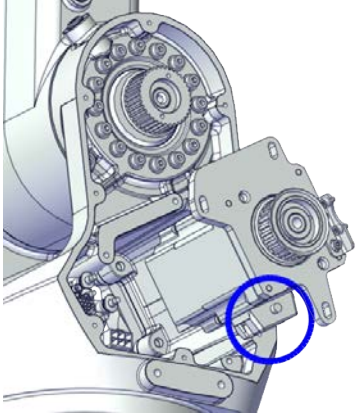
5.3.2 Replacing the lower cable package
Continued

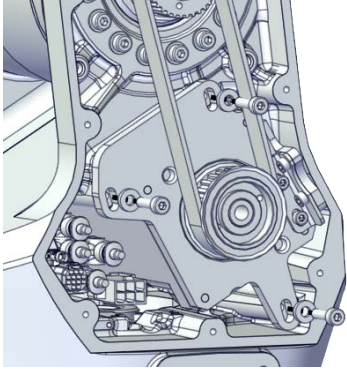

	Action	Note
4	<p>Remove the screws. Replace with a new cooling pad and then refit the screws.</p>	<p>Note Screw: M3x5 12.9 Lafre 2C2B/FC6.9 (2 pcs) Tightening torque: 1.2 Nm</p>  <p>xx1800003026</p>
5	<p>Orient the motor correctly and fit it into the swing.</p> <p> Tip Bend the motor signal cable back towards the swing support.</p>	<p>Note Motor orientation: orient the motor according to the figure below, in regard to the encircled motor connector.</p>  <p>xx1800003027</p>
6	<p>Refit the screws and washers.</p> <p> Note Do not tighten the screws yet.</p>	<p>Note Screw: M4x16 12.9 Lafre 2C2B/FC6.9 (3 pcs) Washer, 3HAC063985-001 (3 pcs)</p>  <p>xx1800002494</p>

Continues on next page

5 Repair

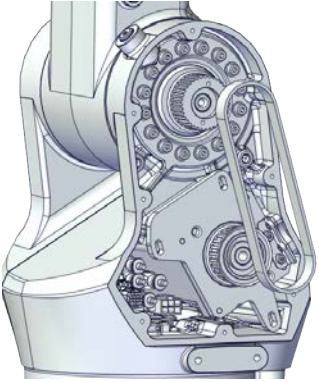

5.3.2 Replacing the lower cable package

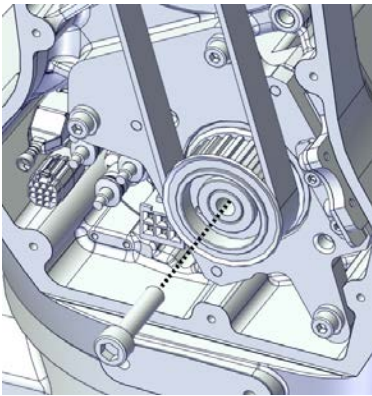
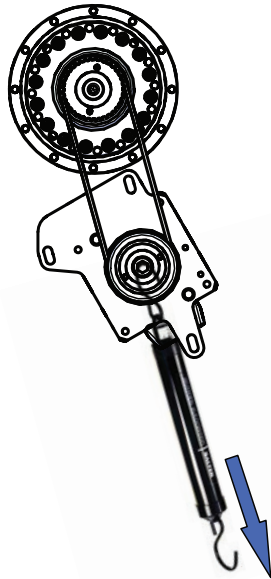
Continued

	Action	Note
7	Install the timing belt to the pulleys and verify that the belt runs correctly in the grooves of the pulleys.	 <p>xx1800003028</p>
8	Install an M6x25 or longer adjustment screw to the motor.  Note Do not insert the entire screw to the hole.	 <p>xx1900000010</p>
9	Use a handheld dynamometer hooking to the screw and pull the dynamometer to reach the initial referenced force.	Initial referenced force for used belt: 68.18-75.04 N (for reference only) Initial referenced force for new belt: 97.4-107.2 N  <p>xx1900000029</p>

Continues on next page

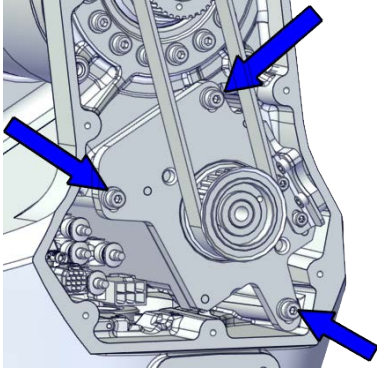
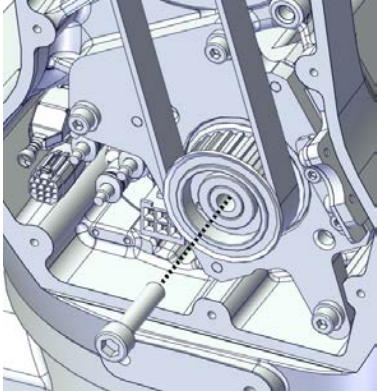
5.3.2 Replacing the lower cable package
Continued

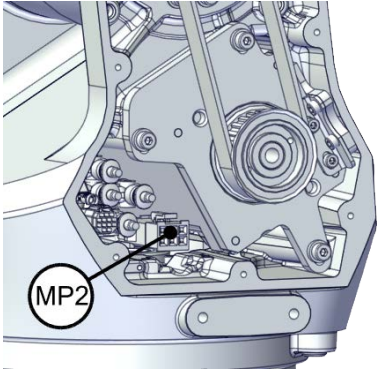
	Action	Note
10	Secure the motor with the screws.	<p>Tightening torque: 3.5 Nm</p>  <p>xx1800002493</p>
11	Use a sonic tension meter to measure the timing belt tension.	<p>Used belt: 163-174 Hz New belt: 180-229 Hz (for reference only)</p>
12	If the timing belt tension does not meet the requirement, loosen the motor screws and readjust.	
13	Remove the adjustment screw from the motor.	 <p>xx1900000010</p>
14	<p>Reconnect the connector.</p> <ul style="list-style-type: none"> • MP2  <p>Tip</p> <p>See the number markings on the connectors for help to find the corresponding connector.</p>	 <p>xx1800002495</p>





Continues on next page

5 Repair

5.3.2 Replacing the lower cable package

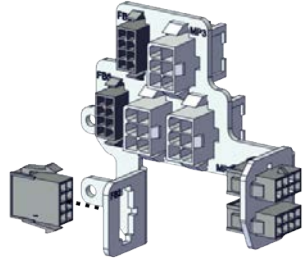
Continued

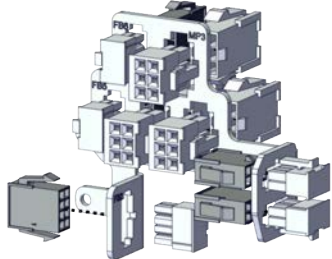
Reconnecting the connectors at the division point

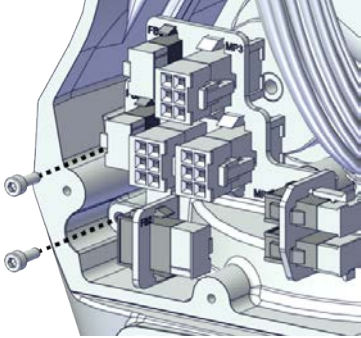
	Action	Note
1	For robots with protection type Clean Room: Clean the joints that have been opened and wipe the parts free from particles with spirit on a lint free.	
2	Insert the female header of the connectors to the connector plate.	 xx1800003029
3	Reconnect the connectors. <ul style="list-style-type: none"> • J2.FB2,3,4,5,6 • J2.MP3,4,5/6  Tip See the number markings on the connectors for help to find the corresponding connector.	 xx1800003030
4	Route and secure the cabling with cable straps.  CAUTION Correct cable routing is highly important. If the cables are routed and secured incorrectly the cables can be damaged.	
5	Refit the connector plate.	Screw: M3x8 12.9 Lafre 2C2B/FC6.9 (2 pcs) Tightening torque: 0.8 Nm  xx1800002489

Continues on next page

Refitting the swing covers

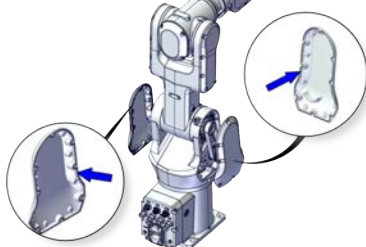
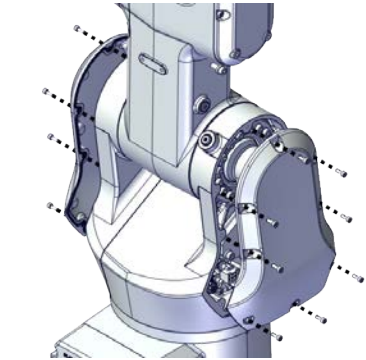
	Action	Note
1	For robots with protection type Clean Room: Clean the joints that have been opened and wipe the parts free from particles with spirit on a lint free.	
2	For robots with protection class IP67 (option 3350-670) For robots with protection type Clean Room (option 3351-4) Check the gaskets. Replace if damaged.	 xx1900002175
3	Apply grease to the cable package, cover all moving area of the package.	
4	Apply grease to the covers that have contacting area with the cable package.	
5	Refit the covers. <ul style="list-style-type: none"> • Swing cover • Swing support cover 	Screw: M3x8 12.9 Lafre 2C2B/FC6.9 Tightening torque: 1.2 Nm  xx1800003607

Concluding procedure

	Action	Note
1	For robots with protection type Clean Room: Clean and paint the joints that have been opened. See Cut the paint or surface on the robot before replacing parts on page 124 .  Note After all repair work, wipe the Clean Room robot free from particles with spirit on a lint free cloth.	
2	Recalibrate the robot.	Calibration is detailed in section Calibration on page 685 .

Continues on next page

5 Repair

5.3.2 Replacing the lower cable package

Continued

	Action	Note
3	 DANGER Make sure all safety requirements are met when performing the first test run. See Test run after installation, maintenance, or repair on page 91 .	

5.3.3 Replacing the SMB unit

Location of the SMB unit

The SMB unit is located as shown in the figure.

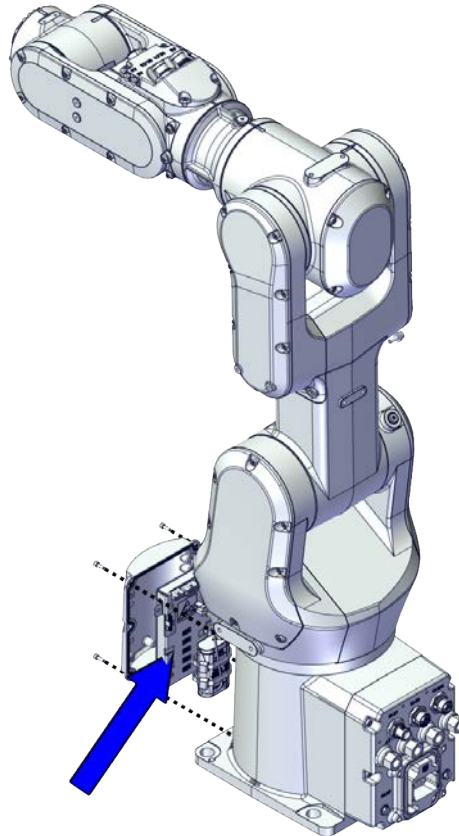

xx1800002464

Required spare parts



Note

The spare part numbers that are listed in the table can be out of date. See the latest spare parts of the IRB 1100 via myABB Business Portal, www.abb.com/myABB.

Spare part	Article number	Note
Serial measurement unit	3HAC063968-001	
SMB cover	3HAC069060-001	
SMB cover, Clean Room	3HAC075506-001	Used with protection type Clean Room.
Gasket for SMB cover	3HAC065344-001	Used with protection class IP67 and protection type Clean Room. Replace if damaged.

Continues on next page

5 Repair

5.3.3 Replacing the SMB unit

Continued

Spare part	Article number	Note
Battery pack	3HAC044075-001	Battery includes protection circuits. Only replace with the specified spare part or an ABB-approved equivalent.

Required tools and equipment

Equipment	Article number	Note
Standard toolkit	-	Content is defined in section Standard toolkit on page 733 .
Calibration tool box, Axis Calibration	3HAC074119-001	Delivered as a set of calibration tools. Required if Axis Calibration is the valid calibration method for the robot. The tool box also includes a unique calibration pin for IRB 1100 to be fitted to the tool flange during calibration of axis 6.
24 VDC power supply	-	Used to release the motor brakes.

Required consumables and wear parts

Consumable	Article number	Note
Cable straps	-	
Grease	3HAC029132-001	FM 222
Locking liquid	-	Loctite 2400 (or equivalent Loctite 243)

Deciding calibration routine

Decide which calibration routine to be used, based on the information in the table. Depending on which routine is chosen, action might be required prior to beginning the repair work of the robot, see the table.

	Action	Note
1	Decide which calibration routine to use for calibrating the robot. <ul style="list-style-type: none"> Reference calibration. External cable packages (DressPack) and tools can stay fitted on the robot. Fine calibration. All external cable packages (DressPack) and tools must be removed from the robot. 	 Note Calibrating axis 6 always requires tools to be removed from the mounting flange (also for reference calibration) since the mounting flange is used for installation of the calibration tool.
	If the robot is to be calibrated with reference calibration: Find previous reference values for the axis or create new reference values. These values are to be used after the repair procedure is completed, for calibration of the robot. If no previous reference values exist, and no new reference values can be created, then reference calibration is not possible.	Follow the instructions given in the reference calibration routine on the FlexPendant to create reference values. Creating new values requires possibility to move the robot. Read more about reference calibration for Axis Calibration in Reference calibration routine on page 696 .



Continues on next page

Action	Note
<p>If the robot is to be calibrated with fine calibration: Remove all external cable packages (DressPack) and tools from the robot.</p>	

Removing the SMB unit

Use these procedures to remove the SMB unit.

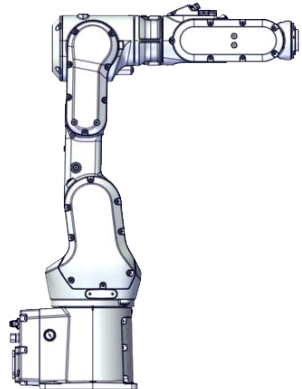
Preparations before removing the SMB unit

Action	Note
1	Decide which calibration routine to use, and take actions accordingly prior to beginning the repair procedure.
2	<p>Jog the robot to the synchronization position.</p>  <p>xx1800003288</p>
3	<p> DANGER</p> <p>Turn off all:</p> <ul style="list-style-type: none"> • electric power supply • hydraulic pressure supply • air pressure supply <p>to the robot, before entering the safeguarded space.</p>
4	<p> CAUTION</p> <p>For robots with protection type Clean Room Always cut the paint with a knife and grind the paint edge when disassembling parts of the robot! See <i>Cut the paint or surface on the robot before replacing parts on page 124.</i></p>







Continues on next page

5 Repair

5.3.3 Replacing the SMB unit

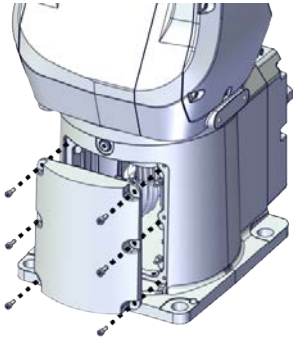

Continued

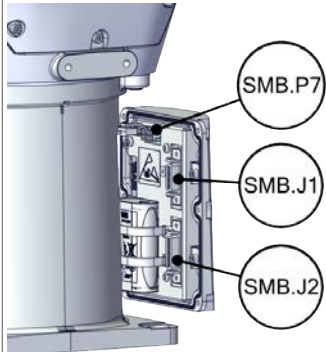
Disconnecting the SMB connectors

	Action	Note
1	 DANGER Make sure that all supplies for electrical power, hydraulic pressure, and air pressure are turned off.	
2	 ELECTROSTATIC DISCHARGE (ESD) The unit is sensitive to ESD. Before handling the unit read the safety information in section The unit is sensitive to ESD on page 49 .	
3	 CAUTION For robots with protection type Clean Room Always cut the paint with a knife and grind the paint edge when disassembling parts of the robot! See Cut the paint or surface on the robot before replacing parts on page 124 .	
4	Remove the SMB cover attachment screws and carefully open the cover.  CAUTION Clean cover from metal residues before opening. Metal residues can cause shortage on the boards which can result in hazardous failures.  CAUTION There are cabling attached to the cover. The cover cannot be removed completely until the connectors are removed.	 <small>xx1800002467</small>
5	Disconnect the connectors. <ul style="list-style-type: none"> • SMB.P7 • SMB.J1 • SMB.J2  Tip Take photos of the connector and cable position before disconnecting them, to have as a reference when reconnecting.	 <small>xx1800002468</small>
6	Remove the SMB cover completely from the base.	

Continues on next page

Removing the battery pack

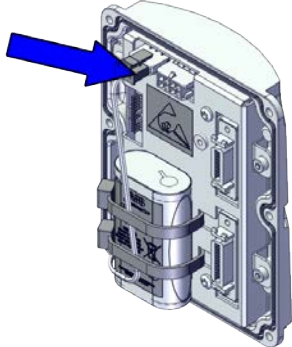
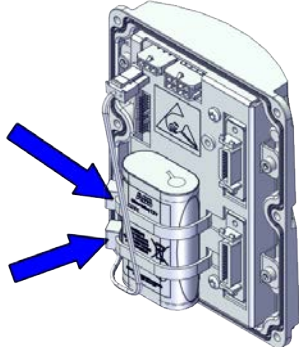
	Action	Note
1	 <p>DANGER</p> <p>Make sure that all supplies for electrical power, hydraulic pressure, and air pressure are turned off.</p>	
2	 <p>ELECTROSTATIC DISCHARGE (ESD)</p> <p>The unit is sensitive to ESD. Before handling the unit read the safety information in section The unit is sensitive to ESD on page 49.</p>	
3	 <p>CAUTION</p> <p>For robots with protection type Clean Room</p> <p>Always cut the paint with a knife and grind the paint edge when disassembling parts of the robot! See Cut the paint or surface on the robot before replacing parts on page 124.</p>	
4	<p>Disconnect the battery cable.</p>	 <p>xx1800002469</p>
5	<p>Remove the battery pack by cutting the cable strap.</p>	 <p>xx1800002470</p>



Continues on next page

5 Repair

5.3.3 Replacing the SMB unit

Continued

Removing the SMB unit

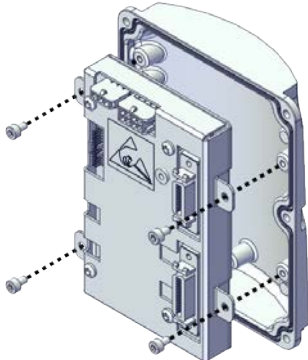
	Action	Note
1	 DANGER Make sure that all supplies for electrical power, hydraulic pressure, and air pressure are turned off.	
2	 ELECTROSTATIC DISCHARGE (ESD) The unit is sensitive to ESD. Before handling the unit read the safety information in section The unit is sensitive to ESD on page 49 .	
3	 CAUTION For robots with protection type Clean Room Always cut the paint with a knife and grind the paint edge when disassembling parts of the robot! See Cut the paint or surface on the robot before replacing parts on page 124 .	
4	Remove the screws.	 xx1800002471

Refitting the SMB unit

Use these procedures to refit the SMB unit.

Refitting the SMB unit

	Action	Note
1	 ELECTROSTATIC DISCHARGE (ESD) The unit is sensitive to ESD. Before handling the unit read the safety information in section The unit is sensitive to ESD on page 49 .	

Continues on next page

5.3.3 Replacing the SMB unit
Continued

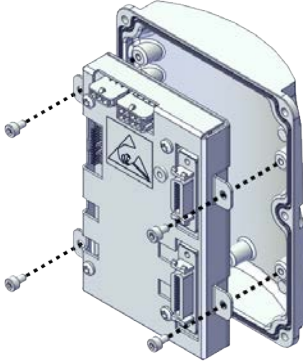
	Action	Note
2	For robots with protection type Clean Room: Clean the joints that have been opened and wipe the parts free from particles with spirit on a lint free.	
3	Refit the screws.	<p>Screw: M3x5 12.9 Lafre 2C2B/FC6.9 (4 pcs) Tightening torque: 0.8 Nm</p>  <p>xx1800002471</p>

Refitting the battery pack

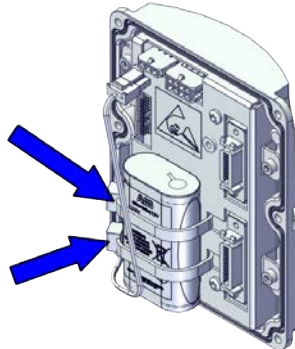
	Action	Note
1	 <p>ELECTROSTATIC DISCHARGE (ESD)</p> <p>The unit is sensitive to ESD. Before handling the unit read the safety information in section The unit is sensitive to ESD on page 49.</p>	
2	For robots with protection type Clean Room: Clean the joints that have been opened and wipe the parts free from particles with spirit on a lint free.	
3	Secure the battery pack using the cable strap.	 <p>xx1800002470</p>

Continues on next page



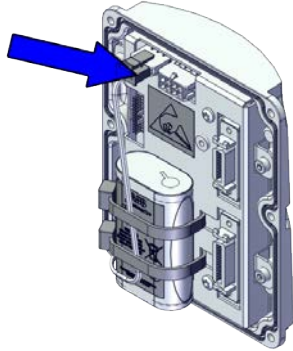

5 Repair

5.3.3 Replacing the SMB unit

Continued

	Action	Note
4	Reconnect the battery cable.	 <p>xx1800002469</p>

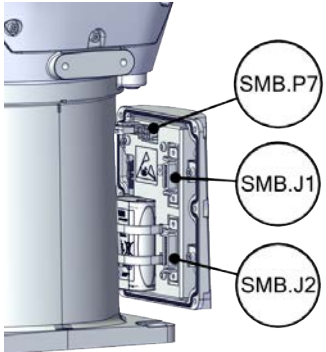

Reconnecting the SMB connectors

	Action	Note
1	 <p>ELECTROSTATIC DISCHARGE (ESD)</p> <p>The unit is sensitive to ESD. Before handling the unit read the safety information in section The unit is sensitive to ESD on page 49.</p>	
2	<p>For robots with protection type Clean Room</p> <p>Clean the joints that have been opened and wipe the parts free from particles with spirit on a lint free.</p>	
3	<p>Reconnect the connectors.</p> <ul style="list-style-type: none"> • SMB.P7 • SMB.J1 • SMB.J2 <p> Tip</p> <p>See the number markings on the connectors for help to find the corresponding connector.</p>	<p>Tightening torque: 0.3 Nm</p>  <p>xx1800002468</p>
4	<p>Route and secure the cabling with cable straps.</p> <p> CAUTION</p> <p>Correct cable routing is highly important. If the cables are routed and secured incorrectly the cables can be damaged.</p>	

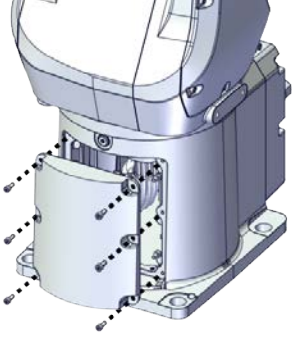
Continues on next page

	Action	Note
5	Refit the SMB cover to the base.	<p>Screw: M3x8 12.9 Lafre 2C2B/FC6.9 (6 pcs) Tightening torque: 1.2 Nm</p>  <p>xx1800002467</p>

Concluding procedure

	Action	Note
1	<p>For robots with protection type Clean Room: Clean and paint the joints that have been opened. See Cut the paint or surface on the robot before replacing parts on page 124.</p> <p> Note</p> <p>After all repair work, wipe the Clean Room robot free from particles with spirit on a lint free cloth.</p>	
2	Recalibrate the robot.	Calibration is detailed in section Calibration on page 685 .
3	<p> DANGER</p> <p>Make sure all safety requirements are met when performing the first test run. See Test run after installation, maintenance, or repair on page 91.</p>	

5 Repair

5.4.1 Replacing the base

5.4 Swing and base

5.4.1 Replacing the base

Location of the base

The base is located as shown in the figure.

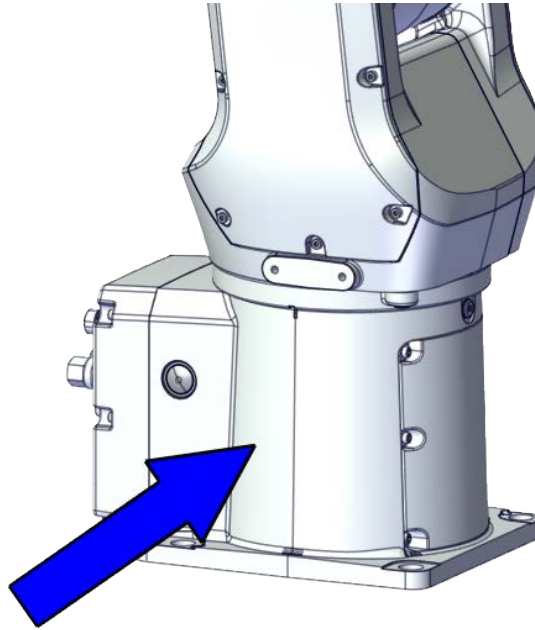

xx1800002472

Required spare parts



Note

The spare part numbers that are listed in the table can be out of date. See the latest spare parts of the IRB 1100 via myABB Business Portal, www.abb.com/myABB.

Spare part	Article number	Note
Lower cable harness, basic	3HAC075521-001	Used with protection classes IP40 and IP67.
Lower cable harness, basic, Clean Room	3HAC075514-001	Used with protection type Clean Room.
Lower cable harness (CP/CS and air hose, without Ethernet)	3HAC075522-001	Used with protection classes IP40 and IP67.
Lower cable harness, Clean Room (CP/CS and air hose, without Ethernet)	3HAC075515-001	Used with protection type Clean Room.
Lower cable harness (CP/CS and air hose, with Ethernet)	3HAC075523-001	Used with protection classes IP40 and IP67.

Continues on next page

Spare part	Article number	Note
Lower cable harness, Clean Room (CP/CS and air hose, with Ethernet)	3HAC075581-001	Used with protection type Clean Room.
Base	3HAC069048-001	
Base with sealing ring	3HAC074270-001	Used with protection class IP67.
Base with sealing ring, Clean Room	3HAC075488-001	Used with protection type Clean Room.
Axis-1 radial sealing	3HAC070148-005	Used with protection class IP67 and protection type Clean Room. Replace if damaged.
Motor with flange, axis 1	3HAC083589-001	
Timing belt, axis 1	3HAC061934-001	
Motor with flange, axis 2	3HAC083588-001	.
Timing belt, axis 2	3HAC061935-001	
Mechanical stop, axis 1	3HAC061947-001	Replace if damaged.
Base bottom cover	3HAC060463-001	Standard configuration, used for robots with rear connector interface.
Base rear cover	3HAC070312-001	Used for robots with bottom connector interface.
Base rear cover, Clean Room	3HAC075513-001	Used for robots with bottom connector interface. Used with protection type Clean Room.
Base adapter	3HAC070313-001	Used for robots with bottom connector interface.
Base adapter, Clean Room	3HAC075793-001	Used for robots with bottom connector interface. Used with protection type Clean Room.
Swing cover	3HAC069051-001	
Swing cover, Clean Room	3HAC075498-001	Used with protection type Clean Room.
Swing support cover	3HAC069052-001	
Swing support cover, Clean Room	3HAC075500-001	Used with protection type Clean Room.
SMB cover	3HAC069060-001	
SMB cover, Clean Room	3HAC075506-001	Used with protection type Clean Room.
Gasket for base bottom	3HAC065345-001	Used with protection class IP67 and protection type Clean Room. Replace if damaged.
Gasket for base rear	3HAC065350-001	Used with protection class IP67 and protection type Clean Room. Replace if damaged.

Continues on next page

5 Repair

5.4.1 Replacing the base

Continued

Spare part	Article number	Note
Gasket for swing cover	3HAC061959-003	Used with protection class IP67 and protection type Clean Room. Replace if damaged.
Gasket for swing support cover	3HAC065317-001	Used with protection class IP67 and protection type Clean Room. Replace if damaged.
Gasket for SMB cover	3HAC065344-001	Used with protection class IP67 and protection type Clean Room. Replace if damaged.
Cooling pad for axis-1 and -2 motors	3HAC071020-001	Cooling pads are wear parts. One cooling pad sheet contains 6 pieces of small pad. Replace if damaged with one piece each time.
Washer	3HAC063985-001	9x4.3x1, Steel

Required tools and equipment

Equipment	Article number	Note
Standard toolkit	-	Content is defined in section Standard toolkit on page 733 .
Calibration tool box, Axis Calibration	3HAC074119-001	Delivered as a set of calibration tools. Required if Axis Calibration is the valid calibration method for the robot. The tool box also includes a unique calibration pin for IRB 1100 to be fitted to the tool flange during calibration of axis 6.
24 VDC power supply	-	Used to release the motor brakes.
Sonic tension meter	-	Used for measuring the timing belt tension.
Dynamometer	-	Used for measuring the timing belt tension.
brake release button assembly tool	-	Included in the special toolkit 3HAC071022-001. Used to remove and refit the brake release button.

Required consumables

Consumable	Article number	Note
Cable straps	-	
Grease	3HAC029132-001	FM 222
Locking liquid	-	Loctite 2400 (or equivalent Loctite 243)

Continues on next page

Deciding calibration routine

Decide which calibration routine to be used, based on the information in the table. Depending on which routine is chosen, action might be required prior to beginning the repair work of the robot, see the table.

	Action	Note
1	<p>Decide which calibration routine to use for calibrating the robot.</p> <ul style="list-style-type: none"> Reference calibration. External cable packages (DressPack) and tools can stay fitted on the robot. Fine calibration. All external cable packages (DressPack) and tools must be removed from the robot. 	<p> Note</p> <p>Calibrating axis 6 always requires tools to be removed from the mounting flange (also for reference calibration) since the mounting flange is used for installation of the calibration tool.</p>
	<p>If the robot is to be calibrated with reference calibration:</p> <p>Find previous reference values for the axis or create new reference values. These values are to be used after the repair procedure is completed, for calibration of the robot.</p> <p>If no previous reference values exist, and no new reference values can be created, then reference calibration is not possible.</p>	<p>Follow the instructions given in the reference calibration routine on the FlexPendant to create reference values.</p> <p>Creating new values requires possibility to move the robot.</p> <p>Read more about reference calibration for Axis Calibration in Reference calibration routine on page 696.</p>
	<p>If the robot is to be calibrated with fine calibration:</p> <p>Remove all external cable packages (DressPack) and tools from the robot.</p>	

Removing the base

Use these procedures to remove the base.

Preparations before removing the base

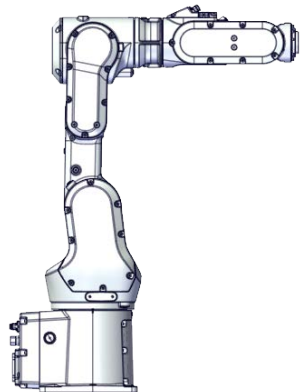

	Action	Note
1	Decide which calibration routine to use, and take actions accordingly prior to beginning the repair procedure.	
2	Jog all axes to zero position.	 <p>xx1800003288</p>

Continues on next page



5 Repair

5.4.1 Replacing the base





Continued

	Action	Note
3	 DANGER Turn off all: <ul style="list-style-type: none">• electric power supply• hydraulic pressure supply• air pressure supply to the robot, before entering the safeguarded space.	
4	 CAUTION For robots with protection type Clean Room Always cut the paint with a knife and grind the paint edge when disassembling parts of the robot! See Cut the paint or surface on the robot before replacing parts on page 124.	

Removing the axis-2 motor

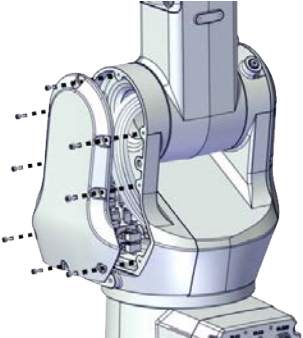
	Action	Note
1	 DANGER Make sure that all supplies for electrical power, hydraulic pressure, and air pressure are turned off.	
2	 CAUTION For robots with protection type Clean Room Always cut the paint with a knife and grind the paint edge when disassembling parts of the robot! See Cut the paint or surface on the robot before replacing parts on page 124.	
3	 CAUTION Removing motors will release axes. This means the axes can fall down. Make sure axes are well supported before removing motors.	

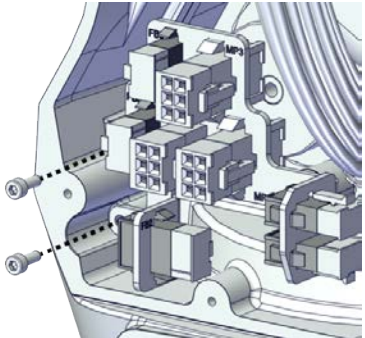

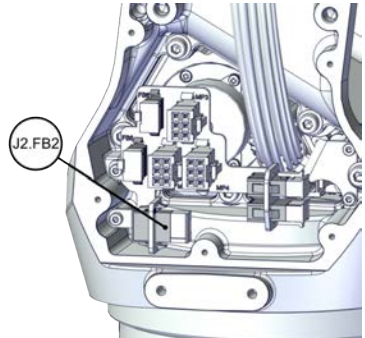
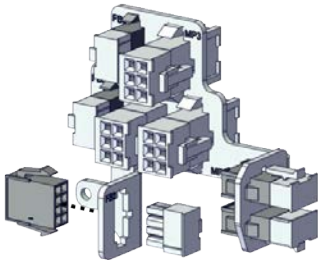
Continues on next page

	Action	Note
4	Remove the swing support cover.	 <p>xx1800002488</p>
5	Remove the connector plate.  CAUTION Be aware of the cablings that are attached to the connector plate! The connector plate cannot be removed completely until the connectors are removed from the plate.	 <p>xx1800002489</p>
6	Disconnect the connector. • J2.FB2  Tip Take photos of the connector and cable position before disconnecting them, to have as a reference when reconnecting.	 <p>xx1800002490</p>
7	Snap loose and remove the female head of the connector from the connector plate.	 <p>xx1800002491</p>

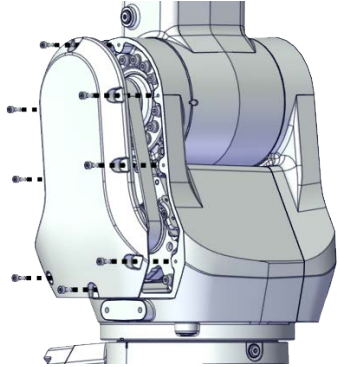

5 Repair

5.4.1 Replacing the base

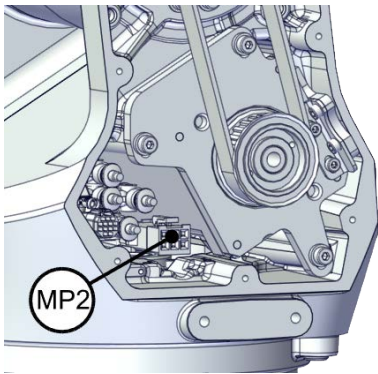
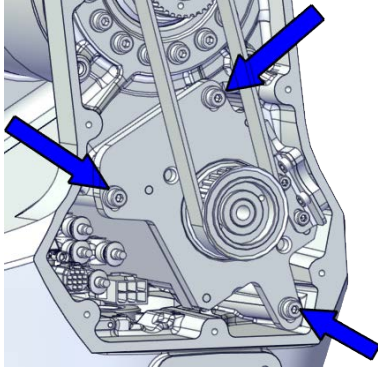
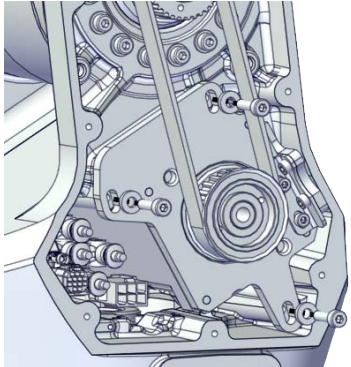

Continued

	Action	Note
8	Remove the swing cover.	 xx1800002492
9	Disconnect the connector. <ul style="list-style-type: none">• MP2  Tip Take photos of the connector and cable position before disconnecting them, to have as a reference when reconnecting.	 xx1800002495
10	Loosen the screws and move the motor slightly to slacken the timing belt.	 xx1800002493
11	Remove the screws and washers.	 xx1800002494

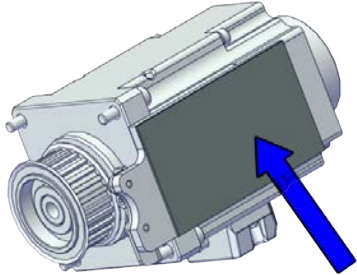
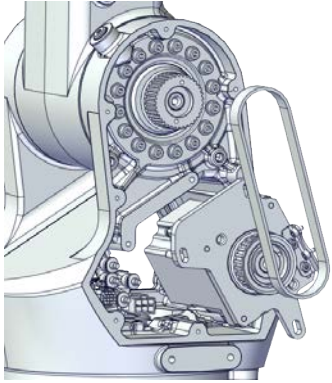
Continues on next page

	Action	Note
12	<p>Carefully lift out the motor.</p> <p> CAUTION</p> <p>A cooling pad is attached to the motor, which may stick to the casting. Always use a plastic sheet with caution to remove the pad from the casting. Pay attention not to scratch the casting or damage the pad.</p> <p> CAUTION</p> <p>Be aware of the motor cabling. The motor cannot be removed completely until the connector is disconnected, as shown in following step.</p>	<p>Cooling pad location</p>  <p>xx1800003603</p>
13	<p>Remove the timing belt from its groove on the motor.</p>	 <p>xx1800002496</p>

Loosening the cable package from axis-1 gearbox

	Action	Note
1	<p> DANGER</p> <p>Make sure that all supplies for electrical power, hydraulic pressure, and air pressure are turned off.</p>	
2	<p> CAUTION</p> <p>For robots with protection type Clean Room</p> <p>Always cut the paint with a knife and grind the paint edge when disassembling parts of the robot! See Cut the paint or surface on the robot before replacing parts on page 124.</p>	

Continues on next page



5 Repair

5.4.1 Replacing the base

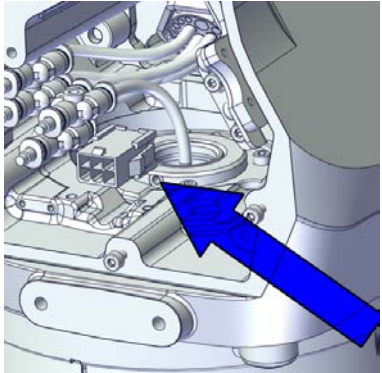
Continued

	Action	Note
3	Access the cable package locking screw on the axis-1 gearbox from the swing and then loosen the locking screw.	 xx1800003032
4	Remove the locking screw.	

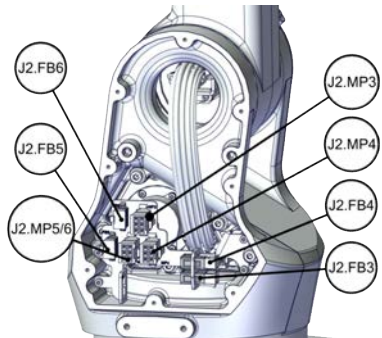

Disconnecting the connectors at the division point

	Action	Note
1	 DANGER Make sure that all supplies for electrical power, hydraulic pressure, and air pressure are turned off.	
2	 CAUTION For robots with protection type Clean Room Always cut the paint with a knife and grind the paint edge when disassembling parts of the robot! See Cut the paint or surface on the robot before replacing parts on page 124 .	
3	Disconnect the connectors. <ul style="list-style-type: none"> • J2.FB3,4,5,6 • J2.MP3,4,5/6  Tip Take photos of the connector and cable position before disconnecting them, to have as a reference when reconnecting.	 xx1800002497

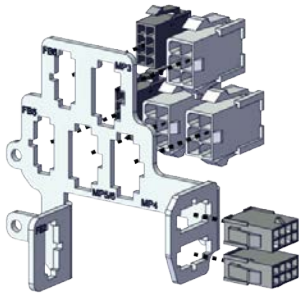
Continues on next page

	Action	Note
4	Snap loose and remove the female head of the connectors from the connector plate.	 xx1800002498

Separating the cable package from the swing

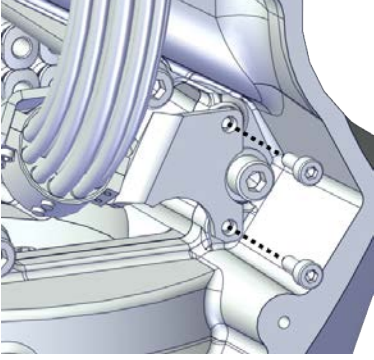
	Action	Note
1	 DANGER Make sure that all supplies for electrical power, hydraulic pressure, and air pressure are turned off.	
2	 CAUTION For robots with protection type Clean Room Always cut the paint with a knife and grind the paint edge when disassembling parts of the robot! See Cut the paint or surface on the robot before replacing parts on page 124 .	
3	Remove the cable bracket.	 xx1800002499

Disconnecting the air hoses, CP/CS cabling and Ethernet cabling (if equipped)



	Action	Note
1	 DANGER Make sure that all supplies for electrical power, hydraulic pressure, and air pressure are turned off.	

Continues on next page

5 Repair



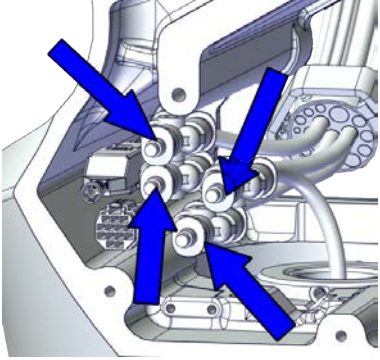

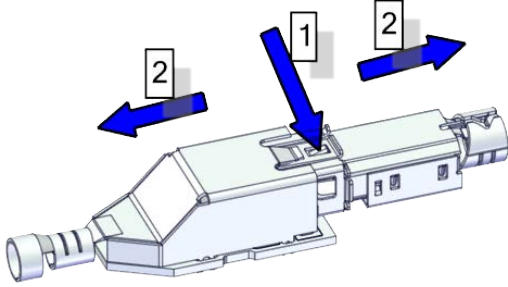
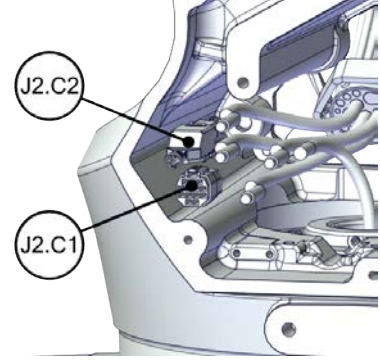
5.4.1 Replacing the base

Continued

	Action	Note
2	<p> CAUTION</p> <p>For robots with protection type Clean Room Always cut the paint with a knife and grind the paint edge when disassembling parts of the robot! See Cut the paint or surface on the robot before replacing parts on page 124.</p>	
3	Disconnect the air hoses from the Y-shaped connectors.	 <p>xx1800002500</p>
4	<p>Disconnect the connectors.</p> <ul style="list-style-type: none">• J2.C1• J2.C2 <p> Tip</p> <p>Take photos of the connector and cable position before disconnecting them, to have as a reference when reconnecting.</p> <p> Tip</p> <p>The connector clip has to be pressed (1) and pushed forward (2) to separate the J2.C2 (for Ethernet cabling).</p>  <p>xx1800002943</p>	 <p>xx1800002501</p>

Continues on next page

Putting the robot on its side

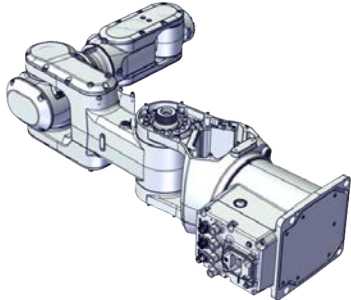
	Action	Note
1	 DANGER Make sure that all supplies for electrical power, hydraulic pressure, and air pressure are turned off.	
2	 CAUTION For robots with protection type Clean Room Always cut the paint with a knife and grind the paint edge when disassembling parts of the robot! See <i>Cut the paint or surface on the robot before replacing parts on page 124.</i>	
3	 CAUTION The IRB 1100 robot weighs 21.1 kg and can be lifted by one person.	
4	 WARNING The robot is likely to be mechanically unstable if not secured to the foundation.	
5	Loosen the robot from the foundation by removing the foundation attachment screws and put the robot on its side.	 xx1800003033

Disconnecting the SMB connectors







	Action	Note
1	 DANGER Make sure that all supplies for electrical power, hydraulic pressure, and air pressure are turned off.	

Continues on next page

5 Repair

5.4.1 Replacing the base

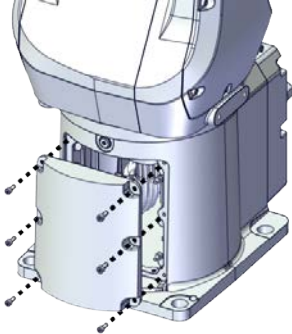

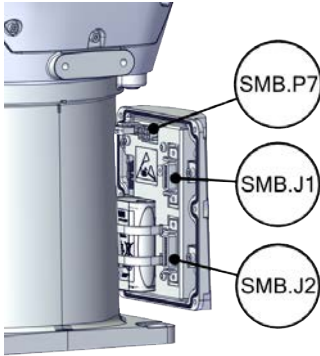
Continued

	Action	Note
2	 ELECTROSTATIC DISCHARGE (ESD) The unit is sensitive to ESD. Before handling the unit read the safety information in section The unit is sensitive to ESD on page 49 .	
3	 CAUTION For robots with protection type Clean Room Always cut the paint with a knife and grind the paint edge when disassembling parts of the robot! See Cut the paint or surface on the robot before replacing parts on page 124 .	
4	Remove the SMB cover attachment screws and carefully open the cover.  CAUTION Clean cover from metal residues before opening. Metal residues can cause shortage on the boards which can result in hazardous failures.  CAUTION There are cabling attached to the cover. The cover cannot be removed completely until the connectors are removed.	 <small>xx1800002467</small>
5	Disconnect the connectors. <ul style="list-style-type: none"> • SMB.P7 • SMB.J1 • SMB.J2  Tip Take photos of the connector and cable position before disconnecting them, to have as a reference when reconnecting.	 <small>xx1800002468</small>
6	Remove the SMB cover completely from the base.	

Opening the connector interface plate

	Action	Note
1	 DANGER Make sure that all supplies for electrical power, hydraulic pressure, and air pressure are turned off.	

Continues on next page

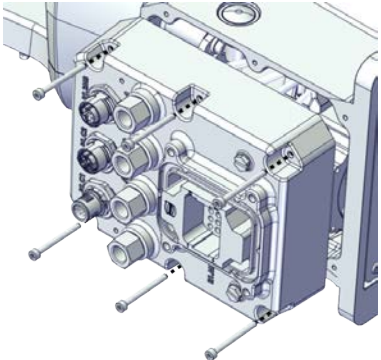
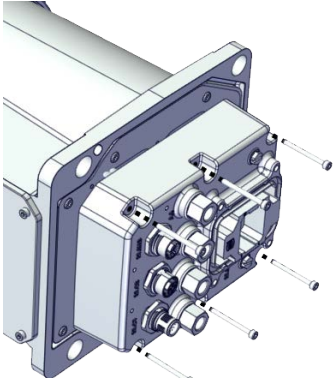
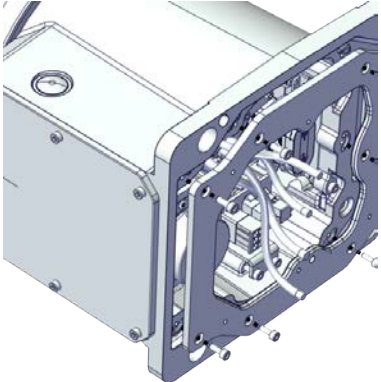
	Action	Note
2	<p> CAUTION</p> <p>For robots with protection type Clean Room Always cut the paint with a knife and grind the paint edge when disassembling parts of the robot! See <i>Cut the paint or surface on the robot before replacing parts on page 124.</i></p>	
3	<p>Remove the connector interface plate attachment screws and carefully open the plate.</p> <p> CAUTION</p> <p>There are cabling attached to the cover. The cover cannot be removed completely until the connectors are removed.</p>	<p>Valid for cabling with rear interface</p>  <p>xx1800003034</p> <p>Valid for cabling with bottom interface (option 3309-1)</p>  <p>xx1800003055</p>
4	<p>Valid for cabling with bottom interface (option 3309-1)</p> <p>Remove the base adapter.</p>	 <p>xx1800003056</p>

Continues on next page



5 Repair

5.4.1 Replacing the base



Continued

Removing the brake release button

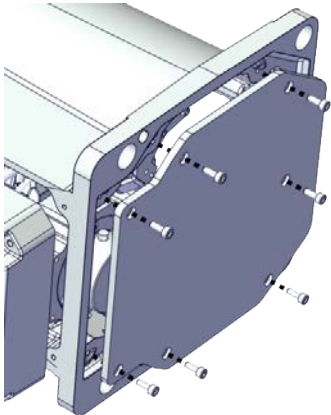
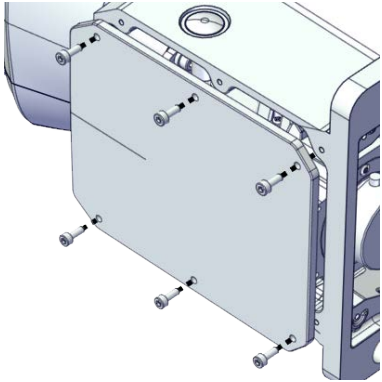
Notice that the procedure differs depending on if the connector interface is located either at the rear or at the bottom of the base.

	Action	Note
1	 DANGER Make sure that all supplies for electrical power, hydraulic pressure, and air pressure are turned off.	
2	 CAUTION For robots with protection type Clean Room Always cut the paint with a knife and grind the paint edge when disassembling parts of the robot! See Cut the paint or surface on the robot before replacing parts on page 124 .	
3	Valid for cabling with rear interface Remove the base bottom cover.	 xx1800003035
4	Valid for cabling with bottom interface (option 3309-1) Remove the base rear cover.	 xx1800003057

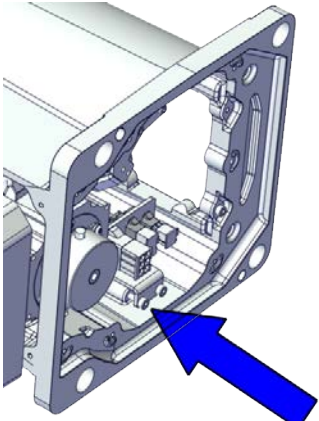
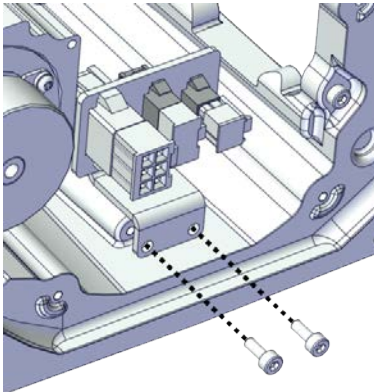
Continues on next page

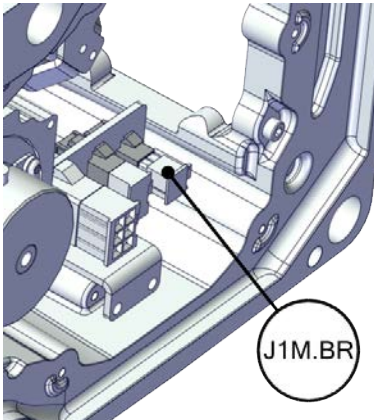
	Action	Note
5	Disconnect the earth cable.	 <p>xx1800003036</p>
6	Remove the connector plate.	 <p>xx1800003037</p>
7	Disconnect the connector. <ul style="list-style-type: none"> • J1M.BR  Tip Take photos of the connector and cable position before disconnecting them, to have as a reference when reconnecting.	 <p>xx1800003038</p>

Continues on next page



5 Repair

5.4.1 Replacing the base

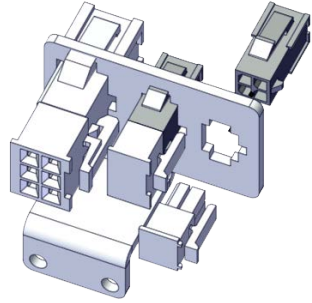
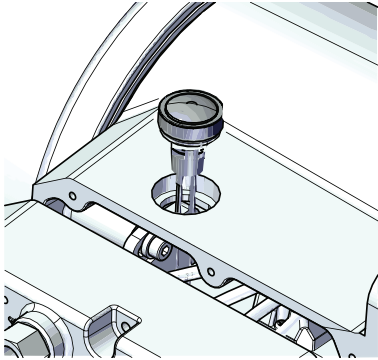
Continued

	Action	Note
8	Remove the female header of the J1M.BR connector from the connector plate.	 xx1800003039
9	Remove the brake release button from the base using the tool.	brake release button assembly tool, included in the special toolkit 3HAC071022-001  xx1800003040



Disconnecting axis-1 motor connectors

	Action	Note
1	 DANGER Make sure that all supplies for electrical power, hydraulic pressure, and air pressure are turned off.	
2	 CAUTION For robots with protection type Clean Room Always cut the paint with a knife and grind the paint edge when disassembling parts of the robot! See Cut the paint or surface on the robot before replacing parts on page 124.	

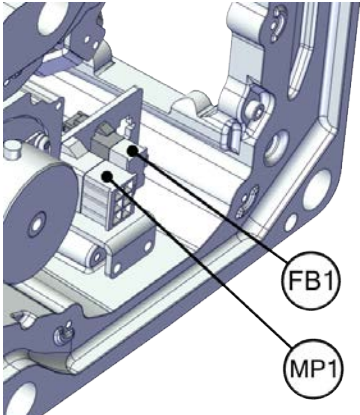
Continues on next page

	Action	Note
3	<p>Disconnect the connectors.</p> <ul style="list-style-type: none"> • FB1 • MP1 <p> Tip</p> <p>Take photos of the connector and cable position before disconnecting them, to have as a reference when reconnecting.</p>	 <p>xx1800003041</p>

Separating the cable package from the base

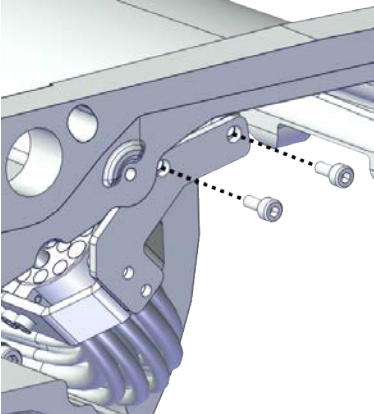
	Action	Note
1	<p> DANGER</p> <p>Make sure that all supplies for electrical power, hydraulic pressure, and air pressure are turned off.</p>	
2	<p> CAUTION</p> <p>For robots with protection type Clean Room</p> <p>Always cut the paint with a knife and grind the paint edge when disassembling parts of the robot! See Cut the paint or surface on the robot before replacing parts on page 124.</p>	
3	<p>Remove the cable bracket.</p>	 <p>xx1800003042</p>



Continues on next page

5 Repair



5.4.1 Replacing the base

Continued

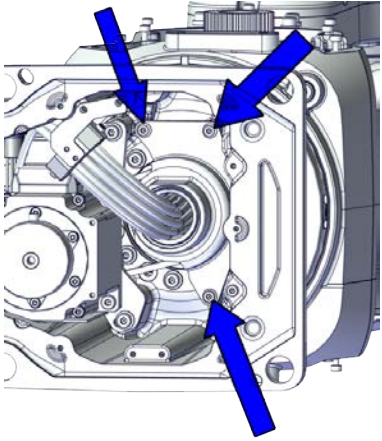
Separating the cable package from the axis-1 gearbox

	Action	Note
1	 DANGER Make sure that all supplies for electrical power, hydraulic pressure, and air pressure are turned off.	
2	 CAUTION For robots with protection type Clean Room Always cut the paint with a knife and grind the paint edge when disassembling parts of the robot! See Cut the paint or surface on the robot before replacing parts on page 124 .	
3	Remove the pulley cover.	 xx1800003043

Pulling out the cable package

	Action	Note
1	 DANGER Make sure that all supplies for electrical power, hydraulic pressure, and air pressure are turned off.	
2	 CAUTION For robots with protection type Clean Room Always cut the paint with a knife and grind the paint edge when disassembling parts of the robot! See Cut the paint or surface on the robot before replacing parts on page 124 .	

Continues on next page

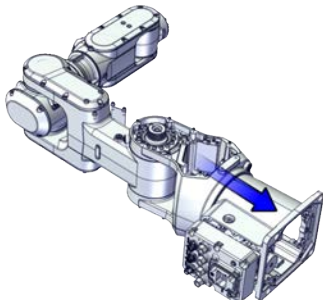
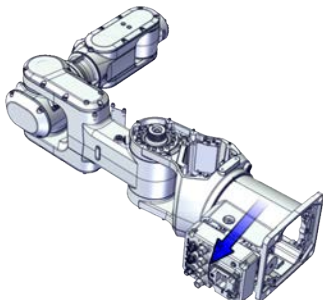
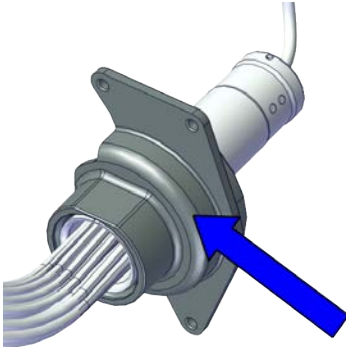
	Action	Note
3	Pull out the lower cable package from the axis-1 gearbox.	 <p>xx1800003044</p>
4	Pull out the lower cable package from the base.	 <p>xx1800003045</p>
5	Remove the pulley cover from the lower cable package.	 <p>xx1800003046</p>

Removing the axis-1 motor



	Action	Note
1	 <p>DANGER</p> <p>Make sure that all supplies for electrical power, hydraulic pressure, and air pressure are turned off.</p>	

Continues on next page

5 Repair

5.4.1 Replacing the base

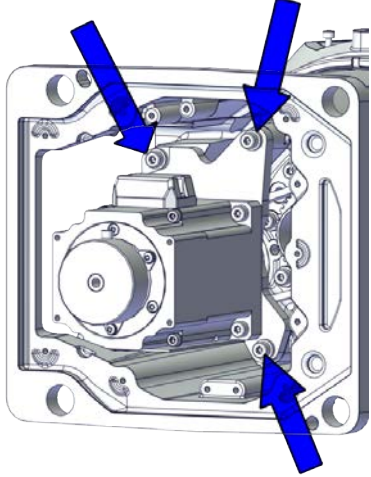
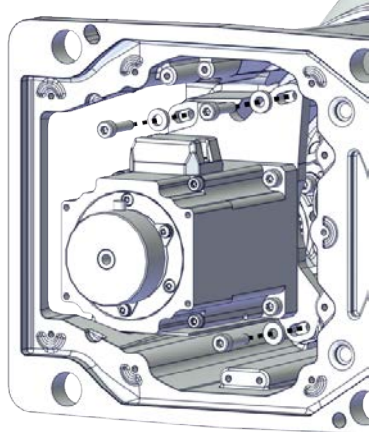

Continued

	Action	Note
2	<p> CAUTION</p> <p>For robots with protection type Clean Room Always cut the paint with a knife and grind the paint edge when disassembling parts of the robot! See Cut the paint or surface on the robot before replacing parts on page 124.</p>	
3	<p> CAUTION</p> <p>Removing motors will release axes. This means the axes can fall down. Make sure axes are well supported before removing motors.</p>	
4	<p>Loosen the screws and move the motor slightly to slacken the timing belt.</p>	 <p>xx1800003064</p>
5	<p>Remove the screws and washers.</p>	 <p>xx1800003065</p>

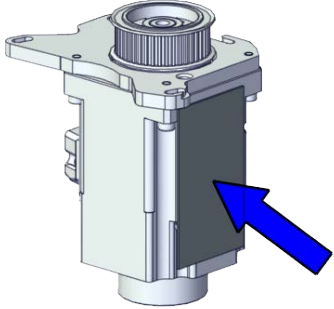
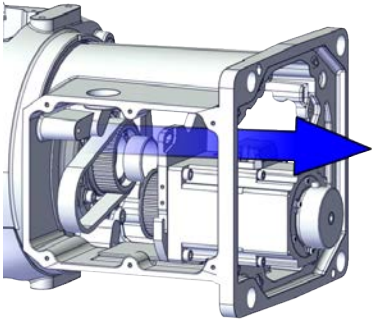
Continues on next page

	Action	Note
6	<p>Carefully lift out the motor.</p> <p> CAUTION</p> <p>A cooling pad is attached to the motor, which may stick to the casting. Always use a plastic sheet with caution to remove the pad from the casting. Pay attention not to scratch the casting or damage the pad.</p>	<p>Cooling pad location</p>  <p>xx1800003602</p>
7	<p>Remove the timing belt from its groove on the motor.</p>	 <p>xx1800003066</p>

Removing the axis-1 timing belt

	Action	Note
1	<p> DANGER</p> <p>Make sure that all supplies for electrical power, hydraulic pressure, and air pressure are turned off.</p>	
2	<p> CAUTION</p> <p>For robots with protection type Clean Room</p> <p>Always cut the paint with a knife and grind the paint edge when disassembling parts of the robot! See Cut the paint or surface on the robot before replacing parts on page 124.</p>	
3	<p> CAUTION</p> <p>Loosening timing belts will release axes. This means the axes can fall down.</p> <p>Make sure axes are well supported before loosening timing belts.</p>	

Continues on next page



5 Repair

5.4.1 Replacing the base

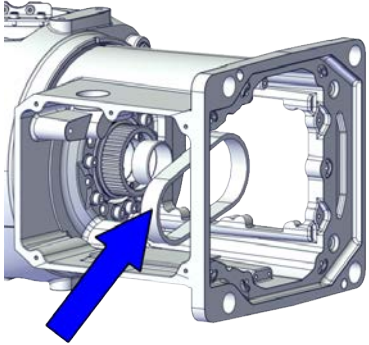

Continued

	Action	Note
4	Remove the timing belt from its groove on the gearbox.	 <p>xx1800003067</p>

Separating the base from the swing

	Action	Note
1	 DANGER Make sure that all supplies for electrical power, hydraulic pressure, and air pressure are turned off.	
2	 CAUTION For robots with protection type Clean Room Always cut the paint with a knife and grind the paint edge when disassembling parts of the robot! See Cut the paint or surface on the robot before replacing parts on page 124 .	

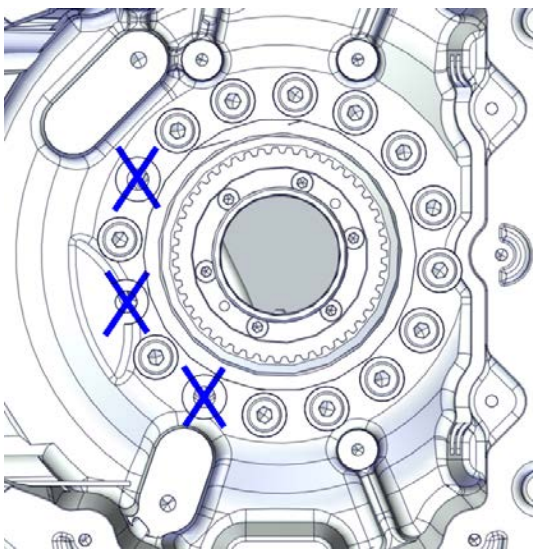
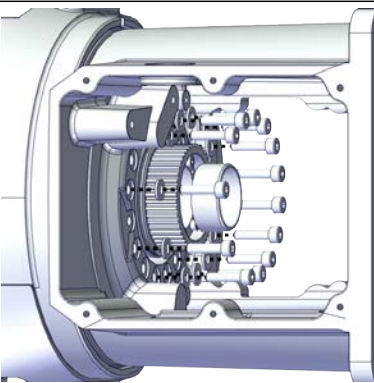
Continues on next page

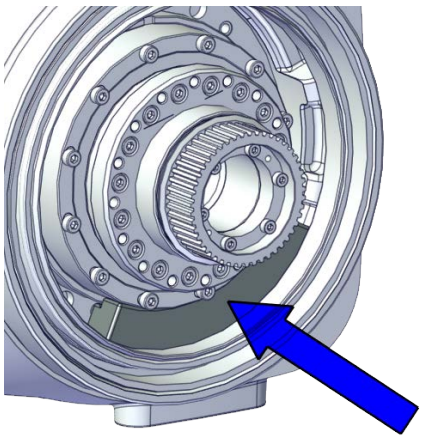
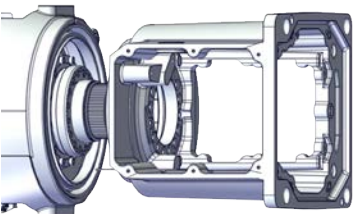
	Action	Note
<p>3</p>	<p>Remove the screws and washers.</p> <p> Tip</p> <p>Three screw holes have no screws fitted in. Take photos of the screw and washer position before removing them, to have as a reference when refitting.</p>  <p>xx1800003068</p>	 <p>xx1800003069</p>
<p>4</p>	<p>Separate the base from the swing.</p> <p> CAUTION</p> <p>The axis-1 mechanical stop is accessible now. Put it aside for later refitting.</p>  <p>xx1800003071</p>	 <p>xx1800003070</p>

Continues on next page

5 Repair

5.4.1 Replacing the base

Continued

Refitting the base

Use these procedures to refit the base.

Checking the radial sealing on the swing (IP67 and Clean Room)

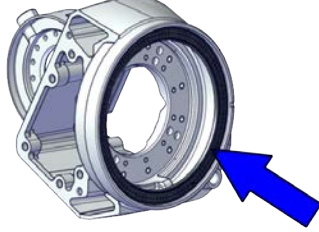
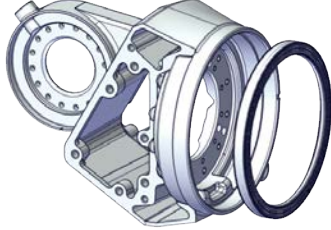
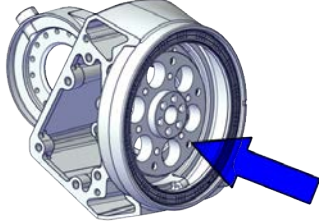
	Action	Note
1	For robots with protection type Clean Room: Clean the joints that have been opened and wipe the parts free from particles with spirit on a lint free.	
2	Check the radial sealing on the swing. Replace if damaged, as described below. In order to replace the radial sealing, both the axis-1 mechanical stop and the axis-1 gearbox must be removed from the swing, if not already removed.	 xx1900002200
3	Apply a little grease to the new sealing when replacing the radial sealing and wipe clean after the replacement.	Grease: 3HAC029132-001
4	Place the new sealing in its groove in the swing.	 xx1900002154
5	Place the small circular plate of the radial sealing fitting tool in and against the swing.	Axis-1 radial sealing assembly tool, included in the radial sealing assembly tool set 3HAC074609-001.  xx1900002155

Continues on next page

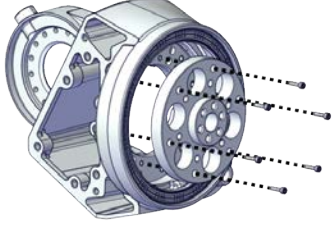
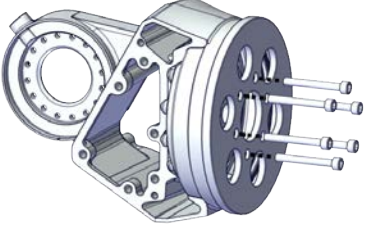
	Action	Note
6	Secure the small circular plate with screws.	 xx2000000305
7	Place the large circular plate of the radial sealing fitting tool against the radial sealing and fix with six M6x50 screws.	 xx1900002156
8	Screw the screws, little by little and evenly, to press the sealing into place.	
9	Remove the assembly tool.	
10	Check that the sealing is undamaged and properly fitted.	

Placing the axis-1 mechanical stop

	Action	Note
1	For robots with protection type Clean Room: Clean the joints that have been opened and wipe the parts free from particles with spirit on a lint free.	
2	Check the axis-1 mechanical stop. Replace if damaged.	Mechanical stop, axis 1: 3HAC061947-001

Continues on next page

5 Repair

5.4.1 Replacing the base

Continued

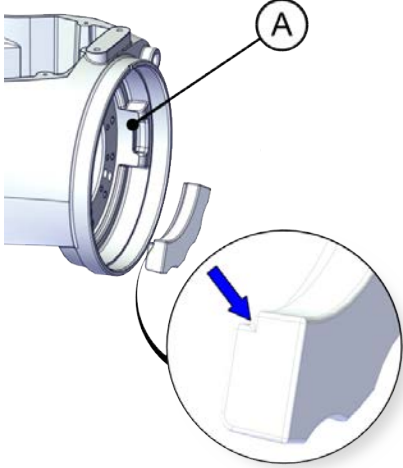
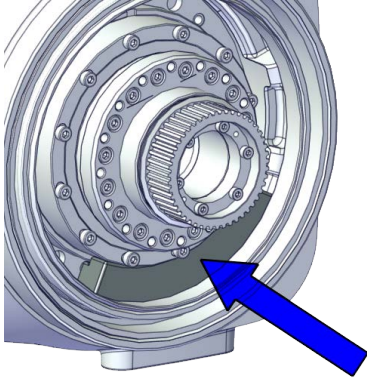
	Action	Note
3	<p>Put the axis-1 mechanical stop in place in the swing.</p> <p> Note</p> <p>The mechanical stop can be placed in any place except the block (A) on the swing. Make sure the mechanical stop step pointed in the figure is facing the swing when putting.</p>  <p>xx1800003619</p>	 <p>xx1800003071</p>

Refitting the base to the swing

	Action	Note
1	<p>For robots with protection type Clean Room: Clean the joints that have been opened and wipe the parts free from particles with spirit on a lint free.</p>	

Continues on next page

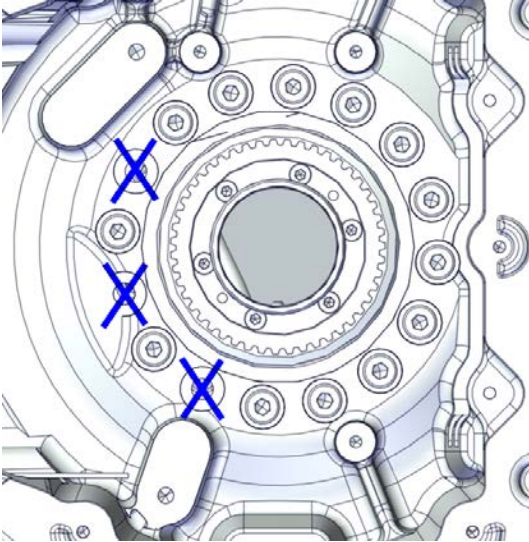
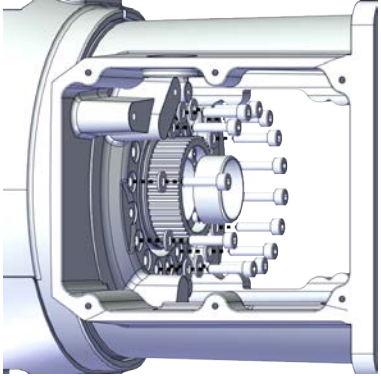
	Action	Note
2	<p>Refit the base to the swing.</p> <p> Note</p> <p>Pay attention to the screw and washer location.</p>  <p>xx1800003068</p>	<p>Screw: M4x16 12.9 Lafre 2C2B/FC6.9 (13 pcs) Tightening torque: 4.4 Nm</p>  <p>xx1800003069</p>

Refitting the brake release button

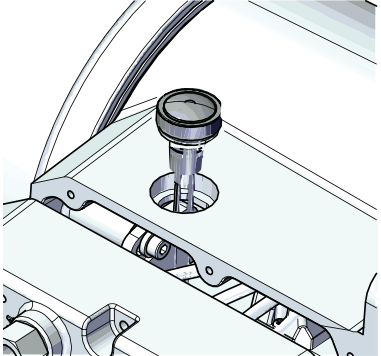
	Action	Note
1	<p>For robots with protection type Clean Room: Clean the joints that have been opened and wipe the parts free from particles with spirit on a lint free.</p>	
2	<p>Refit the brake release button.</p> <p> Note</p> <p>Do not reconnect the connector yet. Do not tighten the button yet.</p>	<p>brake release button assembly tool, included in the special toolkit 3HAC071022-001</p>  <p>xx1800003040</p>

Continues on next page

5 Repair



5.4.1 Replacing the base

Continued

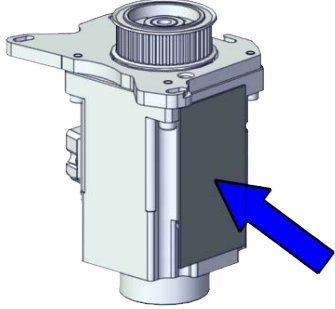
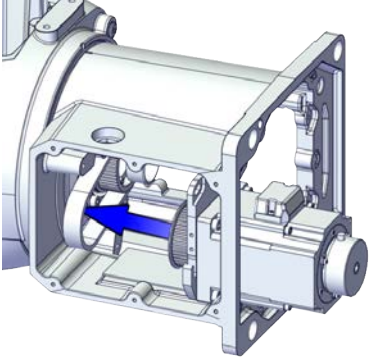
Refitting the axis-1 motor

	Action	Note
1	For robots with protection type Clean Room: Clean the joints that have been opened and wipe the parts free from particles with spirit on a lint free.	
2	Check that: <ul style="list-style-type: none">• all assembly surfaces are clean and without damages• the motor is clean and undamaged.	
3	Check the cooling pad. Replace if damaged.	Cooling pad for axis-1 and -2 motors: 3HAC071020-001  xx1800003602
4	Install the timing belt to the motor pulley and verify that the belt runs correctly in the groove of the pulley.	 xx1800003085

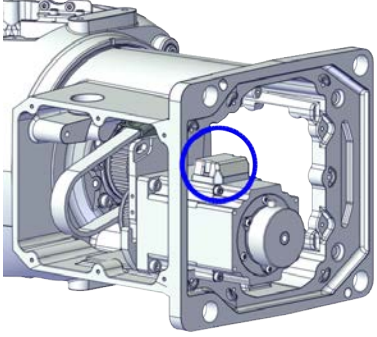
Continues on next page

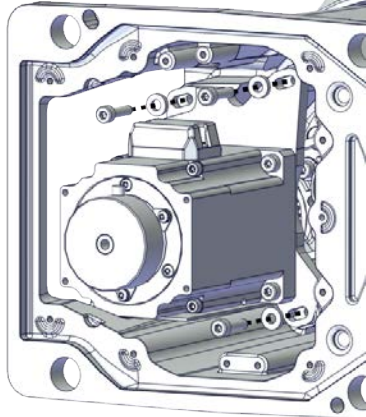
	Action	Note
5	<p>Orient the motor correctly and fit it into the base. At the same time, install the timing belt to the gearbox pulley and verify that the belt runs correctly in the groove of the pulley.</p>	<p>Motor orientation: orient the motor according to the figure below, in regard to the encircled motor connector.</p>  <p>xx1800003072</p>
6	<p>Refit the screws and washers.</p> <p> Note Do not tighten the screws yet.</p>	<p>Screw: M4x16 12.9 Lafre 2C2B/FC6.9 (3 pcs) Washer, 3HAC063985-001 (3 pcs)</p>  <p>xx1800003065</p>

Adjusting the axis-1 timing belt tension

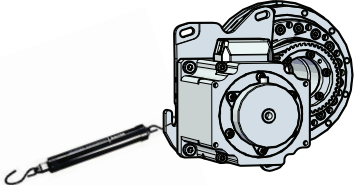

	Action	Note
1	<p>For robots with protection type Clean Room: Clean the joints that have been opened and wipe the parts free from particles with spirit on a lint free.</p>	
2	<p>Use a handheld dynamometer hooking to the motor.</p>	 <p>xx1900000040</p>

Continues on next page

5 Repair

5.4.1 Replacing the base

Continued

	Action	Note
3	<p>Pull the dynamometer to make the tension falling in the allowed force range.</p> <p> Note</p> <p>During the measurement, make sure that all interferences that may affect the force are removed. Pay attention to the force application direction.</p>	<p>Used belt: 58.24-63.56 N New belt:83.2-90.8 N (for reference only)</p>  <p>xx190000041</p>
4	Secure the motor with the screws.	Tightening torque: 3 Nm

Securing the brake release button

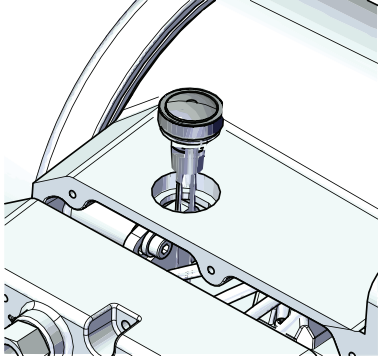



	Action	Note
1	For robots with protection type Clean Room: Clean the joints that have been opened and wipe the parts free from particles with spirit on a lint free.	
2	Tighten the brake release button using the tool.	<p>brake release button assembly tool, included in the special toolkit 3HAC071022-001</p>  <p>xx1800003040</p>

Refitting the lower cable package through the axis-1 gearbox

Notice that the procedure differs depending on if the connector interface is located either at the rear or at the bottom of the base.

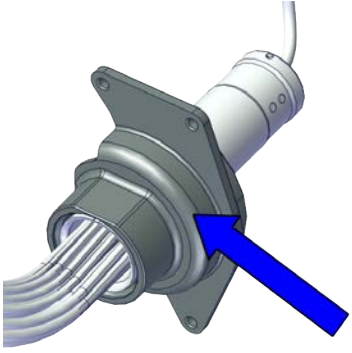
	Action	Note
1	For robots with protection type Clean Room: Clean the joints that have been opened and wipe the parts free from particles with spirit on a lint free.	

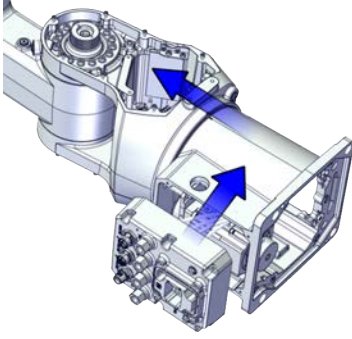
Continues on next page





	Action	Note
2	Refit the pulley cover to the lower cable package.	 <p>xx1800003046</p>
3	<p>Valid for cabling with rear interface Insert the cable package in the base and up through the axis-1 gearbox, through the rear.</p> <p> Tip Wrap the connectors with the masking tape.</p> <p> CAUTION Make sure that no cables or hoses are twisted or strained. Reroute if necessary.</p>	 <p>xx1800003047</p> <p>Cable protection tube orientation: use the encircled notch on the cable protection tube as a reference when inserting the cable package, which should be at the opposite direction to the locking screw hole on the gearbox.</p>  <p>xx1800003048</p>

Continues on next page

5 Repair

5.4.1 Replacing the base

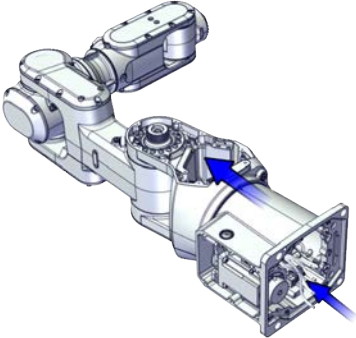
Continued

	Action	Note
4	<p>Valid for cabling with bottom interface (option 3309-1)</p> <p>Insert the cable package in the base and up through the axis-1 gearbox, through the bottom.</p> <p> Tip</p> <p>Wrap the connectors with the masking tape.</p> <p> CAUTION</p> <p>Make sure that no cables or hoses are twisted or strained. Reroute if necessary.</p>	 <p>xx1800003060</p> <p>Cable protection tube orientation: use the encircled notch on the cable protection tube as a reference when inserting the cable package, which should be at the opposite direction to the locking screw hole on the gearbox.</p>  <p>xx1800003048</p>

Securing the lower cable package to the axis-1 gearbox

	Action	Note
1	<p>For robots with protection type Clean Room: Clean the joints that have been opened and wipe the parts free from particles with spirit on a lint free.</p>	

Continues on next page

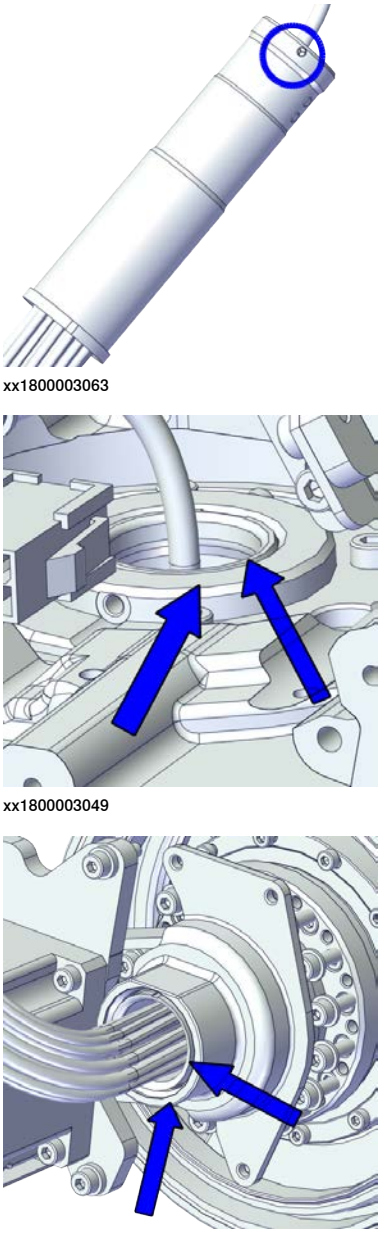

	Action	Note
2	<p>Make sure that:</p> <ul style="list-style-type: none"> • The hole on the cable protection tube is aligned with the locking screw hole on the gearbox. • The cable protection tube surface is completely parallel with the pulley cover at one side and with the flange at the other side. 	 <p>xx1800003063</p> <p>xx1800003049</p> <p>xx1800003050</p>

Continues on next page

5 Repair

5.4.1 Replacing the base

Continued

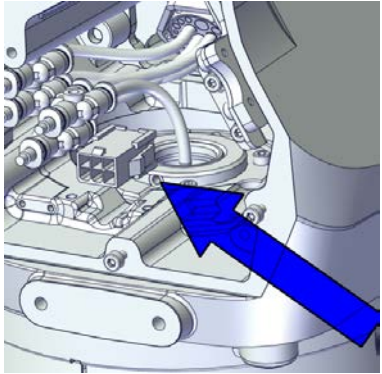
	Action	Note
3	<p>Apply a little Loctite 243 to the locking screw and refit the locking screw.</p> <p> Note</p> <p>Make sure the locking screw header is parallel with flange surface.</p> <p> Note</p> <p>If there is locking liquid residues on the screw or screw hole, please clean it before refitting. Remove residual locking liquid after refitting.</p>	<p>Screw: M3x8 (1 pcs) Tightening torque: 0.4 Nm</p>  <p>xx1800003032</p>

Refitting the pulley cover

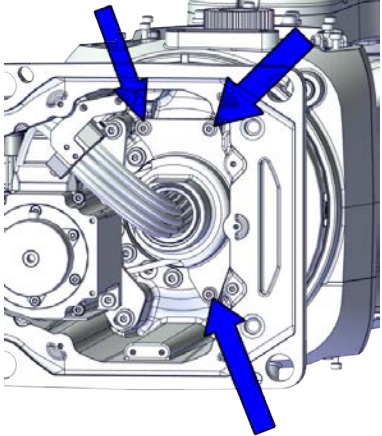
	Action	Note
1	<p>For robots with protection type Clean Room: Clean the joints that have been opened and wipe the parts free from particles with spirit on a lint free.</p>	
2	<p>Refit the puller cover.</p>	<p>Screw: M3x8 12.9 Lafre 2C2B/FC6.9 (3 pcs) Tightening torque: 1.2 Nm</p>  <p>xx1800003043</p>



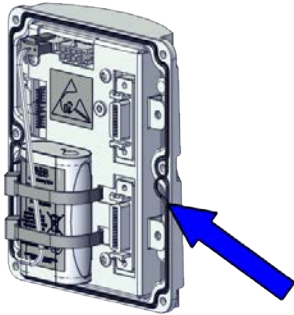

Checking the SMB cover gasket

	Action	Note
1	<p>For robots with protection type Clean Room: Clean the joints that have been opened and wipe the parts free from particles with spirit on a lint free.</p>	

Continues on next page

	Action	Note
2	<p>For robots with protection class IP67 (option 3350-670) For robots with protection type Clean Room (option 3351-4) Check the gasket. Replace if damaged.</p>	 <p>xx1900002186</p>

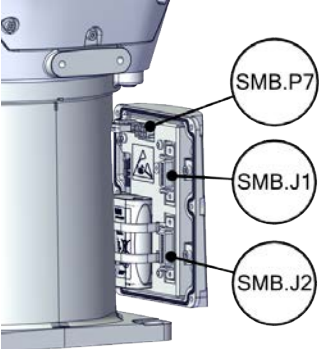
Reconnecting the SMB connectors

	Action	Note
1	 <p>ELECTROSTATIC DISCHARGE (ESD)</p> <p>The unit is sensitive to ESD. Before handling the unit read the safety information in section The unit is sensitive to ESD on page 49.</p>	
2	<p>For robots with protection type Clean Room Clean the joints that have been opened and wipe the parts free from particles with spirit on a lint free.</p>	
3	<p>Reconnect the connectors.</p> <ul style="list-style-type: none"> • SMB.P7 • SMB.J1 • SMB.J2  <p>Tip</p> <p>See the number markings on the connectors for help to find the corresponding connector.</p>	<p>Tightening torque: 0.3 Nm</p>  <p>xx1800002468</p>
4	<p>Route and secure the cabling with cable straps.</p>  <p>CAUTION</p> <p>Correct cable routing is highly important. If the cables are routed and secured incorrectly the cables can be damaged.</p>	

Continues on next page

5 Repair

5.4.1 Replacing the base

Continued

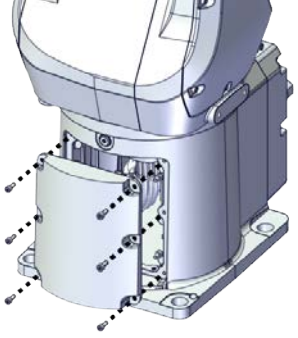
	Action	Note
5	Refit the SMB cover to the base.	<p>Screw: M3x8 12.9 Lafre 2C2B/FC6.9 (6 pcs) Tightening torque: 1.2 Nm</p>  <p>xx1800002467</p>

Securing the lower cable package to the base

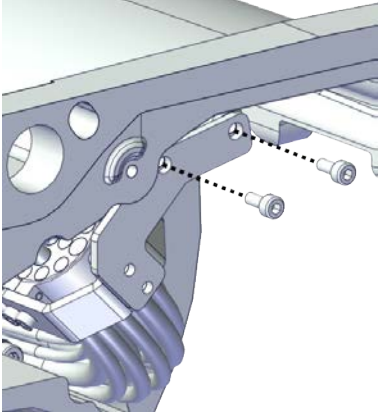
	Action	Note
1	For robots with protection type Clean Room: Clean the joints that have been opened and wipe the parts free from particles with spirit on a lint free.	
2	Refit the cable bracket.	<p>Screw: M2.5x6 12.9 Lafre 2C2B/FC6.9 (2 pcs) Tightening torque: 0.6 Nm</p>  <p>xx1800003042</p>

Reconnecting the brake release cabling and axis-1 motor connectors

	Action	Note
1	For robots with protection type Clean Room: Clean the joints that have been opened and wipe the parts free from particles with spirit on a lint free.	

Continues on next page

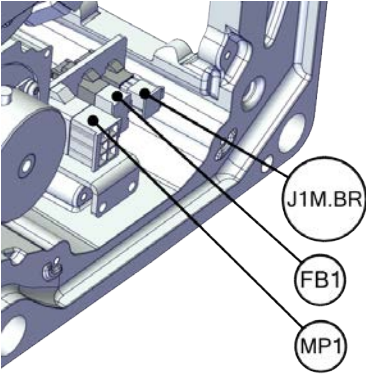
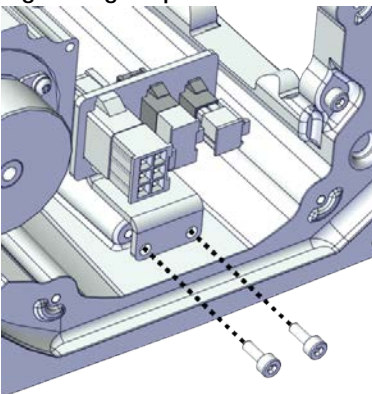
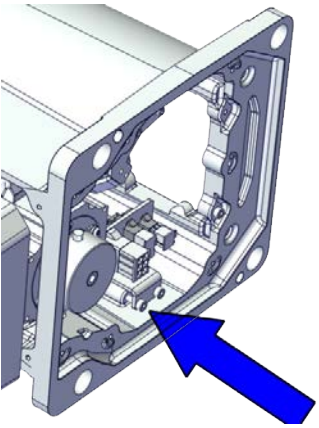
	Action	Note
2	<p>Reconnect the connectors.</p> <ul style="list-style-type: none"> • J1M.BR • MP1 • FB1 <p> Tip</p> <p>See the number markings on the connectors for help to find the corresponding connector.</p>	 <p>xx1800003054</p>
3	<p>Reconnect the floor cable together with the connector plate.</p>	<p>Screw: M3x8 12.9 Lafre 2C2B/FC6.9 (2 pcs) Tightening torque: 0.8 Nm</p>  <p>xx1800003037</p>  <p>xx1800003036</p>

Continues on next page



5 Repair

5.4.1 Replacing the base

Continued

Refitting the base cover

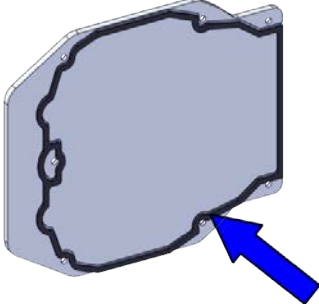
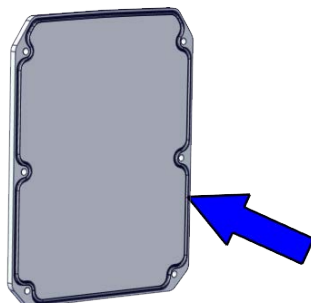
Notice that the procedure differs depending on if the connector interface is located either at the rear or at the bottom of the base.

	Action	Note
1	For robots with protection type Clean Room: Clean the joints that have been opened and wipe the parts free from particles with spirit on a lint free.	
2	For robots with protection class IP67 (option 3350-670) For robots with protection type Clean Room (option 3351-4) Check the gasket. Replace if damaged.	<p>Valid for cabling with rear interface Gasket for base bottom: 3HAC065345-001</p>  <p>xx1900002184</p> <p>Valid for cabling with bottom interface (option 3309-1) Gasket for base rear: 3HAC065350-001</p>  <p>xx1900002189</p>
3	Apply grease to the cable package, cover all moving area of the package.	
4	Apply grease to the covers that have contacting area with the cable package.	
5	Route and secure the cabling with cable straps.  CAUTION Correct cable routing is highly important. If the cables are routed and secured incorrectly the cables can be damaged.	

Continues on next page

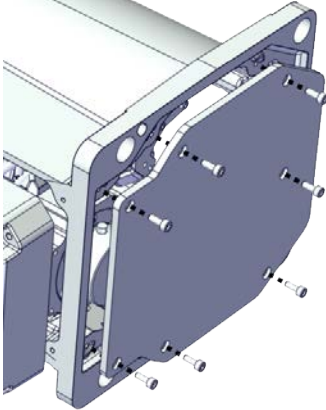
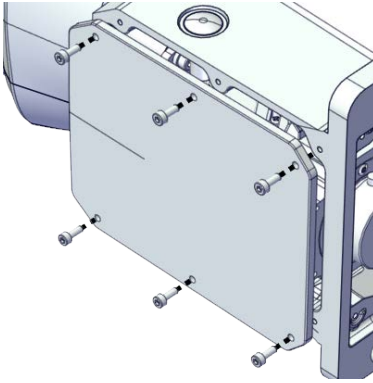
	Action	Note
6	Valid for cabling with rear interface Refit the bottom cover.	Screw: M3x8 Steel 8.8-A2F (7 pcs) Tightening torque: 1.2 Nm  xx1800003035
7	Refit the rear cover.	Screw: M3x8 12.9 Lafre 2C2B/FC6.9 (6 pcs) Tightening torque: 1.2 Nm  xx1800003057

Refitting the connector interface plate



	Action	Note
1	For robots with protection type Clean Room: Clean the joints that have been opened and wipe the parts free from particles with spirit on a lint free.	

Continues on next page

5 Repair

5.4.1 Replacing the base

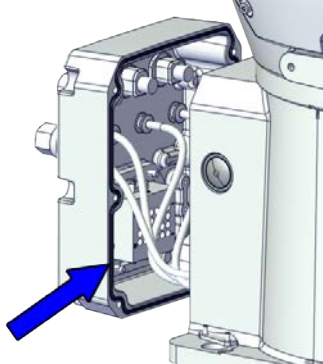
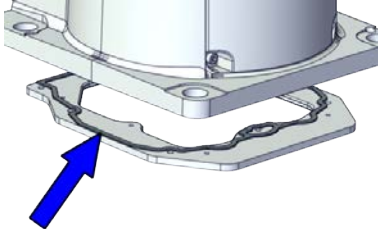
Continued

	Action	Note
2	<p>For robots with protection class IP67 (option 3350-670) For robots with protection type Clean Room (option 3351-4) Check the gasket. Replace if damaged.</p>	<p>Valid for cabling with rear interface Gasket for base rear: 3HAC065350-001</p>  <p>xx1900002183</p> <p>Valid for cabling with bottom interface (option 3309-1) Gasket for base bottom: 3HAC065345-001</p>  <p>xx1900002188</p>
3	<p>Route and secure the cabling with cable straps.</p> <p> CAUTION</p> <p>Correct cable routing is highly important. If the cables are routed and secured incorrectly the cables can be damaged.</p>	

Continues on next page

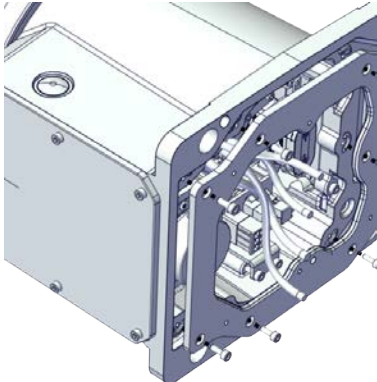
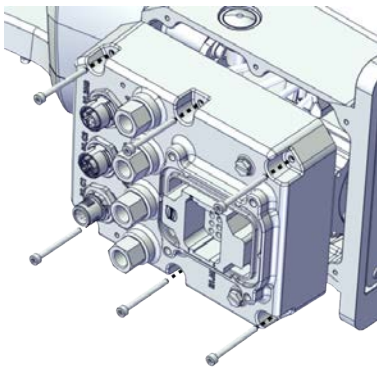
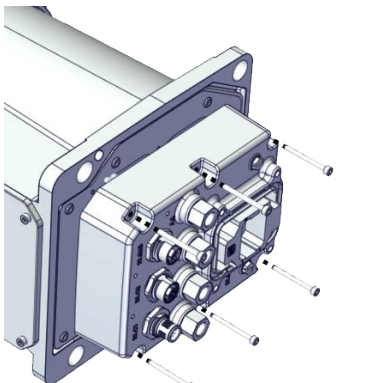
	Action	Note
4	<p>Valid for cabling with bottom interface (option 3309-1)</p> <p>Refit the base adapter.</p>	<p>Screw: M3x8 Steel 8.8-A2F (7 pcs) Tightening torque: 1.2 Nm</p>  <p>xx1800003056</p>
5	<p>Refit the connector interface plate to the base.</p>	<p>Screw: M3x30 12.9 Lafre 2C2B/FC6.9 (6 pcs) Tightening torque: 1.2 Nm</p> <p>Valid for cabling with rear interface</p>  <p>xx1800003034</p> <p>Valid for cabling with bottom interface (option 3309-1)</p>  <p>xx1800003055</p>

Continues on next page

5 Repair



5.4.1 Replacing the base

Continued

Securing the robot to the foundation

	Action	Note
1	For robots with protection type Clean Room: Clean the joints that have been opened and wipe the parts free from particles with spirit on a lint free.	
2	 CAUTION The IRB 1100 robot weighs 21.1 kg and can be lifted by one person.	
3	Raise the robot to standing and secure to the foundation with the attachment screws and washers.	Attachment screws: M12x25 (robot installation directly on foundation), quality: 8.8. Washers: 24 x 13 x 2.5, steel hardness class 200HV. Tightening Torque: 50 Nm±5 Nm.

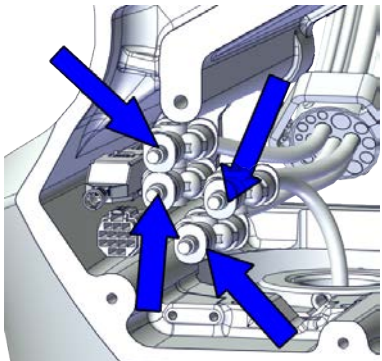
Reconnecting the air hoses, CP/CS cabling and Ethernet cabling (if equipped)

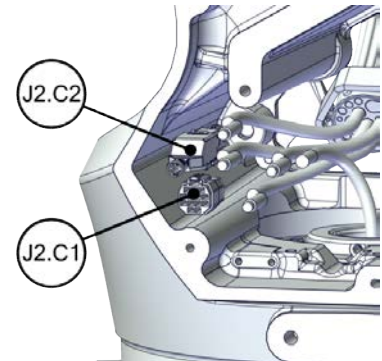
	Action	Note
1	For robots with protection type Clean Room: Clean the joints that have been opened and wipe the parts free from particles with spirit on a lint free.	
2	Reconnect the air hoses in a cross pattern to the Y-shaped connectors.  Tip See the number markings on the air hoses for help to find the corresponding air hoses. The air hoses with the same number connect to the same Y-shaped connector.	 xx1800002500
3	Reconnect the connectors. <ul style="list-style-type: none"> • J2.C1 • J2.C2  Tip See the number markings on the connectors for help to find the corresponding connector.	 xx1800002501

Continues on next page

Securing the cable package to the swing

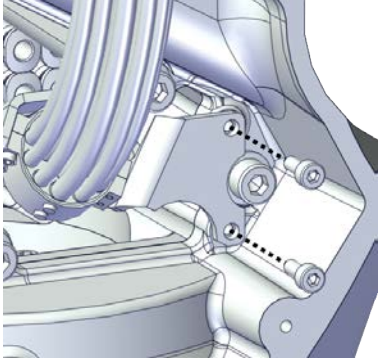
	Action	Note
1	For robots with protection type Clean Room: Clean the joints that have been opened and wipe the parts free from particles with spirit on a lint free.	
2	Refit the cable bracket.	<p>Screw: M3x8 12.9 Lafre 2C2B/FC6.9 (2 pcs) Tightening torque: 0.8 Nm</p>  <p>xx1800002499</p>

Refitting the axis-2 motor

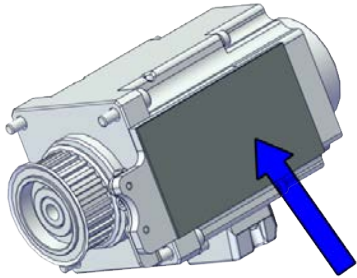



	Action	Note
1	For robots with protection type Clean Room: Clean the joints that have been opened and wipe the parts free from particles with spirit on a lint free.	
2	Check that: <ul style="list-style-type: none"> • all assembly surfaces are clean and without damages • the motor is clean and undamaged. 	
3	Check the cooling pad. Replace if damaged, as shown in the following step.	<p>Cooling pad for axis-1 and -2 motors: 3HAC071020-001</p>  <p>xx1800003603</p>

Continues on next page

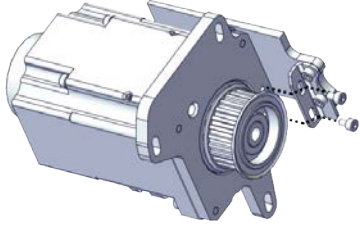

5 Repair

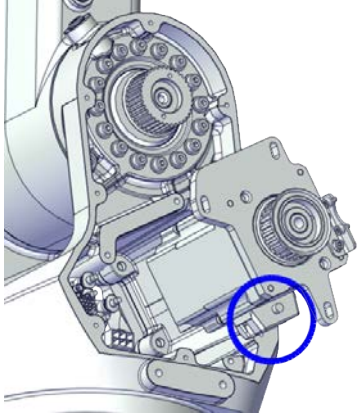
5.4.1 Replacing the base

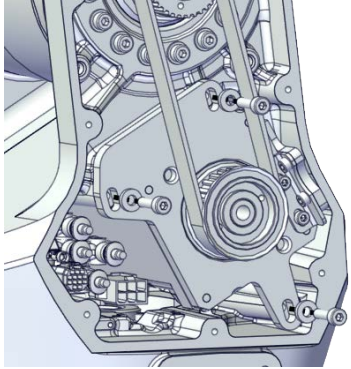
Continued

	Action	Note
4	<p>Remove the screws. Replace with a new cooling pad and then refit the screws.</p>	<p>Screw: M3x5 12.9 Lafre 2C2B/FC6.9 (2 pcs) Tightening torque: 1.2 Nm</p>  <p>xx1800003026</p>
5	<p>Orient the motor correctly and fit it into the swing.</p> <p> Tip</p> <p>Bend the motor signal cable back towards the swing support.</p>	<p>Motor orientation: orient the motor according to the figure below, in regard to the encircled motor connector.</p>  <p>xx1800003027</p>
6	<p>Refit the screws and washers.</p> <p> Note</p> <p>Do not tighten the screws yet.</p>	<p>Screw: M4x16 12.9 Lafre 2C2B/FC6.9 (3 pcs) Washer, 3HAC063985-001 (3 pcs)</p>  <p>xx1800002494</p>

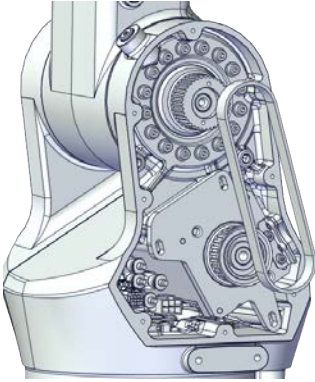
Continues on next page

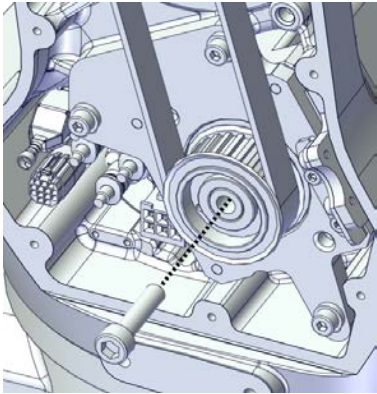
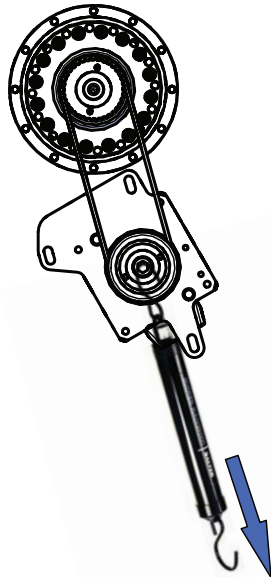

	Action	Note
7	Install the timing belt to the pulleys and verify that the belt runs correctly in the grooves of the pulleys.	 <p>xx1800003028</p>
8	Install an M6x25 or longer adjustment screw to the motor.  Note Do not insert the entire screw to the hole.	 <p>xx1900000010</p>
9	Use a handheld dynamometer hooking to the screw and pull the dynamometer to reach the initial referenced force.	Initial referenced force for used belt: 68.18-75.04 N (for reference only) Initial referenced force for new belt: 97.4-107.2 N  <p>xx1900000029</p>

Continues on next page

5 Repair



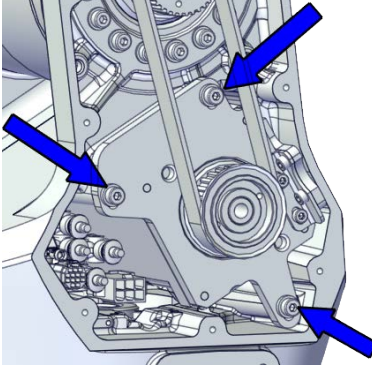
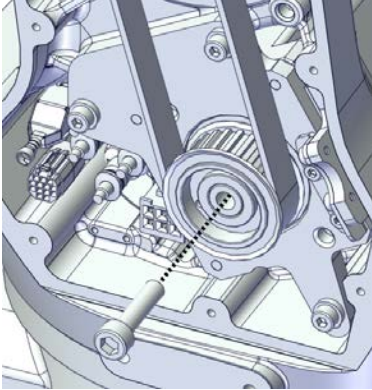

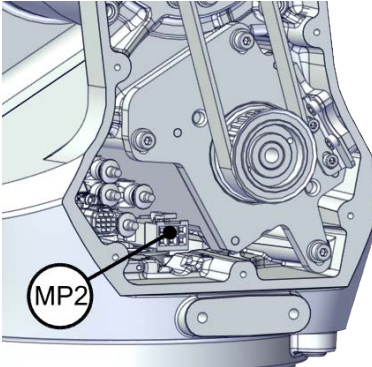
5.4.1 Replacing the base

Continued

	Action	Note
10	Secure the motor with the screws.	<p>Tightening torque: 3.5 Nm</p>  <p>xx1800002493</p>
11	Use a sonic tension meter to measure the timing belt tension.	<p>Used belt: 163-174 Hz New belt: 180-229 Hz (for reference only)</p>
12	If the timing belt tension does not meet the requirement, loosen the motor screws and readjust.	
13	Remove the adjustment screw from the motor.	 <p>xx1900000010</p>
14	<p>Reconnect the connector.</p> <ul style="list-style-type: none"> • MP2 <p> Tip</p> <p>See the number markings on the connectors for help to find the corresponding connector.</p>	 <p>xx1800002495</p>

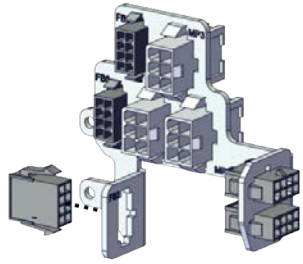
Continues on next page

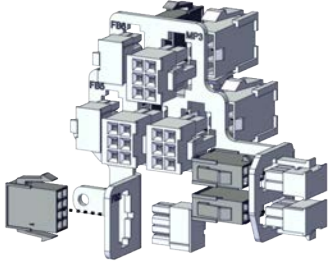
Reconnecting the connectors at the division point

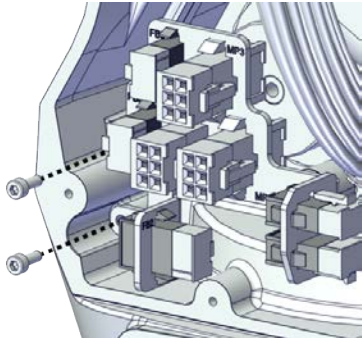
	Action	Note
1	<p>For robots with protection type Clean Room: Clean the joints that have been opened and wipe the parts free from particles with spirit on a lint free.</p>	
2	<p>Insert the female header of the connectors to the connector plate.</p>	 <p>xx1800003029</p>
3	<p>Reconnect the connectors.</p> <ul style="list-style-type: none"> • J2.FB2,3,4,5,6 • J2.MP3,4,5/6 <p> Tip</p> <p>See the number markings on the connectors for help to find the corresponding connector.</p>	 <p>xx1800003030</p>
4	<p>Route and secure the cabling with cable straps.</p> <p> CAUTION</p> <p>Correct cable routing is highly important. If the cables are routed and secured incorrectly the cables can be damaged.</p>	
5	<p>Refit the connector plate.</p>	<p>Screw: M3x8 12.9 Lafre 2C2B/FC6.9 (2 pcs) Tightening torque: 0.8 Nm</p>  <p>xx1800002489</p>

Continues on next page

5 Repair

5.4.1 Replacing the base

Continued

Refitting the swing covers

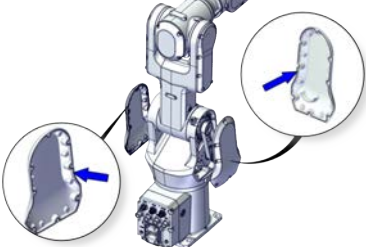
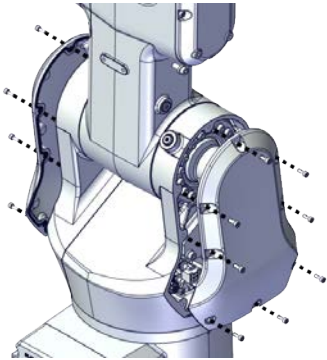
	Action	Note
1	For robots with protection type Clean Room: Clean the joints that have been opened and wipe the parts free from particles with spirit on a lint free.	
2	For robots with protection class IP67 (option 3350-670) For robots with protection type Clean Room (option 3351-4) Check the gaskets. Replace if damaged.	 xx1900002175
3	Apply grease to the cable package, cover all moving area of the package.	
4	Apply grease to the covers that have contacting area with the cable package.	
5	Refit the covers. <ul style="list-style-type: none"> • Swing cover • Swing support cover 	Screw: M3x8 12.9 Lafre 2C2B/FC6.9 Tightening torque: 1.2 Nm  xx1800003607

Concluding procedure

	Action	Note
1	For robots with protection type Clean Room: Clean and paint the joints that have been opened. See Cut the paint or surface on the robot before replacing parts on page 124 .  Note After all repair work, wipe the Clean Room robot free from particles with spirit on a lint free cloth.	
2	Recalibrate the robot.	Calibration is detailed in section Calibration on page 685 .

Continues on next page

	Action	Note
3	 DANGER Make sure all safety requirements are met when performing the first test run. See Test run after installation, maintenance, or repair on page 91 .	

5 Repair

5.4.2 Replacing the swing

5.4.2 Replacing the swing

Location of the swing

The swing is located as shown in the figure.

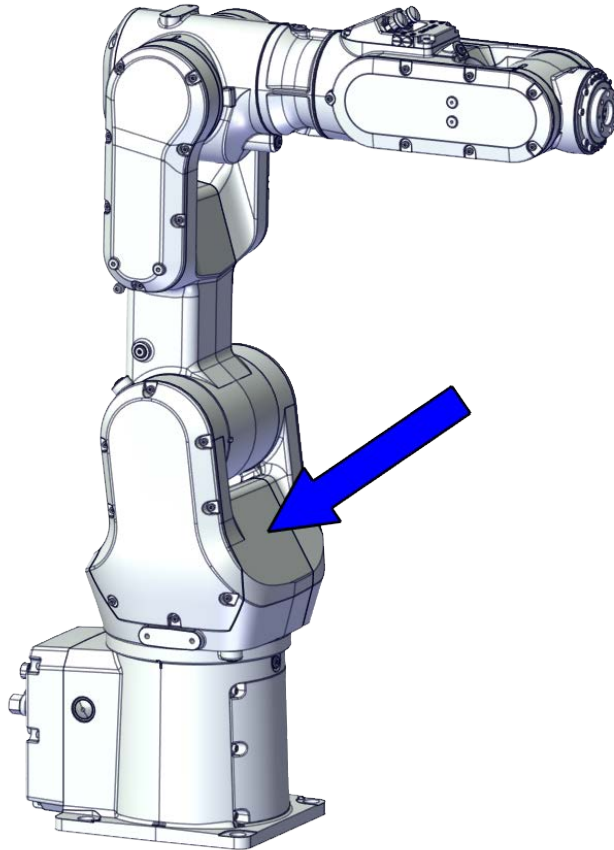

xx1800002473

Required spare parts



Note

The spare part numbers that are listed in the table can be out of date. See the latest spare parts of the IRB 1100 via myABB Business Portal, www.abb.com/myABB.

Spare part	Article number	Note
Lower cable harness, basic	3HAC075521-001	Used with protection classes IP40 and IP67.
Lower cable harness, basic, Clean Room	3HAC075514-001	Used with protection type Clean Room.
Lower cable harness (CP/CS and air hose, without Ethernet)	3HAC075522-001	Used with protection classes IP40 and IP67.

Continues on next page

Spare part	Article number	Note
Lower cable harness, Clean Room (CP/CS and air hose, without Ethernet)	3HAC075515-001	Used with protection type Clean Room.
Lower cable harness (CP/CS and air hose, with Ethernet)	3HAC075523-001	Used with protection classes IP40 and IP67.
Lower cable harness, Clean Room (CP/CS and air hose, with Ethernet)	3HAC075581-001	Used with protection type Clean Room.
Swing	3HAC069050-001	
Swing, Clean Room	3HAC075497-001	Used with protection type Clean Room.
Swing support	3HAC069039-001	
Swing support, Clean Room	3HAC075499-001	Used with protection type Clean Room.
Base	3HAC069048-001	
Base with sealing ring	3HAC074270-001	Used with protection class IP67.
Base with sealing ring, Clean Room	3HAC075488-001	Used with protection type Clean Room.
Axis-1 radial sealing	3HAC070148-005	Used with protection class IP67 and protection type Clean Room. Replace if damaged.
Axis-2 radial sealing	3HAB3701-70	Used with protection class IP67 and protection type Clean Room. Replace if damaged.
Gear unit with pulley, axis 1	3HAC069062-001	
Motor with flange, axis 1	3HAC083589-001	
Timing belt, axis 1	3HAC061934-001	
Motor with flange, axis 2	3HAC083588-001	.
Timing belt, axis 2	3HAC061935-001	
Mechanical stop, axis 1	3HAC061947-001	Replace if damaged.
Base bottom cover	3HAC060463-001	Standard configuration, used for robots with rear connector interface.
Base rear cover	3HAC070312-001	Used for robots with bottom connector interface.
Base rear cover, Clean Room	3HAC075513-001	Used for robots with bottom connector interface. Used with protection type Clean Room.
Base adapter	3HAC070313-001	Used for robots with bottom connector interface.
Base adapter, Clean Room	3HAC075793-001	Used for robots with bottom connector interface. Used with protection type Clean Room.
Swing cover	3HAC069051-001	

Continues on next page

5 Repair

5.4.2 Replacing the swing

Continued

Spare part	Article number	Note
Swing cover, Clean Room	3HAC075498-001	Used with protection type Clean Room.
Swing support cover	3HAC069052-001	
Swing support cover, Clean Room	3HAC075500-001	Used with protection type Clean Room.
Gasket for base bottom	3HAC065345-001	Used with protection class IP67 and protection type Clean Room. Replace if damaged.
Gasket for base rear	3HAC065350-001	Used with protection class IP67 and protection type Clean Room. Replace if damaged.
Gasket for swing cover	3HAC061959-003	Used with protection class IP67 and protection type Clean Room. Replace if damaged.
Gasket for swing support cover	3HAC065317-001	Used with protection class IP67 and protection type Clean Room. Replace if damaged.
Gasket for SMB cover	3HAC065344-001	Used with protection class IP67 and protection type Clean Room. Replace if damaged.
Cooling pad for axis-1 and -2 motors	3HAC071020-001	Cooling pads are wear parts. One cooling pad sheet contains 6 pieces of small pad. Replace if damaged with one piece each time.
Washer	3HAC063985-001	9x4.3x1, Steel

Required tools and equipment

Equipment	Article number	Note
Standard toolkit	-	Content is defined in section Standard toolkit on page 733 .
Calibration tool box, Axis Calibration	3HAC074119-001	Delivered as a set of calibration tools. Required if Axis Calibration is the valid calibration method for the robot. The tool box also includes a unique calibration pin for IRB 1100 to be fitted to the tool flange during calibration of axis 6.
24 VDC power supply	-	Used to release the motor brakes.
Sonic tension meter	-	Used for measuring the timing belt tension.
Dynamometer	-	Used for measuring the timing belt tension.
brake release button assembly tool	-	Included in the special toolkit 3HAC071022-001. Used to remove and refit the brake release button.

Continues on next page

Required consumables

Consumable	Article number	Note
Cable straps	-	
Grease	3HAC029132-001	FM 222
Grease	-	Castrol Molub. Alloy 777-1 NG Used to lubricate bearings on the swing support and lower arm support.
Locking liquid	-	Loctite 2400 (or equivalent Loctite 243)
Sealing compound	3HAC026759-002	Sikaflex 521 FC For robots with protection type Clean Room.

Deciding calibration routine

Decide which calibration routine to be used, based on the information in the table. Depending on which routine is chosen, action might be required prior to beginning the repair work of the robot, see the table.

	Action	Note
1	Decide which calibration routine to use for calibrating the robot. <ul style="list-style-type: none"> Reference calibration. External cable packages (DressPack) and tools can stay fitted on the robot. Fine calibration. All external cable packages (DressPack) and tools must be removed from the robot. 	 Note Calibrating axis 6 always requires tools to be removed from the mounting flange (also for reference calibration) since the mounting flange is used for installation of the calibration tool.
	If the robot is to be calibrated with reference calibration: Find previous reference values for the axis or create new reference values. These values are to be used after the repair procedure is completed, for calibration of the robot. If no previous reference values exist, and no new reference values can be created, then reference calibration is not possible.	Follow the instructions given in the reference calibration routine on the FlexPendant to create reference values. Creating new values requires possibility to move the robot. Read more about reference calibration for Axis Calibration in Reference calibration routine on page 696 .
	If the robot is to be calibrated with fine calibration: Remove all external cable packages (DressPack) and tools from the robot.	

Removing the swing

Use these procedures to remove the swing.

Preparations before removing the swing



	Action	Note
1	Decide which calibration routine to use, and take actions accordingly prior to beginning the repair procedure.	

Continues on next page

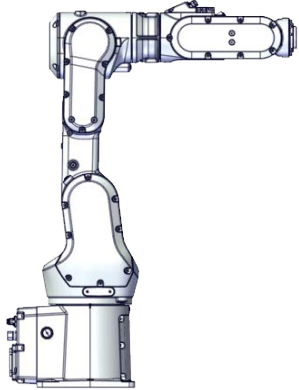

5 Repair

5.4.2 Replacing the swing





Continued

	Action	Note
2	Jog all axes to zero position.	 <p>xx1800003288</p>
3	 <p>DANGER</p> <p>Turn off all:</p> <ul style="list-style-type: none"> • electric power supply • hydraulic pressure supply • air pressure supply <p>to the robot, before entering the safeguarded space.</p>	
4	 <p>CAUTION</p> <p>For robots with protection type Clean Room Always cut the paint with a knife and grind the paint edge when disassembling parts of the robot! See <i>Cut the paint or surface on the robot before replacing parts on page 124.</i></p>	

Removing the axis-2 motor

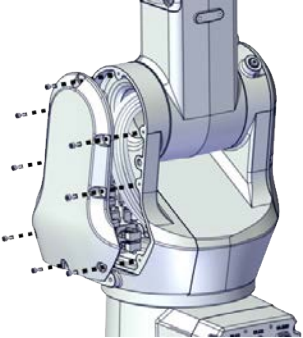
	Action	Note
1	 <p>DANGER</p> <p>Make sure that all supplies for electrical power, hydraulic pressure, and air pressure are turned off.</p>	
2	 <p>CAUTION</p> <p>For robots with protection type Clean Room Always cut the paint with a knife and grind the paint edge when disassembling parts of the robot! See <i>Cut the paint or surface on the robot before replacing parts on page 124.</i></p>	

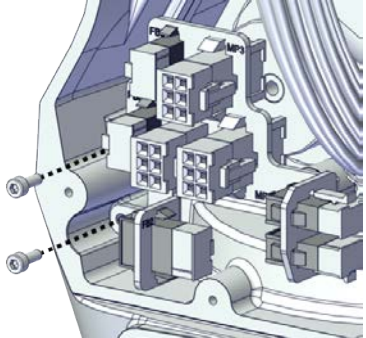
Continues on next page

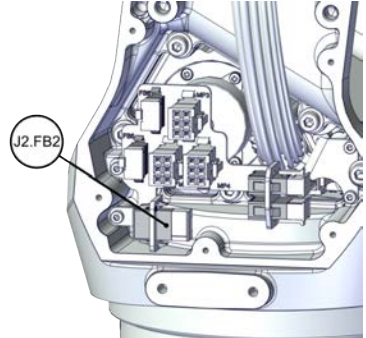

	Action	Note
3	<p> CAUTION</p> <p>Removing motors will release axes. This means the axes can fall down. Make sure axes are well supported before removing motors.</p>	
4	<p>Remove the swing support cover.</p>	 <p>xx1800002488</p>
5	<p>Remove the connector plate.</p> <p> CAUTION</p> <p>Be aware of the cablings that are attached to the connector plate! The connector plate cannot be removed completely until the connectors are removed from the plate.</p>	 <p>xx1800002489</p>
6	<p>Disconnect the connector.</p> <ul style="list-style-type: none"> • J2.FB2 <p> Tip</p> <p>Take photos of the connector and cable position before disconnecting them, to have as a reference when reconnecting.</p>	 <p>xx1800002490</p>

Continues on next page

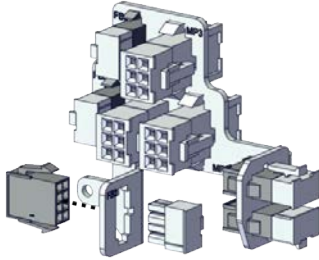
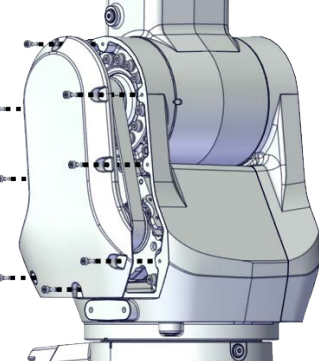

5 Repair

5.4.2 Replacing the swing

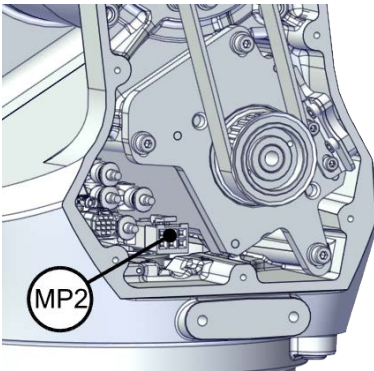
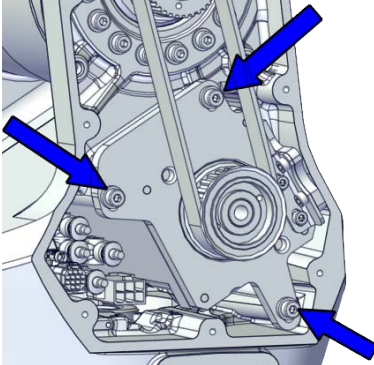
Continued

	Action	Note
7	Snap loose and remove the female head of the connector from the connector plate.	 xx1800002491
8	Remove the swing cover.	 xx1800002492
9	Disconnect the connector. <ul style="list-style-type: none">• MP2  Tip Take photos of the connector and cable position before disconnecting them, to have as a reference when reconnecting.	 xx1800002495
10	Loosen the screws and move the motor slightly to slacken the timing belt.	 xx1800002493

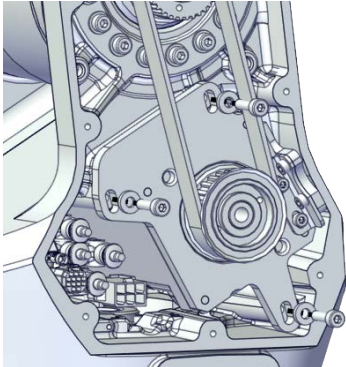
Continues on next page

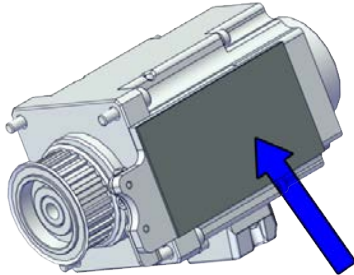
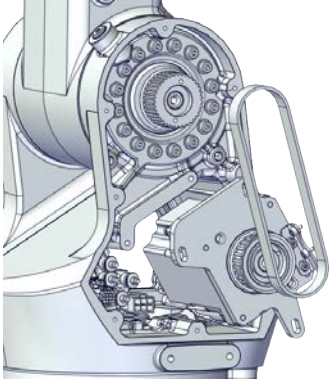
	Action	Note
11	Remove the screws and washers.	 <p>xx1800002494</p>
12	<p>Carefully lift out the motor.</p> <p> CAUTION</p> <p>A cooling pad is attached to the motor, which may stick to the casting. Always use a plastic sheet with caution to remove the pad from the casting. Pay attention not to scratch the casting or damage the pad.</p> <p> CAUTION</p> <p>Be aware of the motor cabling. The motor cannot be removed completely until the connector is disconnected, as shown in following step.</p>	<p>Cooling pad location</p>  <p>xx1800003603</p>
13	Remove the timing belt from its groove on the motor.	 <p>xx1800002496</p>

Loosening the cable package from axis-1 gearbox

	Action	Note
1	<p> DANGER</p> <p>Make sure that all supplies for electrical power, hydraulic pressure, and air pressure are turned off.</p>	

Continues on next page



5 Repair

5.4.2 Replacing the swing

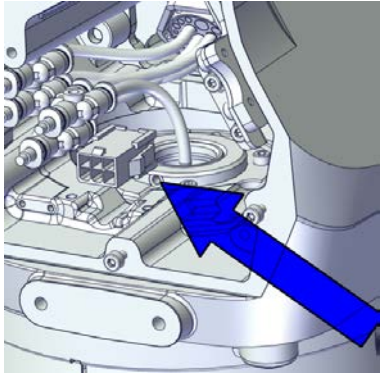
Continued

	Action	Note
2	 CAUTION For robots with protection type Clean Room Always cut the paint with a knife and grind the paint edge when disassembling parts of the robot! See Cut the paint or surface on the robot before replacing parts on page 124 .	
3	Access the cable package locking screw on the axis-1 gearbox from the swing and then loosen the locking screw.	 xx1800003032
4	Remove the locking screw.	

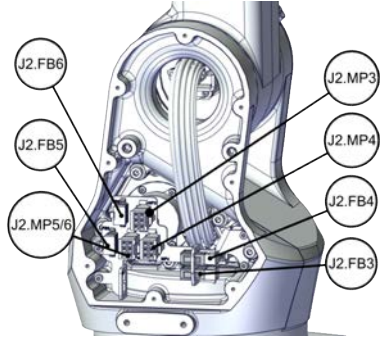

Disconnecting the connectors at the division point

	Action	Note
1	 DANGER Make sure that all supplies for electrical power, hydraulic pressure, and air pressure are turned off.	
2	 CAUTION For robots with protection type Clean Room Always cut the paint with a knife and grind the paint edge when disassembling parts of the robot! See Cut the paint or surface on the robot before replacing parts on page 124 .	
3	Disconnect the connectors. <ul style="list-style-type: none"> • J2.FB3,4,5,6 • J2.MP3,4,5/6  Tip Take photos of the connector and cable position before disconnecting them, to have as a reference when reconnecting.	 xx1800002497

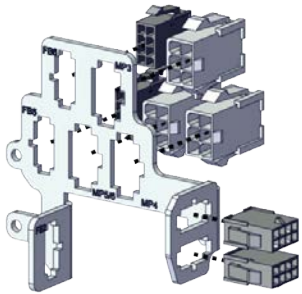
Continues on next page

	Action	Note
4	Snap loose and remove the female head of the connectors from the connector plate.	 <p>xx1800002498</p>

Separating the cable package from the swing

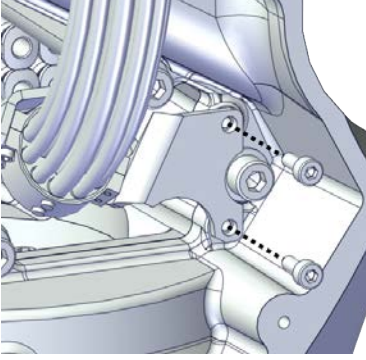
	Action	Note
1	 <p>DANGER</p> <p>Make sure that all supplies for electrical power, hydraulic pressure, and air pressure are turned off.</p>	
2	 <p>CAUTION</p> <p>For robots with protection type Clean Room Always cut the paint with a knife and grind the paint edge when disassembling parts of the robot! See Cut the paint or surface on the robot before replacing parts on page 124.</p>	
3	Remove the cable bracket.	 <p>xx1800002499</p>

Disconnecting the air hoses, CP/CS cabling and Ethernet cabling (if equipped)



	Action	Note
1	 <p>DANGER</p> <p>Make sure that all supplies for electrical power, hydraulic pressure, and air pressure are turned off.</p>	

Continues on next page

5 Repair



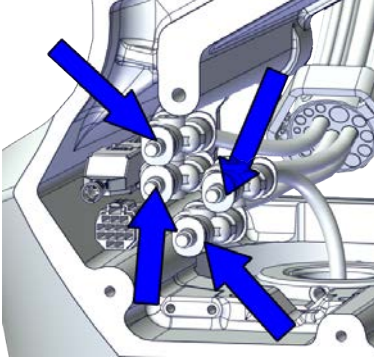

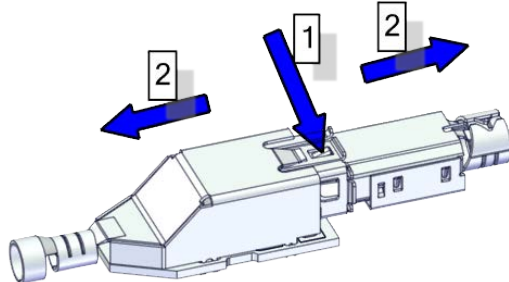
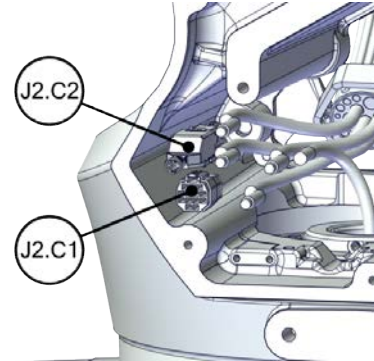
5.4.2 Replacing the swing

Continued

	Action	Note
2	<p> CAUTION</p> <p>For robots with protection type Clean Room Always cut the paint with a knife and grind the paint edge when disassembling parts of the robot! See <i>Cut the paint or surface on the robot before replacing parts on page 124.</i></p>	
3	Disconnect the air hoses from the Y-shaped connectors.	 <p>xx1800002500</p>
4	<p>Disconnect the connectors.</p> <ul style="list-style-type: none">• J2.C1• J2.C2 <p> Tip</p> <p>Take photos of the connector and cable position before disconnecting them, to have as a reference when reconnecting.</p> <p> Tip</p> <p>The connector clip has to be pressed (1) and pushed forward (2) to separate the J2.C2 (for Ethernet cabling).</p>  <p>xx1800002943</p>	 <p>xx1800002501</p>

Continues on next page

Putting the robot on its side

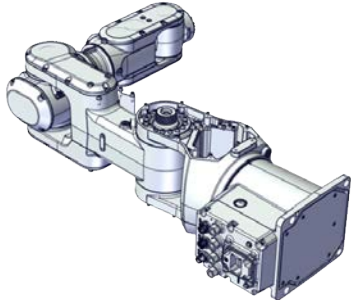
	Action	Note
1	 DANGER Make sure that all supplies for electrical power, hydraulic pressure, and air pressure are turned off.	
2	 CAUTION For robots with protection type Clean Room Always cut the paint with a knife and grind the paint edge when disassembling parts of the robot! See Cut the paint or surface on the robot before replacing parts on page 124 .	
3	 CAUTION The IRB 1100 robot weighs 21.1 kg and can be lifted by one person.	
4	 WARNING The robot is likely to be mechanically unstable if not secured to the foundation.	
5	Loosen the robot from the foundation by removing the foundation attachment screws and put the robot on its side.	 xx1800003033

Disconnecting the SMB connectors







	Action	Note
1	 DANGER Make sure that all supplies for electrical power, hydraulic pressure, and air pressure are turned off.	

Continues on next page

5 Repair

5.4.2 Replacing the swing

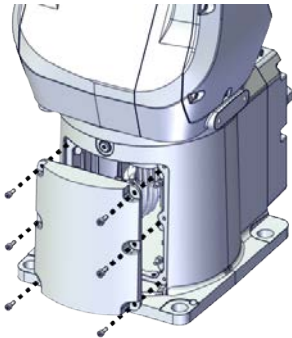

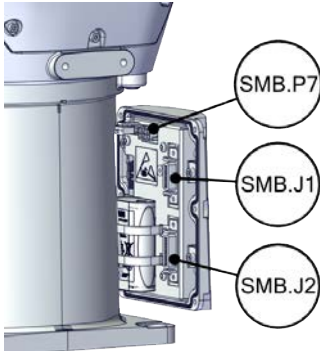
Continued

	Action	Note
2	 ELECTROSTATIC DISCHARGE (ESD) The unit is sensitive to ESD. Before handling the unit read the safety information in section The unit is sensitive to ESD on page 49 .	
3	 CAUTION For robots with protection type Clean Room Always cut the paint with a knife and grind the paint edge when disassembling parts of the robot! See Cut the paint or surface on the robot before replacing parts on page 124 .	
4	Remove the SMB cover attachment screws and carefully open the cover.  CAUTION Clean cover from metal residues before opening. Metal residues can cause shortage on the boards which can result in hazardous failures.  CAUTION There are cabling attached to the cover. The cover cannot be removed completely until the connectors are removed.	 <small>xx1800002467</small>
5	Disconnect the connectors. <ul style="list-style-type: none"> • SMB.P7 • SMB.J1 • SMB.J2  Tip Take photos of the connector and cable position before disconnecting them, to have as a reference when reconnecting.	 <small>xx1800002468</small>
6	Remove the SMB cover completely from the base.	

Opening the connector interface plate

	Action	Note
1	 DANGER Make sure that all supplies for electrical power, hydraulic pressure, and air pressure are turned off.	

Continues on next page

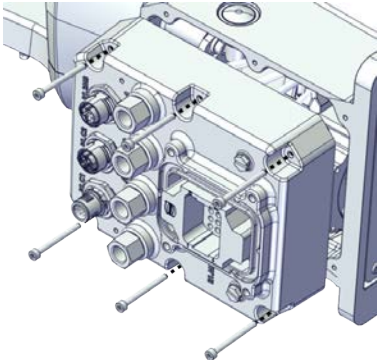
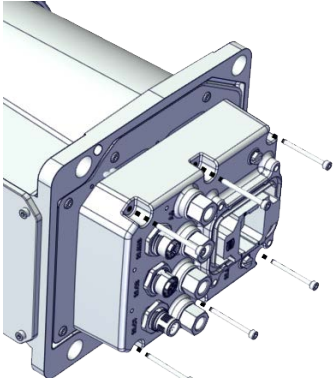
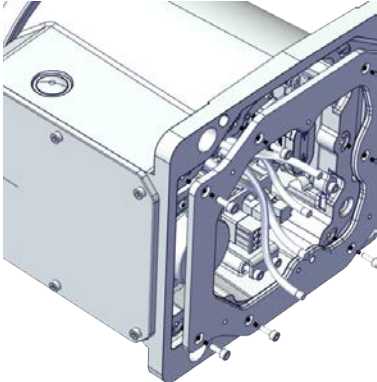
	Action	Note
2	<p> CAUTION</p> <p>For robots with protection type Clean Room Always cut the paint with a knife and grind the paint edge when disassembling parts of the robot! See <i>Cut the paint or surface on the robot before replacing parts on page 124.</i></p>	
3	<p>Remove the connector interface plate attachment screws and carefully open the plate.</p> <p> CAUTION</p> <p>There are cabling attached to the cover. The cover cannot be removed completely until the connectors are removed.</p>	<p>Valid for cabling with rear interface</p>  <p>xx1800003034</p> <p>Valid for cabling with bottom interface (option 3309-1)</p>  <p>xx1800003055</p>
4	<p>Valid for cabling with bottom interface (option 3309-1)</p> <p>Remove the base adapter.</p>	 <p>xx1800003056</p>

Continues on next page



5 Repair

5.4.2 Replacing the swing



Continued

Removing the brake release button

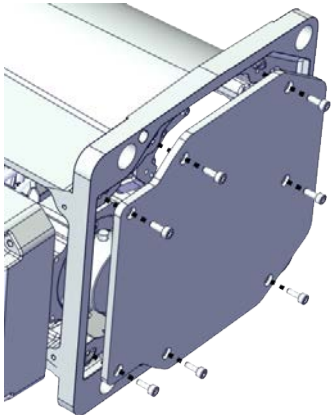
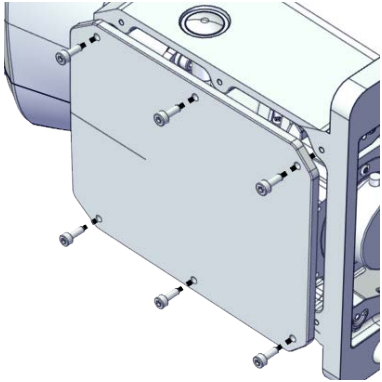
Notice that the procedure differs depending on if the connector interface is located either at the rear or at the bottom of the base.

	Action	Note
1	 DANGER Make sure that all supplies for electrical power, hydraulic pressure, and air pressure are turned off.	
2	 CAUTION For robots with protection type Clean Room Always cut the paint with a knife and grind the paint edge when disassembling parts of the robot! See Cut the paint or surface on the robot before replacing parts on page 124 .	
3	Valid for cabling with rear interface Remove the base bottom cover.	 xx1800003035
4	Valid for cabling with bottom interface (option 3309-1) Remove the base rear cover.	 xx1800003057

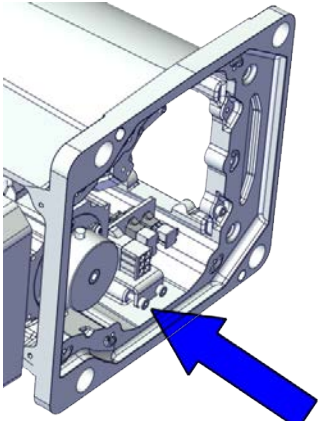
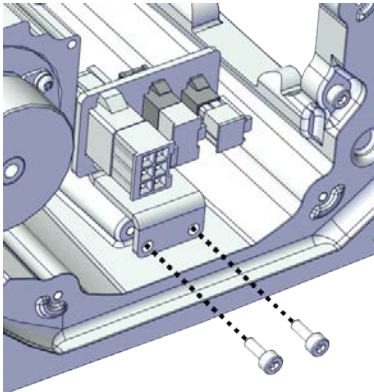
Continues on next page

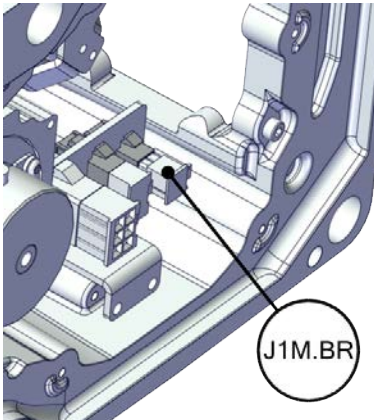
	Action	Note
5	Disconnect the earth cable.	 <p>xx1800003036</p>
6	Remove the connector plate.	 <p>xx1800003037</p>
7	Disconnect the connector. <ul style="list-style-type: none"> • J1M.BR  Tip Take photos of the connector and cable position before disconnecting them, to have as a reference when reconnecting.	 <p>xx1800003038</p>

Continues on next page



5 Repair

5.4.2 Replacing the swing

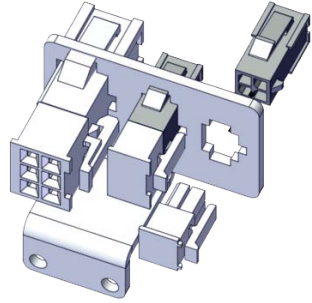
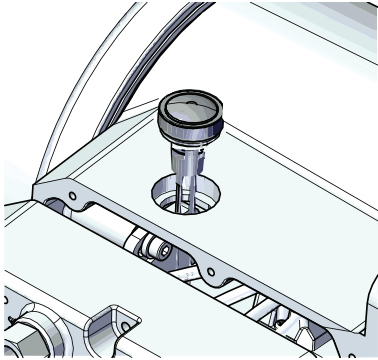
Continued

	Action	Note
8	Remove the female header of the J1M.BR connector from the connector plate.	 <p>xx1800003039</p>
9	Remove the brake release button from the base using the tool.	<p>brake release button assembly tool, included in the special toolkit 3HAC071022-001</p>  <p>xx1800003040</p>



Disconnecting axis-1 motor connectors

	Action	Note
1	 <p>DANGER</p> <p>Make sure that all supplies for electrical power, hydraulic pressure, and air pressure are turned off.</p>	
2	 <p>CAUTION</p> <p>For robots with protection type Clean Room Always cut the paint with a knife and grind the paint edge when disassembling parts of the robot! See Cut the paint or surface on the robot before replacing parts on page 124.</p>	

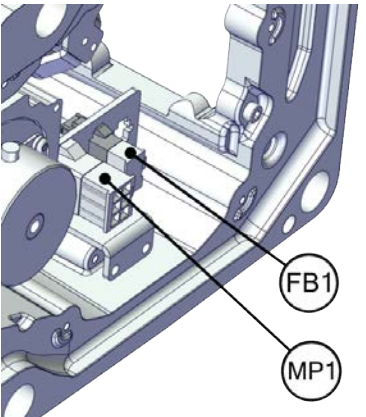
Continues on next page

	Action	Note
3	<p>Disconnect the connectors.</p> <ul style="list-style-type: none"> • FB1 • MP1 <p> Tip</p> <p>Take photos of the connector and cable position before disconnecting them, to have as a reference when reconnecting.</p>	 <p>xx1800003041</p>

Separating the cable package from the base

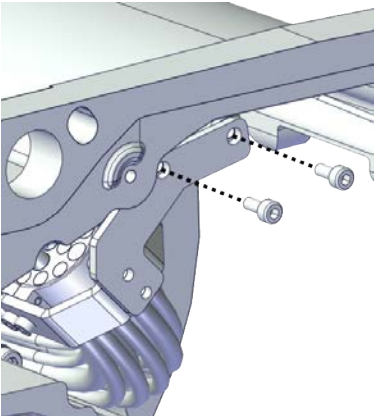
	Action	Note
1	<p> DANGER</p> <p>Make sure that all supplies for electrical power, hydraulic pressure, and air pressure are turned off.</p>	
2	<p> CAUTION</p> <p>For robots with protection type Clean Room</p> <p>Always cut the paint with a knife and grind the paint edge when disassembling parts of the robot! See Cut the paint or surface on the robot before replacing parts on page 124.</p>	
3	<p>Remove the cable bracket.</p>	 <p>xx1800003042</p>



Continues on next page

5 Repair



5.4.2 Replacing the swing

Continued

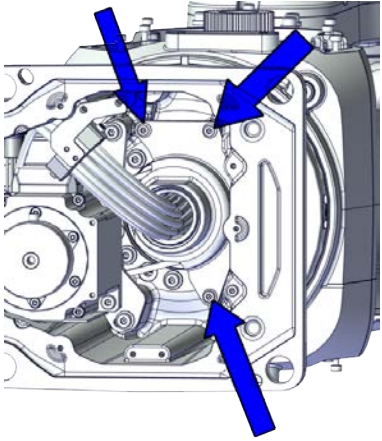
Separating the cable package from the axis-1 gearbox

	Action	Note
1	 DANGER Make sure that all supplies for electrical power, hydraulic pressure, and air pressure are turned off.	
2	 CAUTION For robots with protection type Clean Room Always cut the paint with a knife and grind the paint edge when disassembling parts of the robot! See Cut the paint or surface on the robot before replacing parts on page 124.	
3	Remove the pulley cover.	 <small>xx1800003043</small>

Pulling out the cable package

	Action	Note
1	 DANGER Make sure that all supplies for electrical power, hydraulic pressure, and air pressure are turned off.	
2	 CAUTION For robots with protection type Clean Room Always cut the paint with a knife and grind the paint edge when disassembling parts of the robot! See Cut the paint or surface on the robot before replacing parts on page 124.	

Continues on next page

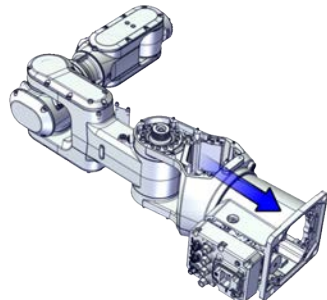
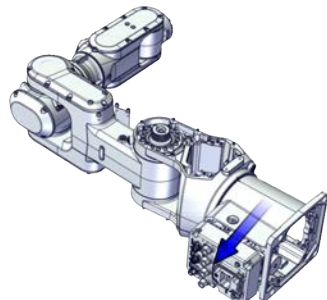
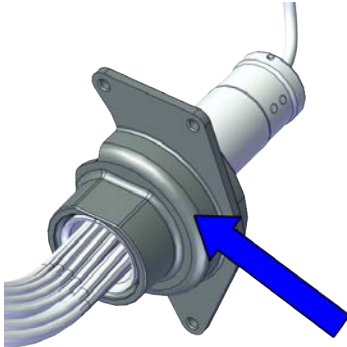
	Action	Note
3	Pull out the lower cable package from the axis-1 gearbox.	 <p>xx1800003044</p>
4	Pull out the lower cable package from the base.	 <p>xx1800003045</p>
5	Remove the pulley cover from the lower cable package.	 <p>xx1800003046</p>

Removing the axis-1 motor



	Action	Note
1	 <p>DANGER</p> <p>Make sure that all supplies for electrical power, hydraulic pressure, and air pressure are turned off.</p>	

Continues on next page

5 Repair

5.4.2 Replacing the swing

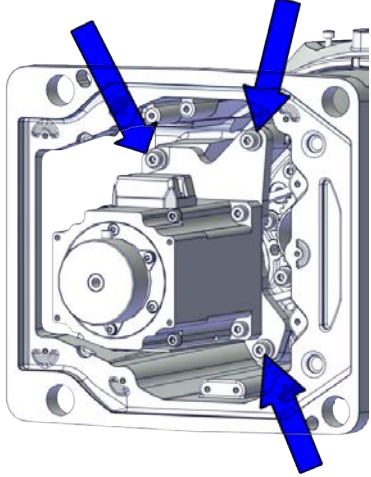
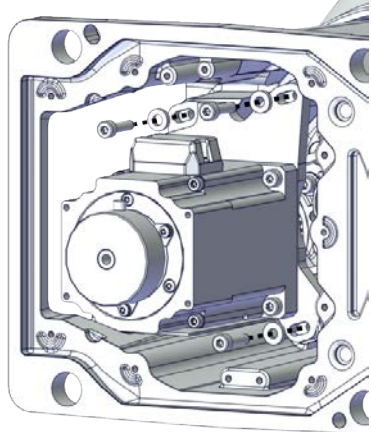

Continued

	Action	Note
2	<p> CAUTION</p> <p>For robots with protection type Clean Room Always cut the paint with a knife and grind the paint edge when disassembling parts of the robot! See Cut the paint or surface on the robot before replacing parts on page 124.</p>	
3	<p> CAUTION</p> <p>Removing motors will release axes. This means the axes can fall down. Make sure axes are well supported before removing motors.</p>	
4	<p>Loosen the screws and move the motor slightly to slacken the timing belt.</p>	 <p>xx1800003064</p>
5	<p>Remove the screws and washers.</p>	 <p>xx1800003065</p>

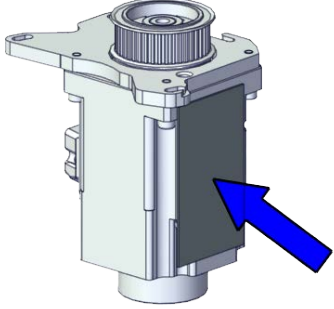
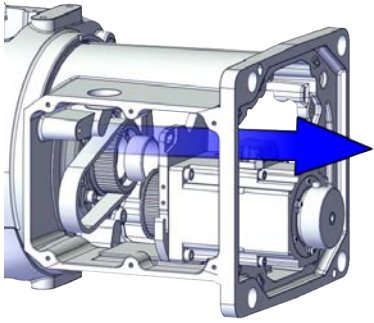
Continues on next page

	Action	Note
6	<p>Carefully lift out the motor.</p> <p> CAUTION</p> <p>A cooling pad is attached to the motor, which may stick to the casting. Always use a plastic sheet with caution to remove the pad from the casting. Pay attention not to scratch the casting or damage the pad.</p>	<p>Cooling pad location</p>  <p>xx1800003602</p>
7	<p>Remove the timing belt from its groove on the motor.</p>	 <p>xx1800003066</p>

Removing the axis-1 timing belt

	Action	Note
1	<p> DANGER</p> <p>Make sure that all supplies for electrical power, hydraulic pressure, and air pressure are turned off.</p>	
2	<p> CAUTION</p> <p>For robots with protection type Clean Room</p> <p>Always cut the paint with a knife and grind the paint edge when disassembling parts of the robot! See Cut the paint or surface on the robot before replacing parts on page 124.</p>	
3	<p> CAUTION</p> <p>Loosening timing belts will release axes. This means the axes can fall down.</p> <p>Make sure axes are well supported before loosening timing belts.</p>	

Continues on next page



5 Repair

5.4.2 Replacing the swing

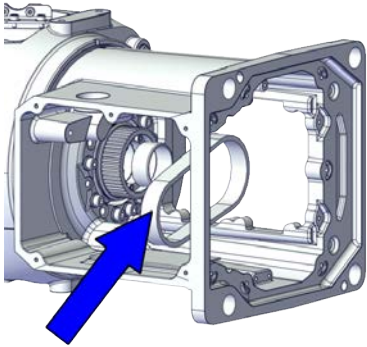

Continued

	Action	Note
4	Remove the timing belt from its groove on the gearbox.	 xx1800003067

Separating the base from the swing

	Action	Note
1	 DANGER Make sure that all supplies for electrical power, hydraulic pressure, and air pressure are turned off.	
2	 CAUTION For robots with protection type Clean Room Always cut the paint with a knife and grind the paint edge when disassembling parts of the robot! See Cut the paint or surface on the robot before replacing parts on page 124 .	

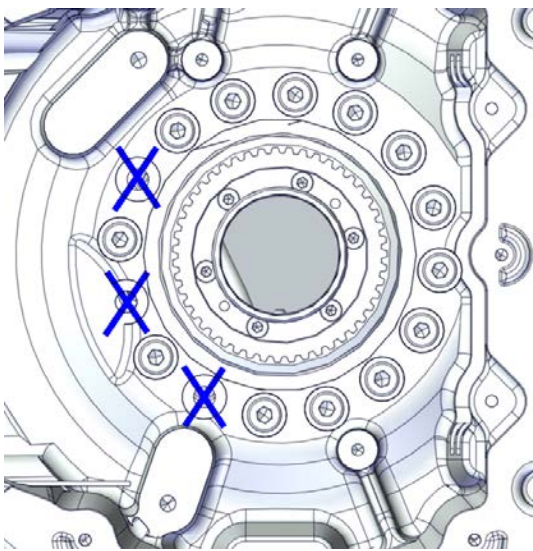
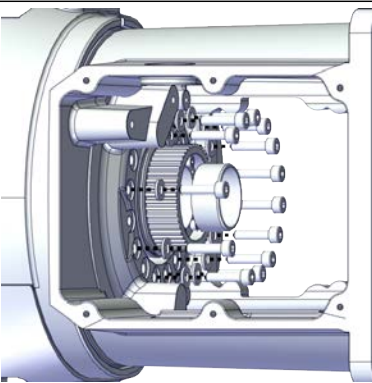
Continues on next page

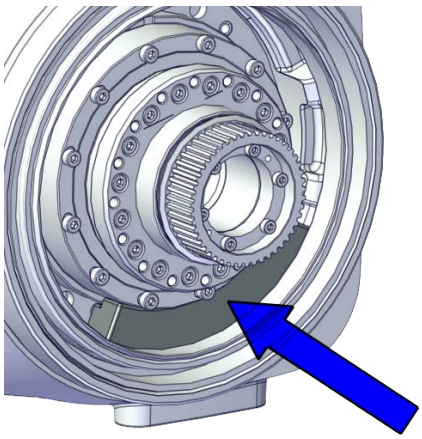
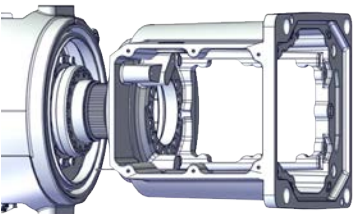
	Action	Note
<p>3</p>	<p>Remove the screws and washers.</p> <p> Tip</p> <p>Three screw holes have no screws fitted in. Take photos of the screw and washer position before removing them, to have as a reference when refitting.</p>  <p>xx1800003068</p>	 <p>xx1800003069</p>
<p>4</p>	<p>Separate the base from the swing.</p> <p> CAUTION</p> <p>The axis-1 mechanical stop is accessible now. Put it aside for later refitting.</p>  <p>xx1800003071</p>	 <p>xx1800003070</p>



Continues on next page

5 Repair

5.4.2 Replacing the swing



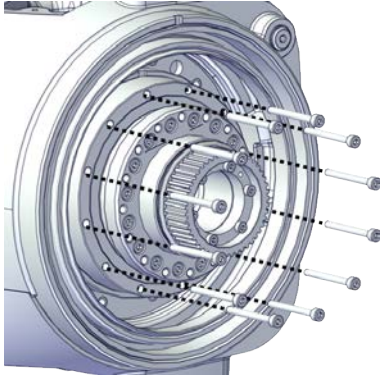
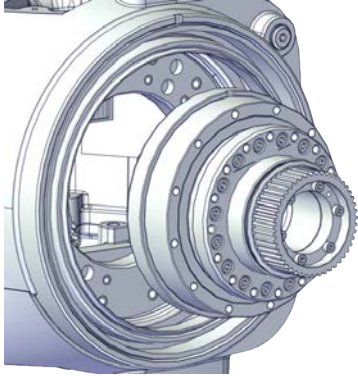

Continued

Removing the axis-1 gearbox

	Action	Note
1	 DANGER Make sure that all supplies for electrical power, hydraulic pressure, and air pressure are turned off.	
2	 CAUTION For robots with protection type Clean Room Always cut the paint with a knife and grind the paint edge when disassembling parts of the robot! See Cut the paint or surface on the robot before replacing parts on page 124 .	
3	 CAUTION Removing gearboxes will release axes. This means the axes can fall down. Make sure axes are well supported before removing gearboxes.	
4	Remove the screws.	 xx1800003073
5	Pull out the gearbox.	 xx1800003074

Continues on next page

Separating the swing from the lower arm

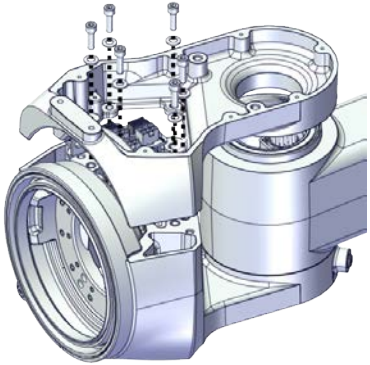
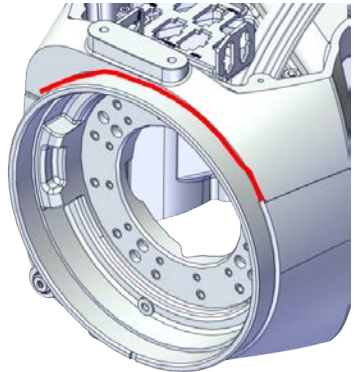
	Action	Note
1	 DANGER Make sure that all supplies for electrical power, hydraulic pressure, and air pressure are turned off.	
2	 CAUTION For robots with protection type Clean Room Always cut the paint with a knife and grind the paint edge when disassembling parts of the robot! See Cut the paint or surface on the robot before replacing parts on page 124.	
3	Remove the swing support.  Note For Clean Room robots, the swing support is sealed with sealant (marked red in the figure). Always remove swing support carefully.  Tip If the swing support is hard to loosen from the lower arm, use a plastic hammer to knock on the swing support lightly.	 <p>xx1800003076</p>  <p>xx200000320</p>
4	Route the upper cable package out of the swing support.	

Continues on next page

5 Repair

5.4.2 Replacing the swing

Continued

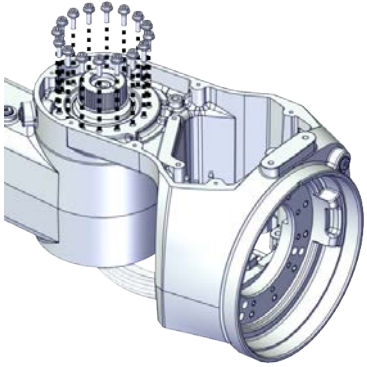
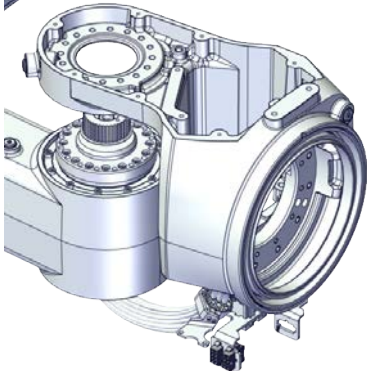
	Action	Note
5	<p>Remove the screws.</p> <p> Note</p> <p>Some robots may be fitted with separate screws and washers. During replacement, always use the same screws (and washers) that are fitted on the robot at delivery. Contact ABB for more information.</p>	 <p>xx1900002192</p>
6	<p>Separate the swing from the lower arm.</p>	 <p>xx1800003078</p>

Refitting the swing

Use these procedures to refit the swing.

Checking the radial sealing on the swing (IP67 and Clean Room)

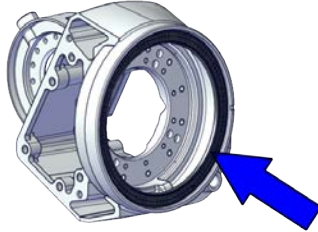
	Action	Note
1	<p>For robots with protection type Clean Room: Clean the joints that have been opened and wipe the parts free from particles with spirit on a lint free.</p>	
2	<p>Check the radial sealing on the swing. Replace if damaged, as described below. In order to replace the radial sealing, both the axis-1 mechanical stop and the axis-1 gearbox must be removed from the swing, if not already removed.</p>	 <p>xx1900002200</p>
3	<p>Apply a little grease to the new sealing when replacing the radial sealing and wipe clean after the replacement.</p>	<p>Grease: 3HAC029132-001</p>

Continues on next page

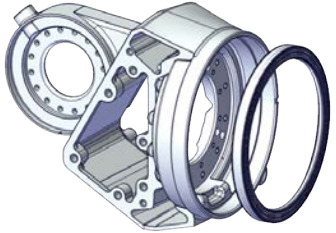
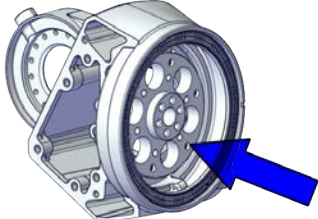
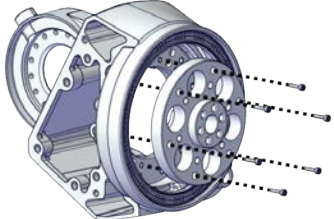
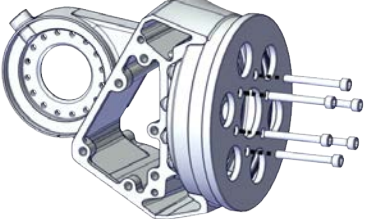
	Action	Note
4	Place the new sealing in its groove in the swing.	 <p>xx1900002154</p>
5	Place the small circular plate of the radial sealing fitting tool in and against the swing.	<p>Axis-1 radial sealing assembly tool, included in the radial sealing assembly tool set 3HAC074609-001.</p>  <p>xx1900002155</p>
6	Secure the small circular plate with screws.	 <p>xx2000000305</p>
7	Place the large circular plate of the radial sealing fitting tool against the radial sealing and fix with six M6x50 screws.	 <p>xx1900002156</p>
8	Screw the screws, little by little and evenly, to press the sealing into place.	
9	Remove the assembly tool.	
10	Check that the sealing is undamaged and properly fitted.	

Continues on next page

5 Repair

5.4.2 Replacing the swing

Continued

Checking the radial sealing on the swing support (IP67 or Clean Room)

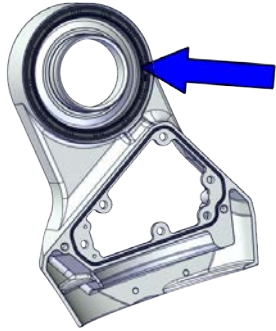
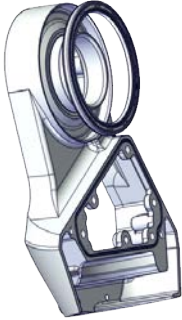
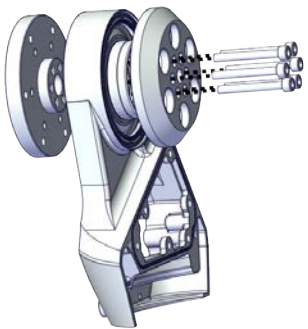
	Action	Note
1	For robots with protection type Clean Room: Clean the joints that have been opened and wipe the parts free from particles with spirit on a lint free.	
2	Check the radial sealing on the swing support. Replace if damaged, as described below.	 xx1900002201
3	Apply a little grease to the new sealing when replacing the radial sealing and wipe clean after the replacement.	Grease: 3HAC029132-001
4	Place the new sealing in its groove in the swing support.	 xx1900002157
5	Place the dish-shaped plate of the radial sealing fitting tool against the radial sealing.	Axis-2 radial sealing assembly tool, included in the radial sealing assembly tool set 3HAC074609-001.
6	Fit the circular plate to the other side of the swing support with six M6x50 screws.	
		 xx1900002158

Continues on next page

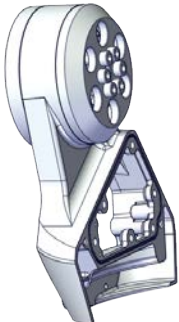
	Action	Note
7	Screw the screws, little by little, to press the sealing into place.	 <p>xx1900002159</p>
8	Remove the assembly tool.	
9	Check that the sealing is undamaged and properly fitted.	

Refitting the swing to the lower arm

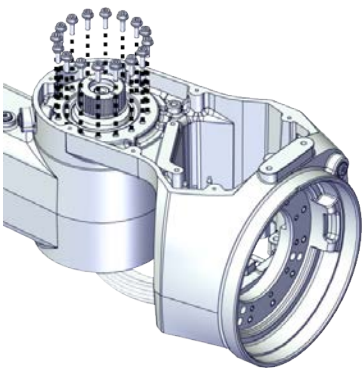

	Action	Note
1	For robots with protection type Clean Room: Clean the joints that have been opened and wipe the parts free from particles with spirit on a lint free.	
2	<p>Refit the swing to the lower arm.</p> <p> Note</p> <p>Some robots may be fitted with separate screws and washers. During replacement, always use the same screws (and washers) that are fitted on the robot at delivery. Contact ABB for more information.</p>	<p>Flange screws (16 pcs)</p> <p>For robots with protection class IP40 Tightening torque: 4.2 Nm</p> <p>For robots with protection class IP67 Tightening torque: 4 Nm</p> <p>For robots with protection type Clean Room Tightening torque: 4 Nm</p>  <p>xx1900002192</p>
3	Route the cable package through the swing support.	

Continues on next page

5 Repair

5.4.2 Replacing the swing

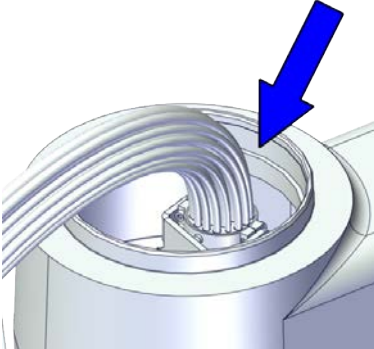
Continued

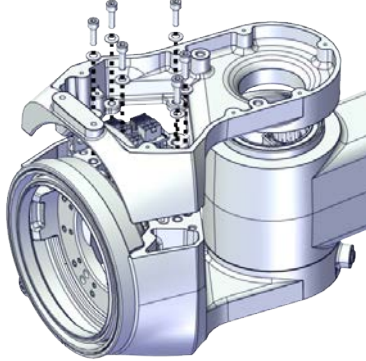
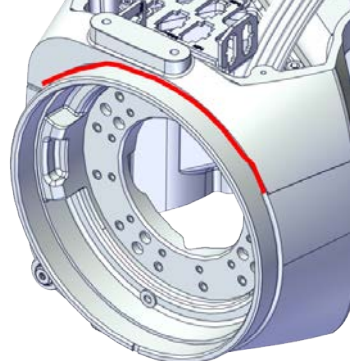
	Action	Note
4	<p>Apply grease Castrol Molub-Alloy 777-1 NG to the inner surface of the lower arm, where contacts the bearing on the swing support.</p>	 <p>xx2000000058</p>
5	<p>Refit the swing support.</p> <p> Tip</p> <p>If the swing support is hard to closely fit to the lower arm, use a plastic hammer to knock on the swing support lightly.</p>	<p>Screw: M5x16 12.9 Lafre 2C2B/FC6.9 (6 pcs) Tightening torque: 6 Nm</p>  <p>xx1800003076</p>
6	<p>For robots with protection type Clean Room (option 3351-4)</p> <p>Apply a string of the sealant Sikaflex 521FC to the joint of the swing support. Smooth out the sealant string using a finger tip.</p> <p>Use washing-up on finger tips to get a smooth joint.</p> <p>If necessary, add extra sealant to get a full cover joint.</p>	 <p>xx2000000320</p>

Refitting the axis-1 gearbox

	Action	Note
1	<p>For robots with protection type Clean Room:</p> <p>Clean the joints that have been opened and wipe the parts free from particles with spirit on a lint free.</p>	

Continues on next page

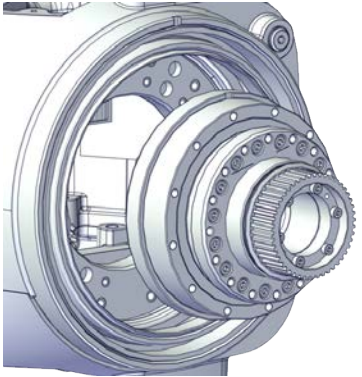
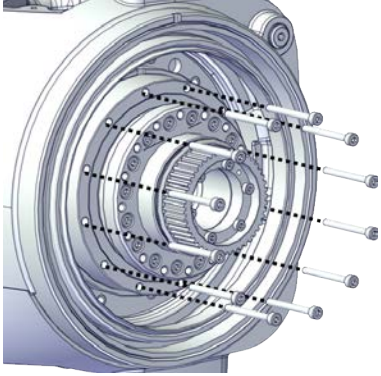
	Action	Note
2	<p>Refit the axis-1 gearbox. Make sure the locking screw hole on the gearbox is aligned with the notch on the swing casting.</p>	 <p>xx1800003074</p>
3	<p>Secure with screws.</p>	<p>Screw: M3x30 12.9 Lafre 2C2B/FC6.9 (12 pcs) Tightening torque: 1.6 Nm</p>  <p>xx1800003073</p>

Placing the axis-1 mechanical stop

	Action	Note
1	<p>For robots with protection type Clean Room: Clean the joints that have been opened and wipe the parts free from particles with spirit on a lint free.</p>	
2	<p>Check the axis-1 mechanical stop. Replace if damaged.</p>	<p>Mechanical stop, axis 1: 3HAC061947-001</p>

Continues on next page

5 Repair

5.4.2 Replacing the swing

Continued

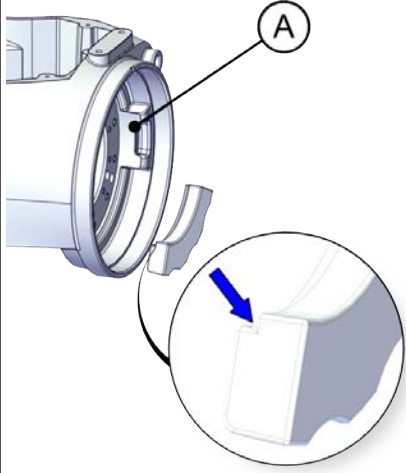
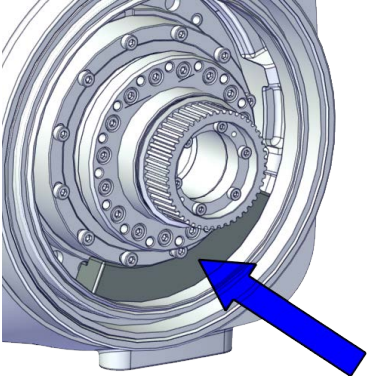
	Action	Note
3	<p>Put the axis-1 mechanical stop in place in the swing.</p> <p> Note</p> <p>The mechanical stop can be placed in any place except the block (A) on the swing. Make sure the mechanical stop step pointed in the figure is facing the swing when putting.</p> 	 <p>xx1800003071</p>
	xx1800003619	

Refitting the base to the swing

	Action	Note
1	<p>For robots with protection type Clean Room: Clean the joints that have been opened and wipe the parts free from particles with spirit on a lint free.</p>	

Continues on next page

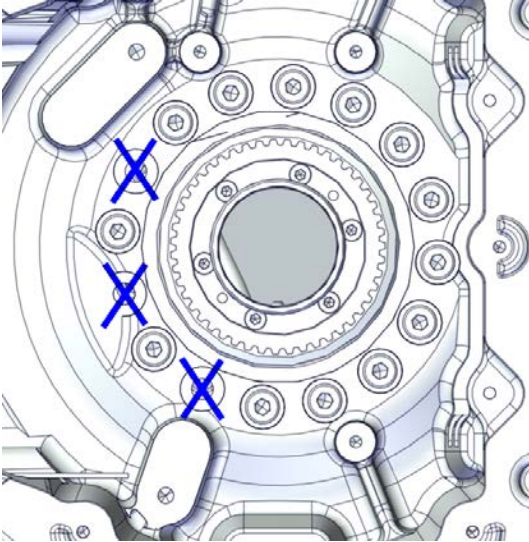
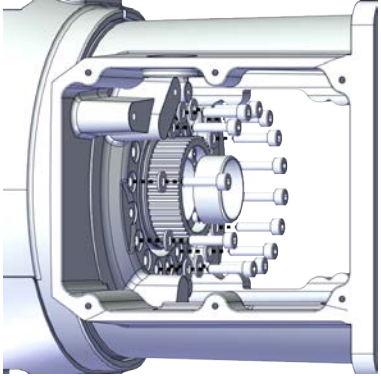
	Action	Note
2	<p>Refit the base to the swing.</p> <p> Note</p> <p>Pay attention to the screw and washer location.</p>  <p>xx1800003068</p>	<p>Screw: M4x16 12.9 Lafre 2C2B/FC6.9 (13 pcs) Tightening torque: 4.4 Nm</p>  <p>xx1800003069</p>

Refitting the brake release button

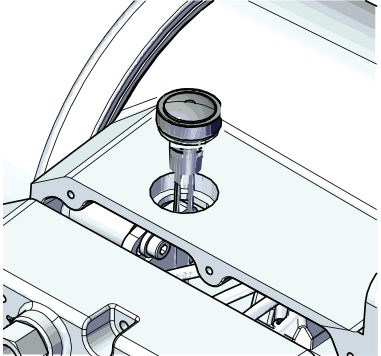
	Action	Note
1	<p>For robots with protection type Clean Room: Clean the joints that have been opened and wipe the parts free from particles with spirit on a lint free.</p>	
2	<p>Refit the brake release button.</p> <p> Note</p> <p>Do not reconnect the connector yet. Do not tighten the button yet.</p>	<p>brake release button assembly tool, included in the special toolkit 3HAC071022-001</p>  <p>xx1800003040</p>

Continues on next page

5 Repair



5.4.2 Replacing the swing

Continued

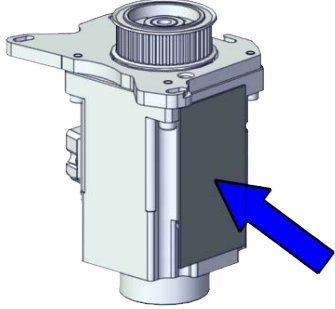
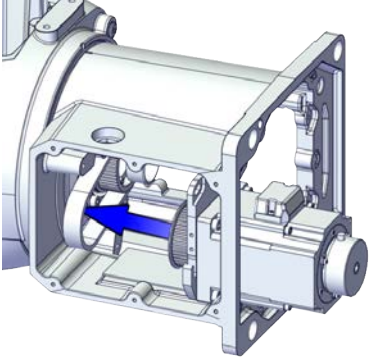
Refitting the axis-1 motor

	Action	Note
1	For robots with protection type Clean Room: Clean the joints that have been opened and wipe the parts free from particles with spirit on a lint free.	
2	Check that: <ul style="list-style-type: none">• all assembly surfaces are clean and without damages• the motor is clean and undamaged.	
3	Check the cooling pad. Replace if damaged.	Cooling pad for axis-1 and -2 motors: 3HAC071020-001  xx1800003602
4	Install the timing belt to the motor pulley and verify that the belt runs correctly in the groove of the pulley.	 xx1800003085

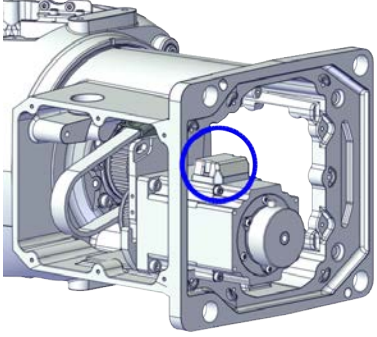
Continues on next page

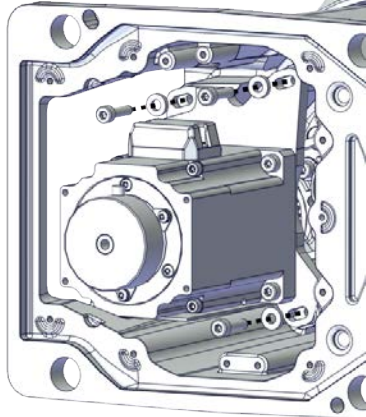
	Action	Note
5	Orient the motor correctly and fit it into the base. At the same time, install the timing belt to the gearbox pulley and verify that the belt runs correctly in the groove of the pulley.	Motor orientation: orient the motor according to the figure below, in regard to the encircled motor connector.  xx1800003072
6	Refit the screws and washers.  Note Do not tighten the screws yet.	Screw: M4x16 12.9 Lafre 2C2B/FC6.9 (3 pcs) Washer, 3HAC063985-001 (3 pcs)  xx1800003065

Adjusting the axis-1 timing belt tension

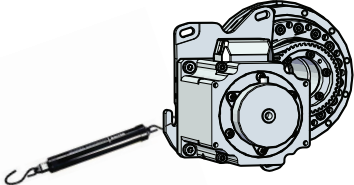

	Action	Note
1	For robots with protection type Clean Room: Clean the joints that have been opened and wipe the parts free from particles with spirit on a lint free.	
2	Use a handheld dynamometer hooking to the motor.	 xx1900000040

Continues on next page

5 Repair

5.4.2 Replacing the swing

Continued

	Action	Note
3	<p>Pull the dynamometer to make the tension falling in the allowed force range.</p> <p> Note</p> <p>During the measurement, make sure that all interferences that may affect the force are removed. Pay attention to the force application direction.</p>	<p>Used belt: 58.24-63.56 N New belt:83.2-90.8 N (for reference only)</p>  <p>xx190000041</p>
4	Secure the motor with the screws.	Tightening torque: 3 Nm

Securing the brake release button

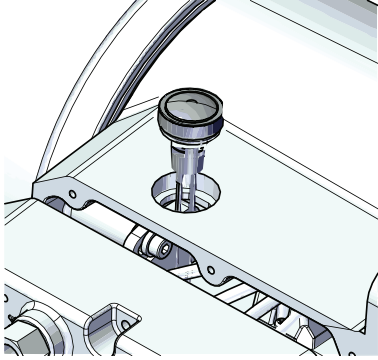



	Action	Note
1	For robots with protection type Clean Room: Clean the joints that have been opened and wipe the parts free from particles with spirit on a lint free.	
2	Tighten the brake release button using the tool.	<p>brake release button assembly tool, included in the special toolkit 3HAC071022-001</p>  <p>xx1800003040</p>

Refitting the lower cable package through the axis-1 gearbox

Notice that the procedure differs depending on if the connector interface is located either at the rear or at the bottom of the base.

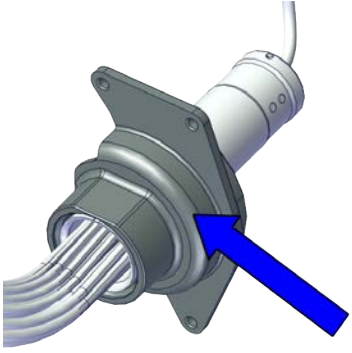
	Action	Note
1	For robots with protection type Clean Room: Clean the joints that have been opened and wipe the parts free from particles with spirit on a lint free.	

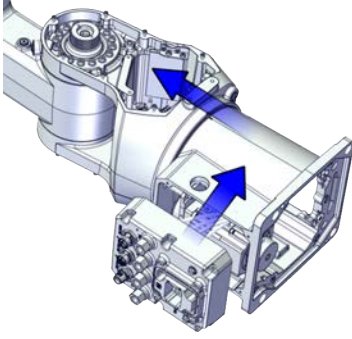
Continues on next page





	Action	Note
2	Refit the pulley cover to the lower cable package.	 <p>xx1800003046</p>
3	<p>Valid for cabling with rear interface Insert the cable package in the base and up through the axis-1 gearbox, through the rear.</p> <p> Tip Wrap the connectors with the masking tape.</p> <p> CAUTION Make sure that no cables or hoses are twisted or strained. Reroute if necessary.</p>	 <p>xx1800003047</p> <p>Cable protection tube orientation: use the encircled notch on the cable protection tube as a reference when inserting the cable package, which should be at the opposite direction to the locking screw hole on the gearbox.</p>  <p>xx1800003048</p>

Continues on next page

5 Repair

5.4.2 Replacing the swing

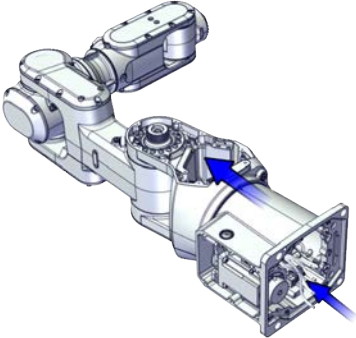
Continued

	Action	Note
4	<p>Valid for cabling with bottom interface (option 3309-1)</p> <p>Insert the cable package in the base and up through the axis-1 gearbox, through the bottom.</p> <p> Tip</p> <p>Wrap the connectors with the masking tape.</p> <p> CAUTION</p> <p>Make sure that no cables or hoses are twisted or strained. Reroute if necessary.</p>	 <p>xx1800003060</p> <p>Cable protection tube orientation: use the encircled notch on the cable protection tube as a reference when inserting the cable package, which should be at the opposite direction to the locking screw hole on the gearbox.</p>  <p>xx1800003048</p>

Securing the lower cable package to the axis-1 gearbox

	Action	Note
1	<p>For robots with protection type Clean Room: Clean the joints that have been opened and wipe the parts free from particles with spirit on a lint free.</p>	

Continues on next page

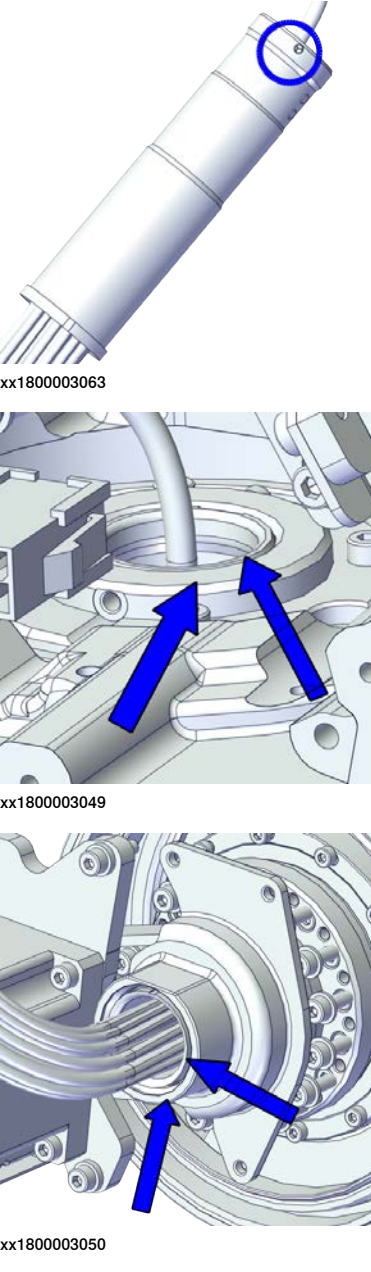

	Action	Note
2	<p>Make sure that:</p> <ul style="list-style-type: none">• The hole on the cable protection tube is aligned with the locking screw hole on the gearbox.• The cable protection tube surface is completely parallel with the pulley cover at one side and with the flange at the other side.	 <p>The diagram consists of three parts. The top part shows a close-up of a cable protection tube with a blue circle highlighting a hole on its side. The middle part shows the tube being inserted into a pulley cover, with two blue arrows pointing to the contact surfaces. The bottom part shows the tube inserted into a gearbox flange, with two blue arrows pointing to the alignment of the tube's hole with a locking screw hole.</p> <p>xx1800003063</p> <p>xx1800003049</p> <p>xx1800003050</p>

Continues on next page

5 Repair

5.4.2 Replacing the swing

Continued

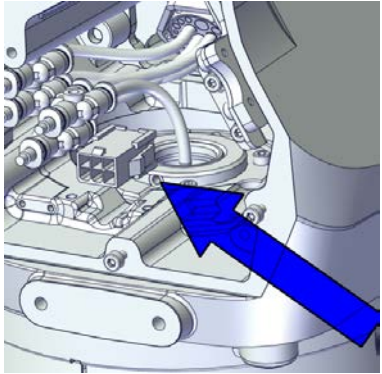
	Action	Note
3	<p>Apply a little Loctite 243 to the locking screw and refit the locking screw.</p> <p> Note</p> <p>Make sure the locking screw header is parallel with flange surface.</p> <p> Note</p> <p>If there is locking liquid residues on the screw or screw hole, please clean it before refitting. Remove residual locking liquid after refitting.</p>	<p>Screw: M3x8 (1 pcs) Tightening torque: 0.4 Nm</p>  <p>xx1800003032</p>

Refitting the pulley cover

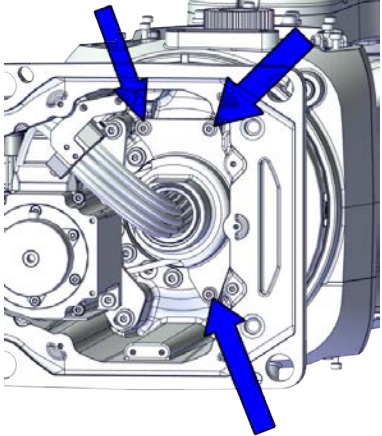
	Action	Note
1	<p>For robots with protection type Clean Room: Clean the joints that have been opened and wipe the parts free from particles with spirit on a lint free.</p>	
2	<p>Refit the puller cover.</p>	<p>Screw: M3x8 12.9 Lafre 2C2B/FC6.9 (3 pcs) Tightening torque: 1.2 Nm</p>  <p>xx1800003043</p>



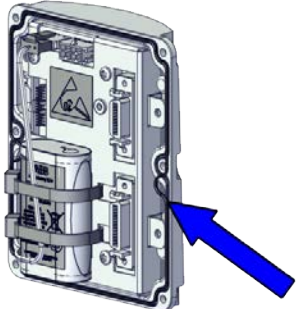

Checking the SMB cover gasket

	Action	Note
1	<p>For robots with protection type Clean Room: Clean the joints that have been opened and wipe the parts free from particles with spirit on a lint free.</p>	

Continues on next page

	Action	Note
2	<p>For robots with protection class IP67 (option 3350-670) For robots with protection type Clean Room (option 3351-4) Check the gasket. Replace if damaged.</p>	 <p>xx1900002186</p>

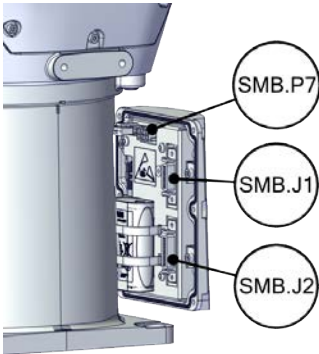
Reconnecting the SMB connectors

	Action	Note
1	 <p>ELECTROSTATIC DISCHARGE (ESD)</p> <p>The unit is sensitive to ESD. Before handling the unit read the safety information in section The unit is sensitive to ESD on page 49.</p>	
2	<p>For robots with protection type Clean Room Clean the joints that have been opened and wipe the parts free from particles with spirit on a lint free.</p>	
3	<p>Reconnect the connectors.</p> <ul style="list-style-type: none"> • SMB.P7 • SMB.J1 • SMB.J2  <p>Tip</p> <p>See the number markings on the connectors for help to find the corresponding connector.</p>	<p>Tightening torque: 0.3 Nm</p>  <p>xx1800002468</p>
4	<p>Route and secure the cabling with cable straps.</p>  <p>CAUTION</p> <p>Correct cable routing is highly important. If the cables are routed and secured incorrectly the cables can be damaged.</p>	

Continues on next page

5 Repair

5.4.2 Replacing the swing

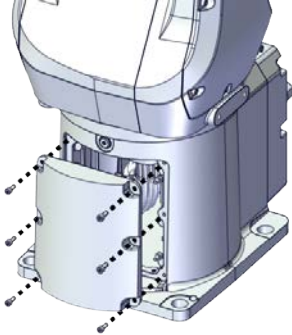

Continued

	Action	Note
5	Refit the SMB cover to the base.	<p>Screw: M3x8 12.9 Lafre 2C2B/FC6.9 (6 pcs) Tightening torque: 1.2 Nm</p>  <p>xx1800002467</p>

Refitting the connector interface plate

	Action	Note
1	For robots with protection type Clean Room: Clean the joints that have been opened and wipe the parts free from particles with spirit on a lint free.	

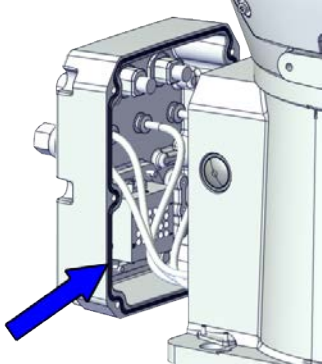
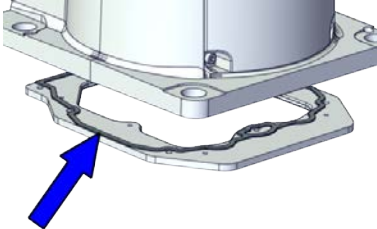
Continues on next page

	Action	Note
2	<p>For robots with protection class IP67 (option 3350-670) For robots with protection type Clean Room (option 3351-4) Check the gasket. Replace if damaged.</p>	<p>Valid for cabling with rear interface Gasket for base rear: 3HAC065350-001</p>  <p>xx1900002183</p> <p>Valid for cabling with bottom interface (option 3309-1) Gasket for base bottom: 3HAC065345-001</p>  <p>xx1900002188</p>
3	<p>Route and secure the cabling with cable straps.</p> <p> CAUTION</p> <p>Correct cable routing is highly important. If the cables are routed and secured incorrectly the cables can be damaged.</p>	

Continues on next page

5 Repair

5.4.2 Replacing the swing

Continued

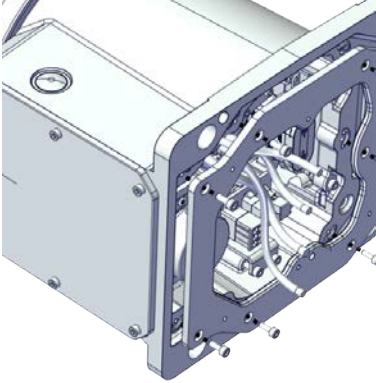
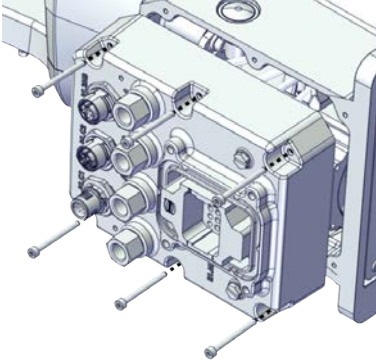
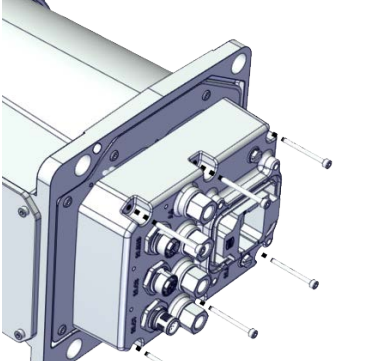
	Action	Note
4	<p>Valid for cabling with bottom interface (option 3309-1)</p> <p>Refit the base adapter.</p>	<p>Screw: M3x8 Steel 8.8-A2F (7 pcs) Tightening torque: 1.2 Nm</p>  <p>xx1800003056</p>
5	<p>Refit the connector interface plate to the base.</p>	<p>Screw: M3x30 12.9 Lafre 2C2B/FC6.9 (6 pcs) Tightening torque: 1.2 Nm</p> <p>Valid for cabling with rear interface</p>  <p>xx1800003034</p> <p>Valid for cabling with bottom interface (option 3309-1)</p>  <p>xx1800003055</p>

Continues on next page

Securing the lower cable package to the base

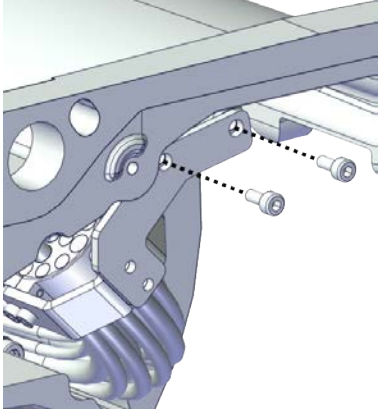
	Action	Note
1	For robots with protection type Clean Room: Clean the joints that have been opened and wipe the parts free from particles with spirit on a lint free.	
2	Refit the cable bracket.	<p>Screw: M2.5x6 12.9 Lafre 2C2B/FC6.9 (2 pcs) Tightening torque: 0.6 Nm</p>  <p>xx1800003042</p>

Reconnecting the brake release cabling and axis-1 motor connectors

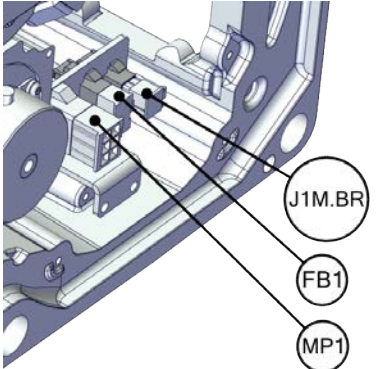
	Action	Note
1	For robots with protection type Clean Room: Clean the joints that have been opened and wipe the parts free from particles with spirit on a lint free.	
2	<p>Reconnect the connectors.</p> <ul style="list-style-type: none"> • J1M.BR • MP1 • FB1 <p> Tip</p> <p>See the number markings on the connectors for help to find the corresponding connector.</p>	 <p>xx1800003054</p>

Continues on next page

5 Repair

5.4.2 Replacing the swing

Continued

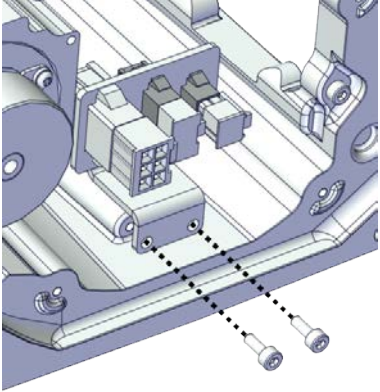
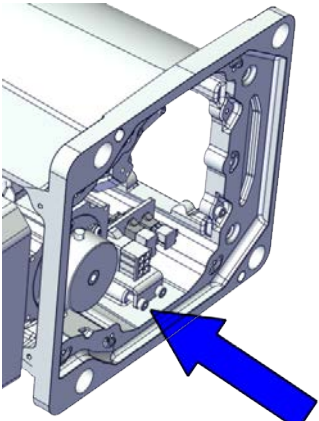

	Action	Note
3	Reconnect the floor cable together with the connector plate.	<p data-bbox="1029 315 1321 405">Screw: M3x8 12.9 Lafre 2C2B/FC6.9 (2 pcs) Tightening torque: 0.8 Nm</p>  <p data-bbox="1029 831 1136 853">xx1800003037</p>  <p data-bbox="1029 1301 1136 1323">xx1800003036</p>

Refitting the base cover

Notice that the procedure differs depending on if the connector interface is located either at the rear or at the bottom of the base.

	Action	Note
1	For robots with protection type Clean Room: Clean the joints that have been opened and wipe the parts free from particles with spirit on a lint free.	

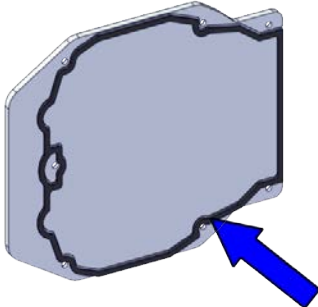
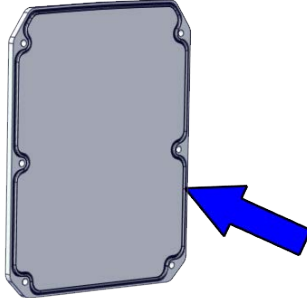
Continues on next page

	Action	Note
2	<p>For robots with protection class IP67 (option 3350-670) For robots with protection type Clean Room (option 3351-4) Check the gasket. Replace if damaged.</p>	<p>Valid for cabling with rear interface Gasket for base bottom: 3HAC065345-001</p>  <p>xx1900002184</p> <p>Valid for cabling with bottom interface (option 3309-1) Gasket for base rear: 3HAC065350-001</p>  <p>xx1900002189</p>
3	<p>Apply grease to the cable package, cover all moving area of the package.</p>	
4	<p>Apply grease to the covers that have contacting area with the cable package.</p>	
5	<p>Route and secure the cabling with cable straps.</p> <p> CAUTION</p> <p>Correct cable routing is highly important. If the cables are routed and secured incorrectly the cables can be damaged.</p>	

Continues on next page

5 Repair

5.4.2 Replacing the swing

Continued

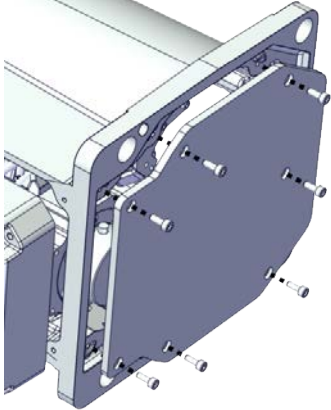
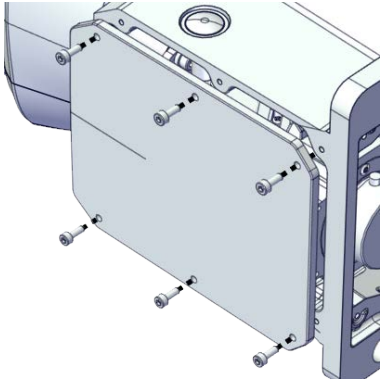

	Action	Note
6	Valid for cabling with rear interface Refit the bottom cover.	Screw: M3x8 Steel 8.8-A2F (7 pcs) Tightening torque: 1.2 Nm  xx1800003035
7	Refit the rear cover.	Screw: M3x8 12.9 Lafre 2C2B/FC6.9 (6 pcs) Tightening torque: 1.2 Nm  xx1800003057

Securing the robot to the foundation

	Action	Note
1	For robots with protection type Clean Room: Clean the joints that have been opened and wipe the parts free from particles with spirit on a lint free.	
2	 CAUTION The IRB 1100 robot weighs 21.1 kg and can be lifted by one person.	
3	Raise the robot to standing and secure to the foundation with the attachment screws and washers.	Attachment screws: M12x25 (robot installation directly on foundation), quality: 8.8. Washers: 24 x 13 x 2.5, steel hardness class 200HV. Tightening Torque: 50 Nm±5 Nm.

Continues on next page

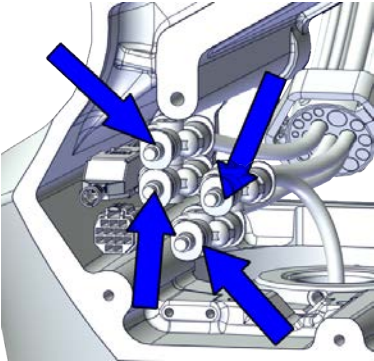
Reconnecting the air hoses, CP/CS cabling and Ethernet cabling (if equipped)

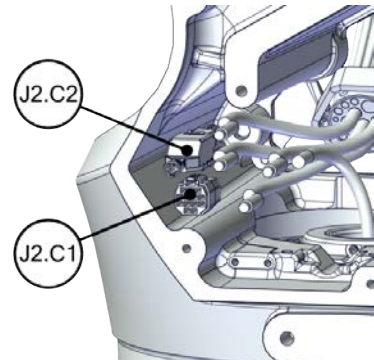
	Action	Note
1	<p>For robots with protection type Clean Room: Clean the joints that have been opened and wipe the parts free from particles with spirit on a lint free.</p>	
2	<p>Reconnect the air hoses in a cross pattern to the Y-shaped connectors.</p> <p> Tip</p> <p>See the number markings on the air hoses for help to find the corresponding air hoses. The air hoses with the same number connect to the same Y-shaped connector.</p>	 <p>xx1800002500</p>
3	<p>Reconnect the connectors.</p> <ul style="list-style-type: none"> • J2.C1 • J2.C2 <p> Tip</p> <p>See the number markings on the connectors for help to find the corresponding connector.</p>	 <p>xx1800002501</p>

Securing the cable package to the swing

	Action	Note
1	<p>For robots with protection type Clean Room: Clean the joints that have been opened and wipe the parts free from particles with spirit on a lint free.</p>	

Continues on next page

5 Repair

5.4.2 Replacing the swing



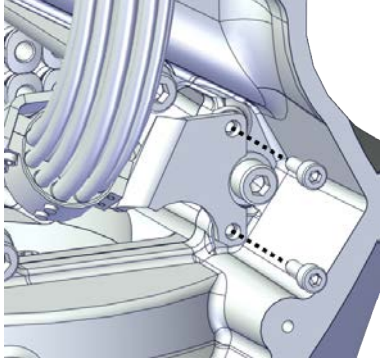

Continued

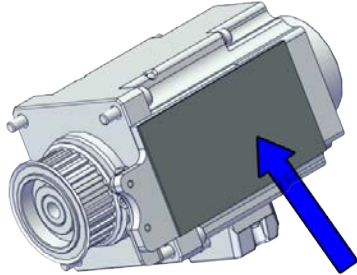
	Action	Note
2	Refit the cable bracket.	<p>Screw: M3x8 12.9 Lafre 2C2B/FC6.9 (2 pcs) Tightening torque: 0.8 Nm</p>  <p>xx1800002499</p>

Refitting the axis-2 motor

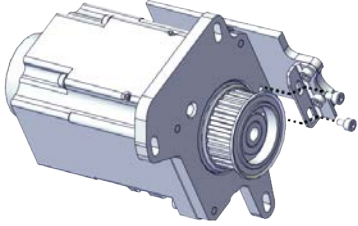
	Action	Note
1	For robots with protection type Clean Room: Clean the joints that have been opened and wipe the parts free from particles with spirit on a lint free.	
2	Check that: <ul style="list-style-type: none"> • all assembly surfaces are clean and without damages • the motor is clean and undamaged. 	
3	Check the cooling pad. Replace if damaged, as shown in the following step.	<p>Cooling pad for axis-1 and -2 motors: 3HAC071020-001</p>  <p>xx1800003603</p>

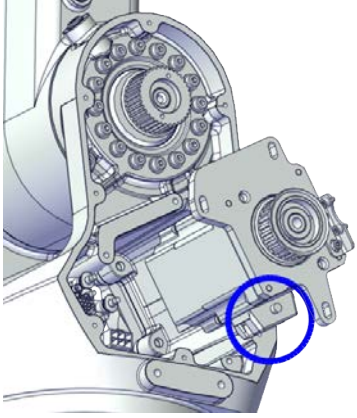
Continues on next page

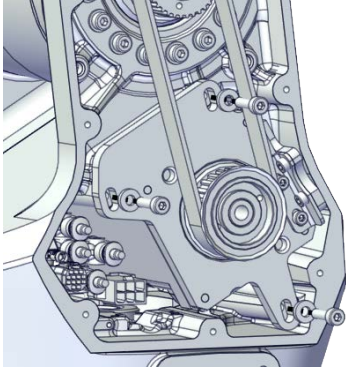

	Action	Note
4	<p>Remove the screws. Replace with a new cooling pad and then refit the screws.</p>	<p>Screw: M3x5 12.9 Lafre 2C2B/FC6.9 (2 pcs) Tightening torque: 1.2 Nm</p>  <p>xx1800003026</p>
5	<p>Orient the motor correctly and fit it into the swing.</p> <p> Tip</p> <p>Bend the motor signal cable back towards the swing support.</p>	<p>Motor orientation: orient the motor according to the figure below, in regard to the encircled motor connector.</p>  <p>xx1800003027</p>
6	<p>Refit the screws and washers.</p> <p> Note</p> <p>Do not tighten the screws yet.</p>	<p>Screw: M4x16 12.9 Lafre 2C2B/FC6.9 (3 pcs) Washer, 3HAC063985-001 (3 pcs)</p>  <p>xx1800002494</p>

Continues on next page

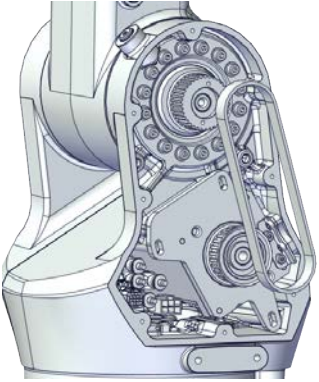

5 Repair

5.4.2 Replacing the swing

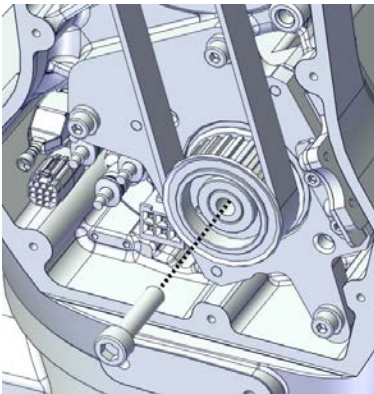
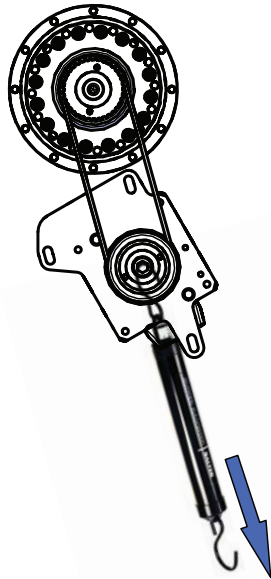
Continued

	Action	Note
7	Install the timing belt to the pulleys and verify that the belt runs correctly in the grooves of the pulleys.	 xx1800003028
8	Install an M6x25 or longer adjustment screw to the motor.  Note Do not insert the entire screw to the hole.	 xx1900000010
9	Use a handheld dynamometer hooking to the screw and pull the dynamometer to reach the initial referenced force.	Initial referenced force for used belt: 68.18-75.04 N (for reference only) Initial referenced force for new belt: 97.4-107.2 N  xx1900000029

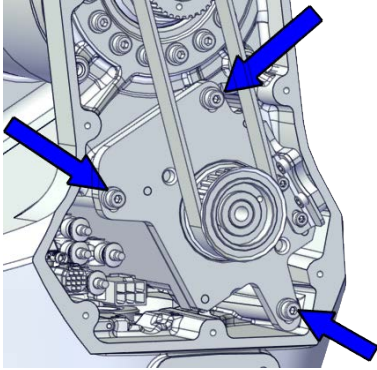
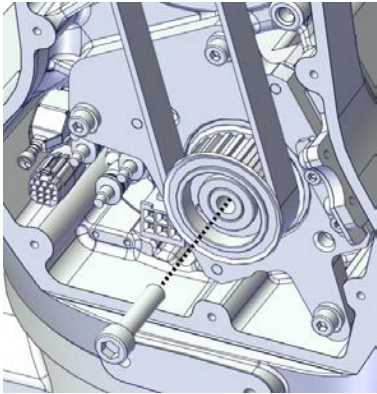
Continues on next page

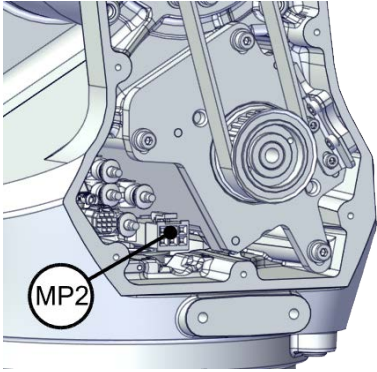
	Action	Note
10	Secure the motor with the screws.	<p>Tightening torque: 3.5 Nm</p>  <p>xx1800002493</p>
11	Use a sonic tension meter to measure the timing belt tension.	<p>Used belt: 163-174 Hz New belt: 180-229 Hz (for reference only)</p>
12	If the timing belt tension does not meet the requirement, loosen the motor screws and readjust.	
13	Remove the adjustment screw from the motor.	 <p>xx1900000010</p>
14	<p>Reconnect the connector.</p> <ul style="list-style-type: none"> • MP2  <p>Tip</p> <p>See the number markings on the connectors for help to find the corresponding connector.</p>	 <p>xx1800002495</p>





Continues on next page

5 Repair

5.4.2 Replacing the swing

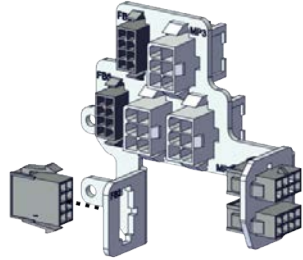
Continued

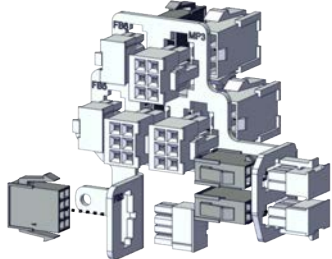
Reconnecting the connectors at the division point

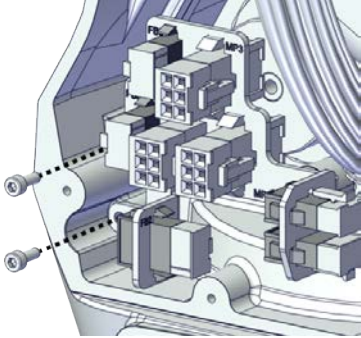
	Action	Note
1	For robots with protection type Clean Room: Clean the joints that have been opened and wipe the parts free from particles with spirit on a lint free.	
2	Insert the female header of the connectors to the connector plate.	 xx1800003029
3	Reconnect the connectors. <ul style="list-style-type: none"> • J2.FB2,3,4,5,6 • J2.MP3,4,5/6  Tip See the number markings on the connectors for help to find the corresponding connector.	 xx1800003030
4	Route and secure the cabling with cable straps.  CAUTION Correct cable routing is highly important. If the cables are routed and secured incorrectly the cables can be damaged.	
5	Refit the connector plate.	Screw: M3x8 12.9 Lafre 2C2B/FC6.9 (2 pcs) Tightening torque: 0.8 Nm  xx1800002489

Continues on next page

Refitting the swing covers

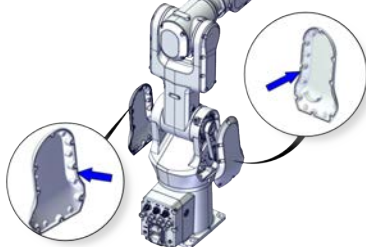
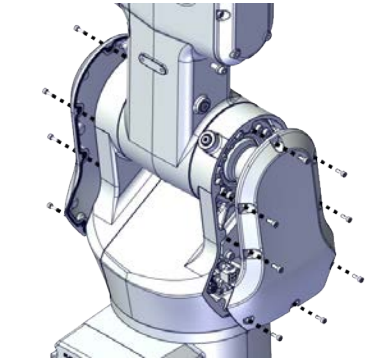
	Action	Note
1	For robots with protection type Clean Room: Clean the joints that have been opened and wipe the parts free from particles with spirit on a lint free.	
2	For robots with protection class IP67 (option 3350-670) For robots with protection type Clean Room (option 3351-4) Check the gaskets. Replace if damaged.	 xx1900002175
3	Apply grease to the cable package, cover all moving area of the package.	
4	Apply grease to the covers that have contacting area with the cable package.	
5	Refit the covers. <ul style="list-style-type: none"> • Swing cover • Swing support cover 	Screw: M3x8 12.9 Lafre 2C2B/FC6.9 Tightening torque: 1.2 Nm  xx1800003607

Concluding procedure

	Action	Note
1	For robots with protection type Clean Room: Clean and paint the joints that have been opened. See Cut the paint or surface on the robot before replacing parts on page 124 .  Note After all repair work, wipe the Clean Room robot free from particles with spirit on a lint free cloth.	
2	Recalibrate the robot.	Calibration is detailed in section Calibration on page 685 .

Continues on next page

5 Repair

5.4.2 Replacing the swing

Continued

	Action	Note
3	 DANGER Make sure all safety requirements are met when performing the first test run. See Test run after installation, maintenance, or repair on page 91 .	

5.5 Lower arm

5.5.1 Replacing the lower arm

Location of the lower arm

The lower arm is located as shown in the figure.

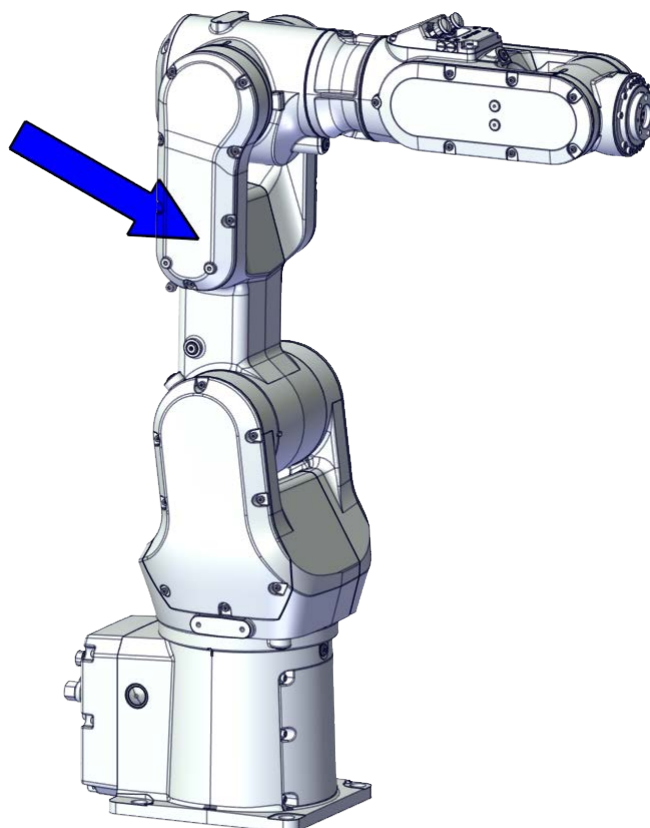

xx1800002474

Required spare parts



Note

The spare part numbers that are listed in the table can be out of date. See the latest spare parts of the IRB 1100 via myABB Business Portal, www.abb.com/myABB.

Spare part	Article number	Note
Lower arm (IRB 1100-4/0.58)	3HAC069056-001	
Lower arm with sealing ring (IRB 1100-4/0.58)	3HAC074273-001	Used with protection class IP67.
Lower arm with sealing ring, Clean Room (IRB 1100-4/0.58)	3HAC075490-001	Used with protection type Clean Room.

Continues on next page

5 Repair

5.5.1 Replacing the lower arm

Continued

Spare part	Article number	Note
Lower arm (IRB 1100-4/0.475)	3HAC069055-001	
Lower arm with sealing ring (IRB 1100-4/0.475)	3HAC074271-001	Used with protection class IP67.
Lower arm with sealing ring, Clean Room (IRB 1100-4/0.475)	3HAC075491-001	Used with protection type Clean Room.
Lower arm support	3HAC069058-001	
Lower arm support, Clean Room	3HAC075504-001	Used with protection type Clean Room.
Axis-2 radial sealing	3HAB3701-70	Used with protection class IP67 and protection type Clean Room. Replace if damaged.
Axis-3 radial sealing	3HAB3701-57	Used with protection class IP67 and protection type Clean Room. Replace if damaged.
Motor with flange, axis 2	3HAC083588-001	.
Timing belt, axis 2	3HAC061935-001	
Motor with flange, axis 3	3HAC083587-001	
Timing belt, axis 3	3HAC061936-001	
Gear unit with pulley, axis 2	3HAC073517-001	
O-ring on circular spline side	3HAB3772-143	Used with protection class IP67 and protection type Clean Room. Replace if damaged.
O-ring on flexible spline side	3HAB3772-182	Used with protection class IP67 and protection type Clean Room. Replace if damaged.
Swing cover	3HAC069051-001	
Swing cover, Clean Room	3HAC075498-001	Used with protection type Clean Room.
Swing support cover	3HAC069052-001	
Swing support cover, Clean Room	3HAC075500-001	Used with protection type Clean Room.
Lower arm cover	3HAC069057-001	
Lower arm cover, Clean Room	3HAC075503-001	Used with protection type Clean Room.
Lower arm support cover	3HAC069059-001	
Lower arm support cover, Clean Room	3HAC075505-001	Used with protection type Clean Room.
Gasket for swing cover	3HAC061959-003	Used with protection class IP67 and protection type Clean Room. Replace if damaged.
Gasket for swing support cover	3HAC065317-001	Used with protection class IP67 and protection type Clean Room. Replace if damaged.

Continues on next page

5.5.1 Replacing the lower arm

Continued

Spare part	Article number	Note
Gasket for lower arm cover	3HAC061959-006	Used with protection class IP67 and protection type Clean Room. Replace if damaged.
Gasket for lower arm support cover	3HAC065331-001	Used with protection class IP67 and protection type Clean Room. Replace if damaged.
Cooling pad for axis-1 and -2 motors	3HAC071020-001	Cooling pads are wear parts. One cooling pad sheet contains 6 pieces of small pad. Replace if damaged with one piece each time.
Cooling pad for axis-3 and -4 motors	3HAC071021-001	Cooling pads are wear parts. One cooling pad sheet includes 10 pieces of small pad. Replace if damaged with one piece each time.
Washer	3HAC063985-001	9x4.3x1, Steel

Required tools and equipment

Equipment	Article number	Note
Standard toolkit	-	Content is defined in section Standard toolkit on page 733 .
Calibration tool box, Axis Calibration	3HAC074119-001	Delivered as a set of calibration tools. Required if Axis Calibration is the valid calibration method for the robot. The tool box also includes a unique calibration pin for IRB 1100 to be fitted to the tool flange during calibration of axis 6.
24 VDC power supply	-	Used to release the motor brakes.
Sonic tension meter	-	Used for measuring the timing belt tension.
Dynamometer	-	Used for measuring the timing belt tension.

Required consumables

Consumable	Article number	Note
Cable straps	-	
Grease	3HAC029132-001	FM 222
Grease	-	Castrol Molub. Alloy 777-1 NG Used to lubricate bearings on the swing support and lower arm support.
Sealing compound	3HAC026759-002	Sikaflex 521 FC For robots with protection type Clean Room.

Continues on next page

5 Repair

5.5.1 Replacing the lower arm

Continued

Deciding calibration routine

Decide which calibration routine to be used, based on the information in the table. Depending on which routine is chosen, action might be required prior to beginning the repair work of the robot, see the table.

	Action	Note
1	<p>Decide which calibration routine to use for calibrating the robot.</p> <ul style="list-style-type: none"> Reference calibration. External cable packages (DressPack) and tools can stay fitted on the robot. Fine calibration. All external cable packages (DressPack) and tools must be removed from the robot. 	<p> Note</p> <p>Calibrating axis 6 always requires tools to be removed from the mounting flange (also for reference calibration) since the mounting flange is used for installation of the calibration tool.</p>
	<p>If the robot is to be calibrated with reference calibration:</p> <p>Find previous reference values for the axis or create new reference values. These values are to be used after the repair procedure is completed, for calibration of the robot.</p> <p>If no previous reference values exist, and no new reference values can be created, then reference calibration is not possible.</p>	<p>Follow the instructions given in the reference calibration routine on the FlexPendant to create reference values.</p> <p>Creating new values requires possibility to move the robot.</p> <p>Read more about reference calibration for Axis Calibration in Reference calibration routine on page 696.</p>
	<p>If the robot is to be calibrated with fine calibration:</p> <p>Remove all external cable packages (DressPack) and tools from the robot.</p>	



Removing the lower arm

Use these procedures to remove the lower arm.

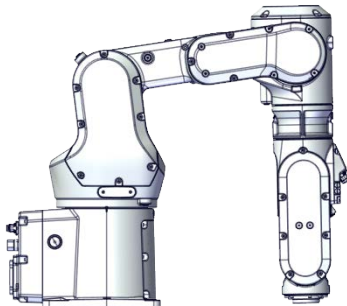

Preparations before removing the lower arm

	Action	Note
1	<p>Decide which calibration routine to use, and take actions accordingly prior to beginning the repair procedure.</p>	
2	<p>Jog the robot to the specified position:</p> <ul style="list-style-type: none"> Axis 1: 0° Axis 2: 110° (IRB 1100-4/0.475) /95° (IRB 1100-4/0.58) Axis 3: -20° (IRB 1100-4/0.475)/ -6° (IRB 1100-4/0.58) Axis 4: 0° Axis 5: 0° Axis 6: No significance. 	 <p>xx1800003289</p>

Continues on next page

	Action	Note
3	 DANGER Turn off all: <ul style="list-style-type: none"> • electric power supply • hydraulic pressure supply • air pressure supply to the robot, before entering the safeguarded space.	
4	 CAUTION For robots with protection type Clean Room Always cut the paint with a knife and grind the paint edge when disassembling parts of the robot! See Cut the paint or surface on the robot before replacing parts on page 124 .	

Removing the axis-2 motor





	Action	Note
1	 DANGER Make sure that all supplies for electrical power, hydraulic pressure, and air pressure are turned off.	
2	 CAUTION For robots with protection type Clean Room Always cut the paint with a knife and grind the paint edge when disassembling parts of the robot! See Cut the paint or surface on the robot before replacing parts on page 124 .	
3	 CAUTION Removing motors will release axes. This means the axes can fall down. Make sure axes are well supported before removing motors.	

Continues on next page

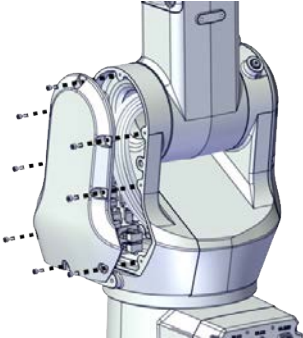

5 Repair

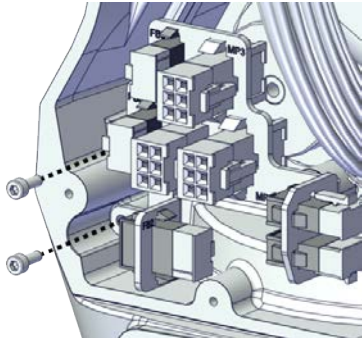
5.5.1 Replacing the lower arm

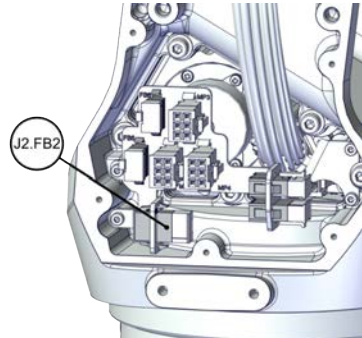
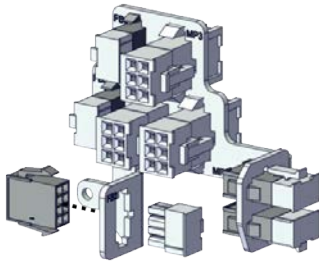
Continued

	Action	Note
4	Remove the swing support cover.	 xx1800002488
5	Remove the connector plate.  CAUTION Be aware of the cablings that are attached to the connector plate! The connector plate cannot be removed completely until the connectors are removed from the plate.	 xx1800002489
6	Disconnect the connector. • J2.FB2  Tip Take photos of the connector and cable position before disconnecting them, to have as a reference when reconnecting.	 xx1800002490
7	Snap loose and remove the female head of the connector from the connector plate.	 xx1800002491

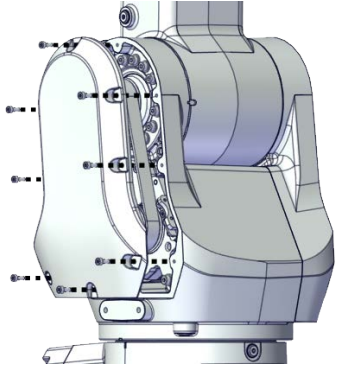
Continues on next page

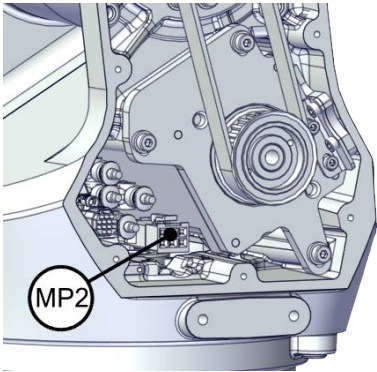
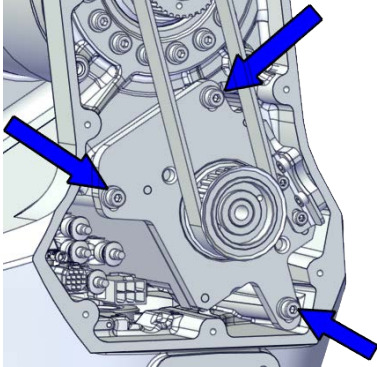
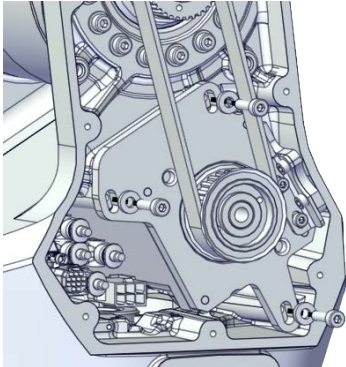

	Action	Note
8	Remove the swing cover.	 <p>xx1800002492</p>
9	Disconnect the connector. <ul style="list-style-type: none"> • MP2  Tip Take photos of the connector and cable position before disconnecting them, to have as a reference when reconnecting.	 <p>xx1800002495</p>
10	Loosen the screws and move the motor slightly to slacken the timing belt.	 <p>xx1800002493</p>
11	Remove the screws and washers.	 <p>xx1800002494</p>

Continues on next page



5 Repair

5.5.1 Replacing the lower arm

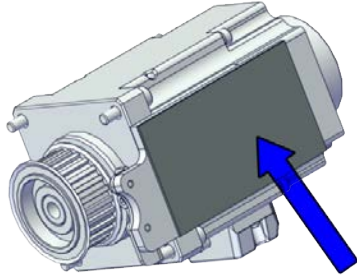
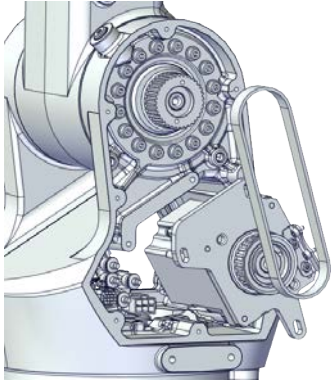
Continued

	Action	Note
12	<p>Carefully lift out the motor.</p> <p> CAUTION</p> <p>A cooling pad is attached to the motor, which may stick to the casting. Always use a plastic sheet with caution to remove the pad from the casting. Pay attention not to scratch the casting or damage the pad.</p> <p> CAUTION</p> <p>Be aware of the motor cabling. The motor cannot be removed completely until the connector is disconnected, as shown in following step.</p>	<p>Cooling pad location</p>  <p>xx1800003603</p>
13	<p>Remove the timing belt from its groove on the motor.</p>	 <p>xx1800002496</p>



Disconnecting the connectors at the division point

	Action	Note
1	<p> DANGER</p> <p>Make sure that all supplies for electrical power, hydraulic pressure, and air pressure are turned off.</p>	
2	<p> CAUTION</p> <p>For robots with protection type Clean Room</p> <p>Always cut the paint with a knife and grind the paint edge when disassembling parts of the robot! See Cut the paint or surface on the robot before replacing parts on page 124.</p>	

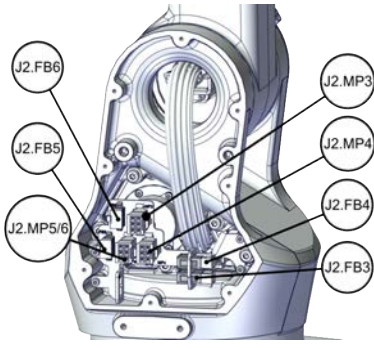
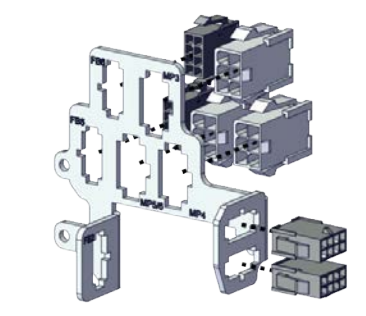
Continues on next page

	Action	Note
3	<p>Disconnect the connectors.</p> <ul style="list-style-type: none"> • J2.FB3,4,5,6 • J2.MP3,4,5/6 <p> Tip</p> <p>Take photos of the connector and cable position before disconnecting them, to have as a reference when reconnecting.</p>	 <p>xx1800002497</p>
4	<p>Snap loose and remove the female head of the connectors from the connector plate.</p>	 <p>xx1800002498</p>

Separating the cable package from the swing

	Action	Note
1	<p> DANGER</p> <p>Make sure that all supplies for electrical power, hydraulic pressure, and air pressure are turned off.</p>	
2	<p> CAUTION</p> <p>For robots with protection type Clean Room</p> <p>Always cut the paint with a knife and grind the paint edge when disassembling parts of the robot! See Cut the paint or surface on the robot before replacing parts on page 124.</p>	

Continues on next page



5 Repair

5.5.1 Replacing the lower arm

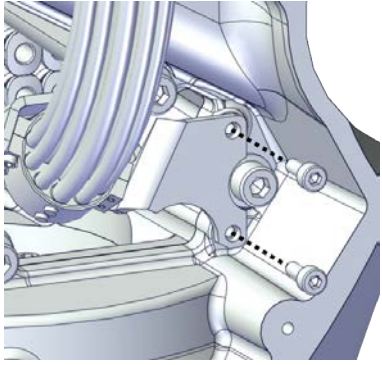
Continued

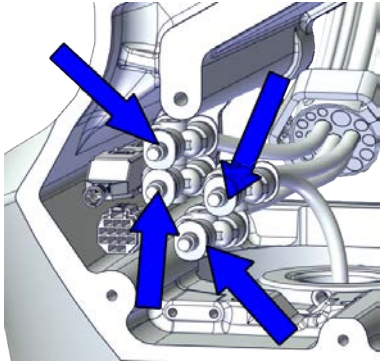

	Action	Note
3	Remove the cable bracket.	 <p>xx1800002499</p>

Disconnecting the air hoses, CP/CS cabling and Ethernet cabling (if equipped)



	Action	Note
1	 DANGER Make sure that all supplies for electrical power, hydraulic pressure, and air pressure are turned off.	
2	 CAUTION For robots with protection type Clean Room Always cut the paint with a knife and grind the paint edge when disassembling parts of the robot! See Cut the paint or surface on the robot before replacing parts on page 124 .	
3	Disconnect the air hoses from the Y-shaped connectors.	 <p>xx1800002500</p>

Continues on next page

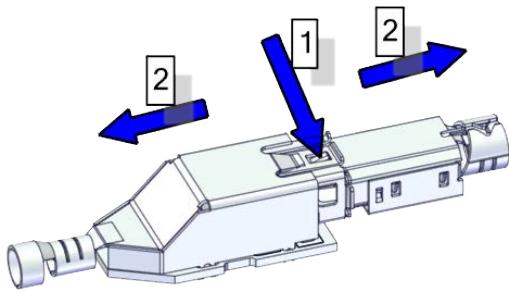
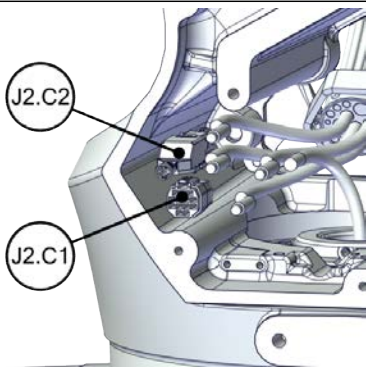
5.5.1 Replacing the lower arm
Continued

	Action	Note
4	<p>Disconnect the connectors.</p> <ul style="list-style-type: none"> • J2.C1 • J2.C2 <p> Tip</p> <p>Take photos of the connector and cable position before disconnecting them, to have as a reference when reconnecting.</p> <p> Tip</p> <p>The connector clip has to be pressed (1) and pushed forward (2) to separate the J2.C2 (for Ethernet cabling).</p>  <p>xx1800002943</p>	 <p>xx1800002501</p>

Separating the upper cable harness from the axis-2 gearbox

	Action	Note
1	<p> DANGER</p> <p>Make sure that all supplies for electrical power, hydraulic pressure, and air pressure are turned off.</p>	
2	<p> CAUTION</p> <p>For robots with protection type Clean Room</p> <p>Always cut the paint with a knife and grind the paint edge when disassembling parts of the robot! See Cut the paint or surface on the robot before replacing parts on page 124.</p>	

Continues on next page



5 Repair

5.5.1 Replacing the lower arm

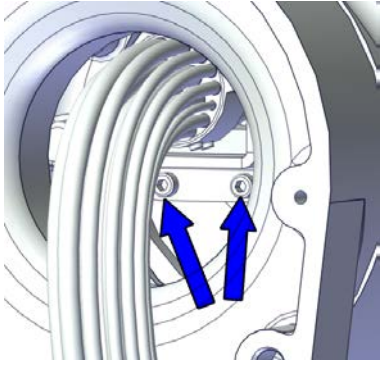

Continued

	Action	Note
3	Remove the cable bracket.	 <p>xx1800003002</p>

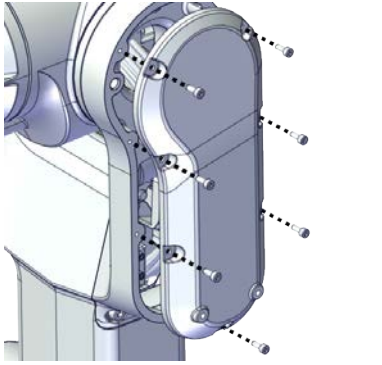
Disconnecting the axis-3 motor connectors

	Action	Note
1	 DANGER Make sure that all supplies for electrical power, hydraulic pressure, and air pressure are turned off.	
2	 CAUTION For robots with protection type Clean Room Always cut the paint with a knife and grind the paint edge when disassembling parts of the robot! See Cut the paint or surface on the robot before replacing parts on page 124 .	
3	Remove the lower arm support cover.	 <p>xx1800003003</p>

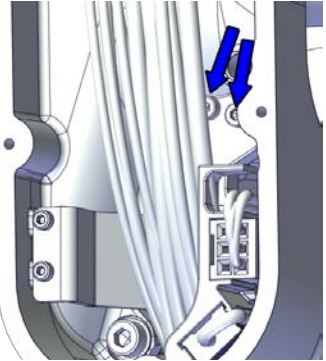
Continues on next page

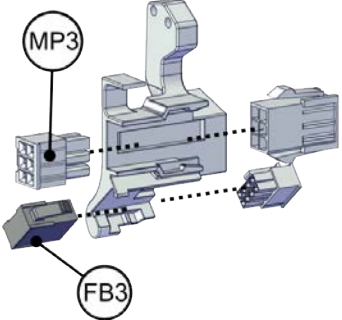
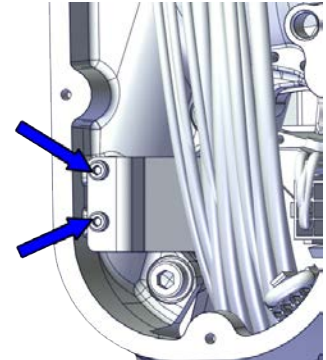
	Action	Note
4	<p>Remove the connector plate.</p> <p> CAUTION</p> <p>Be aware of the cabling that are attached to the connector plate! The connector plate cannot be removed completely until the connectors are removed from the plate, as shown in following step.</p>	 <p>xx1800003004</p>
5	<p>Slide the connectors out of the connector plate and disconnect the connectors.</p> <ul style="list-style-type: none"> • FB3 • MP3 <p> Tip</p> <p>Take photos of the connector and cable position before disconnecting them, to have as a reference when reconnecting.</p>	 <p>xx1800003005</p>
6	<p>Remove the cable bracket.</p>	 <p>xx1800003006</p>



Removing the axis-3 motor

	Action	Note
1	<p> DANGER</p> <p>Make sure that all supplies for electrical power, hydraulic pressure, and air pressure are turned off.</p>	

5 Repair

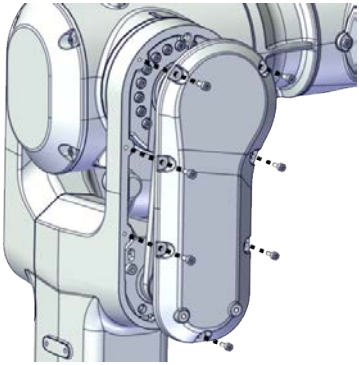
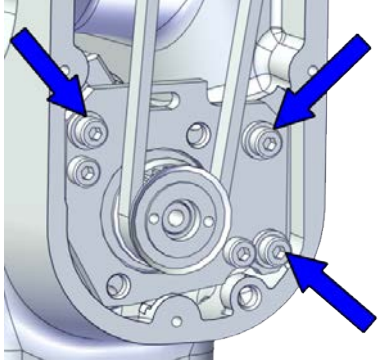

5.5.1 Replacing the lower arm

Continued

	Action	Note
2	 CAUTION For robots with protection type Clean Room Always cut the paint with a knife and grind the paint edge when disassembling parts of the robot! See <i>Cut the paint or surface on the robot before replacing parts on page 124.</i>	
3	 CAUTION Removing motors will release axes. This means the axes can fall down. Make sure axes are well supported before removing motors.	
4	Remove the lower arm cover.	 xx1800003007
5	Loosen the screws and move the motor slightly to slacken the timing belt.	 xx1800003008

Continues on next page

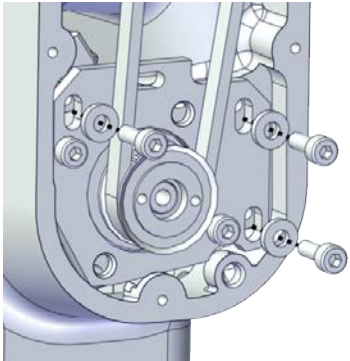
5.5.1 Replacing the lower arm
Continued

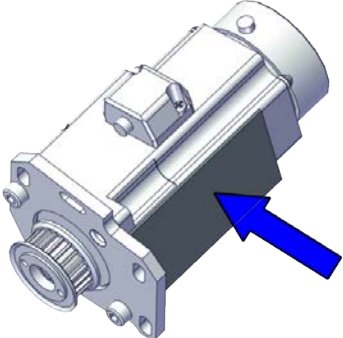
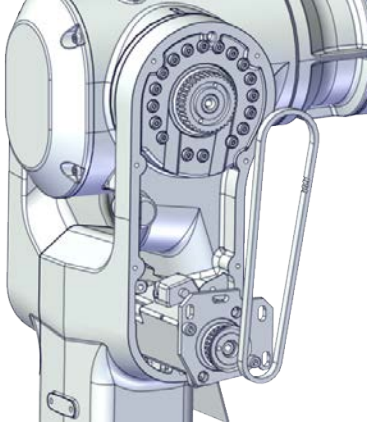
	Action	Note
6	Remove the screws and washers.	 <p>xx1800003009</p>
7	<p>Carefully lift out the motor.</p> <p> CAUTION</p> <p>A cooling pad is attached to the motor, which may stick to the casting. Always use a plastic sheet with caution to remove the pad from the casting. Pay attention not to scratch the casting or damage the pad.</p>	<p>Cooling pad location</p>  <p>xx1800003604</p>
8	Remove the timing belt from its groove on the motor.	 <p>xx1800003010</p>

Removing the swing support



	Action	Note
1	<p> DANGER</p> <p>Make sure that all supplies for electrical power, hydraulic pressure, and air pressure are turned off.</p>	

Continues on next page

5 Repair

5.5.1 Replacing the lower arm



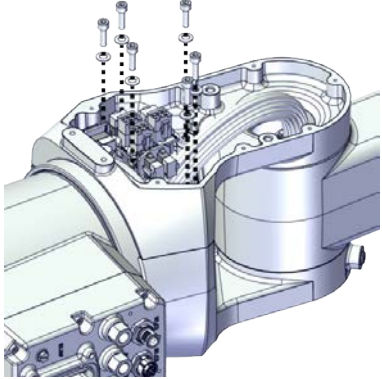
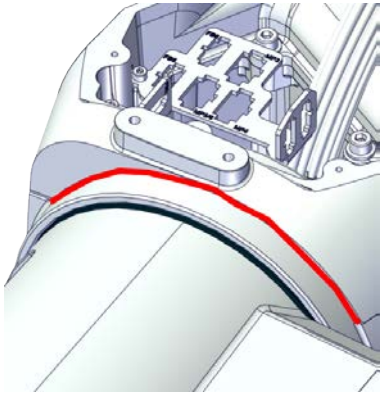

Continued

	Action	Note
2	<p> CAUTION</p> <p>For robots with protection type Clean Room Always cut the paint with a knife and grind the paint edge when disassembling parts of the robot! See <i>Cut the paint or surface on the robot before replacing parts on page 124.</i></p>	
3	<p>Remove the swing support.</p> <p> Note</p> <p>For Clean Room robots, the swing support is sealed with sealant (marked red in the figure). Always remove swing support carefully.</p> <p> Tip</p> <p>If the swing support is hard to loosen from the lower arm, use a plastic hammer to knock on the swing support lightly.</p>	 <p>xx1800003079</p>  <p>xx2000000321</p>
4	Route the upper cable package out of the swing support.	

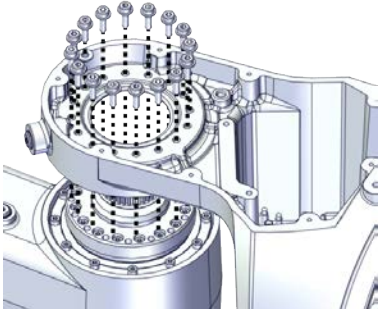

Separating the swing from the lower arm

	Action	Note
1	<p> DANGER</p> <p>Make sure that all supplies for electrical power, hydraulic pressure, and air pressure are turned off.</p>	

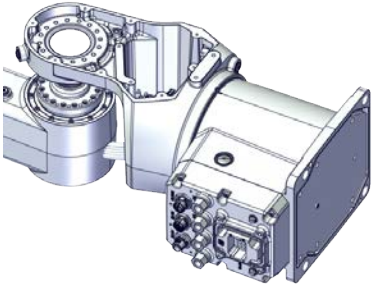
Continues on next page

	Action	Note
2	<p> CAUTION</p> <p>For robots with protection type Clean Room Always cut the paint with a knife and grind the paint edge when disassembling parts of the robot! See Cut the paint or surface on the robot before replacing parts on page 124.</p>	
3	<p>Remove the screws.</p> <p> Note</p> <p>Some robots may be fitted with separate screws and washers. During replacement, always use the same screws (and washers) that are fitted on the robot at delivery. Contact ABB for more information.</p>	 <p>xx1900002203</p>
4	<p>Separate the swing from the lower arm.</p> <p> Tip</p> <p>If the swing is hard to loosen from the housing, use a plastic hammer to knock on the swing lightly.</p>	 <p>xx1800003081</p>

Removing the axis-2 gearbox

	Action	Note
1	<p> DANGER</p> <p>Make sure that all supplies for electrical power, hydraulic pressure, and air pressure are turned off.</p>	
2	<p> CAUTION</p> <p>For robots with protection type Clean Room Always cut the paint with a knife and grind the paint edge when disassembling parts of the robot! See Cut the paint or surface on the robot before replacing parts on page 124.</p>	

Continues on next page



5 Repair

5.5.1 Replacing the lower arm

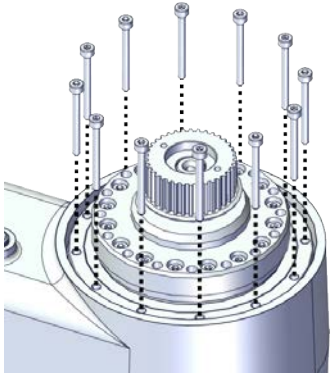
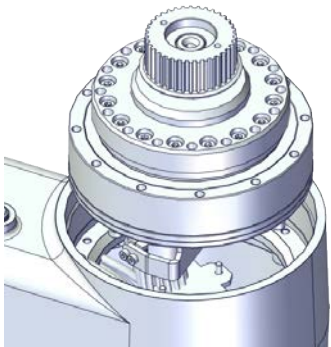
Continued

	Action	Note
3	 CAUTION Removing gearboxes will release axes. This means the axes can fall down. Make sure axes are well supported before removing gearboxes.	
4	Remove the screws.	 xx1800003082
5	Pull out the gearbox.	 xx1800003083

Pulling out the upper cable package



	Action	Note
1	 DANGER Make sure that all supplies for electrical power, hydraulic pressure, and air pressure are turned off.	
2	 CAUTION For robots with protection type Clean Room Always cut the paint with a knife and grind the paint edge when disassembling parts of the robot! See Cut the paint or surface on the robot before replacing parts on page 124.	

Continues on next page

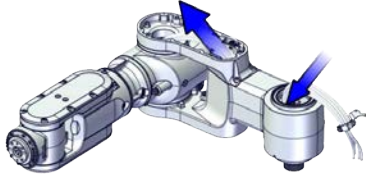
5.5.1 Replacing the lower arm
Continued

	Action	Note
3	Pull out the upper cable harness upwards from the lower arm support.	 <p>xx1800003086</p>

Removing the lower arm support

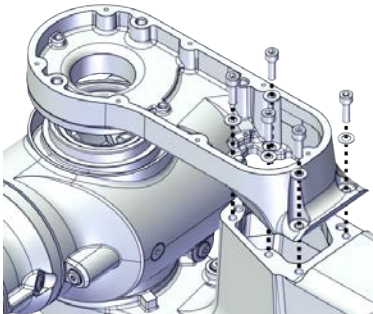
	Action	Note
1	 DANGER Make sure that all supplies for electrical power, hydraulic pressure, and air pressure are turned off.	
2	 CAUTION For robots with protection type Clean Room Always cut the paint with a knife and grind the paint edge when disassembling parts of the robot! See Cut the paint or surface on the robot before replacing parts on page 124 .	
3	Remove the lower arm support.  Tip If the lower arm support is hard to loosen from the housing, use a plastic hammer to knock on the lower arm support lightly.	 <p>xx1800003088</p>

Separating the lower arm from the housing





	Action	Note
1	 DANGER Make sure that all supplies for electrical power, hydraulic pressure, and air pressure are turned off.	

Continues on next page

5 Repair

5.5.1 Replacing the lower arm

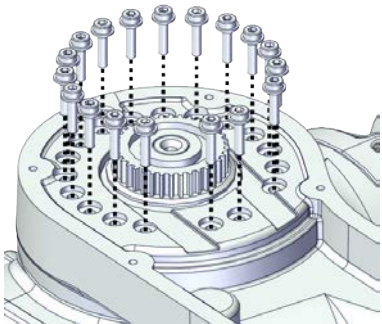
Continued

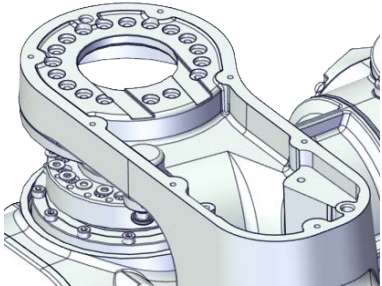
	Action	Note
2	 CAUTION For robots with protection type Clean Room Always cut the paint with a knife and grind the paint edge when disassembling parts of the robot! See <i>Cut the paint or surface on the robot before replacing parts on page 124.</i>	
3	Remove the screws.  Note Some robots may be fitted with separate screws and washers. During replacement, always use the same screws (and washers) that are fitted on the robot at delivery. Contact ABB for more information.	 xx1900002190
4	Separate the lower arm from the housing.  Tip If the lower arm is hard to loosen from the housing, use a plastic hammer to knock on the lower arm lightly.	 xx1800003090

Refitting the lower arm

Use these procedures to refit the lower arm.

Refitting the lower arm to the housing

	Action	Note
1	For robots with protection type Clean Room: Clean the joints that have been opened and wipe the parts free from particles with spirit on a lint free.	

Continues on next page

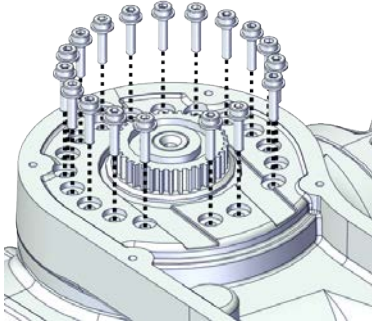
	Action	Note
2	<p>Refit the lower arm to the housing.</p> <p> Note</p> <p>Some robots may be fitted with separate screws and washers. During replacement, always use the same screws (and washers) that are fitted on the robot at delivery. Contact ABB for more information.</p>	<p>Flange screws (16 pcs)</p> <p>For robots with protection class IP40 Tightening torque: 1.9 Nm</p> <p>For robots with protection class IP67 Tightening torque: 1.8 Nm</p> <p>For robots with protection type Clean Room Tightening torque: 1.8 Nm</p>  <p>xx1900002190</p>

Checking the radial sealing on the lower arm support (IP67 or Clean Room)

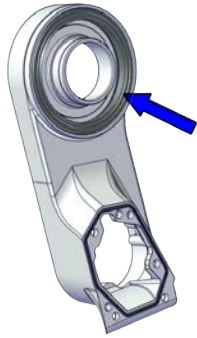

	Action	Note
1	<p>For robots with protection type Clean Room: Clean the joints that have been opened and wipe the parts free from particles with spirit on a lint free.</p>	
2	<p>Check the radial sealing on the lower arm support. Replace if damaged, as described below.</p>	 <p>xx1900002202</p>
3	<p>Apply a little grease to the new sealing when replacing the radial sealing and wipe clean after the replacement.</p>	<p>Grease: 3HAC029132-001</p>

Continues on next page

5 Repair

5.5.1 Replacing the lower arm

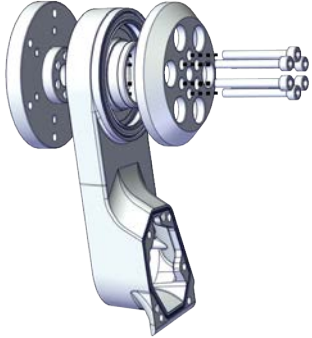
Continued

	Action	Note
4	Place the new sealing in its groove in the lower arm support.	 xx1900002160
5	Place the dish-shaped plate of the radial sealing fitting tool against the radial sealing.	Axis-3 radial sealing assembly tool, included in the radial sealing assembly tool set 3HAC074609-001.  xx1900002161
6	Fit the circular plate to the other side of the lower arm support with six M6x50 screws.	
7	Screw the screws, little by little, to press the sealing into place.	 xx1900002162
8	Remove the assembly tool.	
9	Check that the sealing is undamaged and properly fitted.	

Securing the lower arm support

	Action	Note
1	For robots with protection type Clean Room: Clean the joints that have been opened and wipe the parts free from particles with spirit on a lint free.	

Continues on next page

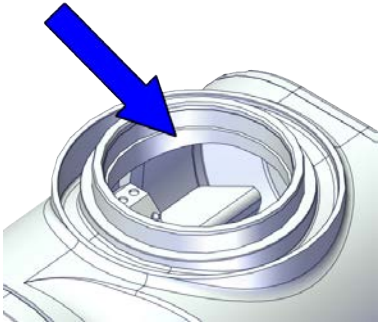
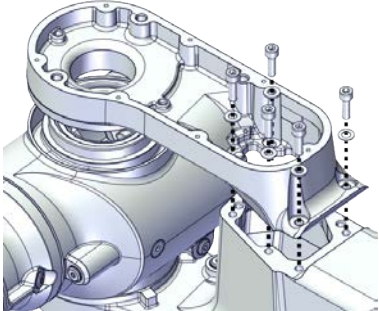
	Action	Note
2	Apply grease Castrol Molub-Alloy 777-1 NG to the inner surface of the housing, where contacts the bearing on the lower arm support.	 <p>xx2000000059</p>
3	Refit the lower arm support.	<p>Screw: M5x16 12.9 Lafre 2C2B/FC6.9 (5 pcs) Tightening torque: 8 Nm</p>  <p>xx1800003088</p>
4	Route the cable package through the lower arm support.	

Refitting the axis-2 gearbox

	Action	Note
1	For robots with protection type Clean Room: Clean the joints that have been opened and wipe the parts free from particles with spirit on a lint free.	

5 Repair

5.5.1 Replacing the lower arm

Continued

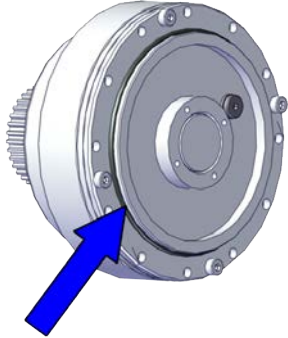
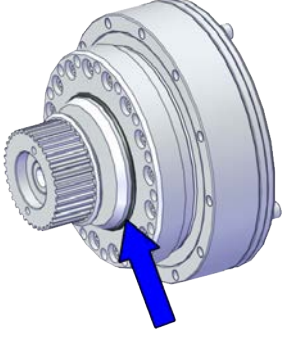
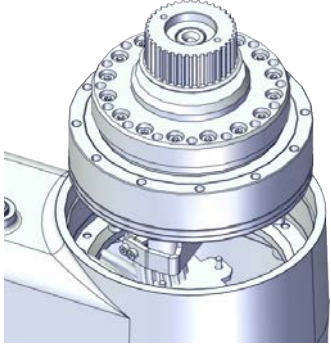
	Action	Note
2	<p>For robots with protection class IP67 (option 3350-670) For robots with protection type Clean Room (option 3351-4) Check the O-rings. Replace if damaged.</p>	<p>O-ring on flexible spline side: 3HAB3772-182</p>  <p>xx1900002195</p> <p>O-ring on circular spline side: 3HAB3772-143</p>  <p>xx1900002194</p>
3	Refit the axis-2 gearbox.	 <p>xx1800003083</p>

Continues on next page

5.5.1 Replacing the lower arm
Continued

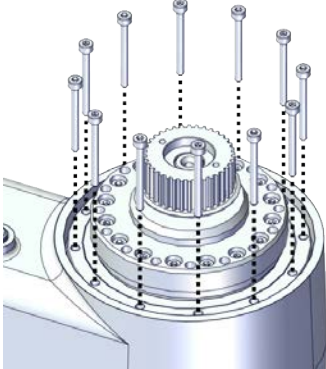
	Action	Note
4	Secure with screws.	<p>Screw: M3x30 12.9 Lafre 2C2B/FC6.9 (12 pcs) Tightening torque: 1.9 Nm</p>  <p>xx1800003082</p>

Refitting the swing to the lower arm

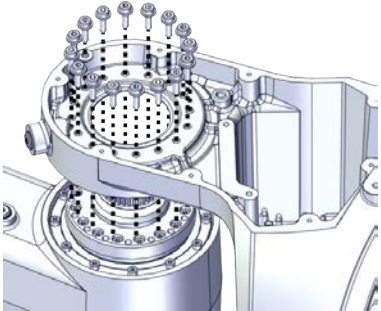
	Action	Note
1	For robots with protection type Clean Room: Clean the joints that have been opened and wipe the parts free from particles with spirit on a lint free.	
2	<p>Refit the swing to the lower arm.</p>  <p>Note</p> <p>Some robots may be fitted with separate screws and washers. During replacement, always use the same screws (and washers) that are fitted on the robot at delivery. Contact ABB for more information.</p>	<p>Flange screws (16 pcs) For robots with protection class IP40 Tightening torque: 4.2 Nm For robots with protection class IP67 For robots with protection type Clean Room Tightening torque: 4 Nm</p>  <p>xx1900002203</p>

Checking the radial sealing on the swing support (IP67 or Clean Room)

	Action	Note
1	For robots with protection type Clean Room: Clean the joints that have been opened and wipe the parts free from particles with spirit on a lint free.	

Continues on next page

5 Repair

5.5.1 Replacing the lower arm

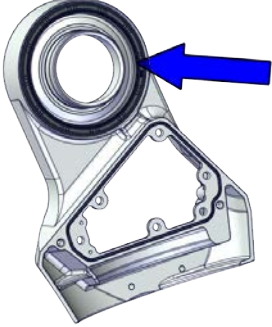
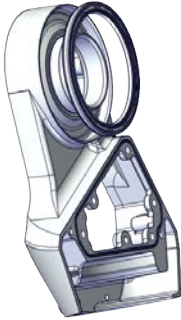
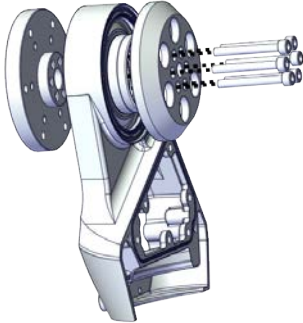

Continued

	Action	Note
2	Check the radial sealing on the swing support. Replace if damaged, as described below.	 <p>xx1900002201</p>
3	Apply a little grease to the new sealing when replacing the radial sealing and wipe clean after the replacement.	Grease: 3HAC029132-001
4	Place the new sealing in its groove in the swing support.	 <p>xx1900002157</p>
5	Place the dish-shaped plate of the radial sealing fitting tool against the radial sealing.	Axis-2 radial sealing assembly tool, included in the radial sealing assembly tool set 3HAC074609-001.
6	Fit the circular plate to the other side of the swing support with six M6x50 screws.	
		 <p>xx1900002158</p>

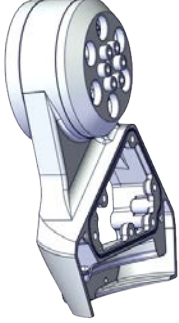
Continues on next page

	Action	Note
7	Screw the screws, little by little, to press the sealing into place.	 xx1900002159
8	Remove the assembly tool.	
9	Check that the sealing is undamaged and properly fitted.	

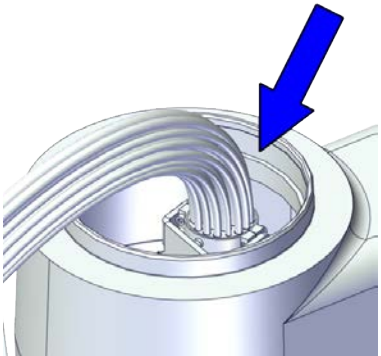
Securing the swing support

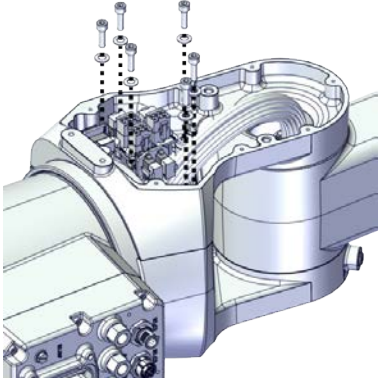
	Action	Note
1	For robots with protection type Clean Room: Clean the joints that have been opened and wipe the parts free from particles with spirit on a lint free.	
2	Apply grease Castrol Molub-Alloy 777-1 NG to the inner surface of the lower arm, where contacts the bearing on the swing support.	 xx2000000058
3	Refit the swing support.  Tip If the swing support is hard to closely fit to the lower arm, use a plastic hammer to knock on the swing support lightly.	Screw: M5x16 12.9 Lafre 2C2B/FC6.9 (6 pcs) Tightening torque: 6 Nm  xx1800003079

Continues on next page

5 Repair

5.5.1 Replacing the lower arm

Continued

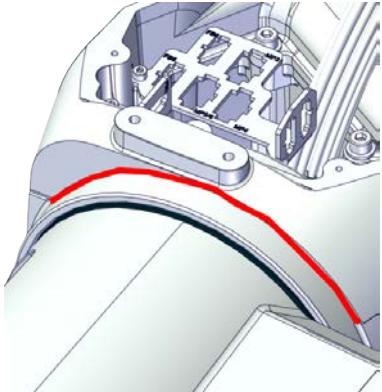
	Action	Note
4	<p>For robots with protection type Clean Room (option 3351-4)</p> <p>Apply a string of the sealant Sikaflex 521FC to the joint of the swing support. Smooth out the sealant string using a finger tip.</p> <p>Use washing-up on finger tips to get a smooth joint.</p> <p>If necessary, add extra sealant to get a full cover joint.</p>	 <p>xx2000000321</p>

Guiding the upper cable package down to the swing

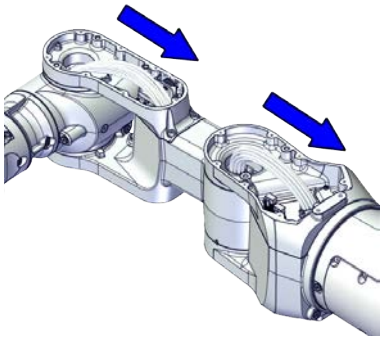
	Action	Note
1	<p>For robots with protection type Clean Room:</p> <p>Clean the joints that have been opened and wipe the parts free from particles with spirit on a lint free.</p>	
2	<p>Guide the upper cable package to go through the lower arm and down to the swing.</p> <p>When inserting the cable package, leave the axis-3 motor connectors in the lower arm.</p> <p> Tip</p> <p>Wrap the connectors with the masking tape.</p>	 <p>xx1800003091</p>



Refitting the axis-3 motor

	Action	Note
1	<p>For robots with protection type Clean Room:</p> <p>Clean the joints that have been opened and wipe the parts free from particles with spirit on a lint free.</p>	
2	<p>Check that:</p> <ul style="list-style-type: none"> • all assembly surfaces are clean and without damages • the motor is clean and undamaged. 	

Continues on next page

5.5.1 Replacing the lower arm

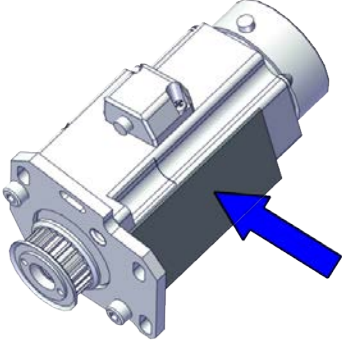
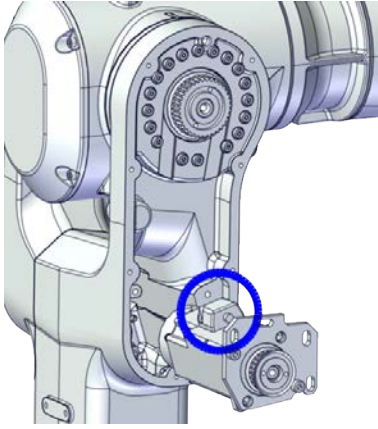
Continued

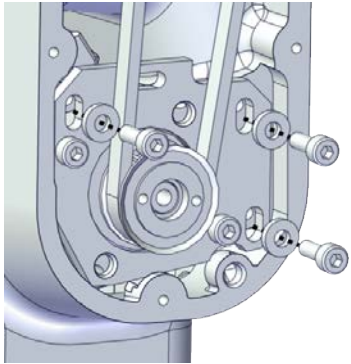

	Action	Note
3	<p>Check the cooling pad. Replace if damaged.</p>	<p>Cooling pad for axis-3 and -4 motors: 3HAC071021-001</p>  <p>xx1800003604</p>
4	<p>Orient the motor correctly and fit it into the lower arm.</p>	<p>Motor orientation: orient the motor according to the figure below, in regard to the encircled motor connector.</p>  <p>xx1800003021</p>
5	<p>Refit the screws and washers.</p> <p> Note</p> <p>Do not tighten the screws yet.</p>	<p>Screw: M4x12 12.9 Lafre 2C2B/FC6.9 (3 pcs) Washer, 3HAC063985-001 (3 pcs)</p>  <p>xx1800003009</p>

Continues on next page

5 Repair

5.5.1 Replacing the lower arm

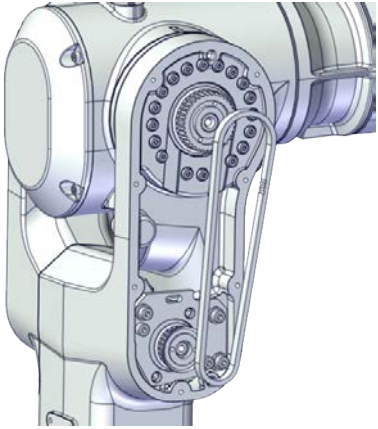
Continued

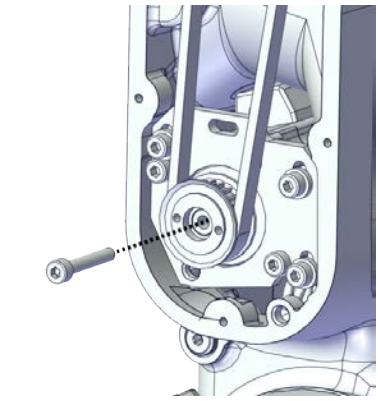
	Action	Note
6	Install the timing belt to the pulleys and verify that the belt runs correctly in the grooves of the pulleys.	 <p>xx1800003022</p>
7	Install an M4x25 or longer adjustment screw to the motor.  Note Do not insert the entire screw to the hole.	 <p>xx1900000009</p>

Continues on next page

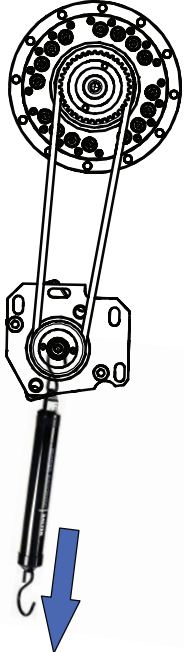
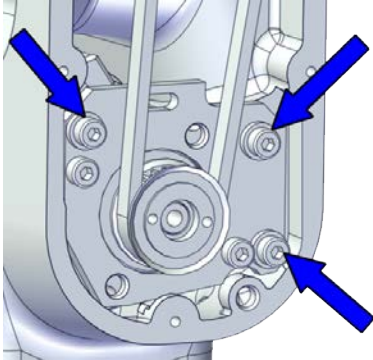
	Action	Note
8	Use a handheld dynamometer hooking to the screw and pull the dynamometer to reach the initial referenced force.	<p>Initial referenced force for used belt: 21.7-23.94 N (for reference only) Initial referenced force for new belt: 31-34.2 N</p>  <p>xx1900000028</p>
9	Secure the motor with the screws.	<p>Tightening torque: 3 Nm</p>  <p>xx1800003008</p>
10	Use a sonic tension meter to measure the timing belt tension.	<p>Used belt: 102-109 Hz New belt: 113-143 Hz (for reference only)</p>
11	If the timing belt tension does not meet the requirement, loosen the motor screws and readjust.	

Continues on next page



5 Repair

5.5.1 Replacing the lower arm

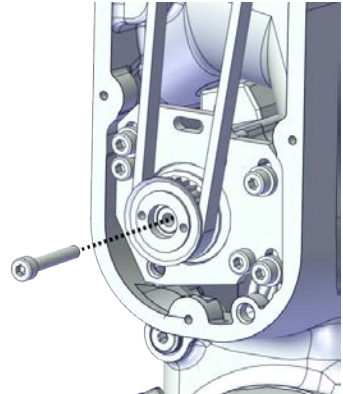
Continued

	Action	Note
12	Remove the adjustment screw from the motor.	 <p>xx1900000009</p>

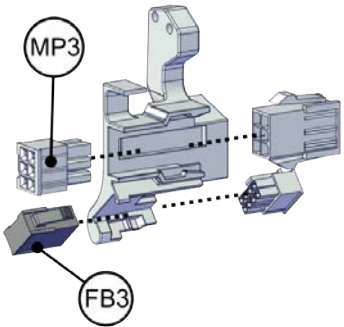
Reconnecting the axis-3 motor connectors

	Action	Note
1	For robots with protection type Clean Room: Clean the joints that have been opened and wipe the parts free from particles with spirit on a lint free.	
2	Slide the connectors into the connector plate and reconnect the connectors. <ul style="list-style-type: none"> • FB3 • MP3  Tip See the number markings on the connectors for help to find the corresponding connector.	 <p>xx1800003005</p>
3	Route and secure the cabling with cable straps.  CAUTION Correct cable routing is highly important. If the cables are routed and secured incorrectly the cables can be damaged.	

Continues on next page

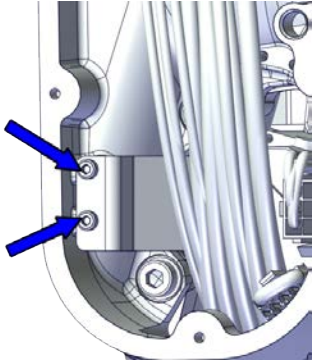
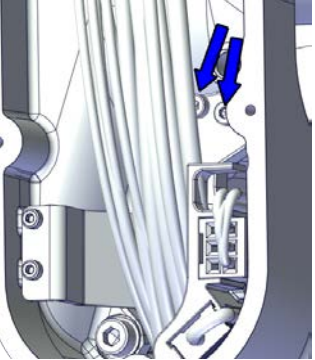
	Action	Note
4	Refit the cable bracket.	<p>Screw: M2.5x6 12.9 Lafre 2C2B/FC6.9 (2 pcs) Tightening torque: 0.6 Nm</p>  <p>xx1800003006</p>
5	Refit the connector plate.	<p>Screw: M3x12 12.9 Lafre 2C2B/FC6.9 (2 pcs) Tightening torque: 0.4 Nm</p>  <p>xx1800003004</p>

Securing the upper cable package to the axis-2 gearbox

	Action	Note
1	For robots with protection type Clean Room: Clean the joints that have been opened and wipe the parts free from particles with spirit on a lint free.	



5 Repair

5.5.1 Replacing the lower arm

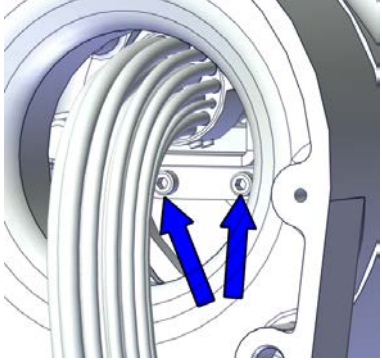
Continued

	Action	Note
2	Refit the cable bracket.	<p>Screw: M2.5x6 12.9 Lafre 2C2B/FC6.9 (2 pcs) Tightening torque: 0.6 Nm</p>  <p>xx1800003002</p>

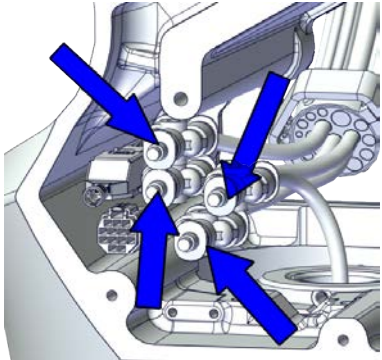
Reconnecting the air hoses, CP/CS cabling and Ethernet cabling (if equipped)

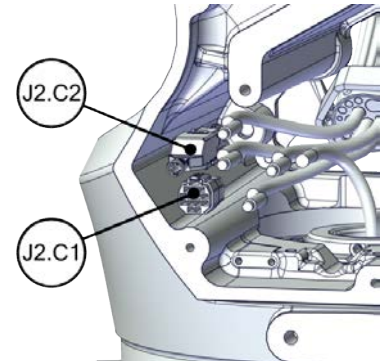
	Action	Note
1	For robots with protection type Clean Room: Clean the joints that have been opened and wipe the parts free from particles with spirit on a lint free.	
2	<p>Reconnect the air hoses in a cross pattern to the Y-shaped connectors.</p>  Tip See the number markings on the air hoses for help to find the corresponding air hoses. The air hoses with the same number connect to the same Y-shaped connector.	 <p>xx1800002500</p>
3	<p>Reconnect the connectors.</p> <ul style="list-style-type: none"> • J2.C1 • J2.C2  Tip See the number markings on the connectors for help to find the corresponding connector.	 <p>xx1800002501</p>

Continues on next page

Securing the cable package to the swing

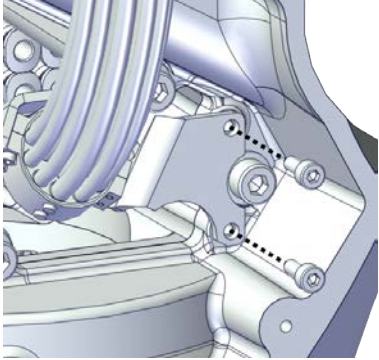
	Action	Note
1	For robots with protection type Clean Room: Clean the joints that have been opened and wipe the parts free from particles with spirit on a lint free.	
2	Refit the cable bracket.	<p>Screw: M3x8 12.9 Lafre 2C2B/FC6.9 (2 pcs) Tightening torque: 0.8 Nm</p>  <p>xx1800002499</p>

Refitting the axis-2 motor

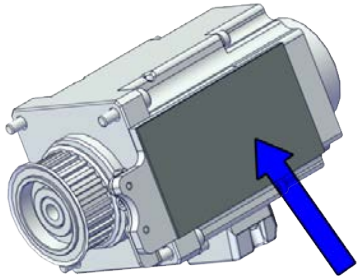



	Action	Note
1	For robots with protection type Clean Room: Clean the joints that have been opened and wipe the parts free from particles with spirit on a lint free.	
2	Check that: <ul style="list-style-type: none"> • all assembly surfaces are clean and without damages • the motor is clean and undamaged. 	
3	Check the cooling pad. Replace if damaged, as shown in the following step.	<p>Cooling pad for axis-1 and -2 motors: 3HAC071020-001</p>  <p>xx1800003603</p>

Continues on next page

5 Repair

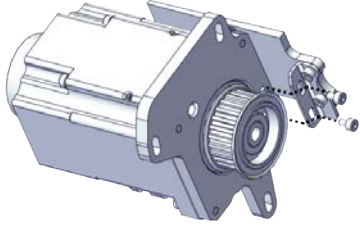

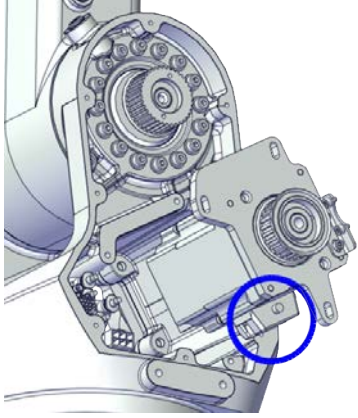
5.5.1 Replacing the lower arm

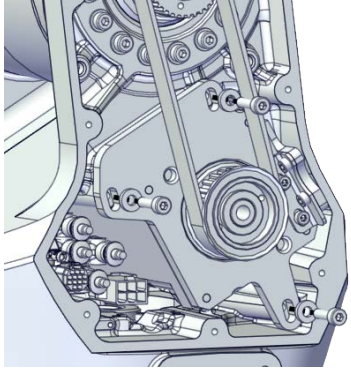
Continued

	Action	Note
4	<p>Remove the screws. Replace with a new cooling pad and then refit the screws.</p>	<p>Screw: M3x5 12.9 Lafre 2C2B/FC6.9 (2 pcs) Tightening torque: 1.2 Nm</p>  <p>xx1800003026</p>
5	<p>Orient the motor correctly and fit it into the swing.</p> <p> Tip</p> <p>Bend the motor signal cable back towards the swing support.</p>	<p>Motor orientation: orient the motor according to the figure below, in regard to the encircled motor connector.</p>  <p>xx1800003027</p>
6	<p>Refit the screws and washers.</p> <p> Note</p> <p>Do not tighten the screws yet.</p>	<p>Screw: M4x16 12.9 Lafre 2C2B/FC6.9 (3 pcs) Washer, 3HAC063985-001 (3 pcs)</p>  <p>xx1800002494</p>

Continues on next page

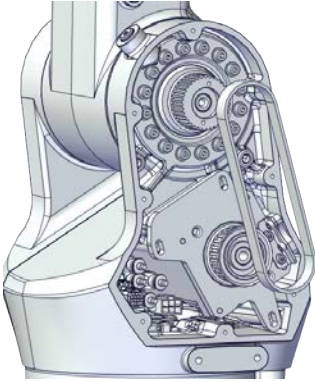
5.5.1 Replacing the lower arm
Continued

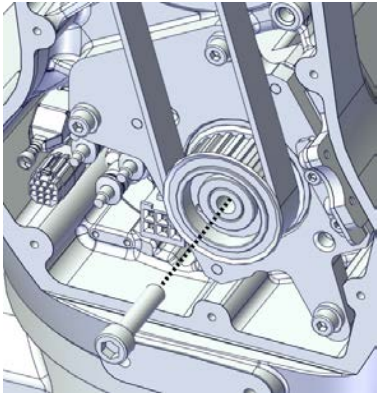
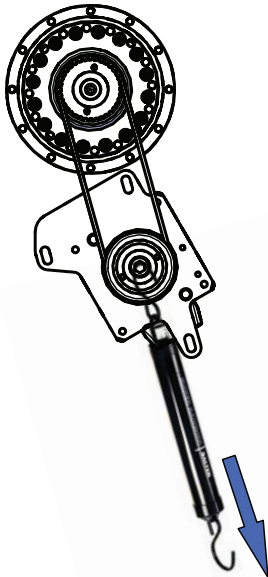

	Action	Note
7	Install the timing belt to the pulleys and verify that the belt runs correctly in the grooves of the pulleys.	 <p>xx1800003028</p>
8	Install an M6x25 or longer adjustment screw to the motor.  Note Do not insert the entire screw to the hole.	 <p>xx1900000010</p>
9	Use a handheld dynamometer hooking to the screw and pull the dynamometer to reach the initial referenced force.	Initial referenced force for used belt: 68.18-75.04 N (for reference only) Initial referenced force for new belt: 97.4-107.2 N  <p>xx1900000029</p>

Continues on next page

5 Repair



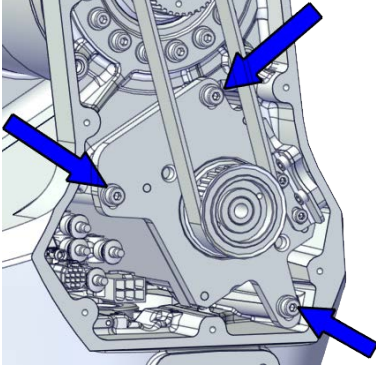
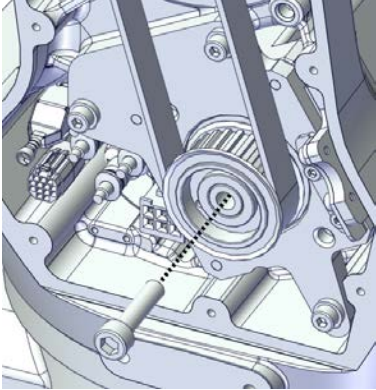

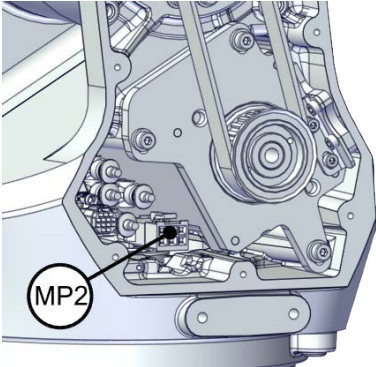
5.5.1 Replacing the lower arm

Continued

	Action	Note
10	Secure the motor with the screws.	<p>Tightening torque: 3.5 Nm</p>  <p>xx1800002493</p>
11	Use a sonic tension meter to measure the timing belt tension.	<p>Used belt: 163-174 Hz New belt: 180-229 Hz (for reference only)</p>
12	If the timing belt tension does not meet the requirement, loosen the motor screws and readjust.	
13	Remove the adjustment screw from the motor.	 <p>xx1900000010</p>
14	<p>Reconnect the connector.</p> <ul style="list-style-type: none"> • MP2 <p> Tip</p> <p>See the number markings on the connectors for help to find the corresponding connector.</p>	 <p>xx1800002495</p>

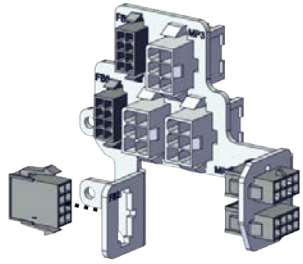
Continues on next page

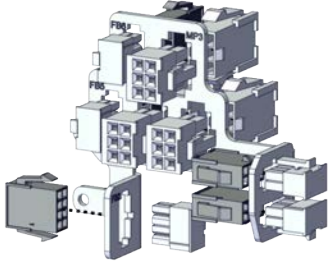
Reconnecting the connectors at the division point

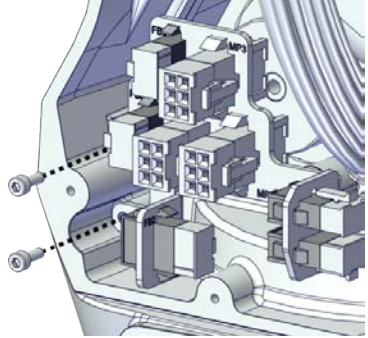
	Action	Note
1	<p>For robots with protection type Clean Room: Clean the joints that have been opened and wipe the parts free from particles with spirit on a lint free.</p>	
2	<p>Insert the female header of the connectors to the connector plate.</p>	 <p>xx1800003029</p>
3	<p>Reconnect the connectors.</p> <ul style="list-style-type: none"> • J2.FB2,3,4,5,6 • J2.MP3,4,5/6 <p> Tip</p> <p>See the number markings on the connectors for help to find the corresponding connector.</p>	 <p>xx1800003030</p>
4	<p>Route and secure the cabling with cable straps.</p> <p> CAUTION</p> <p>Correct cable routing is highly important. If the cables are routed and secured incorrectly the cables can be damaged.</p>	
5	<p>Refit the connector plate.</p>	<p>Screw: M3x8 12.9 Lafre 2C2B/FC6.9 (2 pcs) Tightening torque: 0.8 Nm</p>  <p>xx1800002489</p>

Continues on next page

5 Repair

5.5.1 Replacing the lower arm

Continued

Refitting the covers

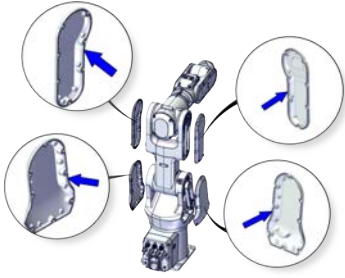
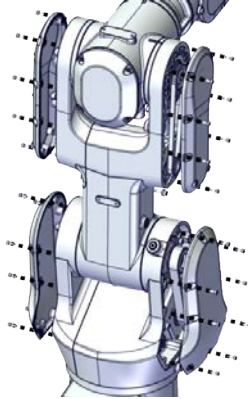
	Action	Note
1	For robots with protection type Clean Room: Clean the joints that have been opened and wipe the parts free from particles with spirit on a lint free.	
2	For robots with protection class IP67 (option 3350-670) For robots with protection type Clean Room (option 3351-4) Check the gaskets. Replace if damaged.	 xx1900002176
3	Apply grease to the cable package, cover all moving area of the package.	
4	Apply grease to the covers that have contacting area with the cable package.	
5	Refit the covers. <ul style="list-style-type: none"> • Lower arm cover • Lower arm support cover • Swing cover • Swing support cover 	Screw: M3x8 12.9 Lafre 2C2B/FC6.9 Tightening torque: 1.2 Nm  xx1800003610

Concluding procedure

	Action	Note
1	For robots with protection type Clean Room: Clean and paint the joints that have been opened. See Cut the paint or surface on the robot before replacing parts on page 124.	
	 Note After all repair work, wipe the Clean Room robot free from particles with spirit on a lint free cloth.	
2	Recalibrate the robot.	Calibration is detailed in section Calibration on page 685.

Continues on next page

	Action	Note
3	 DANGER Make sure all safety requirements are met when performing the first test run. See Test run after installation, maintenance, or repair on page 91 .	

5 Repair

5.6.1 Replacing the housing

5.6 Housing, extender unit and wrist

5.6.1 Replacing the housing

Location of the housing

The housing is located as shown in the figure.

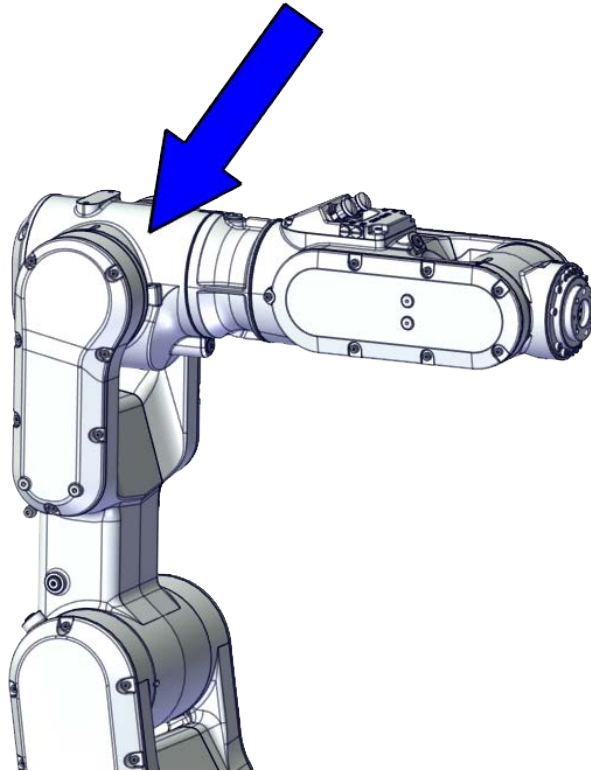

xx1800002475

Required spare parts



Note

The spare part numbers that are listed in the table can be out of date. See the latest spare parts of the IRB 1100 via myABB Business Portal, www.abb.com/myABB.

Spare part	Article number	Note
Process hub, basic	3HAC069094-001	
Process hub, basic, Clean Room	3HAC075509-001	Used with protection type Clean Room.
Process hub (CP/CS and air hose, without Ethernet)	3HAC069095-001	
Process hub, Clean Room (CP/CS and air hose, without Ethernet)	3HAC075510-001	Used with protection type Clean Room.
Process hub (CP/CS and air hose, with Ethernet)	3HAC069096-001	

Continues on next page

5.6.1 Replacing the housing
Continued

Spare part	Article number	Note
Process hub, Clean Room (CP/CS and air hose, with Ethernet)	3HAC075511-001	Used with protection type Clean Room.
Housing	3HAC069053-001	
Housing with sealing ring	3HAC074272-001	Used with protection class IP67.
Housing, Clean Room	3HAC075489-001	Used with protection type Clean Room.
Gear unit with pulley, axis 3	3HAC073518-001	
Labyrinth sealing ring	3HAC073218-001	
O-ring on circular spline side	3HAC061327-009	Used with protection class IP67 and protection type Clean Room. Replace if damaged.
O-ring on flexible spline side	3HAC061327-008	Used with protection class IP67 and protection type Clean Room. Replace if damaged.
Axis-3 radial sealing	3HAB3701-57	Used with protection class IP67 and protection type Clean Room. Replace if damaged.
Timing belt, axis 3	3HAC061936-001	
Motor with flange, axis 4	3HAC083586-001	
Timing belt, axis 4	3HAC061937-001	
Motor with flange, axis 6	3HAC083584-001	
Timing belt, axis 6	3HAC061939-001	
Housing cover	3HAC069054-001	
Housing cover, Clean Room	3HAC075501-001	Used with protection type Clean Room.
Wrist cover	3HAC069061-001	
Wrist cover, Clean Room	3HAC075507-001	Used with protection type Clean Room.
Gasket for housing cover	3HAC061959-007	Used with protection class IP67 and protection type Clean Room. Replace if damaged.
Gasket for wrist cover	3HAC061959-009	Used with protection class IP67 and protection type Clean Room. Replace if damaged.
Gasket for process hub	3HAC065352-001	Used with protection class IP67 and protection type Clean Room. Replace if damaged.
Cooling pad for axis-3 and -4 motors	3HAC071021-001	Cooling pads are wear parts. One cooling pad sheet includes 10 pieces of small pad. Replace if damaged with one piece each time.
Washer	3HAC063985-001	9x4.3x1, Steel
Washer	3HAC064765-001	7x3.2x1.5, Steel

Continues on next page

5 Repair

5.6.1 Replacing the housing

Continued

Spare part	Article number	Note
Rubber sealing washer on housing	3HAC064147-001	Used with protection class IP67 and protection type Clean Room. Replace if damaged.
Rubber sealing washer on extender unit	3HAC067995-001	Used with protection class IP67 and protection type Clean Room. Replace if damaged.
Plug screw	3HAC064146-001	Used with protection classes IP40 and IP67. Replace if damaged.
Plug screw, Clean Room	3HAC070309-001	Used with protection type Clean Room. Replace if damaged.

Required tools and equipment

Equipment	Article number	Note
Standard toolkit	-	Content is defined in section Standard toolkit on page 733 .
Calibration tool box, Axis Calibration	3HAC074119-001	Delivered as a set of calibration tools. Required if Axis Calibration is the valid calibration method for the robot. The tool box also includes a unique calibration pin for IRB 1100 to be fitted to the tool flange during calibration of axis 6.
24 VDC power supply	-	Used to release the motor brakes.
Sonic tension meter	-	Used for measuring the timing belt tension.
Dynamometer	-	Used for measuring the timing belt tension.
M3x25 eye bolt	-	Included in the special toolkit 3HAC071022-001.
axis-4 motor fitting tool	-	Included in the special toolkit 3HAC071022-001. Used to refit the axis-4 motor.

Required consumables

Consumable	Article number	Note
Cable straps	-	
Grease	3HAC029132-001	FM 222
Grease	-	Castrol Molub. Alloy 777-1 NG
Locking liquid	-	Loctite 2400 (or equivalent Loctite 243)

Continues on next page

Deciding calibration routine

Decide which calibration routine to be used, based on the information in the table. Depending on which routine is chosen, action might be required prior to beginning the repair work of the robot, see the table.

	Action	Note
1	Decide which calibration routine to use for calibrating the robot. <ul style="list-style-type: none"> Reference calibration. External cable packages (DressPack) and tools can stay fitted on the robot. Fine calibration. All external cable packages (DressPack) and tools must be removed from the robot. 	 Note Calibrating axis 6 always requires tools to be removed from the mounting flange (also for reference calibration) since the mounting flange is used for installation of the calibration tool.
	If the robot is to be calibrated with reference calibration: Find previous reference values for the axis or create new reference values. These values are to be used after the repair procedure is completed, for calibration of the robot. If no previous reference values exist, and no new reference values can be created, then reference calibration is not possible.	Follow the instructions given in the reference calibration routine on the FlexPendant to create reference values. Creating new values requires possibility to move the robot. Read more about reference calibration for Axis Calibration in Reference calibration routine on page 696 .
	If the robot is to be calibrated with fine calibration: Remove all external cable packages (DressPack) and tools from the robot.	

Removing the housing

Use these procedures to remove the housing.

Preparations before removing the housing

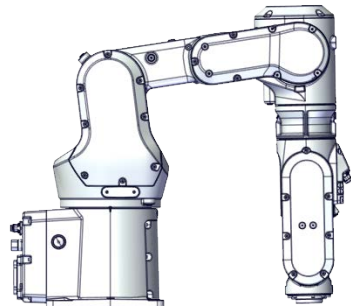

	Action	Note
1	Decide which calibration routine to use, and take actions accordingly prior to beginning the repair procedure.	
2	Jog the robot to the specified position: <ul style="list-style-type: none"> Axis 1: 0° Axis 2: 110° (IRB 1100-4/0.475) /95° (IRB 1100-4/0.58) Axis 3: -20° (IRB 1100-4/0.475)/ -6° (IRB 1100-4/0.58) Axis 4: 0° Axis 5: 0° Axis 6: No significance. 	 xx1800003289

Continues on next page



5 Repair

5.6.1 Replacing the housing

Continued

	Action	Note
3	 DANGER Turn off all: <ul style="list-style-type: none"> • electric power supply • hydraulic pressure supply • air pressure supply to the robot, before entering the safeguarded space.	
4	 CAUTION For robots with protection type Clean Room Always cut the paint with a knife and grind the paint edge when disassembling parts of the robot! See Cut the paint or surface on the robot before replacing parts on page 124 .	

Removing the process hub

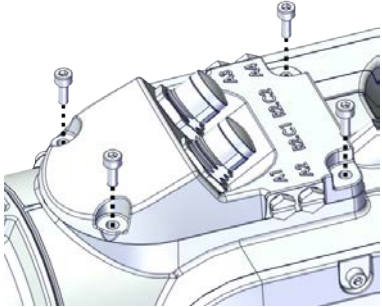
	Action	Note
1	 DANGER Make sure that all supplies for electrical power, hydraulic pressure, and air pressure are turned off.	
2	 CAUTION For robots with protection type Clean Room Always cut the paint with a knife and grind the paint edge when disassembling parts of the robot! See Cut the paint or surface on the robot before replacing parts on page 124 .	
3	Remove the screws and carefully open the cover.  CAUTION Be aware of the cabling that is attached to the cover! The cover can not be removed completely until the connectors are disconnected, as shown in following steps.	 xx1800002944

Continues on next page

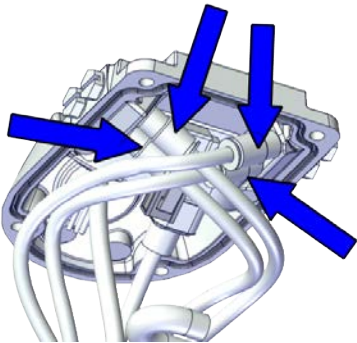
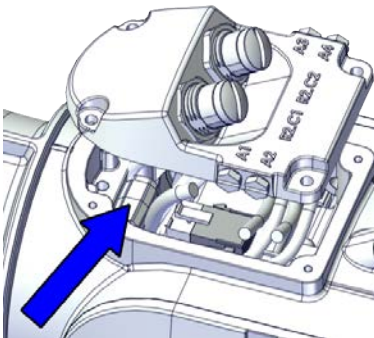
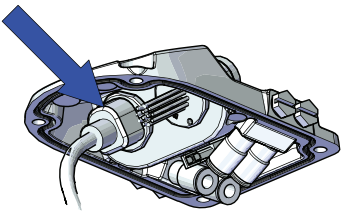
	Action	Note
4	Disconnect the air hoses.	 <p>xx1800002945</p>
5	For robots with CP/CS cabling Disconnect the connector. <ul style="list-style-type: none"> • J5.C1 	 <p>xx1800002947</p>
6	For robots with Ethernet cabling Disconnect the connector J5.C2 using the tool.	J5.C2 connector assembly tool: -  <p>xx1800002948</p>

Removing the wrist covers

	Action	Note
1	 DANGER Make sure that all supplies for electrical power, hydraulic pressure, and air pressure are turned off.	

Continues on next page



5 Repair

5.6.1 Replacing the housing

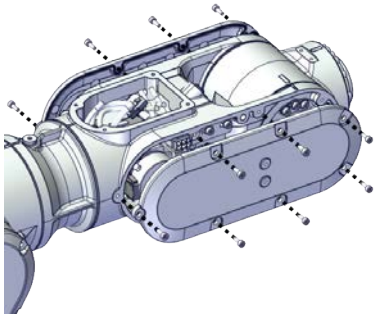
Continued

	Action	Note
2	 CAUTION For robots with protection type Clean Room Always cut the paint with a knife and grind the paint edge when disassembling parts of the robot! See Cut the paint or surface on the robot before replacing parts on page 124.	
3	Remove the wrist covers from both sides.	 xx1800002949

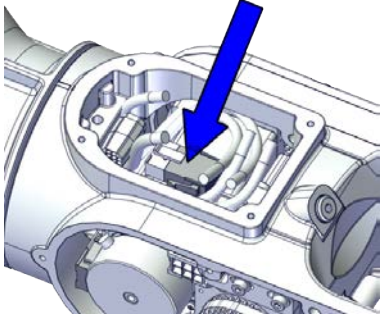

Disconnecting the axis-5 motor connectors

	Action	Note
1	 DANGER Make sure that all supplies for electrical power, hydraulic pressure, and air pressure are turned off.	
2	 CAUTION For robots with protection type Clean Room Always cut the paint with a knife and grind the paint edge when disassembling parts of the robot! See Cut the paint or surface on the robot before replacing parts on page 124.	
3	Access the connector FB5 from the process hub and disconnect the connector.	 xx1800002950

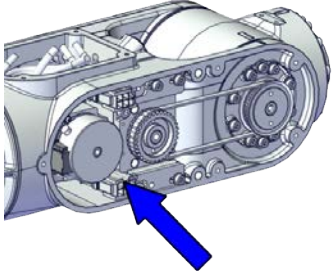
Continues on next page

	Action	Note
4	Disconnect the connector. <ul style="list-style-type: none"> • MP5 	 <p>xx1800002993</p>

Disconnecting the axis-6 motor connectors

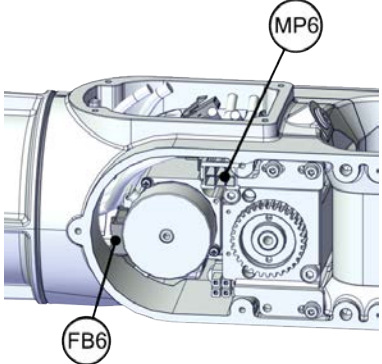
	Action	Note
1	 DANGER Make sure that all supplies for electrical power, hydraulic pressure, and air pressure are turned off.	
2	 CAUTION For robots with protection type Clean Room Always cut the paint with a knife and grind the paint edge when disassembling parts of the robot! See Cut the paint or surface on the robot before replacing parts on page 124.	
3	Disconnect the connectors. <ul style="list-style-type: none"> • MP6 • FB6 	 <p>xx1800002994</p>



Continues on next page

5 Repair

5.6.1 Replacing the housing

Continued

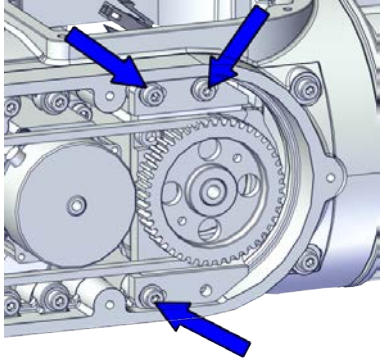
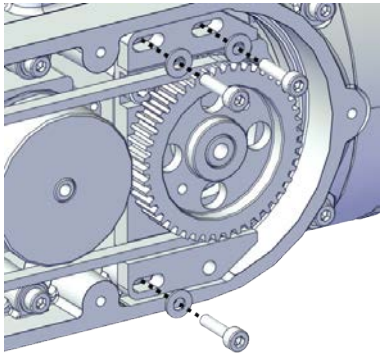

Removing the axis-6 motor

	Action	Note
1	 DANGER Make sure that all supplies for electrical power, hydraulic pressure, and air pressure are turned off.	
2	 CAUTION For robots with protection type Clean Room Always cut the paint with a knife and grind the paint edge when disassembling parts of the robot! See Cut the paint or surface on the robot before replacing parts on page 124 .	
3	 CAUTION Removing motors will release axes. This means the axes can fall down. Make sure axes are well supported before removing motors.	
4	Loosen the screws and move the motor slightly to slacken the timing belt.	 xx1800002995
5	Remove the screws and washers.	 xx1800002996
6	Carefully lift out the motor.	

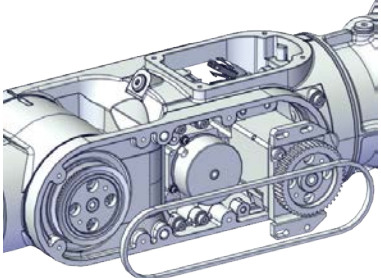
Continues on next page

	Action	Note
7	Remove the timing belt from its groove on the motor.	 <p>xx1800002997</p>

Loosening the cable package from axis-4 gearbox

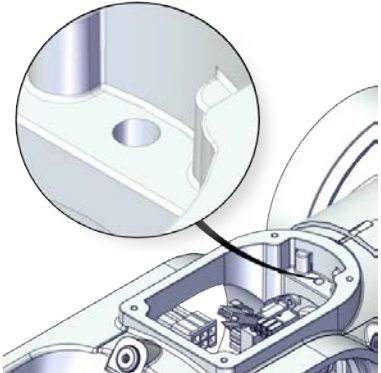
	Action	Note
1	 DANGER Make sure that all supplies for electrical power, hydraulic pressure, and air pressure are turned off.	
2	 CAUTION For robots with protection type Clean Room Always cut the paint with a knife and grind the paint edge when disassembling parts of the robot! See Cut the paint or surface on the robot before replacing parts on page 124 .	
3	Valid for IRB 1100-4/0.475 Access the cable package locking screw on the axis-4 gearbox from the wrist and then loosen the locking screw.	 <p>xx1800003031</p>

Continues on next page



5 Repair

5.6.1 Replacing the housing

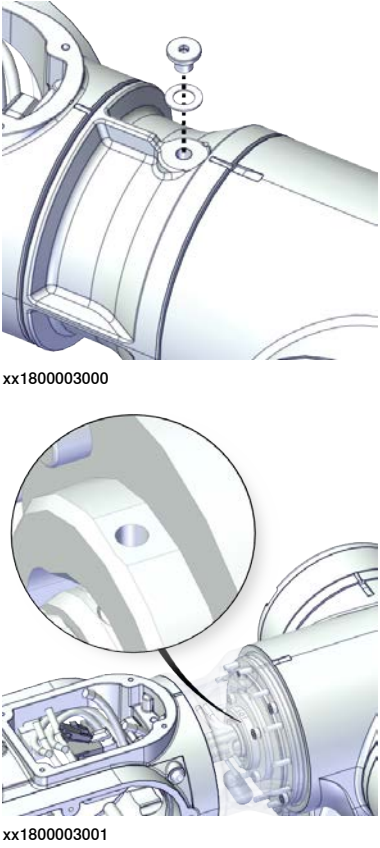
Continued

	Action	Note
4	Remove the plug screw and washer on the extender unit to access the cable package locking screw on the axis-4 gearbox and then loosen the locking screw.	 <p>xx1800003000</p> <p>xx1800003001</p>



Disconnecting the axis-4 motor connectors

	Action	Note
1	 DANGER Make sure that all supplies for electrical power, hydraulic pressure, and air pressure are turned off.	
2	 CAUTION For robots with protection type Clean Room Always cut the paint with a knife and grind the paint edge when disassembling parts of the robot! See Cut the paint or surface on the robot before replacing parts on page 124.	

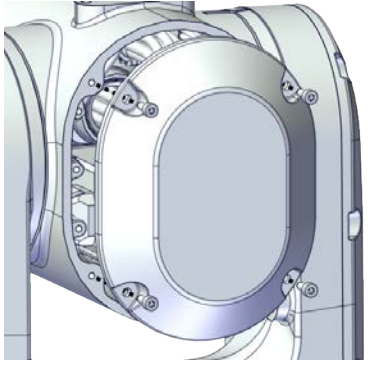
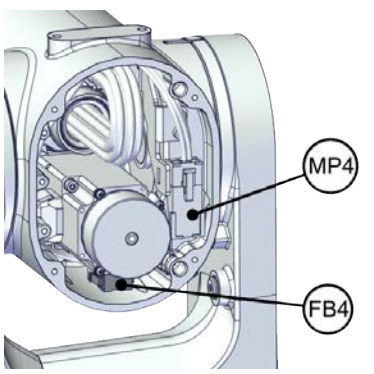
Continues on next page

	Action	Note
3	Remove the housing cover.	 <p>xx1800003011</p>
4	Disconnect the motor connectors. <ul style="list-style-type: none"> • FB4 • MP4 	 <p>xx1800003012</p>

Separating the upper cable package from the housing

	Action	Note
1	 <p>DANGER</p> <p>Make sure that all supplies for electrical power, hydraulic pressure, and air pressure are turned off.</p>	
2	 <p>CAUTION</p> <p>For robots with protection type Clean Room Always cut the paint with a knife and grind the paint edge when disassembling parts of the robot! See Cut the paint or surface on the robot before replacing parts on page 124.</p>	

Continues on next page



5 Repair

5.6.1 Replacing the housing

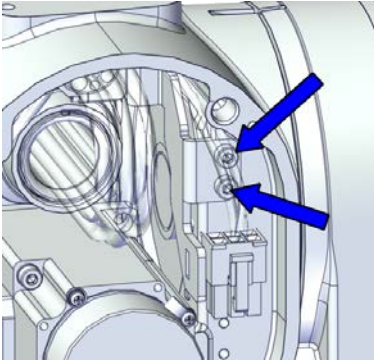
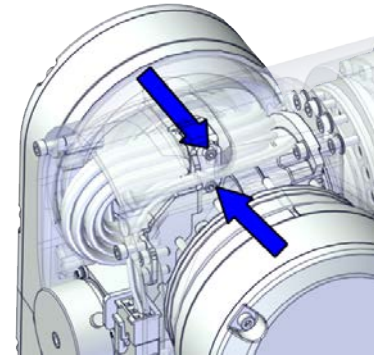
Continued

	Action	Note
3	Remove the cable bracket.	 <p>xx1800003013</p>  <p>xx1800003014</p>



Pulling out the upper cable harness

	Action	Note
1	 <p>DANGER</p> <p>Make sure that all supplies for electrical power, hydraulic pressure, and air pressure are turned off.</p>	
2	 <p>CAUTION</p> <p>For robots with protection type Clean Room Always cut the paint with a knife and grind the paint edge when disassembling parts of the robot! See Cut the paint or surface on the robot before replacing parts on page 124.</p>	

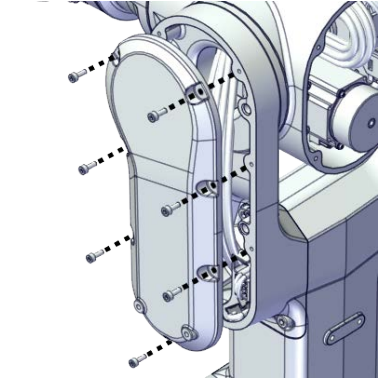
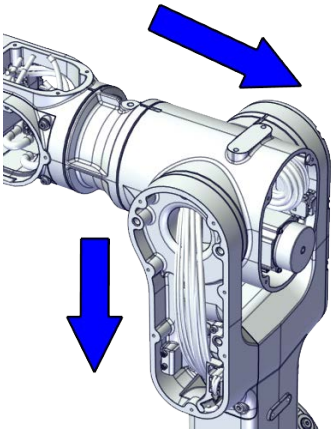
Continues on next page

	Action	Note
3	Remove the lower arm support cover.	 <p>xx1800003092</p>
4	Pull out the upper cable harness from the housing, out from the lower arm support.	 <p>xx1800003093</p>

Removing the axis-4 motor



	Action	Note
1	 DANGER Make sure that all supplies for electrical power, hydraulic pressure, and air pressure are turned off.	
2	 CAUTION For robots with protection type Clean Room Always cut the paint with a knife and grind the paint edge when disassembling parts of the robot! See Cut the paint or surface on the robot before replacing parts on page 124.	
3	 CAUTION Removing motors will release axes. This means the axes can fall down. Make sure axes are well supported before removing motors.	

Continues on next page

5 Repair

5.6.1 Replacing the housing

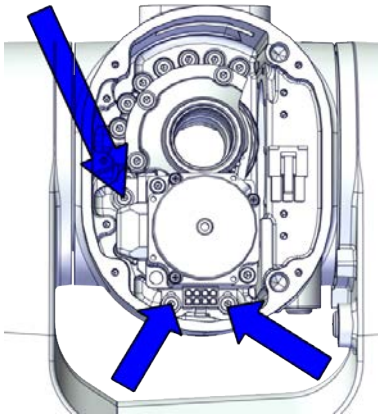
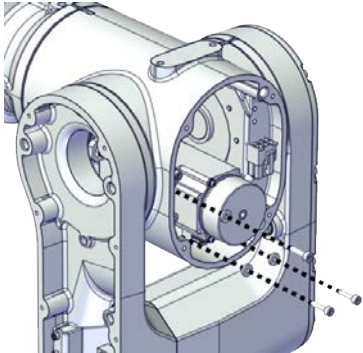

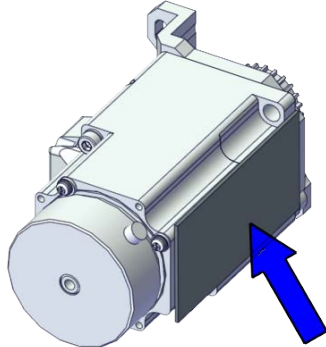
Continued

	Action	Note
4	Loosen the screws and move the motor slightly to slacken the timing belt.	 xx1800003094
5	Remove the screws and washers.	 xx1800003095
6	<p>Carefully lift out the motor.</p> <p> CAUTION</p> <p>A cooling pad is attached to the motor, which may stick to the casting. Always use a plastic sheet with caution to remove the pad from the casting. Pay attention not to scratch the casting or damage the pad.</p>	<p>Cooling pad location</p>  xx1800003605

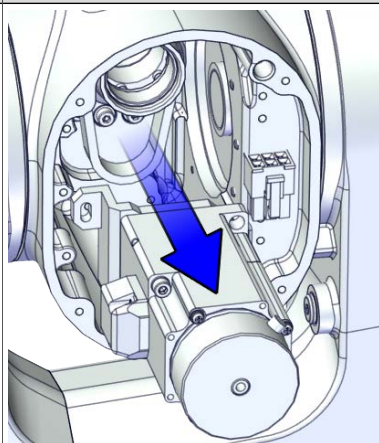
Continues on next page

	Action	Note
7	Remove the timing belt from its groove on the motor.	 <p>xx1800003096</p>

Removing the pulley cover and axis-4 timing belt

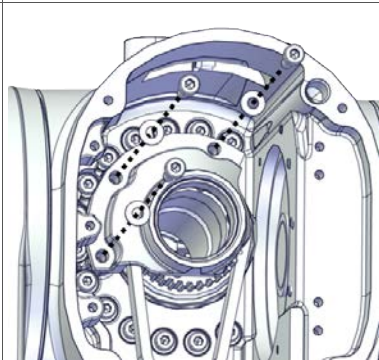
	Action	Note
1	 <p>DANGER</p> <p>Make sure that all supplies for electrical power, hydraulic pressure, and air pressure are turned off.</p>	
2	 <p>CAUTION</p> <p>For robots with protection type Clean Room Always cut the paint with a knife and grind the paint edge when disassembling parts of the robot! See Cut the paint or surface on the robot before replacing parts on page 124.</p>	
3	 <p>CAUTION</p> <p>Loosening timing belts will release axes. This means the axes can fall down. Make sure axes are well supported before loosening timing belts.</p>	
4	Remove the pulley cover.	 <p>xx1800003097</p>

Continues on next page



5 Repair

5.6.1 Replacing the housing

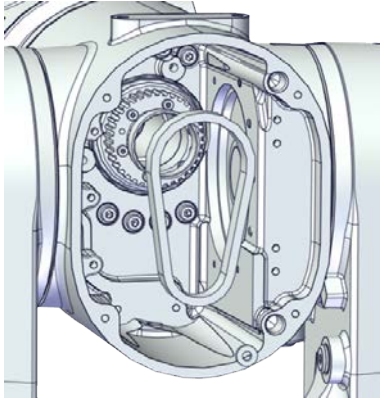
Continued

	Action	Note
5	Remove the timing belt from its groove on the gearbox.	 <p>xx1800003098</p>

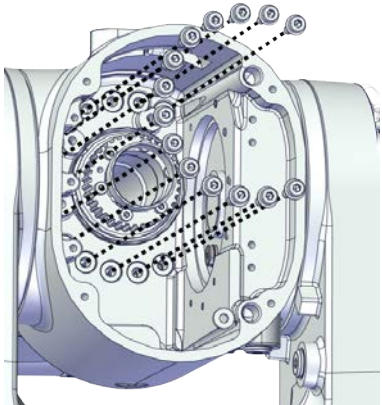

Separating the housing

	Action	Note
1	 DANGER Make sure that all supplies for electrical power, hydraulic pressure, and air pressure are turned off.	
2	 CAUTION For robots with protection type Clean Room Always cut the paint with a knife and grind the paint edge when disassembling parts of the robot! See Cut the paint or surface on the robot before replacing parts on page 124 .	
3	Remove the screws.  Note Some robots may be fitted with separate screws and washers. During replacement, always use the same screws (and washers) that are fitted on the robot at delivery. Contact ABB for more information.	 <p>xx1900002191</p>

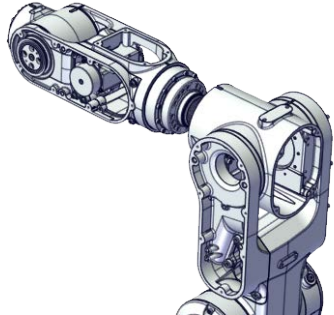
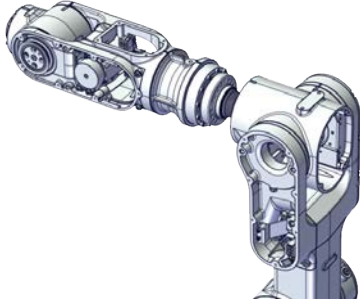
Continues on next page

	Action	Note
4	Valid for IRB 1100-4/0.475 Separate the wrist from the housing.	 xx1800003075
5	Separate the extender unit and wrist from the housing.	 xx1800003100

Disconnecting the axis-3 motor connectors





	Action	Note
1	 DANGER Make sure that all supplies for electrical power, hydraulic pressure, and air pressure are turned off.	
2	 CAUTION For robots with protection type Clean Room Always cut the paint with a knife and grind the paint edge when disassembling parts of the robot! See Cut the paint or surface on the robot before replacing parts on page 124.	

Continues on next page

5 Repair

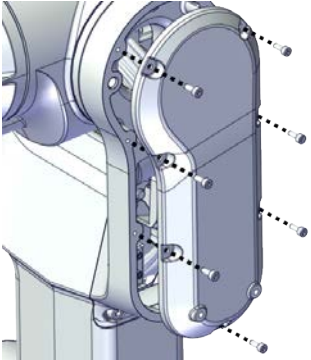

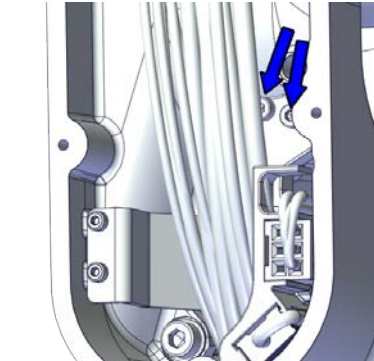
5.6.1 Replacing the housing

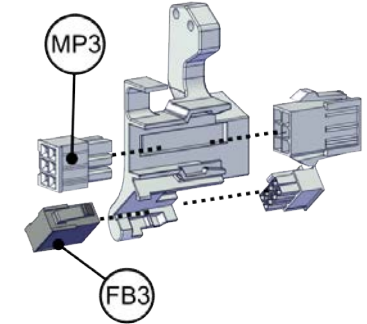
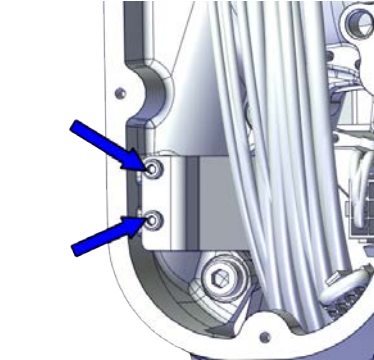
Continued



	Action	Note
3	Remove the lower arm support cover.	 xx1800003003
4	Remove the connector plate.  CAUTION Be aware of the cabling that are attached to the connector plate! The connector plate cannot be removed completely until the connectors are removed from the plate, as shown in following step.	 xx1800003004
5	Slide the connectors out of the connector plate and disconnect the connectors. <ul style="list-style-type: none">• FB3• MP3  Tip Take photos of the connector and cable position before disconnecting them, to have as a reference when reconnecting.	 xx1800003005
6	Remove the cable bracket.	 xx1800003006

Continues on next page

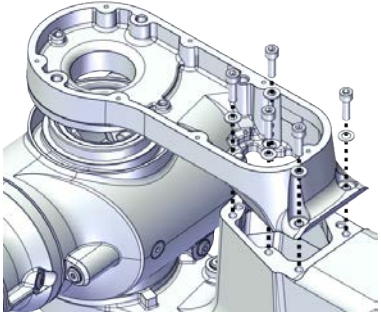
Removing the lower arm support

	Action	Note
1	 DANGER Make sure that all supplies for electrical power, hydraulic pressure, and air pressure are turned off.	
2	 CAUTION For robots with protection type Clean Room Always cut the paint with a knife and grind the paint edge when disassembling parts of the robot! See Cut the paint or surface on the robot before replacing parts on page 124 .	
3	Remove the lower arm support.  Tip If the lower arm support is hard to loosen from the housing, use a plastic hammer to knock on the lower arm support lightly.	 xx1800003088

Loosening the axis-3 motor

	Action	Note
1	 DANGER Make sure that all supplies for electrical power, hydraulic pressure, and air pressure are turned off.	
2	 CAUTION For robots with protection type Clean Room Always cut the paint with a knife and grind the paint edge when disassembling parts of the robot! See Cut the paint or surface on the robot before replacing parts on page 124 .	
3	 CAUTION Loosening timing belts will release axes. This means the axes can fall down. Make sure axes are well supported before loosening timing belts.	

Continues on next page

5 Repair

5.6.1 Replacing the housing



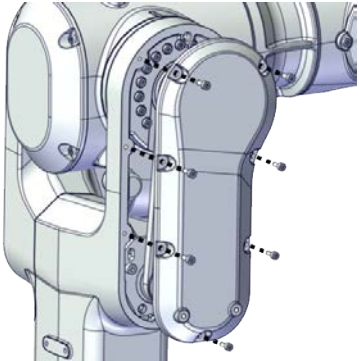
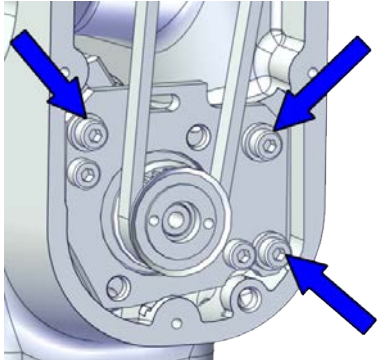
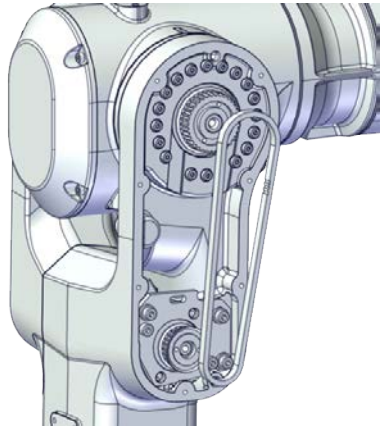

Continued

	Action	Note
4	Remove the lower arm cover.	 xx1800003007
5	Loosen the screws and move the motor slightly to slacken the timing belt.	 xx1800003008
6	Remove the timing belt from its grooves on the motor and gearbox.	 xx1800003022

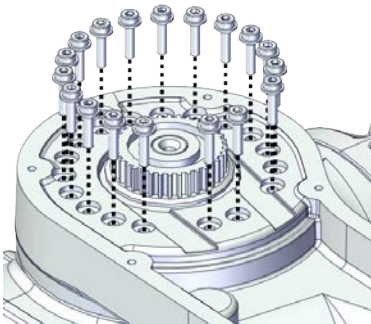

Separating the lower arm from the housing

	Action	Note
1	 DANGER Make sure that all supplies for electrical power, hydraulic pressure, and air pressure are turned off.	

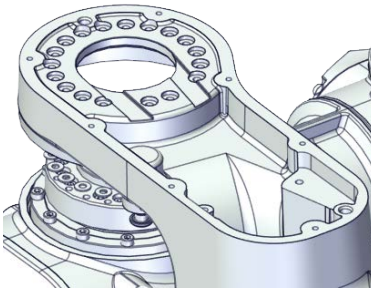
Continues on next page

	Action	Note
2	 CAUTION For robots with protection type Clean Room Always cut the paint with a knife and grind the paint edge when disassembling parts of the robot! See <i>Cut the paint or surface on the robot before replacing parts on page 124.</i>	
3	Remove the screws.  Note Some robots may be fitted with separate screws and washers. During replacement, always use the same screws (and washers) that are fitted on the robot at delivery. Contact ABB for more information.	 <small>xx1900002190</small>
4	Separate the lower arm from the housing.  Tip If the lower arm is hard to loosen from the housing, use a plastic hammer to knock on the lower arm lightly.	 <small>xx1800003090</small>

Removing the axis-3 gearbox

	Action	Note
1	 DANGER Make sure that all supplies for electrical power, hydraulic pressure, and air pressure are turned off.	
2	 CAUTION For robots with protection type Clean Room Always cut the paint with a knife and grind the paint edge when disassembling parts of the robot! See <i>Cut the paint or surface on the robot before replacing parts on page 124.</i>	

Continues on next page

5 Repair

5.6.1 Replacing the housing

Continued

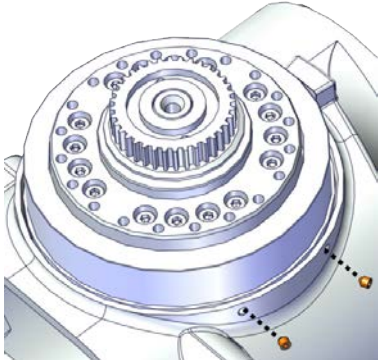
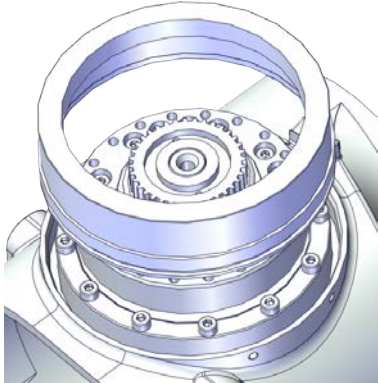
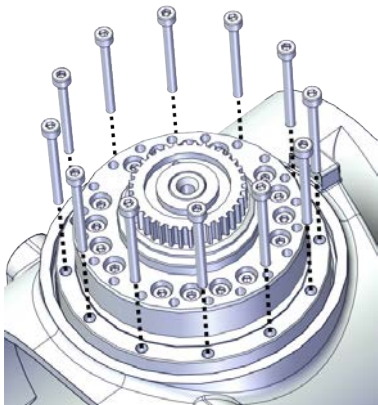
	Action	Note
3	<p> CAUTION</p> <p>Removing gearboxes will release axes. This means the axes can fall down.</p> <p>Make sure axes are well supported before removing gearboxes.</p>	
4	Remove the screws on the labyrinth sealing ring.	 <p>xx1900001425</p>
5	Remove the labyrinth sealing ring lightly and evenly.	 <p>xx1900001417</p>
6	Remove the screws.	 <p>xx1800003284</p>

Continues on next page

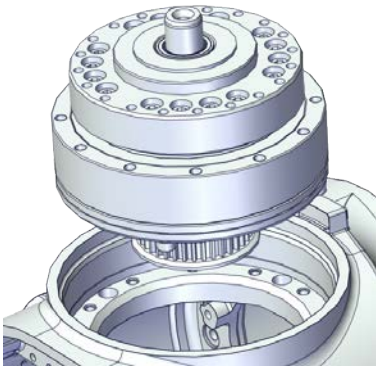
	Action	Note
7	Pull out the gearbox.	 <p>xx1800003285</p>

Refitting the housing

Use these procedures to refit the housing.

Refitting the axis-3 gearbox

	Action	Note
1	For robots with protection type Clean Room: Clean the joints that have been opened and wipe the parts free from particles with spirit on a lint free.	

Continues on next page

5 Repair

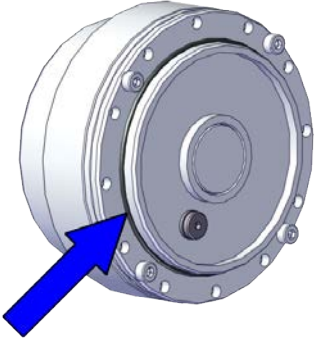
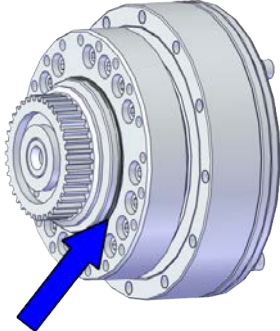
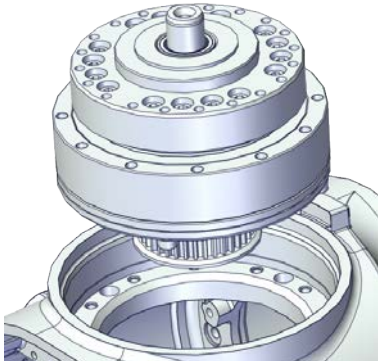

5.6.1 Replacing the housing

Continued

	Action	Note
2	<p>For robots with protection class IP67 (option 3350-670) For robots with protection type Clean Room (option 3351-4) Check the O-rings. Replace if damaged.</p>	<p>O-ring on flexible spline side: 3HAC061327-008</p>  <p>xx1900002197</p> <p>O-ring on circular spline side: 3HAC061327-009</p>  <p>xx1900002196</p>
3	Refit the axis-3 gearbox.	 <p>xx1800003285</p>

Continues on next page

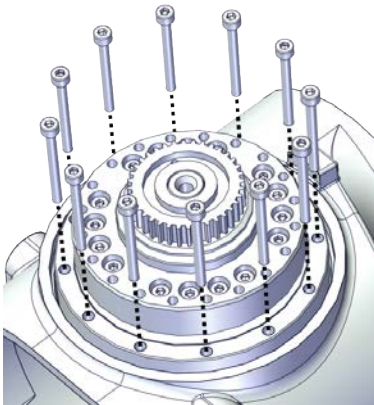
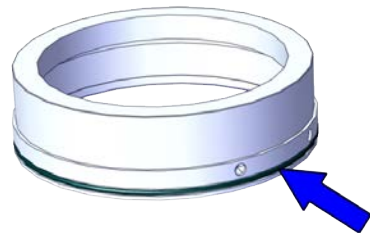
5.6.1 Replacing the housing Continued

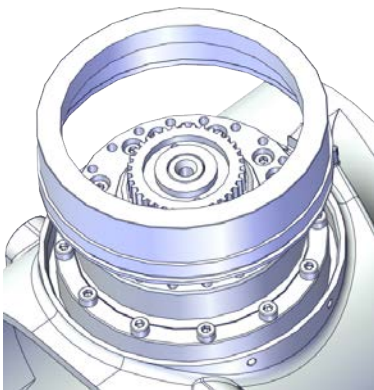
	Action	Note
4	Secure with screws.	<p>Screw: M3x30 12.9 Lafre 2C2B/FC6.9 (12 pcs) Tightening torque: 1.8 Nm</p>  <p>xx1800003284</p>
5	Check the O-ring. Replace if damaged.	 <p>xx1900001424</p>
6	<p>Refit the labyrinth sealing ring lightly and evenly.</p> <p> Note Make sure the labyrinth sealing ring is well fitted to the axis-3 gearbox without any deflection.</p>	 <p>xx1900001417</p>

Continues on next page

5 Repair

5.6.1 Replacing the housing

Continued

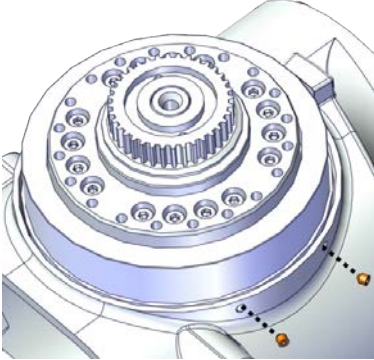
	Action	Note
7	Apply a little Loctite 243 to the screws and secure the labyrinth sealing ring with the screws.	Screw: M3x4 (2 pcs) Tightening torque: 0.8 Nm  <small>xx1900001425</small>

Refitting the lower arm to the housing

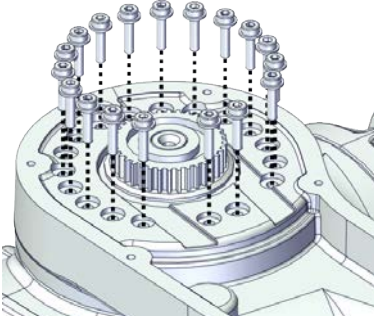

	Action	Note
1	For robots with protection type Clean Room: Clean the joints that have been opened and wipe the parts free from particles with spirit on a lint free.	
2	Refit the lower arm to the housing.  Note Some robots may be fitted with separate screws and washers. During replacement, always use the same screws (and washers) that are fitted on the robot at delivery. Contact ABB for more information.	Flange screws (16 pcs) For robots with protection class IP40 Tightening torque: 1.9 Nm For robots with protection class IP67 For robots with protection type Clean Room Tightening torque: 1.8 Nm  <small>xx1900002190</small>

Checking the radial sealing on the lower arm support (IP67 or Clean Room)

	Action	Note
1	For robots with protection type Clean Room: Clean the joints that have been opened and wipe the parts free from particles with spirit on a lint free.	

Continues on next page

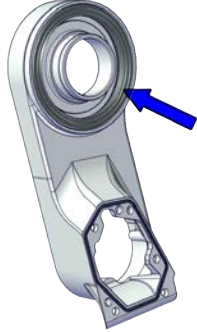
5.6.1 Replacing the housing
Continued

	Action	Note
2	Check the radial sealing on the lower arm support. Replace if damaged, as described below.	 <p>xx1900002202</p>
3	Apply a little grease to the new sealing when replacing the radial sealing and wipe clean after the replacement.	Grease: 3HAC029132-001
4	Place the new sealing in its groove in the lower arm support.	 <p>xx1900002160</p>
5	Place the dish-shaped plate of the radial sealing fitting tool against the radial sealing.	Axis-3 radial sealing assembly tool, included in the radial sealing assembly tool set 3HAC074609-001.
6	Fit the circular plate to the other side of the lower arm support with six M6x50 screws.	

Continues on next page

5 Repair

5.6.1 Replacing the housing

Continued

	Action	Note
7	Screw the screws, little by little, to press the sealing into place.	 xx1900002162
8	Remove the assembly tool.	
9	Check that the sealing is undamaged and properly fitted.	

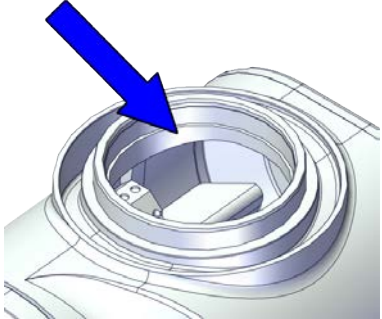
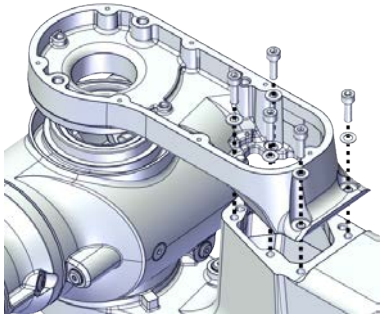

Securing the lower arm support

	Action	Note
1	For robots with protection type Clean Room: Clean the joints that have been opened and wipe the parts free from particles with spirit on a lint free.	
2	Apply grease Castrol Molub-Alloy 777-1 NG to the inner surface of the housing, where contacts the bearing on the lower arm support.	 xx2000000059
3	Refit the lower arm support.	<p>Screw: M5x16 12.9 Lafre 2C2B/FC6.9 (5 pcs) Tightening torque: 8 Nm</p>  xx1800003088

Continues on next page

	Action	Note
4	Route the cable package through the lower arm support.	

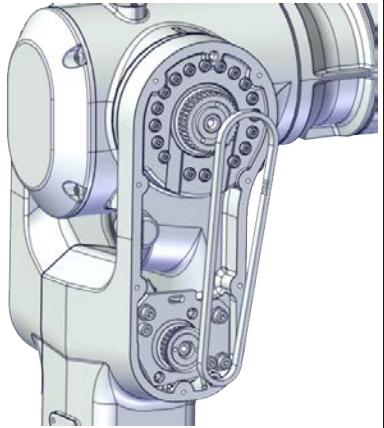
Securing the axis-3 motor

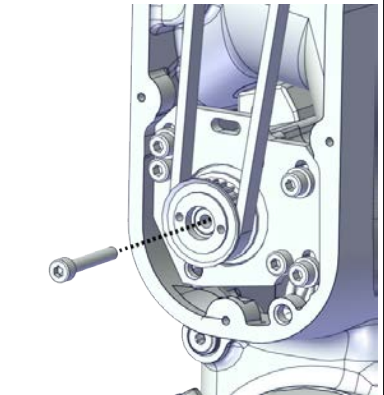
	Action	Note
1	For robots with protection type Clean Room: Clean the joints that have been opened and wipe the parts free from particles with spirit on a lint free.	
2	Install the timing belt to the pulleys and verify that the belt runs correctly in the grooves of the pulleys.	 <p>xx1800003022</p>
3	Install an M4x25 or longer adjustment screw to the motor.  Note Do not insert the entire screw to the hole.	 <p>xx1900000009</p>

Continues on next page

5 Repair

5.6.1 Replacing the housing

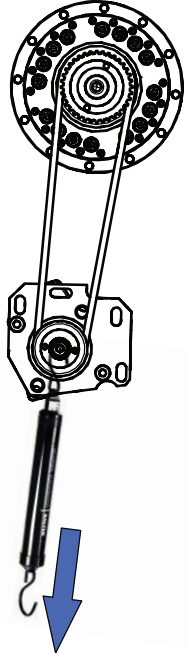
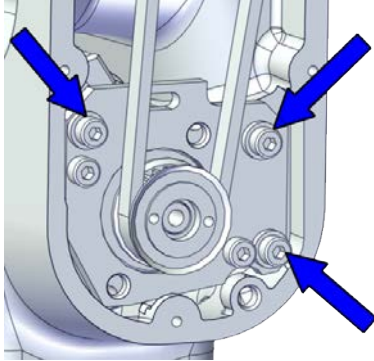

Continued

	Action	Note
4	Use a handheld dynamometer hooking to the screw and pull the dynamometer to reach the initial referenced force.	<p>Initial referenced force for used belt: 21.7-23.94 N (for reference only) Initial referenced force for new belt: 31-34.2 N</p>  <p>xx190000028</p>
5	Secure the motor with the screws.	<p>Screw: M4x12 12.9 Lafre 2C2B/FC6.9 (3 pcs) Washer, 3HAC063985-001 (3 pcs) Tightening torque: 3 Nm</p>  <p>xx1800003008</p>
6	Use a sonic tension meter to measure the timing belt tension.	<p>Used belt: 102-109 Hz New belt: 113-143 Hz (for reference only)</p>
7	If the timing belt tension does not meet the requirement, loosen the motor screws and readjust.	

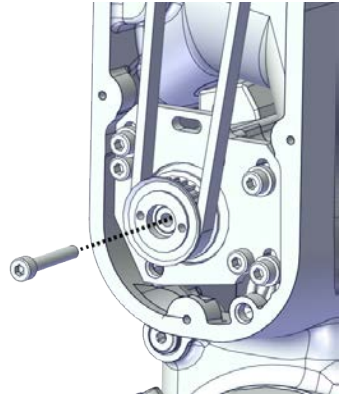
Continues on next page

	Action	Note
8	Remove the adjustment screw from the motor.	 <p>xx1900000009</p>

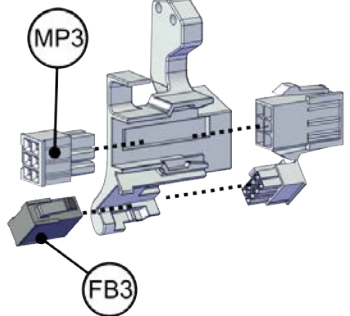
Reconnecting the axis-3 motor connectors

	Action	Note
1	For robots with protection type Clean Room: Clean the joints that have been opened and wipe the parts free from particles with spirit on a lint free.	
2	Slide the connectors into the connector plate and reconnect the connectors. <ul style="list-style-type: none"> • FB3 • MP3  Tip See the number markings on the connectors for help to find the corresponding connector.	 <p>xx1800003005</p>
3	Route and secure the cabling with cable straps.  CAUTION Correct cable routing is highly important. If the cables are routed and secured incorrectly the cables can be damaged.	

Continues on next page

5 Repair

5.6.1 Replacing the housing

Continued

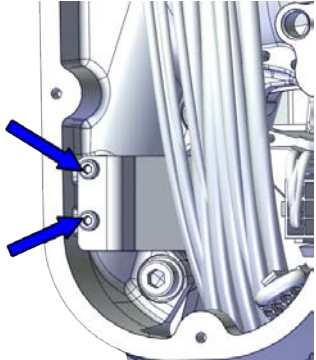
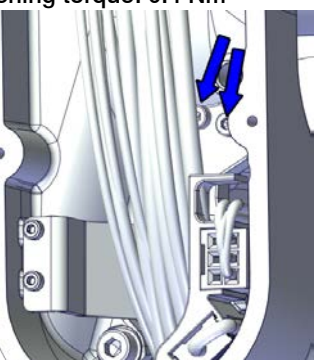

	Action	Note
4	Refit the cable bracket.	<p>Screw: M2.5x6 12.9 Lafre 2C2B/FC6.9 (2 pcs) Tightening torque: 0.6 Nm</p>  <p>xx1800003006</p>
5	Refit the connector plate.	<p>Screw: M3x12 12.9 Lafre 2C2B/FC6.9 (2 pcs) Tightening torque: 0.4 Nm</p>  <p>xx1800003004</p>

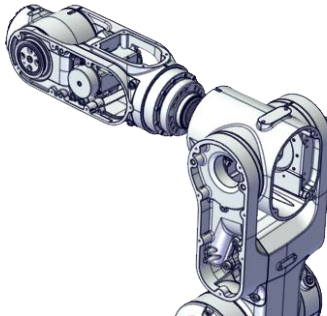
Refitting the housing

	Action	Note
1	For robots with protection type Clean Room: Clean the joints that have been opened and wipe the parts free from particles with spirit on a lint free.	
2	Valid for IRB 1100-4/0.475 Refit the the wrist to the housing.	 <p>xx1800003075</p>

Continues on next page

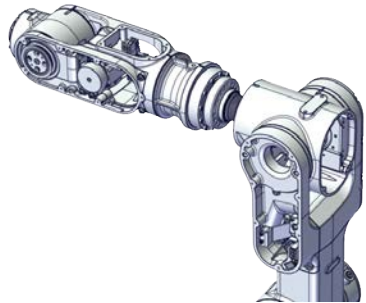
5.6.1 Replacing the housing
Continued

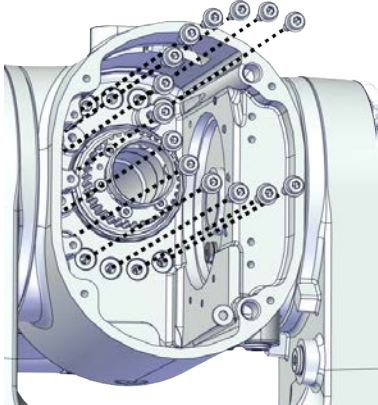
	Action	Note
3	Refit the extender unit and wrist to the housing.	 <p>xx1800003100</p>
4	<p>Refit the screws and washers.</p> <p> Note</p> <p>Some robots may be fitted with separate screws and washers. During replacement, always use the same screws (and washers) that are fitted on the robot at delivery. Contact ABB for more information.</p>	<p>Flange screws (14 pcs) For robots with protection class IP40 Tightening torque: 1.9 Nm For robots with protection class IP67 For robots with protection type Clean Room Tightening torque: 1.8 Nm</p>  <p>xx1900002191</p>

Refitting the axis-4 timing belt and pulley cover

	Action	Note
1	<p>For robots with protection type Clean Room: Clean the joints that have been opened and wipe the parts free from particles with spirit on a lint free.</p>	

Continues on next page

5 Repair

5.6.1 Replacing the housing

Continued

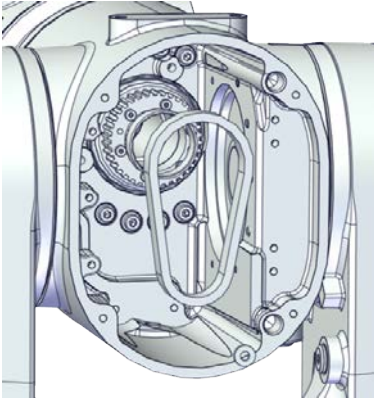
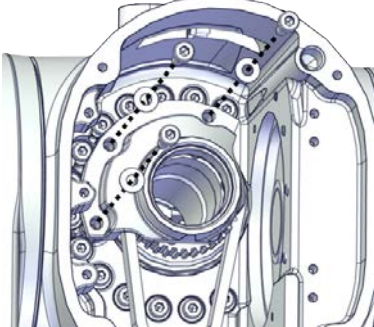

	Action	Note
2	Install the timing belt to the gearbox pulley and verify that the belt runs correctly in the groove of the pulley.	 <p>xx1800003098</p>
3	Refit the pulley cover.	<p>Screw: M3x8 12.9 Lafre 2C2B/FC6.9 (3 pcs) Tightening torque: 1.2 Nm</p>  <p>xx1800003097</p>

Refitting the axis-4 motor

	Action	Note
1	For robots with protection type Clean Room: Clean the joints that have been opened and wipe the parts free from particles with spirit on a lint free.	
2	Check that: <ul style="list-style-type: none"> • all assembly surfaces are clean and without damages • the motor is clean and undamaged. 	

Continues on next page

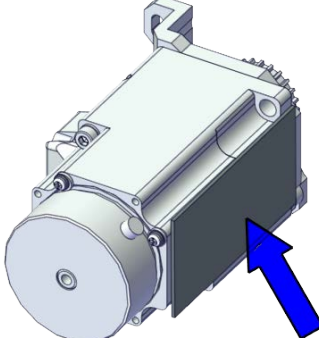
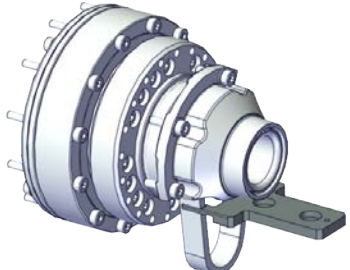
5.6.1 Replacing the housing
Continued

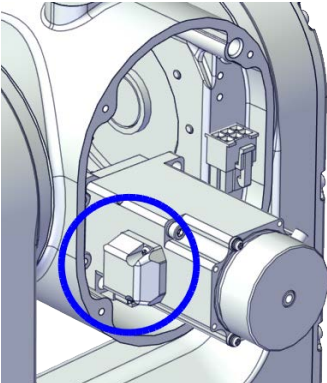

	Action	Note
3	<p>Check the cooling pad. Replace if damaged.</p>	<p>Cooling pad for axis-3 and -4 motors: 3HAC071021-001</p>  <p>xx1800003605</p>
4	<p>Use the motor fitting tool to fix the timing belt.</p>	<p>axis-4 motor fitting tool, included in the special toolkit 3HAC071022-001.</p>  <p>xx1900000044</p>
5	<p>Orient the motor correctly and fit it into the housing.</p> <p> Note</p> <p>Make sure the motor flange does not press on the timing belt.</p>	<p>Motor orientation: orient the motor according to the figure below, in regard to the encircled motor connector.</p>  <p>xx1800003287</p>

Continues on next page

5 Repair

5.6.1 Replacing the housing

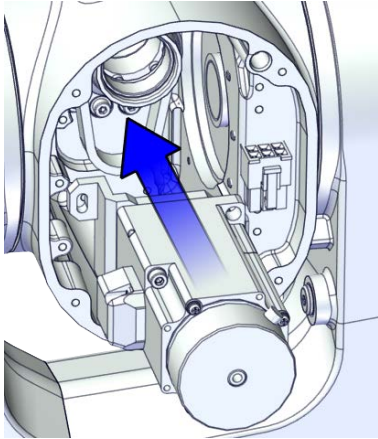

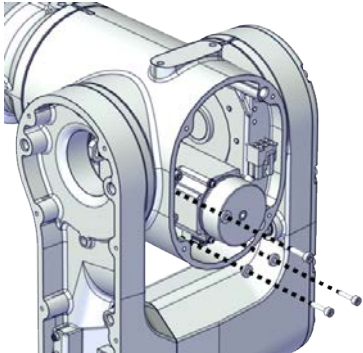
Continued

	Action	Note
6	Install the timing belt to the motor pulley.	 xx1800003617
7	Refit the screws and washers.  Note Do not tighten the screws yet.	Screw: M3x12 12.9 Lafre 2C2B/FC6.9 (3 pcs) Washer, 3HAC064765-001 (3 pcs)  xx1800003095
8	Remove the motor fitting tool.	

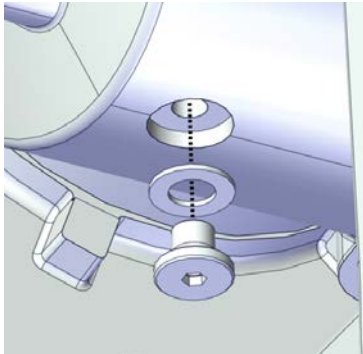
Adjusting the axis-4 timing belt tension

	Action	Note
1	For robots with protection type Clean Room: Clean the joints that have been opened and wipe the parts free from particles with spirit on a lint free.	
2	Remove the screw and washer below the housing.	 xx1900000036

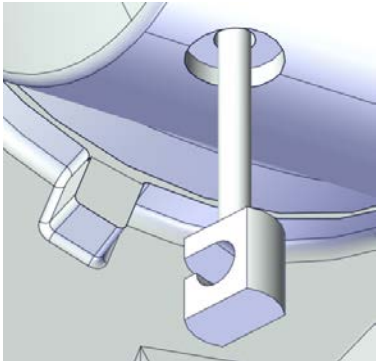
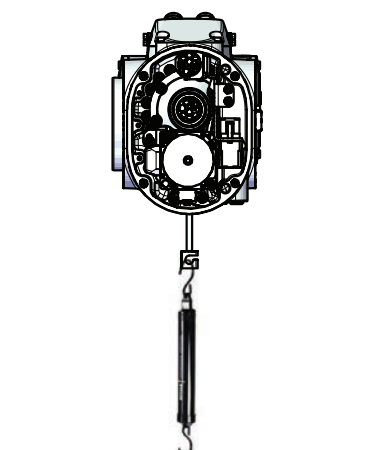
Continues on next page

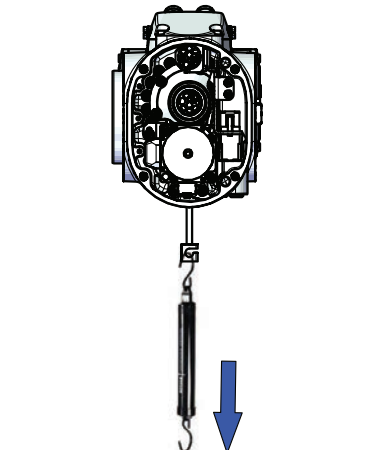
	Action	Note
3	Fit an M3x25 eye bolt o the screw hole.	 <p>xx1900000037</p>
4	Use a handheld dynamometer hooking to the eye bolt.	 <p>xx1900000038</p>
5	<p>Pull the dynamometer to make the tension falling in the allowed force range.</p> <p> Note Pay attention to the force application direction.</p>	<p>Used belt: 20.09-22.05 N New belt:28.7-31.5 N</p>  <p>xx1900000039</p>

Continues on next page

5 Repair

5.6.1 Replacing the housing

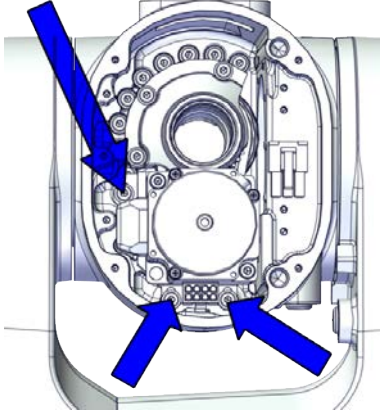

Continued

	Action	Note
6	Secure the motor with the screws.	<p>Tightening torque: 1.4 Nm</p>  <p>xx1800003094</p>
7	Remove eye bolt and refit the screw and washer below the housing.	<p>Plug screw: 3HAC064146-001 For robots with protection type Clean Room (option 3351-4) Plug screw, Clean Room: 3HAC070309-001 For robots with protection class IP67 (option 3350-670) For robots with protection type Clean Room (option 3351-4) Rubber sealing washer on housing: 3HAC064147-001 Tightening torque: 2 Nm</p>

Refitting the upper cable harness through the axis-4 gearbox

	Action	Note
1	For robots with protection type Clean Room: Clean the joints that have been opened and wipe the parts free from particles with spirit on a lint free.	

Continues on next page

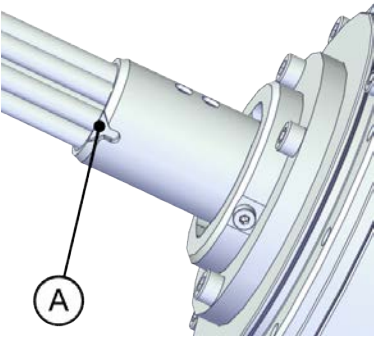
	Action	Note
2	<p>Insert the cable package from the lower arm support, into the housing and through the axis-4 gearbox.</p> <p> Tip Wrap the connectors with the masking tape.</p> <p> CAUTION Make sure that no cables or hoses are twisted or strained. Reroute if necessary.</p>	<p>Cable protection tube orientation: use the notch (A) on the cable protection tube as a reference when inserting the cable package, which should be at the opposite direction to the locking screw hole on the gearbox.</p>  <p>xx1800003017</p>

Securing the upper cable package to the axis-4 gearbox

	Action	Note
1	<p>For robots with protection type Clean Room: Clean the joints that have been opened and wipe the parts free from particles with spirit on a lint free.</p>	

Continues on next page



5 Repair

5.6.1 Replacing the housing

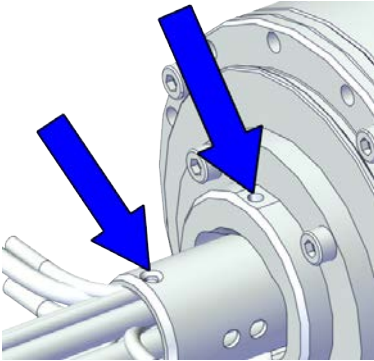
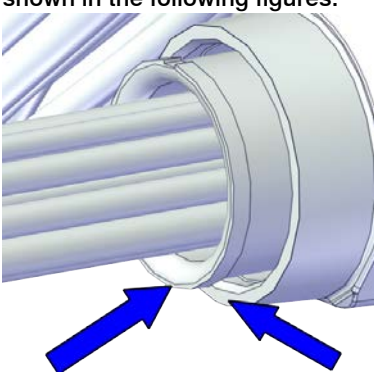
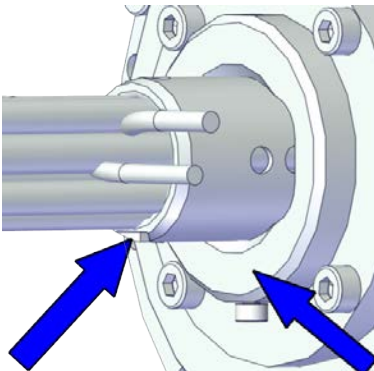
Continued

	Action	Note
2	<p>Make sure that:</p> <ul style="list-style-type: none">• The hole on the cable protection tube is aligned with the locking screw hole on the gearbox.• The cable protection tube surface is completely parallel with the pulley cover at one side and with the flange at the other side.	<p>Holes to be aligned are shown in the following figure.</p>  <p>xx1800003018</p> <p>Surfaces to be paralleled are shown in the following figures.</p>  <p>xx1800003019</p>  <p>xx1800003020</p>

Continues on next page

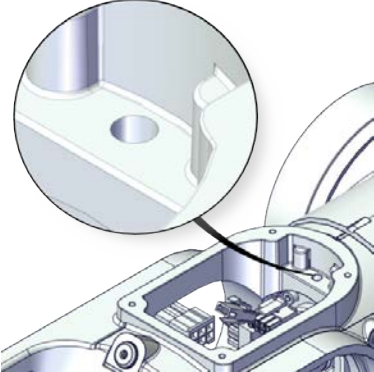
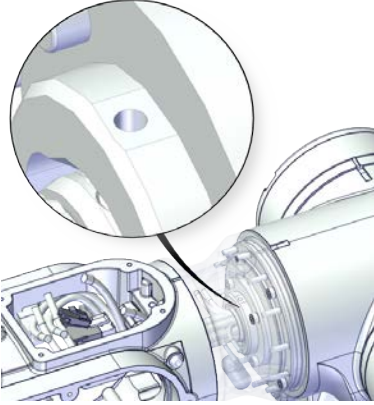
	Action	Note
3	<p>Apply a little Loctite 243 to the locking screw and refit the locking screw.</p> <p> Note</p> <p>Make sure the locking screw header is parallel with flange surface.</p> <p> Note</p> <p>If there is locking liquid residues on the screw or screw hole, please clean it before refitting. Remove residual locking liquid after refitting.</p>	<p>Screw: M3x8 (1 pcs) Tightening torque: 0.4 Nm Valid for IRB 1100-4/0.475</p>  <p>xx1800003031</p>  <p>xx1800003001</p>

Continues on next page

5 Repair

5.6.1 Replacing the housing

Continued

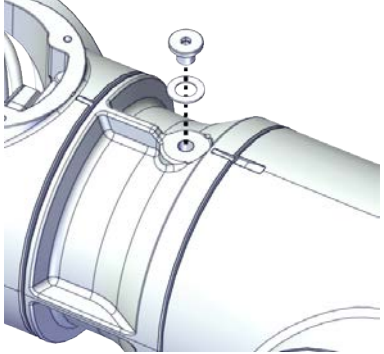

	Action	Note
4	Refit the plug screw and washer on the extender unit.	<p>Plug screw: 3HAC064146-001 For robots with protection type Clean Room (option 3351-4) Plug screw, Clean Room: 3HAC070309-001 For robots with protection class IP67 (option 3350-670) For robots with protection type Clean Room (option 3351-4) Rubber sealing washer on extender unit: 3HAC067995-001 Tightening torque: 2 Nm</p>  <p>xx1800003000</p>

Securing the upper cable package to the housing

	Action	Note
1	For robots with protection type Clean Room: Clean the joints that have been opened and wipe the parts free from particles with spirit on a lint free.	

Continues on next page

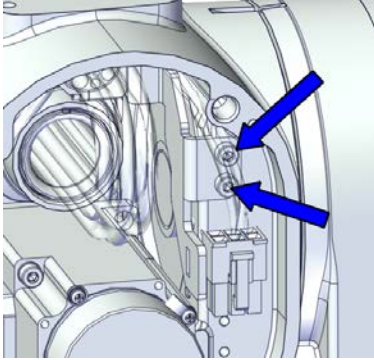
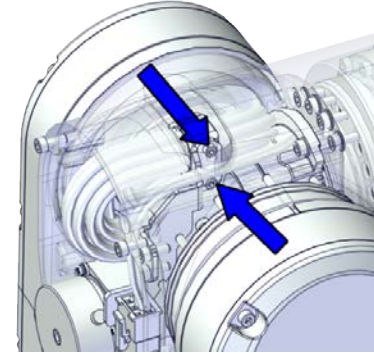
5.6.1 Replacing the housing
Continued

	Action	Note
2	Refit the cable bracket.	<p>Screw: M3x8 12.9 Lafre 2C2B/FC6.9 (2 pcs) Tightening torque: 0.8 Nm</p>  <p>xx1800003013</p> <p>Screw: M2.5x6 12.9 Lafre 2C2B/FC6.9 (2 pcs) Tightening torque: 0.6 Nm</p>  <p>xx1800003014</p>
3	<p>Route and secure the cabling with cable straps.</p> <p> CAUTION</p> <p>Correct cable routing is highly important. If the cables are routed and secured incorrectly the cables can be damaged.</p>	

Reconnecting the axis-4 motor connectors



	Action	Note
1	<p>For robots with protection type Clean Room: Clean the joints that have been opened and wipe the parts free from particles with spirit on a lint free.</p>	

Continues on next page

5 Repair

5.6.1 Replacing the housing

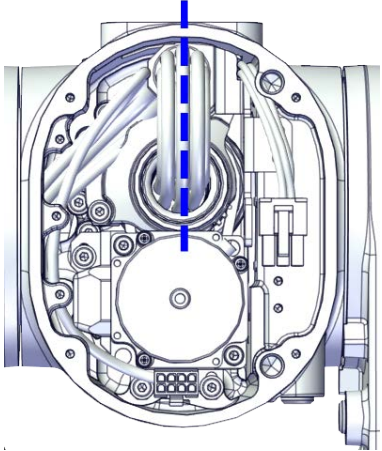
Continued

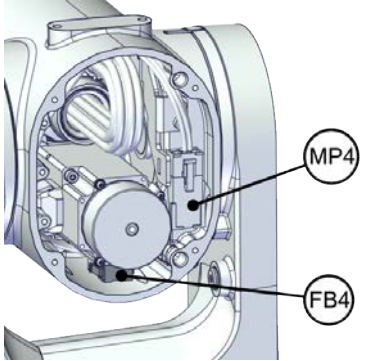

	Action	Note
2	<p>Check the cabling status. Make sure the cabling is in vertical state and is not twisted.</p>	 <p>xx1800003618</p>
3	<p>Reconnect the connectors.</p> <ul style="list-style-type: none"> • FB4 • MP4 <p> Tip</p> <p>See the number markings on the connectors for help to find the corresponding connector.</p>	 <p>xx1800003012</p>

Refitting the axis-6 motor

	Action	Note
1	<p>For robots with protection type Clean Room: Clean the joints that have been opened and wipe the parts free from particles with spirit on a lint free.</p>	
2	<p>Check that:</p> <ul style="list-style-type: none"> • all assembly surfaces are clean and without damages • the motor is clean and undamaged. 	

Continues on next page

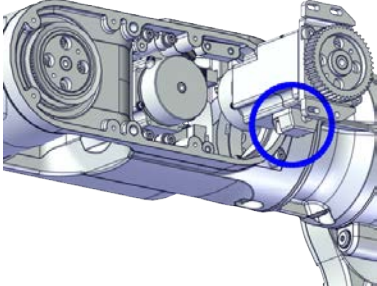
5.6.1 Replacing the housing Continued

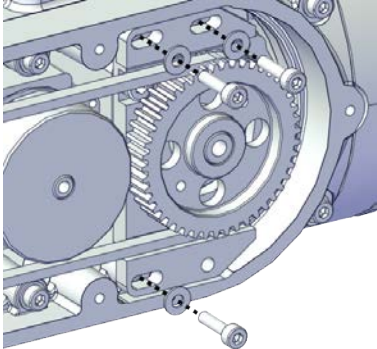
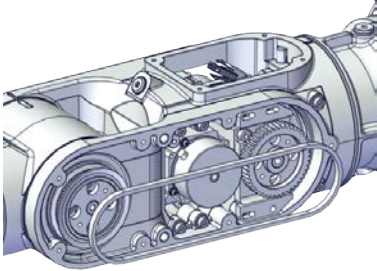
	Action	Note
3	<p>Orient the motor correctly and fit it into the lower arm.</p> <p> Tip</p> <p>Leave the connectors FB5 and FB6 accessible from the process hub and the connectors MP5 and MP6 accessible from wrist side.</p>	<p>Motor orientation: orient the motor according to the figure below, in regard to the encircled motor connector.</p>  <p>xx1800003023</p>
4	<p>Refit the screws and washers.</p> <p> Note</p> <p>Do not tighten the screws yet.</p>	<p>Screw: M3x12 12.9 Lafre 2C2B/FC6.9 (3 pcs)</p>  <p>xx1800002996</p>
5	<p>Install the timing belt to the pulleys and verify that the belt runs correctly in the grooves of the pulleys.</p>	 <p>xx1800003024</p>

Continues on next page

5 Repair

5.6.1 Replacing the housing

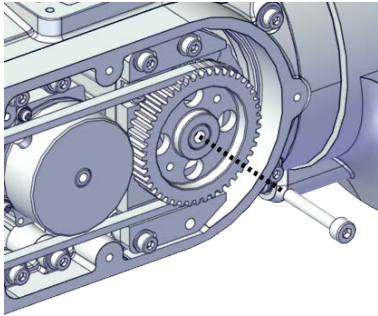
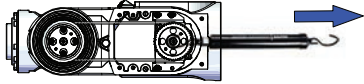
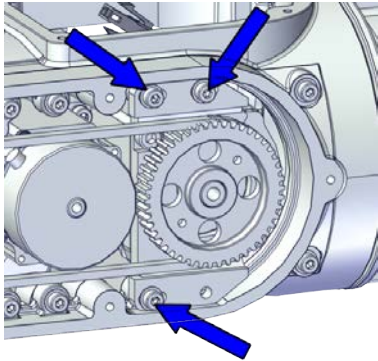

Continued

	Action	Note
6	Install an M4x25 or longer adjustment screw to the motor.  Note Do not insert the entire screw to the hole.	 xx190000007
7	Use a handheld dynamometer hooking to the screw and pull the dynamometer to reach the initial referenced force.	Initial referenced force for used belt: 8.96-9.8 N (for reference only) Initial referenced force for new belt: 12.8-14  xx190000026
8	Secure the motor with the screws.	Tightening torque: 1.4 Nm  xx1800002995
9	Use a sonic tension meter to measure the timing belt tension.	Used belt: 81.3-86.9 Hz New belt: 90-114 Hz (for reference only)
10	If the timing belt tension does not meet the requirement, loosen the motor screws and readjust.	

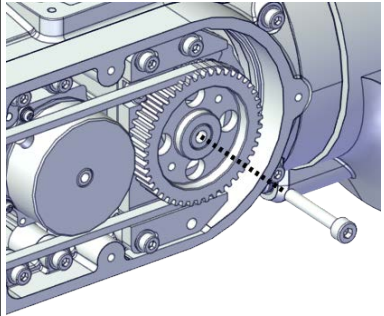
Continues on next page

	Action	Note
11	Remove the adjustment screw from the motor.	 <p>xx190000007</p>

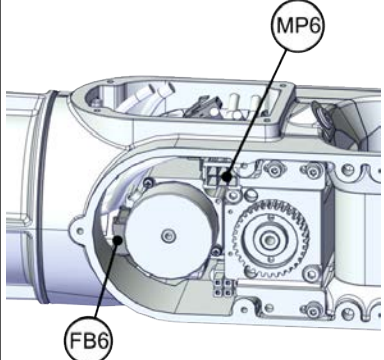
Reconnecting the axis-6 motor connectors

	Action	Note
1	For robots with protection type Clean Room: Clean the joints that have been opened and wipe the parts free from particles with spirit on a lint free.	
2	Reconnect the connectors. <ul style="list-style-type: none"> • FB6 • MP6  Tip See the number markings on the connectors for help to find the corresponding connector.	 <p>xx1800002994</p>
3	Route and secure the cabling with cable straps.  CAUTION Correct cable routing is highly important. If the cables are routed and secured incorrectly the cables can be damaged.	
4	Insert the cabling and connectors into the wrist.	

Reconnecting the axis-5 motor connectors



	Action	Note
1	For robots with protection type Clean Room: Clean the joints that have been opened and wipe the parts free from particles with spirit on a lint free.	

Continues on next page

5 Repair

5.6.1 Replacing the housing

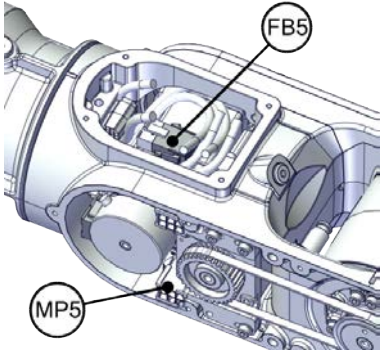

Continued

	Action	Note
2	<p>Reconnect the connectors.</p> <ul style="list-style-type: none"> • FB5 • MP5 <p> Tip</p> <p>See the number markings on the connectors for help to find the corresponding connector.</p>	 <p>xx1800003025</p>
3	<p>Route and secure the cabling with cable straps.</p> <p> CAUTION</p> <p>Correct cable routing is highly important. If the cables are routed and secured incorrectly the cables can be damaged.</p>	
4	<p>Insert the cabling and connectors into the wrist.</p>	

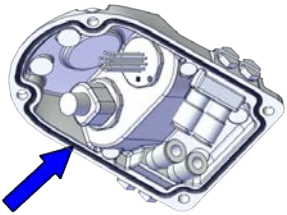
Refitting the process hub

	Action	Note
1	<p>For robots with protection type Clean Room: Clean the joints that have been opened and wipe the parts free from particles with spirit on a lint free.</p>	
2	<p>For robots with protection class IP67 (option 3350-670) For robots with protection type Clean Room (option 3351-4) Check the gasket. Replace if damaged.</p>	<p>Gasket for process hub: 3HAC065352-001</p>  <p>xx1900002187</p>

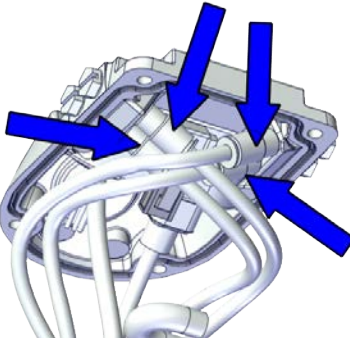
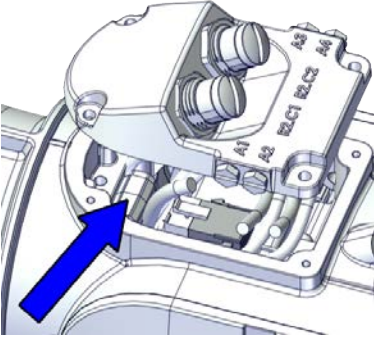
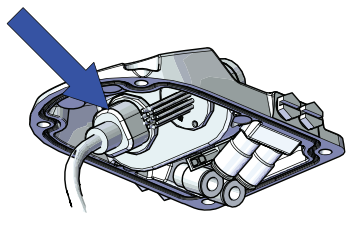
Continues on next page

	Action	Note
3	<p>Reconnect the air hoses in a cross pattern.</p> <p> Tip</p> <p>See the number markings on the air hoses for help to find the corresponding air hoses.</p> <p>The air hoses with the same number connect to the same Y-shaped connector.</p>	 <p>xx1800002945</p>
4	<p>For robots with CP/CS cabling</p> <p>Reconnect the connector.</p> <ul style="list-style-type: none"> • J5.C1 	 <p>xx1800002947</p>
5	<p>For robots with Ethernet cabling</p> <p>Reconnect the connector J5.C2 using the tool.</p>	<p>J5.C2 connector assembly tool, included in the special toolkit 3HAC071022-001</p>  <p>xx1800002948</p>
6	<p>Route and secure the cabling with cable straps.</p> <p> CAUTION</p> <p>Correct cable routing is highly important.</p> <p>If the cables are routed and secured incorrectly the cables can be damaged.</p>	

Continues on next page

5 Repair

5.6.1 Replacing the housing

Continued

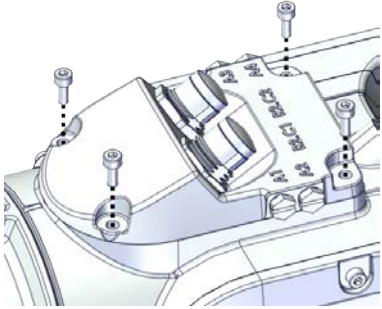
	Action	Note
7	Refit the cover.	<p>Screw: M3x8 12.9 Lafre 2C2B/FC6.9 (4 pcs) Tightening torque: 1.2 Nm</p>  <p>xx1800002944</p>

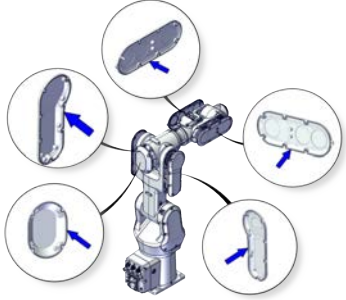

Refitting the covers

	Action	Note
1	For robots with protection type Clean Room: Clean the joints that have been opened and wipe the parts free from particles with spirit on a lint free.	
2	<p>For robots with protection class IP67 (option 3350-670) For robots with protection type Clean Room (option 3351-4) Check the gaskets. Replace if damaged.</p>	 <p>xx1900002177</p>
3	Apply grease to the cable package, cover all moving area of the package.	
4	Apply grease to the covers that have contacting area with the cable package.	

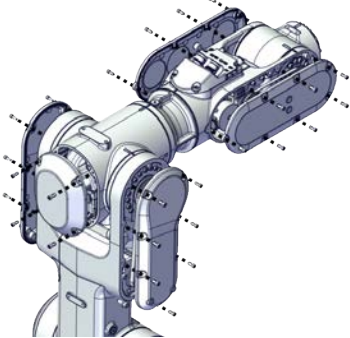
Continues on next page

	Action	Note
5	<p>Refit the covers.</p> <ul style="list-style-type: none"> • Wrist covers • Lower arm cover • Lower arm support cover • Housing cover 	<p>Screw: M3x8 12.9 Lafre 2C2B/FC6.9 Tightening torque: 1.2 Nm</p>  <p>xx1800003611</p>

Concluding procedure

	Action	Note
1	<p>For robots with protection type Clean Room: Clean and paint the joints that have been opened. See Cut the paint or surface on the robot before replacing parts on page 124</p> <p> Note</p> <p>After all repair work, wipe the Clean Room robot free from particles with spirit on a lint free cloth.</p>	
2	Recalibrate the robot.	Calibration is detailed in section Calibration on page 685 .
3	<p> DANGER</p> <p>Make sure all safety requirements are met when performing the first test run. See Test run after installation, maintenance, or repair on page 91.</p>	

5 Repair

5.6.2 Replacing the extender unit and wrist

5.6.2 Replacing the extender unit and wrist

Location of the extender unit and wrist

The IRB 1100-4/0.58 has an extender unit connecting the housing and wrist, which is located as shown in the figure.

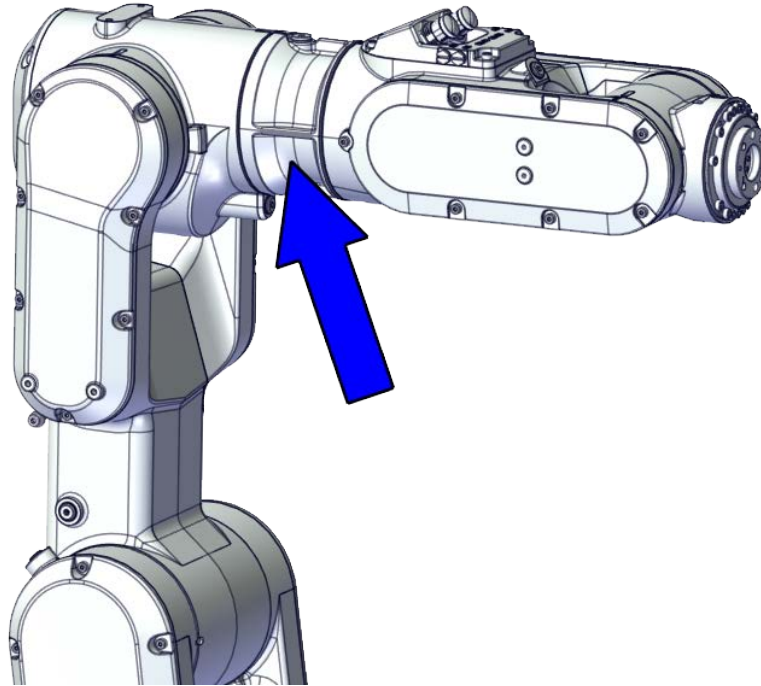

xx1800002476

Continues on next page

The wrist is located as shown in the figure.

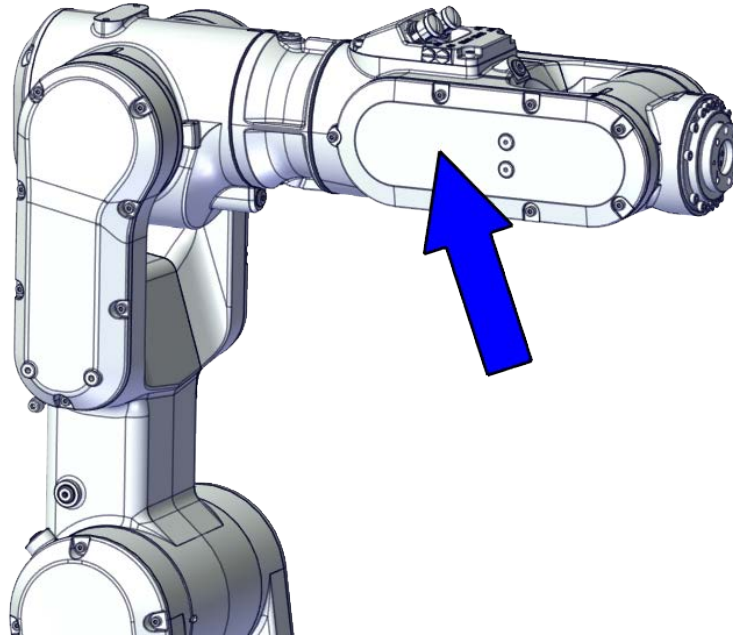

xx1800002477

Required spare parts



Note

The spare part numbers that are listed in the table can be out of date. See the latest spare parts of the IRB 1100 via myABB Business Portal, www.abb.com/myABB.

Spare part	Article number	Note
Process hub, basic	3HAC069094-001	
Process hub, basic, Clean Room	3HAC075509-001	Used with protection type Clean Room.
Process hub (CP/CS and air hose, without Ethernet)	3HAC069095-001	
Process hub, Clean Room (CP/CS and air hose, without Ethernet)	3HAC075510-001	Used with protection type Clean Room.
Process hub (CP/CS and air hose, with Ethernet)	3HAC069096-001	
Process hub, Clean Room (CP/CS and air hose, with Ethernet)	3HAC075511-001	Used with protection type Clean Room.
Extender unit	3HAC069037-001	Used for IRB 1100-4/0.58.
Extender unit, Clean Room	3HAC075508-001	Used for IRB 1100-4/0.58. Used with protection type Clean Room.

Continues on next page

5 Repair

5.6.2 Replacing the extender unit and wrist

Continued

Spare part	Article number	Note
Wrist	3HAC075794-001	
Wrist, IP67	3HAC075596-001	Used with protection class IP67.
Wrist, Clean Room	3HAC075512-001	Used with protection type Clean Room.
O-ring	3HAB3772-115	Used for IRB 1100-4/0.58 with protection class IP67 and project type Clean Room. Replace if damaged.
Gear unit with pulley, axis 4	3HAC073519-001	
O-ring on circular spline side	3HAC061327-009	Used with protection class IP67 and protection type Clean Room. Replace if damaged.
O-ring on flexible spline side	3HAB3772-115	Used with protection class IP67 and protection type Clean Room. Replace if damaged.
Motor with flange, axis 4	3HAC083586-001	
Timing belt, axis 4	3HAC061937-001	
Motor with flange, axis 5	3HAC083585-001	
Timing belt, axis 5	3HAC061938-001	
Motor with flange, axis 6	3HAC083584-001	
Timing belt, axis 6	3HAC061939-001	
Housing cover	3HAC069054-001	
Housing cover, Clean Room	3HAC075501-001	Used with protection type Clean Room.
Wrist cover	3HAC069061-001	
Wrist cover, Clean Room	3HAC075507-001	Used with protection type Clean Room.
Lower arm cover	3HAC069057-001	
Lower arm cover, Clean Room	3HAC075503-001	Used with protection type Clean Room.
Lower arm support cover	3HAC069059-001	
Lower arm support cover, Clean Room	3HAC075505-001	Used with protection type Clean Room.
Gasket for lower arm cover	3HAC061959-006	Used with protection class IP67 and protection type Clean Room. Replace if damaged.
Gasket for lower arm support cover	3HAC065331-001	Used with protection class IP67 and protection type Clean Room. Replace if damaged.
Gasket for housing cover	3HAC061959-007	Used with protection class IP67 and protection type Clean Room. Replace if damaged.
Gasket for wrist cover	3HAC061959-009	Used with protection class IP67 and protection type Clean Room. Replace if damaged.

Continues on next page

5.6.2 Replacing the extender unit and wrist

Continued

Spare part	Article number	Note
Cooling pad for axis-3 and -4 motors	3HAC071021-001	Cooling pads are wear parts. One cooling pad sheet includes 10 pieces of small pad. Replace if damaged with one piece each time.
Washer	3HAC063985-001	9x4.3x1, Steel
Washer	3HAC064765-001	7x3.2x1.5, Steel
Rubber sealing washer on housing	3HAC064147-001	Used with protection class IP67 and protection type Clean Room. Replace if damaged.
Rubber sealing washer on extender unit	3HAC067995-001	Used with protection class IP67 and protection type Clean Room. Replace if damaged.
Plug screw	3HAC064146-001	Used with protection classes IP40 and IP67. Replace if damaged.
Plug screw, Clean Room	3HAC070309-001	Used with protection type Clean Room. Replace if damaged.

Required tools and equipment

Equipment	Article number	Note
Standard toolkit	-	Content is defined in section Standard toolkit on page 733 .
Calibration tool box, Axis Calibration	3HAC074119-001	Delivered as a set of calibration tools. Required if Axis Calibration is the valid calibration method for the robot. The tool box also includes a unique calibration pin for IRB 1100 to be fitted to the tool flange during calibration of axis 6.
24 VDC power supply	-	Used to release the motor brakes.
Sonic tension meter	-	Used for measuring the timing belt tension.
Dynamometer	-	Used for measuring the timing belt tension.
axis-4 motor fitting tool	-	Included in the special toolkit 3HAC071022-001. Used to refit the axis-4 motor.
M3x25 eye bolt	-	Included in the special toolkit 3HAC071022-001.
J5.C2 connector assembly tool	-	Included in the special toolkit 3HAC071022-001. Used to remove and refit the J5.C2 connector, if the Ethernet cabling is equipped.

Continues on next page

5 Repair

5.6.2 Replacing the extender unit and wrist

Continued

Required consumables

Consumable	Article number	Note
Cable straps	-	
Grease	3HAC029132-001	FM 222
Locking liquid	-	Loctite 2400 (or equivalent Loctite 243)

Deciding calibration routine

Decide which calibration routine to be used, based on the information in the table. Depending on which routine is chosen, action might be required prior to beginning the repair work of the robot, see the table.

	Action	Note
1	Decide which calibration routine to use for calibrating the robot. <ul style="list-style-type: none">Reference calibration. External cable packages (DressPack) and tools can stay fitted on the robot.Fine calibration. All external cable packages (DressPack) and tools must be removed from the robot.	 Note Calibrating axis 6 always requires tools to be removed from the mounting flange (also for reference calibration) since the mounting flange is used for installation of the calibration tool.
	If the robot is to be calibrated with reference calibration: Find previous reference values for the axis or create new reference values. These values are to be used after the repair procedure is completed, for calibration of the robot. If no previous reference values exist, and no new reference values can be created, then reference calibration is not possible.	Follow the instructions given in the reference calibration routine on the FlexPendant to create reference values. Creating new values requires possibility to move the robot. Read more about reference calibration for Axis Calibration in Reference calibration routine on page 696 .
	If the robot is to be calibrated with fine calibration: Remove all external cable packages (DressPack) and tools from the robot.	



Removing the extender unit and wrist

Use these procedures to remove the extender unit and wrist.

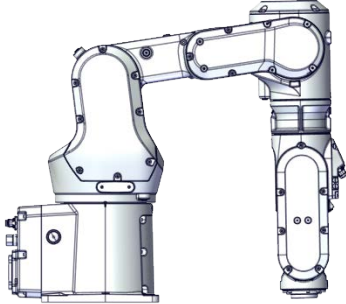

Preparations before removing the extender unit and wrist

	Action	Note
1	Decide which calibration routine to use, and take actions accordingly prior to beginning the repair procedure.	

Continues on next page

	Action	Note
2	<p>Jog the robot to the specified position:</p> <ul style="list-style-type: none"> • Axis 1: 0° • Axis 2: 110° (IRB 1100-4/0.475) /95° (IRB 1100-4/0.58) • Axis 3: -20° (IRB 1100-4/0.475)/ -6° (IRB 1100-4/0.58) • Axis 4: 0° • Axis 5: 0° • Axis 6: No significance. 	 <p>xx1800003289</p>
3	<p> DANGER</p> <p>Turn off all:</p> <ul style="list-style-type: none"> • electric power supply • hydraulic pressure supply • air pressure supply <p>to the robot, before entering the safeguarded space.</p>	
4	<p> CAUTION</p> <p>For robots with protection type Clean Room Always cut the paint with a knife and grind the paint edge when disassembling parts of the robot! See Cut the paint or surface on the robot before replacing parts on page 124.</p>	

Removing the process hub

	Action	Note
1	<p> DANGER</p> <p>Make sure that all supplies for electrical power, hydraulic pressure, and air pressure are turned off.</p>	
2	<p> CAUTION</p> <p>For robots with protection type Clean Room Always cut the paint with a knife and grind the paint edge when disassembling parts of the robot! See Cut the paint or surface on the robot before replacing parts on page 124.</p>	

Continues on next page

5 Repair

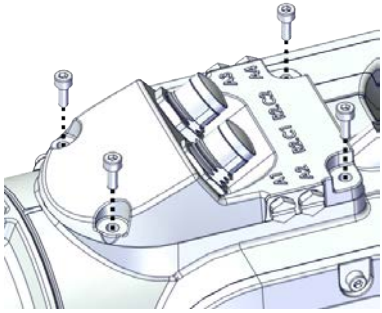
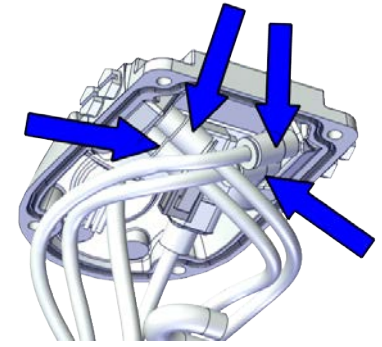
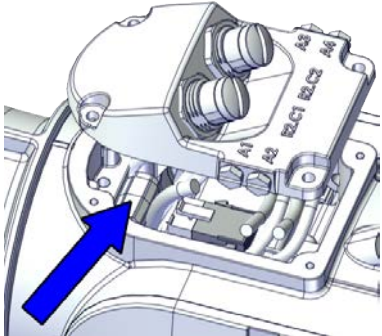
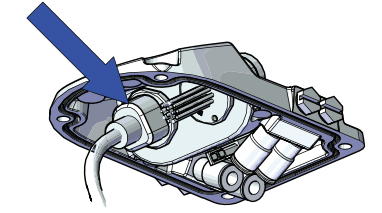

5.6.2 Replacing the extender unit and wrist

Continued



	Action	Note
3	<p>Remove the screws and carefully open the cover.</p> <p> CAUTION</p> <p>Be aware of the cabling that is attached to the cover! The cover can not be removed completely until the connectors are disconnected, as shown in following steps.</p>	 <p>xx1800002944</p>
4	<p>Disconnect the air hoses.</p>	 <p>xx1800002945</p>
5	<p>For robots with CP/CS cabling Disconnect the connector.</p> <ul style="list-style-type: none"> • J5.C1 	 <p>xx1800002947</p>
6	<p>For robots with Ethernet cabling Disconnect the connector J5.C2 using the tool.</p>	<p>J5.C2 connector assembly tool: -</p>  <p>xx1800002948</p>

Continues on next page

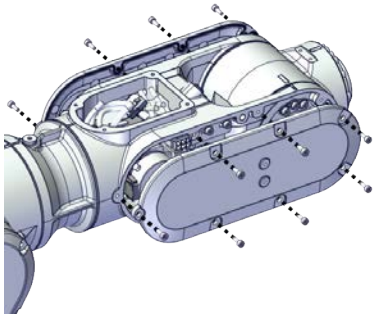
Removing the wrist covers

	Action	Note
1	 DANGER Make sure that all supplies for electrical power, hydraulic pressure, and air pressure are turned off.	
2	 CAUTION For robots with protection type Clean Room Always cut the paint with a knife and grind the paint edge when disassembling parts of the robot! See Cut the paint or surface on the robot before replacing parts on page 124 .	
3	Remove the wrist covers from both sides.	 xx1800002949

Disconnecting the axis-5 motor connectors

	Action	Note
1	 DANGER Make sure that all supplies for electrical power, hydraulic pressure, and air pressure are turned off.	
2	 CAUTION For robots with protection type Clean Room Always cut the paint with a knife and grind the paint edge when disassembling parts of the robot! See Cut the paint or surface on the robot before replacing parts on page 124 .	

Continues on next page



5 Repair

5.6.2 Replacing the extender unit and wrist

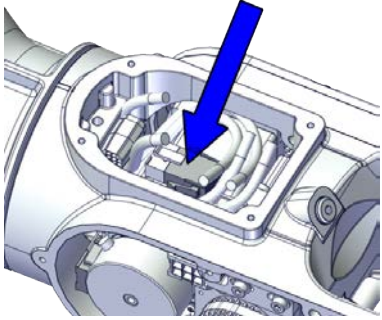
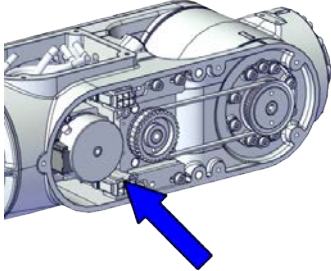
Continued

	Action	Note
3	Access the connector FB5 from the process hub and disconnect the connector.	 xx1800002950
4	Disconnect the connector. <ul style="list-style-type: none"> • MP5 	 xx1800002993



Disconnecting the axis-6 motor connectors

	Action	Note
1	 DANGER Make sure that all supplies for electrical power, hydraulic pressure, and air pressure are turned off.	
2	 CAUTION For robots with protection type Clean Room Always cut the paint with a knife and grind the paint edge when disassembling parts of the robot! See Cut the paint or surface on the robot before replacing parts on page 124.	

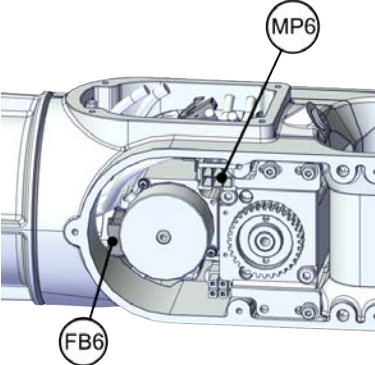
Continues on next page

	Action	Note
3	Disconnect the connectors. <ul style="list-style-type: none"> • MP6 • FB6 	 <p>xx1800002994</p>

Removing the axis-6 motor

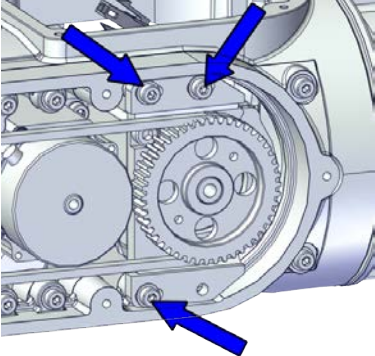
	Action	Note
1	 DANGER Make sure that all supplies for electrical power, hydraulic pressure, and air pressure are turned off.	
2	 CAUTION For robots with protection type Clean Room Always cut the paint with a knife and grind the paint edge when disassembling parts of the robot! See Cut the paint or surface on the robot before replacing parts on page 124.	
3	 CAUTION Removing motors will release axes. This means the axes can fall down. Make sure axes are well supported before removing motors.	
4	Loosen the screws and move the motor slightly to slacken the timing belt.	 <p>xx1800002995</p>

Continues on next page



5 Repair

5.6.2 Replacing the extender unit and wrist

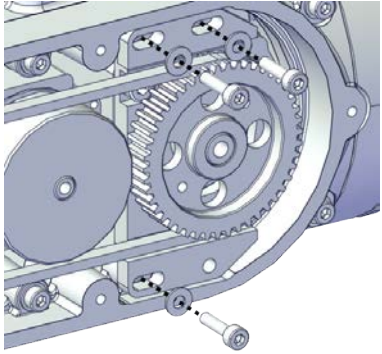
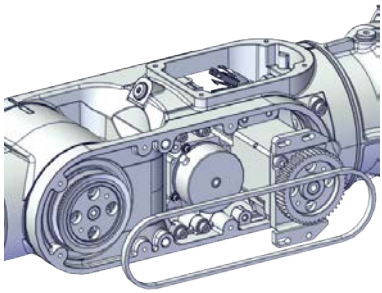
Continued

	Action	Note
5	Remove the screws and washers.	 xx1800002996
6	Carefully lift out the motor.	
7	Remove the timing belt from its groove on the motor.	 xx1800002997

Removing the axis-5 motor

	Action	Note
1	 DANGER Make sure that all supplies for electrical power, hydraulic pressure, and air pressure are turned off.	
2	 CAUTION For robots with protection type Clean Room Always cut the paint with a knife and grind the paint edge when disassembling parts of the robot! See Cut the paint or surface on the robot before replacing parts on page 124.	
3	 CAUTION Removing motors will release axes. This means the axes can fall down. Make sure axes are well supported before removing motors.	

Continues on next page

5.6.2 Replacing the extender unit and wrist
Continued

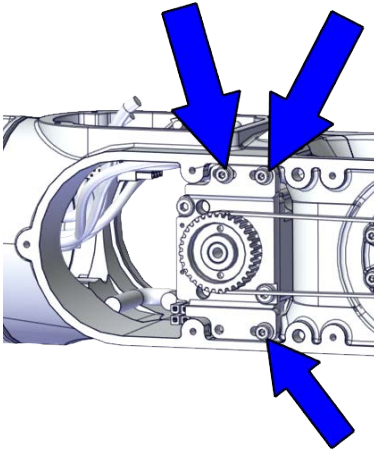
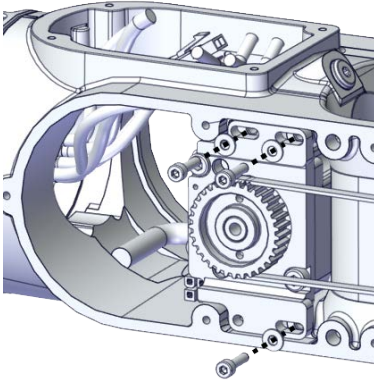
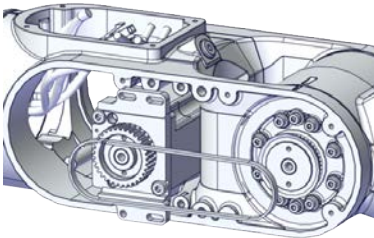
	Action	Note
4	Loosen the screws and move the motor slightly to slacken the timing belt.	 <p>xx1800003293</p>
5	Remove the screws and washers.	 <p>xx1800003294</p>
6	Carefully lift out the motor.	
7	Remove the timing belt from its groove on the motor.	 <p>xx1800003295</p>



Continues on next page

5 Repair

5.6.2 Replacing the extender unit and wrist

Continued

Loosening the cable package from axis-4 gearbox

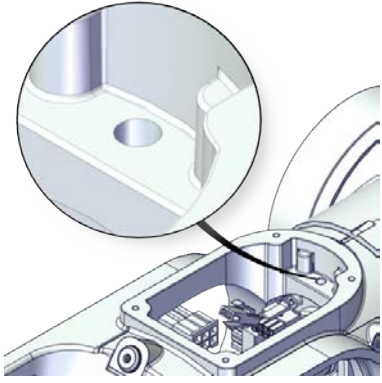
	Action	Note
1	 DANGER Make sure that all supplies for electrical power, hydraulic pressure, and air pressure are turned off.	
2	 CAUTION For robots with protection type Clean Room Always cut the paint with a knife and grind the paint edge when disassembling parts of the robot! See Cut the paint or surface on the robot before replacing parts on page 124 .	
3	Valid for IRB 1100-4/0.475 Access the cable package locking screw on the axis-4 gearbox from the wrist and then loosen the locking screw.	 xx1800003031



Continues on next page

5.6.2 Replacing the extender unit and wrist

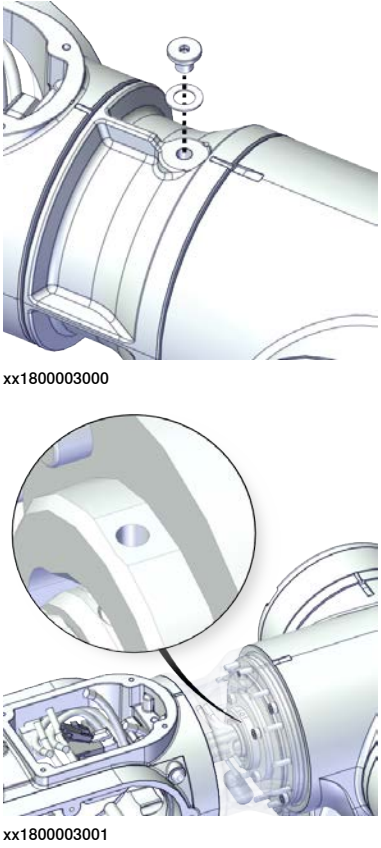
Continued

	Action	Note
4	Remove the plug screw and washer on the extender unit to access the cable package locking screw on the axis-4 gearbox and then loosen the locking screw.	 <p>xx1800003000</p> <p>xx1800003001</p>

Disconnecting the axis-4 motor connectors

	Action	Note
1	 <p>DANGER</p> <p>Make sure that all supplies for electrical power, hydraulic pressure, and air pressure are turned off.</p>	
2	 <p>CAUTION</p> <p>For robots with protection type Clean Room Always cut the paint with a knife and grind the paint edge when disassembling parts of the robot! See Cut the paint or surface on the robot before replacing parts on page 124.</p>	

Continues on next page



5 Repair

5.6.2 Replacing the extender unit and wrist

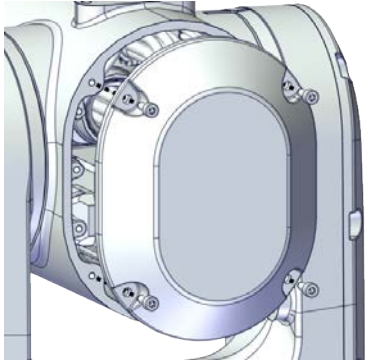
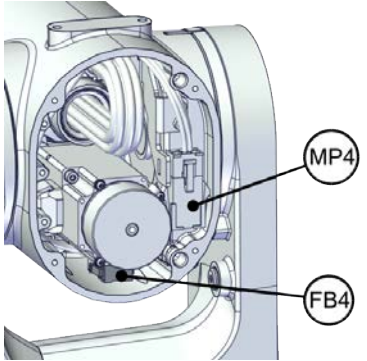
Continued

	Action	Note
3	Remove the housing cover.	 xx1800003011
4	Disconnect the motor connectors. <ul style="list-style-type: none"> • FB4 • MP4 	 xx1800003012

Separating the upper cable package from the housing



	Action	Note
1	 DANGER Make sure that all supplies for electrical power, hydraulic pressure, and air pressure are turned off.	
2	 CAUTION For robots with protection type Clean Room Always cut the paint with a knife and grind the paint edge when disassembling parts of the robot! See Cut the paint or surface on the robot before replacing parts on page 124.	

Continues on next page

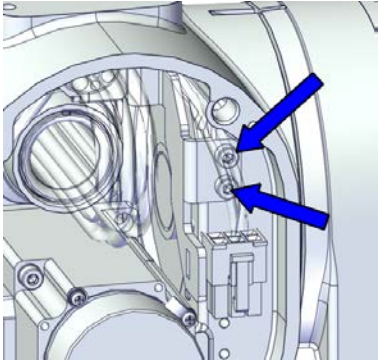
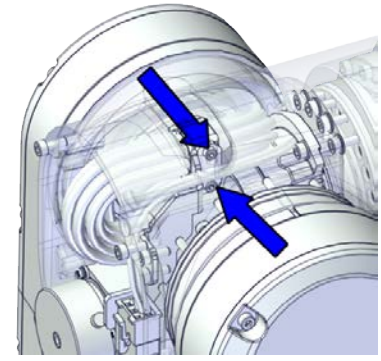
5.6.2 Replacing the extender unit and wrist
Continued

	Action	Note
3	Remove the cable bracket.	 <p>xx1800003013</p>  <p>xx1800003014</p>

Pulling out the upper cable harness

	Action	Note
1	 DANGER Make sure that all supplies for electrical power, hydraulic pressure, and air pressure are turned off.	
2	 CAUTION For robots with protection type Clean Room Always cut the paint with a knife and grind the paint edge when disassembling parts of the robot! See Cut the paint or surface on the robot before replacing parts on page 124.	

Continues on next page



5 Repair

5.6.2 Replacing the extender unit and wrist

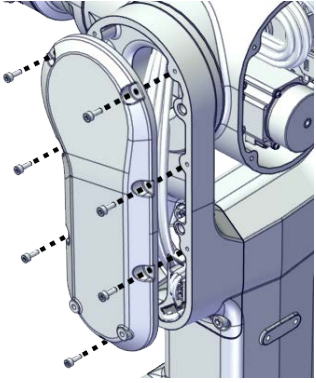
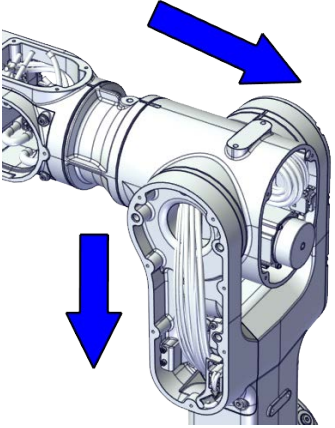

Continued

	Action	Note
3	Remove the lower arm support cover.	 <p>xx1800003092</p>
4	Pull out the upper cable harness from the housing, out from the lower arm support.	 <p>xx1800003093</p>

Removing the axis-4 motor

	Action	Note
1	 <p>DANGER</p> <p>Make sure that all supplies for electrical power, hydraulic pressure, and air pressure are turned off.</p>	
2	 <p>CAUTION</p> <p>For robots with protection type Clean Room Always cut the paint with a knife and grind the paint edge when disassembling parts of the robot! See Cut the paint or surface on the robot before replacing parts on page 124.</p>	
3	 <p>CAUTION</p> <p>Removing motors will release axes. This means the axes can fall down. Make sure axes are well supported before removing motors.</p>	

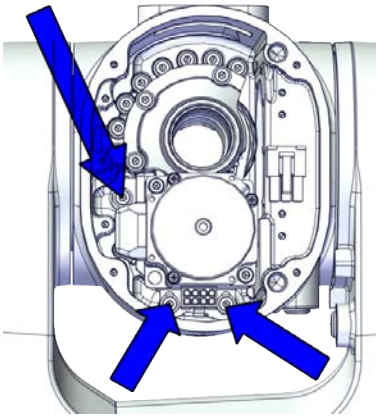
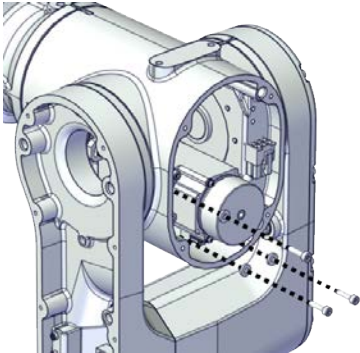
Continues on next page

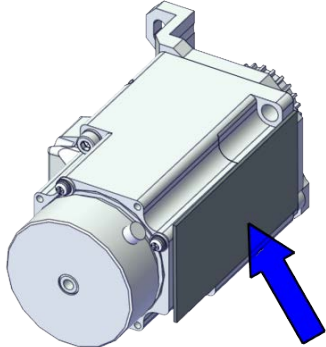
	Action	Note
4	Loosen the screws and move the motor slightly to slacken the timing belt.	 <p>xx1800003094</p>
5	Remove the screws and washers.	 <p>xx1800003095</p>
6	<p>Carefully lift out the motor.</p> <p> CAUTION</p> <p>A cooling pad is attached to the motor, which may stick to the casting. Always use a plastic sheet with caution to remove the pad from the casting. Pay attention not to scratch the casting or damage the pad.</p>	<p>Cooling pad location</p>  <p>xx1800003605</p>

Continues on next page



5 Repair

5.6.2 Replacing the extender unit and wrist

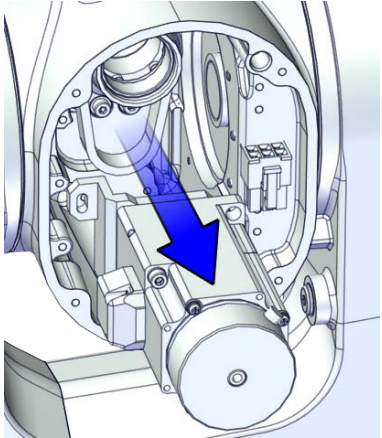
Continued

	Action	Note
7	Remove the timing belt from its groove on the motor.	 <p>xx1800003096</p>

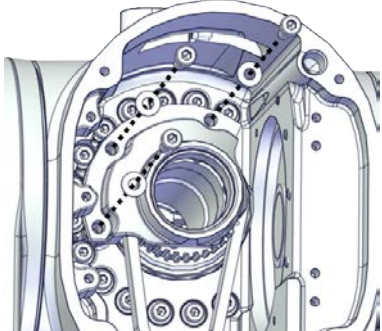

Removing the pulley cover and axis-4 timing belt

	Action	Note
1	 DANGER Make sure that all supplies for electrical power, hydraulic pressure, and air pressure are turned off.	
2	 CAUTION For robots with protection type Clean Room Always cut the paint with a knife and grind the paint edge when disassembling parts of the robot! See Cut the paint or surface on the robot before replacing parts on page 124.	
3	 CAUTION Loosening timing belts will release axes. This means the axes can fall down. Make sure axes are well supported before loosening timing belts.	
4	Remove the pulley cover.	 <p>xx1800003097</p>

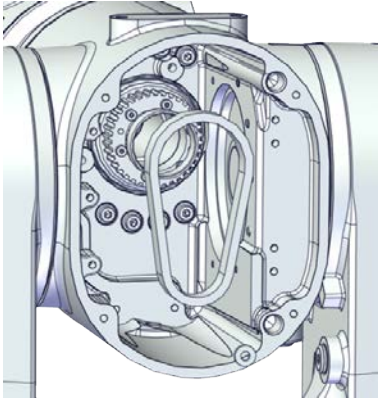
Continues on next page

	Action	Note
5	Remove the timing belt from its groove on the gearbox.	 <p>xx1800003098</p>

Separating the housing

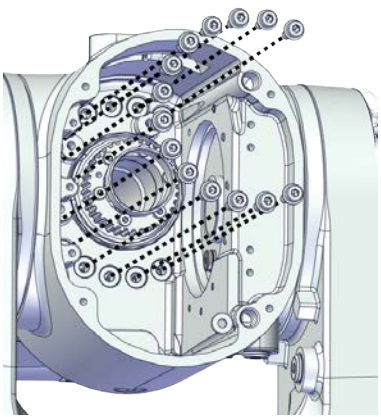
	Action	Note
1	 <p>DANGER</p> <p>Make sure that all supplies for electrical power, hydraulic pressure, and air pressure are turned off.</p>	
2	 <p>CAUTION</p> <p>For robots with protection type Clean Room Always cut the paint with a knife and grind the paint edge when disassembling parts of the robot! See Cut the paint or surface on the robot before replacing parts on page 124.</p>	
3	<p>Remove the screws.</p>  <p>Note</p> <p>Some robots may be fitted with separate screws and washers. During replacement, always use the same screws (and washers) that are fitted on the robot at delivery. Contact ABB for more information.</p>	 <p>xx1900002191</p>

Continues on next page



5 Repair

5.6.2 Replacing the extender unit and wrist

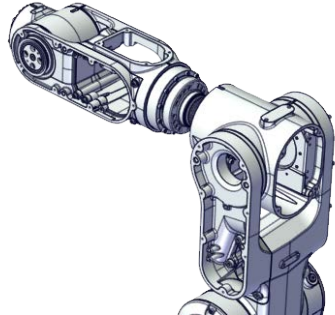
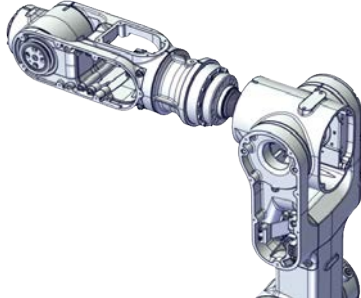
Continued

	Action	Note
4	Valid for IRB 1100-4/0.475 Separate the wrist from the housing.	 xx1800003299
5	Separate the extender unit and wrist from the housing.	 xx1800003298

Removing the axis-4 gearbox



	Action	Note
1	 DANGER Make sure that all supplies for electrical power, hydraulic pressure, and air pressure are turned off.	
2	 CAUTION For robots with protection type Clean Room Always cut the paint with a knife and grind the paint edge when disassembling parts of the robot! See Cut the paint or surface on the robot before replacing parts on page 124.	
3	 CAUTION Removing gearboxes will release axes. This means the axes can fall down. Make sure axes are well supported before removing gearboxes.	

Continues on next page

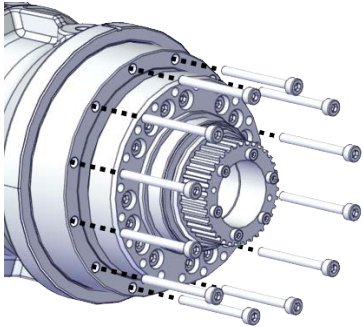
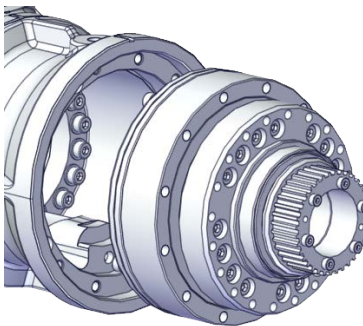
5.6.2 Replacing the extender unit and wrist
Continued

	Action	Note
4	Remove the screws.	 <p>xx1800003300</p>
5	Pull out the gearbox.	 <p>xx1800003310</p>

Separating the extender unit and wrist

	Action	Note
1	 <p>DANGER</p> <p>Make sure that all supplies for electrical power, hydraulic pressure, and air pressure are turned off.</p>	
2	 <p>CAUTION</p> <p>For robots with protection type Clean Room Always cut the paint with a knife and grind the paint edge when disassembling parts of the robot! See Cut the paint or surface on the robot before replacing parts on page 124.</p>	

Continues on next page

5 Repair

5.6.2 Replacing the extender unit and wrist

Continued

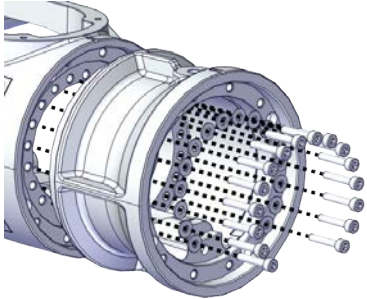
	Action	Note
3	Separate the extender unit from the wrist.	 <p>xx1800003311</p>

Refitting the extender unit and wrist

Use these procedures to refit the extender unit and wrist.

Refitting the extender unit to the wrist

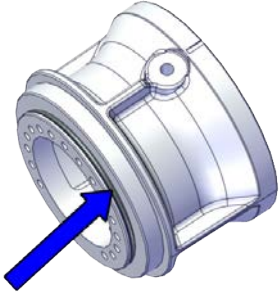
	Action	Note
1	For robots with protection type Clean Room: Clean the joints that have been opened and wipe the parts free from particles with spirit on a lint free.	
2	For robots with protection class IP67 (option 3350-670) For robots with protection type Clean Room (option 3351-4) Check the O-ring. Replace if damaged.	<p>O-ring: 3HAB3772-115</p>  <p>xx1900002193</p>

Continues on next page

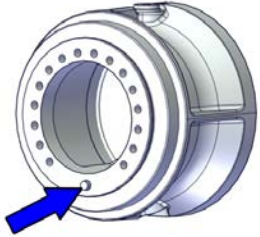
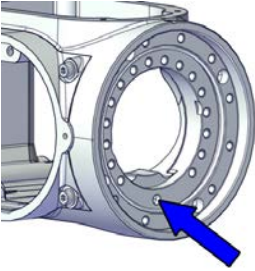
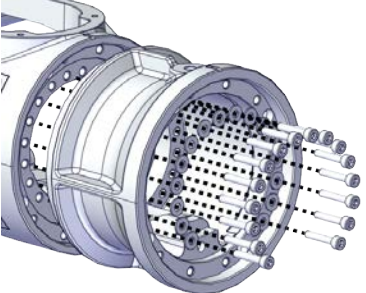
	Action	Note
3	<p>Align the parallel pin on the extender unit with the pin hole on the wrist.</p> <p> Note</p> <p>Some robots may not have the parallel pin. In those cases, order one and press fit it to the extender unit.</p>	<p>Parallel pin: 3HAC050369-032</p>  <p>xx2100001504</p>  <p>xx2100001505</p>
4	<p>Refit the extender unit to the wrist.</p>	<p>Screw: M3x16 12.9 Lafre 2C2B/FC6.9 (16 pcs)</p> <p>Tightening torque: 2 Nm</p>  <p>xx1800003311</p>

Refitting the axis-4 gearbox

	Action	Note
1	<p>For robots with protection type Clean Room: Clean the joints that have been opened and wipe the parts free from particles with spirit on a lint free.</p>	

5 Repair

5.6.2 Replacing the extender unit and wrist

Continued

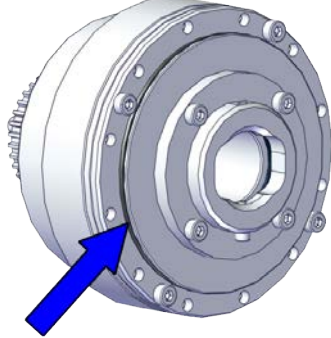
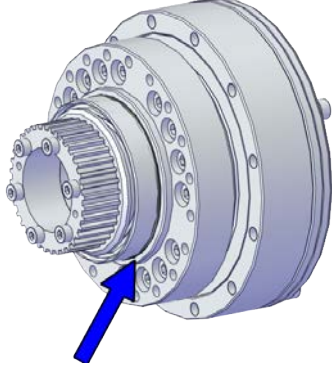
	Action	Note
2	<p>For robots with protection class IP67 (option 3350-670) For robots with protection type Clean Room (option 3351-4) Check the O-rings. Replace if damaged.</p>	<p>O-ring on flexible spline side: 3HAB3772-115</p>  <p>xx1900002199</p> <p>O-ring on circular spline side: 3HAC061327-009</p>  <p>xx1900002198</p>

Continues on next page

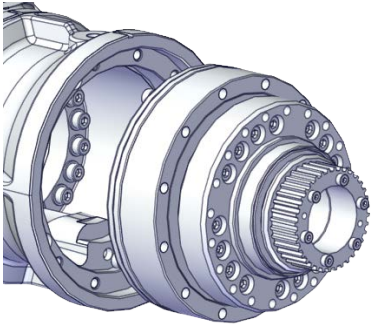
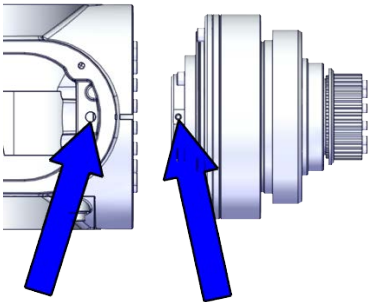
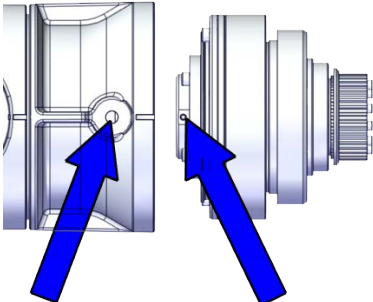
	Action	Note
3	<p>Refit the axis-4 gearbox. Make sure the locking screw holes on the gearbox and extender unit or wrist are aligned with each other.</p>	 <p>xx1800003310</p> <p>Valid for IRB 1100-4/0.475</p>  <p>xx1800003313</p>  <p>xx1800003312</p>

Continues on next page

5 Repair

5.6.2 Replacing the extender unit and wrist

Continued

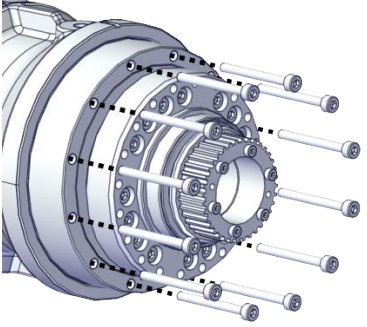
	Action	Note
4	Secure with screws.	<p>Screw: M3x30 12.9 Lafre 2C2B/FC6.9 (12 pcs) Tightening torque: 1.8 Nm</p>  <p>xx1800003300</p>

Refitting the housing

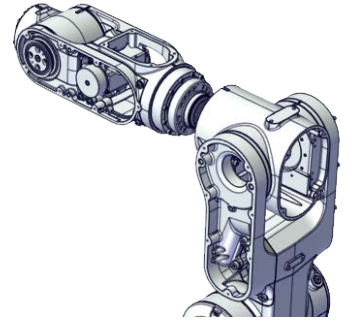
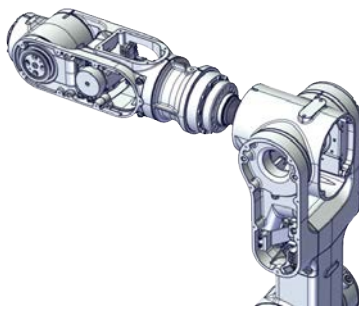
	Action	Note
1	For robots with protection type Clean Room: Clean the joints that have been opened and wipe the parts free from particles with spirit on a lint free.	
2	Valid for IRB 1100-4/0.475 Refit the the wrist to the housing.	 <p>xx1800003075</p>
3	Refit the extender unit and wrist to the housing.	 <p>xx1800003100</p>

Continues on next page

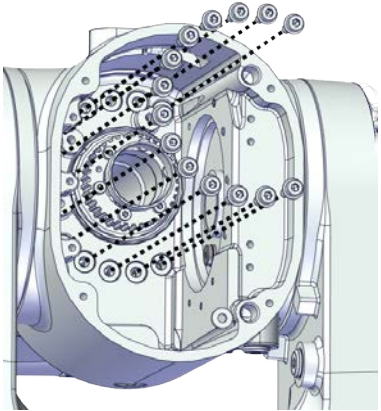
	Action	Note
4	<p>Refit the screws and washers.</p> <p> Note</p> <p>Some robots may be fitted with separate screws and washers. During replacement, always use the same screws (and washers) that are fitted on the robot at delivery. Contact ABB for more information.</p>	<p>Flange screws (14 pcs)</p> <p>For robots with protection class IP40</p> <p>Tightening torque: 1.9 Nm</p> <p>For robots with protection class IP67</p> <p>For robots with protection type Clean Room</p> <p>Tightening torque: 1.8 Nm</p>  <p>xx1900002191</p>

Refitting the axis-4 timing belt and pulley cover

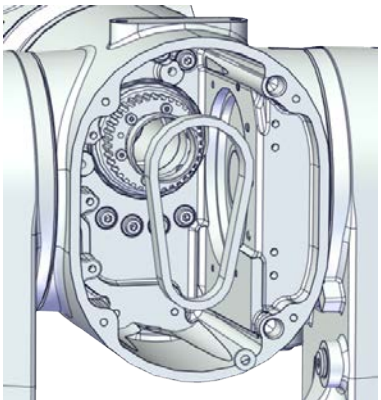
	Action	Note
1	<p>For robots with protection type Clean Room:</p> <p>Clean the joints that have been opened and wipe the parts free from particles with spirit on a lint free.</p>	
2	<p>Install the timing belt to the gearbox pulley and verify that the belt runs correctly in the groove of the pulley.</p>	 <p>xx1800003098</p>

Continues on next page

5 Repair

5.6.2 Replacing the extender unit and wrist

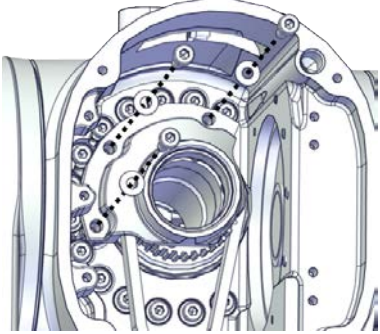

Continued

	Action	Note
3	Refit the pulley cover.	<p>Screw: M3x8 12.9 Lafre 2C2B/FC6.9 (3 pcs) Tightening torque: 1.2 Nm</p>  <p>xx1800003097</p>

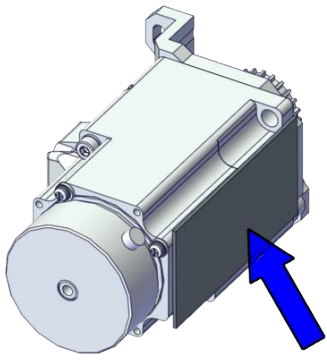
Refitting the axis-4 motor

	Action	Note
1	For robots with protection type Clean Room: Clean the joints that have been opened and wipe the parts free from particles with spirit on a lint free.	
2	Check that: <ul style="list-style-type: none"> • all assembly surfaces are clean and without damages • the motor is clean and undamaged. 	
3	Check the cooling pad. Replace if damaged.	<p>Cooling pad for axis-3 and -4 motors: 3HAC071021-001</p>  <p>xx1800003605</p>

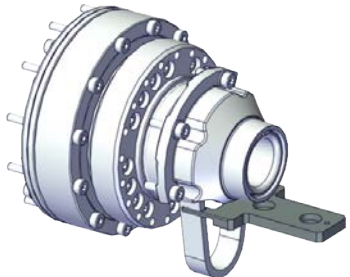
Continues on next page

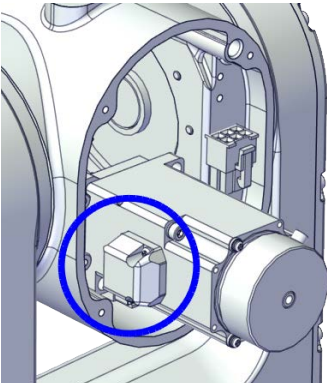
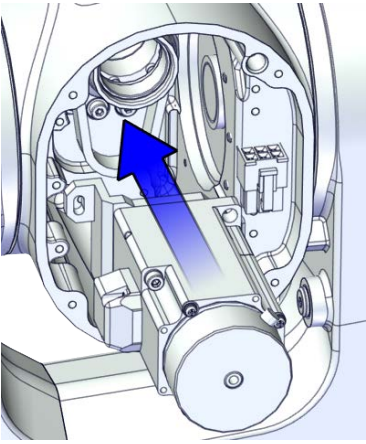
	Action	Note
4	Use the motor fitting tool to fix the timing belt.	<p>axis-4 motor fitting tool, included in the special toolkit 3HAC071022-001.</p>  <p>xx1900000044</p>
5	<p>Orient the motor correctly and fit it into the housing.</p> <p> Note</p> <p>Make sure the motor flange does not press on the timing belt.</p>	<p>Motor orientation: orient the motor according to the figure below, in regard to the encircled motor connector.</p>  <p>xx1800003287</p>
6	Install the timing belt to the motor pulley.	 <p>xx1800003617</p>

Continues on next page

5 Repair

5.6.2 Replacing the extender unit and wrist

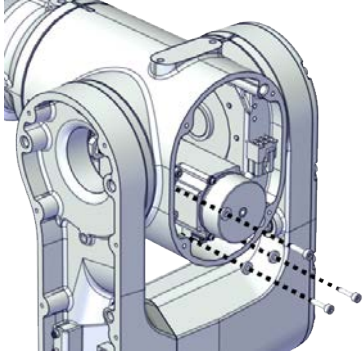

Continued

	Action	Note
7	Refit the screws and washers.  Note Do not tighten the screws yet.	Screw: M3x12 12.9 Lafre 2C2B/FC6.9 (3 pcs) Washer, 3HAC064765-001 (3 pcs)  xx1800003095
8	Remove the motor fitting tool.	

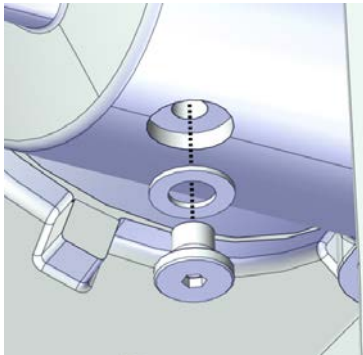
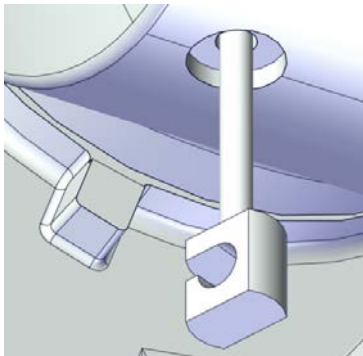
Adjusting the axis-4 timing belt tension

	Action	Note
1	For robots with protection type Clean Room: Clean the joints that have been opened and wipe the parts free from particles with spirit on a lint free.	
2	Remove the screw and washer below the housing.	 xx1900000036
3	Fit an M3x25 eye bolt to the screw hole.	 xx1900000037

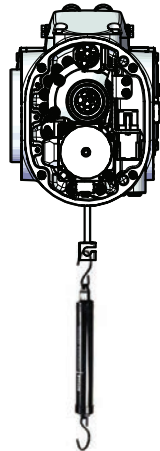
Continues on next page

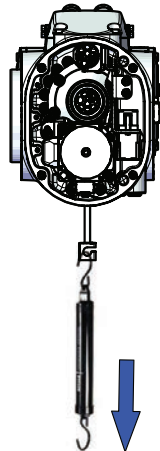
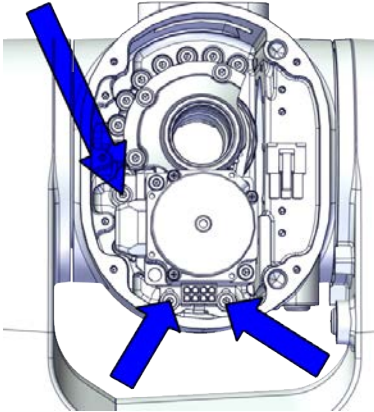
	Action	Note
4	Use a handheld dynamometer hooking to the eye bolt.	 <p>xx190000038</p>
5	Pull the dynamometer to make the tension falling in the allowed force range.  Note Pay attention to the force application direction.	Used belt: 20.09-22.05 N New belt: 28.7-31.5 N  <p>xx190000039</p>
6	Secure the motor with the screws.	Tightening torque: 1.4 Nm  <p>xx1800003094</p>

Continues on next page



5 Repair

5.6.2 Replacing the extender unit and wrist

Continued

	Action	Note
7	Remove eye bolt and refit the screw and washer below the housing.	<p>Plug screw: 3HAC064146-001</p> <p>For robots with protection type Clean Room (option 3351-4)</p> <p>Plug screw, Clean Room: 3HAC070309-001</p> <p>For robots with protection class IP67 (option 3350-670)</p> <p>For robots with protection type Clean Room (option 3351-4)</p> <p>Rubber sealing washer on housing: 3HAC064147-001</p> <p>Tightening torque: 2 Nm</p>

Refitting the upper cable harness through the axis-4 gearbox

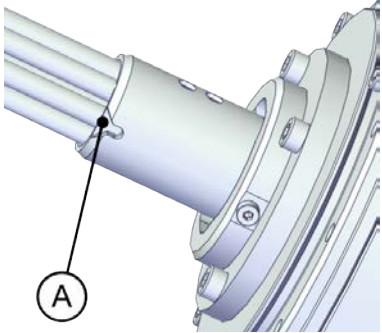
	Action	Note
1	For robots with protection type Clean Room: Clean the joints that have been opened and wipe the parts free from particles with spirit on a lint free.	
2	<p>Insert the cable package from the lower arm support, into the housing and through the axis-4 gearbox.</p> <p> Tip</p> <p>Wrap the connectors with the masking tape.</p> <p> CAUTION</p> <p>Make sure that no cables or hoses are twisted or strained. Reroute if necessary.</p>	<p>Cable protection tube orientation: use the notch (A) on the cable protection tube as a reference when inserting the cable package, which should be at the opposite direction to the locking screw hole on the gearbox.</p>  <p>xx1800003017</p>

Securing the upper cable package to the axis-4 gearbox

	Action	Note
1	For robots with protection type Clean Room: Clean the joints that have been opened and wipe the parts free from particles with spirit on a lint free.	

Continues on next page

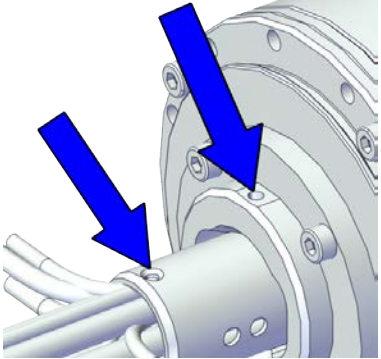
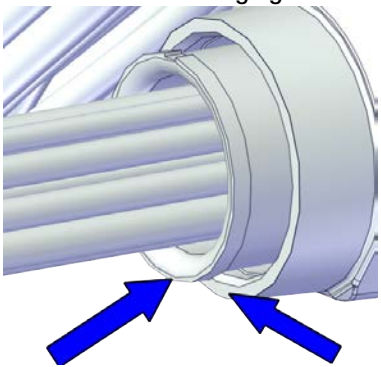
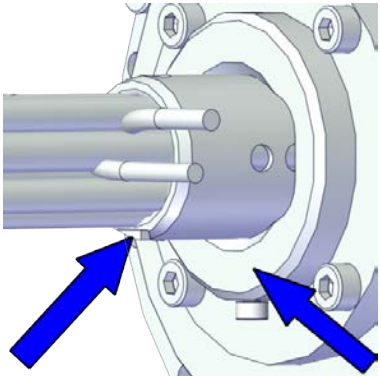

	Action	Note
2	<p>Make sure that:</p> <ul style="list-style-type: none"> • The hole on the cable protection tube is aligned with the locking screw hole on the gearbox. • The cable protection tube surface is completely parallel with the pulley cover at one side and with the flange at the other side. 	<p>Holes to be aligned are shown in the following figure.</p>  <p>xx1800003018</p> <p>Surfaces to be paralleled are shown in the following figures.</p>  <p>xx1800003019</p>  <p>xx1800003020</p>

Continues on next page

5 Repair

5.6.2 Replacing the extender unit and wrist

Continued

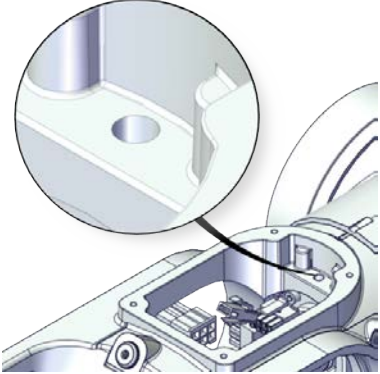
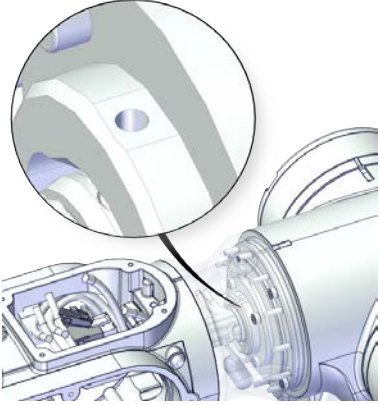
	Action	Note
3	<p>Apply a little Loctite 243 to the locking screw and refit the locking screw.</p> <p> Note</p> <p>Make sure the locking screw header is parallel with flange surface.</p> <p> Note</p> <p>If there is locking liquid residues on the screw or screw hole, please clean it before refitting. Remove residual locking liquid after refitting.</p>	<p>Screw: M3x8 (1 pcs) Tightening torque: 0.4 Nm Valid for IRB 1100-4/0.475</p>  <p>xx1800003031</p>  <p>xx1800003001</p>

Continues on next page

5.6.2 Replacing the extender unit and wrist

Continued

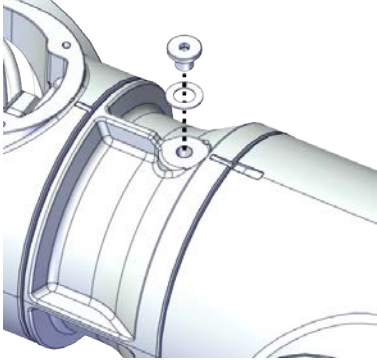
	Action	Note
4	Refit the plug screw and washer on the extender unit.	<p>Plug screw: 3HAC064146-001</p> <p>For robots with protection type Clean Room (option 3351-4)</p> <p>Plug screw, Clean Room: 3HAC070309-001</p> <p>For robots with protection class IP67 (option 3350-670)</p> <p>For robots with protection type Clean Room (option 3351-4)</p> <p>Rubber sealing washer on extender unit: 3HAC067995-001</p> <p>Tightening torque: 2 Nm</p>  <p>xx1800003000</p>

Securing the upper cable package to the housing



	Action	Note
1	For robots with protection type Clean Room: Clean the joints that have been opened and wipe the parts free from particles with spirit on a lint free.	

Continues on next page

5 Repair

5.6.2 Replacing the extender unit and wrist

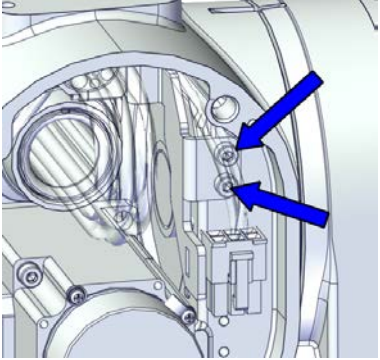
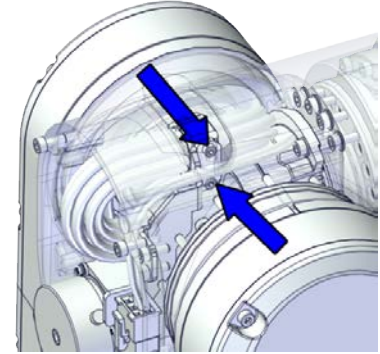

Continued

	Action	Note
2	Refit the cable bracket.	<p>Screw: M3x8 12.9 Lafre 2C2B/FC6.9 (2 pcs) Tightening torque: 0.8 Nm</p>  <p>xx1800003013</p> <p>Screw: M2.5x6 12.9 Lafre 2C2B/FC6.9 (2 pcs) Tightening torque: 0.6 Nm</p>  <p>xx1800003014</p>
3	<p>Route and secure the cabling with cable straps.</p> <p> CAUTION</p> <p>Correct cable routing is highly important. If the cables are routed and secured incorrectly the cables can be damaged.</p>	

Reconnecting the axis-4 motor connectors

	Action	Note
1	<p>For robots with protection type Clean Room: Clean the joints that have been opened and wipe the parts free from particles with spirit on a lint free.</p>	

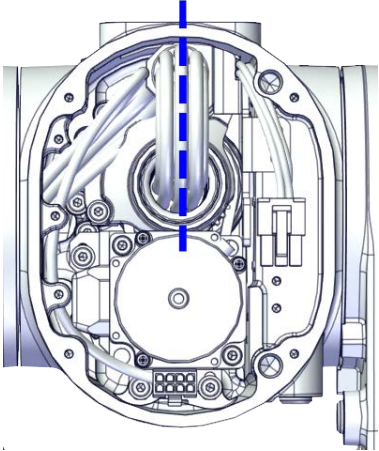
Continues on next page

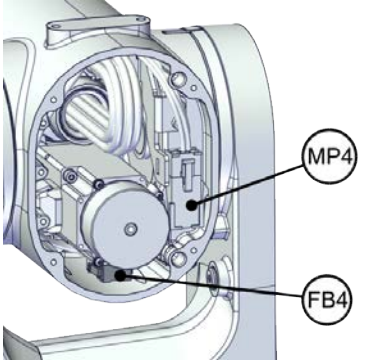
	Action	Note
2	<p>Check the cabling status. Make sure the cabling is in vertical state and is not twisted.</p>	 <p>xx1800003618</p>
3	<p>Reconnect the connectors.</p> <ul style="list-style-type: none"> • FB4 • MP4 <p> Tip</p> <p>See the number markings on the connectors for help to find the corresponding connector.</p>	 <p>xx1800003012</p>



Refitting the axis-5 motor

	Action	Note
1	<p>For robots with protection type Clean Room: Clean the joints that have been opened and wipe the parts free from particles with spirit on a lint free.</p>	
2	<p>Check that:</p> <ul style="list-style-type: none"> • all assembly surfaces are clean and without damages • the motor is clean and undamaged. 	

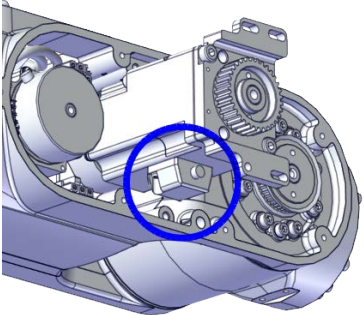

5 Repair

5.6.2 Replacing the extender unit and wrist

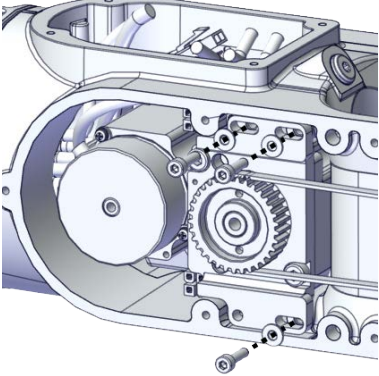
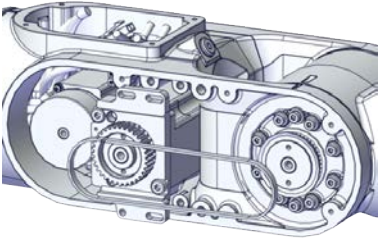
Continued

	Action	Note
3	<p>Orient the motor correctly and fit it into the wrist.</p> <p> Tip</p> <p>Leave the connectors FB5 and FB6 accessible from the process hub and the connectors MP5 and MP6 accessible from wrist side.</p>	<p>Motor orientation: orient the motor according to the figure below, in regard to the encircled motor connector.</p>  <p>xx1800003296</p>
4	<p>Refit the screws and washers.</p> <p> Note</p> <p>Do not tighten the screws yet.</p>	<p>Screw: M3x12 12.9 Lafre 2C2B/FC6.9 (3 pcs)</p>  <p>xx1800003291</p>
5	<p>Install the timing belt to the pulleys and verify that the belt runs correctly in the grooves of the pulleys.</p>	 <p>xx1800003292</p>

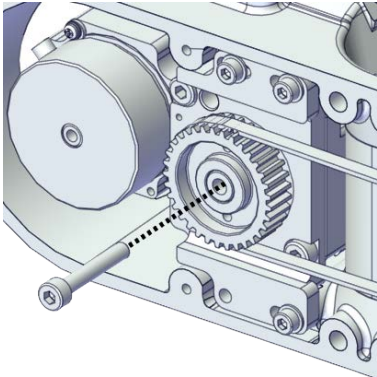
Continues on next page

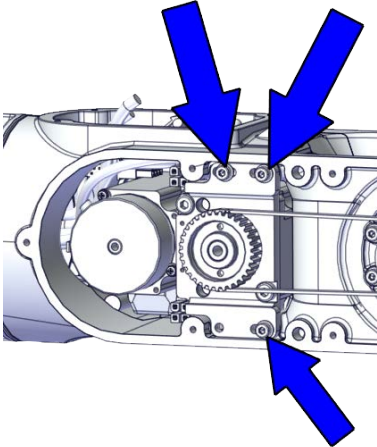
	Action	Note
6	Install an M4x25 or longer adjustment screw to the motor.  Note Do not insert the entire screw to the hole.	 xx190000008
7	Use a handheld dynamometer hooking to the screw and pull the dynamometer to reach the initial referenced force.	Initial referenced force for used belt: 13.58-14.84 N (for reference only) Initial referenced force for new belt: 19.4-21.2 N  xx190000027
8	Secure the motor with the screws.	Tightening torque: 1.4 Nm  xx1800003290
9	Use a sonic tension meter to measure the timing belt tension.	Used belt: 151-162 Hz New belt: 167-213 Hz (for reference only)
10	If the timing belt tension does not meet the requirement, loosen the motor screws and readjust.	

Continues on next page

5 Repair

5.6.2 Replacing the extender unit and wrist

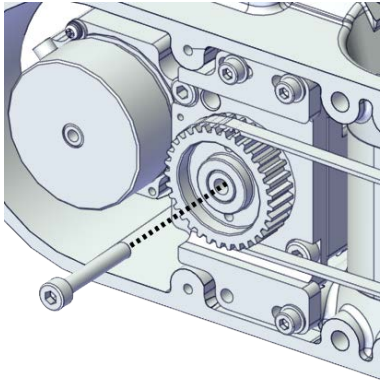

Continued

	Action	Note
11	Remove the adjustment screw from the motor.	 <p>xx190000008</p>

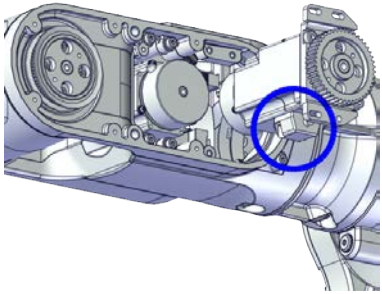
Refitting the axis-6 motor

	Action	Note
1	For robots with protection type Clean Room: Clean the joints that have been opened and wipe the parts free from particles with spirit on a lint free.	
2	Check that: <ul style="list-style-type: none"> • all assembly surfaces are clean and without damages • the motor is clean and undamaged. 	
3	<p>Orient the motor correctly and fit it into the lower arm.</p> <p> Tip</p> <p>Leave the connectors FB5 and FB6 accessible from the process hub and the connectors MP5 and MP6 accessible from wrist side.</p>	<p>Motor orientation: orient the motor according to the figure below, in regard to the encircled motor connector.</p>  <p>xx1800003023</p>

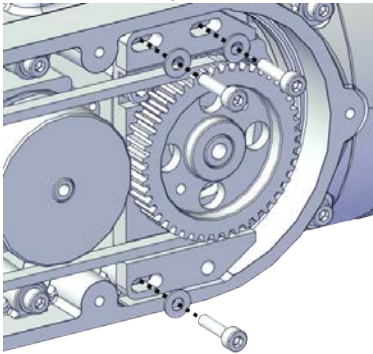
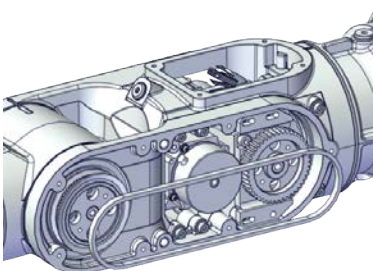
Continues on next page

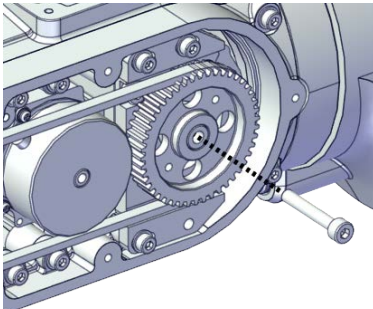
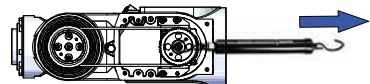
	Action	Note
4	Refit the screws and washers.  Note Do not tighten the screws yet.	Screw: M3x12 12.9 Lafre 2C2B/FC6.9 (3 pcs)  xx1800002996
5	Install the timing belt to the pulleys and verify that the belt runs correctly in the grooves of the pulleys.	 xx1800003024
6	Install an M4x25 or longer adjustment screw to the motor.  Note Do not insert the entire screw to the hole.	 xx1900000007
7	Use a handheld dynamometer hooking to the screw and pull the dynamometer to reach the initial referenced force.	Initial referenced force for used belt: 8.96-9.8 N (for reference only) Initial referenced force for new belt: 12.8-14  xx1900000026

Continues on next page

5 Repair

5.6.2 Replacing the extender unit and wrist

Continued

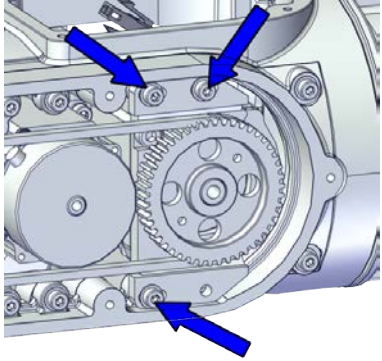
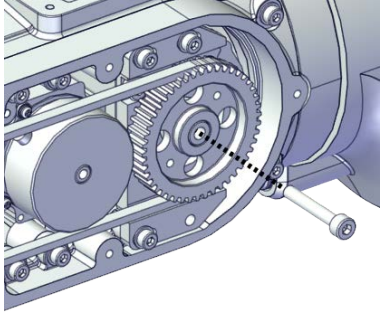

	Action	Note
8	Secure the motor with the screws.	<p>Tightening torque: 1.4 Nm</p>  <p>xx1800002995</p>
9	Use a sonic tension meter to measure the timing belt tension.	<p>Used belt: 81.3-86.9 Hz New belt: 90-114 Hz (for reference only)</p>
10	If the timing belt tension does not meet the requirement, loosen the motor screws and readjust.	
11	Remove the adjustment screw from the motor.	 <p>xx1900000007</p>

Reconnecting the axis-6 motor connectors

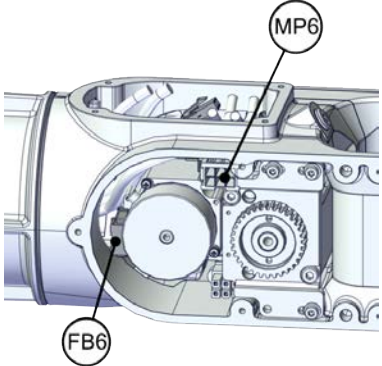

	Action	Note
1	For robots with protection type Clean Room: Clean the joints that have been opened and wipe the parts free from particles with spirit on a lint free.	

Continues on next page

5.6.2 Replacing the extender unit and wrist
Continued

	Action	Note
2	<p>Reconnect the connectors.</p> <ul style="list-style-type: none"> • FB6 • MP6 <p> Tip</p> <p>See the number markings on the connectors for help to find the corresponding connector.</p>	 <p>xx1800002994</p>
3	<p>Route and secure the cabling with cable straps.</p> <p> CAUTION</p> <p>Correct cable routing is highly important. If the cables are routed and secured incorrectly the cables can be damaged.</p>	
4	<p>Insert the cabling and connectors into the wrist.</p>	

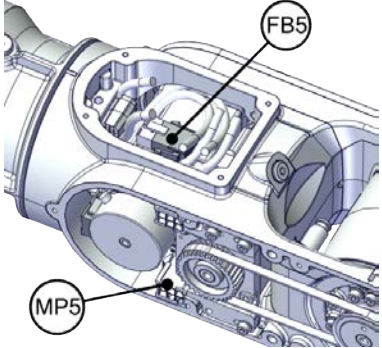
Reconnecting the axis-5 motor connectors

	Action	Note
1	<p>For robots with protection type Clean Room: Clean the joints that have been opened and wipe the parts free from particles with spirit on a lint free.</p>	
2	<p>Reconnect the connectors.</p> <ul style="list-style-type: none"> • FB5 • MP5 <p> Tip</p> <p>See the number markings on the connectors for help to find the corresponding connector.</p>	 <p>xx1800003025</p>
3	<p>Route and secure the cabling with cable straps.</p> <p> CAUTION</p> <p>Correct cable routing is highly important. If the cables are routed and secured incorrectly the cables can be damaged.</p>	
4	<p>Insert the cabling and connectors into the wrist.</p>	



Continues on next page

5 Repair

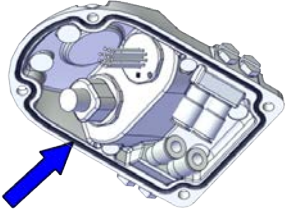

5.6.2 Replacing the extender unit and wrist

Continued

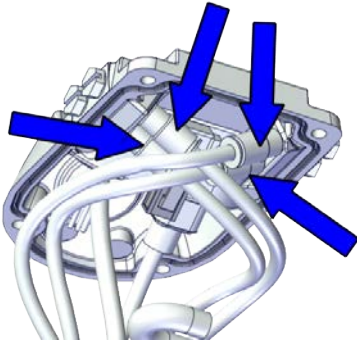
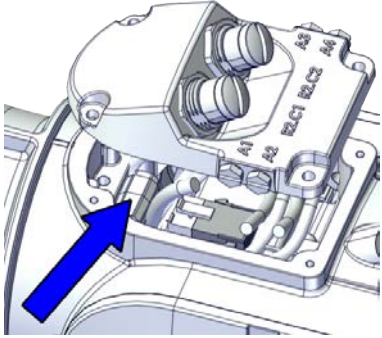
Refitting the process hub

	Action	Note
1	<p>For robots with protection type Clean Room: Clean the joints that have been opened and wipe the parts free from particles with spirit on a lint free.</p>	
2	<p>For robots with protection class IP67 (option 3350-670) For robots with protection type Clean Room (option 3351-4) Check the gasket. Replace if damaged.</p>	<p>Gasket for process hub: 3HAC065352-001</p>  <p>xx1900002187</p>
3	<p>Reconnect the air hoses in a cross pattern.</p> <p> Tip</p> <p>See the number markings on the air hoses for help to find the corresponding air hoses. The air hoses with the same number connect to the same Y-shaped connector.</p>	 <p>xx1800002945</p>
4	<p>For robots with CP/CS cabling Reconnect the connector.</p> <ul style="list-style-type: none"> • J5.C1 	 <p>xx1800002947</p>

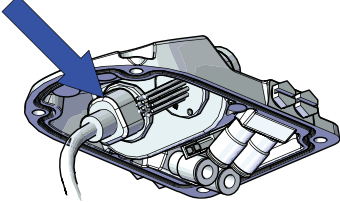
Continues on next page

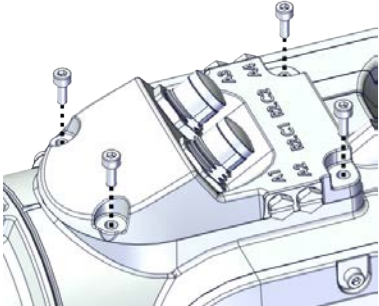
	Action	Note
5	<p>For robots with Ethernet cabling Reconnect the connector J5.C2 using the tool.</p>	<p>J5.C2 connector assembly tool, included in the special toolkit 3HAC071022-001</p>  <p>xx1800002948</p>
6	<p>Route and secure the cabling with cable straps.</p> <p> CAUTION</p> <p>Correct cable routing is highly important. If the cables are routed and secured incorrectly the cables can be damaged.</p>	
7	<p>Refit the cover.</p>	<p>Screw: M3x8 12.9 Lafre 2C2B/FC6.9 (4 pcs) Tightening torque: 1.2 Nm</p>  <p>xx1800002944</p>

Refitting the covers

	Action	Note
1	<p>For robots with protection type Clean Room: Clean the joints that have been opened and wipe the parts free from particles with spirit on a lint free.</p>	

Continues on next page



5 Repair

5.6.2 Replacing the extender unit and wrist

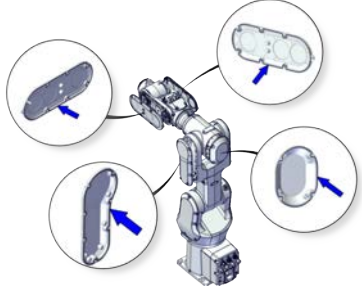
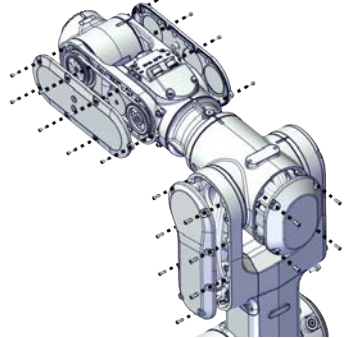
Continued

	Action	Note
2	<p>For robots with protection class IP67 (option 3350-670)</p> <p>For robots with protection type Clean Room (option 3351-4)</p> <p>Check the gaskets.</p> <p>Replace if damaged.</p>	 <p>xx1900002178</p>
3	Apply grease to the cable package, cover all moving area of the package.	
4	Apply grease to the covers that have contacting area with the cable package.	
5	<p>Refit the covers.</p> <ul style="list-style-type: none"> • Wrist covers • Lower arm support cover • Housing cover 	<p>Screw: M3x8 12.9 Lafre 2C2B/FC6.9</p> <p>Tightening torque: 1.2 Nm</p>  <p>xx1800003612</p>

Concluding procedure

	Action	Note
1	<p>For robots with protection type Clean Room:</p> <p>Clean and paint the joints that have been opened. See Cut the paint or surface on the robot before replacing parts on page 124</p> <p> Note</p> <p>After all repair work, wipe the Clean Room robot free from particles with spirit on a lint free cloth.</p>	
2	Recalibrate the robot.	Calibration is detailed in section Calibration on page 685 .
3	<p> DANGER</p> <p>Make sure all safety requirements are met when performing the first test run. See Test run after installation, maintenance, or repair on page 91.</p>	

5.7 Motors

5.7.1 Replacing the axis-1 motor

Location of the axis-1 motor

The axis-1 motor is located as shown in the figure.

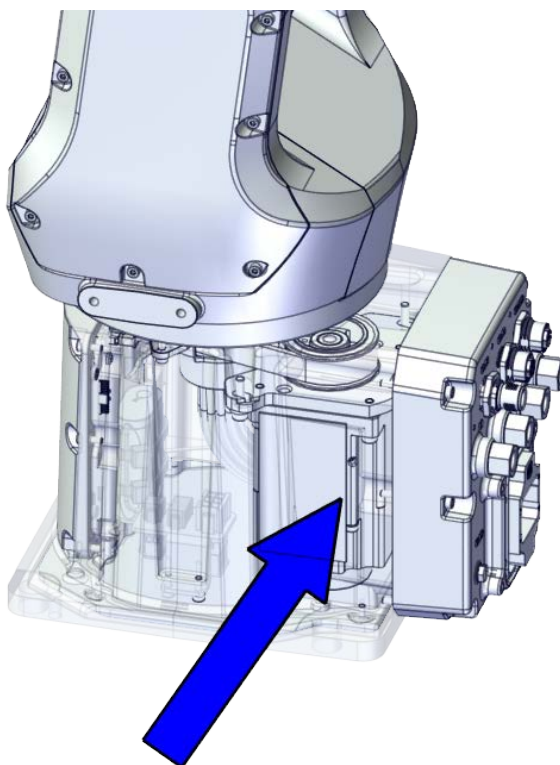

xx1800002482

Required spare parts



Note

The spare part numbers that are listed in the table can be out of date. See the latest spare parts of the IRB 1100 via myABB Business Portal, www.abb.com/myABB.

Spare part	Article number	Note
Motor with flange, axis 1	3HAC083589-001	
Timing belt, axis 2	3HAC061935-001	
Base bottom cover	3HAC060463-001	Standard configuration, used for robots with rear connector interface.
Base rear cover	3HAC070312-001	Used for robots with bottom connector interface.

Continues on next page

5 Repair

5.7.1 Replacing the axis-1 motor

Continued

Spare part	Article number	Note
Base rear cover, Clean Room	3HAC075513-001	Used for robots with bottom connector interface. Used with protection type Clean Room.
Base adapter	3HAC070313-001	Used for robots with bottom connector interface.
Base adapter, Clean Room	3HAC075793-001	Used for robots with bottom connector interface. Used with protection type Clean Room.
Gasket for base bottom	3HAC065345-001	Used with protection class IP67 and protection type Clean Room. Replace if damaged.
Gasket for base rear	3HAC065350-001	Used with protection class IP67 and protection type Clean Room. Replace if damaged.
Cooling pad for axis-1 and -2 motors	3HAC071020-001	Cooling pads are wear parts. One cooling pad sheet contains 6 pieces of small pad. Replace if damaged with one piece each time.
Washer	3HAC063985-001	9x4.3x1, Steel

Required tools and equipment

Equipment	Article number	Note
Standard toolkit	-	Content is defined in section Standard toolkit on page 733 .
Calibration tool box, Axis Calibration	3HAC074119-001	Delivered as a set of calibration tools. Required if Axis Calibration is the valid calibration method for the robot. The tool box also includes a unique calibration pin for IRB 1100 to be fitted to the tool flange during calibration of axis 6.
24 VDC power supply	-	Used to release the motor brakes.
Dynamometer	-	Used for measuring the timing belt tension.

Required consumables

Consumable	Article number	Note
Cable straps	-	
Grease	3HAC029132-001	FM 222

Continues on next page

Deciding calibration routine

Decide which calibration routine to be used, based on the information in the table. Depending on which routine is chosen, action might be required prior to beginning the repair work of the robot, see the table.

	Action	Note
1	<p>Decide which calibration routine to use for calibrating the robot.</p> <ul style="list-style-type: none"> Reference calibration. External cable packages (DressPack) and tools can stay fitted on the robot. Fine calibration. All external cable packages (DressPack) and tools must be removed from the robot. 	<p> Note</p> <p>Calibrating axis 6 always requires tools to be removed from the mounting flange (also for reference calibration) since the mounting flange is used for installation of the calibration tool.</p>
	<p>If the robot is to be calibrated with reference calibration:</p> <p>Find previous reference values for the axis or create new reference values. These values are to be used after the repair procedure is completed, for calibration of the robot.</p> <p>If no previous reference values exist, and no new reference values can be created, then reference calibration is not possible.</p>	<p>Follow the instructions given in the reference calibration routine on the FlexPendant to create reference values.</p> <p>Creating new values requires possibility to move the robot.</p> <p>Read more about reference calibration for Axis Calibration in Reference calibration routine on page 696.</p>
	<p>If the robot is to be calibrated with fine calibration:</p> <p>Remove all external cable packages (DressPack) and tools from the robot.</p>	

Removing the motor

Use these procedures to remove the axis-1 motor.

Preparations before removing the axis-1 motor

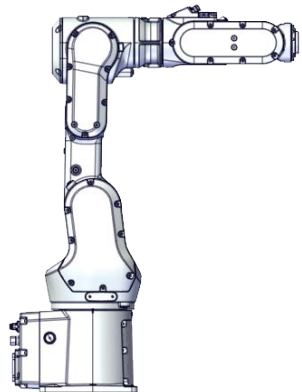

	Action	Note
1	Decide which calibration routine to use, and take actions accordingly prior to beginning the repair procedure.	
2	Jog all axes to zero position.	 <p>xx1800003288</p>

Continues on next page





5 Repair

5.7.1 Replacing the axis-1 motor

Continued

	Action	Note
3	 DANGER Turn off all: <ul style="list-style-type: none"> • electric power supply • hydraulic pressure supply • air pressure supply to the robot, before entering the safeguarded space.	
4	 CAUTION For robots with protection type Clean Room Always cut the paint with a knife and grind the paint edge when disassembling parts of the robot! See Cut the paint or surface on the robot before replacing parts on page 124 .	



Putting the robot on its side

	Action	Note
1	 DANGER Make sure that all supplies for electrical power, hydraulic pressure, and air pressure are turned off.	
2	 CAUTION For robots with protection type Clean Room Always cut the paint with a knife and grind the paint edge when disassembling parts of the robot! See Cut the paint or surface on the robot before replacing parts on page 124 .	
3	 CAUTION The IRB 1100 robot weighs 21.1 kg and can be lifted by one person.	
4	 WARNING The robot is likely to be mechanically unstable if not secured to the foundation.	

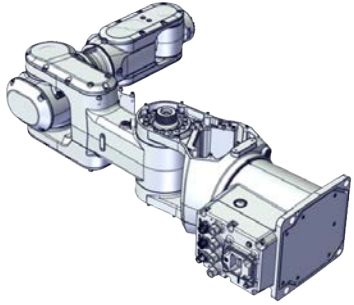
Continues on next page

	Action	Note
5	Loosen the robot from the foundation by removing the foundation attachment screws and put the robot on its side.	 <p>xx1800003033</p>

Opening the connector interface plate

	Action	Note
1	 <p>DANGER</p> <p>Make sure that all supplies for electrical power, hydraulic pressure, and air pressure are turned off.</p>	
2	 <p>CAUTION</p> <p>For robots with protection type Clean Room Always cut the paint with a knife and grind the paint edge when disassembling parts of the robot! See Cut the paint or surface on the robot before replacing parts on page 124.</p>	

5 Repair

5.7.1 Replacing the axis-1 motor

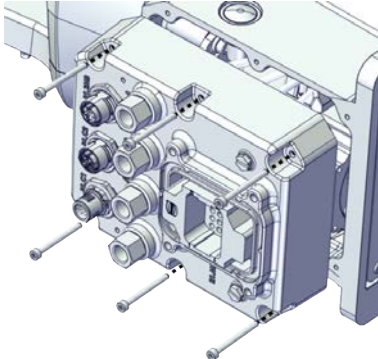
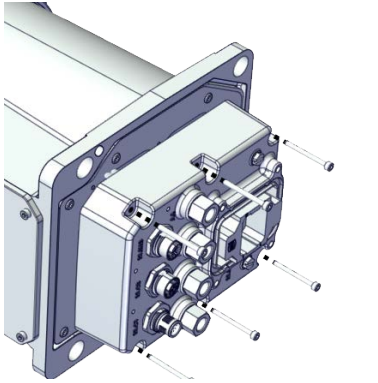
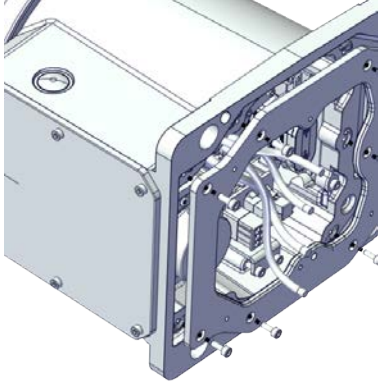

Continued

	Action	Note
3	<p>Remove the connector interface plate attachment screws and carefully open the plate.</p> <p> CAUTION</p> <p>There are cabling attached to the cover. The cover cannot be removed completely until the connectors are removed.</p>	<p>Valid for cabling with rear interface</p>  <p>xx1800003034</p> <p>Valid for cabling with bottom interface (option 3309-1)</p>  <p>xx1800003055</p>
4	<p>Valid for cabling with bottom interface (option 3309-1)</p> <p>Remove the base adapter.</p>	 <p>xx1800003056</p>

Continues on next page

Removing base covers

Notice that the procedure differs depending on if the connector interface is located either at the rear or at the bottom of the base.

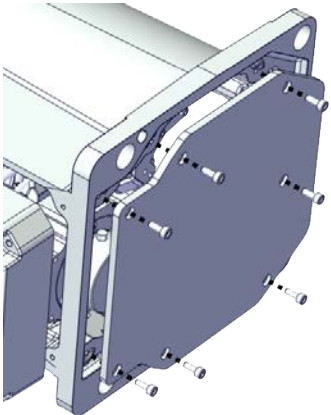
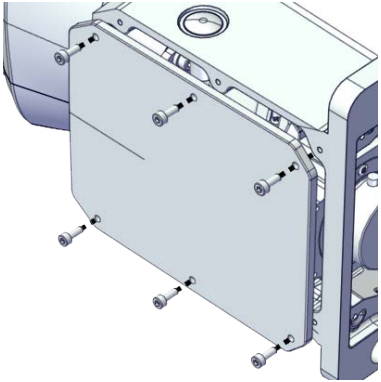
	Action	Note
1	 <p>DANGER</p> <p>Make sure that all supplies for electrical power, hydraulic pressure, and air pressure are turned off.</p>	
2	 <p>CAUTION</p> <p>For robots with protection type Clean Room Always cut the paint with a knife and grind the paint edge when disassembling parts of the robot! See Cut the paint or surface on the robot before replacing parts on page 124.</p>	
3	<p>Valid for cabling with rear interface Remove the base bottom cover.</p>	 <p>xx1800003035</p>
4	<p>Valid for cabling with bottom interface (option 3309-1) Remove the base rear cover.</p>	 <p>xx1800003057</p>



Continues on next page

5 Repair

5.7.1 Replacing the axis-1 motor

Continued

Disconnecting axis-1 motor connectors

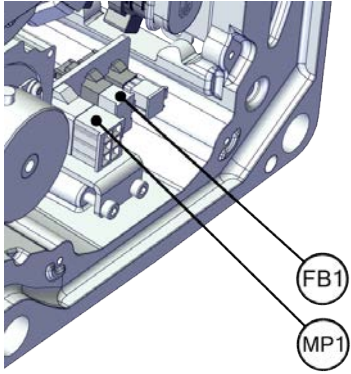
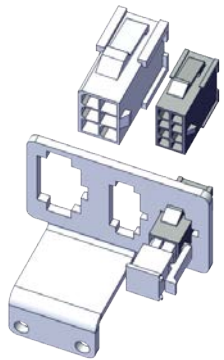
	Action	Note
1	 DANGER Make sure that all supplies for electrical power, hydraulic pressure, and air pressure are turned off.	
2	 CAUTION For robots with protection type Clean Room Always cut the paint with a knife and grind the paint edge when disassembling parts of the robot! See Cut the paint or surface on the robot before replacing parts on page 124 .	
3	Disconnect the connectors. <ul style="list-style-type: none"> • FB1 • MP1  Tip Take photos of the connector and cable position before disconnecting them, to have as a reference when reconnecting.	 xx1800003613
4	Snap loose and remove the female head of the connectors from the connector plate.	 xx1800003314



Separating the cable package from the base

	Action	Note
1	 DANGER Make sure that all supplies for electrical power, hydraulic pressure, and air pressure are turned off.	

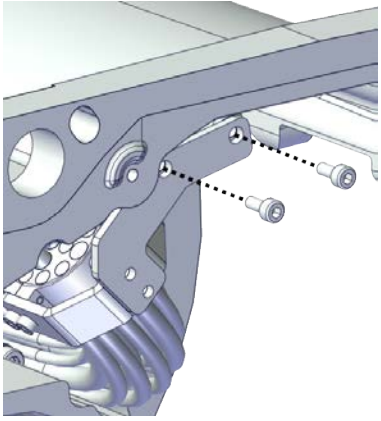
Continues on next page

	Action	Note
2	<p> CAUTION</p> <p>For robots with protection type Clean Room Always cut the paint with a knife and grind the paint edge when disassembling parts of the robot! See <i>Cut the paint or surface on the robot before replacing parts on page 124.</i></p>	
3	Remove the cable bracket.	 <p>xx1800003042</p>

Removing the axis-1 motor



	Action	Note
1	<p> DANGER</p> <p>Make sure that all supplies for electrical power, hydraulic pressure, and air pressure are turned off.</p>	
2	<p> CAUTION</p> <p>For robots with protection type Clean Room Always cut the paint with a knife and grind the paint edge when disassembling parts of the robot! See <i>Cut the paint or surface on the robot before replacing parts on page 124.</i></p>	
3	<p> CAUTION</p> <p>Removing motors will release axes. This means the axes can fall down. Make sure axes are well supported before removing motors.</p>	

Continues on next page

5 Repair

5.7.1 Replacing the axis-1 motor

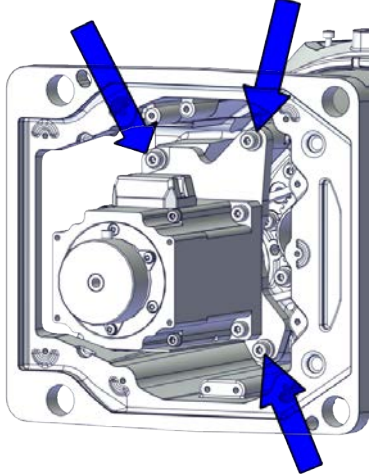
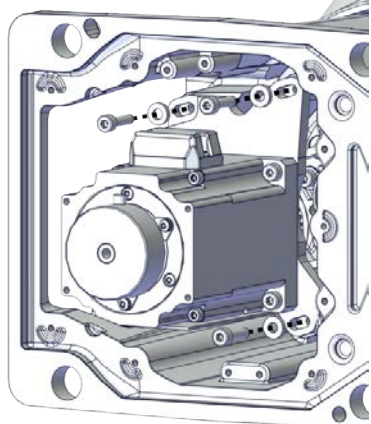
Continued

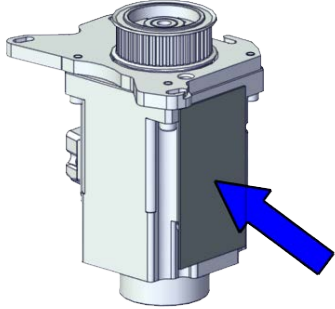
	Action	Note
4	Loosen the screws and move the motor slightly to slacken the timing belt.	 <p>xx1800003064</p>
5	Remove the screws and washers.	 <p>xx1800003065</p>
6	Carefully lift out the motor.  CAUTION A cooling pad is attached to the motor, which may stick to the casting. Always use a plastic sheet with caution to remove the pad from the casting. Pay attention not to scratch the casting or damage the pad.	Cooling pad location  <p>xx1800003602</p>

Continues on next page

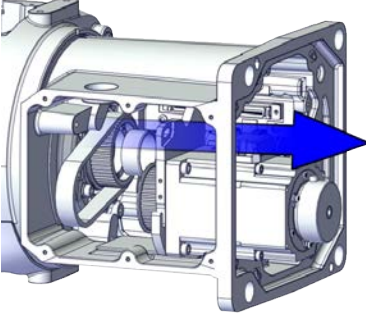
	Action	Note
7	Remove the timing belt from its groove on the motor.	 <p>xx1800003614</p>

Refitting the motor

Use these procedures to refit the axis-1 motor.

Refitting the axis-1 motor

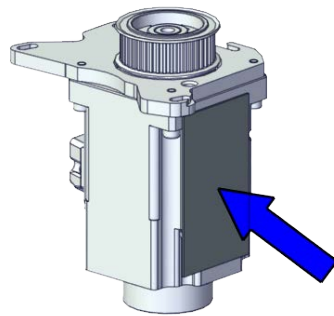

	Action	Note
1	For robots with protection type Clean Room: Clean the joints that have been opened and wipe the parts free from particles with spirit on a lint free.	
2	Check that: <ul style="list-style-type: none"> • all assembly surfaces are clean and without damages • the motor is clean and undamaged. 	
3	Check the cooling pad. Replace if damaged.	<p>Cooling pad for axis-1 and -2 motors: 3HAC071020-001</p>  <p>xx1800003602</p>

Continues on next page

5 Repair

5.7.1 Replacing the axis-1 motor

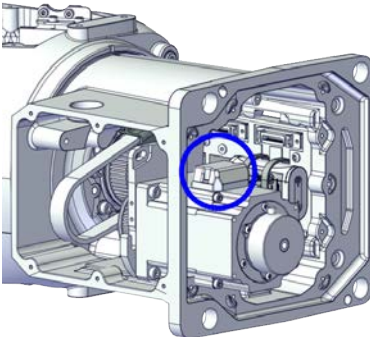
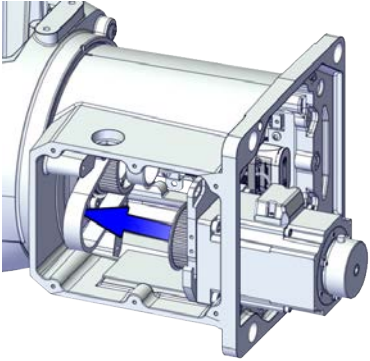

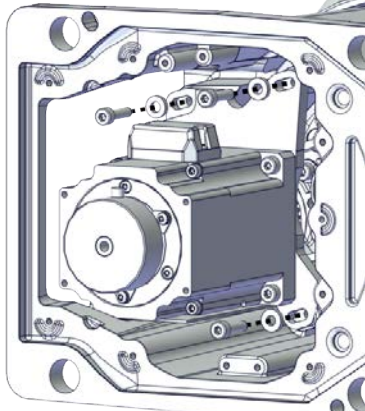
Continued

	Action	Note
4	Orient the motor correctly and fit it into the base.	<p>Motor orientation: orient the motor according to the figure below, in regard to the encircled motor connector.</p>  <p>xx1800003616</p>
5	Install the timing belt to the motor pulley.	 <p>xx1800003615</p>
6	<p>Refit the screws and washers.</p> <p> Note</p> <p>Do not tighten the screws yet.</p>	<p>Screw: M4x16 12.9 Lafre 2C2B/FC6.9 (3 pcs) Washer, 3HAC063985-001 (3 pcs)</p>  <p>xx1800003065</p>

Continues on next page

5.7.1 Replacing the axis-1 motor
Continued

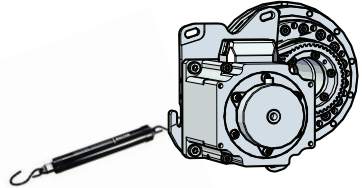
Adjusting the axis-1 timing belt tension

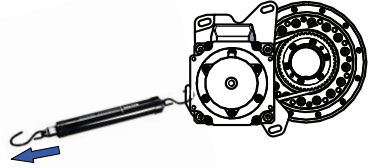
	Action	Note
1	For robots with protection type Clean Room: Clean the joints that have been opened and wipe the parts free from particles with spirit on a lint free.	
2	Use a handheld dynamometer hooking to the motor.	 xx1900000040
3	Pull the dynamometer to make the tension falling in the allowed force range.  Note During the measurement, make sure that all interferences that may affect the force are removed. Pay attention to the force application direction.	Used belt: 58.24-63.56 N New belt: 83.2-90.8 N (for reference only)  xx1900000041
4	Secure the motor with the screws.	Tightening torque: 3 Nm

Securing the lower cable package to the base

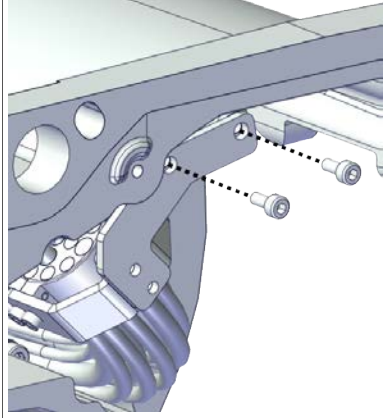
	Action	Note
1	For robots with protection type Clean Room: Clean the joints that have been opened and wipe the parts free from particles with spirit on a lint free.	
2	Refit the cable bracket.	Screw: M2.5x6 12.9 Lafre 2C2B/FC6.9 (2 pcs) Tightening torque: 0.6 Nm  xx1800003042



Continues on next page

5 Repair

5.7.1 Replacing the axis-1 motor

Continued

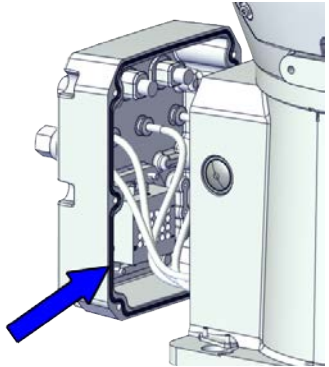
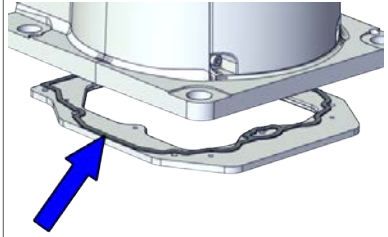
Refitting the connector interface plate

	Action	Note
1	For robots with protection type Clean Room: Clean the joints that have been opened and wipe the parts free from particles with spirit on a lint free.	
2	For robots with protection class IP67 (option 3350-670) For robots with protection type Clean Room (option 3351-4) Check the gasket. Replace if damaged.	<p>Valid for cabling with rear interface Gasket for base rear: 3HAC065350-001</p>  <p>xx1900002183</p> <p>Valid for cabling with bottom interface (option 3309-1) Gasket for base bottom: 3HAC065345-001</p>  <p>xx1900002188</p>
3	Route and secure the cabling with cable straps.  CAUTION Correct cable routing is highly important. If the cables are routed and secured incorrectly the cables can be damaged.	

Continues on next page

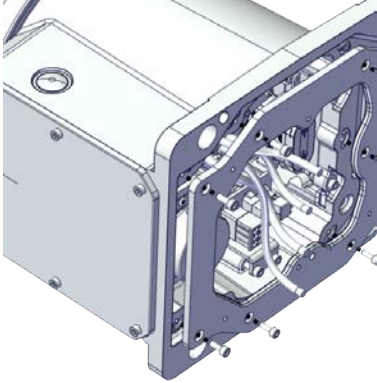
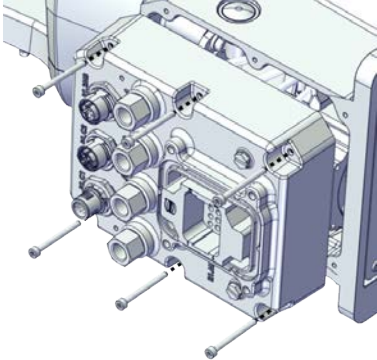
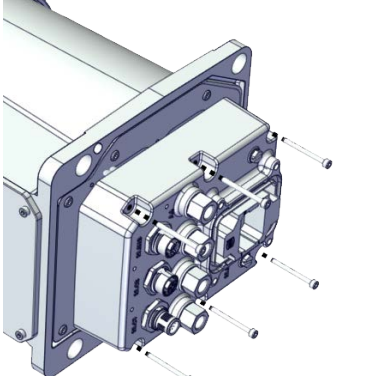
	Action	Note
4	<p>Valid for cabling with bottom interface (option 3309-1) Refit the base adapter.</p>	<p>Screw: M3x8 Steel 8.8-A2F (7 pcs) Tightening torque: 1.2 Nm</p>  <p>xx1800003056</p>
5	<p>Refit the connector interface plate to the base.</p>	<p>Screw: M3x30 12.9 Lafre 2C2B/FC6.9 (6 pcs) Tightening torque: 1.2 Nm Valid for cabling with rear interface</p>  <p>xx1800003034</p> <p>Valid for cabling with bottom interface (option 3309-1)</p>  <p>xx1800003055</p>

Continues on next page



5 Repair

5.7.1 Replacing the axis-1 motor

Continued

Refitting the base cover

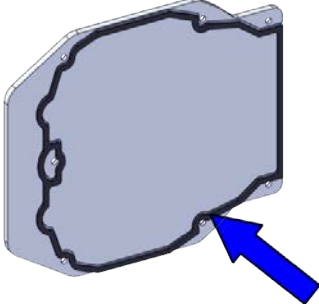
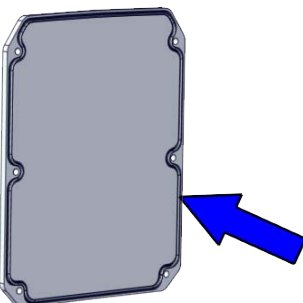
Notice that the procedure differs depending on if the connector interface is located either at the rear or at the bottom of the base.

	Action	Note
1	For robots with protection type Clean Room: Clean the joints that have been opened and wipe the parts free from particles with spirit on a lint free.	
2	For robots with protection class IP67 (option 3350-670) For robots with protection type Clean Room (option 3351-4) Check the gasket. Replace if damaged.	<p>Valid for cabling with rear interface Gasket for base bottom: 3HAC065345-001</p>  <p>xx1900002184</p> <p>Valid for cabling with bottom interface (option 3309-1) Gasket for base rear: 3HAC065350-001</p>  <p>xx1900002189</p>
3	Apply grease to the cable package, cover all moving area of the package.	
4	Apply grease to the covers that have contacting area with the cable package.	
5	Route and secure the cabling with cable straps.  CAUTION Correct cable routing is highly important. If the cables are routed and secured incorrectly the cables can be damaged.	

Continues on next page

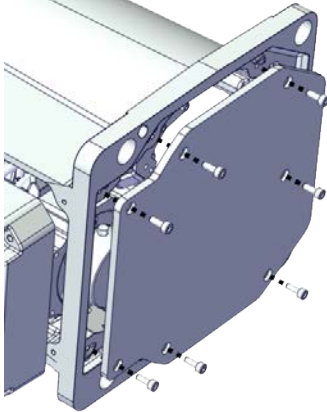
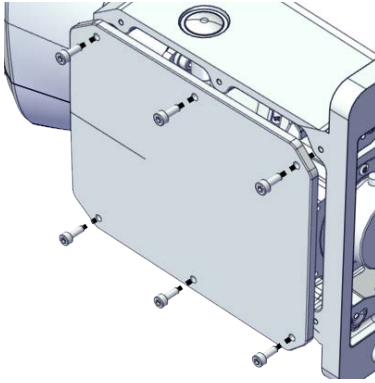
	Action	Note
6	Valid for cabling with rear interface Refit the bottom cover.	Screw: M3x8 Steel 8.8-A2F (7 pcs) Tightening torque: 1.2 Nm  xx1800003035
7	Refit the rear cover.	Screw: M3x8 12.9 Lafre 2C2B/FC6.9 (6 pcs) Tightening torque: 1.2 Nm  xx1800003057

Securing the robot to the foundation

	Action	Note
1	For robots with protection type Clean Room: Clean the joints that have been opened and wipe the parts free from particles with spirit on a lint free.	
2	 CAUTION The IRB 1100 robot weighs 21.1 kg and can be lifted by one person.	
3	Raise the robot to standing and secure to the foundation with the attachment screws and washers.	Attachment screws: M12x25 (robot installation directly on foundation), quality: 8.8. Washers: 24 x 13 x 2.5, steel hardness class 200HV. Tightening Torque: 50 Nm±5 Nm.



Continues on next page

5 Repair

5.7.1 Replacing the axis-1 motor

Continued

Concluding procedure

	Action	Note
1	<p>For robots with protection type Clean Room: Clean and paint the joints that have been opened. See Cut the paint or surface on the robot before replacing parts on page 124</p> <p> Note</p> <p>After all repair work, wipe the Clean Room robot free from particles with spirit on a lint free cloth.</p>	
2	<p>Recalibrate the robot.</p>	<p>Calibration is detailed in section Calibration on page 685.</p>
3	<p> DANGER</p> <p>Make sure all safety requirements are met when performing the first test run. See Test run after installation, maintenance, or repair on page 91.</p>	

5.7.2 Replacing the axis-2 motor

Location of the axis-2 motor

The axis-2 motor is located as shown in the figure.

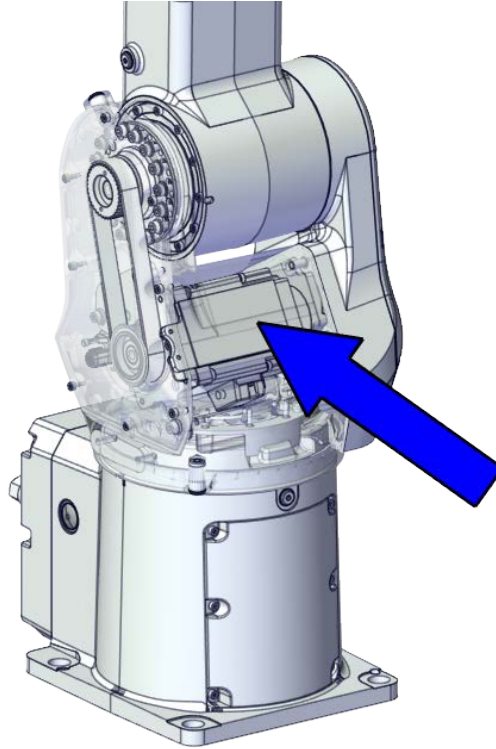

xx1800002483

Required spare parts



Note

The spare part numbers that are listed in the table can be out of date. See the latest spare parts of the IRB 1100 via myABB Business Portal, www.abb.com/myABB.

Spare part	Article number	Note
Motor with flange, axis 2	3HAC083588-001	.
Timing belt, axis 2	3HAC061935-001	
Swing cover	3HAC069051-001	
Swing cover, Clean Room	3HAC075498-001	Used with protection type Clean Room.
Swing support cover	3HAC069052-001	
Swing support cover, Clean Room	3HAC075500-001	Used with protection type Clean Room.

Continues on next page

5 Repair

5.7.2 Replacing the axis-2 motor

Continued

Spare part	Article number	Note
Gasket for swing cover	3HAC061959-003	Used with protection class IP67 and protection type Clean Room. Replace if damaged.
Gasket for swing support cover	3HAC065317-001	Used with protection class IP67 and protection type Clean Room. Replace if damaged.
Cooling pad for axis-1 and -2 motors	3HAC071020-001	Cooling pads are wear parts. One cooling pad sheet contains 6 pieces of small pad. Replace if damaged with one piece each time.
Washer	3HAC063985-001	9x4.3x1, Steel

Required tools and equipment

Equipment	Article number	Note
Standard toolkit	-	Content is defined in section Standard toolkit on page 733 .
Calibration tool box, Axis Calibration	3HAC074119-001	Delivered as a set of calibration tools. Required if Axis Calibration is the valid calibration method for the robot. The tool box also includes a unique calibration pin for IRB 1100 to be fitted to the tool flange during calibration of axis 6.
24 VDC power supply	-	Used to release the motor brakes.
Sonic tension meter	-	Used for measuring the timing belt tension.
Dynamometer	-	Used for measuring the timing belt tension.

Required consumables

Consumable	Article number	Note
Cable straps	-	
Grease	3HAC029132-001	FM 222
Sealing compound	3HAC026759-002	Sikaflex 521 FC For robots with protection type Clean Room.

Continues on next page

Deciding calibration routine

Decide which calibration routine to be used, based on the information in the table. Depending on which routine is chosen, action might be required prior to beginning the repair work of the robot, see the table.

	Action	Note
1	<p>Decide which calibration routine to use for calibrating the robot.</p> <ul style="list-style-type: none"> Reference calibration. External cable packages (DressPack) and tools can stay fitted on the robot. Fine calibration. All external cable packages (DressPack) and tools must be removed from the robot. 	<p> Note</p> <p>Calibrating axis 6 always requires tools to be removed from the mounting flange (also for reference calibration) since the mounting flange is used for installation of the calibration tool.</p>
	<p>If the robot is to be calibrated with reference calibration:</p> <p>Find previous reference values for the axis or create new reference values. These values are to be used after the repair procedure is completed, for calibration of the robot.</p> <p>If no previous reference values exist, and no new reference values can be created, then reference calibration is not possible.</p>	<p>Follow the instructions given in the reference calibration routine on the FlexPendant to create reference values.</p> <p>Creating new values requires possibility to move the robot.</p> <p>Read more about reference calibration for Axis Calibration in Reference calibration routine on page 696.</p>
	<p>If the robot is to be calibrated with fine calibration:</p> <p>Remove all external cable packages (DressPack) and tools from the robot.</p>	

Removing the motor

Use these procedures to remove the axis-2 motor.

Preparations before removing the axis-2 motor

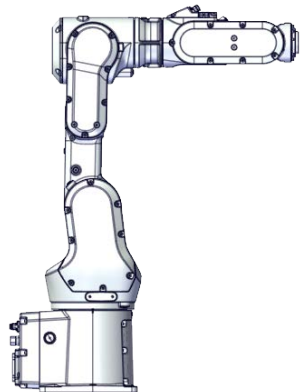

	Action	Note
1	Decide which calibration routine to use, and take actions accordingly prior to beginning the repair procedure.	
2	Jog all axes to zero position.	 <p>xx1800003288</p>

Continues on next page



5 Repair

5.7.2 Replacing the axis-2 motor





Continued

	Action	Note
3	 DANGER Turn off all: <ul style="list-style-type: none"> • electric power supply • hydraulic pressure supply • air pressure supply to the robot, before entering the safeguarded space.	
4	 CAUTION For robots with protection type Clean Room Always cut the paint with a knife and grind the paint edge when disassembling parts of the robot! See Cut the paint or surface on the robot before replacing parts on page 124.	

Removing the axis-2 motor

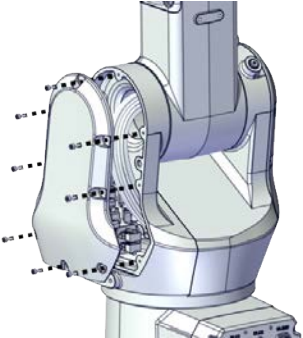
	Action	Note
1	 DANGER Make sure that all supplies for electrical power, hydraulic pressure, and air pressure are turned off.	
2	 CAUTION For robots with protection type Clean Room Always cut the paint with a knife and grind the paint edge when disassembling parts of the robot! See Cut the paint or surface on the robot before replacing parts on page 124.	
3	 CAUTION Removing motors will release axes. This means the axes can fall down. Make sure axes are well supported before removing motors.	

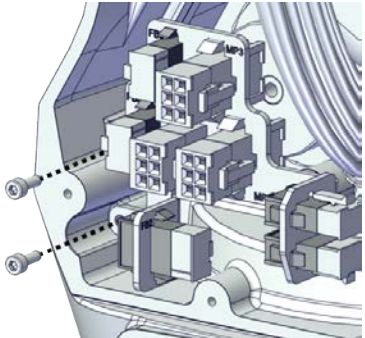
Continues on next page

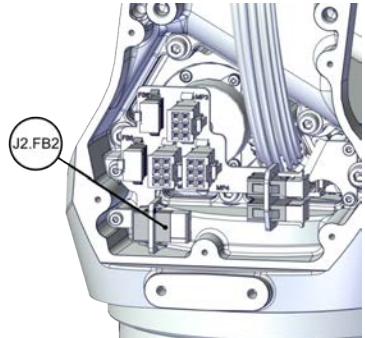
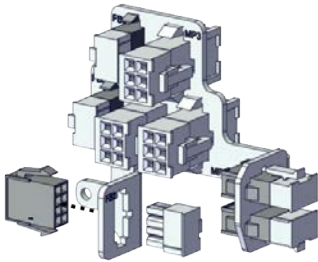

	Action	Note
4	Remove the swing support cover.	 <p>xx1800002488</p>
5	Remove the connector plate.  CAUTION Be aware of the cablings that are attached to the connector plate! The connector plate cannot be removed completely until the connectors are removed from the plate.	 <p>xx1800002489</p>
6	Disconnect the connector. <ul style="list-style-type: none"> • J2.FB2  Tip Take photos of the connector and cable position before disconnecting them, to have as a reference when reconnecting.	 <p>xx1800002490</p>
7	Snap loose and remove the female head of the connector from the connector plate.	 <p>xx1800002491</p>

Continues on next page

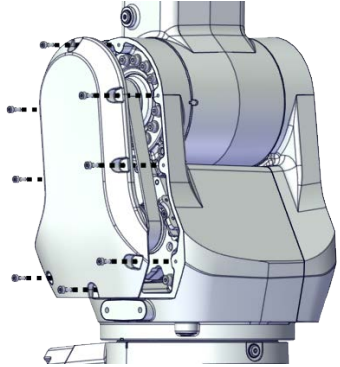

5 Repair

5.7.2 Replacing the axis-2 motor

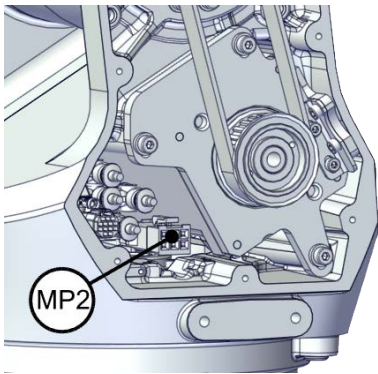
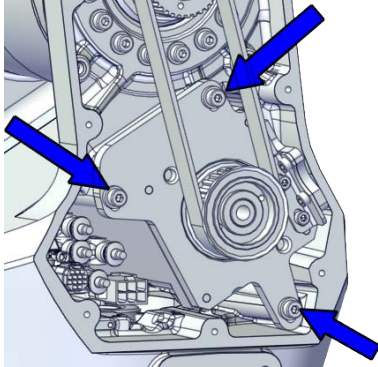
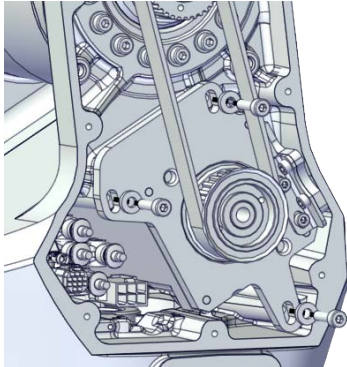

Continued

	Action	Note
8	Remove the swing cover.	 <p>xx1800002492</p>
9	Disconnect the connector. <ul style="list-style-type: none">• MP2  Tip Take photos of the connector and cable position before disconnecting them, to have as a reference when reconnecting.	 <p>xx1800002495</p>
10	Loosen the screws and move the motor slightly to slacken the timing belt.	 <p>xx1800002493</p>
11	Remove the screws and washers.	 <p>xx1800002494</p>

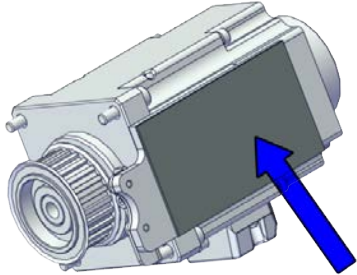
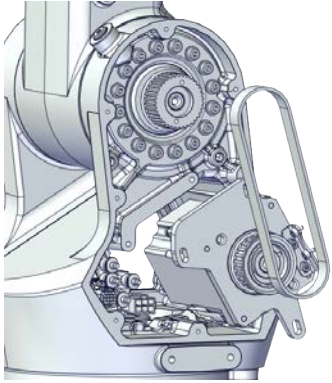
Continues on next page

	Action	Note
12	<p>Carefully lift out the motor.</p> <p> CAUTION</p> <p>A cooling pad is attached to the motor, which may stick to the casting. Always use a plastic sheet with caution to remove the pad from the casting. Pay attention not to scratch the casting or damage the pad.</p> <p> CAUTION</p> <p>Be aware of the motor cabling. The motor cannot be removed completely until the connector is disconnected, as shown in following step.</p>	<p>Cooling pad location</p>  <p>xx1800003603</p>
13	<p>Remove the timing belt from its groove on the motor.</p>	 <p>xx1800002496</p>

Removing the cooling pad

	Action	Note
1	<p> DANGER</p> <p>Make sure that all supplies for electrical power, hydraulic pressure, and air pressure are turned off.</p>	
2	<p> CAUTION</p> <p>For robots with protection type Clean Room</p> <p>Always cut the paint with a knife and grind the paint edge when disassembling parts of the robot! See Cut the paint or surface on the robot before replacing parts on page 124.</p>	

Continues on next page

5 Repair

5.7.2 Replacing the axis-2 motor

Continued

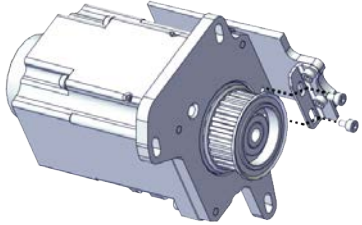
	Action	Note
3	Loosen the cooling pad bracket screws on the motor flange.	 xx1800003026
4	Use a plastic sheet with caution to remove the cooling pad together with the bracket from the motor. Pay attention not to scratch the motor or damage the pad.	

Refitting the motor

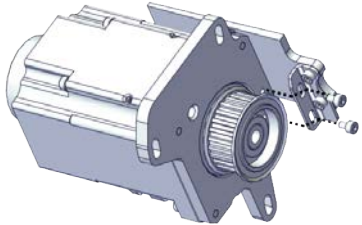

Use these procedures to refit the axis-2 motor.

Refitting the cooling pad

	Action	Note
1	For robots with protection type Clean Room: Clean the joints that have been opened and wipe the parts free from particles with spirit on a lint free.	
2	Attach the cooling pad together with the bracket to the motor. Make sure the bracket does not exceed the motor flange and the screw holes are aligned.	Cooling pad for axis-1 and -2 motors: 3HAC071020-001
3	Refit the cooling pad bracket.	Screw: M3x5 12.9 Lafre 2C2B/FC6.9 (2 pcs) Tightening torque: 1.2 Nm  xx1800003026

Continues on next page

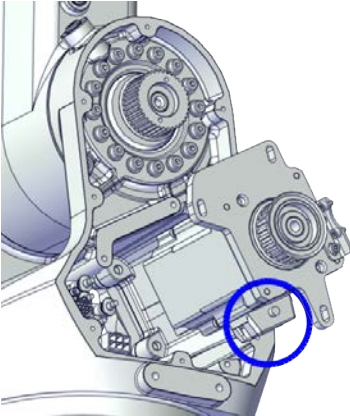
Refitting the axis-2 motor

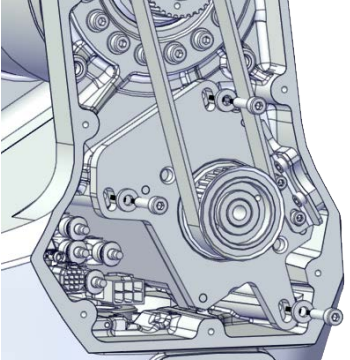

	Action	Note
1	<p>For robots with protection type Clean Room: Clean the joints that have been opened and wipe the parts free from particles with spirit on a lint free.</p>	
2	<p>Check that:</p> <ul style="list-style-type: none"> • all assembly surfaces are clean and without damages • the motor is clean and undamaged. 	
3	<p>Orient the motor correctly and fit it into the swing.</p> <p> Tip</p> <p>Bend the motor signal cable back towards the swing support.</p>	<p>Motor orientation: orient the motor according to the figure below, in regard to the encircled motor connector.</p>  <p>xx1800003027</p>
4	<p>Refit the screws and washers.</p> <p> Note</p> <p>Do not tighten the screws yet.</p>	<p>Screw: M4x16 12.9 Lafre 2C2B/FC6.9 (3 pcs) Washer, 3HAC063985-001 (3 pcs)</p>  <p>xx1800002494</p>

Continues on next page

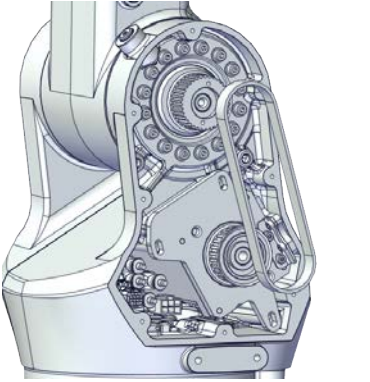

5 Repair

5.7.2 Replacing the axis-2 motor

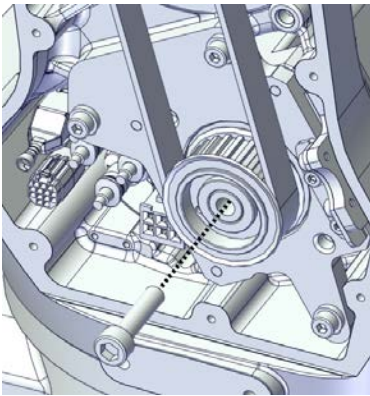
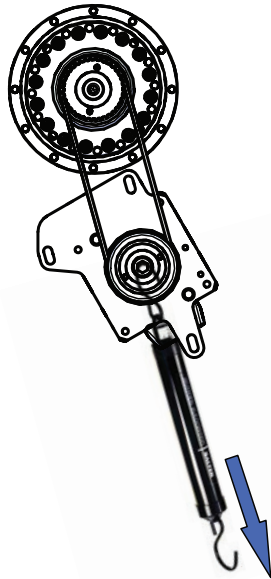
Continued

	Action	Note
5	Install the timing belt to the pulleys and verify that the belt runs correctly in the grooves of the pulleys.	 <p>xx1800003028</p>
6	Install an M6x25 or longer adjustment screw to the motor.  Note Do not insert the entire screw to the hole.	 <p>xx1900000010</p>
7	Use a handheld dynamometer hooking to the screw and pull the dynamometer to reach the initial referenced force.	<p>Initial referenced force for used belt: 68.18-75.04 N (for reference only) Initial referenced force for new belt: 97.4-107.2 N</p>  <p>xx1900000029</p>

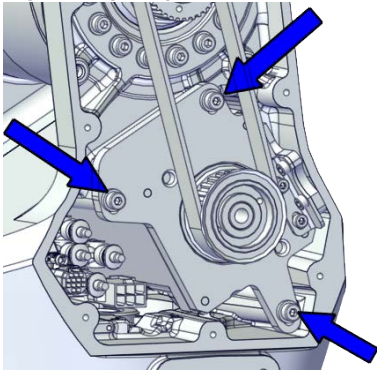
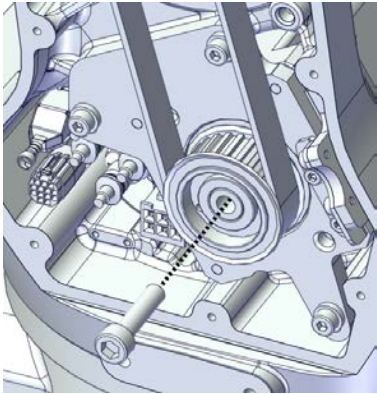
Continues on next page

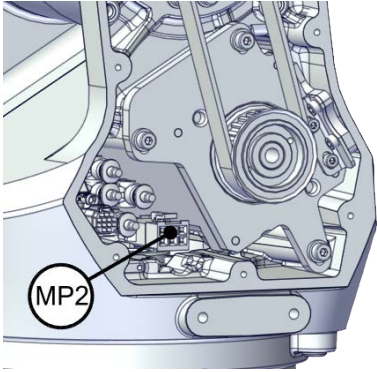
	Action	Note
8	Secure the motor with the screws.	<p>Tightening torque: 3.5 Nm</p>  <p>xx1800002493</p>
9	Use a sonic tension meter to measure the timing belt tension.	<p>Used belt: 163-174 Hz New belt: 180-229 Hz (for reference only)</p>
10	If the timing belt tension does not meet the requirement, loosen the motor screws and readjust.	
11	Remove the adjustment screw from the motor.	 <p>xx1900000010</p>
12	<p>Reconnect the connector.</p> <ul style="list-style-type: none"> • MP2 <p> Tip</p> <p>See the number markings on the connectors for help to find the corresponding connector.</p>	 <p>xx1800002495</p>





Continues on next page

5 Repair

5.7.2 Replacing the axis-2 motor

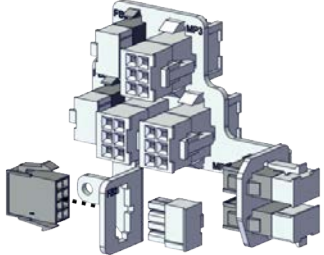
Continued

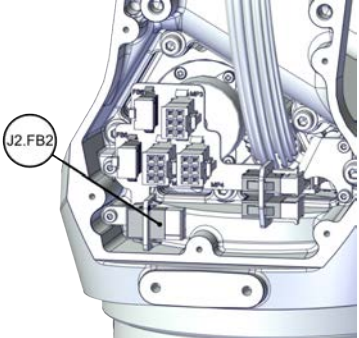
Reconnecting the connector J2.FB2

	Action	Note
1	For robots with protection type Clean Room: Clean the joints that have been opened and wipe the parts free from particles with spirit on a lint free.	
2	Insert the female header of the J2.FB2 connector to the connector plate.	 <p>xx1800002491</p>
3	Reconnect the connector. <ul style="list-style-type: none"> J2.FB2  Tip See the number markings on the connectors for help to find the corresponding connector.	 <p>xx1800002490</p>
4	Apply grease to the cable package, cover all moving area of the package.	
5	Route and secure the cabling with cable straps.  CAUTION Correct cable routing is highly important. If the cables are routed and secured incorrectly the cables can be damaged.	

Continues on next page

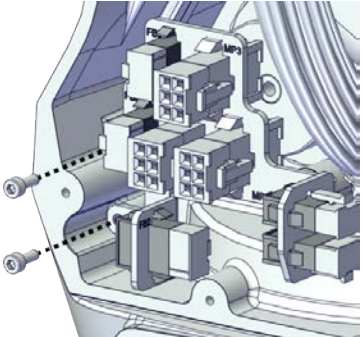
	Action	Note
6	Refit the connector plate.	<p>Screw: M3x8 12.9 Lafre 2C2B/FC6.9 (2 pcs) Tightening torque: 0.8 Nm</p>  <p>xx1800002489</p>

Refitting the swing covers

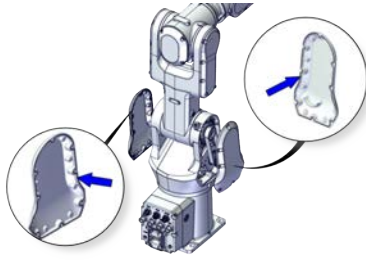
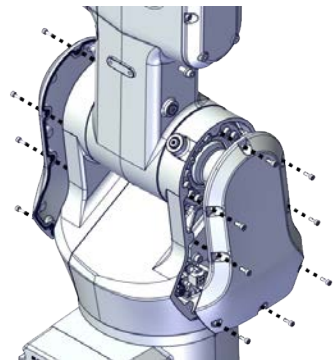
	Action	Note
1	For robots with protection type Clean Room: Clean the joints that have been opened and wipe the parts free from particles with spirit on a lint free.	
2	<p>For robots with protection class IP67 (option 3350-670) For robots with protection type Clean Room (option 3351-4) Check the gaskets. Replace if damaged.</p>	 <p>xx1900002175</p>
3	Apply grease to the cable package, cover all moving area of the package.	
4	Apply grease to the covers that have contacting area with the cable package.	
5	<p>Refit the covers.</p> <ul style="list-style-type: none"> • Swing cover • Swing support cover 	<p>Screw: M3x8 12.9 Lafre 2C2B/FC6.9 Tightening torque: 1.2 Nm</p>  <p>xx1800003607</p>



Continues on next page

5 Repair

5.7.2 Replacing the axis-2 motor

Continued

Concluding procedure

	Action	Note
1	<p>For robots with protection type Clean Room: Clean and paint the joints that have been opened. See Cut the paint or surface on the robot before replacing parts on page 124</p> <p> Note</p> <p>After all repair work, wipe the Clean Room robot free from particles with spirit on a lint free cloth.</p>	
2	Recalibrate the robot.	Calibration is detailed in section Calibration on page 685 .
3	<p> DANGER</p> <p>Make sure all safety requirements are met when performing the first test run. See Test run after installation, maintenance, or repair on page 91.</p>	

5.7.3 Replacing the axis-3 motor

Location of the axis-3 motor

The axis-3 motor is located as shown in the figure.

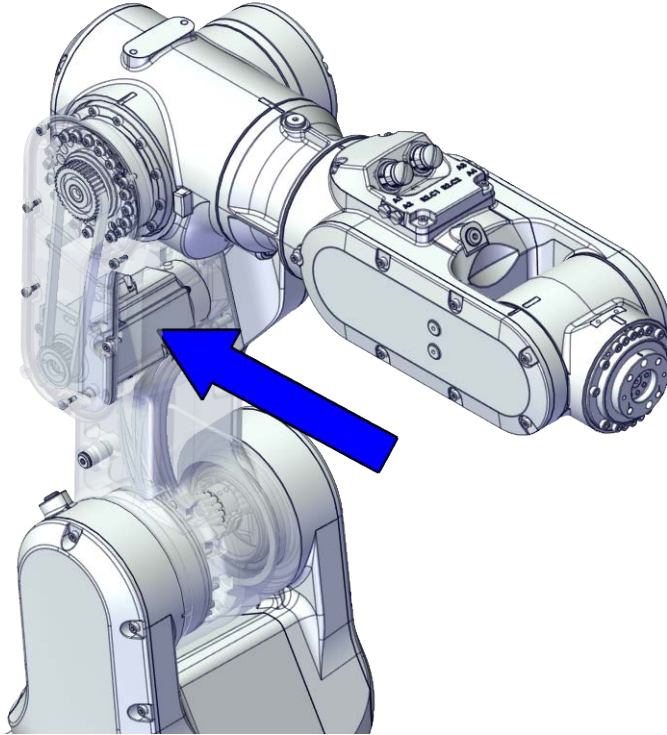

xx1800002484

Required spare parts



Note

The spare part numbers that are listed in the table can be out of date. See the latest spare parts of the IRB 1100 via myABB Business Portal, www.abb.com/myABB.

Spare part	Article number	Note
Motor with flange, axis 3	3HAC083587-001	
Timing belt, axis 3	3HAC061936-001	
Lower arm cover	3HAC069057-001	
Lower arm cover, Clean Room	3HAC075503-001	Used with protection type Clean Room.
Lower arm support cover	3HAC069059-001	
Lower arm support cover, Clean Room	3HAC075505-001	Used with protection type Clean Room.

Continues on next page

5 Repair

5.7.3 Replacing the axis-3 motor

Continued

Spare part	Article number	Note
Gasket for lower arm cover	3HAC061959-006	Used with protection class IP67 and protection type Clean Room. Replace if damaged.
Gasket for lower arm support cover	3HAC065331-001	Used with protection class IP67 and protection type Clean Room. Replace if damaged.
Cooling pad for axis-3 and -4 motors	3HAC071021-001	Cooling pads are wear parts. One cooling pad sheet includes 10 pieces of small pad. Replace if damaged with one piece each time.
Washer	3HAC063985-001	9x4.3x1, Steel

Required tools and equipment

Equipment	Article number	Note
Standard toolkit	-	Content is defined in section Standard toolkit on page 733 .
Calibration tool box, Axis Calibration	3HAC074119-001	Delivered as a set of calibration tools. Required if Axis Calibration is the valid calibration method for the robot. The tool box also includes a unique calibration pin for IRB 1100 to be fitted to the tool flange during calibration of axis 6.
24 VDC power supply	-	Used to release the motor brakes.
Sonic tension meter	-	Used for measuring the timing belt tension.
Dynamometer	-	Used for measuring the timing belt tension.

Required consumables

Consumable	Article number	Note
Cable straps	-	
Grease	3HAC029132-001	FM 222

Continues on next page

Deciding calibration routine

Decide which calibration routine to be used, based on the information in the table. Depending on which routine is chosen, action might be required prior to beginning the repair work of the robot, see the table.

	Action	Note
1	<p>Decide which calibration routine to use for calibrating the robot.</p> <ul style="list-style-type: none"> Reference calibration. External cable packages (DressPack) and tools can stay fitted on the robot. Fine calibration. All external cable packages (DressPack) and tools must be removed from the robot. 	<p> Note</p> <p>Calibrating axis 6 always requires tools to be removed from the mounting flange (also for reference calibration) since the mounting flange is used for installation of the calibration tool.</p>
	<p>If the robot is to be calibrated with reference calibration:</p> <p>Find previous reference values for the axis or create new reference values. These values are to be used after the repair procedure is completed, for calibration of the robot.</p> <p>If no previous reference values exist, and no new reference values can be created, then reference calibration is not possible.</p>	<p>Follow the instructions given in the reference calibration routine on the FlexPendant to create reference values.</p> <p>Creating new values requires possibility to move the robot.</p> <p>Read more about reference calibration for Axis Calibration in Reference calibration routine on page 696.</p>
	<p>If the robot is to be calibrated with fine calibration:</p> <p>Remove all external cable packages (DressPack) and tools from the robot.</p>	

Removing the motor

Use these procedures to remove the axis-3 motor.

Preparations before removing the axis-3 motor

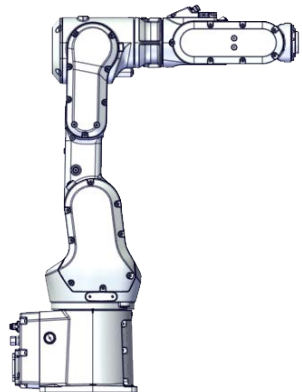

	Action	Note
1	Decide which calibration routine to use, and take actions accordingly prior to beginning the repair procedure.	
2	Jog all axes to zero position.	 <p>xx1800003288</p>

Continues on next page



5 Repair

5.7.3 Replacing the axis-3 motor



Continued

	Action	Note
3	 DANGER Turn off all: <ul style="list-style-type: none"> • electric power supply • hydraulic pressure supply • air pressure supply to the robot, before entering the safeguarded space.	
4	 CAUTION For robots with protection type Clean Room Always cut the paint with a knife and grind the paint edge when disassembling parts of the robot! See Cut the paint or surface on the robot before replacing parts on page 124 .	

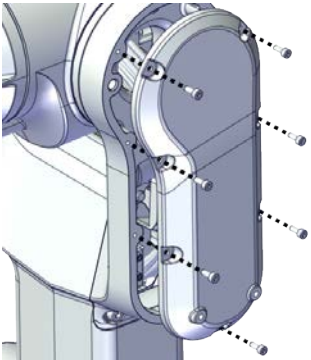
Disconnecting the axis-3 motor connectors

	Action	Note
1	 DANGER Make sure that all supplies for electrical power, hydraulic pressure, and air pressure are turned off.	
2	 CAUTION For robots with protection type Clean Room Always cut the paint with a knife and grind the paint edge when disassembling parts of the robot! See Cut the paint or surface on the robot before replacing parts on page 124 .	
3	Remove the lower arm support cover.	 xx1800003003

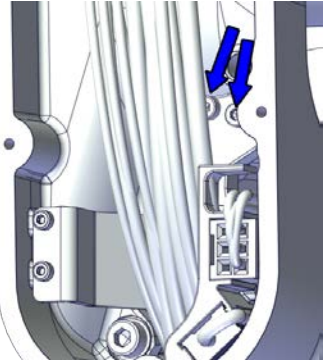
Continues on next page

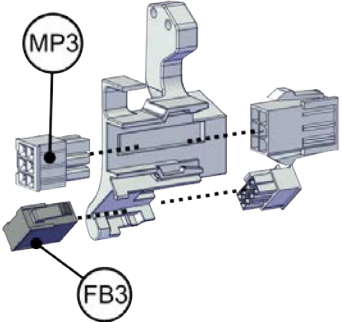
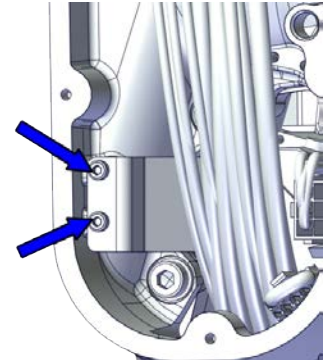
	Action	Note
4	<p>Remove the connector plate.</p> <p> CAUTION</p> <p>Be aware of the cabling that are attached to the connector plate! The connector plate cannot be removed completely until the connectors are removed from the plate, as shown in following step.</p>	 <p>xx1800003004</p>
5	<p>Slide the connectors out of the connector plate and disconnect the connectors.</p> <ul style="list-style-type: none"> • FB3 • MP3 <p> Tip</p> <p>Take photos of the connector and cable position before disconnecting them, to have as a reference when reconnecting.</p>	 <p>xx1800003005</p>
6	<p>Remove the cable bracket.</p>	 <p>xx1800003006</p>

Removing the axis-3 motor



	Action	Note
1	<p> DANGER</p> <p>Make sure that all supplies for electrical power, hydraulic pressure, and air pressure are turned off.</p>	

Continues on next page



5 Repair

5.7.3 Replacing the axis-3 motor

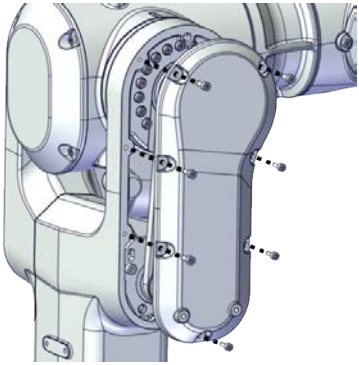
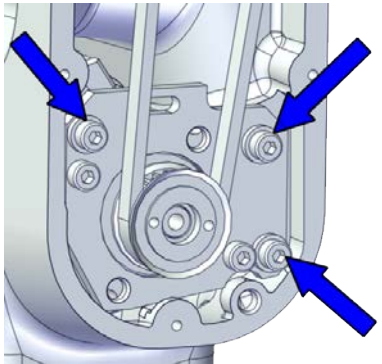
Continued

	Action	Note
2	 CAUTION For robots with protection type Clean Room Always cut the paint with a knife and grind the paint edge when disassembling parts of the robot! See <i>Cut the paint or surface on the robot before replacing parts on page 124.</i>	
3	 CAUTION Removing motors will release axes. This means the axes can fall down. Make sure axes are well supported before removing motors.	
4	Remove the lower arm cover.	 xx1800003007
5	Loosen the screws and move the motor slightly to slacken the timing belt.	 xx1800003008

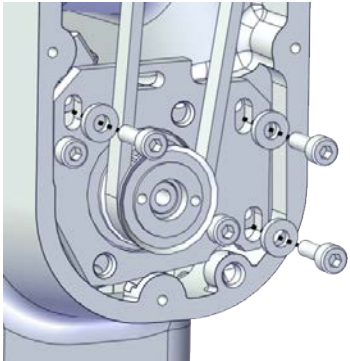
Continues on next page

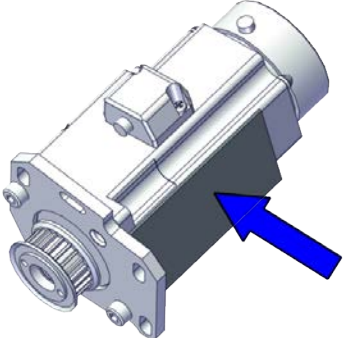
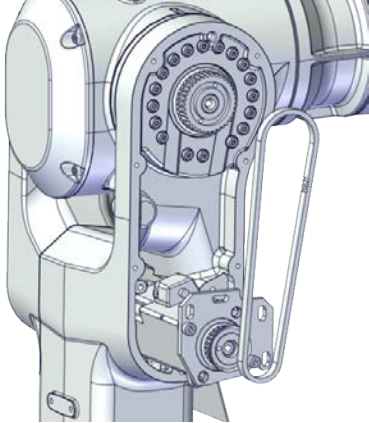
	Action	Note
6	Remove the screws and washers.	 <p>xx1800003009</p>
7	<p>Carefully lift out the motor.</p> <p> CAUTION</p> <p>A cooling pad is attached to the motor, which may stick to the casting. Always use a plastic sheet with caution to remove the pad from the casting. Pay attention not to scratch the casting or damage the pad.</p>	<p>Cooling pad location</p>  <p>xx1800003604</p>
8	Remove the timing belt from its groove on the motor.	 <p>xx1800003010</p>

Continues on next page

5 Repair

5.7.3 Replacing the axis-3 motor

Continued



Refitting the motor

Use these procedures to refit the axis-3 motor.

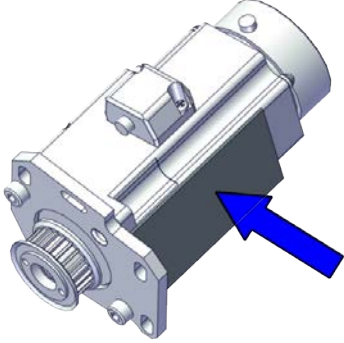
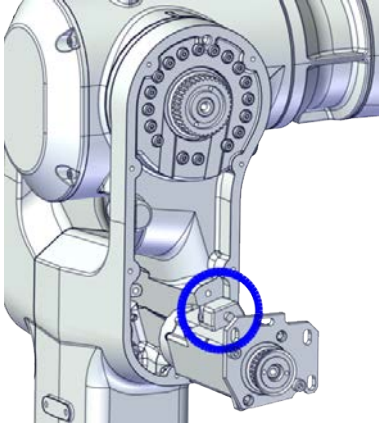
Refitting the axis-3 motor

	Action	Note
1	For robots with protection type Clean Room: Clean the joints that have been opened and wipe the parts free from particles with spirit on a lint free.	
2	Check that: <ul style="list-style-type: none">• all assembly surfaces are clean and without damages• the motor is clean and undamaged.	
3	Check the cooling pad. Replace if damaged.	Cooling pad for axis-3 and -4 motors: 3HAC071021-001  xx1800003604
4	Orient the motor correctly and fit it into the lower arm.	Motor orientation: orient the motor according to the figure below, in regard to the encircled motor connector.  xx1800003021

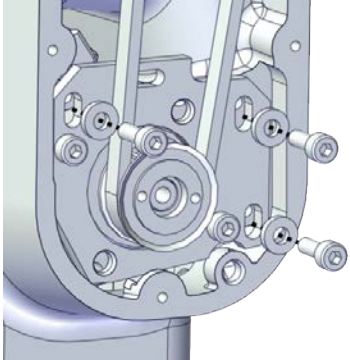
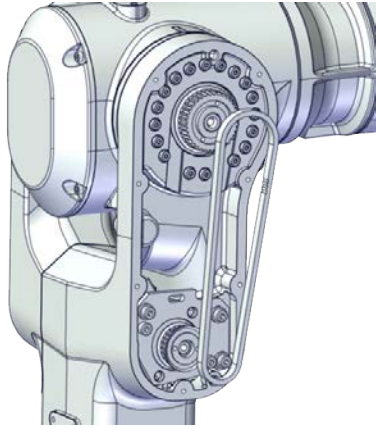
Continues on next page

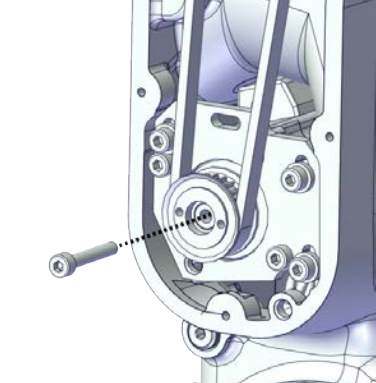
	Action	Note
5	<p>Refit the screws and washers.</p> <p> Note</p> <p>Do not tighten the screws yet.</p>	<p>Screw: M4x12 12.9 Lafre 2C2B/FC6.9 (3 pcs) Washer, 3HAC063985-001 (3 pcs)</p>  <p>xx1800003009</p>
6	<p>Install the timing belt to the pulleys and verify that the belt runs correctly in the grooves of the pulleys.</p>	 <p>xx1800003022</p>
7	<p>Install an M4x25 or longer adjustment screw to the motor.</p> <p> Note</p> <p>Do not insert the entire screw to the hole.</p>	 <p>xx1900000009</p>

Continues on next page

5 Repair

5.7.3 Replacing the axis-3 motor

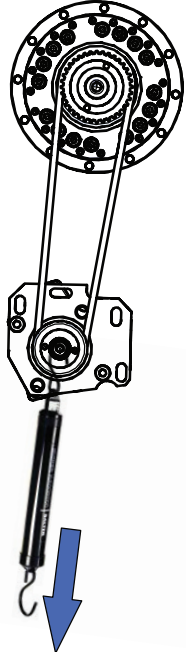
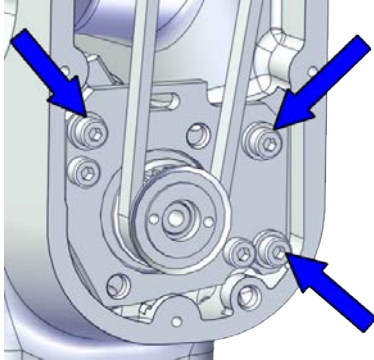

Continued

	Action	Note
8	Use a handheld dynamometer hooking to the screw and pull the dynamometer to reach the initial referenced force.	<p>Initial referenced force for used belt: 21.7-23.94 N (for reference only) Initial referenced force for new belt: 31-34.2 N</p>  <p>xx1900000028</p>
9	Secure the motor with the screws.	<p>Tightening torque: 3 Nm</p>  <p>xx1800003008</p>
10	Use a sonic tension meter to measure the timing belt tension.	<p>Used belt: 102-109 Hz New belt: 113-143 Hz (for reference only)</p>
11	If the timing belt tension does not meet the requirement, loosen the motor screws and readjust.	

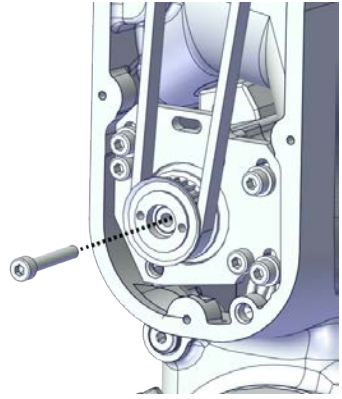
Continues on next page

	Action	Note
12	Remove the adjustment screw from the motor.	 <p>xx1900000009</p>

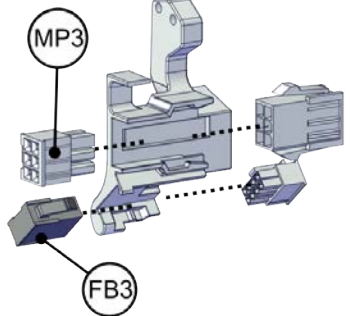
Reconnecting the axis-3 motor connectors

	Action	Note
1	For robots with protection type Clean Room: Clean the joints that have been opened and wipe the parts free from particles with spirit on a lint free.	
2	Slide the connectors into the connector plate and reconnect the connectors. <ul style="list-style-type: none"> • FB3 • MP3  Tip See the number markings on the connectors for help to find the corresponding connector.	 <p>xx1800003005</p>
3	Route and secure the cabling with cable straps.  CAUTION Correct cable routing is highly important. If the cables are routed and secured incorrectly the cables can be damaged.	

Continues on next page

5 Repair

5.7.3 Replacing the axis-3 motor

Continued

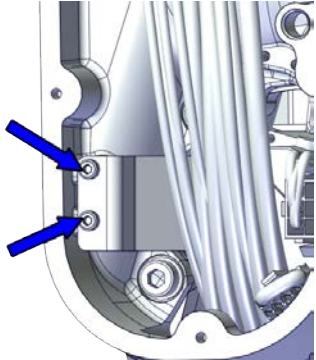
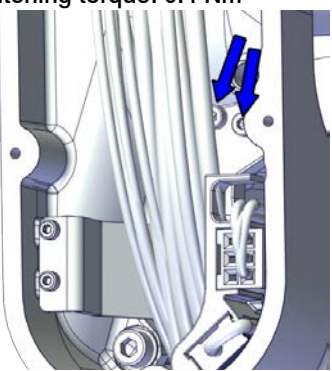
	Action	Note
4	Refit the cable bracket.	<p>Screw: M2.5x6 12.9 Lafre 2C2B/FC6.9 (2 pcs) Tightening torque: 0.6 Nm</p>  <p>xx1800003006</p>
5	Refit the connector plate.	<p>Screw: M3x12 12.9 Lafre 2C2B/FC6.9 (2 pcs) Tightening torque: 0.4 Nm</p>  <p>xx1800003004</p>

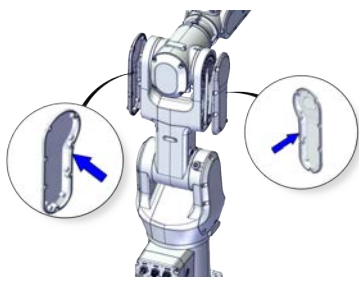

Refitting the lower arm covers

	Action	Note
1	For robots with protection type Clean Room: Clean the joints that have been opened and wipe the parts free from particles with spirit on a lint free.	
2	<p>For robots with protection class IP67 (option 3350-670) For robots with protection type Clean Room (option 3351-4) Check the gaskets. Replace if damaged.</p>	 <p>xx1900002179</p>
3	Apply grease to the cable package, cover all moving area of the package.	

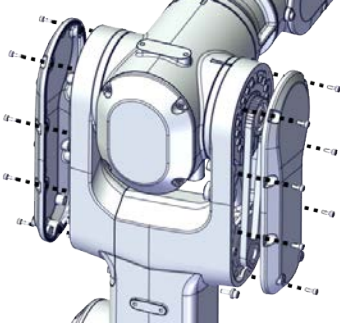
Continues on next page

	Action	Note
4	Apply grease to the covers that have contacting area with the cable package.	
5	Refit the covers. <ul style="list-style-type: none"> • Lower arm cover • Lower arm support cover 	Screw: M3x8 12.9 Lafre 2C2B/FC6.9 Tightening torque: 1.2 Nm  xx1800003608

Concluding procedure

	Action	Note
1	For robots with protection type Clean Room: Clean and paint the joints that have been opened. See Cut the paint or surface on the robot before replacing parts on page 124  Note After all repair work, wipe the Clean Room robot free from particles with spirit on a lint free cloth.	
2	Recalibrate the robot.	Calibration is detailed in section Calibration on page 685 .
3	 DANGER Make sure all safety requirements are met when performing the first test run. See Test run after installation, maintenance, or repair on page 91 .	

5 Repair

5.7.4 Replacing the axis-4 motor

5.7.4 Replacing the axis-4 motor

Location of the axis-4 motor

The xx is located as shown in the figure.

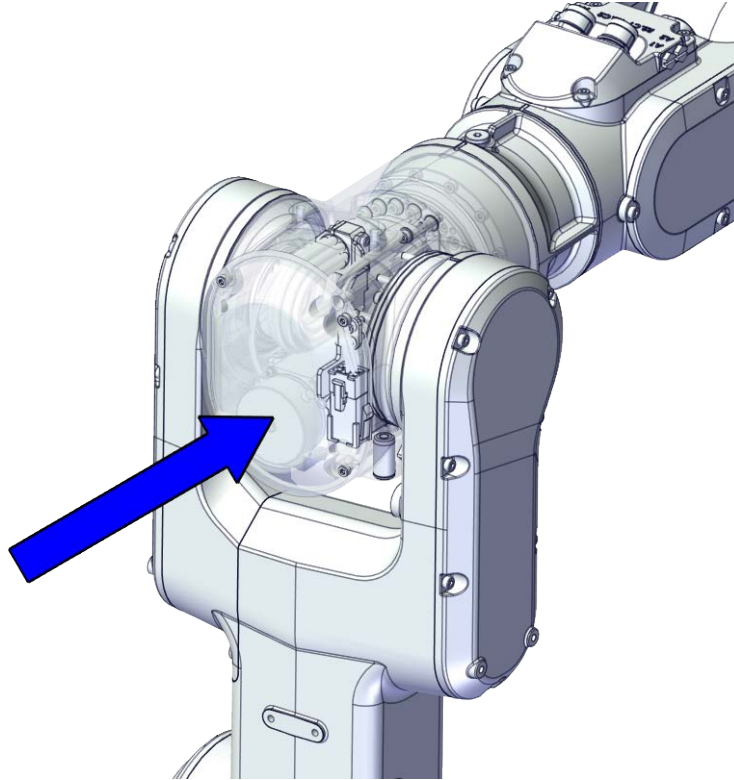

xx1800002485

Required spare parts



Note

The spare part numbers that are listed in the table can be out of date. See the latest spare parts of the IRB 1100 via myABB Business Portal, www.abb.com/myABB.

Spare part	Article number	Note
Motor with flange, axis 4	3HAC083586-001	
Timing belt, axis 4	3HAC061937-001	
Housing cover	3HAC069054-001	
Housing cover, Clean Room	3HAC075501-001	Used with protection type Clean Room.
Gasket for housing cover	3HAC061959-007	Used with protection class IP67 and protection type Clean Room. Replace if damaged.

Continues on next page

Spare part	Article number	Note
Cooling pad for axis-3 and -4 motors	3HAC071021-001	Cooling pads are wear parts. One cooling pad sheet includes 10 pieces of small pad. Replace if damaged with one piece each time.
Washer	3HAC064765-001	7x3.2x1.5, Steel
Rubber sealing washer on housing	3HAC064147-001	Used with protection class IP67 and protection type Clean Room. Replace if damaged.
Plug screw	3HAC064146-001	Used with protection classes IP40 and IP67. Replace if damaged.
Plug screw, Clean Room	3HAC070309-001	Used with protection type Clean Room. Replace if damaged.

Required tools and equipment

Equipment	Article number	Note
Standard toolkit	-	Content is defined in section Standard toolkit on page 733 .
Calibration tool box, Axis Calibration	3HAC074119-001	Delivered as a set of calibration tools. Required if Axis Calibration is the valid calibration method for the robot. The tool box also includes a unique calibration pin for IRB 1100 to be fitted to the tool flange during calibration of axis 6.
24 VDC power supply	-	Used to release the motor brakes.
M3x25 eye bolt	-	Included in the special toolkit 3HAC071022-001.
axis-4 motor fitting tool	-	Included in the special toolkit 3HAC071022-001. Used to refit the axis-4 motor.
Dynamometer	-	Used for measuring the timing belt tension.

Required consumables

Consumable	Article number	Note
Cable straps	-	
Grease	3HAC029132-001	FM 222

Continues on next page

5 Repair

5.7.4 Replacing the axis-4 motor

Continued

Deciding calibration routine

Decide which calibration routine to be used, based on the information in the table. Depending on which routine is chosen, action might be required prior to beginning the repair work of the robot, see the table.

	Action	Note
1	<p>Decide which calibration routine to use for calibrating the robot.</p> <ul style="list-style-type: none"> Reference calibration. External cable packages (DressPack) and tools can stay fitted on the robot. Fine calibration. All external cable packages (DressPack) and tools must be removed from the robot. 	<p> Note</p> <p>Calibrating axis 6 always requires tools to be removed from the mounting flange (also for reference calibration) since the mounting flange is used for installation of the calibration tool.</p>
	<p>If the robot is to be calibrated with reference calibration:</p> <p>Find previous reference values for the axis or create new reference values. These values are to be used after the repair procedure is completed, for calibration of the robot.</p> <p>If no previous reference values exist, and no new reference values can be created, then reference calibration is not possible.</p>	<p>Follow the instructions given in the reference calibration routine on the FlexPendant to create reference values.</p> <p>Creating new values requires possibility to move the robot.</p> <p>Read more about reference calibration for Axis Calibration in Reference calibration routine on page 696.</p>
	<p>If the robot is to be calibrated with fine calibration:</p> <p>Remove all external cable packages (DressPack) and tools from the robot.</p>	



Removing the motor

Use these procedures to remove the axis-4 motor.

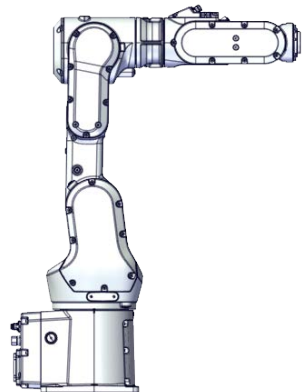

Preparations before removing the axis-4 motor

	Action	Note
1	Decide which calibration routine to use, and take actions accordingly prior to beginning the repair procedure.	
2	Jog all axes to zero position.	 <p>xx1800003288</p>

Continues on next page

	Action	Note
3	 <p>DANGER</p> <p>Turn off all:</p> <ul style="list-style-type: none"> • electric power supply • hydraulic pressure supply • air pressure supply <p>to the robot, before entering the safeguarded space.</p>	
4	 <p>CAUTION</p> <p>For robots with protection type Clean Room Always cut the paint with a knife and grind the paint edge when disassembling parts of the robot! See Cut the paint or surface on the robot before replacing parts on page 124.</p>	

Disconnecting the axis-4 motor connectors

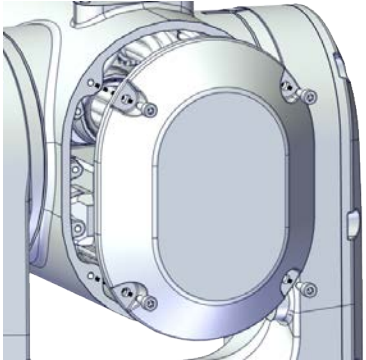
	Action	Note
1	 <p>DANGER</p> <p>Make sure that all supplies for electrical power, hydraulic pressure, and air pressure are turned off.</p>	
2	 <p>CAUTION</p> <p>For robots with protection type Clean Room Always cut the paint with a knife and grind the paint edge when disassembling parts of the robot! See Cut the paint or surface on the robot before replacing parts on page 124.</p>	
3	Remove the housing cover.	 <p>xx1800003011</p>

Continues on next page



5 Repair

5.7.4 Replacing the axis-4 motor

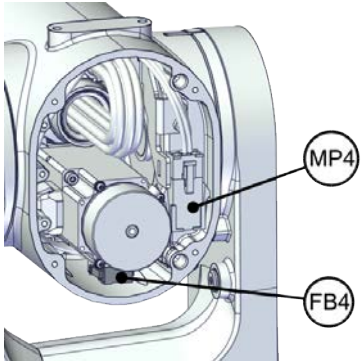

Continued

	Action	Note
4	Disconnect the motor connectors. <ul style="list-style-type: none"> • FB4 • MP4 	 <p>xx1800003012</p>

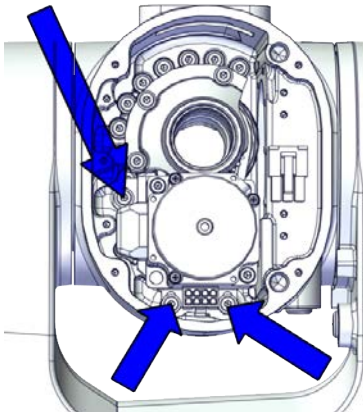
Removing the axis-4 motor

	Action	Note
1	 DANGER Make sure that all supplies for electrical power, hydraulic pressure, and air pressure are turned off.	
2	 CAUTION For robots with protection type Clean Room Always cut the paint with a knife and grind the paint edge when disassembling parts of the robot! See Cut the paint or surface on the robot before replacing parts on page 124.	
3	 CAUTION Removing motors will release axes. This means the axes can fall down. Make sure axes are well supported before removing motors.	
4	Loosen the screws and move the motor slightly to slacken the timing belt.	 <p>xx1800003094</p>

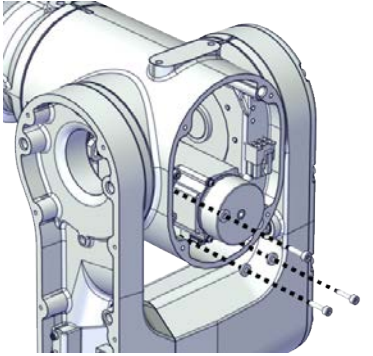
Continues on next page

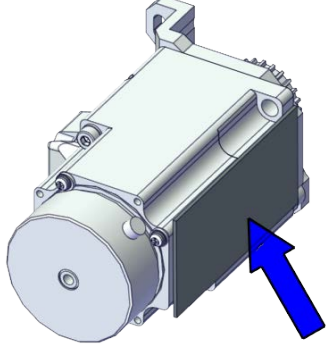
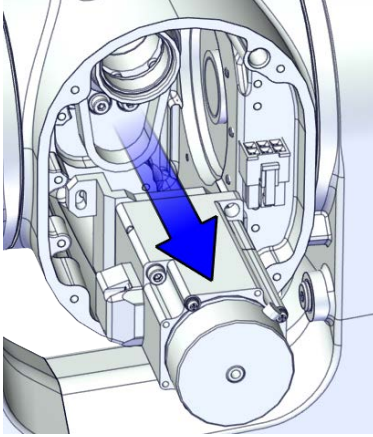
	Action	Note
5	Remove the screws and washers.	 <p>xx1800003095</p>
6	<p>Carefully lift out the motor.</p> <p> CAUTION</p> <p>A cooling pad is attached to the motor, which may stick to the casting. Always use a plastic sheet with caution to remove the pad from the casting. Pay attention not to scratch the casting or damage the pad.</p>	<p>Cooling pad location</p>  <p>xx1800003605</p>
7	Remove the timing belt from its groove on the motor.	 <p>xx1800003096</p>

Continues on next page

5 Repair

5.7.4 Replacing the axis-4 motor

Continued



Refitting the motor

Use these procedures to refit the axis-4 motor.

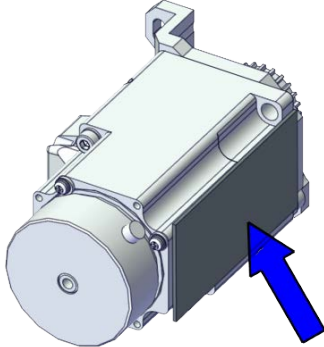
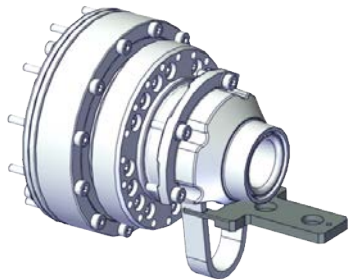
Refitting the axis-4 motor

	Action	Note
1	For robots with protection type Clean Room: Clean the joints that have been opened and wipe the parts free from particles with spirit on a lint free.	
2	Check that: <ul style="list-style-type: none">• all assembly surfaces are clean and without damages• the motor is clean and undamaged.	
3	Check the cooling pad. Replace if damaged.	Cooling pad for axis-3 and -4 motors: 3HAC071021-001  xx1800003605
4	Use the motor fitting tool to fix the timing belt.	axis-4 motor fitting tool, included in the special toolkit 3HAC071022-001.  xx1900000044

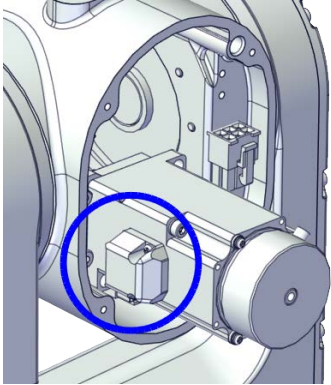
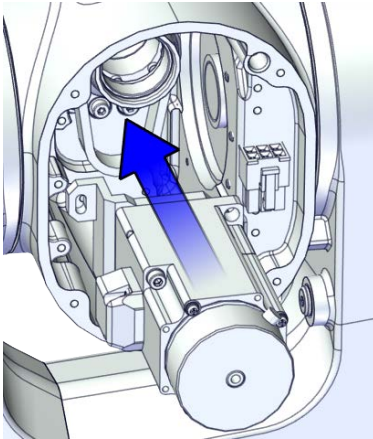
Continues on next page

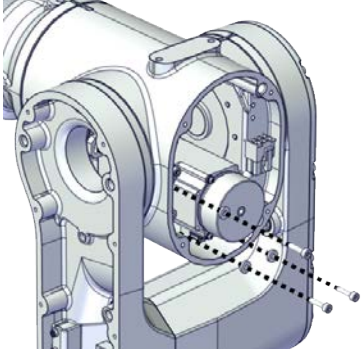
	Action	Note
5	<p>Orient the motor correctly and fit it into the housing.</p> <p> Note</p> <p>Make sure the motor flange does not press on the timing belt.</p>	<p>Motor orientation: orient the motor according to the figure below, in regard to the encircled motor connector.</p>  <p>xx1800003287</p>
6	<p>Install the timing belt to the motor pulley.</p>	 <p>xx1800003617</p>
7	<p>Refit the screws and washers.</p> <p> Note</p> <p>Do not tighten the screws yet.</p>	<p>Screw: M3x12 12.9 Lafre 2C2B/FC6.9 (3 pcs) Washer, 3HAC064765-001 (3 pcs)</p>  <p>xx1800003095</p>
8	<p>Remove the motor fitting tool.</p>	

Continues on next page

5 Repair

5.7.4 Replacing the axis-4 motor

Continued

Adjusting the axis-4 timing belt tension

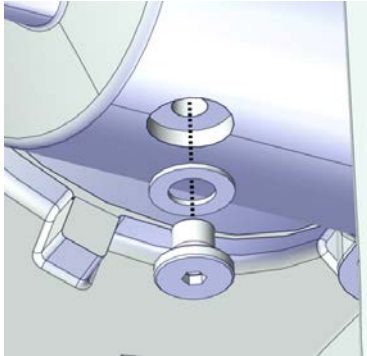
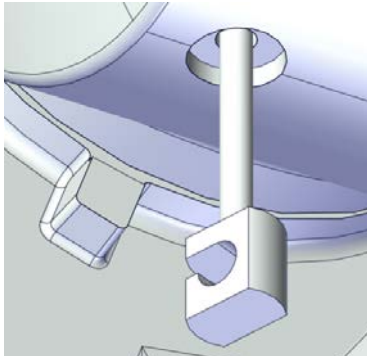
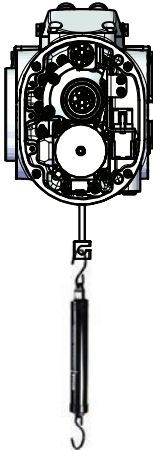
	Action	Note
1	For robots with protection type Clean Room: Clean the joints that have been opened and wipe the parts free from particles with spirit on a lint free.	
2	Remove the screw and washer below the housing.	 xx1900000036
3	Fit an M3x25 eye bolt to the screw hole.	 xx1900000037
4	Use a handheld dynamometer hooking to the eye bolt.	 xx1900000038

Continues on next page

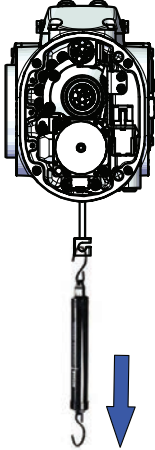
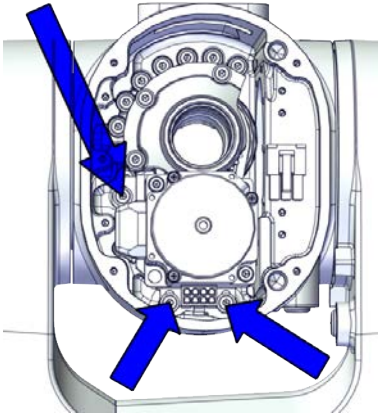
	Action	Note
5	<p>Pull the dynamometer to make the tension falling in the allowed force range.</p> <p> Note Pay attention to the force application direction.</p>	<p>Used belt: 20.09-22.05 N New belt: 28.7-31.5 N</p>  <p>xx1900000039</p>
6	<p>Secure the motor with the screws.</p>	<p>Tightening torque: 1.4 Nm</p>  <p>xx1800003094</p>
7	<p>Remove eye bolt and refit the screw and washer below the housing.</p>	<p>Plug screw: 3HAC064146-001 For robots with protection type Clean Room (option 3351-4) Plug screw, Clean Room: 3HAC070309-001 For robots with protection class IP67 (option 3350-670) For robots with protection type Clean Room (option 3351-4) Rubber sealing washer on housing: 3HAC064147-001 Tightening torque: 2 Nm</p>



Continues on next page

5 Repair

5.7.4 Replacing the axis-4 motor

Continued

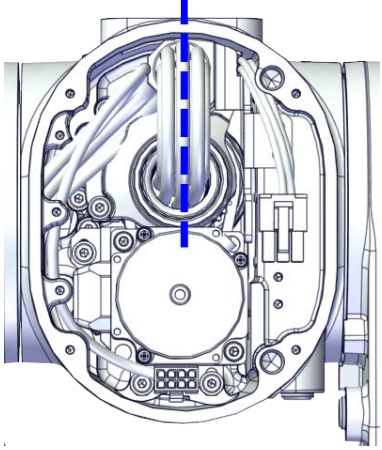
Reconnecting the axis-4 motor connectors

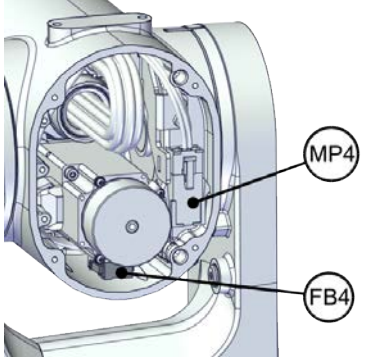
	Action	Note
1	For robots with protection type Clean Room: Clean the joints that have been opened and wipe the parts free from particles with spirit on a lint free.	
2	Check the cabling status. Make sure the cabling is in vertical state and is not twisted.	 xx1800003618
3	Reconnect the connectors. <ul style="list-style-type: none"> • FB4 • MP4  Tip See the number markings on the connectors for help to find the corresponding connector.	 xx1800003012

Refitting the housing cover

	Action	Note
1	For robots with protection type Clean Room: Clean the joints that have been opened and wipe the parts free from particles with spirit on a lint free.	

Continues on next page

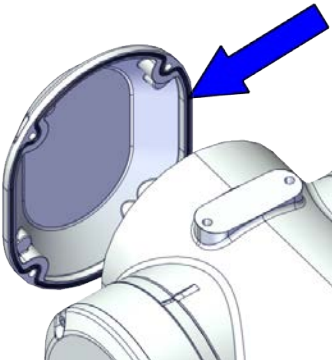
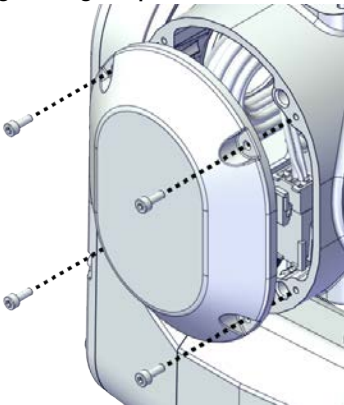
	Action	Note
2	<p>For robots with protection class IP67 (option 3350-670)</p> <p>For robots with protection type Clean Room (option 3351-4)</p> <p>Check the gasket.</p> <p>Replace if damaged.</p>	<p>Gasket for housing cover: 3HAC061959-007</p>  <p>xx1900002180</p>
3	<p>Apply grease to the cable package, cover all moving area of the package.</p>	
4	<p>Apply grease to the covers that have contacting area with the cable package.</p>	
5	<p>Refit the housing cover.</p>	<p>Screw: M3x8 12.9 Lafre 2C2B/FC6.9 (4 pcs)</p> <p>Tightening torque: 1.2 Nm</p>  <p>xx1800003609</p>

Concluding procedure

	Action	Note
1	<p>For robots with protection type Clean Room: Clean and paint the joints that have been opened. See Cut the paint or surface on the robot before replacing parts on page 124</p> <p> Note</p> <p>After all repair work, wipe the Clean Room robot free from particles with spirit on a lint free cloth.</p>	
2	<p>Recalibrate the robot.</p>	<p>Calibration is detailed in section Calibration on page 685.</p>

Continues on next page

5 Repair

5.7.4 Replacing the axis-4 motor

Continued

	Action	Note
3	 DANGER Make sure all safety requirements are met when performing the first test run. See Test run after installation, maintenance, or repair on page 91 .	

5.7.5 Replacing the axis-5 motor

Location of the axis-5 motor

The axis-5 motor is located as shown in the figure.

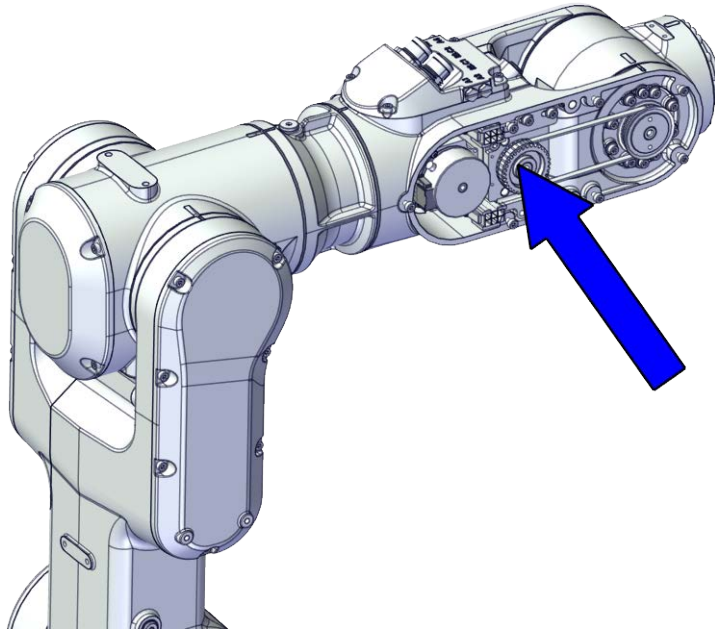

xx1800002486

Required spare parts



Note

The spare part numbers that are listed in the table can be out of date. See the latest spare parts of the IRB 1100 via myABB Business Portal, www.abb.com/myABB.

Spare part	Article number	Note
Motor with flange, axis 5	3HAC083585-001	
Timing belt, axis 5	3HAC061938-001	
Wrist cover	3HAC069061-001	
Wrist cover, Clean Room	3HAC075507-001	Used with protection type Clean Room.
Gasket for wrist cover	3HAC061959-009	Used with protection class IP67 and protection type Clean Room. Replace if damaged.

Continues on next page

5 Repair

5.7.5 Replacing the axis-5 motor

Continued

Spare part	Article number	Note
Gasket for process hub	3HAC065352-001	Used with protection class IP67 and protection type Clean Room. Replace if damaged.

Required tools and equipment

Equipment	Article number	Note
Standard toolkit	-	Content is defined in section Standard toolkit on page 733 .
Calibration tool box, Axis Calibration	3HAC074119-001	Delivered as a set of calibration tools. Required if Axis Calibration is the valid calibration method for the robot. The tool box also includes a unique calibration pin for IRB 1100 to be fitted to the tool flange during calibration of axis 6.
24 VDC power supply	-	Used to release the motor brakes.
Sonic tension meter	-	Used for measuring the timing belt tension.
Dynamometer	-	Used for measuring the timing belt tension.
J5.C2 connector assembly tool	-	Included in the special toolkit 3HAC071022-001. Used to remove and refit the J5.C2 connector, if the Ethernet cabling is equipped.

Required consumables

Consumable	Article number	Note
Cable straps	-	
Grease	3HAC029132-001	FM 222

Deciding calibration routine

Decide which calibration routine to be used, based on the information in the table. Depending on which routine is chosen, action might be required prior to beginning the repair work of the robot, see the table.

	Action	Note
1	Decide which calibration routine to use for calibrating the robot. <ul style="list-style-type: none"> Reference calibration. External cable packages (DressPack) and tools can stay fitted on the robot. Fine calibration. All external cable packages (DressPack) and tools must be removed from the robot. 	 Note Calibrating axis 6 always requires tools to be removed from the mounting flange (also for reference calibration) since the mounting flange is used for installation of the calibration tool.



Continues on next page

Action	Note
<p>If the robot is to be calibrated with reference calibration:</p> <p>Find previous reference values for the axis or create new reference values. These values are to be used after the repair procedure is completed, for calibration of the robot.</p> <p>If no previous reference values exist, and no new reference values can be created, then reference calibration is not possible.</p>	<p>Follow the instructions given in the reference calibration routine on the FlexPendant to create reference values.</p> <p>Creating new values requires possibility to move the robot.</p> <p>Read more about reference calibration for Axis Calibration in Reference calibration routine on page 696.</p>
<p>If the robot is to be calibrated with fine calibration:</p> <p>Remove all external cable packages (DressPack) and tools from the robot.</p>	

Removing the motor

Use these procedures to remove the axis-5 motor.

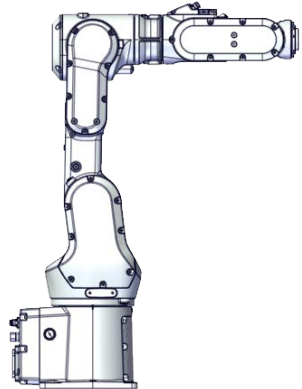
Preparations before removing the axis-5 motor

	Action	Note
1	Decide which calibration routine to use, and take actions accordingly prior to beginning the repair procedure.	
2	Jog all axes to zero position.	 <p>xx1800003288</p>
3	 <p>DANGER</p> <p>Turn off all:</p> <ul style="list-style-type: none"> • electric power supply • hydraulic pressure supply • air pressure supply <p>to the robot, before entering the safeguarded space.</p>	

Continues on next page



5 Repair

5.7.5 Replacing the axis-5 motor

Continued

	Action	Note
4	 CAUTION For robots with protection type Clean Room Always cut the paint with a knife and grind the paint edge when disassembling parts of the robot! See Cut the paint or surface on the robot before replacing parts on page 124 .	

Opening the process hub

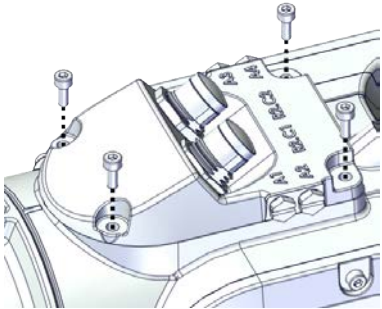
	Action	Note
1	 DANGER Make sure that all supplies for electrical power, hydraulic pressure, and air pressure are turned off.	
2	 CAUTION For robots with protection type Clean Room Always cut the paint with a knife and grind the paint edge when disassembling parts of the robot! See Cut the paint or surface on the robot before replacing parts on page 124 .	
3	Remove the screws and carefully open the cover.  CAUTION Be aware of the cabling that is attached to the cover!	 xx1800002944



Removing the wrist cover

	Action	Note
1	 DANGER Make sure that all supplies for electrical power, hydraulic pressure, and air pressure are turned off.	

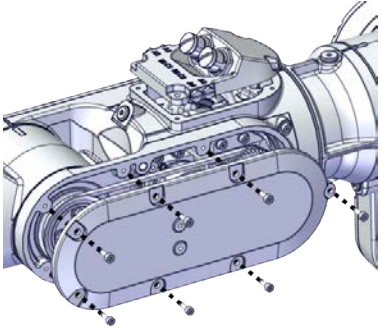
Continues on next page

	Action	Note
2	<p> CAUTION</p> <p>For robots with protection type Clean Room Always cut the paint with a knife and grind the paint edge when disassembling parts of the robot! See <i>Cut the paint or surface on the robot before replacing parts on page 124.</i></p>	
3	<p>Remove the wrist cover (right one when facing the robot rear).</p>	 <p>xx1800003315</p>

Disconnecting the axis-5 motor connectors

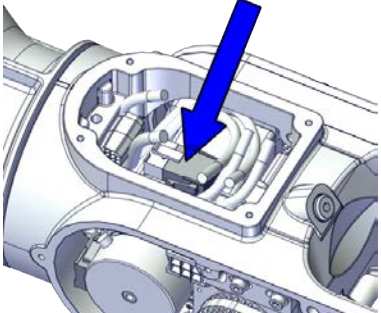
	Action	Note
1	<p> DANGER</p> <p>Make sure that all supplies for electrical power, hydraulic pressure, and air pressure are turned off.</p>	
2	<p> CAUTION</p> <p>For robots with protection type Clean Room Always cut the paint with a knife and grind the paint edge when disassembling parts of the robot! See <i>Cut the paint or surface on the robot before replacing parts on page 124.</i></p>	
3	<p>Access the connector FB5 from the process hub and disconnect the connector.</p>	 <p>xx1800002950</p>

Continues on next page



5 Repair

5.7.5 Replacing the axis-5 motor

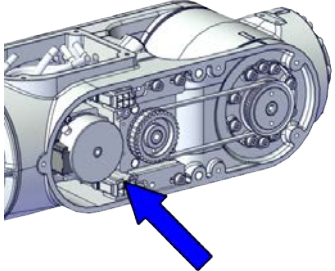
Continued

	Action	Note
4	Disconnect the connector. <ul style="list-style-type: none"> MP5 	 <p>xx1800002993</p>

Removing the axis-5 motor

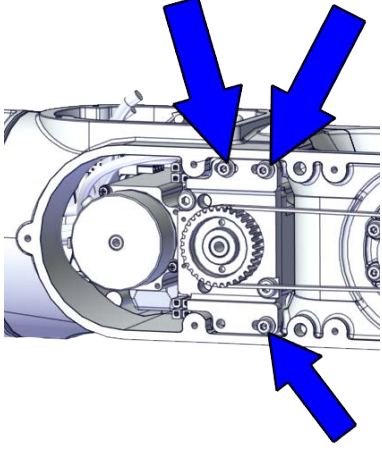
	Action	Note
1	 DANGER Make sure that all supplies for electrical power, hydraulic pressure, and air pressure are turned off.	
2	 CAUTION For robots with protection type Clean Room Always cut the paint with a knife and grind the paint edge when disassembling parts of the robot! See Cut the paint or surface on the robot before replacing parts on page 124.	
3	 CAUTION Removing motors will release axes. This means the axes can fall down. Make sure axes are well supported before removing motors.	
4	Loosen the screws and move the motor slightly to slacken the timing belt.	 <p>xx1800003290</p>

Continues on next page

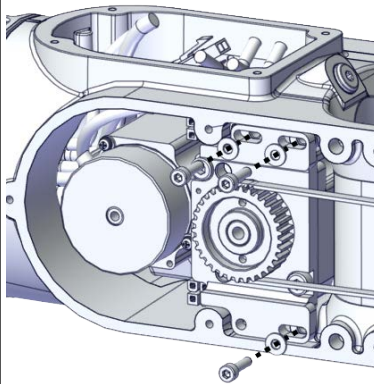
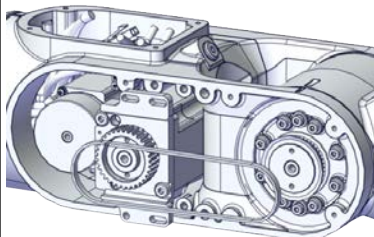
	Action	Note
5	Remove the screws and washers.	 <p>xx1800003291</p>
6	Carefully lift out the motor.	
7	Remove the timing belt from its groove on the motor.	 <p>xx1800003292</p>

Refitting the motor

Use these procedures to refit the axis-5 motor.

Refitting the axis-5 motor



	Action	Note
1	For robots with protection type Clean Room: Clean the joints that have been opened and wipe the parts free from particles with spirit on a lint free.	
2	Check that: <ul style="list-style-type: none"> • all assembly surfaces are clean and without damages • the motor is clean and undamaged. 	

Continues on next page

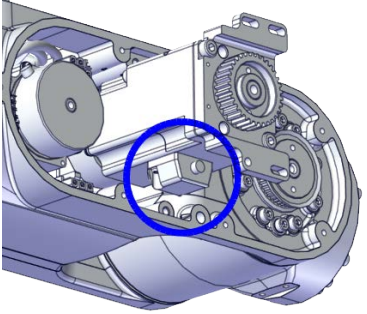

5 Repair

5.7.5 Replacing the axis-5 motor

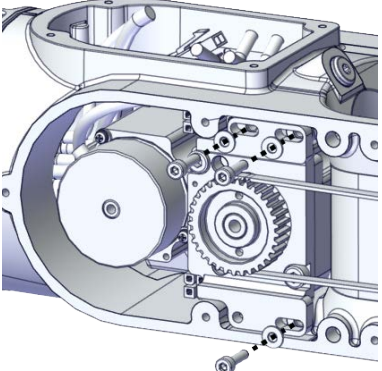
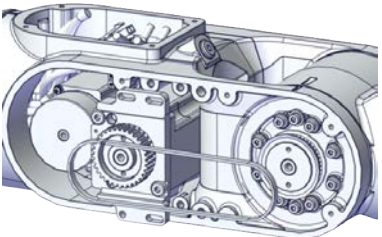
Continued

	Action	Note
3	<p>Orient the motor correctly and fit it into the wrist.</p> <p> Tip</p> <p>Leave the connectors FB5 and FB6 accessible from the process hub and the connectors MP5 and MP6 accessible from wrist side.</p>	<p>Motor orientation: orient the motor according to the figure below, in regard to the encircled motor connector.</p>  <p>xx1800003296</p>
4	<p>Refit the screws and washers.</p> <p> Note</p> <p>Do not tighten the screws yet.</p>	<p>Screw: M3x12 12.9 Lafre 2C2B/FC6.9 (3 pcs)</p>  <p>xx1800003291</p>
5	<p>Install the timing belt to the pulleys and verify that the belt runs correctly in the grooves of the pulleys.</p>	 <p>xx1800003292</p>

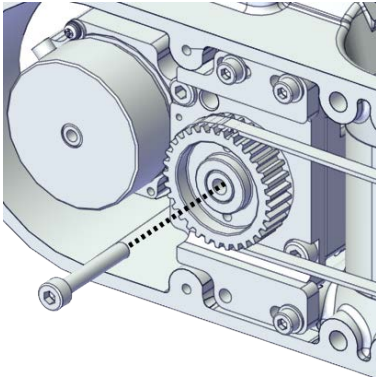
Continues on next page

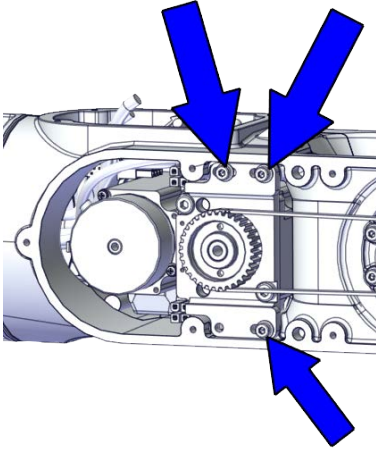
	Action	Note
6	Install an M4x25 or longer adjustment screw to the motor.  Note Do not insert the entire screw to the hole.	 xx190000008
7	Use a handheld dynamometer hooking to the screw and pull the dynamometer to reach the initial referenced force.	Initial referenced force for used belt: 13.58-14.84 N (for reference only) Initial referenced force for new belt: 19.4-21.2 N  xx190000027
8	Secure the motor with the screws.	Tightening torque: 1.4 Nm  xx1800003290
9	Use a sonic tension meter to measure the timing belt tension.	Used belt: 151-162 Hz New belt: 167-213 Hz (for reference only)
10	If the timing belt tension does not meet the requirement, loosen the motor screws and readjust.	

Continues on next page



5 Repair

5.7.5 Replacing the axis-5 motor

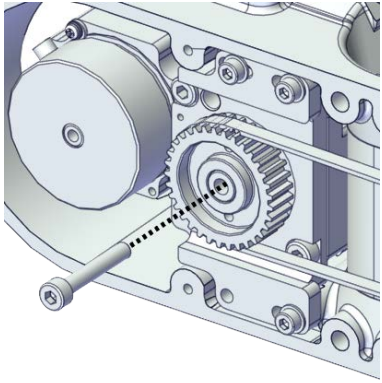
Continued

	Action	Note
11	Remove the adjustment screw from the motor.	 <p>xx190000008</p>

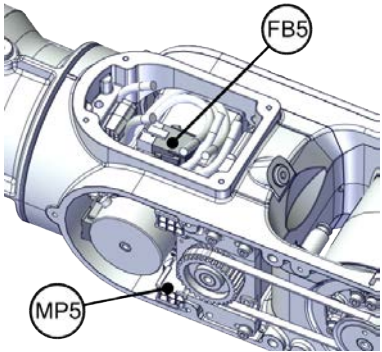
Reconnecting the axis-5 motor connectors

	Action	Note
1	For robots with protection type Clean Room: Clean the joints that have been opened and wipe the parts free from particles with spirit on a lint free.	
2	Reconnect the connectors. <ul style="list-style-type: none"> • FB5 • MP5  Tip See the number markings on the connectors for help to find the corresponding connector.	 <p>xx1800003025</p>
3	Route and secure the cabling with cable straps.  CAUTION Correct cable routing is highly important. If the cables are routed and secured incorrectly the cables can be damaged.	
4	Insert the cabling and connectors into the wrist.	

Refitting the wrist cover

	Action	Note
1	For robots with protection type Clean Room: Clean the joints that have been opened and wipe the parts free from particles with spirit on a lint free.	

Continues on next page

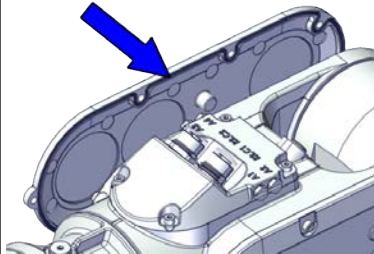
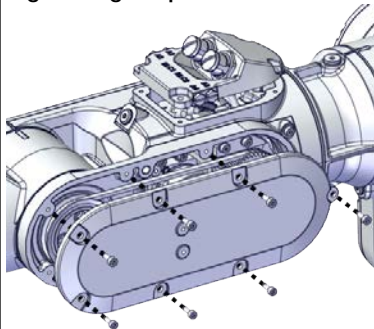
	Action	Note
2	<p>For robots with protection class IP67 (option 3350-670)</p> <p>For robots with protection type Clean Room (option 3351-4)</p> <p>Check the gasket.</p> <p>Replace if damaged.</p>	<p>Gasket for wrist cover: 3HAC061959-009</p>  <p>xx1900002181</p>
3	Apply grease to the cable package, cover all moving area of the package.	
4	Apply grease to the cover that has contacting area with the cable package.	
5	Refit the wrist cover.	<p>Screw: M3x8 12.9 Lafre 2C2B/FC6.9 (7 pcs)</p> <p>Tightening torque: 1.2 Nm</p>  <p>xx1800003315</p>

Refitting the process hub

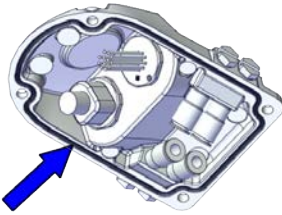
	Action	Note
1	For robots with protection type Clean Room: Clean the joints that have been opened and wipe the parts free from particles with spirit on a lint free.	
2	<p>For robots with protection class IP67 (option 3350-670)</p> <p>For robots with protection type Clean Room (option 3351-4)</p> <p>Check the gasket.</p> <p>Replace if damaged.</p>	<p>Gasket for process hub: 3HAC065352-001</p>  <p>xx1900002187</p>

Continues on next page



5 Repair

5.7.5 Replacing the axis-5 motor

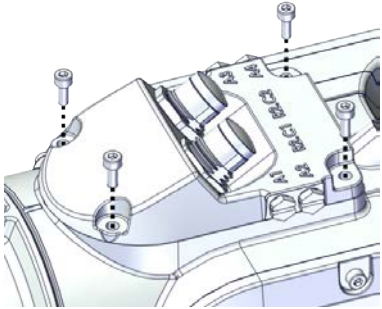
Continued

	Action	Note
3	<p>Route and secure the cabling with cable straps.</p> <p> CAUTION</p> <p>Correct cable routing is highly important. If the cables are routed and secured incorrectly the cables can be damaged.</p>	
4	<p>Refit the cover.</p>	<p>Screw: M3x8 12.9 Lafre 2C2B/FC6.9 (4 pcs) Tightening torque: 1.2 Nm</p>  <p>xx1800002944</p>

Concluding procedure

	Action	Note
1	<p>For robots with protection type Clean Room: Clean and paint the joints that have been opened. See Cut the paint or surface on the robot before replacing parts on page 124</p> <p> Note</p> <p>After all repair work, wipe the Clean Room robot free from particles with spirit on a lint free cloth.</p>	
2	<p>Recalibrate the robot.</p>	<p>Calibration is detailed in section Calibration on page 685.</p>
3	<p> DANGER</p> <p>Make sure all safety requirements are met when performing the first test run. See Test run after installation, maintenance, or repair on page 91.</p>	

5.7.6 Replacing the axis-6 motor

Location of the axis-6 motor

The xx is located as shown in the figure.

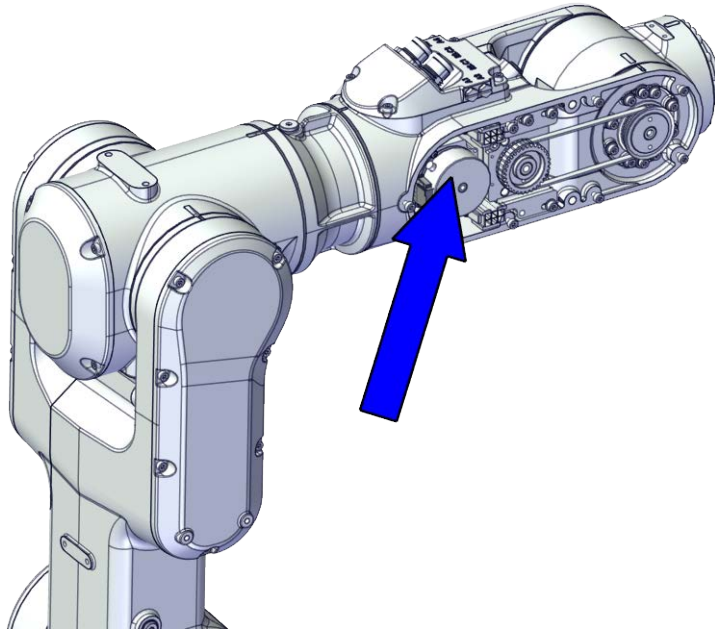

xx1800002487

Required spare parts



Note

The spare part numbers that are listed in the table can be out of date. See the latest spare parts of the IRB 1100 via myABB Business Portal, www.abb.com/myABB.

Spare part	Article number	Note
Motor with flange, axis 6	3HAC083584-001	
Timing belt, axis 6	3HAC061939-001	
Wrist cover	3HAC069061-001	
Wrist cover, Clean Room	3HAC075507-001	Used with protection type Clean Room.
Gasket for wrist cover	3HAC061959-009	Used with protection class IP67 and protection type Clean Room. Replace if damaged.

Continues on next page

5 Repair

5.7.6 Replacing the axis-6 motor

Continued

Spare part	Article number	Note
Gasket for process hub	3HAC065352-001	Used with protection class IP67 and protection type Clean Room. Replace if damaged.

Required tools and equipment

Equipment	Article number	Note
Standard toolkit	-	Content is defined in section Standard toolkit on page 733 .
Calibration tool box, Axis Calibration	3HAC074119-001	Delivered as a set of calibration tools. Required if Axis Calibration is the valid calibration method for the robot. The tool box also includes a unique calibration pin for IRB 1100 to be fitted to the tool flange during calibration of axis 6.
24 VDC power supply	-	Used to release the motor brakes.
Sonic tension meter	-	Used for measuring the timing belt tension.
Dynamometer	-	Used for measuring the timing belt tension.
J5.C2 connector assembly tool	-	Included in the special toolkit 3HAC071022-001. Used to remove and refit the J5.C2 connector, if the Ethernet cabling is equipped.

Required consumables

Consumable	Article number	Note
Cable straps	-	
Grease	3HAC029132-001	FM 222

Deciding calibration routine

Decide which calibration routine to be used, based on the information in the table. Depending on which routine is chosen, action might be required prior to beginning the repair work of the robot, see the table.

	Action	Note
1	Decide which calibration routine to use for calibrating the robot. <ul style="list-style-type: none"> Reference calibration. External cable packages (DressPack) and tools can stay fitted on the robot. Fine calibration. All external cable packages (DressPack) and tools must be removed from the robot. 	 Note Calibrating axis 6 always requires tools to be removed from the mounting flange (also for reference calibration) since the mounting flange is used for installation of the calibration tool.



Continues on next page

Action	Note
<p>If the robot is to be calibrated with reference calibration:</p> <p>Find previous reference values for the axis or create new reference values. These values are to be used after the repair procedure is completed, for calibration of the robot.</p> <p>If no previous reference values exist, and no new reference values can be created, then reference calibration is not possible.</p>	<p>Follow the instructions given in the reference calibration routine on the FlexPendant to create reference values.</p> <p>Creating new values requires possibility to move the robot.</p> <p>Read more about reference calibration for Axis Calibration in Reference calibration routine on page 696.</p>
<p>If the robot is to be calibrated with fine calibration:</p> <p>Remove all external cable packages (DressPack) and tools from the robot.</p>	

Removing the motor

Use these procedures to remove the axis-6 motor.

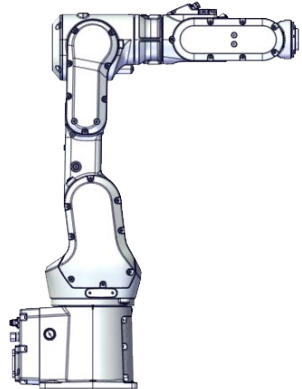
Preparations before removing the axis-6 motor

	Action	Note
1	Decide which calibration routine to use, and take actions accordingly prior to beginning the repair procedure.	
2	Jog all axes to zero position.	 <p>xx1800003288</p>
3	 <p>DANGER</p> <p>Turn off all:</p> <ul style="list-style-type: none"> • electric power supply • hydraulic pressure supply • air pressure supply <p>to the robot, before entering the safeguarded space.</p>	

Continues on next page



5 Repair

5.7.6 Replacing the axis-6 motor

Continued

	Action	Note
4	 CAUTION For robots with protection type Clean Room Always cut the paint with a knife and grind the paint edge when disassembling parts of the robot! See Cut the paint or surface on the robot before replacing parts on page 124 .	

Opening the process hub

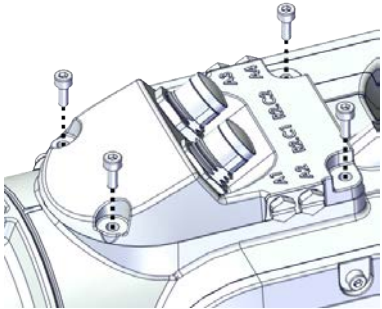
	Action	Note
1	 DANGER Make sure that all supplies for electrical power, hydraulic pressure, and air pressure are turned off.	
2	 CAUTION For robots with protection type Clean Room Always cut the paint with a knife and grind the paint edge when disassembling parts of the robot! See Cut the paint or surface on the robot before replacing parts on page 124 .	
3	Remove the screws and carefully open the cover.  CAUTION Be aware of the cabling that is attached to the cover!	 xx1800002944



Removing the wrist covers

	Action	Note
1	 DANGER Make sure that all supplies for electrical power, hydraulic pressure, and air pressure are turned off.	

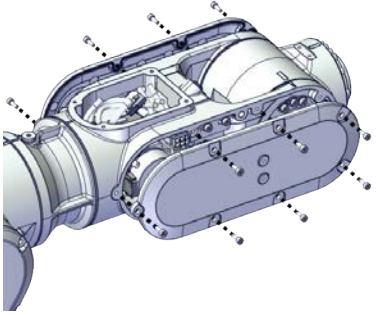
Continues on next page

	Action	Note
2	<p> CAUTION</p> <p>For robots with protection type Clean Room Always cut the paint with a knife and grind the paint edge when disassembling parts of the robot! See <i>Cut the paint or surface on the robot before replacing parts on page 124.</i></p>	
3	Remove the wrist covers from both sides.	 <p>xx1800002949</p>

Disconnecting the axis-6 motor connectors

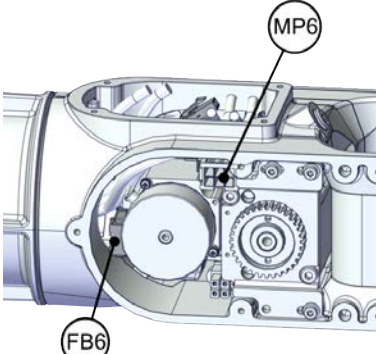
	Action	Note
1	<p> DANGER</p> <p>Make sure that all supplies for electrical power, hydraulic pressure, and air pressure are turned off.</p>	
2	<p> CAUTION</p> <p>For robots with protection type Clean Room Always cut the paint with a knife and grind the paint edge when disassembling parts of the robot! See <i>Cut the paint or surface on the robot before replacing parts on page 124.</i></p>	
3	<p>Disconnect the connectors.</p> <ul style="list-style-type: none"> • MP6 • FB6 	 <p>xx1800002994</p>



Continues on next page

5 Repair

5.7.6 Replacing the axis-6 motor

Continued

Removing the axis-6 motor

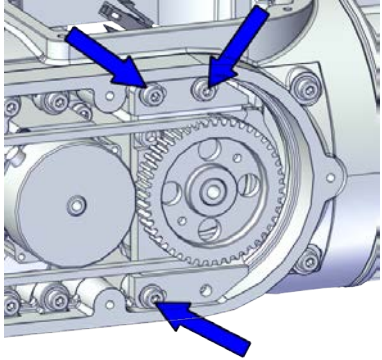
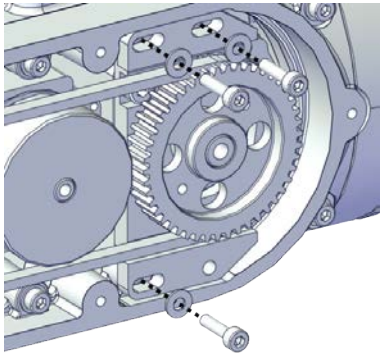
	Action	Note
1	 DANGER Make sure that all supplies for electrical power, hydraulic pressure, and air pressure are turned off.	
2	 CAUTION For robots with protection type Clean Room Always cut the paint with a knife and grind the paint edge when disassembling parts of the robot! See Cut the paint or surface on the robot before replacing parts on page 124 .	
3	 CAUTION Removing motors will release axes. This means the axes can fall down. Make sure axes are well supported before removing motors.	
4	Loosen the screws and move the motor slightly to slacken the timing belt.	 xx1800002995
5	Remove the screws and washers.	 xx1800002996
6	Carefully lift out the motor.	

Continues on next page

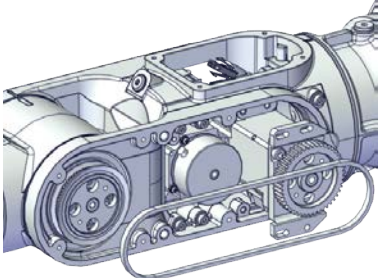
	Action	Note
7	Remove the timing belt from its groove on the motor.	 <p>xx1800002997</p>

Refitting the motor

Use these procedures to refit the axis-6 motor.

Refitting the axis-6 motor

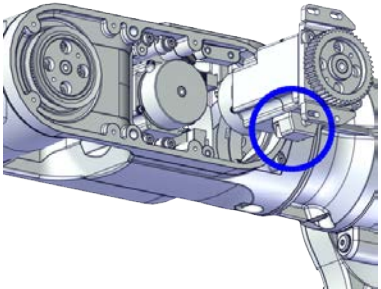

	Action	Note
1	For robots with protection type Clean Room: Clean the joints that have been opened and wipe the parts free from particles with spirit on a lint free.	
2	Check that: <ul style="list-style-type: none"> • all assembly surfaces are clean and without damages • the motor is clean and undamaged. 	
3	Orient the motor correctly and fit it into the lower arm.  Tip Leave the connectors FB5 and FB6 accessible from the process hub and the connectors MP5 and MP6 accessible from wrist side.	Motor orientation: orient the motor according to the figure below, in regard to the encircled motor connector.  <p>xx1800003023</p>

Continues on next page

5 Repair

5.7.6 Replacing the axis-6 motor

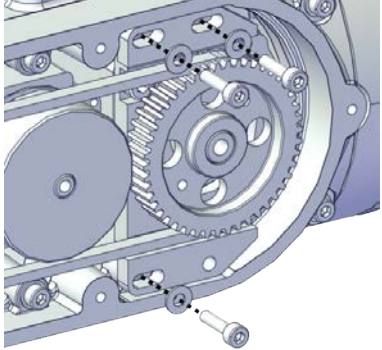
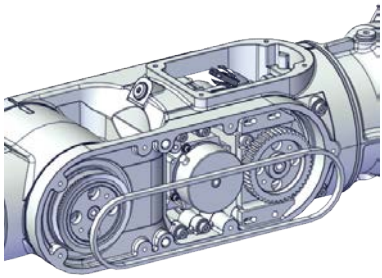
Continued

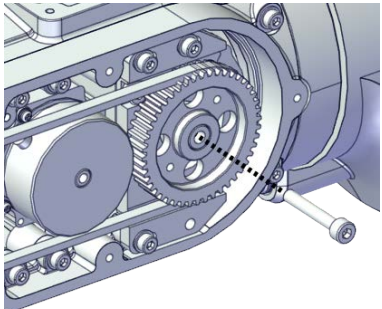
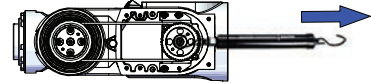
	Action	Note
4	<p>Refit the screws and washers.</p> <p> Note</p> <p>Do not tighten the screws yet.</p>	<p>Screw: M3x12 12.9 Lafre 2C2B/FC6.9 (3 pcs)</p>  <p>xx1800002996</p>
5	<p>Install the timing belt to the pulleys and verify that the belt runs correctly in the grooves of the pulleys.</p>	 <p>xx1800003024</p>
6	<p>Install an M4x25 or longer adjustment screw to the motor.</p> <p> Note</p> <p>Do not insert the entire screw to the hole.</p>	 <p>xx1900000007</p>
7	<p>Use a handheld dynamometer hooking to the screw and pull the dynamometer to reach the initial referenced force.</p>	<p>Initial referenced force for used belt: 8.96-9.8 N (for reference only) Initial referenced force for new belt: 12.8-14</p>  <p>xx1900000026</p>

Continues on next page

5.7.6 Replacing the axis-6 motor
Continued

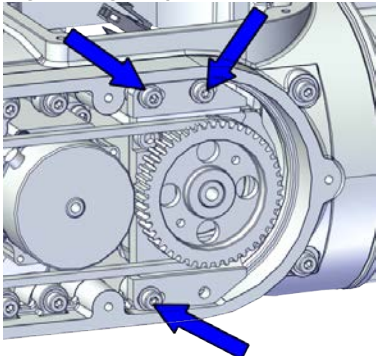
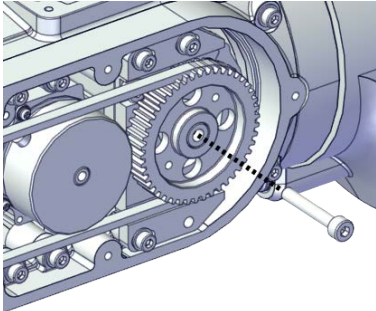
	Action	Note
8	Secure the motor with the screws.	Tightening torque: 1.4 Nm  xx1800002995
9	Use a sonic tension meter to measure the timing belt tension.	Used belt: 81.3-86.9 Hz New belt: 90-114 Hz (for reference only)
10	If the timing belt tension does not meet the requirement, loosen the motor screws and readjust.	
11	Remove the adjustment screw from the motor.	 xx1900000007

Reconnecting the axis-6 motor connectors



	Action	Note
1	For robots with protection type Clean Room: Clean the joints that have been opened and wipe the parts free from particles with spirit on a lint free.	

Continues on next page

5 Repair

5.7.6 Replacing the axis-6 motor

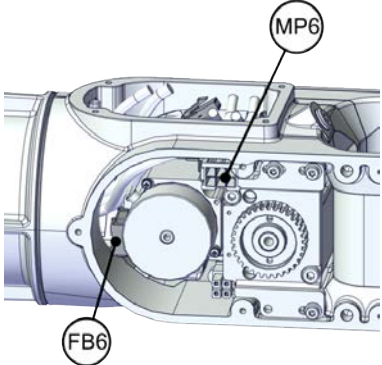
Continued

	Action	Note
2	<p>Reconnect the connectors.</p> <ul style="list-style-type: none"> • FB6 • MP6 <p> Tip</p> <p>See the number markings on the connectors for help to find the corresponding connector.</p>	 <p>xx1800002994</p>
3	<p>Route and secure the cabling with cable straps.</p> <p> CAUTION</p> <p>Correct cable routing is highly important. If the cables are routed and secured incorrectly the cables can be damaged.</p>	
4	<p>Insert the cabling and connectors into the wrist.</p>	

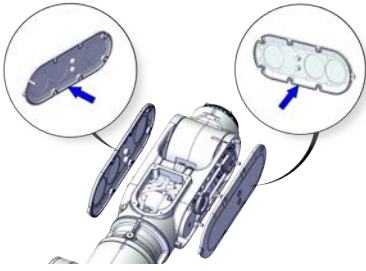

Refitting the wrist covers

	Action	Note
1	<p>For robots with protection type Clean Room: Clean the joints that have been opened and wipe the parts free from particles with spirit on a lint free.</p>	
2	<p>For robots with protection class IP67 (option 3350-670) For robots with protection type Clean Room (option 3351-4) Check the gaskets. Replace if damaged.</p>	<p>Gasket for wrist cover: 3HAC061959-009</p>  <p>xx1900002182</p>
3	<p>Apply grease to the cable package, cover all moving area of the package.</p>	
4	<p>Apply grease to the covers that have contacting area with the cable package.</p>	

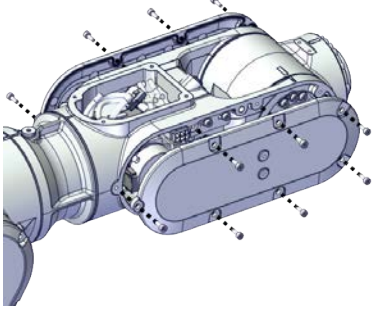
Continues on next page

	Action	Note
5	Refit the wrist covers.	<p>Screw: M3x8 12.9 Lafre 2C2B/FC6.9 (14 pcs) Tightening torque: 1.2 Nm</p>  <p>xx1800002949</p>

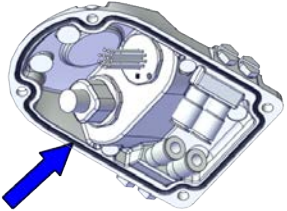
Refitting the process hub

	Action	Note
1	For robots with protection type Clean Room: Clean the joints that have been opened and wipe the parts free from particles with spirit on a lint free.	
2	<p>For robots with protection class IP67 (option 3350-670) For robots with protection type Clean Room (option 3351-4) Check the gasket. Replace if damaged.</p>	<p>Gasket for process hub: 3HAC065352-001</p>  <p>xx1900002187</p>
3	<p>Route and secure the cabling with cable straps.</p> <p> CAUTION</p> <p>Correct cable routing is highly important. If the cables are routed and secured incorrectly the cables can be damaged.</p>	

Continues on next page



5 Repair

5.7.6 Replacing the axis-6 motor

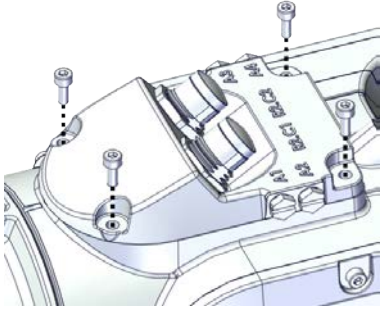
Continued

	Action	Note
4	Refit the cover.	<p>Screw: M3x8 12.9 Lafre 2C2B/FC6.9 (4 pcs) Tightening torque: 1.2 Nm</p>  <p>xx1800002944</p>

Concluding procedure

	Action	Note
1	<p>For robots with protection type Clean Room: Clean and paint the joints that have been opened. See Cut the paint or surface on the robot before replacing parts on page 124</p> <p> Note</p> <p>After all repair work, wipe the Clean Room robot free from particles with spirit on a lint free cloth.</p>	
2	Recalibrate the robot.	Calibration is detailed in section Calibration on page 685 .
3	<p> DANGER</p> <p>Make sure all safety requirements are met when performing the first test run. See Test run after installation, maintenance, or repair on page 91.</p>	

5.8 Gearboxes

5.8.1 Replacing the axis-1 gearbox

Location of the axis-1 gearbox

The axis-1 gearbox is located as shown in the figure.

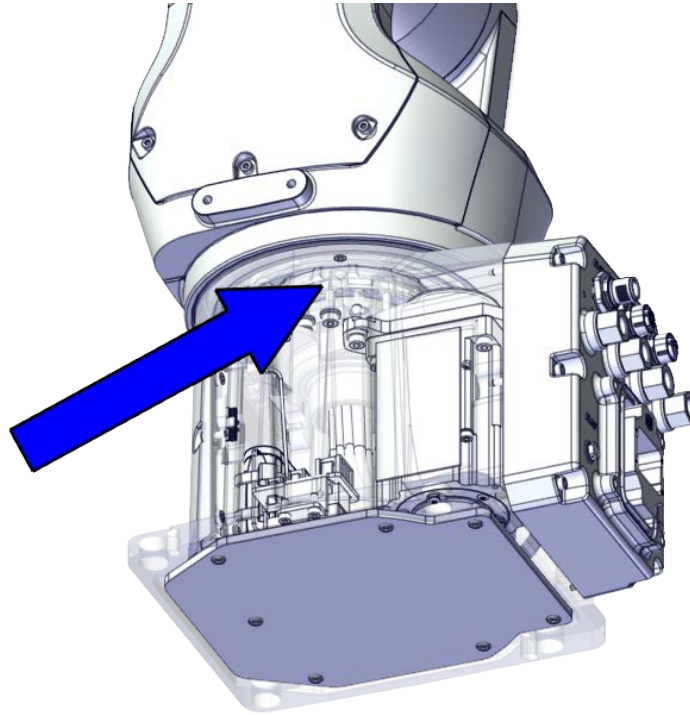

xx1800002478

Required spare parts



Note

The spare part numbers that are listed in the table can be out of date. See the latest spare parts of the IRB 1100 via myABB Business Portal, www.abb.com/myABB.

Spare part	Article number	Note
Lower cable harness, basic	3HAC075521-001	Used with protection classes IP40 and IP67.
Lower cable harness, basic, Clean Room	3HAC075514-001	Used with protection type Clean Room.
Lower cable harness (CP/CS and air hose, without Ethernet)	3HAC075522-001	Used with protection classes IP40 and IP67.
Lower cable harness, Clean Room (CP/CS and air hose, without Ethernet)	3HAC075515-001	Used with protection type Clean Room.

Continues on next page

5 Repair

5.8.1 Replacing the axis-1 gearbox

Continued

Spare part	Article number	Note
Lower cable harness (CP/CS and air hose, with Ethernet)	3HAC075523-001	Used with protection classes IP40 and IP67.
Lower cable harness, Clean Room (CP/CS and air hose, with Ethernet)	3HAC075581-001	Used with protection type Clean Room.
Gear unit with pulley, axis 1	3HAC069062-001	
Base	3HAC069048-001	
Base with sealing ring	3HAC074270-001	Used with protection class IP67.
Base with sealing ring, Clean Room	3HAC075488-001	Used with protection type Clean Room.
Axis-1 radial sealing	3HAC070148-005	Used with protection class IP67 and protection type Clean Room. Replace if damaged.
Motor with flange, axis 1	3HAC083589-001	
Timing belt, axis 1	3HAC061934-001	
Motor with flange, axis 2	3HAC083588-001	.
Timing belt, axis 2	3HAC061935-001	
Mechanical stop, axis 1	3HAC061947-001	Replace if damaged.
Base bottom cover	3HAC060463-001	Standard configuration, used for robots with rear connector interface.
Base rear cover	3HAC070312-001	Used for robots with bottom connector interface.
Base rear cover, Clean Room	3HAC075513-001	Used for robots with bottom connector interface. Used with protection type Clean Room.
Base adapter	3HAC070313-001	Used for robots with bottom connector interface.
Base adapter, Clean Room	3HAC075793-001	Used for robots with bottom connector interface. Used with protection type Clean Room.
Swing cover	3HAC069051-001	
Swing cover, Clean Room	3HAC075498-001	Used with protection type Clean Room.
Swing support cover	3HAC069052-001	
Swing support cover, Clean Room	3HAC075500-001	Used with protection type Clean Room.
Gasket for base bottom	3HAC065345-001	Used with protection class IP67 and protection type Clean Room. Replace if damaged.
Gasket for base rear	3HAC065350-001	Used with protection class IP67 and protection type Clean Room. Replace if damaged.

Continues on next page

Spare part	Article number	Note
Gasket for swing cover	3HAC061959-003	Used with protection class IP67 and protection type Clean Room. Replace if damaged.
Gasket for swing support cover	3HAC065317-001	Used with protection class IP67 and protection type Clean Room. Replace if damaged.
Gasket for process hub	3HAC065352-001	Used with protection class IP67 and protection type Clean Room. Replace if damaged.
Gasket for SMB cover	3HAC065344-001	Used with protection class IP67 and protection type Clean Room. Replace if damaged.
Cooling pad for axis-1 and -2 motors	3HAC071020-001	Cooling pads are wear parts. One cooling pad sheet contains 6 pieces of small pad. Replace if damaged with one piece each time.
Washer	3HAC063985-001	9x4.3x1, Steel

Required tools and equipment

Equipment	Article number	Note
Standard toolkit	-	Content is defined in section Standard toolkit on page 733 .
Calibration tool box, Axis Calibration	3HAC074119-001	Delivered as a set of calibration tools. Required if Axis Calibration is the valid calibration method for the robot. The tool box also includes a unique calibration pin for IRB 1100 to be fitted to the tool flange during calibration of axis 6.
24 VDC power supply	-	Used to release the motor brakes.
Dynamometer	-	Used for measuring the timing belt tension.

Required consumables

Consumable	Article number	Note
Cable straps	-	
Grease	3HAC029132-001	FM 222
Locking liquid	-	Loctite 2400 (or equivalent Loctite 243)

Continues on next page

5 Repair

5.8.1 Replacing the axis-1 gearbox

Continued

Deciding calibration routine

Decide which calibration routine to be used, based on the information in the table. Depending on which routine is chosen, action might be required prior to beginning the repair work of the robot, see the table.

	Action	Note
1	<p>Decide which calibration routine to use for calibrating the robot.</p> <ul style="list-style-type: none"> Reference calibration. External cable packages (DressPack) and tools can stay fitted on the robot. Fine calibration. All external cable packages (DressPack) and tools must be removed from the robot. 	<p> Note</p> <p>Calibrating axis 6 always requires tools to be removed from the mounting flange (also for reference calibration) since the mounting flange is used for installation of the calibration tool.</p>
	<p>If the robot is to be calibrated with reference calibration:</p> <p>Find previous reference values for the axis or create new reference values. These values are to be used after the repair procedure is completed, for calibration of the robot.</p> <p>If no previous reference values exist, and no new reference values can be created, then reference calibration is not possible.</p>	<p>Follow the instructions given in the reference calibration routine on the FlexPendant to create reference values.</p> <p>Creating new values requires possibility to move the robot.</p> <p>Read more about reference calibration for Axis Calibration in Reference calibration routine on page 696.</p>
	<p>If the robot is to be calibrated with fine calibration:</p> <p>Remove all external cable packages (DressPack) and tools from the robot.</p>	



Removing the gearbox

Use these procedures to remove the axis-1 gearbox.

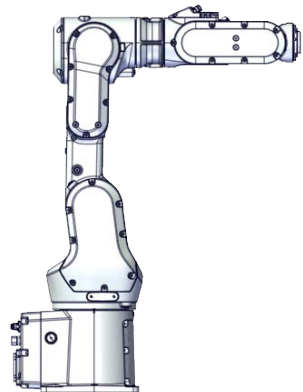

Preparations before removing the axis-1 gearbox

	Action	Note
1	Decide which calibration routine to use, and take actions accordingly prior to beginning the repair procedure.	
2	Jog all axes to zero position.	 <p>xx1800003288</p>

Continues on next page

	Action	Note
3	 DANGER Turn off all: <ul style="list-style-type: none"> • electric power supply • hydraulic pressure supply • air pressure supply to the robot, before entering the safeguarded space.	
4	 CAUTION For robots with protection type Clean Room Always cut the paint with a knife and grind the paint edge when disassembling parts of the robot! See Cut the paint or surface on the robot before replacing parts on page 124 .	

Removing the axis-2 motor





	Action	Note
1	 DANGER Make sure that all supplies for electrical power, hydraulic pressure, and air pressure are turned off.	
2	 CAUTION For robots with protection type Clean Room Always cut the paint with a knife and grind the paint edge when disassembling parts of the robot! See Cut the paint or surface on the robot before replacing parts on page 124 .	
3	 CAUTION Removing motors will release axes. This means the axes can fall down. Make sure axes are well supported before removing motors.	

Continues on next page

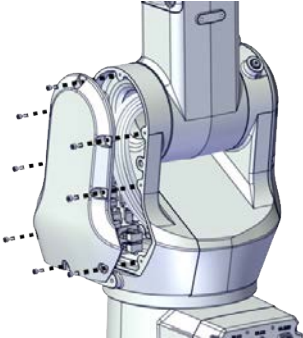

5 Repair

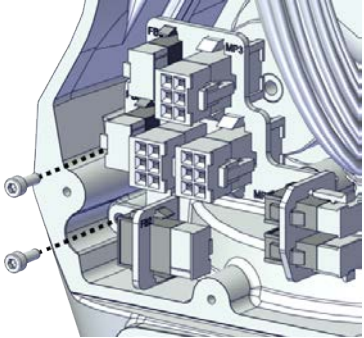
5.8.1 Replacing the axis-1 gearbox

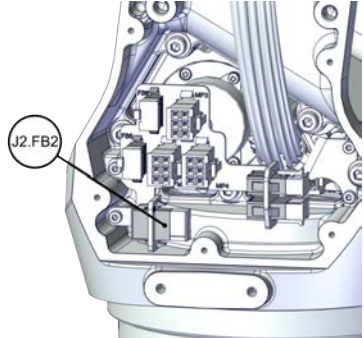
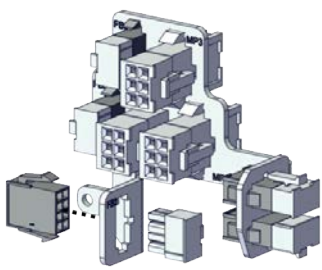
Continued

	Action	Note
4	Remove the swing support cover.	 xx1800002488
5	Remove the connector plate.  CAUTION Be aware of the cablings that are attached to the connector plate! The connector plate cannot be removed completely until the connectors are removed from the plate.	 xx1800002489
6	Disconnect the connector. • J2.FB2  Tip Take photos of the connector and cable position before disconnecting them, to have as a reference when reconnecting.	 xx1800002490
7	Snap loose and remove the female head of the connector from the connector plate.	 xx1800002491

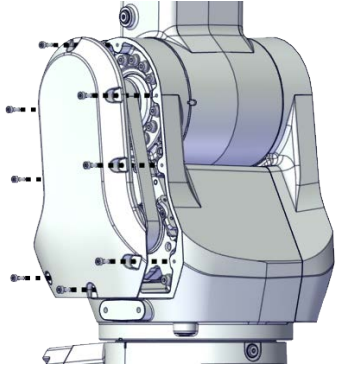
Continues on next page

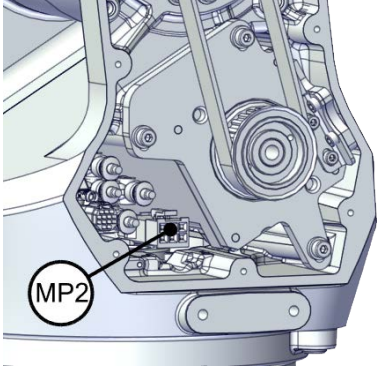
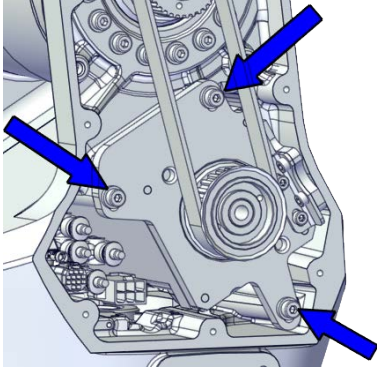
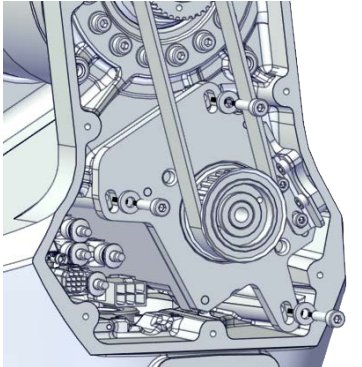

	Action	Note
8	Remove the swing cover.	 <p>xx1800002492</p>
9	Disconnect the connector. <ul style="list-style-type: none"> • MP2  Tip Take photos of the connector and cable position before disconnecting them, to have as a reference when reconnecting.	 <p>xx1800002495</p>
10	Loosen the screws and move the motor slightly to slacken the timing belt.	 <p>xx1800002493</p>
11	Remove the screws and washers.	 <p>xx1800002494</p>

Continues on next page



5 Repair

5.8.1 Replacing the axis-1 gearbox

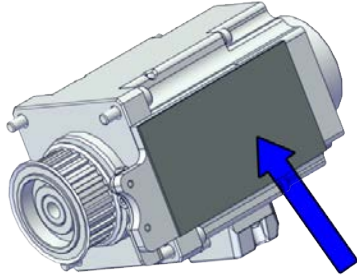
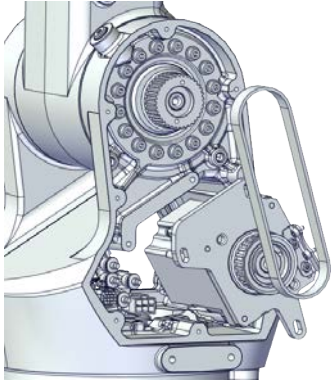
Continued

	Action	Note
12	<p>Carefully lift out the motor.</p> <p> CAUTION</p> <p>A cooling pad is attached to the motor, which may stick to the casting. Always use a plastic sheet with caution to remove the pad from the casting. Pay attention not to scratch the casting or damage the pad.</p> <p> CAUTION</p> <p>Be aware of the motor cabling. The motor cannot be removed completely until the connector is disconnected, as shown in following step.</p>	<p>Cooling pad location</p>  <p>xx1800003603</p>
13	<p>Remove the timing belt from its groove on the motor.</p>	 <p>xx1800002496</p>



Loosening the cable package from axis-1 gearbox

	Action	Note
1	<p> DANGER</p> <p>Make sure that all supplies for electrical power, hydraulic pressure, and air pressure are turned off.</p>	
2	<p> CAUTION</p> <p>For robots with protection type Clean Room</p> <p>Always cut the paint with a knife and grind the paint edge when disassembling parts of the robot! See Cut the paint or surface on the robot before replacing parts on page 124.</p>	

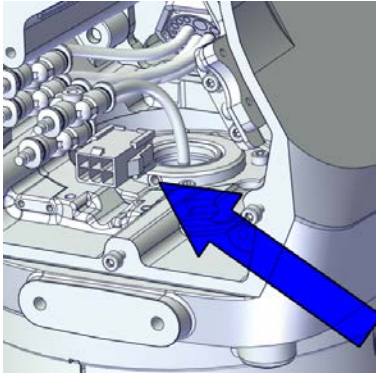
Continues on next page

	Action	Note
3	Access the cable package locking screw on the axis-1 gearbox from the swing and then loosen the locking screw.	 <p>xx1800003032</p>
4	Remove the locking screw.	

Disconnecting the connectors at the division point

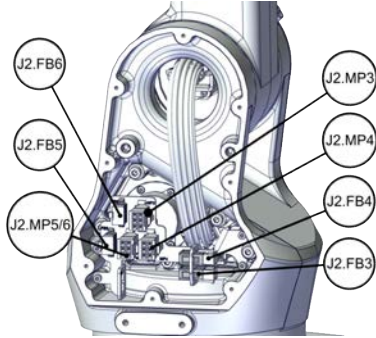
	Action	Note
1	 <p>DANGER</p> <p>Make sure that all supplies for electrical power, hydraulic pressure, and air pressure are turned off.</p>	
2	 <p>CAUTION</p> <p>For robots with protection type Clean Room Always cut the paint with a knife and grind the paint edge when disassembling parts of the robot! See Cut the paint or surface on the robot before replacing parts on page 124.</p>	
3	<p>Disconnect the connectors.</p> <ul style="list-style-type: none"> • J2.FB3,4,5,6 • J2.MP3,4,5/6  <p>Tip</p> <p>Take photos of the connector and cable position before disconnecting them, to have as a reference when reconnecting.</p>	 <p>xx1800002497</p>

Continues on next page



5 Repair

5.8.1 Replacing the axis-1 gearbox

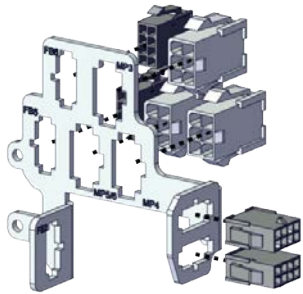
Continued

	Action	Note
4	Snap loose and remove the female head of the connectors from the connector plate.	 <p>xx1800002498</p>

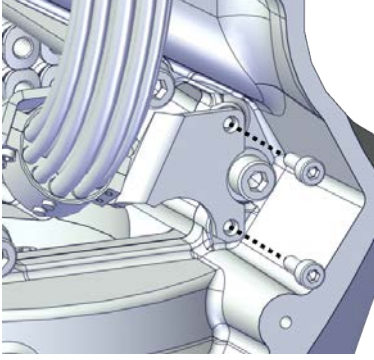

Separating the cable package from the swing

	Action	Note
1	 DANGER Make sure that all supplies for electrical power, hydraulic pressure, and air pressure are turned off.	
2	 CAUTION For robots with protection type Clean Room Always cut the paint with a knife and grind the paint edge when disassembling parts of the robot! See Cut the paint or surface on the robot before replacing parts on page 124.	
3	Remove the cable bracket.	 <p>xx1800002499</p>

Disconnecting the air hoses, CP/CS cabling and Ethernet cabling (if equipped)

	Action	Note
1	 DANGER Make sure that all supplies for electrical power, hydraulic pressure, and air pressure are turned off.	

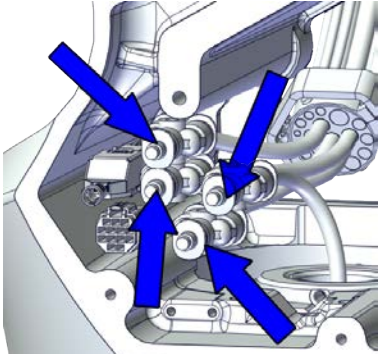
Continues on next page

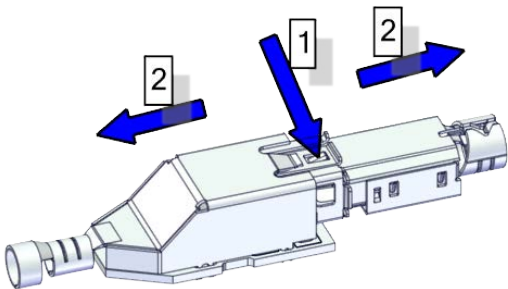
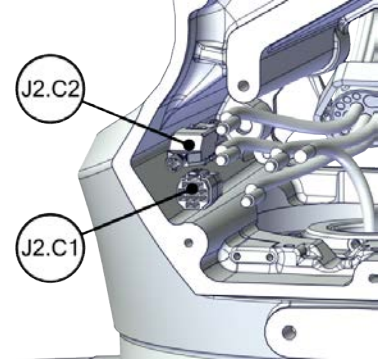
	Action	Note
2	<p> CAUTION</p> <p>For robots with protection type Clean Room Always cut the paint with a knife and grind the paint edge when disassembling parts of the robot! See <i>Cut the paint or surface on the robot before replacing parts on page 124.</i></p>	
3	<p>Disconnect the air hoses from the Y-shaped connectors.</p>	 <p>xx1800002500</p>
4	<p>Disconnect the connectors.</p> <ul style="list-style-type: none"> • J2.C1 • J2.C2 <p> Tip</p> <p>Take photos of the connector and cable position before disconnecting them, to have as a reference when reconnecting.</p> <p> Tip</p> <p>The connector clip has to be pressed (1) and pushed forward (2) to separate the J2.C2 (for Ethernet cabling).</p>  <p>xx1800002943</p>	 <p>xx1800002501</p>





Continues on next page

5 Repair

5.8.1 Replacing the axis-1 gearbox

Continued



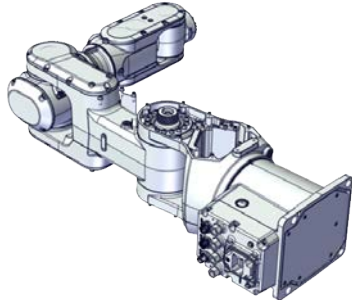



Putting the robot on its side

	Action	Note
1	 DANGER Make sure that all supplies for electrical power, hydraulic pressure, and air pressure are turned off.	
2	 CAUTION For robots with protection type Clean Room Always cut the paint with a knife and grind the paint edge when disassembling parts of the robot! See Cut the paint or surface on the robot before replacing parts on page 124 .	
3	 CAUTION The IRB 1100 robot weighs 21.1 kg and can be lifted by one person.	
4	 WARNING The robot is likely to be mechanically unstable if not secured to the foundation.	
5	Loosen the robot from the foundation by removing the foundation attachment screws and put the robot on its side.	 xx1800003033

Disconnecting the SMB connectors

	Action	Note
1	 DANGER Make sure that all supplies for electrical power, hydraulic pressure, and air pressure are turned off.	

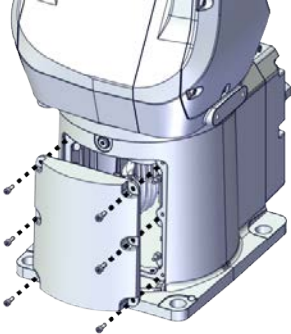
Continues on next page

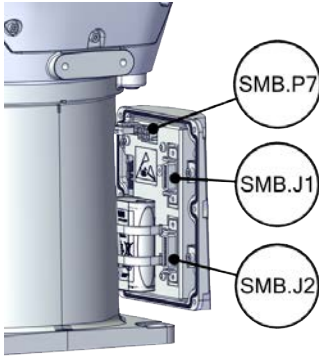
	Action	Note
2	 ELECTROSTATIC DISCHARGE (ESD) The unit is sensitive to ESD. Before handling the unit read the safety information in section The unit is sensitive to ESD on page 49 .	
3	 CAUTION For robots with protection type Clean Room Always cut the paint with a knife and grind the paint edge when disassembling parts of the robot! See Cut the paint or surface on the robot before replacing parts on page 124 .	
4	Remove the SMB cover attachment screws and carefully open the cover.  CAUTION Clean cover from metal residues before opening. Metal residues can cause shortage on the boards which can result in hazardous failures.  CAUTION There are cabling attached to the cover. The cover cannot be removed completely until the connectors are removed.	 xx1800002467
5	Disconnect the connectors. <ul style="list-style-type: none"> • SMB.P7 • SMB.J1 • SMB.J2  Tip Take photos of the connector and cable position before disconnecting them, to have as a reference when reconnecting.	 xx1800002468
6	Remove the SMB cover completely from the base.	

Opening the connector interface plate



	Action	Note
1	 DANGER Make sure that all supplies for electrical power, hydraulic pressure, and air pressure are turned off.	

Continues on next page

5 Repair

5.8.1 Replacing the axis-1 gearbox

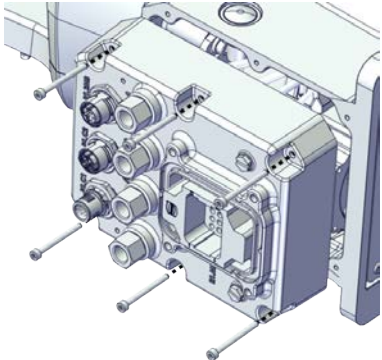
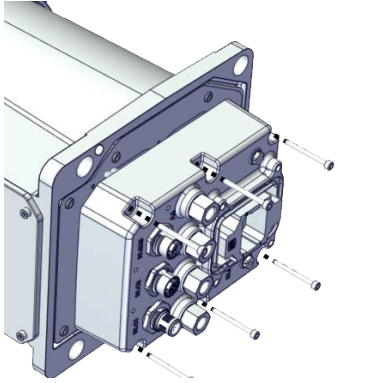
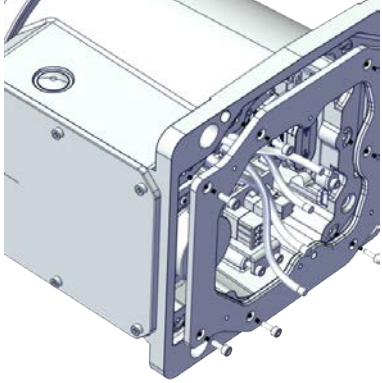

Continued

	Action	Note
2	<p> CAUTION</p> <p>For robots with protection type Clean Room Always cut the paint with a knife and grind the paint edge when disassembling parts of the robot! See <i>Cut the paint or surface on the robot before replacing parts on page 124.</i></p>	
3	<p>Remove the connector interface plate attachment screws and carefully open the plate.</p> <p> CAUTION</p> <p>There are cabling attached to the cover. The cover cannot be removed completely until the connectors are removed.</p>	<p>Valid for cabling with rear interface</p>  <p>xx1800003034</p> <p>Valid for cabling with bottom interface (option 3309-1)</p>  <p>xx1800003055</p>
4	<p>Valid for cabling with bottom interface (option 3309-1)</p> <p>Remove the base adapter.</p>	 <p>xx1800003056</p>

Continues on next page

Removing the brake release button

Notice that the procedure differs depending on if the connector interface is located either at the rear or at the bottom of the base.

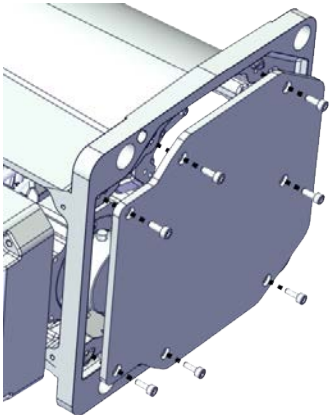
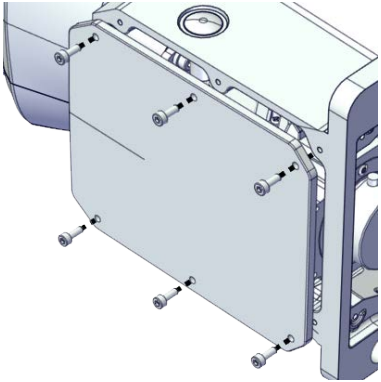

	Action	Note
1	 <p>DANGER</p> <p>Make sure that all supplies for electrical power, hydraulic pressure, and air pressure are turned off.</p>	
2	 <p>CAUTION</p> <p>For robots with protection type Clean Room Always cut the paint with a knife and grind the paint edge when disassembling parts of the robot! See Cut the paint or surface on the robot before replacing parts on page 124.</p>	
3	<p>Valid for cabling with rear interface Remove the base bottom cover.</p>	 <p>xx1800003035</p>
4	<p>Valid for cabling with bottom interface (option 3309-1) Remove the base rear cover.</p>	 <p>xx1800003057</p>

Continues on next page

5 Repair

5.8.1 Replacing the axis-1 gearbox

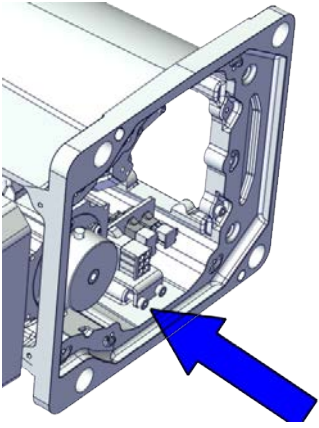
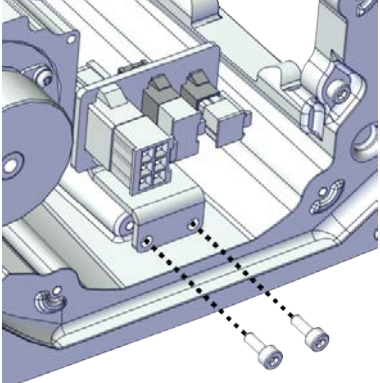

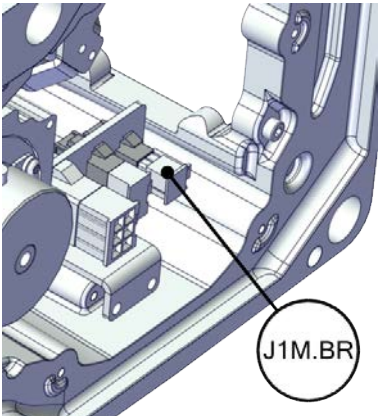
Continued

	Action	Note
5	Disconnect the earth cable.	 xx1800003036
6	Remove the connector plate.	 xx1800003037
7	Disconnect the connector. <ul style="list-style-type: none">• J1M.BR  Tip Take photos of the connector and cable position before disconnecting them, to have as a reference when reconnecting.	 xx1800003038

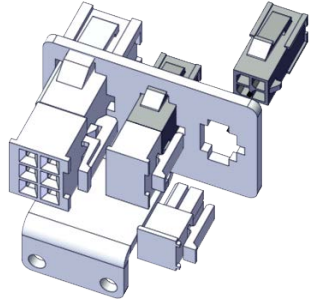
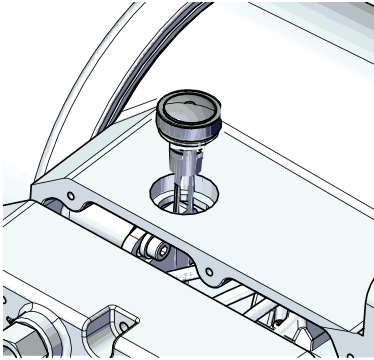
Continues on next page

	Action	Note
8	Remove the female header of the J1M.BR connector from the connector plate.	 <p>xx1800003039</p>
9	Remove the brake release button from the base using the tool.	<p>brake release button assembly tool, included in the special toolkit 3HAC071022-001</p>  <p>xx1800003040</p>

Disconnecting axis-1 motor connectors

	Action	Note
1	 <p>DANGER</p> <p>Make sure that all supplies for electrical power, hydraulic pressure, and air pressure are turned off.</p>	
2	 <p>CAUTION</p> <p>For robots with protection type Clean Room Always cut the paint with a knife and grind the paint edge when disassembling parts of the robot! See Cut the paint or surface on the robot before replacing parts on page 124.</p>	

Continues on next page



5 Repair

5.8.1 Replacing the axis-1 gearbox

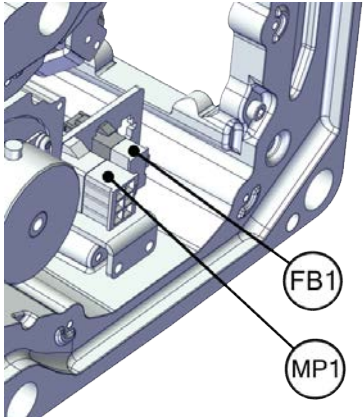
Continued

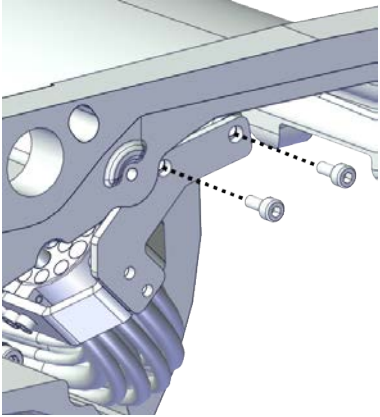

	Action	Note
3	<p>Disconnect the connectors.</p> <ul style="list-style-type: none"> • FB1 • MP1 <p> Tip</p> <p>Take photos of the connector and cable position before disconnecting them, to have as a reference when reconnecting.</p>	 <p>xx1800003041</p>

Separating the cable package from the base



	Action	Note
1	<p> DANGER</p> <p>Make sure that all supplies for electrical power, hydraulic pressure, and air pressure are turned off.</p>	
2	<p> CAUTION</p> <p>For robots with protection type Clean Room</p> <p>Always cut the paint with a knife and grind the paint edge when disassembling parts of the robot! See Cut the paint or surface on the robot before replacing parts on page 124.</p>	
3	<p>Remove the cable bracket.</p>	 <p>xx1800003042</p>

Continues on next page

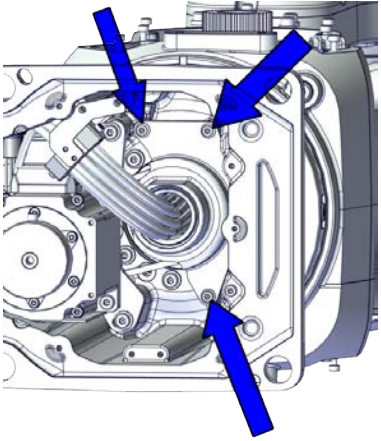
Separating the cable package from the axis-1 gearbox

	Action	Note
1	 DANGER Make sure that all supplies for electrical power, hydraulic pressure, and air pressure are turned off.	
2	 CAUTION For robots with protection type Clean Room Always cut the paint with a knife and grind the paint edge when disassembling parts of the robot! See <i>Cut the paint or surface on the robot before replacing parts on page 124.</i>	
3	Remove the pulley cover.	 <p>xx1800003043</p>

Pulling out the cable package

	Action	Note
1	 DANGER Make sure that all supplies for electrical power, hydraulic pressure, and air pressure are turned off.	
2	 CAUTION For robots with protection type Clean Room Always cut the paint with a knife and grind the paint edge when disassembling parts of the robot! See <i>Cut the paint or surface on the robot before replacing parts on page 124.</i>	

Continues on next page

5 Repair

5.8.1 Replacing the axis-1 gearbox

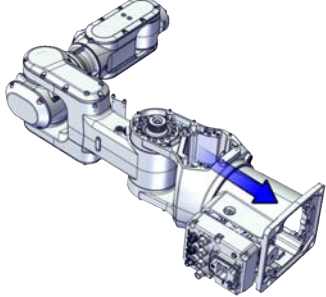
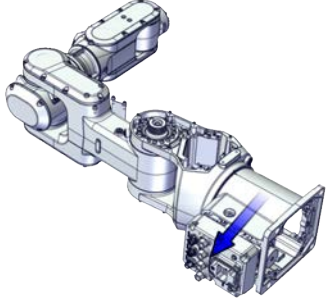
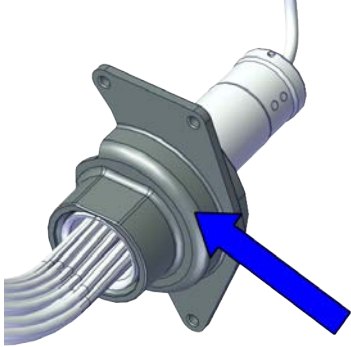

Continued

	Action	Note
3	Pull out the lower cable package from the axis-1 gearbox.	 xx1800003044
4	Pull out the lower cable package from the base.	 xx1800003045
5	Remove the pulley cover from the lower cable package.	 xx1800003046

Removing the axis-1 motor

	Action	Note
1	 DANGER Make sure that all supplies for electrical power, hydraulic pressure, and air pressure are turned off.	

Continues on next page

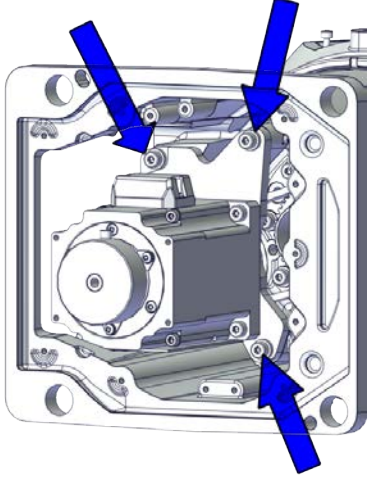
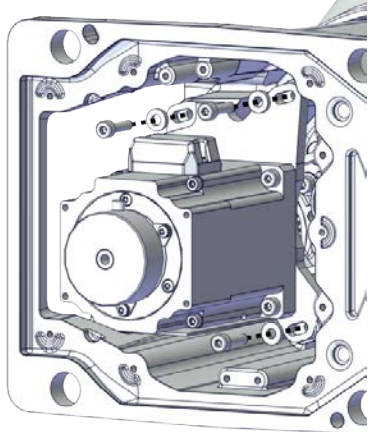
	Action	Note
2	<p> CAUTION</p> <p>For robots with protection type Clean Room Always cut the paint with a knife and grind the paint edge when disassembling parts of the robot! See <i>Cut the paint or surface on the robot before replacing parts on page 124.</i></p>	
3	<p> CAUTION</p> <p>Removing motors will release axes. This means the axes can fall down. Make sure axes are well supported before removing motors.</p>	
4	<p>Loosen the screws and move the motor slightly to slacken the timing belt.</p>	 <p>xx1800003064</p>
5	<p>Remove the screws and washers.</p>	 <p>xx1800003065</p>

Continues on next page



5 Repair

5.8.1 Replacing the axis-1 gearbox

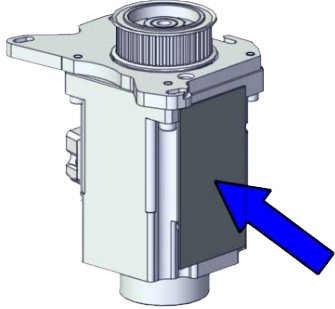
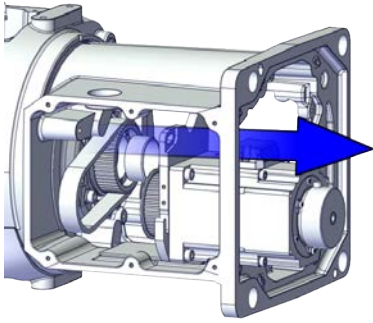
Continued

	Action	Note
6	<p>Carefully lift out the motor.</p> <p> CAUTION</p> <p>A cooling pad is attached to the motor, which may stick to the casting. Always use a plastic sheet with caution to remove the pad from the casting. Pay attention not to scratch the casting or damage the pad.</p>	<p>Cooling pad location</p>  <p>xx1800003602</p>
7	<p>Remove the timing belt from its groove on the motor.</p>	 <p>xx1800003066</p>



Removing the axis-1 timing belt

	Action	Note
1	<p> DANGER</p> <p>Make sure that all supplies for electrical power, hydraulic pressure, and air pressure are turned off.</p>	
2	<p> CAUTION</p> <p>For robots with protection type Clean Room</p> <p>Always cut the paint with a knife and grind the paint edge when disassembling parts of the robot! See Cut the paint or surface on the robot before replacing parts on page 124.</p>	
3	<p> CAUTION</p> <p>Loosening timing belts will release axes. This means the axes can fall down.</p> <p>Make sure axes are well supported before loosening timing belts.</p>	

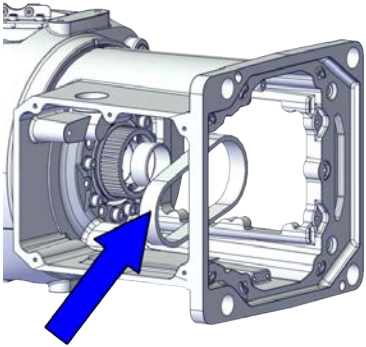
Continues on next page

	Action	Note
4	Remove the timing belt from its groove on the gearbox.	 <p>xx1800003067</p>

Separating the base from the swing



	Action	Note
1	 <p>DANGER</p> <p>Make sure that all supplies for electrical power, hydraulic pressure, and air pressure are turned off.</p>	
2	 <p>CAUTION</p> <p>For robots with protection type Clean Room Always cut the paint with a knife and grind the paint edge when disassembling parts of the robot! See Cut the paint or surface on the robot before replacing parts on page 124.</p>	

Continues on next page

5 Repair

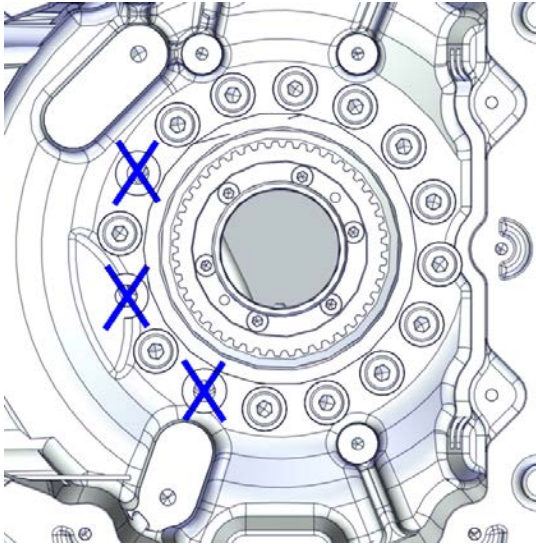
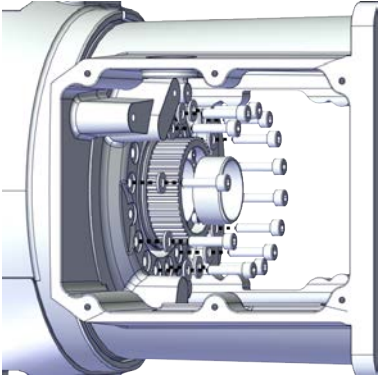

5.8.1 Replacing the axis-1 gearbox

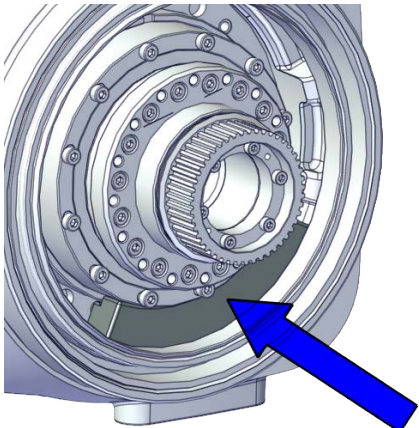
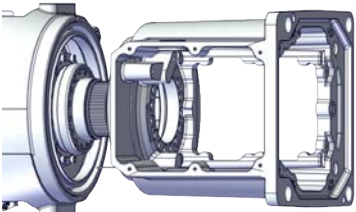
Continued

	Action	Note
3	<p>Remove the screws and washers.</p> <p> Tip</p> <p>Three screw holes have no screws fitted in. Take photos of the screw and washer position before removing them, to have as a reference when refitting.</p>  <p>xx1800003068</p>	 <p>xx1800003069</p>
4	<p>Separate the base from the swing.</p> <p> CAUTION</p> <p>The axis-1 mechanical stop is accessible now. Put it aside for later refitting.</p>  <p>xx1800003071</p>	 <p>xx1800003070</p>

Continues on next page

Removing the axis-1 gearbox

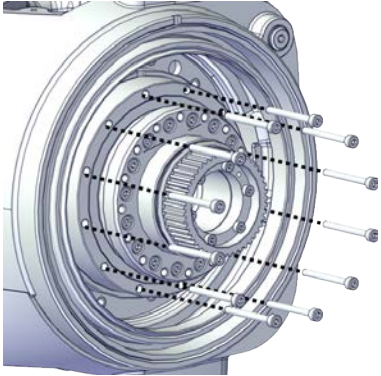
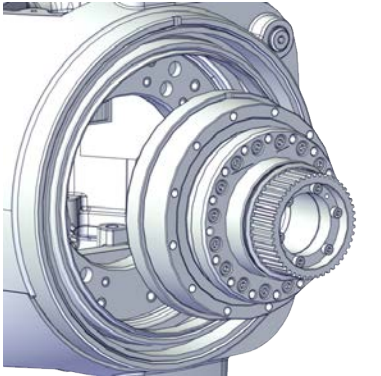
	Action	Note
1	 <p>DANGER</p> <p>Make sure that all supplies for electrical power, hydraulic pressure, and air pressure are turned off.</p>	
2	 <p>CAUTION</p> <p>For robots with protection type Clean Room Always cut the paint with a knife and grind the paint edge when disassembling parts of the robot! See <i>Cut the paint or surface on the robot before replacing parts on page 124.</i></p>	
3	 <p>CAUTION</p> <p>Removing gearboxes will release axes. This means the axes can fall down. Make sure axes are well supported before removing gearboxes.</p>	
4	<p>Remove the screws.</p>	 <p>xx1800003073</p>
5	<p>Pull out the gearbox.</p>	 <p>xx1800003074</p>

Continues on next page

5 Repair

5.8.1 Replacing the axis-1 gearbox

Continued

Refitting the gearbox

Use these procedures to refit the axis-1 gearbox.

Checking the radial sealing on the swing (IP67 and Clean Room)

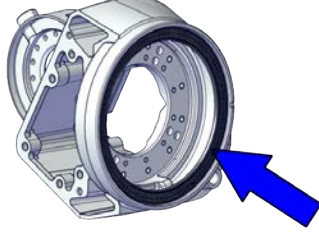
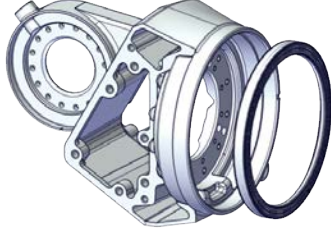
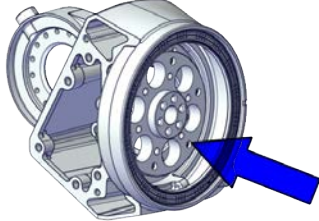
	Action	Note
1	For robots with protection type Clean Room: Clean the joints that have been opened and wipe the parts free from particles with spirit on a lint free.	
2	Check the radial sealing on the swing. Replace if damaged, as described below. In order to replace the radial sealing, both the axis-1 mechanical stop and the axis-1 gearbox must be removed from the swing, if not already removed.	 xx1900002200
3	Apply a little grease to the new sealing when replacing the radial sealing and wipe clean after the replacement.	Grease: 3HAC029132-001
4	Place the new sealing in its groove in the swing.	 xx1900002154
5	Place the small circular plate of the radial sealing fitting tool in and against the swing.	Axis-1 radial sealing assembly tool, included in the radial sealing assembly tool set 3HAC074609-001.  xx1900002155

Continues on next page

5.8.1 Replacing the axis-1 gearbox

Continued

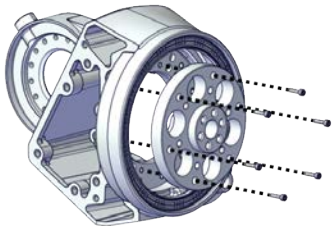
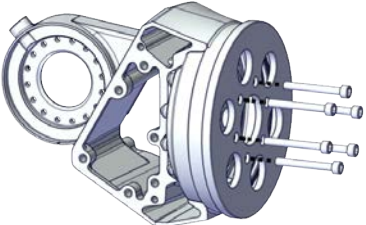
	Action	Note
6	Secure the small circular plate with screws.	 xx2000000305
7	Place the large circular plate of the radial sealing fitting tool against the radial sealing and fix with six M6x50 screws.	 xx1900002156
8	Screw the screws, little by little and evenly, to press the sealing into place.	
9	Remove the assembly tool.	
10	Check that the sealing is undamaged and properly fitted.	

Refitting the axis-1 gearbox

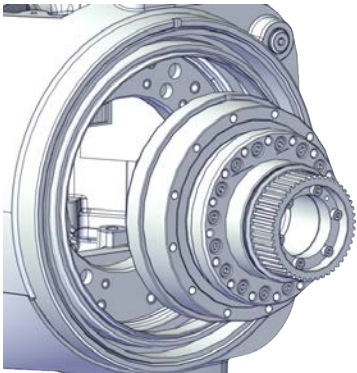
	Action	Note
1	For robots with protection type Clean Room: Clean the joints that have been opened and wipe the parts free from particles with spirit on a lint free.	
2	Refit the axis-1 gearbox. Make sure the locking screw hole on the gearbox is aligned with the notch on the swing casting.	 xx1800003074

Continues on next page

5 Repair

5.8.1 Replacing the axis-1 gearbox

Continued

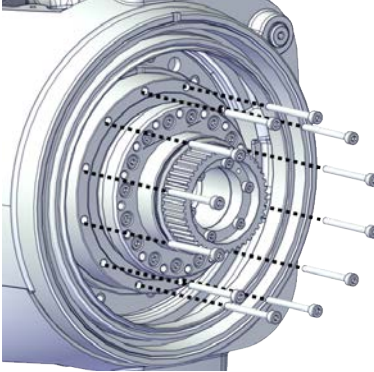
	Action	Note
3	Secure with screws.	<p>Screw: M3x30 12.9 Lafre 2C2B/FC6.9 (12 pcs) Tightening torque: 1.6 Nm</p>  <p>xx1800003073</p>

Placing the axis-1 mechanical stop

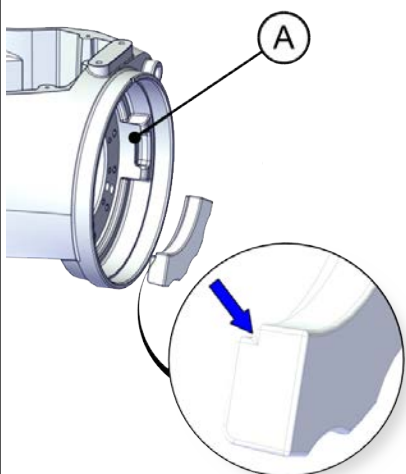
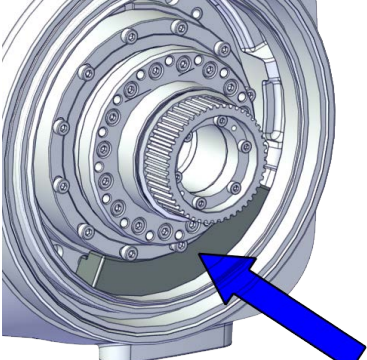
	Action	Note
1	For robots with protection type Clean Room: Clean the joints that have been opened and wipe the parts free from particles with spirit on a lint free.	
2	Check the axis-1 mechanical stop. Replace if damaged.	Mechanical stop, axis 1: 3HAC061947-001
3	<p>Put the axis-1 mechanical stop in place in the swing.</p> <p> Note</p> <p>The mechanical stop can be placed in any place except the block (A) on the swing. Make sure the mechanical stop step pointed in the figure is facing the swing when putting.</p>  <p>xx1800003619</p>	 <p>xx1800003071</p>

Continues on next page

Refitting the base to the swing

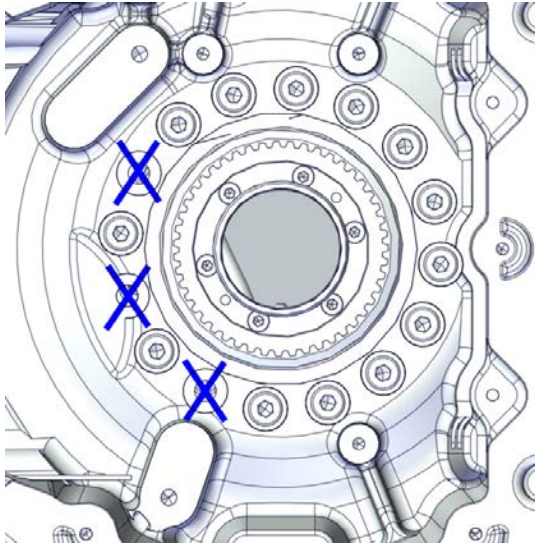
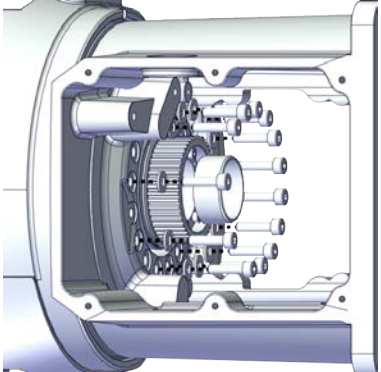
	Action	Note
1	For robots with protection type Clean Room: Clean the joints that have been opened and wipe the parts free from particles with spirit on a lint free.	
2	Refit the base to the swing.  Note Pay attention to the screw and washer location. 	Screw: M4x16 12.9 Lafre 2C2B/FC6.9 (13 pcs) Tightening torque: 4.4 Nm  xx1800003069

Refitting the brake release button

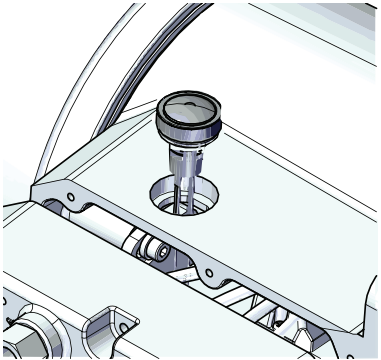
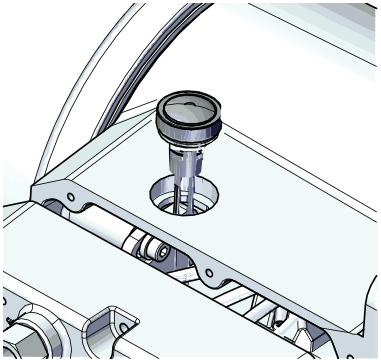
	Action	Note
1	For robots with protection type Clean Room: Clean the joints that have been opened and wipe the parts free from particles with spirit on a lint free.	
2	Refit the brake release button.  Note Do not reconnect the connector yet. Do not tighten the button yet. 	brake release button assembly tool, included in the special toolkit 3HAC071022-001  xx1800003040

Continues on next page

5 Repair

5.8.1 Replacing the axis-1 gearbox

Continued

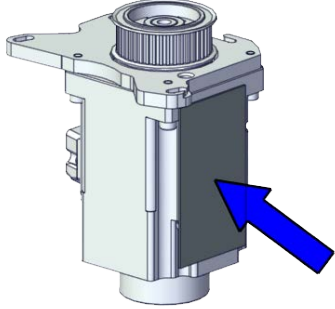
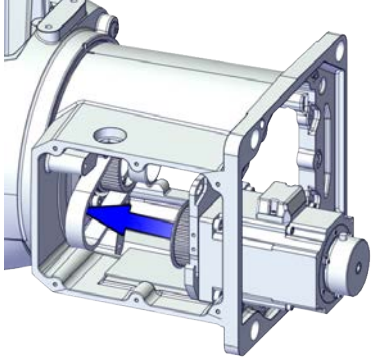

Refitting the axis-1 motor

	Action	Note
1	For robots with protection type Clean Room: Clean the joints that have been opened and wipe the parts free from particles with spirit on a lint free.	
2	Check that: <ul style="list-style-type: none">• all assembly surfaces are clean and without damages• the motor is clean and undamaged.	
3	Check the cooling pad. Replace if damaged.	Cooling pad for axis-1 and -2 motors: 3HAC071020-001  xx1800003602
4	Install the timing belt to the motor pulley and verify that the belt runs correctly in the groove of the pulley.	 xx1800003085

Continues on next page

5.8.1 Replacing the axis-1 gearbox

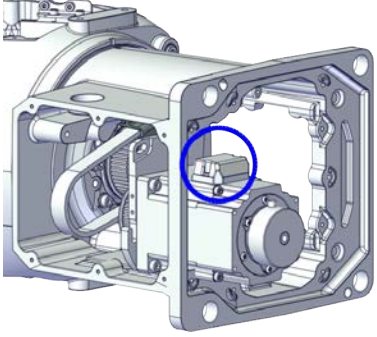
Continued

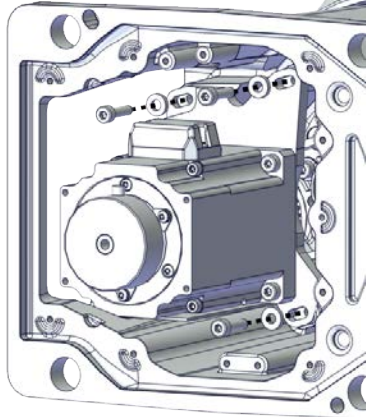
	Action	Note
5	<p>Orient the motor correctly and fit it into the base. At the same time, install the timing belt to the gearbox pulley and verify that the belt runs correctly in the groove of the pulley.</p>	<p>Motor orientation: orient the motor according to the figure below, in regard to the encircled motor connector.</p>  <p>xx1800003072</p>
6	<p>Refit the screws and washers.</p> <p> Note</p> <p>Do not tighten the screws yet.</p>	<p>Screw: M4x16 12.9 Lafre 2C2B/FC6.9 (3 pcs) Washer, 3HAC063985-001 (3 pcs)</p>  <p>xx1800003065</p>

Adjusting the axis-1 timing belt tension

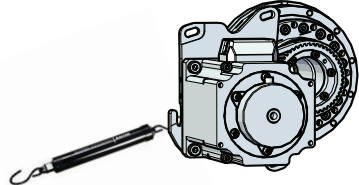

	Action	Note
1	<p>For robots with protection type Clean Room: Clean the joints that have been opened and wipe the parts free from particles with spirit on a lint free.</p>	
2	<p>Use a handheld dynamometer hooking to the motor.</p>	 <p>xx1900000040</p>

Continues on next page

5 Repair

5.8.1 Replacing the axis-1 gearbox

Continued

	Action	Note
3	<p>Pull the dynamometer to make the tension falling in the allowed force range.</p> <p> Note</p> <p>During the measurement, make sure that all interferences that may affect the force are removed. Pay attention to the force application direction.</p>	<p>Used belt: 58.24-63.56 N New belt:83.2-90.8 N (for reference only)</p>  <p>xx1900000041</p>
4	Secure the motor with the screws.	Tightening torque: 3 Nm

Securing the brake release button

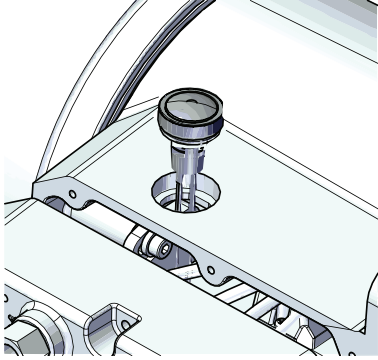



	Action	Note
1	For robots with protection type Clean Room: Clean the joints that have been opened and wipe the parts free from particles with spirit on a lint free.	
2	Tighten the brake release button using the tool.	<p>brake release button assembly tool, included in the special toolkit 3HAC071022-001</p>  <p>xx1800003040</p>

Refitting the lower cable package through the axis-1 gearbox

Notice that the procedure differs depending on if the connector interface is located either at the rear or at the bottom of the base.

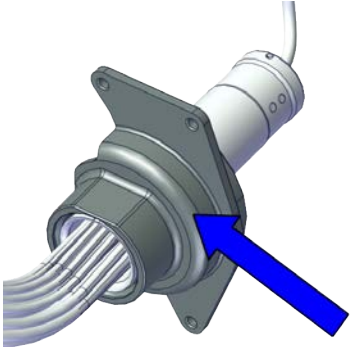
	Action	Note
1	For robots with protection type Clean Room: Clean the joints that have been opened and wipe the parts free from particles with spirit on a lint free.	

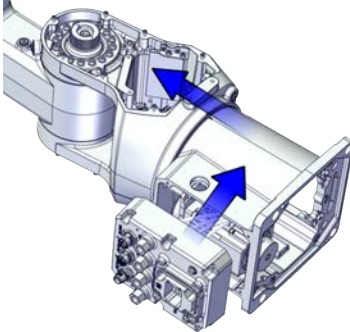
Continues on next page





	Action	Note
2	Refit the pulley cover to the lower cable package.	 <p>xx1800003046</p>
3	<p>Valid for cabling with rear interface Insert the cable package in the base and up through the axis-1 gearbox, through the rear.</p> <p> Tip Wrap the connectors with the masking tape.</p> <p> CAUTION Make sure that no cables or hoses are twisted or strained. Reroute if necessary.</p>	 <p>xx1800003047</p> <p>Cable protection tube orientation: use the encircled notch on the cable protection tube as a reference when inserting the cable package, which should be at the opposite direction to the locking screw hole on the gearbox.</p>  <p>xx1800003048</p>

Continues on next page

5 Repair

5.8.1 Replacing the axis-1 gearbox

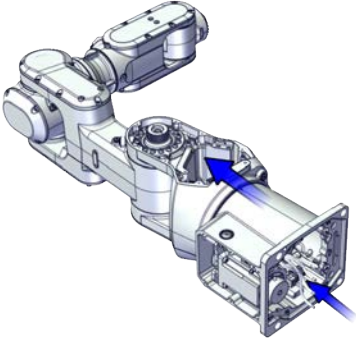
Continued

	Action	Note
4	<p>Valid for cabling with bottom interface (option 3309-1)</p> <p>Insert the cable package in the base and up through the axis-1 gearbox, through the bottom.</p> <p> Tip</p> <p>Wrap the connectors with the masking tape.</p> <p> CAUTION</p> <p>Make sure that no cables or hoses are twisted or strained. Reroute if necessary.</p>	 <p>xx1800003060</p> <p>Cable protection tube orientation: use the encircled notch on the cable protection tube as a reference when inserting the cable package, which should be at the opposite direction to the locking screw hole on the gearbox.</p>  <p>xx1800003048</p>

Securing the lower cable package to the axis-1 gearbox

	Action	Note
1	<p>For robots with protection type Clean Room: Clean the joints that have been opened and wipe the parts free from particles with spirit on a lint free.</p>	

Continues on next page

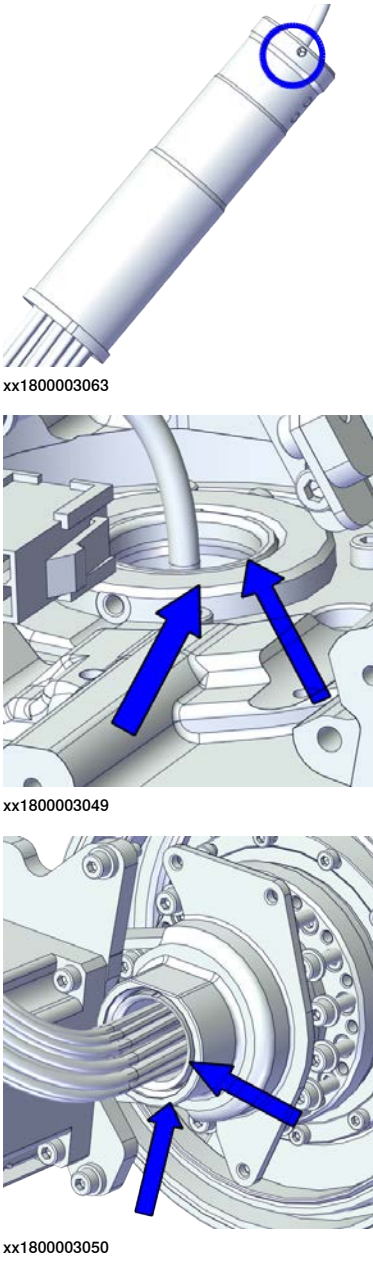

	Action	Note
2	<p>Make sure that:</p> <ul style="list-style-type: none">• The hole on the cable protection tube is aligned with the locking screw hole on the gearbox.• The cable protection tube surface is completely parallel with the pulley cover at one side and with the flange at the other side.	 <p>The note section contains three technical illustrations. The top illustration shows a cable protection tube with a blue circle highlighting a hole on its side, with the reference code 'xx1800003063' below it. The middle illustration shows the tube being inserted into a pulley cover, with two blue arrows pointing to the contact surfaces, and the reference code 'xx1800003049' below it. The bottom illustration shows the tube secured within a gearbox housing, with two blue arrows pointing to the locking screw holes, and the reference code 'xx1800003050' below it.</p>

Continues on next page

5 Repair

5.8.1 Replacing the axis-1 gearbox

Continued

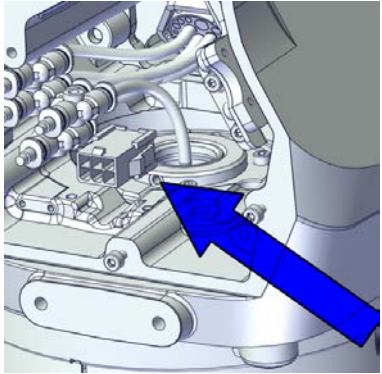
	Action	Note
3	<p>Apply a little Loctite 243 to the locking screw and refit the locking screw.</p> <p> Note</p> <p>Make sure the locking screw header is parallel with flange surface.</p> <p> Note</p> <p>If there is locking liquid residues on the screw or screw hole, please clean it before refitting. Remove residual locking liquid after refitting.</p>	<p>Screw: M3x8 (1 pcs) Tightening torque: 0.4 Nm</p>  <p>xx1800003032</p>

Refitting the pulley cover

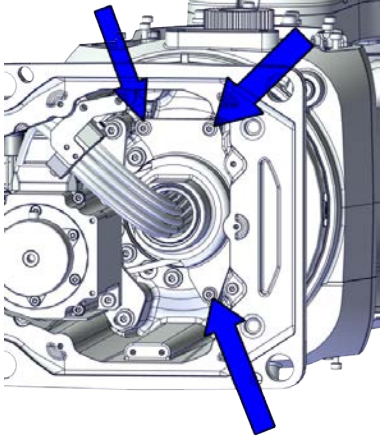
	Action	Note
1	<p>For robots with protection type Clean Room: Clean the joints that have been opened and wipe the parts free from particles with spirit on a lint free.</p>	
2	<p>Refit the puller cover.</p>	<p>Screw: M3x8 12.9 Lafre 2C2B/FC6.9 (3 pcs) Tightening torque: 1.2 Nm</p>  <p>xx1800003043</p>

Checking the SMB cover gasket



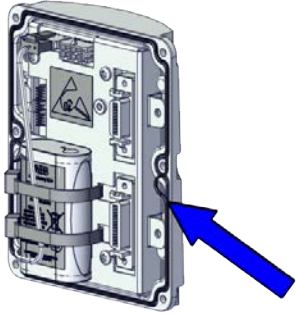

	Action	Note
1	<p>For robots with protection type Clean Room: Clean the joints that have been opened and wipe the parts free from particles with spirit on a lint free.</p>	

Continues on next page

5.8.1 Replacing the axis-1 gearbox
Continued

	Action	Note
2	<p>For robots with protection class IP67 (option 3350-670) For robots with protection type Clean Room (option 3351-4) Check the gasket. Replace if damaged.</p>	 <p>xx1900002186</p>

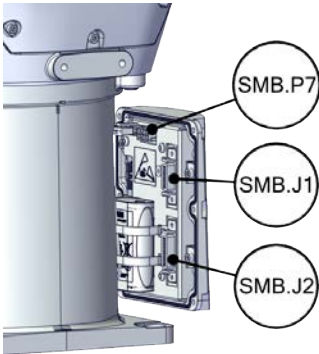
Reconnecting the SMB connectors

	Action	Note
1	 <p>ELECTROSTATIC DISCHARGE (ESD)</p> <p>The unit is sensitive to ESD. Before handling the unit read the safety information in section The unit is sensitive to ESD on page 49.</p>	
2	<p>For robots with protection type Clean Room Clean the joints that have been opened and wipe the parts free from particles with spirit on a lint free.</p>	
3	<p>Reconnect the connectors.</p> <ul style="list-style-type: none"> • SMB.P7 • SMB.J1 • SMB.J2  <p>Tip</p> <p>See the number markings on the connectors for help to find the corresponding connector.</p>	<p>Tightening torque: 0.3 Nm</p>  <p>xx1800002468</p>
4	<p>Route and secure the cabling with cable straps.</p>  <p>CAUTION</p> <p>Correct cable routing is highly important. If the cables are routed and secured incorrectly the cables can be damaged.</p>	

Continues on next page

5 Repair

5.8.1 Replacing the axis-1 gearbox

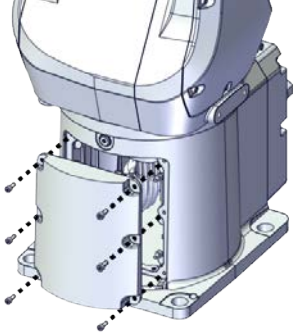

Continued

	Action	Note
5	Refit the SMB cover to the base.	<p>Screw: M3x8 12.9 Lafre 2C2B/FC6.9 (6 pcs) Tightening torque: 1.2 Nm</p>  <p>xx1800002467</p>

Refitting the connector interface plate

	Action	Note
1	For robots with protection type Clean Room: Clean the joints that have been opened and wipe the parts free from particles with spirit on a lint free.	

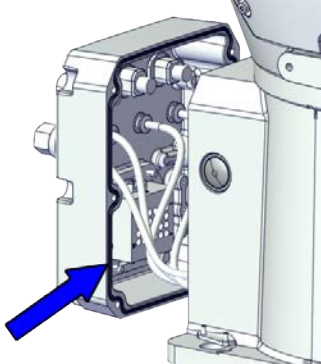
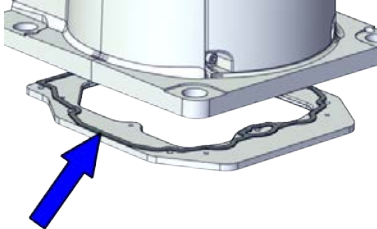
Continues on next page

	Action	Note
2	<p>For robots with protection class IP67 (option 3350-670) For robots with protection type Clean Room (option 3351-4) Check the gasket. Replace if damaged.</p>	<p>Valid for cabling with rear interface Gasket for base rear: 3HAC065350-001</p>  <p>xx1900002183</p> <p>Valid for cabling with bottom interface (option 3309-1) Gasket for base bottom: 3HAC065345-001</p>  <p>xx1900002188</p>
3	<p>Route and secure the cabling with cable straps.</p> <p> CAUTION</p> <p>Correct cable routing is highly important. If the cables are routed and secured incorrectly the cables can be damaged.</p>	

Continues on next page

5 Repair

5.8.1 Replacing the axis-1 gearbox

Continued

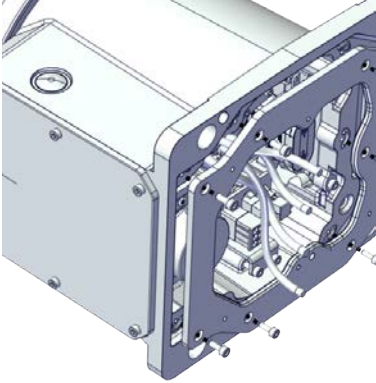
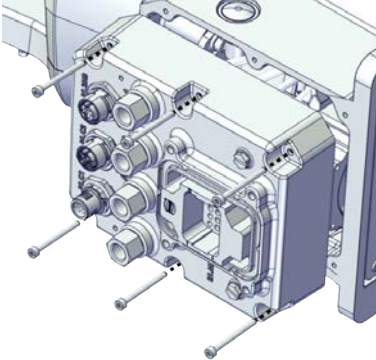
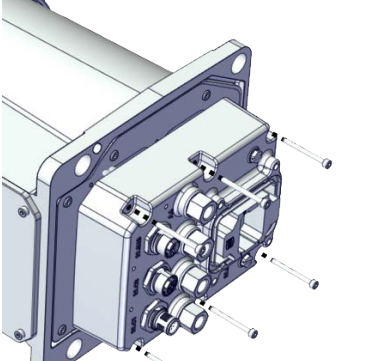
	Action	Note
4	Valid for cabling with bottom interface (option 3309-1) Refit the base adapter.	Screw: M3x8 Steel 8.8-A2F (7 pcs) Tightening torque: 1.2 Nm  xx1800003056
5	Refit the connector interface plate to the base.	Screw: M3x30 12.9 Lafre 2C2B/FC6.9 (6 pcs) Tightening torque: 1.2 Nm Valid for cabling with rear interface  xx1800003034 Valid for cabling with bottom interface (option 3309-1)  xx1800003055

Continues on next page

5.8.1 Replacing the axis-1 gearbox
Continued

Securing the lower cable package to the base

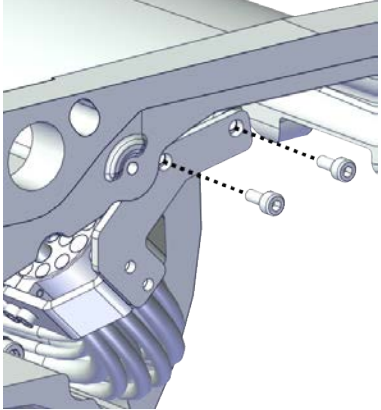
	Action	Note
1	For robots with protection type Clean Room: Clean the joints that have been opened and wipe the parts free from particles with spirit on a lint free.	
2	Refit the cable bracket.	Screw: M2.5x6 12.9 Lafre 2C2B/FC6.9 (2 pcs) Tightening torque: 0.6 Nm  xx1800003042

Reconnecting the brake release cabling and axis-1 motor connectors

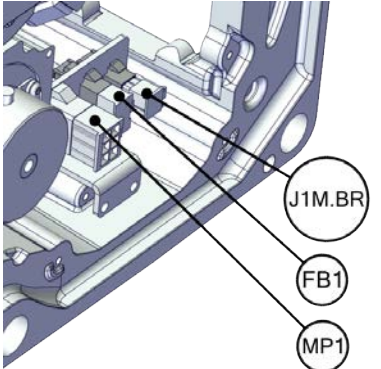
	Action	Note
1	For robots with protection type Clean Room: Clean the joints that have been opened and wipe the parts free from particles with spirit on a lint free.	
2	Reconnect the connectors. <ul style="list-style-type: none"> • J1M.BR • MP1 • FB1  Tip See the number markings on the connectors for help to find the corresponding connector.	 xx1800003054

Continues on next page

5 Repair

5.8.1 Replacing the axis-1 gearbox

Continued

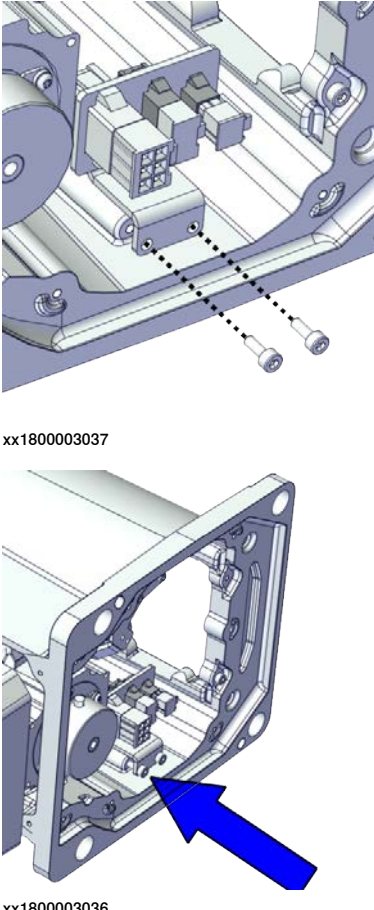

	Action	Note
3	Reconnect the floor cable together with the connector plate.	<p>Screw: M3x8 12.9 Lafre 2C2B/FC6.9 (2 pcs) Tightening torque: 0.8 Nm</p>  <p>xx1800003037</p> <p>xx1800003036</p>

Refitting the base cover

Notice that the procedure differs depending on if the connector interface is located either at the rear or at the bottom of the base.

	Action	Note
1	For robots with protection type Clean Room: Clean the joints that have been opened and wipe the parts free from particles with spirit on a lint free.	

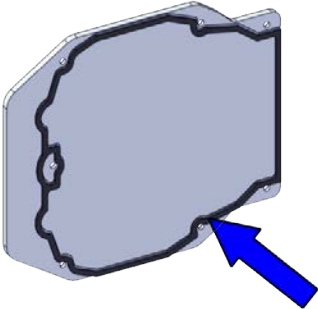
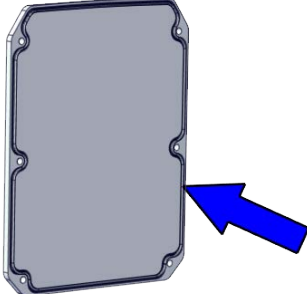
Continues on next page

	Action	Note
2	<p>For robots with protection class IP67 (option 3350-670) For robots with protection type Clean Room (option 3351-4) Check the gasket. Replace if damaged.</p>	<p>Valid for cabling with rear interface Gasket for base bottom: 3HAC065345-001</p>  <p>xx1900002184</p> <p>Valid for cabling with bottom interface (option 3309-1) Gasket for base rear: 3HAC065350-001</p>  <p>xx1900002189</p>
3	<p>Apply grease to the cable package, cover all moving area of the package.</p>	
4	<p>Apply grease to the covers that have contacting area with the cable package.</p>	
5	<p>Route and secure the cabling with cable straps.</p> <p> CAUTION</p> <p>Correct cable routing is highly important. If the cables are routed and secured incorrectly the cables can be damaged.</p>	

Continues on next page

5 Repair

5.8.1 Replacing the axis-1 gearbox

Continued

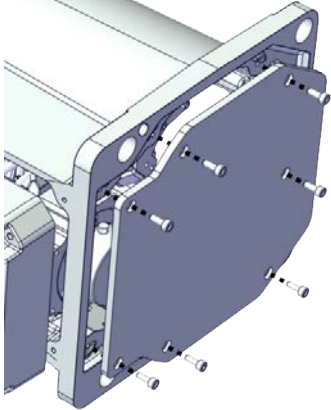
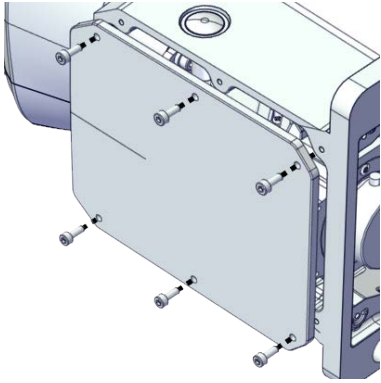

	Action	Note
6	Valid for cabling with rear interface Refit the bottom cover.	Screw: M3x8 Steel 8.8-A2F (7 pcs) Tightening torque: 1.2 Nm  xx1800003035
7	Refit the rear cover.	Screw: M3x8 12.9 Lafre 2C2B/FC6.9 (6 pcs) Tightening torque: 1.2 Nm  xx1800003057

Securing the robot to the foundation

	Action	Note
1	For robots with protection type Clean Room: Clean the joints that have been opened and wipe the parts free from particles with spirit on a lint free.	
2	 CAUTION The IRB 1100 robot weighs 21.1 kg and can be lifted by one person.	
3	Raise the robot to standing and secure to the foundation with the attachment screws and washers.	Attachment screws: M12x25 (robot installation directly on foundation), quality: 8.8. Washers: 24 x 13 x 2.5, steel hardness class 200HV. Tightening Torque: 50 Nm±5 Nm.

Continues on next page

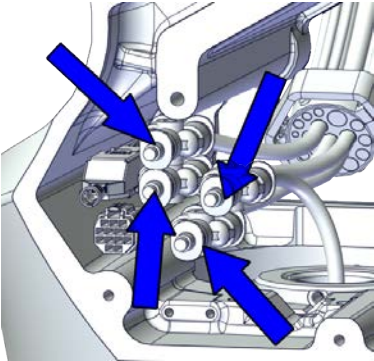
Reconnecting the air hoses, CP/CS cabling and Ethernet cabling (if equipped)

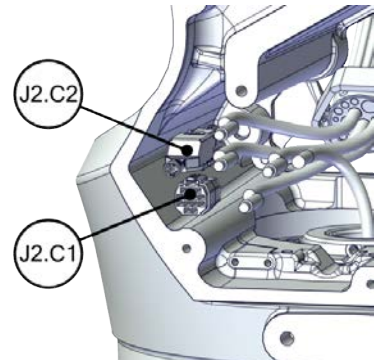
	Action	Note
1	<p>For robots with protection type Clean Room: Clean the joints that have been opened and wipe the parts free from particles with spirit on a lint free.</p>	
2	<p>Reconnect the air hoses in a cross pattern to the Y-shaped connectors.</p> <p> Tip</p> <p>See the number markings on the air hoses for help to find the corresponding air hoses. The air hoses with the same number connect to the same Y-shaped connector.</p>	 <p>xx1800002500</p>
3	<p>Reconnect the connectors.</p> <ul style="list-style-type: none"> • J2.C1 • J2.C2 <p> Tip</p> <p>See the number markings on the connectors for help to find the corresponding connector.</p>	 <p>xx1800002501</p>

Securing the cable package to the swing

	Action	Note
1	<p>For robots with protection type Clean Room: Clean the joints that have been opened and wipe the parts free from particles with spirit on a lint free.</p>	

Continues on next page

5 Repair

5.8.1 Replacing the axis-1 gearbox



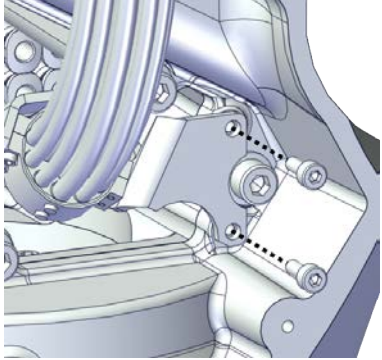

Continued

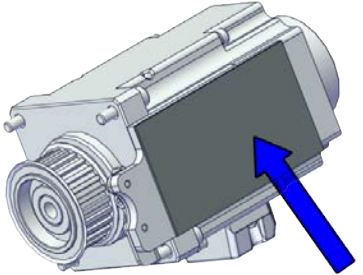
	Action	Note
2	Refit the cable bracket.	<p>Screw: M3x8 12.9 Lafre 2C2B/FC6.9 (2 pcs) Tightening torque: 0.8 Nm</p>  <p>xx1800002499</p>

Refitting the axis-2 motor

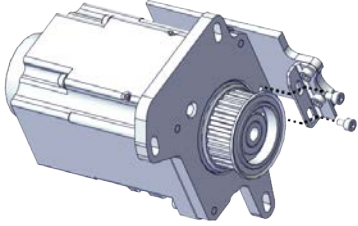
	Action	Note
1	For robots with protection type Clean Room: Clean the joints that have been opened and wipe the parts free from particles with spirit on a lint free.	
2	Check that: <ul style="list-style-type: none"> • all assembly surfaces are clean and without damages • the motor is clean and undamaged. 	
3	Check the cooling pad. Replace if damaged, as shown in the following step.	<p>Cooling pad for axis-1 and -2 motors: 3HAC071020-001</p>  <p>xx1800003603</p>

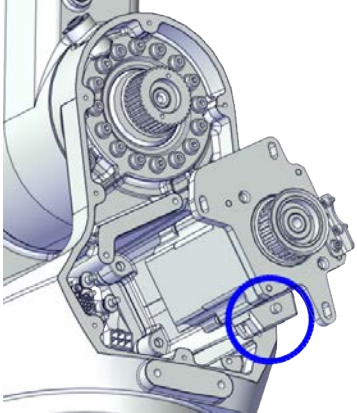
Continues on next page

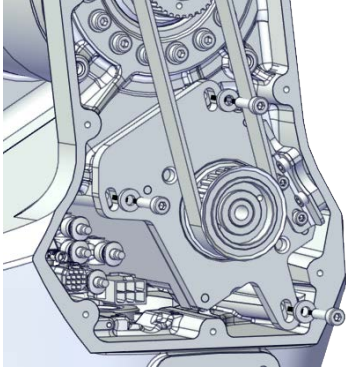

	Action	Note
4	<p>Remove the screws. Replace with a new cooling pad and then refit the screws.</p>	<p>Screw: M3x5 12.9 Lafre 2C2B/FC6.9 (2 pcs) Tightening torque: 1.2 Nm</p>  <p>xx1800003026</p>
5	<p>Orient the motor correctly and fit it into the swing.</p> <p> Tip</p> <p>Bend the motor signal cable back towards the swing support.</p>	<p>Motor orientation: orient the motor according to the figure below, in regard to the encircled motor connector.</p>  <p>xx1800003027</p>
6	<p>Refit the screws and washers.</p> <p> Note</p> <p>Do not tighten the screws yet.</p>	<p>Screw: M4x16 12.9 Lafre 2C2B/FC6.9 (3 pcs) Washer, 3HAC063985-001 (3 pcs)</p>  <p>xx1800002494</p>

Continues on next page

5 Repair

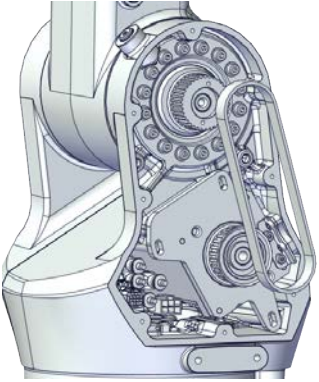

5.8.1 Replacing the axis-1 gearbox

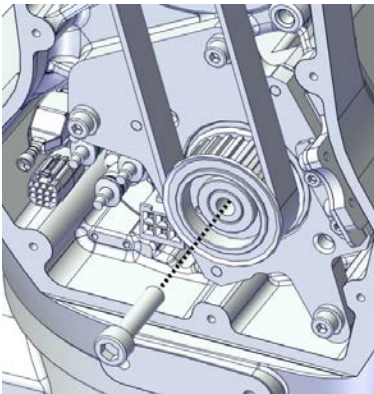
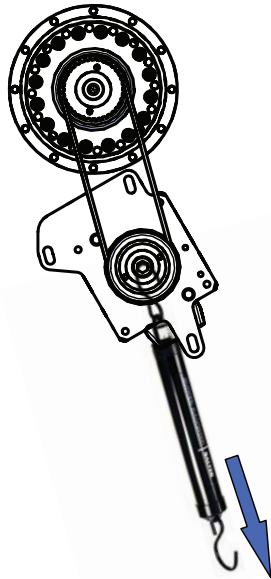
Continued

	Action	Note
7	Install the timing belt to the pulleys and verify that the belt runs correctly in the grooves of the pulleys.	 <p>xx1800003028</p>
8	Install an M6x25 or longer adjustment screw to the motor.  Note Do not insert the entire screw to the hole.	 <p>xx1900000010</p>
9	Use a handheld dynamometer hooking to the screw and pull the dynamometer to reach the initial referenced force.	Initial referenced force for used belt: 68.18-75.04 N (for reference only) Initial referenced force for new belt: 97.4-107.2 N  <p>xx1900000029</p>

Continues on next page

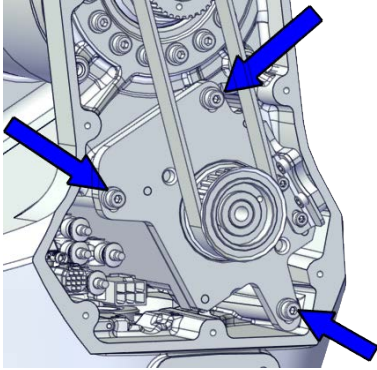
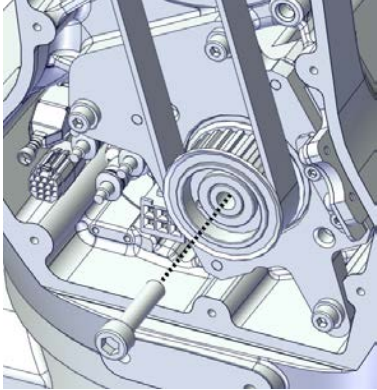
5.8.1 Replacing the axis-1 gearbox
Continued

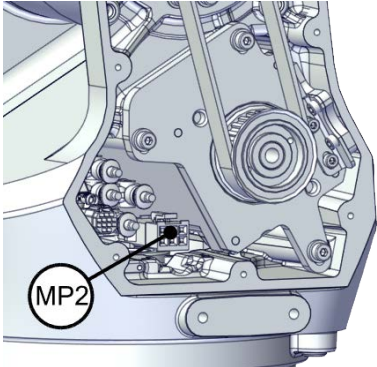
	Action	Note
10	Secure the motor with the screws.	<p>Tightening torque: 3.5 Nm</p>  <p>xx1800002493</p>
11	Use a sonic tension meter to measure the timing belt tension.	<p>Used belt: 163-174 Hz New belt: 180-229 Hz (for reference only)</p>
12	If the timing belt tension does not meet the requirement, loosen the motor screws and readjust.	
13	Remove the adjustment screw from the motor.	 <p>xx1900000010</p>
14	<p>Reconnect the connector.</p> <ul style="list-style-type: none"> • MP2 <p> Tip</p> <p>See the number markings on the connectors for help to find the corresponding connector.</p>	 <p>xx1800002495</p>





Continues on next page

5 Repair

5.8.1 Replacing the axis-1 gearbox

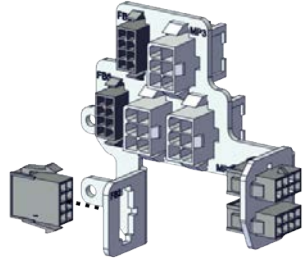
Continued

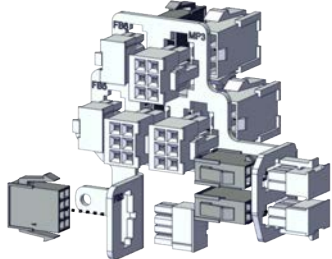
Reconnecting the connectors at the division point

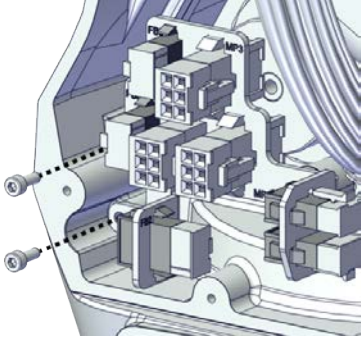
	Action	Note
1	For robots with protection type Clean Room: Clean the joints that have been opened and wipe the parts free from particles with spirit on a lint free.	
2	Insert the female header of the connectors to the connector plate.	 xx1800003029
3	Reconnect the connectors. <ul style="list-style-type: none"> • J2.FB2,3,4,5,6 • J2.MP3,4,5/6  Tip See the number markings on the connectors for help to find the corresponding connector.	 xx1800003030
4	Route and secure the cabling with cable straps.  CAUTION Correct cable routing is highly important. If the cables are routed and secured incorrectly the cables can be damaged.	
5	Refit the connector plate.	Screw: M3x8 12.9 Lafre 2C2B/FC6.9 (2 pcs) Tightening torque: 0.8 Nm  xx1800002489

Continues on next page

Refitting the swing covers

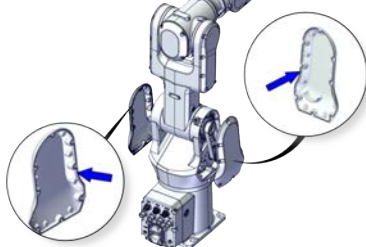
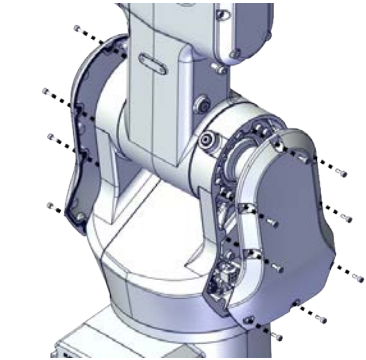
	Action	Note
1	For robots with protection type Clean Room: Clean the joints that have been opened and wipe the parts free from particles with spirit on a lint free.	
2	For robots with protection class IP67 (option 3350-670) For robots with protection type Clean Room (option 3351-4) Check the gaskets. Replace if damaged.	 xx1900002175
3	Apply grease to the cable package, cover all moving area of the package.	
4	Apply grease to the covers that have contacting area with the cable package.	
5	Refit the covers. <ul style="list-style-type: none"> • Swing cover • Swing support cover 	Screw: M3x8 12.9 Lafre 2C2B/FC6.9 Tightening torque: 1.2 Nm  xx1800003607

Concluding procedure

	Action	Note
1	For robots with protection type Clean Room: Clean and paint the joints that have been opened. See Cut the paint or surface on the robot before replacing parts on page 124  Note After all repair work, wipe the Clean Room robot free from particles with spirit on a lint free cloth.	
2	Recalibrate the robot.	Calibration is detailed in section Calibration on page 685 .

Continues on next page

5 Repair

5.8.1 Replacing the axis-1 gearbox

Continued

	Action	Note
3	 DANGER Make sure all safety requirements are met when performing the first test run. See Test run after installation, maintenance, or repair on page 91 .	

5.8.2 Replacing the axis-2 gearbox

Location of the axis-2 gearbox

The axis-2 gearbox is located as shown in the figure.

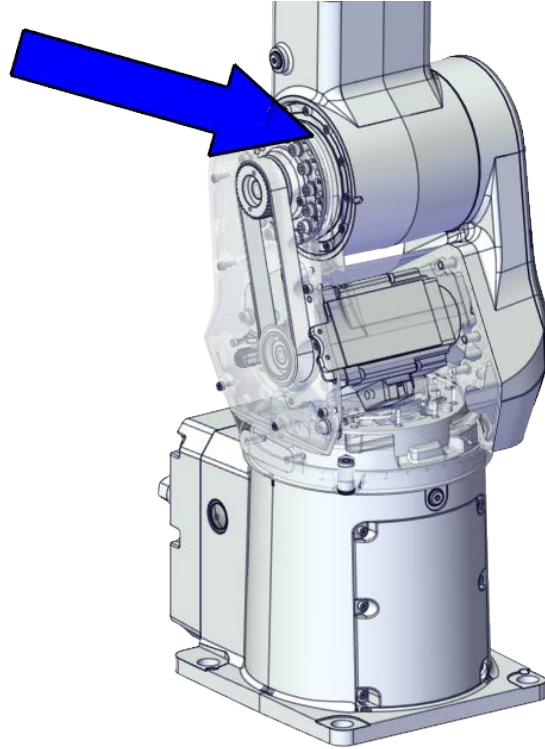

xx1800002479

Required spare parts



Note

The spare part numbers that are listed in the table can be out of date. See the latest spare parts of the IRB 1100 via myABB Business Portal, www.abb.com/myABB.

Spare part	Article number	Note
Gear unit with pulley, axis 2	3HAC073517-001	
O-ring on circular spline side	3HAB3772-143	Used with protection class IP67 and protection type Clean Room. Replace if damaged.
O-ring on flexible spline side	3HAB3772-182	Used with protection class IP67 and protection type Clean Room. Replace if damaged.
Axis-2 radial sealing	3HAB3701-70	Used with protection class IP67 and protection type Clean Room. Replace if damaged.

Continues on next page

5 Repair

5.8.2 Replacing the axis-2 gearbox

Continued

Spare part	Article number	Note
Motor with flange, axis 2	3HAC083588-001	.
Timing belt, axis 2	3HAC061935-001	
Swing cover	3HAC069051-001	
Swing cover, Clean Room	3HAC075498-001	Used with protection type Clean Room.
Swing support cover	3HAC069052-001	
Swing support cover, Clean Room	3HAC075500-001	Used with protection type Clean Room.
Gasket for swing cover	3HAC061959-003	Used with protection class IP67 and protection type Clean Room. Replace if damaged.
Gasket for swing support cover	3HAC065317-001	Used with protection class IP67 and protection type Clean Room. Replace if damaged.
Cooling pad for axis-1 and -2 motors	3HAC071020-001	Cooling pads are wear parts. One cooling pad sheet contains 6 pieces of small pad. Replace if damaged with one piece each time.
Washer	3HAC063985-001	9x4.3x1, Steel

Required tools and equipment

Equipment	Article number	Note
Standard toolkit	-	Content is defined in section Standard toolkit on page 733 .
Calibration tool box, Axis Calibration	3HAC074119-001	Delivered as a set of calibration tools. Required if Axis Calibration is the valid calibration method for the robot. The tool box also includes a unique calibration pin for IRB 1100 to be fitted to the tool flange during calibration of axis 6.
24 VDC power supply	-	Used to release the motor brakes.
Sonic tension meter	-	Used for measuring the timing belt tension.
Dynamometer	-	Used for measuring the timing belt tension.

Required consumables

Consumable	Article number	Note
Cable straps	-	
Grease	3HAC029132-001	FM 222

Continues on next page

Consumable	Article number	Note
Grease	-	Castrol Molub. Alloy 777-1 NG Used to lubricate bearings on the swing support and lower arm support.

Deciding calibration routine

Decide which calibration routine to be used, based on the information in the table. Depending on which routine is chosen, action might be required prior to beginning the repair work of the robot, see the table.

	Action	Note
1	Decide which calibration routine to use for calibrating the robot. <ul style="list-style-type: none"> Reference calibration. External cable packages (DressPack) and tools can stay fitted on the robot. Fine calibration. All external cable packages (DressPack) and tools must be removed from the robot. 	 Note Calibrating axis 6 always requires tools to be removed from the mounting flange (also for reference calibration) since the mounting flange is used for installation of the calibration tool.
	If the robot is to be calibrated with reference calibration: Find previous reference values for the axis or create new reference values. These values are to be used after the repair procedure is completed, for calibration of the robot. If no previous reference values exist, and no new reference values can be created, then reference calibration is not possible.	Follow the instructions given in the reference calibration routine on the FlexPendant to create reference values. Creating new values requires possibility to move the robot. Read more about reference calibration for Axis Calibration in Reference calibration routine on page 696 .
	If the robot is to be calibrated with fine calibration: Remove all external cable packages (DressPack) and tools from the robot.	

Removing the gearbox

Use these procedures to remove the axis-2 gearbox.

Preparations before removing the axis-2 gearbox



	Action	Note
1	Decide which calibration routine to use, and take actions accordingly prior to beginning the repair procedure.	

Continues on next page

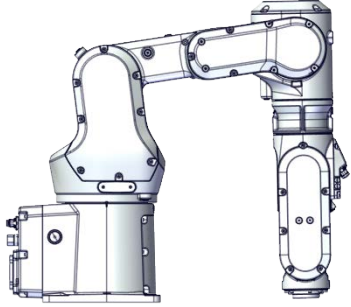

5 Repair

5.8.2 Replacing the axis-2 gearbox





Continued

	Action	Note
2	<p>Jog the robot to the specified position:</p> <ul style="list-style-type: none"> • Axis 1: 0° • Axis 2: 110° (IRB 1100-4/0.475) /95° (IRB 1100-4/0.58) • Axis 3: -20° (IRB 1100-4/0.475)/ -6° (IRB 1100-4/0.58) • Axis 4: 0° • Axis 5: 0° • Axis 6: No significance. 	 <p>xx1800003289</p>
3	<p> DANGER</p> <p>Turn off all:</p> <ul style="list-style-type: none"> • electric power supply • hydraulic pressure supply • air pressure supply <p>to the robot, before entering the safeguarded space.</p>	
4	<p> CAUTION</p> <p>For robots with protection type Clean Room Always cut the paint with a knife and grind the paint edge when disassembling parts of the robot! See Cut the paint or surface on the robot before replacing parts on page 124.</p>	

Removing the axis-2 motor

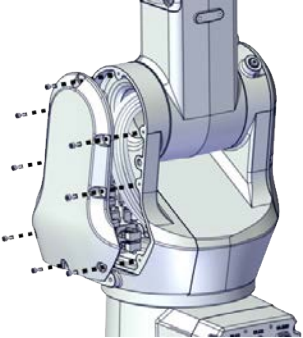
	Action	Note
1	<p> DANGER</p> <p>Make sure that all supplies for electrical power, hydraulic pressure, and air pressure are turned off.</p>	
2	<p> CAUTION</p> <p>For robots with protection type Clean Room Always cut the paint with a knife and grind the paint edge when disassembling parts of the robot! See Cut the paint or surface on the robot before replacing parts on page 124.</p>	

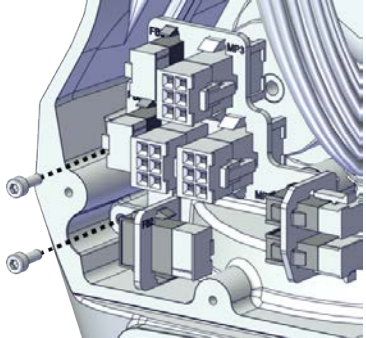
Continues on next page

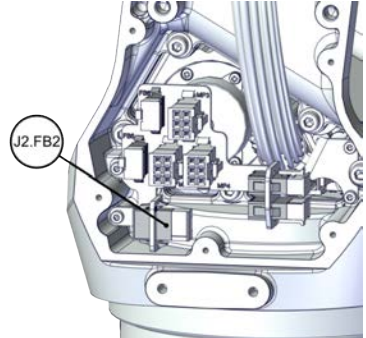

	Action	Note
3	<p> CAUTION</p> <p>Removing motors will release axes. This means the axes can fall down. Make sure axes are well supported before removing motors.</p>	
4	Remove the swing support cover.	 <p>xx1800002488</p>
5	<p>Remove the connector plate.</p> <p> CAUTION</p> <p>Be aware of the cablings that are attached to the connector plate! The connector plate cannot be removed completely until the connectors are removed from the plate.</p>	 <p>xx1800002489</p>
6	<p>Disconnect the connector.</p> <ul style="list-style-type: none"> • J2.FB2 <p> Tip</p> <p>Take photos of the connector and cable position before disconnecting them, to have as a reference when reconnecting.</p>	 <p>xx1800002490</p>

Continues on next page

5 Repair

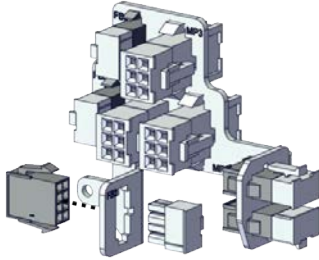
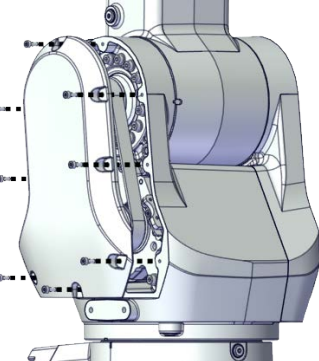

5.8.2 Replacing the axis-2 gearbox

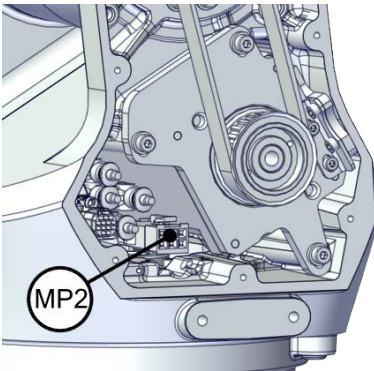
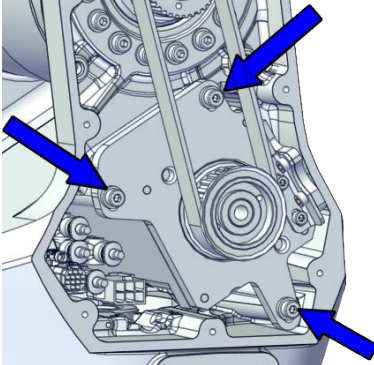
Continued

	Action	Note
7	Snap loose and remove the female head of the connector from the connector plate.	 xx1800002491
8	Remove the swing cover.	 xx1800002492
9	Disconnect the connector. <ul style="list-style-type: none">• MP2  Tip Take photos of the connector and cable position before disconnecting them, to have as a reference when reconnecting.	 xx1800002495
10	Loosen the screws and move the motor slightly to slacken the timing belt.	 xx1800002493

Continues on next page

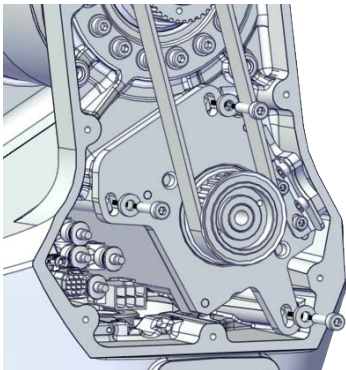
5.8.2 Replacing the axis-2 gearbox
Continued

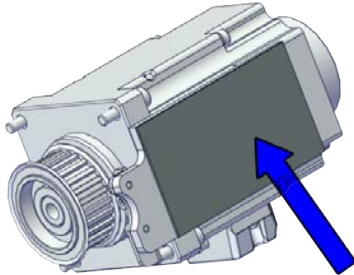
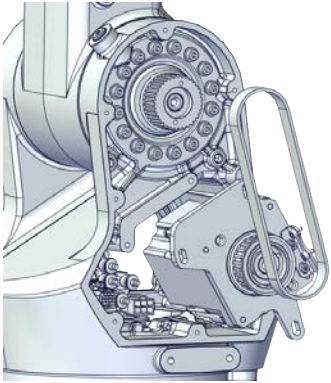
	Action	Note
11	Remove the screws and washers.	 <p>xx1800002494</p>
12	<p>Carefully lift out the motor.</p> <p> CAUTION</p> <p>A cooling pad is attached to the motor, which may stick to the casting. Always use a plastic sheet with caution to remove the pad from the casting. Pay attention not to scratch the casting or damage the pad.</p> <p> CAUTION</p> <p>Be aware of the motor cabling. The motor cannot be removed completely until the connector is disconnected, as shown in following step.</p>	<p>Cooling pad location</p>  <p>xx1800003603</p>
13	Remove the timing belt from its groove on the motor.	 <p>xx1800002496</p>

Separating the upper cable harness from the axis-2 gearbox

	Action	Note
1	<p> DANGER</p> <p>Make sure that all supplies for electrical power, hydraulic pressure, and air pressure are turned off.</p>	

Continues on next page



5 Repair

5.8.2 Replacing the axis-2 gearbox

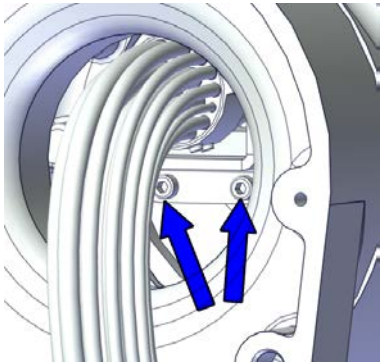

Continued

	Action	Note
2	 CAUTION For robots with protection type Clean Room Always cut the paint with a knife and grind the paint edge when disassembling parts of the robot! See <i>Cut the paint or surface on the robot before replacing parts on page 124.</i>	
3	Remove the cable bracket.	 <small>xx1800003002</small>



Loosening the swing support

	Action	Note
1	 DANGER Make sure that all supplies for electrical power, hydraulic pressure, and air pressure are turned off.	
2	 CAUTION For robots with protection type Clean Room Always cut the paint with a knife and grind the paint edge when disassembling parts of the robot! See <i>Cut the paint or surface on the robot before replacing parts on page 124.</i>	

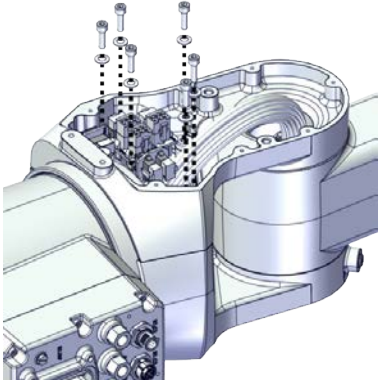
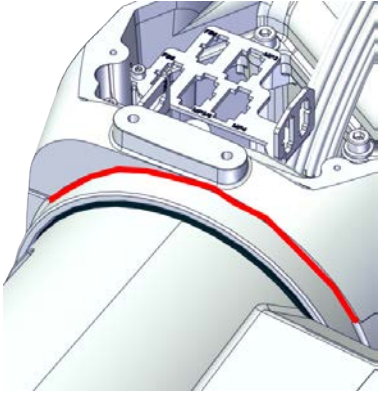
Continues on next page

	Action	Note
3	<p>Loosen the swing support screws.</p> <p> Note</p> <p>For Clean Room robots, the swing support is sealed with sealant (marked red in the figure). Always remove swing support carefully.</p> <p> Tip</p> <p>If the swing support is hard to loosen from the lower arm, use a plastic hammer to knock on the swing support lightly.</p> <p> CAUTION</p> <p>The support cannot be removed completely. Make sure the hanging support will not wear or damage the cable harness.</p>	 <p>xx1800003079</p>  <p>xx2000000321</p>

Separating the swing from the lower arm



	Action	Note
1	<p> DANGER</p> <p>Make sure that all supplies for electrical power, hydraulic pressure, and air pressure are turned off.</p>	
2	<p> CAUTION</p> <p>For robots with protection type Clean Room</p> <p>Always cut the paint with a knife and grind the paint edge when disassembling parts of the robot! See Cut the paint or surface on the robot before replacing parts on page 124.</p>	

Continues on next page

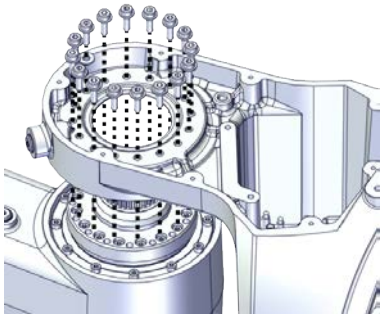

5 Repair

5.8.2 Replacing the axis-2 gearbox

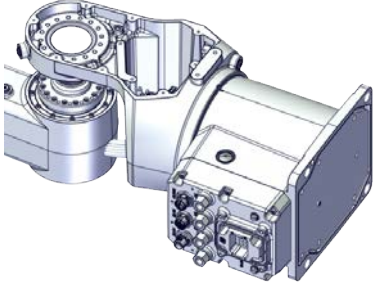
Continued

	Action	Note
3	<p>Remove the screws.</p> <p> Note</p> <p>Some robots may be fitted with separate screws and washers. During replacement, always use the same screws (and washers) that are fitted on the robot at delivery. Contact ABB for more information.</p>	 <p>xx1900002203</p>
4	<p>Separate the swing from the lower arm.</p> <p> Tip</p> <p>If the swing is hard to loosen from the housing, use a plastic hammer to knock on the swing lightly.</p>	 <p>xx1800003081</p>



Removing the axis-2 gearbox

	Action	Note
1	<p> DANGER</p> <p>Make sure that all supplies for electrical power, hydraulic pressure, and air pressure are turned off.</p>	
2	<p> CAUTION</p> <p>For robots with protection type Clean Room Always cut the paint with a knife and grind the paint edge when disassembling parts of the robot! See Cut the paint or surface on the robot before replacing parts on page 124.</p>	
3	<p> CAUTION</p> <p>Removing gearboxes will release axes. This means the axes can fall down. Make sure axes are well supported before removing gearboxes.</p>	
4	<p>Move the lower arm aside a little to access the gearbox screws.</p>	

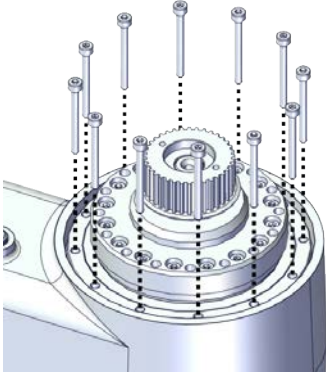
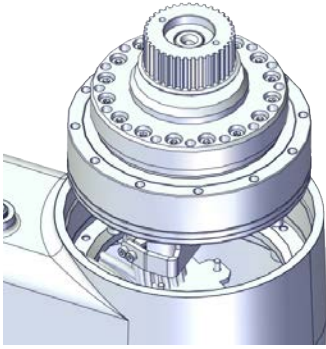
Continues on next page

	Action	Note
5	Remove the screws.	 <p>xx1800003082</p>
6	Pull out the gearbox.	 <p>xx1800003083</p>

Removing the cable block

	Action	Note
1	 <p>DANGER</p> <p>Make sure that all supplies for electrical power, hydraulic pressure, and air pressure are turned off.</p>	
2	 <p>CAUTION</p> <p>For robots with protection type Clean Room Always cut the paint with a knife and grind the paint edge when disassembling parts of the robot! See Cut the paint or surface on the robot before replacing parts on page 124.</p>	

Continues on next page

5 Repair

5.8.2 Replacing the axis-2 gearbox

Continued

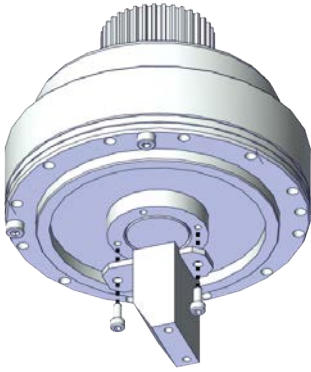
	Action	Note
3	Remove the cable block from the gearbox.	 <p>xx1800003084</p>

Refitting the gearbox

Use these procedures to refit the axis-2 gearbox.

Refitting the cable block

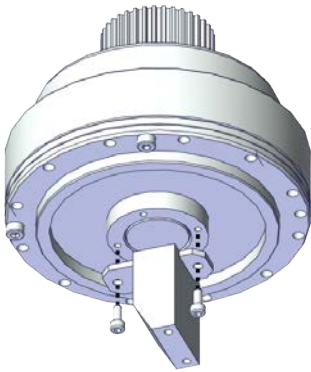
	Action	Note
1	For robots with protection type Clean Room: Clean the joints that have been opened and wipe the parts free from particles with spirit on a lint free.	
2	Refit the cable block to the axis-2 gearbox.	<p>Screw: M2.5x6 12.9 Lafre 2C2B/FC6.9 (2 pcs) Tightening torque: 0.6 Nm</p>  <p>xx1800003084</p>

Refitting the axis-2 gearbox

	Action	Note
1	For robots with protection type Clean Room: Clean the joints that have been opened and wipe the parts free from particles with spirit on a lint free.	

Continues on next page

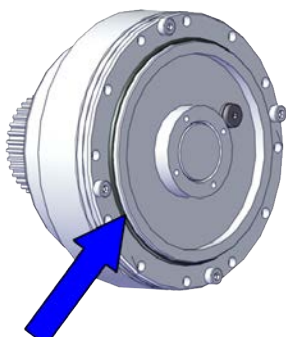
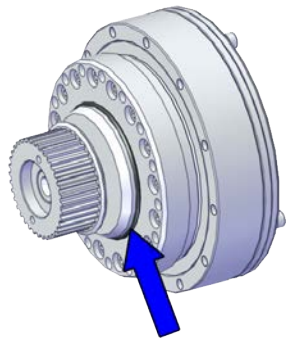
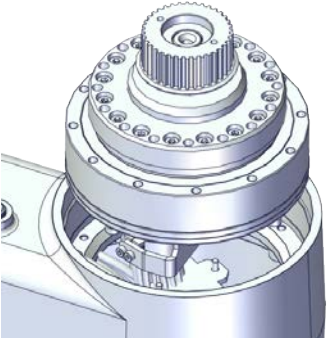
	Action	Note
2	<p>For robots with protection class IP67 (option 3350-670) For robots with protection type Clean Room (option 3351-4) Check the O-rings. Replace if damaged.</p>	<p>O-ring on flexible spline side: 3HAB3772-182</p>  <p>xx1900002195</p> <p>O-ring on circular spline side: 3HAB3772-143</p>  <p>xx1900002194</p>
3	<p>Refit the axis-2 gearbox.</p>	 <p>xx1800003083</p>

Continues on next page

5 Repair

5.8.2 Replacing the axis-2 gearbox

Continued

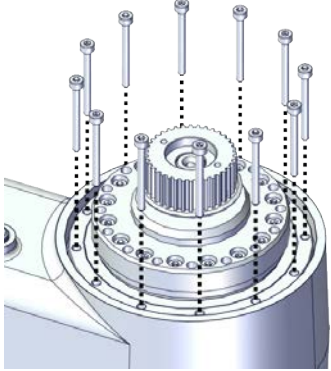
	Action	Note
4	Secure with screws.	<p>Screw: M3x30 12.9 Lafre 2C2B/FC6.9 (12 pcs) Tightening torque: 1.9 Nm</p>  <p>xx1800003082</p>

Refitting the swing to the lower arm

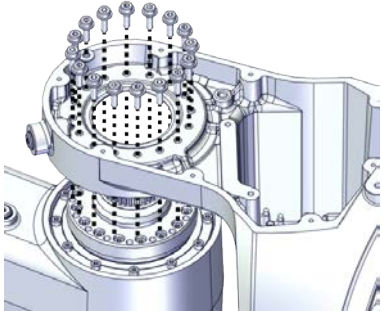
	Action	Note
1	For robots with protection type Clean Room: Clean the joints that have been opened and wipe the parts free from particles with spirit on a lint free.	
2	Refit the swing to the lower arm.  Note Some robots may be fitted with separate screws and washers. During replacement, always use the same screws (and washers) that are fitted on the robot at delivery. Contact ABB for more information.	<p>Flange screws (16 pcs) For robots with protection class IP40 Tightening torque: 4.2 Nm For robots with protection class IP67 For robots with protection type Clean Room Tightening torque: 4 Nm</p>  <p>xx1900002203</p>

Checking the radial sealing on the swing support (IP67 or Clean Room)

	Action	Note
1	For robots with protection type Clean Room: Clean the joints that have been opened and wipe the parts free from particles with spirit on a lint free.	

Continues on next page

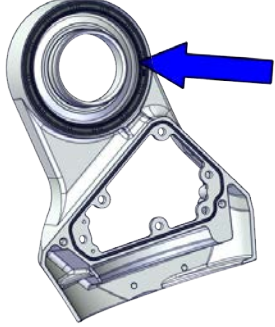
	Action	Note
2	Check the radial sealing on the swing support.	 <p>xx1900002201</p>
3	Replace the radial sealing if damaged. The swing support must be removed completely before the radial sealing can be removed. See Replacing the swing on page 276 .	Axis-2 radial sealing assembly tool, included in the radial sealing assembly tool set 3HAC074609-001.

Securing the swing support

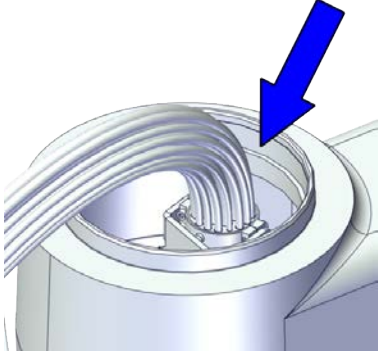
	Action	Note
1	For robots with protection type Clean Room: Clean the joints that have been opened and wipe the parts free from particles with spirit on a lint free.	
2	Apply grease Castrol Molub-Alloy 777-1 NG to the inner surface of the lower arm, where contacts the bearing on the swing support.	 <p>xx2000000058</p>

Continues on next page

5 Repair

5.8.2 Replacing the axis-2 gearbox

Continued

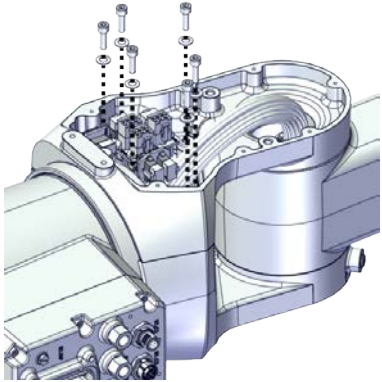
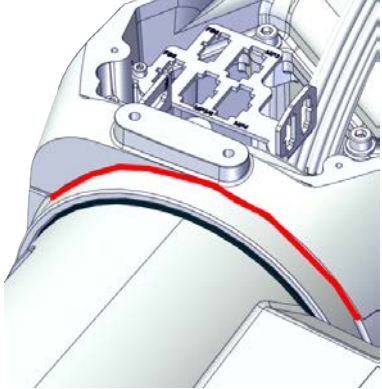
	Action	Note
3	<p>Refit the swing support.</p> <p> Tip</p> <p>If the swing support is hard to closely fit to the lower arm, use a plastic hammer to knock on the swing support lightly.</p>	<p>Screw: M5x16 12.9 Lafre 2C2B/FC6.9 (6 pcs) Tightening torque: 6 Nm</p>  <p>xx1800003079</p>
4	<p>For robots with protection type Clean Room (option 3351-4)</p> <p>Apply a string of the sealant Sikaflex 521FC to the joint of the swing support. Smooth out the sealant string using a finger tip.</p> <p>Use washing-up on finger tips to get a smooth joint.</p> <p>If necessary, add extra sealant to get a full cover joint.</p>	 <p>xx2000000321</p>

Securing the upper cable package to the axis-2 gearbox

	Action	Note
1	<p>For robots with protection type Clean Room:</p> <p>Clean the joints that have been opened and wipe the parts free from particles with spirit on a lint free.</p>	

Continues on next page

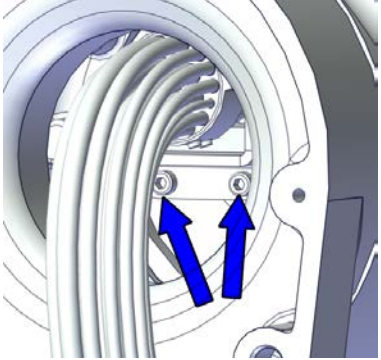
	Action	Note
2	Refit the cable bracket.	<p>Screw: M2.5x6 12.9 Lafre 2C2B/FC6.9 (2 pcs) Tightening torque: 0.6 Nm</p>  <p>xx1800003002</p>

Refitting the axis-2 motor

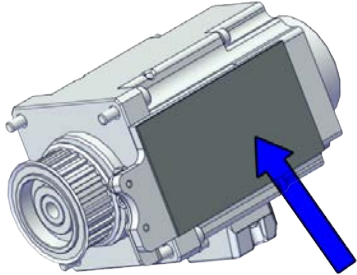



	Action	Note
1	For robots with protection type Clean Room: Clean the joints that have been opened and wipe the parts free from particles with spirit on a lint free.	
2	Check that: <ul style="list-style-type: none"> • all assembly surfaces are clean and without damages • the motor is clean and undamaged. 	
3	Check the cooling pad. Replace if damaged, as shown in the following step.	<p>Cooling pad for axis-1 and -2 motors: 3HAC071020-001</p>  <p>xx1800003603</p>

Continues on next page

5 Repair

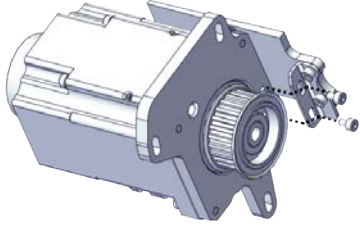

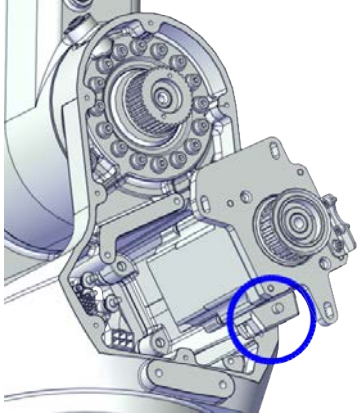
5.8.2 Replacing the axis-2 gearbox

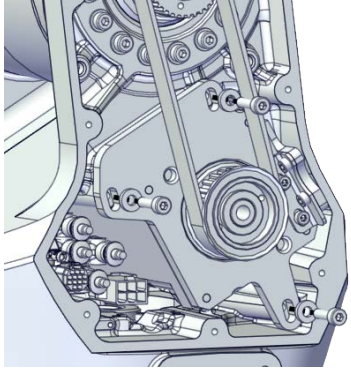
Continued

	Action	Note
4	<p>Remove the screws. Replace with a new cooling pad and then refit the screws.</p>	<p>Screw: M3x5 12.9 Lafre 2C2B/FC6.9 (2 pcs) Tightening torque: 1.2 Nm</p>  <p>xx1800003026</p>
5	<p>Orient the motor correctly and fit it into the swing.</p> <p> Tip</p> <p>Bend the motor signal cable back towards the swing support.</p>	<p>Motor orientation: orient the motor according to the figure below, in regard to the encircled motor connector.</p>  <p>xx1800003027</p>
6	<p>Refit the screws and washers.</p> <p> Note</p> <p>Do not tighten the screws yet.</p>	<p>Screw: M4x16 12.9 Lafre 2C2B/FC6.9 (3 pcs) Washer, 3HAC063985-001 (3 pcs)</p>  <p>xx1800002494</p>

Continues on next page

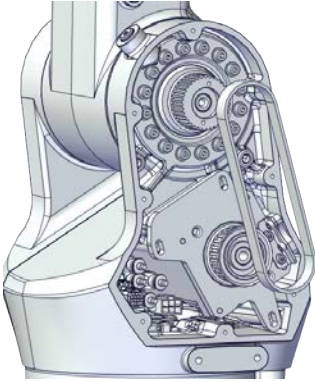
5.8.2 Replacing the axis-2 gearbox
Continued

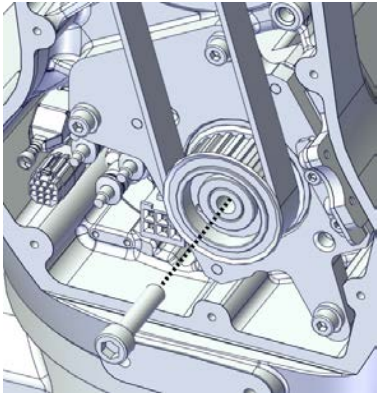
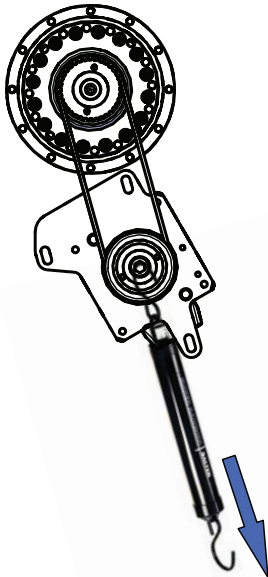

	Action	Note
7	Install the timing belt to the pulleys and verify that the belt runs correctly in the grooves of the pulleys.	 <p>xx1800003028</p>
8	Install an M6x25 or longer adjustment screw to the motor.  Note Do not insert the entire screw to the hole.	 <p>xx1900000010</p>
9	Use a handheld dynamometer hooking to the screw and pull the dynamometer to reach the initial referenced force.	Initial referenced force for used belt: 68.18-75.04 N (for reference only) Initial referenced force for new belt: 97.4-107.2 N  <p>xx1900000029</p>

Continues on next page

5 Repair



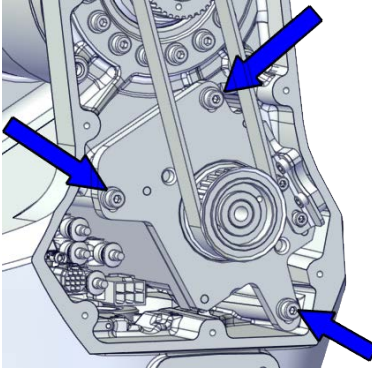
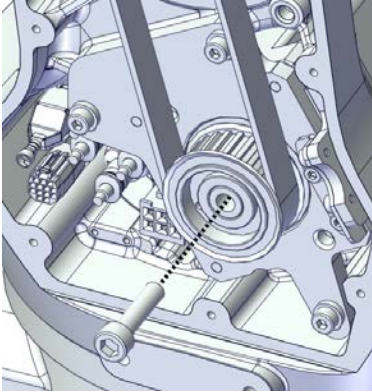

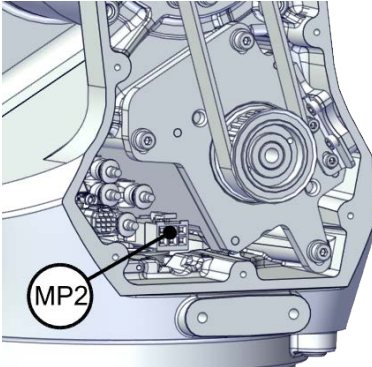
5.8.2 Replacing the axis-2 gearbox

Continued

	Action	Note
10	Secure the motor with the screws.	<p>Tightening torque: 3.5 Nm</p>  <p>xx1800002493</p>
11	Use a sonic tension meter to measure the timing belt tension.	<p>Used belt: 163-174 Hz New belt: 180-229 Hz (for reference only)</p>
12	If the timing belt tension does not meet the requirement, loosen the motor screws and readjust.	
13	Remove the adjustment screw from the motor.	 <p>xx1900000010</p>
14	<p>Reconnect the connector.</p> <ul style="list-style-type: none"> • MP2 <p> Tip</p> <p>See the number markings on the connectors for help to find the corresponding connector.</p>	 <p>xx1800002495</p>

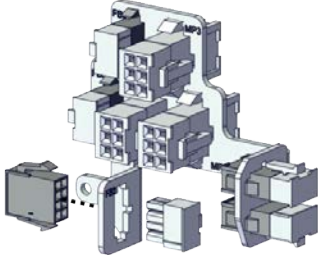
Continues on next page

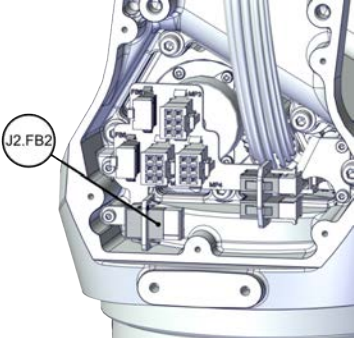
Reconnecting the connector at the division point

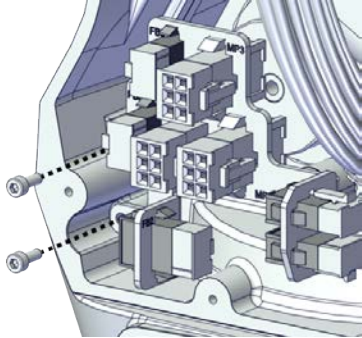
	Action	Note
1	<p>For robots with protection type Clean Room: Clean the joints that have been opened and wipe the parts free from particles with spirit on a lint free.</p>	
2	<p>Insert the female header of the connector to the connector plate.</p>	 <p>xx1800002491</p>
3	<p>Reconnect the connector.</p> <ul style="list-style-type: none"> J2.FB2 <p> Tip</p> <p>See the number markings on the connectors for help to find the corresponding connector.</p>	 <p>xx1800002490</p>
4	<p>Route and secure the cabling with cable straps.</p> <p> CAUTION</p> <p>Correct cable routing is highly important. If the cables are routed and secured incorrectly the cables can be damaged.</p>	
5	<p>Refit the connector plate.</p>	<p>Screw: M3x8 12.9 Lafre 2C2B/FC6.9 (2 pcs) Tightening torque: 0.8 Nm</p>  <p>xx1800002489</p>

Continues on next page

5 Repair

5.8.2 Replacing the axis-2 gearbox

Continued

Refitting the swing covers

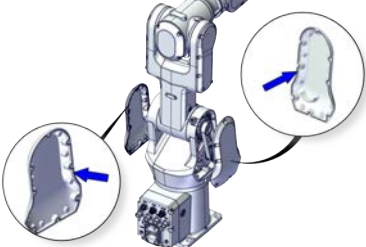
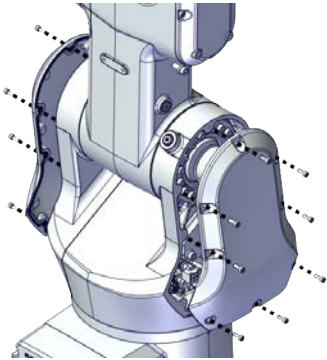
	Action	Note
1	For robots with protection type Clean Room: Clean the joints that have been opened and wipe the parts free from particles with spirit on a lint free.	
2	For robots with protection class IP67 (option 3350-670) For robots with protection type Clean Room (option 3351-4) Check the gaskets. Replace if damaged.	 xx1900002175
3	Apply grease to the cable package, cover all moving area of the package.	
4	Apply grease to the covers that have contacting area with the cable package.	
5	Refit the covers. <ul style="list-style-type: none"> • Swing cover • Swing support cover 	Screw: M3x8 12.9 Lafre 2C2B/FC6.9 Tightening torque: 1.2 Nm  xx1800003607

Concluding procedure

	Action	Note
1	For robots with protection type Clean Room: Clean and paint the joints that have been opened. See Cut the paint or surface on the robot before replacing parts on page 124  Note After all repair work, wipe the Clean Room robot free from particles with spirit on a lint free cloth.	
2	Recalibrate the robot.	Calibration is detailed in section Calibration on page 685 .

Continues on next page

	Action	Note
3	 DANGER Make sure all safety requirements are met when performing the first test run. See Test run after installation, maintenance, or repair on page 91 .	

5 Repair

5.8.3 Replacing the axis-3 gearbox

5.8.3 Replacing the axis-3 gearbox

Location of the axis-3 gearbox

The axis-3 gearbox is located as shown in the figure.

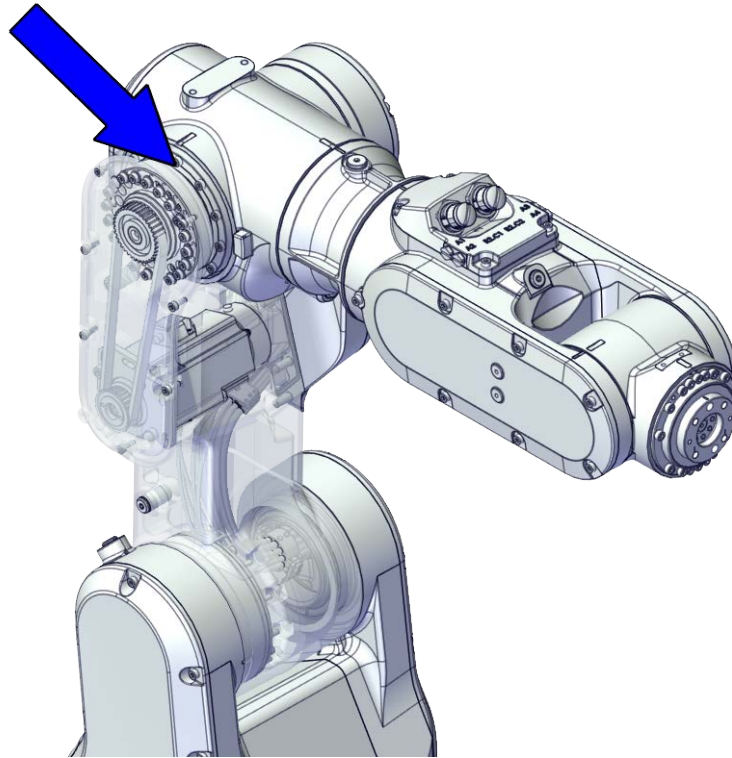

xx1800002480

Required spare parts



Note

The spare part numbers that are listed in the table can be out of date. See the latest spare parts of the IRB 1100 via myABB Business Portal, www.abb.com/myABB.

Spare part	Article number	Note
Gear unit with pulley, axis 3	3HAC073518-001	
Labyrinth sealing ring	3HAC073218-001	
O-ring on circular spline side	3HAC061327-009	Used with protection class IP67 and protection type Clean Room. Replace if damaged.
O-ring on flexible spline side	3HAC061327-008	Used with protection class IP67 and protection type Clean Room. Replace if damaged.
Axis-3 radial sealing	3HAB3701-57	Used with protection class IP67 and protection type Clean Room. Replace if damaged.

Continues on next page

5.8.3 Replacing the axis-3 gearbox

Continued

Spare part	Article number	Note
Motor with flange, axis 3	3HAC083587-001	
Timing belt, axis 3	3HAC061936-001	
Lower arm cover	3HAC069057-001	
Lower arm cover, Clean Room	3HAC075503-001	Used with protection type Clean Room.
Lower arm support cover	3HAC069059-001	
Lower arm support cover, Clean Room	3HAC075505-001	Used with protection type Clean Room.
Gasket for lower arm cover	3HAC061959-006	Used with protection class IP67 and protection type Clean Room. Replace if damaged.
Gasket for lower arm support cover	3HAC065331-001	Used with protection class IP67 and protection type Clean Room. Replace if damaged.
Cooling pad for axis-3 and -4 motors	3HAC071021-001	Cooling pads are wear parts. One cooling pad sheet includes 10 pieces of small pad. Replace if damaged with one piece each time.
Washer	3HAC063985-001	9x4.3x1, Steel

Required tools and equipment

Equipment	Article number	Note
Standard toolkit	-	Content is defined in section Standard toolkit on page 733 .
Calibration tool box, Axis Calibration	3HAC074119-001	Delivered as a set of calibration tools. Required if Axis Calibration is the valid calibration method for the robot. The tool box also includes a unique calibration pin for IRB 1100 to be fitted to the tool flange during calibration of axis 6.
24 VDC power supply	-	Used to release the motor brakes.
Sonic tension meter	-	Used for measuring the timing belt tension.
Dynamometer	-	Used for measuring the timing belt tension.

Required consumables

Consumable	Article number	Note
Cable straps	-	
Grease	3HAC029132-001	FM 222

Continues on next page

5 Repair

5.8.3 Replacing the axis-3 gearbox

Continued

Consumable	Article number	Note
Grease	-	Castrol Molub. Alloy 777-1 NG Used to lubricate bearings on the swing support and lower arm support.
Locking liquid	-	Loctite 2400 (or equivalent Loctite 243)

Deciding calibration routine

Decide which calibration routine to be used, based on the information in the table. Depending on which routine is chosen, action might be required prior to beginning the repair work of the robot, see the table.

	Action	Note
1	Decide which calibration routine to use for calibrating the robot. <ul style="list-style-type: none">Reference calibration. External cable packages (DressPack) and tools can stay fitted on the robot.Fine calibration. All external cable packages (DressPack) and tools must be removed from the robot.	 Note Calibrating axis 6 always requires tools to be removed from the mounting flange (also for reference calibration) since the mounting flange is used for installation of the calibration tool.
	If the robot is to be calibrated with reference calibration: Find previous reference values for the axis or create new reference values. These values are to be used after the repair procedure is completed, for calibration of the robot. If no previous reference values exist, and no new reference values can be created, then reference calibration is not possible.	Follow the instructions given in the reference calibration routine on the FlexPendant to create reference values. Creating new values requires possibility to move the robot. Read more about reference calibration for Axis Calibration in Reference calibration routine on page 696 .
	If the robot is to be calibrated with fine calibration: Remove all external cable packages (DressPack) and tools from the robot.	



Removing the gearbox

Use these procedures to remove the axis-3 gearbox.

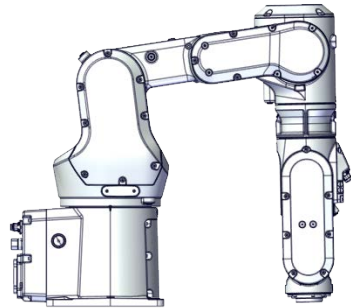

Preparations before removing the axis-3 gearbox

	Action	Note
1	Decide which calibration routine to use, and take actions accordingly prior to beginning the repair procedure.	

Continues on next page

	Action	Note
2	<p>Jog the robot to the specified position:</p> <ul style="list-style-type: none"> • Axis 1: 0° • Axis 2: 110° (IRB 1100-4/0.475) /95° (IRB 1100-4/0.58) • Axis 3: -20° (IRB 1100-4/0.475)/ -6° (IRB 1100-4/0.58) • Axis 4: 0° • Axis 5: 0° • Axis 6: No significance. 	 <p>xx1800003289</p>
3	<p> DANGER</p> <p>Turn off all:</p> <ul style="list-style-type: none"> • electric power supply • hydraulic pressure supply • air pressure supply <p>to the robot, before entering the safeguarded space.</p>	
4	<p> CAUTION</p> <p>For robots with protection type Clean Room Always cut the paint with a knife and grind the paint edge when disassembling parts of the robot! See Cut the paint or surface on the robot before replacing parts on page 124.</p>	

Disconnecting the axis-3 motor connectors





	Action	Note
1	<p> DANGER</p> <p>Make sure that all supplies for electrical power, hydraulic pressure, and air pressure are turned off.</p>	
2	<p> CAUTION</p> <p>For robots with protection type Clean Room Always cut the paint with a knife and grind the paint edge when disassembling parts of the robot! See Cut the paint or surface on the robot before replacing parts on page 124.</p>	

Continues on next page

5 Repair

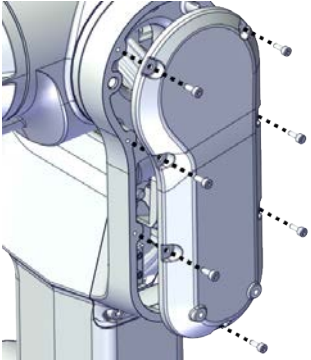

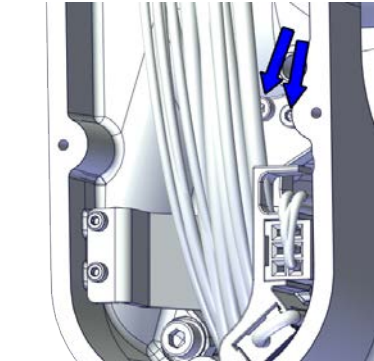

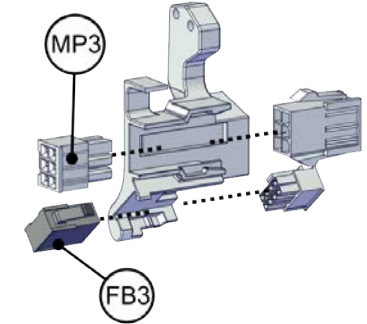
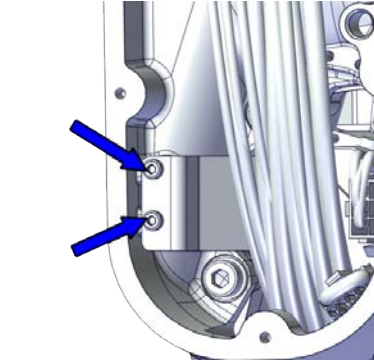
5.8.3 Replacing the axis-3 gearbox

Continued



	Action	Note
3	Remove the lower arm support cover.	 xx1800003003
4	Remove the connector plate.  CAUTION Be aware of the cabling that are attached to the connector plate! The connector plate cannot be removed completely until the connectors are removed from the plate, as shown in following step.	 xx1800003004
5	Slide the connectors out of the connector plate and disconnect the connectors. <ul style="list-style-type: none">• FB3• MP3  Tip Take photos of the connector and cable position before disconnecting them, to have as a reference when reconnecting.	 xx1800003005
6	Remove the cable bracket.	 xx1800003006

Continues on next page

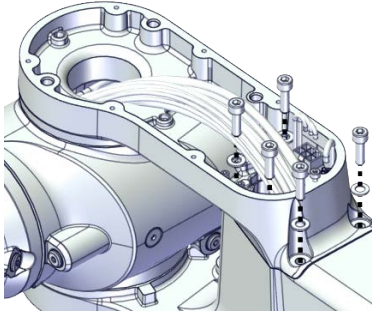
Loosening the lower arm support

	Action	Note
1	 DANGER Make sure that all supplies for electrical power, hydraulic pressure, and air pressure are turned off.	
2	 CAUTION For robots with protection type Clean Room Always cut the paint with a knife and grind the paint edge when disassembling parts of the robot! See Cut the paint or surface on the robot before replacing parts on page 124 .	
3	Loosen the lower arm support screws.  Tip If the lower arm support is hard to loosen from the housing, use a plastic hammer to knock on the lower arm support lightly.  CAUTION The support cannot be removed completely. Make sure the hanging support will not wear or damage the cable harness.	 <small>xx1800003286</small>

Loosening the axis-3 motor

	Action	Note
1	 DANGER Make sure that all supplies for electrical power, hydraulic pressure, and air pressure are turned off.	
2	 CAUTION For robots with protection type Clean Room Always cut the paint with a knife and grind the paint edge when disassembling parts of the robot! See Cut the paint or surface on the robot before replacing parts on page 124 .	
3	 CAUTION Loosening timing belts will release axes. This means the axes can fall down. Make sure axes are well supported before loosening timing belts.	

Continues on next page

5 Repair

5.8.3 Replacing the axis-3 gearbox



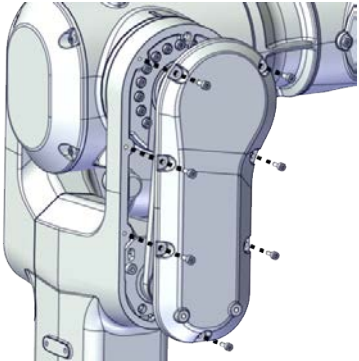
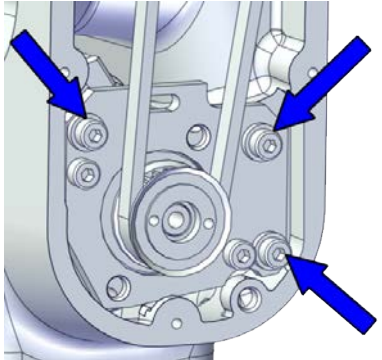
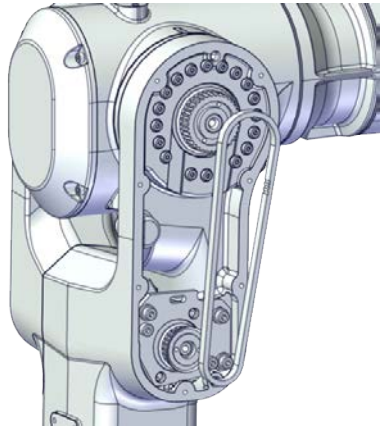

Continued

	Action	Note
4	Remove the lower arm cover.	 xx1800003007
5	Loosen the screws and move the motor slightly to slacken the timing belt.	 xx1800003008
6	Remove the timing belt from its grooves on the motor and gearbox.	 xx1800003022

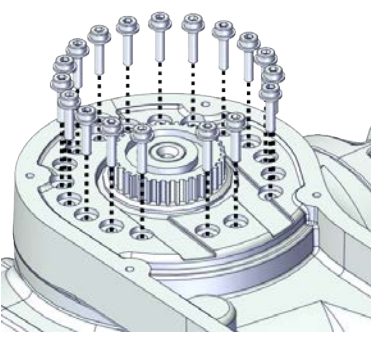

Separating the lower arm from the housing

	Action	Note
1	 DANGER Make sure that all supplies for electrical power, hydraulic pressure, and air pressure are turned off.	

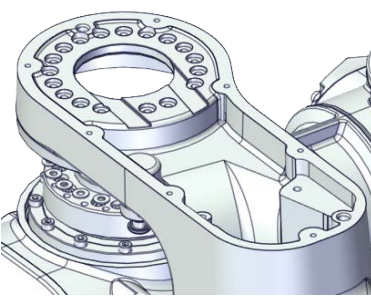
Continues on next page

	Action	Note
2	 CAUTION For robots with protection type Clean Room Always cut the paint with a knife and grind the paint edge when disassembling parts of the robot! See <i>Cut the paint or surface on the robot before replacing parts on page 124.</i>	
3	Remove the screws.  Note Some robots may be fitted with separate screws and washers. During replacement, always use the same screws (and washers) that are fitted on the robot at delivery. Contact ABB for more information.	 xx1900002190
4	Separate the lower arm from the housing.  Tip If the lower arm is hard to loosen from the housing, use a plastic hammer to knock on the lower arm lightly.	 xx1800003090

Removing the axis-3 gearbox

	Action	Note
1	 DANGER Make sure that all supplies for electrical power, hydraulic pressure, and air pressure are turned off.	
2	 CAUTION For robots with protection type Clean Room Always cut the paint with a knife and grind the paint edge when disassembling parts of the robot! See <i>Cut the paint or surface on the robot before replacing parts on page 124.</i>	

Continues on next page

5 Repair

5.8.3 Replacing the axis-3 gearbox

Continued

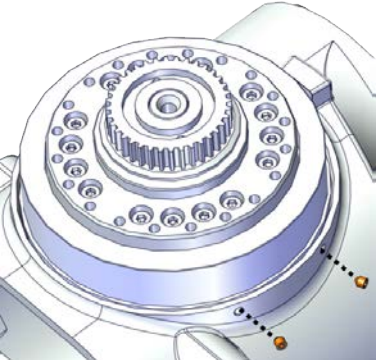
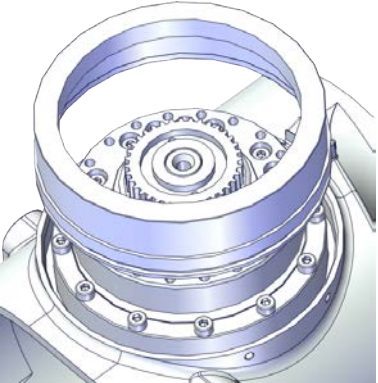
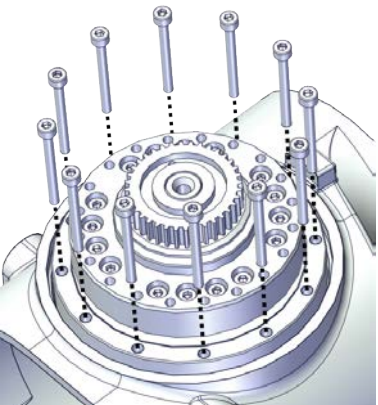
	Action	Note
3	<p> CAUTION</p> <p>Removing gearboxes will release axes. This means the axes can fall down.</p> <p>Make sure axes are well supported before removing gearboxes.</p>	
4	Remove the screws on the labyrinth sealing ring.	 <p>xx1900001425</p>
5	Remove the labyrinth sealing ring lightly and evenly.	 <p>xx1900001417</p>
6	Remove the screws.	 <p>xx1800003284</p>

Continues on next page

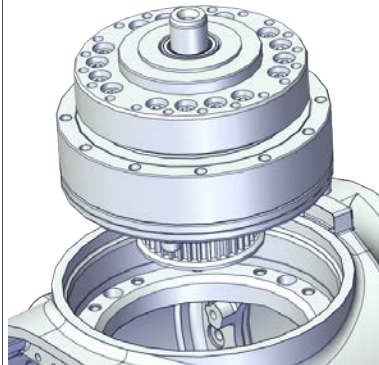
	Action	Note
7	Pull out the gearbox.	 <p data-bbox="1054 705 1165 728">xx1800003285</p>

Refitting the gearbox

Use these procedures to refit the axis-3 gearbox.

Refitting the axis-3 gearbox

	Action	Note
1	For robots with protection type Clean Room: Clean the joints that have been opened and wipe the parts free from particles with spirit on a lint free.	

Continues on next page

5 Repair

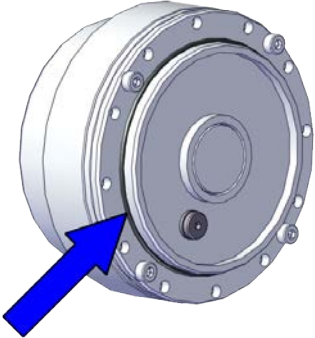
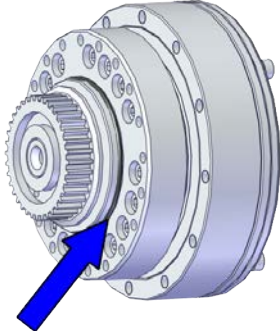
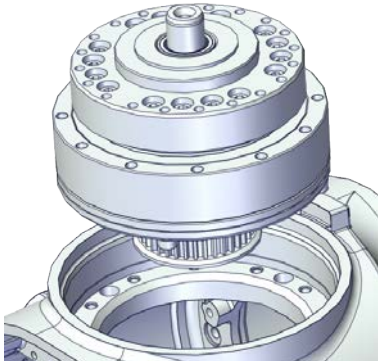

5.8.3 Replacing the axis-3 gearbox

Continued

	Action	Note
2	<p>For robots with protection class IP67 (option 3350-670) For robots with protection type Clean Room (option 3351-4) Check the O-rings. Replace if damaged.</p>	<p>O-ring on flexible spline side: 3HAC061327-008</p>  <p>xx1900002197</p> <p>O-ring on circular spline side: 3HAC061327-009</p>  <p>xx1900002196</p>
3	Refit the axis-3 gearbox.	 <p>xx1800003285</p>

Continues on next page

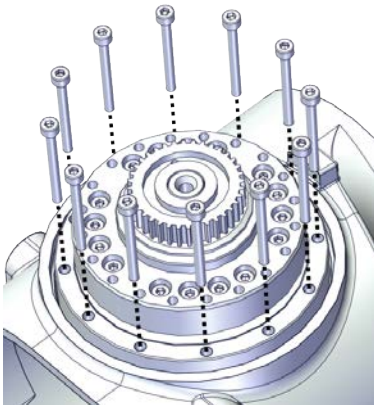
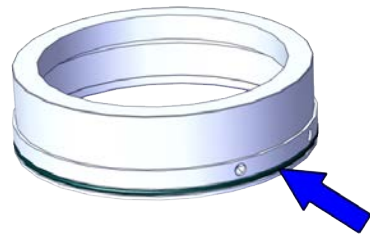
5.8.3 Replacing the axis-3 gearbox
Continued

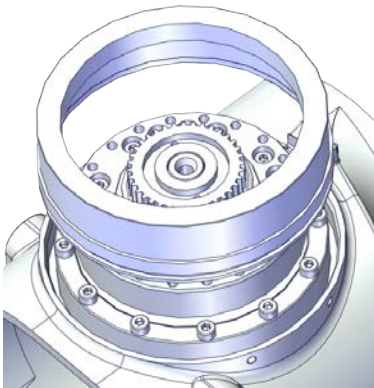
	Action	Note
4	Secure with screws.	<p>Screw: M3x30 12.9 Lafre 2C2B/FC6.9 (12 pcs) Tightening torque: 1.8 Nm</p>  <p>xx1800003284</p>
5	Check the O-ring. Replace if damaged.	 <p>xx1900001424</p>
6	<p>Refit the labyrinth sealing ring lightly and evenly.</p> <p> Note Make sure the labyrinth sealing ring is well fitted to the axis-3 gearbox without any deflection.</p>	 <p>xx1900001417</p>

Continues on next page

5 Repair

5.8.3 Replacing the axis-3 gearbox

Continued

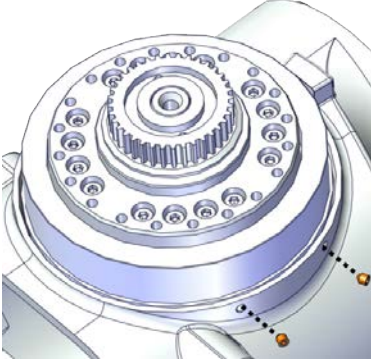
	Action	Note
7	Apply a little Loctite 243 to the screws and secure the labyrinth sealing ring with the screws.	<p>Screw: M3x4 (2 pcs) Tightening torque: 0.8 Nm</p>  <p>xx1900001425</p>

Refitting the lower arm to the housing

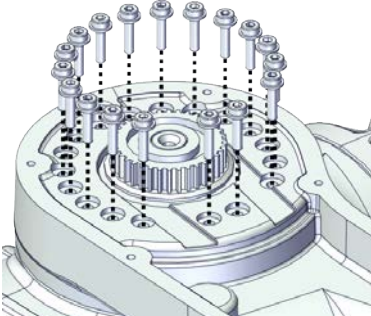
	Action	Note
1	For robots with protection type Clean Room: Clean the joints that have been opened and wipe the parts free from particles with spirit on a lint free.	
2	<p>Refit the lower arm to the housing.</p> <p> Note</p> <p>Some robots may be fitted with separate screws and washers. During replacement, always use the same screws (and washers) that are fitted on the robot at delivery. Contact ABB for more information.</p>	<p>Flange screws (16 pcs) For robots with protection class IP40 Tightening torque: 1.9 Nm For robots with protection class IP67 For robots with protection type Clean Room Tightening torque: 1.8 Nm</p>  <p>xx1900002190</p>

Checking the radial sealing on the lower arm support (IP67 or Clean Room)

	Action	Note
1	For robots with protection type Clean Room: Clean the joints that have been opened and wipe the parts free from particles with spirit on a lint free.	

Continues on next page

5.8.3 Replacing the axis-3 gearbox
Continued

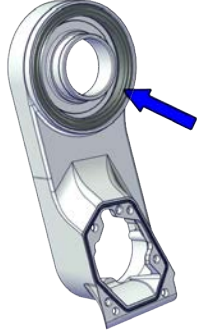
	Action	Note
2	Check the radial sealing on the lower arm support.	 <p>xx1900002202</p>
3	Replace the radial sealing if damaged. The lower arm support must be removed completely before the radial sealing can be removed. See Replacing the lower arm on page 333 .	Axis-3 radial sealing assembly tool, included in the radial sealing assembly tool set 3HAC074609-001.

Securing the lower arm support

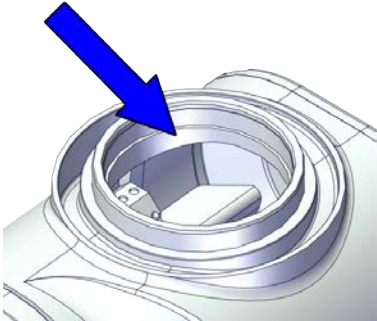
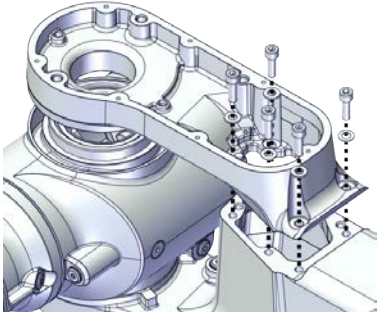
	Action	Note
1	For robots with protection type Clean Room: Clean the joints that have been opened and wipe the parts free from particles with spirit on a lint free.	
2	Apply grease Castrol Molub-Alloy 777-1 NG to the inner surface of the housing, where contacts the bearing on the lower arm support.	 <p>xx2000000059</p>
3	Refit the lower arm support.	<p>Screw: M5x16 12.9 Lafre 2C2B/FC6.9 (5 pcs) Tightening torque: 8 Nm</p>  <p>xx1800003088</p>

Continues on next page



5 Repair

5.8.3 Replacing the axis-3 gearbox

Continued

	Action	Note
4	Route the cable package through the lower arm support.	

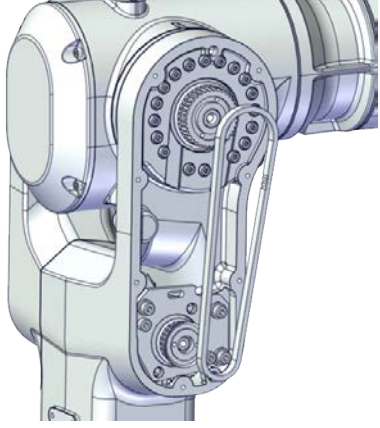
Securing the axis-3 motor

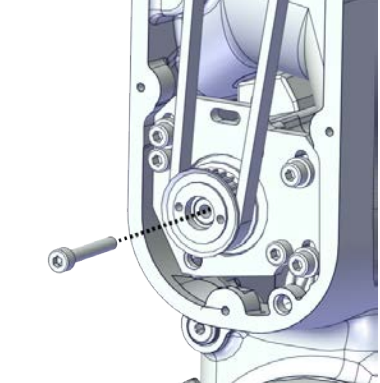
	Action	Note
1	For robots with protection type Clean Room: Clean the joints that have been opened and wipe the parts free from particles with spirit on a lint free.	
2	Install the timing belt to the pulleys and verify that the belt runs correctly in the grooves of the pulleys.	 xx1800003022
3	Install an M4x25 or longer adjustment screw to the motor.  Note Do not insert the entire screw to the hole.	 xx1900000009

Continues on next page

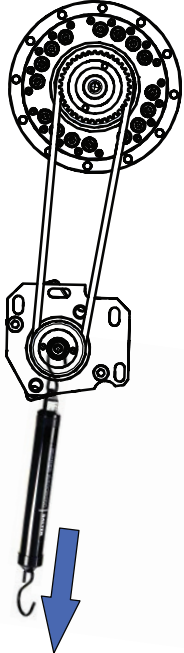
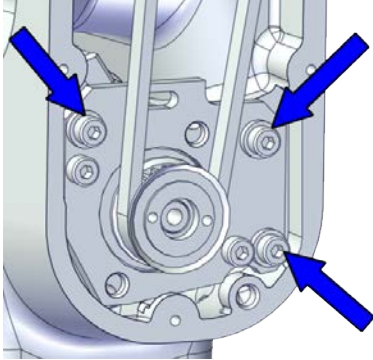
	Action	Note
4	Use a handheld dynamometer hooking to the screw and pull the dynamometer to reach the initial referenced force.	<p>Initial referenced force for used belt: 21.7-23.94 N (for reference only) Initial referenced force for new belt: 31-34.2 N</p>  <p>xx1900000028</p>
5	Secure the motor with the screws.	<p>Screw: M4x12 12.9 Lafre 2C2B/FC6.9 (3 pcs) Washer, 3HAC063985-001 (3 pcs) Tightening torque: 3 Nm</p>  <p>xx1800003008</p>
6	Use a sonic tension meter to measure the timing belt tension.	<p>Used belt: 102-109 Hz New belt: 113-143 Hz (for reference only)</p>
7	If the timing belt tension does not meet the requirement, loosen the motor screws and readjust.	

Continues on next page



5 Repair

5.8.3 Replacing the axis-3 gearbox

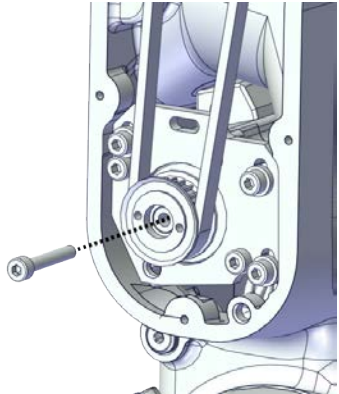
Continued

	Action	Note
8	Remove the adjustment screw from the motor.	 <p data-bbox="1027 714 1134 734">xx190000009</p>

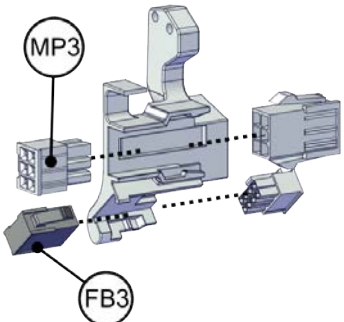
Reconnecting the axis-3 motor connectors

	Action	Note
1	For robots with protection type Clean Room: Clean the joints that have been opened and wipe the parts free from particles with spirit on a lint free.	
2	Slide the connectors into the connector plate and reconnect the connectors. <ul style="list-style-type: none"> • FB3 • MP3  Tip See the number markings on the connectors for help to find the corresponding connector.	 <p data-bbox="1027 1384 1134 1404">xx1800003005</p>
3	Route and secure the cabling with cable straps.  CAUTION Correct cable routing is highly important. If the cables are routed and secured incorrectly the cables can be damaged.	

Continues on next page

5.8.3 Replacing the axis-3 gearbox

Continued

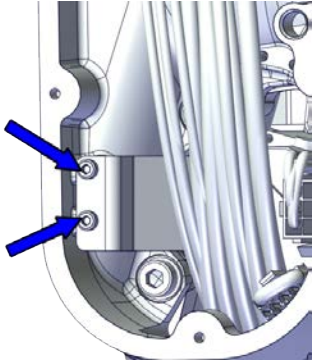
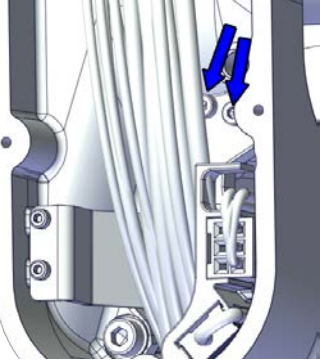
	Action	Note
4	Refit the cable bracket.	<p>Screw: M2.5x6 12.9 Lafre 2C2B/FC6.9 (2 pcs) Tightening torque: 0.6 Nm</p>  <p>xx1800003006</p>
5	Refit the connector plate.	<p>Screw: M3x12 12.9 Lafre 2C2B/FC6.9 (2 pcs) Tightening torque: 0.4 Nm</p>  <p>xx1800003004</p>

Refitting the lower arm covers

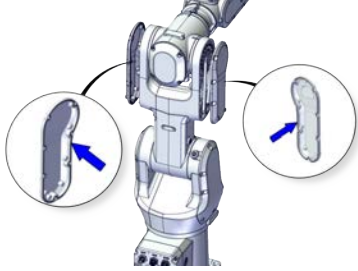
	Action	Note
1	For robots with protection type Clean Room: Clean the joints that have been opened and wipe the parts free from particles with spirit on a lint free.	
2	<p>For robots with protection class IP67 (option 3350-670) For robots with protection type Clean Room (option 3351-4) Check the gaskets. Replace if damaged.</p>	 <p>xx1900002179</p>
3	Apply grease to the cable package, cover all moving area of the package.	

Continues on next page



5 Repair

5.8.3 Replacing the axis-3 gearbox

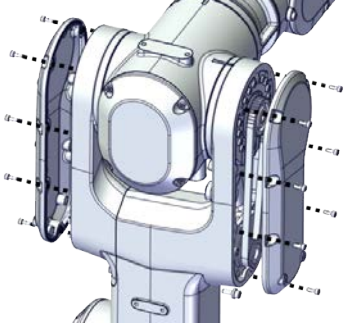
Continued

	Action	Note
4	Apply grease to the covers that have contacting area with the cable package.	
5	Refit the covers. <ul style="list-style-type: none"> • Lower arm cover • Lower arm support cover 	Screw: M3x8 12.9 Lafre 2C2B/FC6.9 Tightening torque: 1.2 Nm  xx1800003608

Concluding procedure

	Action	Note
1	For robots with protection type Clean Room: Clean and paint the joints that have been opened. See Cut the paint or surface on the robot before replacing parts on page 124  Note After all repair work, wipe the Clean Room robot free from particles with spirit on a lint free cloth.	
2	Recalibrate the robot.	Calibration is detailed in section Calibration on page 685 .
3	 DANGER Make sure all safety requirements are met when performing the first test run. See Test run after installation, maintenance, or repair on page 91 .	

5.8.4 Replacing the axis-4 gearbox

Location of the axis-4 gearbox

The axis-4 gearbox is located as shown in the figure.

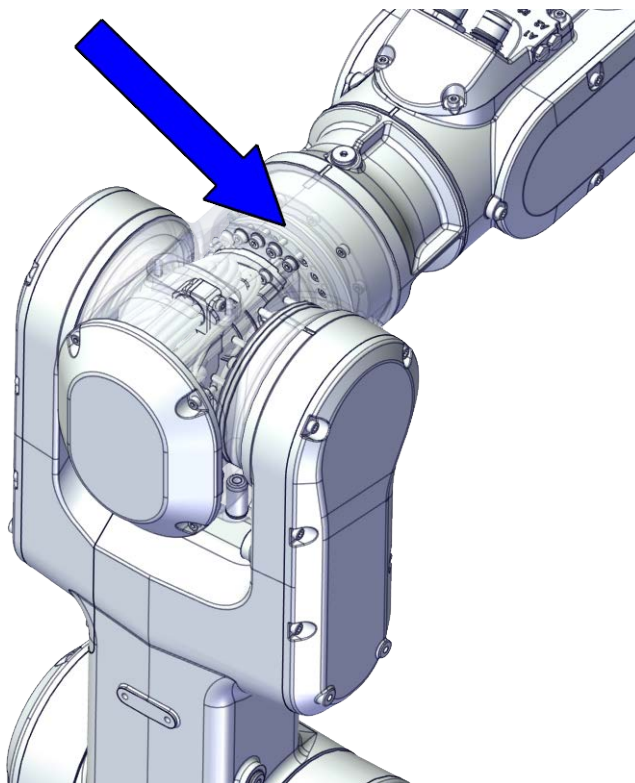

xx1800002481

Required spare parts



Note

The spare part numbers that are listed in the table can be out of date. See the latest spare parts of the IRB 1100 via myABB Business Portal, www.abb.com/myABB.

Spare part	Article number	Note
Lower cable harness, basic	3HAC075521-001	Used with protection classes IP40 and IP67.
Lower cable harness, basic, Clean Room	3HAC075514-001	Used with protection type Clean Room.
Lower cable harness (CP/CS and air hose, without Ethernet)	3HAC075522-001	Used with protection classes IP40 and IP67.
Lower cable harness, Clean Room (CP/CS and air hose, without Ethernet)	3HAC075515-001	Used with protection type Clean Room.
Lower cable harness (CP/CS and air hose, with Ethernet)	3HAC075523-001	Used with protection classes IP40 and IP67.

Continues on next page

5 Repair

5.8.4 Replacing the axis-4 gearbox

Continued

Spare part	Article number	Note
Lower cable harness, Clean Room (CP/CS and air hose, with Ethernet)	3HAC075581-001	Used with protection type Clean Room.
Gear unit with pulley, axis 4	3HAC073519-001	
O-ring on circular spline side	3HAC061327-009	Used with protection class IP67 and protection type Clean Room. Replace if damaged.
O-ring on flexible spline side	3HAB3772-115	Used with protection class IP67 and protection type Clean Room. Replace if damaged.
Motor with flange, axis 4	3HAC083586-001	
Timing belt, axis 4	3HAC061937-001	
Motor with flange, axis 6	3HAC083584-001	
Timing belt, axis 6	3HAC061939-001	
Housing cover	3HAC069054-001	
Housing cover, Clean Room	3HAC075501-001	Used with protection type Clean Room.
Wrist cover	3HAC069061-001	
Wrist cover, Clean Room	3HAC075507-001	Used with protection type Clean Room.
Gasket for housing cover	3HAC061959-007	Used with protection class IP67 and protection type Clean Room. Replace if damaged.
Gasket for wrist cover	3HAC061959-009	Used with protection class IP67 and protection type Clean Room. Replace if damaged.
Cooling pad for axis-3 and -4 motors	3HAC071021-001	Cooling pads are wear parts. One cooling pad sheet includes 10 pieces of small pad. Replace if damaged with one piece each time.
Washer	3HAC064765-001	7x3.2x1.5, Steel
Rubber sealing washer on housing	3HAC064147-001	Used with protection class IP67 and protection type Clean Room. Replace if damaged.
Rubber sealing washer on extender unit	3HAC067995-001	Used with protection class IP67 and protection type Clean Room. Replace if damaged.
Plug screw	3HAC064146-001	Used with protection classes IP40 and IP67. Replace if damaged.
Plug screw, Clean Room	3HAC070309-001	Used with protection type Clean Room. Replace if damaged.

Continues on next page

Required tools and equipment

Equipment	Article number	Note
Standard toolkit	-	Content is defined in section Standard toolkit on page 733 .
Calibration tool box, Axis Calibration	3HAC074119-001	Delivered as a set of calibration tools. Required if Axis Calibration is the valid calibration method for the robot. The tool box also includes a unique calibration pin for IRB 1100 to be fitted to the tool flange during calibration of axis 6.
24 VDC power supply	-	Used to release the motor brakes.
M3x25 eye bolt	-	Included in the special toolkit 3HAC071022-001.
Dynamometer	-	Used for measuring the timing belt tension.
J5.C2 connector assembly tool	-	Included in the special toolkit 3HAC071022-001. Used to remove and refit the J5.C2 connector, if the Ethernet cabling is equipped.
axis-4 motor fitting tool	-	Included in the special toolkit 3HAC071022-001. Used to refit the axis-4 motor.

Required consumables

Consumable	Article number	Note
Cable straps	-	
Grease	3HAC029132-001	FM 222
Locking liquid	-	Loctite 2400 (or equivalent Loctite 243)

Deciding calibration routine

Decide which calibration routine to be used, based on the information in the table. Depending on which routine is chosen, action might be required prior to beginning the repair work of the robot, see the table.

	Action	Note
1	Decide which calibration routine to use for calibrating the robot. <ul style="list-style-type: none"> Reference calibration. External cable packages (DressPack) and tools can stay fitted on the robot. Fine calibration. All external cable packages (DressPack) and tools must be removed from the robot. 	 Note Calibrating axis 6 always requires tools to be removed from the mounting flange (also for reference calibration) since the mounting flange is used for installation of the calibration tool.

Continues on next page

5 Repair

5.8.4 Replacing the axis-4 gearbox



Continued

Action	Note
<p>If the robot is to be calibrated with reference calibration: Find previous reference values for the axis or create new reference values. These values are to be used after the repair procedure is completed, for calibration of the robot. If no previous reference values exist, and no new reference values can be created, then reference calibration is not possible.</p>	<p>Follow the instructions given in the reference calibration routine on the FlexPendant to create reference values. Creating new values requires possibility to move the robot. Read more about reference calibration for Axis Calibration in Reference calibration routine on page 696.</p>
<p>If the robot is to be calibrated with fine calibration: Remove all external cable packages (DressPack) and tools from the robot.</p>	

Removing the gearbox

Use these procedures to remove the axis-4 gearbox.

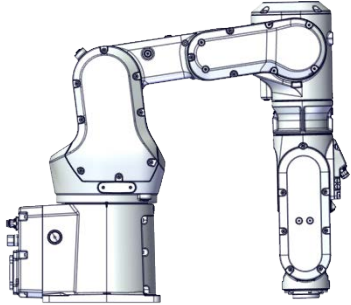

Preparations before removing the axis-4 gearbox

	Action	Note
1	Decide which calibration routine to use, and take actions accordingly prior to beginning the repair procedure.	
2	<p>Jog the robot to the specified position:</p> <ul style="list-style-type: none"> • Axis 1: 0° • Axis 2: 110° (IRB 1100-4/0.475) /95° (IRB 1100-4/0.58) • Axis 3: -20° (IRB 1100-4/0.475)/ -6° (IRB 1100-4/0.58) • Axis 4: 0° • Axis 5: 0° • Axis 6: No significance. 	 <p>xx1800003289</p>
3	<p> DANGER</p> <p>Turn off all:</p> <ul style="list-style-type: none"> • electric power supply • hydraulic pressure supply • air pressure supply <p>to the robot, before entering the safeguarded space.</p>	

Continues on next page

	Action	Note
4	 CAUTION For robots with protection type Clean Room Always cut the paint with a knife and grind the paint edge when disassembling parts of the robot! See <i>Cut the paint or surface on the robot before replacing parts on page 124.</i>	

Removing the process hub

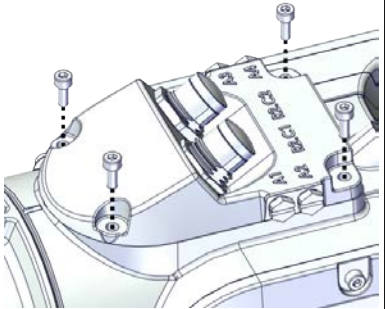
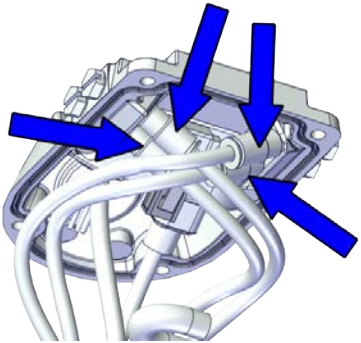
	Action	Note
1	 DANGER Make sure that all supplies for electrical power, hydraulic pressure, and air pressure are turned off.	
2	 CAUTION For robots with protection type Clean Room Always cut the paint with a knife and grind the paint edge when disassembling parts of the robot! See <i>Cut the paint or surface on the robot before replacing parts on page 124.</i>	
3	Remove the screws and carefully open the cover.  CAUTION Be aware of the cabling that is attached to the cover! The cover can not be removed completely until the connectors are disconnected, as shown in following steps.	 <p>xx1800002944</p>
4	Disconnect the air hoses.	 <p>xx1800002945</p>

Continues on next page



5 Repair

5.8.4 Replacing the axis-4 gearbox

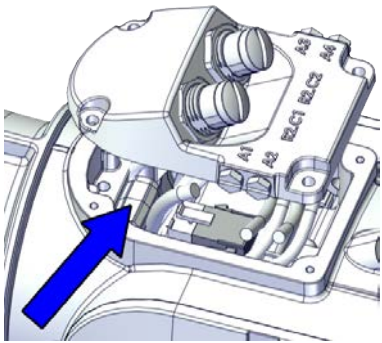
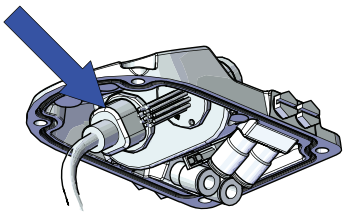
Continued

	Action	Note
5	<p>For robots with CP/CS cabling</p> <p>Disconnect the connector.</p> <ul style="list-style-type: none"> J5.C1 	 <p>xx1800002947</p>
6	<p>For robots with Ethernet cabling</p> <p>Disconnect the connector J5.C2 using the tool.</p>	<p>J5.C2 connector assembly tool: -</p>  <p>xx1800002948</p>



Removing the wrist covers

	Action	Note
1	 <p>DANGER</p> <p>Make sure that all supplies for electrical power, hydraulic pressure, and air pressure are turned off.</p>	
2	 <p>CAUTION</p> <p>For robots with protection type Clean Room</p> <p>Always cut the paint with a knife and grind the paint edge when disassembling parts of the robot! See Cut the paint or surface on the robot before replacing parts on page 124.</p>	

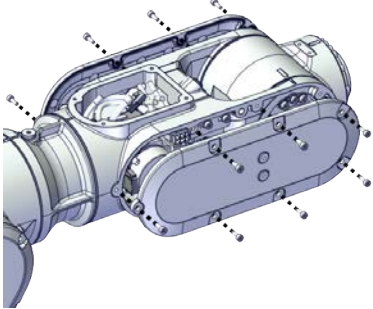
Continues on next page

	Action	Note
3	Remove the wrist covers from both sides.	 <p data-bbox="1059 674 1166 696">xx1800002949</p>

Disconnecting the axis-5 motor connectors

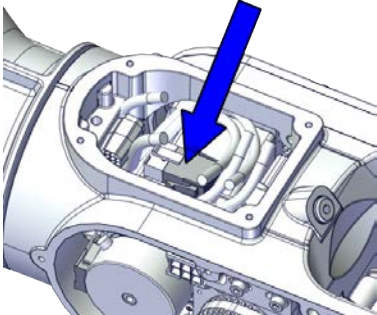
	Action	Note
1	 <p data-bbox="603 875 708 902">DANGER</p> <p data-bbox="512 936 1037 1014">Make sure that all supplies for electrical power, hydraulic pressure, and air pressure are turned off.</p>	
2	 <p data-bbox="603 1084 708 1111">CAUTION</p> <p data-bbox="512 1137 1046 1272">For robots with protection type Clean Room Always cut the paint with a knife and grind the paint edge when disassembling parts of the robot! See Cut the paint or surface on the robot before replacing parts on page 124.</p>	
3	Access the connector FB5 from the process hub and disconnect the connector.	 <p data-bbox="1059 1675 1166 1697">xx1800002950</p>

Continues on next page



5 Repair

5.8.4 Replacing the axis-4 gearbox

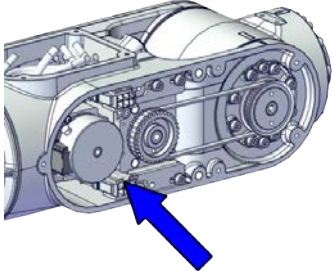
Continued

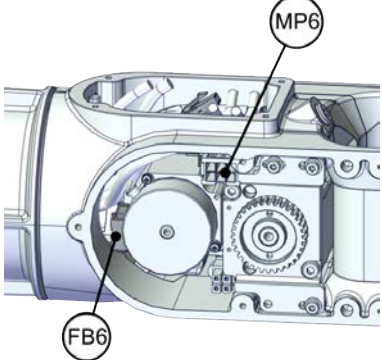

	Action	Note
4	Disconnect the connector. <ul style="list-style-type: none"> MP5 	 <p>xx1800002993</p>

Disconnecting the axis-6 motor connectors

	Action	Note
1	 DANGER Make sure that all supplies for electrical power, hydraulic pressure, and air pressure are turned off.	
2	 CAUTION For robots with protection type Clean Room Always cut the paint with a knife and grind the paint edge when disassembling parts of the robot! See Cut the paint or surface on the robot before replacing parts on page 124.	
3	Disconnect the connectors. <ul style="list-style-type: none"> MP6 FB6 	 <p>xx1800002994</p>

Continues on next page

Removing the axis-6 motor

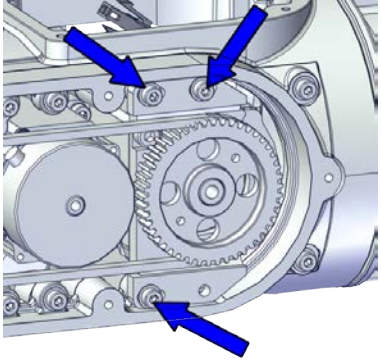
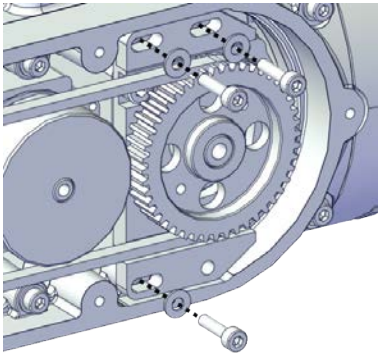
	Action	Note
1	 DANGER Make sure that all supplies for electrical power, hydraulic pressure, and air pressure are turned off.	
2	 CAUTION For robots with protection type Clean Room Always cut the paint with a knife and grind the paint edge when disassembling parts of the robot! See <i>Cut the paint or surface on the robot before replacing parts on page 124.</i>	
3	 CAUTION Removing motors will release axes. This means the axes can fall down. Make sure axes are well supported before removing motors.	
4	Loosen the screws and move the motor slightly to slacken the timing belt.	 <p>xx1800002995</p>
5	Remove the screws and washers.	 <p>xx1800002996</p>
6	Carefully lift out the motor.	

Continues on next page



5 Repair

5.8.4 Replacing the axis-4 gearbox

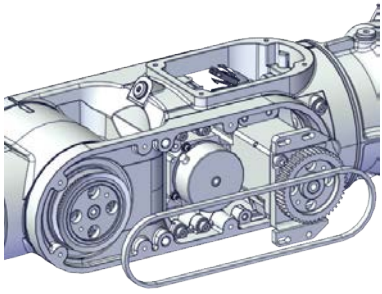
Continued

	Action	Note
7	Remove the timing belt from its groove on the motor.	 <p>xx1800002997</p>

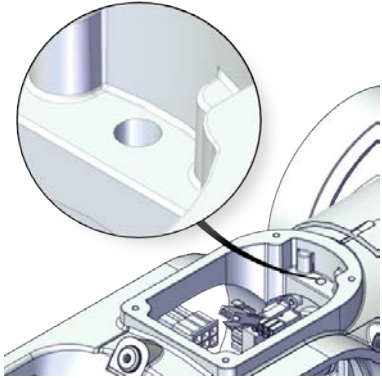

Loosening the cable package from axis-4 gearbox

	Action	Note
1	 DANGER Make sure that all supplies for electrical power, hydraulic pressure, and air pressure are turned off.	
2	 CAUTION For robots with protection type Clean Room Always cut the paint with a knife and grind the paint edge when disassembling parts of the robot! See Cut the paint or surface on the robot before replacing parts on page 124.	
3	Valid for IRB 1100-4/0.475 Access the cable package locking screw on the axis-4 gearbox from the wrist and then loosen the locking screw.	 <p>xx1800003031</p>

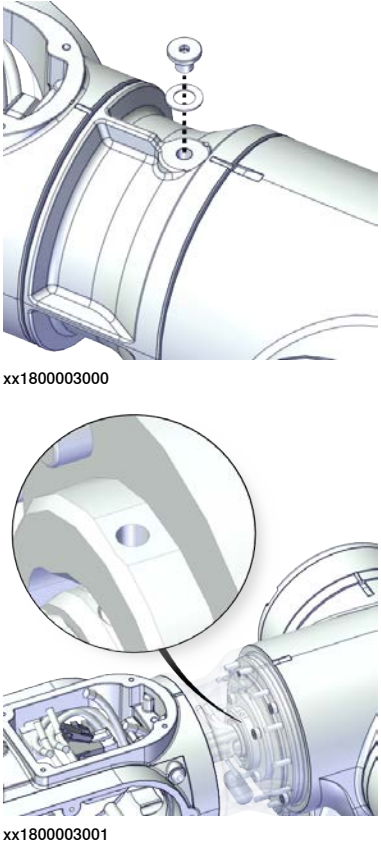
Continues on next page

	Action	Note
4	Remove the plug screw and washer on the extender unit to access the cable package locking screw on the axis-4 gearbox and then loosen the locking screw.	 <p>xx1800003000</p> <p>xx1800003001</p>

Disconnecting the axis-4 motor connectors

	Action	Note
1	 <p>DANGER</p> <p>Make sure that all supplies for electrical power, hydraulic pressure, and air pressure are turned off.</p>	
2	 <p>CAUTION</p> <p>For robots with protection type Clean Room Always cut the paint with a knife and grind the paint edge when disassembling parts of the robot! See Cut the paint or surface on the robot before replacing parts on page 124.</p>	

Continues on next page



5 Repair

5.8.4 Replacing the axis-4 gearbox

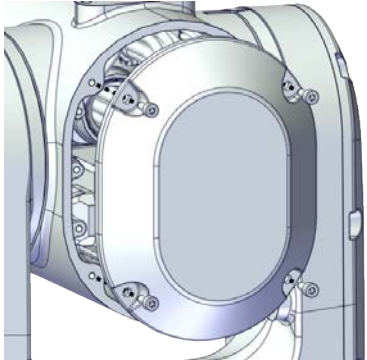
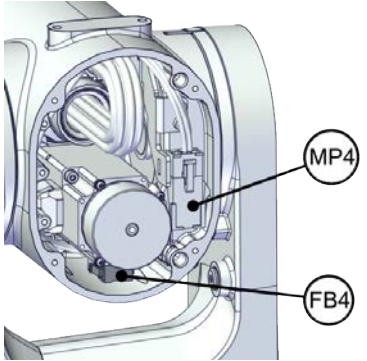
Continued



	Action	Note
3	Remove the housing cover.	 xx1800003011
4	Disconnect the motor connectors. <ul style="list-style-type: none"> • FB4 • MP4 	 xx1800003012

Pulling out the upper cable harness

	Action	Note
1	 DANGER Make sure that all supplies for electrical power, hydraulic pressure, and air pressure are turned off.	
2	 CAUTION For robots with protection type Clean Room Always cut the paint with a knife and grind the paint edge when disassembling parts of the robot! See Cut the paint or surface on the robot before replacing parts on page 124.	
3	Pull out the upper cable harness from the housing.	

Continues on next page

Removing the axis-4 motor

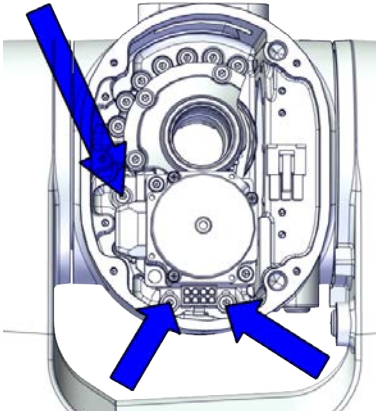
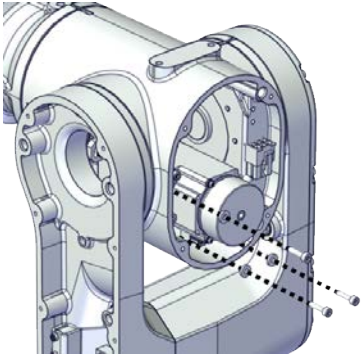
	Action	Note
1	 <p>DANGER</p> <p>Make sure that all supplies for electrical power, hydraulic pressure, and air pressure are turned off.</p>	
2	 <p>CAUTION</p> <p>For robots with protection type Clean Room Always cut the paint with a knife and grind the paint edge when disassembling parts of the robot! See <i>Cut the paint or surface on the robot before replacing parts on page 124.</i></p>	
3	 <p>CAUTION</p> <p>Removing motors will release axes. This means the axes can fall down. Make sure axes are well supported before removing motors.</p>	
4	<p>Loosen the screws and move the motor slightly to slacken the timing belt.</p>	 <p>xx1800003094</p>
5	<p>Remove the screws and washers.</p>	 <p>xx1800003095</p>

Continues on next page



5 Repair

5.8.4 Replacing the axis-4 gearbox

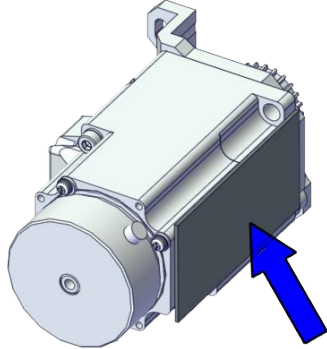
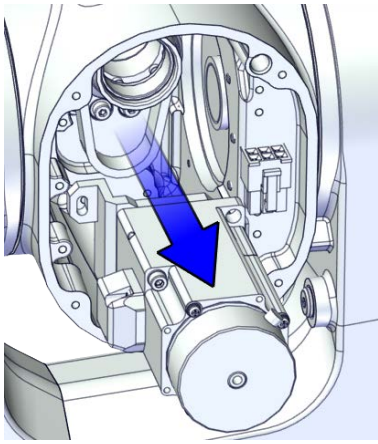
Continued

	Action	Note
6	<p>Carefully lift out the motor.</p> <p> CAUTION</p> <p>A cooling pad is attached to the motor, which may stick to the casting. Always use a plastic sheet with caution to remove the pad from the casting. Pay attention not to scratch the casting or damage the pad.</p>	<p>Cooling pad location</p>  <p>xx1800003605</p>
7	<p>Remove the timing belt from its groove on the motor.</p>	 <p>xx1800003096</p>



Removing the pulley cover and axis-4 timing belt

	Action	Note
1	<p> DANGER</p> <p>Make sure that all supplies for electrical power, hydraulic pressure, and air pressure are turned off.</p>	
2	<p> CAUTION</p> <p>For robots with protection type Clean Room</p> <p>Always cut the paint with a knife and grind the paint edge when disassembling parts of the robot! See Cut the paint or surface on the robot before replacing parts on page 124.</p>	

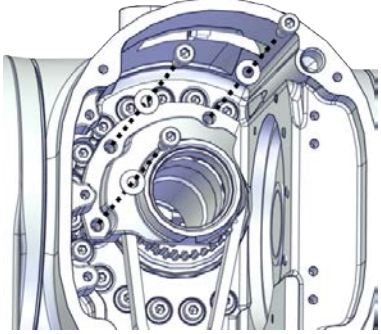
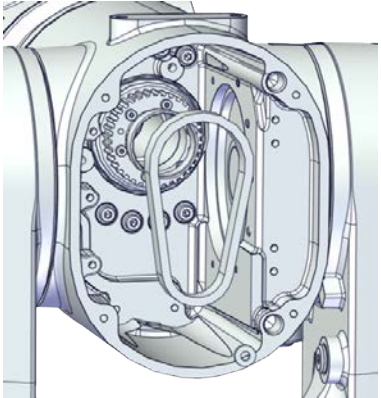
Continues on next page

	Action	Note
3	 CAUTION Loosening timing belts will release axes. This means the axes can fall down. Make sure axes are well supported before loosening timing belts.	
4	Remove the pulley cover.	 <p data-bbox="1059 891 1166 913">xx1800003097</p>
5	Remove the timing belt from its groove on the gearbox.	 <p data-bbox="1059 1344 1166 1366">xx1800003098</p>

Separating the housing

	Action	Note
1	 DANGER Make sure that all supplies for electrical power, hydraulic pressure, and air pressure are turned off.	
2	 CAUTION For robots with protection type Clean Room Always cut the paint with a knife and grind the paint edge when disassembling parts of the robot! See <i>Cut the paint or surface on the robot before replacing parts on page 124.</i>	

Continues on next page

5 Repair

5.8.4 Replacing the axis-4 gearbox

Continued

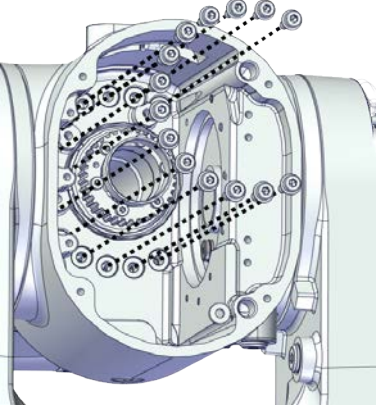
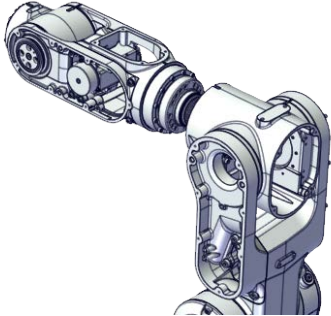
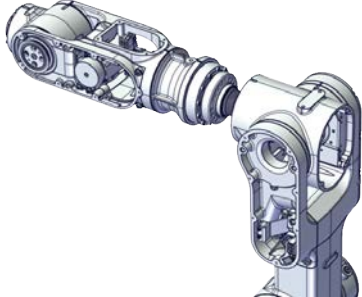

	Action	Note
3	<p>Remove the screws.</p> <p> Note</p> <p>Some robots may be fitted with separate screws and washers. During replacement, always use the same screws (and washers) that are fitted on the robot at delivery. Contact ABB for more information.</p>	 <p>xx1900002191</p>
4	<p>Valid for IRB 1100-4/0.475</p> <p>Separate the wrist from the housing.</p>	 <p>xx1800003075</p>
5	<p>Separate the extender unit and wrist from the housing.</p>	 <p>xx1800003100</p>

Removing the axis-4 gearbox

	Action	Note
1	<p> DANGER</p> <p>Make sure that all supplies for electrical power, hydraulic pressure, and air pressure are turned off.</p>	

Continues on next page

5.8.4 Replacing the axis-4 gearbox
Continued

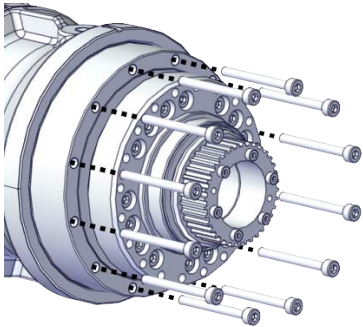
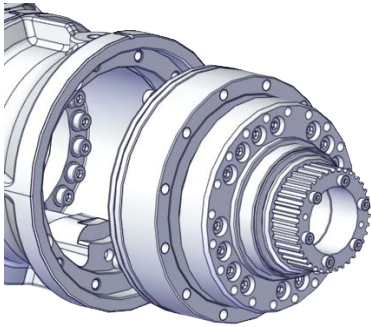
	Action	Note
2	<p> CAUTION</p> <p>For robots with protection type Clean Room Always cut the paint with a knife and grind the paint edge when disassembling parts of the robot! See <i>Cut the paint or surface on the robot before replacing parts on page 124.</i></p>	
3	<p> CAUTION</p> <p>Removing gearboxes will release axes. This means the axes can fall down. Make sure axes are well supported before removing gearboxes.</p>	
4	Remove the screws.	 <p>xx1800003300</p>
5	Pull out the gearbox.	 <p>xx1800003310</p>

Refitting the gearbox

Use these procedures to refit the axis-4 gearbox.

Refitting the axis-4 gearbox

	Action	Note
1	<p>For robots with protection type Clean Room: Clean the joints that have been opened and wipe the parts free from particles with spirit on a lint free.</p>	

Continues on next page

5 Repair

5.8.4 Replacing the axis-4 gearbox

Continued

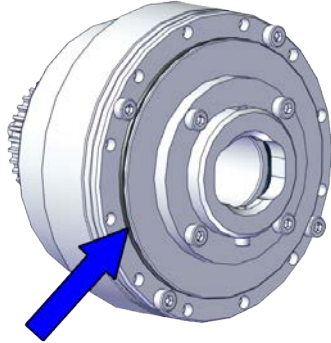
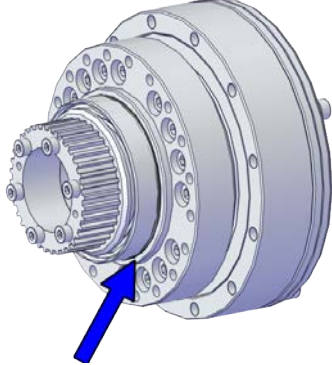
	Action	Note
2	<p>For robots with protection class IP67 (option 3350-670) For robots with protection type Clean Room (option 3351-4) Check the O-rings. Replace if damaged.</p>	<p>O-ring on flexible spline side: 3HAB3772-115</p>  <p>xx1900002199</p> <p>O-ring on circular spline side: 3HAC061327-009</p>  <p>xx1900002198</p>

Continues on next page

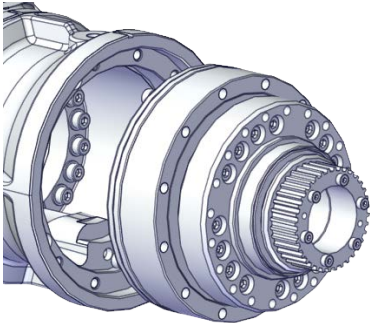
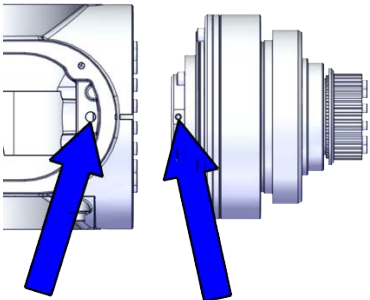
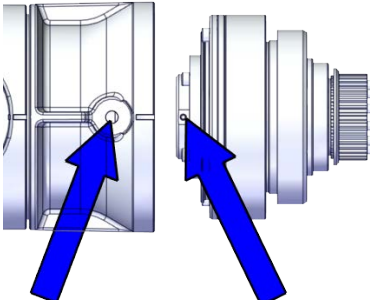
	Action	Note
3	<p>Refit the axis-4 gearbox. Make sure the locking screw holes on the gearbox and extender unit or wrist are aligned with each other.</p>	 <p>xx1800003310</p> <p>Valid for IRB 1100-4/0.475</p>  <p>xx1800003313</p>  <p>xx1800003312</p>

Continues on next page

5 Repair

5.8.4 Replacing the axis-4 gearbox

Continued

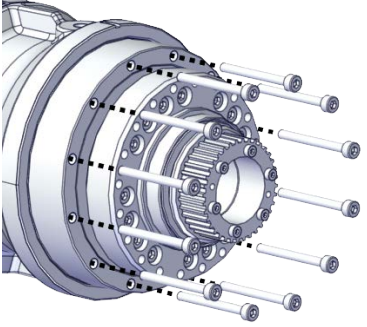
	Action	Note
4	Secure with screws.	<p>Screw: M3x30 12.9 Lafre 2C2B/FC6.9 (12 pcs) Tightening torque: 1.8 Nm</p>  <p>xx1800003300</p>

Refitting the housing

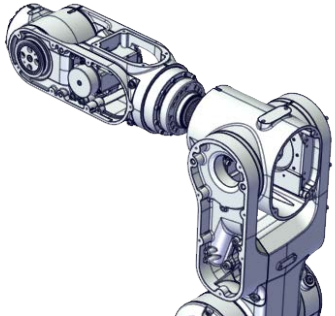
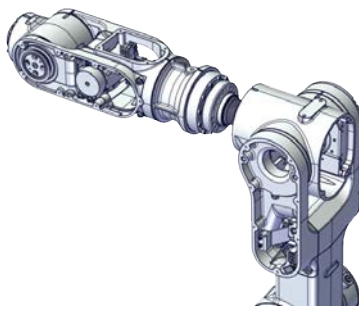
	Action	Note
1	For robots with protection type Clean Room: Clean the joints that have been opened and wipe the parts free from particles with spirit on a lint free.	
2	Valid for IRB 1100-4/0.475 Refit the the wrist to the housing.	 <p>xx1800003075</p>
3	Refit the extender unit and wrist to the housing.	 <p>xx1800003100</p>

Continues on next page

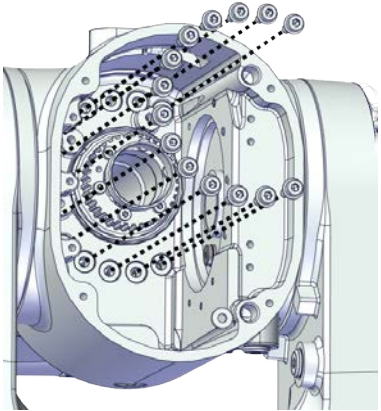
	Action	Note
4	<p>Refit the screws and washers.</p> <p> Note</p> <p>Some robots may be fitted with separate screws and washers. During replacement, always use the same screws (and washers) that are fitted on the robot at delivery. Contact ABB for more information.</p>	<p>Flange screws (14 pcs)</p> <p>For robots with protection class IP40</p> <p>Tightening torque: 1.9 Nm</p> <p>For robots with protection class IP67</p> <p>For robots with protection type Clean Room</p> <p>Tightening torque: 1.8 Nm</p>  <p>xx1900002191</p>

Refitting the axis-4 timing belt and pulley cover

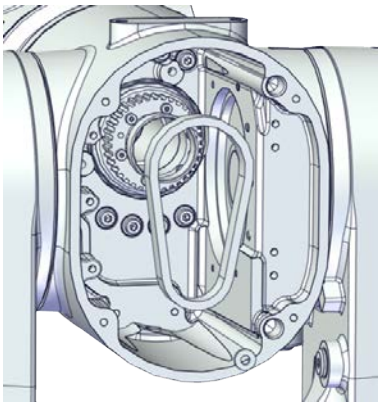
	Action	Note
1	<p>For robots with protection type Clean Room:</p> <p>Clean the joints that have been opened and wipe the parts free from particles with spirit on a lint free.</p>	
2	<p>Install the timing belt to the gearbox pulley and verify that the belt runs correctly in the groove of the pulley.</p>	 <p>xx1800003098</p>

Continues on next page

5 Repair

5.8.4 Replacing the axis-4 gearbox

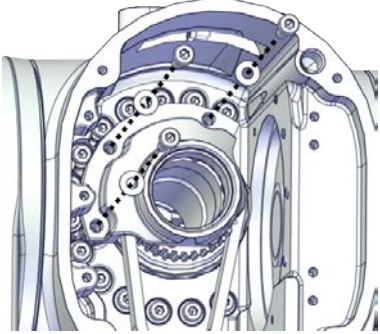

Continued

	Action	Note
3	Refit the pulley cover.	<p>Screw: M3x8 12.9 Lafre 2C2B/FC6.9 (3 pcs) Tightening torque: 1.2 Nm</p>  <p>xx1800003097</p>

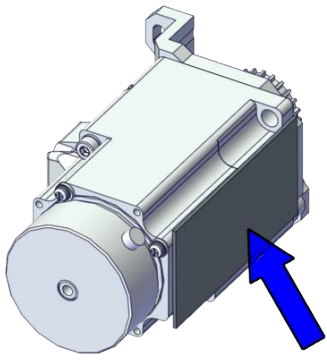
Refitting the axis-4 motor

	Action	Note
1	For robots with protection type Clean Room: Clean the joints that have been opened and wipe the parts free from particles with spirit on a lint free.	
2	Check that: <ul style="list-style-type: none">• all assembly surfaces are clean and without damages• the motor is clean and undamaged.	
3	Check the cooling pad. Replace if damaged.	<p>Cooling pad for axis-3 and -4 motors: 3HAC071021-001</p>  <p>xx1800003605</p>

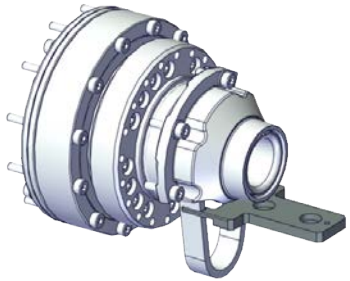
Continues on next page

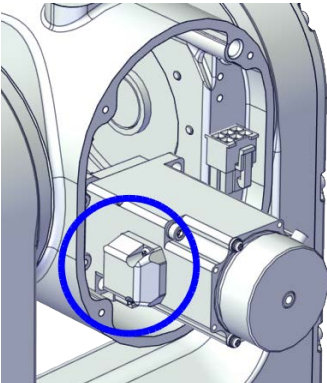
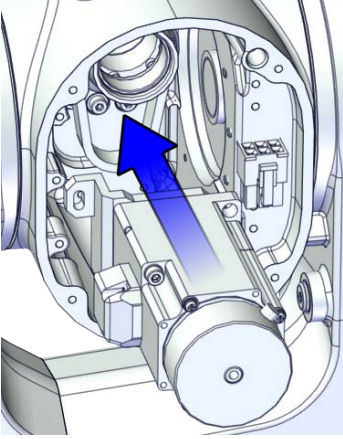
	Action	Note
4	Use the motor fitting tool to fix the timing belt.	<p>axis-4 motor fitting tool, included in the special toolkit 3HAC071022-001.</p>  <p>xx1900000044</p>
5	<p>Orient the motor correctly and fit it into the housing.</p> <p> Note</p> <p>Make sure the motor flange does not press on the timing belt.</p>	<p>Motor orientation: orient the motor according to the figure below, in regard to the encircled motor connector.</p>  <p>xx1800003287</p>
6	Install the timing belt to the motor pulley.	 <p>xx1800003617</p>

Continues on next page

5 Repair

5.8.4 Replacing the axis-4 gearbox

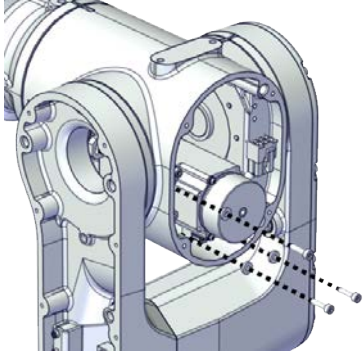

Continued

	Action	Note
7	Refit the screws and washers.  Note Do not tighten the screws yet.	Screw: M3x12 12.9 Lafre 2C2B/FC6.9 (3 pcs) Washer, 3HAC064765-001 (3 pcs)  xx1800003095
8	Remove the motor fitting tool.	

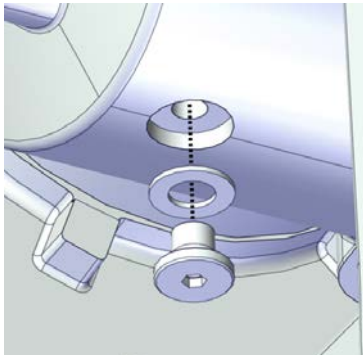
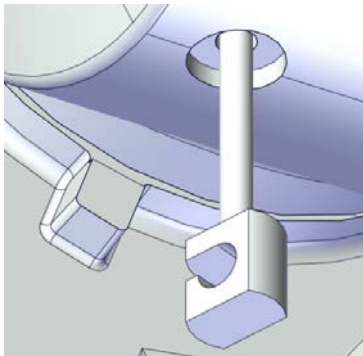
Adjusting the axis-4 timing belt tension

	Action	Note
1	For robots with protection type Clean Room: Clean the joints that have been opened and wipe the parts free from particles with spirit on a lint free.	
2	Remove the screw and washer below the housing.	 xx1900000036
3	Fit an M3x25 eye bolt to the screw hole.	 xx1900000037

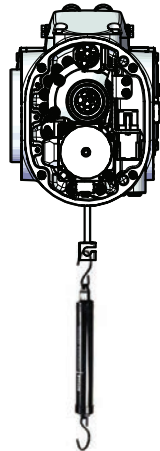
Continues on next page

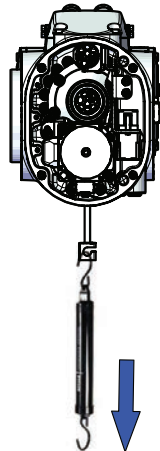
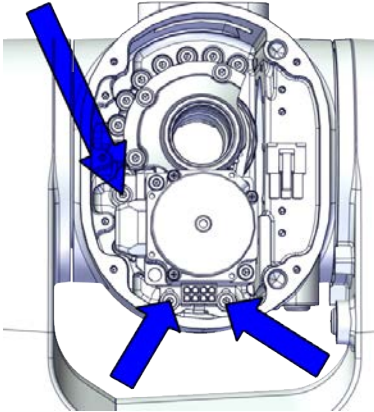
	Action	Note
4	Use a handheld dynamometer hooking to the eye bolt.	 <p>xx1900000038</p>
5	Pull the dynamometer to make the tension falling in the allowed force range.  Note Pay attention to the force application direction.	Used belt: 20.09-22.05 N New belt: 28.7-31.5 N  <p>xx1900000039</p>
6	Secure the motor with the screws.	Tightening torque: 1.4 Nm  <p>xx1800003094</p>

Continues on next page



5 Repair

5.8.4 Replacing the axis-4 gearbox

Continued

	Action	Note
7	Remove eye bolt and refit the screw and washer below the housing.	<p>Plug screw: 3HAC064146-001</p> <p>For robots with protection type Clean Room (option 3351-4)</p> <p>Plug screw, Clean Room: 3HAC070309-001</p> <p>For robots with protection class IP67 (option 3350-670)</p> <p>For robots with protection type Clean Room (option 3351-4)</p> <p>Rubber sealing washer on housing: 3HAC064147-001</p> <p>Tightening torque: 2 Nm</p>

Refitting the upper cable harness through the axis-4 gearbox

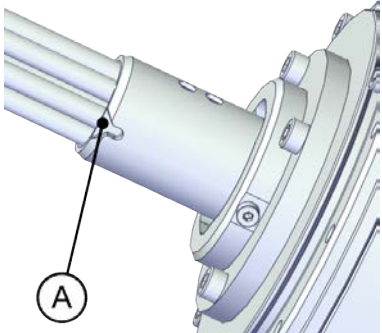
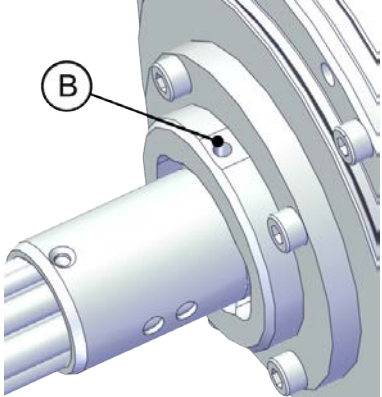
	Action	Note
1	For robots with protection type Clean Room: Clean the joints that have been opened and wipe the parts free from particles with spirit on a lint free.	
2	<p>Insert the cable package in the housing and through the axis-4 gearbox.</p> <p> Tip</p> <p>Wrap the connectors with the masking tape.</p> <p> CAUTION</p> <p>Make sure that no cables or hoses are twisted or strained. Reroute if necessary.</p>	<p>Cable protection tube orientation: use the notch (A) on the cable protection tube as a reference when inserting the cable package, which should be at the opposite direction to the locking screw hole (B) on the gearbox.</p>  <p>xx1800003017</p>  <p>xx1800003601</p>

Continues on next page

Securing the upper cable package to the axis-4 gearbox

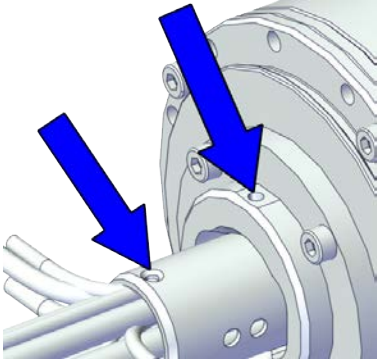
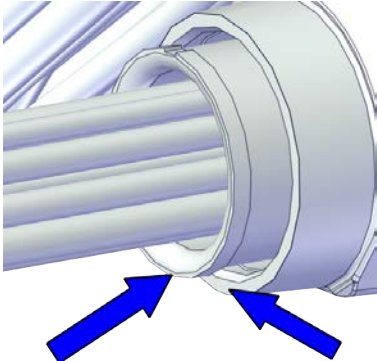
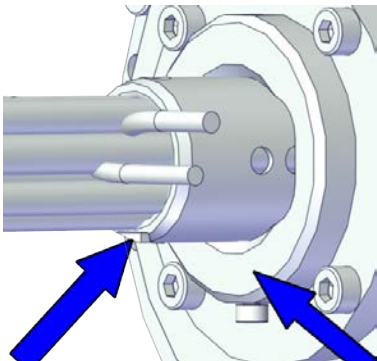

	Action	Note
1	For robots with protection type Clean Room: Clean the joints that have been opened and wipe the parts free from particles with spirit on a lint free.	
2	<p>Make sure that:</p> <ul style="list-style-type: none"> The hole on the cable protection tube is aligned with the locking screw hole on the gearbox. The cable protection tube surface is completely parallel with the pulley cover at one side and with the flange at the other side. 	<p>Holes to be aligned are shown in the following figure.</p>  <p>xx1800003018</p> <p>Surfaces to be paralleled are shown in the following figures.</p>  <p>xx1800003019</p>  <p>xx1800003020</p>

Continues on next page

5 Repair

5.8.4 Replacing the axis-4 gearbox

Continued

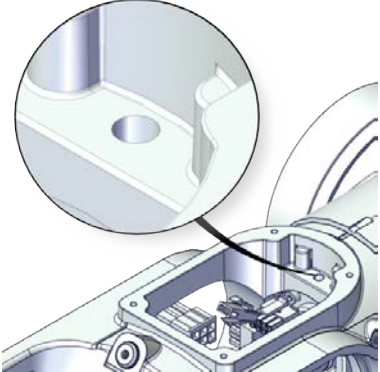
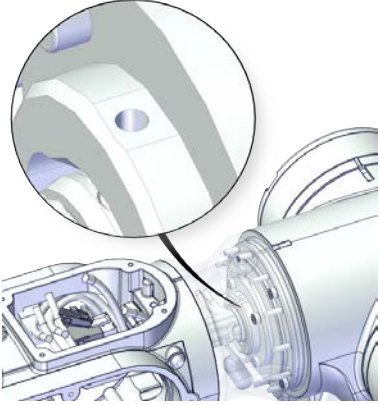
	Action	Note
3	<p>Apply a little Loctite 243 to the locking screw and refit the locking screw.</p> <p> Note</p> <p>Make sure the locking screw header is parallel with flange surface.</p> <p> Note</p> <p>If there is locking liquid residues on the screw or screw hole, please clean it before refitting. Remove residual locking liquid after refitting.</p>	<p>Screw: M3x8 (1 pcs) Tightening torque: 0.4 Nm Valid for IRB 1100-4/0.475</p>  <p>xx1800003031</p>  <p>xx1800003001</p>

Continues on next page

5.8.4 Replacing the axis-4 gearbox

Continued

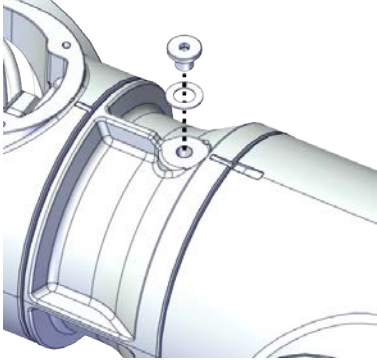
	Action	Note
4	Refit the plug screw and washer on the extender unit.	<p>Plug screw: 3HAC064146-001 For robots with protection type Clean Room (option 3351-4) Plug screw, Clean Room: 3HAC070309-001 For robots with protection class IP67 (option 3350-670) For robots with protection type Clean Room (option 3351-4) Rubber sealing washer on extender unit: 3HAC067995-001 Tightening torque: 2 Nm</p>  <p>xx1800003000</p>

Reconnecting the axis-4 motor connectors

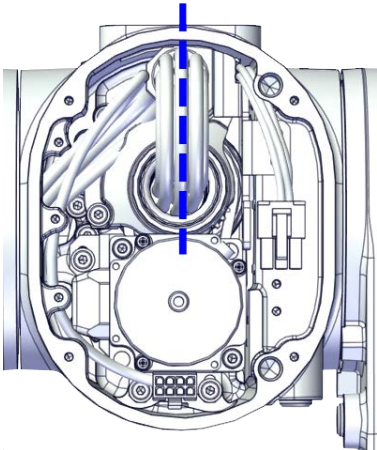
	Action	Note
1	For robots with protection type Clean Room: Clean the joints that have been opened and wipe the parts free from particles with spirit on a lint free.	
2	Check the cabling status. Make sure the cabling is in vertical state and is not twisted.	 <p>xx1800003618</p>

Continues on next page

5 Repair

5.8.4 Replacing the axis-4 gearbox

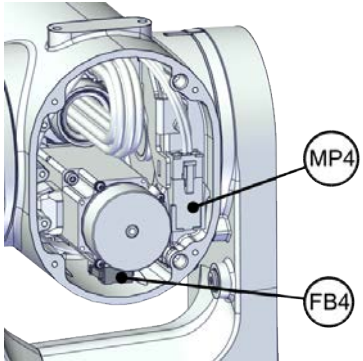

Continued

	Action	Note
3	<p>Reconnect the connectors.</p> <ul style="list-style-type: none"> • FB4 • MP4 <p> Tip</p> <p>See the number markings on the connectors for help to find the corresponding connector.</p>	 <p>xx1800003012</p>

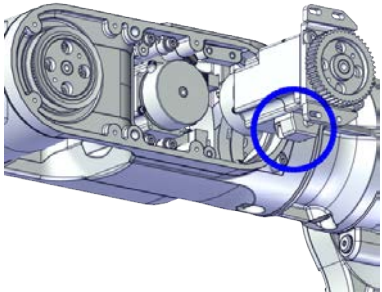
Refitting the axis-6 motor

	Action	Note
1	<p>For robots with protection type Clean Room: Clean the joints that have been opened and wipe the parts free from particles with spirit on a lint free.</p>	
2	<p>Check that:</p> <ul style="list-style-type: none"> • all assembly surfaces are clean and without damages • the motor is clean and undamaged. 	
3	<p>Orient the motor correctly and fit it into the lower arm.</p> <p> Tip</p> <p>Leave the connectors FB5 and FB6 accessible from the process hub and the connectors MP5 and MP6 accessible from wrist side.</p>	<p>Motor orientation: orient the motor according to the figure below, in regard to the encircled motor connector.</p>  <p>xx1800003023</p>

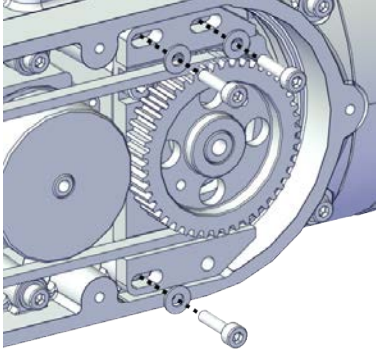
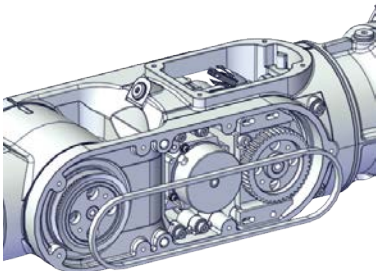
Continues on next page

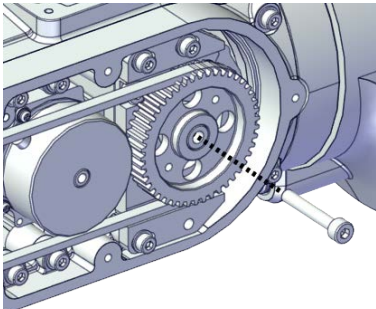
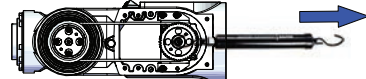
	Action	Note
4	<p>Refit the screws and washers.</p> <p> Note</p> <p>Do not tighten the screws yet.</p>	<p>Screw: M3x12 12.9 Lafre 2C2B/FC6.9 (3 pcs)</p>  <p>xx1800002996</p>
5	<p>Install the timing belt to the pulleys and verify that the belt runs correctly in the grooves of the pulleys.</p>	 <p>xx1800003024</p>
6	<p>Install an M4x25 or longer adjustment screw to the motor.</p> <p> Note</p> <p>Do not insert the entire screw to the hole.</p>	 <p>xx1900000007</p>
7	<p>Use a handheld dynamometer hooking to the screw and pull the dynamometer to reach the initial referenced force.</p>	<p>Initial referenced force for used belt: 8.96-9.8 N (for reference only) Initial referenced force for new belt: 12.8-14</p>  <p>xx1900000026</p>

Continues on next page

5 Repair

5.8.4 Replacing the axis-4 gearbox

Continued

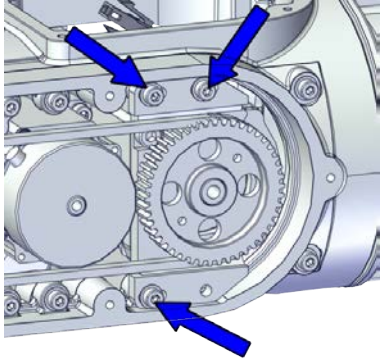
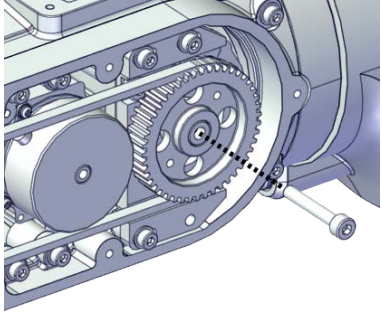

	Action	Note
8	Secure the motor with the screws.	<p>Tightening torque: 1.4 Nm</p>  <p>xx1800002995</p>
9	Use a sonic tension meter to measure the timing belt tension.	<p>Used belt: 81.3-86.9 Hz New belt: 90-114 Hz (for reference only)</p>
10	If the timing belt tension does not meet the requirement, loosen the motor screws and readjust.	
11	Remove the adjustment screw from the motor.	 <p>xx1900000007</p>

Reconnecting the axis-6 motor connectors

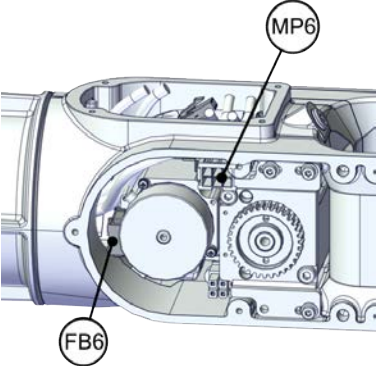

	Action	Note
1	For robots with protection type Clean Room: Clean the joints that have been opened and wipe the parts free from particles with spirit on a lint free.	

Continues on next page

5.8.4 Replacing the axis-4 gearbox
Continued

	Action	Note
2	<p>Reconnect the connectors.</p> <ul style="list-style-type: none"> • FB6 • MP6 <p> Tip</p> <p>See the number markings on the connectors for help to find the corresponding connector.</p>	 <p>xx1800002994</p>
3	<p>Route and secure the cabling with cable straps.</p> <p> CAUTION</p> <p>Correct cable routing is highly important. If the cables are routed and secured incorrectly the cables can be damaged.</p>	
4	<p>Insert the cabling and connectors into the wrist.</p>	

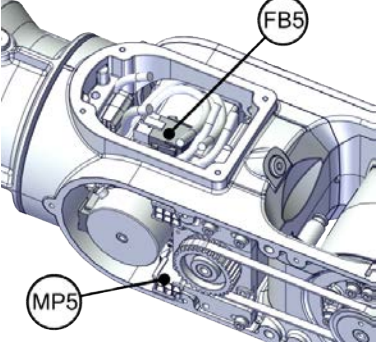
Reconnecting the axis-5 motor connectors

	Action	Note
1	<p>For robots with protection type Clean Room: Clean the joints that have been opened and wipe the parts free from particles with spirit on a lint free.</p>	
2	<p>Reconnect the connectors.</p> <ul style="list-style-type: none"> • FB5 • MP5 <p> Tip</p> <p>See the number markings on the connectors for help to find the corresponding connector.</p>	 <p>xx1800003025</p>
3	<p>Route and secure the cabling with cable straps.</p> <p> CAUTION</p> <p>Correct cable routing is highly important. If the cables are routed and secured incorrectly the cables can be damaged.</p>	
4	<p>Insert the cabling and connectors into the wrist.</p>	



Continues on next page

5 Repair

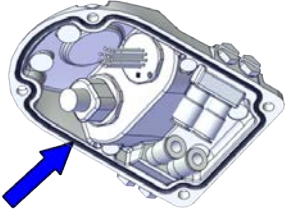

5.8.4 Replacing the axis-4 gearbox

Continued

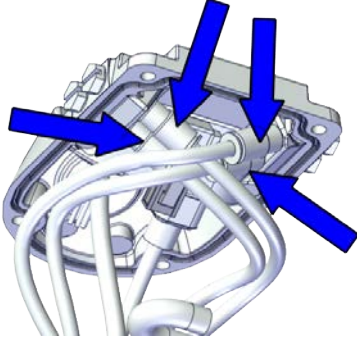
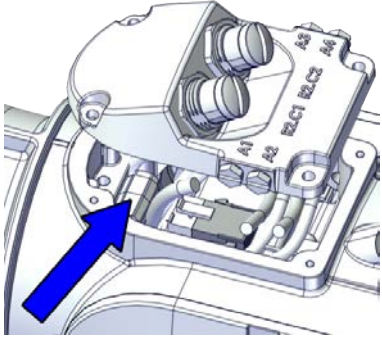
Refitting the process hub

	Action	Note
1	For robots with protection type Clean Room: Clean the joints that have been opened and wipe the parts free from particles with spirit on a lint free.	
2	For robots with protection class IP67 (option 3350-670) For robots with protection type Clean Room (option 3351-4) Check the gasket. Replace if damaged.	Gasket for process hub: 3HAC065352-001  xx1900002187
3	Reconnect the air hoses in a cross pattern.  Tip See the number markings on the air hoses for help to find the corresponding air hoses. The air hoses with the same number connect to the same Y-shaped connector.	 xx1800002945
4	For robots with CP/CS cabling Reconnect the connector. <ul style="list-style-type: none"> J5.C1 	 xx1800002947

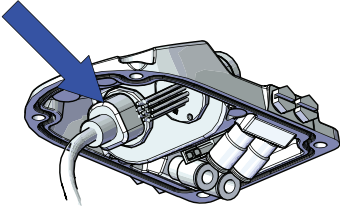
Continues on next page

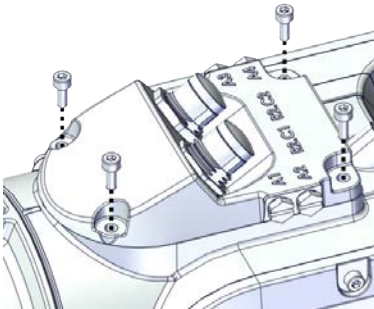
	Action	Note
5	<p>For robots with Ethernet cabling Reconnect the connector J5.C2 using the tool.</p>	<p>J5.C2 connector assembly tool, included in the special toolkit 3HAC071022-001</p>  <p>xx1800002948</p>
6	<p>Route and secure the cabling with cable straps.</p> <p> CAUTION</p> <p>Correct cable routing is highly important. If the cables are routed and secured incorrectly the cables can be damaged.</p>	
7	<p>Refit the cover.</p>	<p>Screw: M3x8 12.9 Lafre 2C2B/FC6.9 (4 pcs) Tightening torque: 1.2 Nm</p>  <p>xx1800002944</p>

Refitting the covers

	Action	Note
1	<p>For robots with protection type Clean Room: Clean the joints that have been opened and wipe the parts free from particles with spirit on a lint free.</p>	

Continues on next page



5 Repair

5.8.4 Replacing the axis-4 gearbox

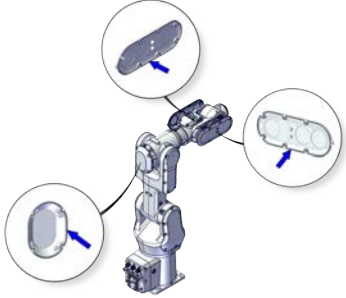
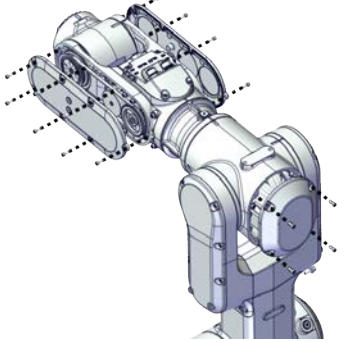
Continued

	Action	Note
2	<p>For robots with protection class IP67 (option 3350-670) For robots with protection type Clean Room (option 3351-4) Check the gaskets. Replace if damaged.</p>	 <p>xx2000002154</p>
3	Apply grease to the cable package, cover all moving area of the package.	
4	Apply grease to the covers that have contacting area with the cable package.	
5	<p>Refit the covers.</p> <ul style="list-style-type: none"> • Wrist covers • Housing cover 	<p>Screw: M3x8 12.9 Lafre 2C2B/FC6.9 Tightening torque: 1.2 Nm</p>  <p>xx2000002150</p>

Concluding procedure

	Action	Note
1	<p>For robots with protection type Clean Room: Clean and paint the joints that have been opened. See Cut the paint or surface on the robot before replacing parts on page 124</p> <p> Note</p> <p>After all repair work, wipe the Clean Room robot free from particles with spirit on a lint free cloth.</p>	
2	Recalibrate the robot.	Calibration is detailed in section Calibration on page 685 .
3	<p> DANGER</p> <p>Make sure all safety requirements are met when performing the first test run. See Test run after installation, maintenance, or repair on page 91.</p>	

6 Calibration

6.1 Introduction to calibration

6.1.1 Introduction and calibration terminology

Calibration information

This chapter includes general information about the recommended calibration methods and also the detailed procedures for updating the revolution counters, checking the calibration position etc.

Detailed instructions of how to perform Axis Calibration are given on the FlexPendant during the calibration procedure. To prepare calibration with Axis Calibration method, see [Calibrating with Axis Calibration method on page 695](#).

Calibration terminology

Term	Definition
Calibration method	A collective term for several methods that might be available for calibrating the ABB robot. Each method contains calibration routines.
Synchronization position	Known position of the complete robot where the angle of each axis can be checked against visual synchronization marks.
Calibration position	Known position of the complete robot that is used for calibration of the robot.
Standard calibration	A generic term for all calibration methods that aim to move the robot to calibration position.
Fine calibration	A calibration routine that generates a new zero position of the robot.
Reference calibration	<p>A calibration routine that in the first step generates a reference to current zero position of the robot. The same calibration routine can later on be used to recalibrate the robot back to the same position as when the reference was stored.</p> <p>This routine is more flexible compared to fine calibration and is used when tools and process equipment are installed.</p> <p>Requires that a reference is created before being used for recalibrating the robot.</p> <p>Requires that the robot is dressed with the same tools and process equipment during calibration as during creation of the reference values.</p>
Update revolution counter	A calibration routine to make a rough calibration of each manipulator axis.
Synchronization mark	Visual marks on the robot axes. When marks are aligned, the robot is in synchronization position.

6 Calibration

6.1.2 Calibration methods

6.1.2 Calibration methods

Overview

This section specifies the different types of calibration and the calibration methods that are supplied by ABB.

Types of calibration

Type of calibration	Description	Calibration method
Standard calibration	The calibrated robot is positioned at calibration position. Standard calibration data is found on the SMB (serial measurement board) or EIB in the robot.	Axis Calibration
Absolute accuracy calibration (optional)	Based on standard calibration, and besides positioning the robot at synchronization position, the Absolute accuracy calibration also compensates for: <ul style="list-style-type: none">Mechanical tolerances in the robot structureDeflection due to load Absolute accuracy calibration focuses on positioning accuracy in the Cartesian coordinate system for the robot. Absolute accuracy calibration data is found on the serial measurement board (SMB) or other robot memory. A robot calibrated with Absolute accuracy has the option information printed on its name plate (OmniCore). To regain 100% Absolute accuracy performance, the robot must be recalibrated for absolute accuracy after repair or maintenance that affects the mechanical structure.	CalibWare
Optimization	Optimization of TCP reorientation performance. The purpose is to improve reorientation accuracy for continuous processes like welding and gluing. Wrist optimization will update standard calibration data for axes 4, 5 and 6.	Wrist Optimization

Brief description of calibration methods

Axis Calibration method

Axis Calibration is a standard calibration method for calibration of IRB 1100. It is the recommended method in order to achieve proper performance.

The following routines are available for the Axis Calibration method:

- Fine calibration
- Update revolution counters
- Reference calibration

The calibration equipment for Axis Calibration is delivered as a toolkit.

An introduction to the calibration method is given in this manual, see [Calibrating with Axis Calibration method on page 695](#).

Continues on next page

The actual instructions of how to perform the calibration procedure and what to do at each step is given on the FlexPendant. You will be guided through the calibration procedure, step by step.

Wrist Optimization method

Wrist Optimization is a method for improving reorientation accuracy for continuous processes like welding and gluing and is a complement to the standard calibration method.

The actual instructions of how to perform the wrist optimization procedure is given on the FlexPendant.

CalibWare - Absolute Accuracy calibration

The CalibWare tool guides through the calibration process and calculates new compensation parameters. This is further detailed in the *Application manual - CalibWare Field*.

If a service operation is done to a robot with the option Absolute Accuracy, a new absolute accuracy calibration is required in order to establish full performance. For most cases after replacements that do not include taking apart the robot structure, standard calibration is sufficient.

The Absolute Accuracy option varies according to the robot mounting position. This is printed on the robot name plate for each robot. The robot must be in the correct mounting position when it is recalibrated for absolute accuracy.

References

Article numbers for the calibration tools are listed in the section [Special tools on page 734](#).

6 Calibration

6.1.3 When to calibrate

6.1.3 When to calibrate

When to calibrate

The system must be calibrated if any of the following situations occur.

The resolver values are changed

If resolver values are changed, the robot must be re-calibrated using the calibration methods supplied by ABB. Calibrate the robot carefully with standard calibration, according to information in this manual.

If the robot has *absolute accuracy* calibration, it is also recommended, but not always necessary to calibrate for new absolute accuracy.

The resolver values will change when parts affecting the calibration position are replaced on the robot, for example motors or parts of the transmission.

The revolution counter memory is lost

If the revolution counter memory is lost, the counters must be updated. See [Updating revolution counters on page 691](#). This will occur when:

- The battery is discharged
- A resolver error occurs
- The signal between a resolver and measurement board is interrupted
- A robot axis is moved with the control system disconnected

The revolution counters must also be updated after the robot and controller are connected at the first installation.

The robot is rebuilt

If the robot is rebuilt, for example, after a crash or when the reachability of a robot is changed, it needs to be re-calibrated for new resolver values.

If the robot has *absolute accuracy* calibration, it needs to be calibrated for new absolute accuracy.

Robot is not floor mounted

The original calibration data delivered with the robot is generated when the robot is floor mounted. If the robot is not floor mounted, then the robot accuracy could be affected. The robot needs to be calibrated after it is mounted.

6.2 Synchronization marks and axis movement directions

6.2.1 Synchronization marks and synchronization position for axes

Introduction

This section shows the position of the synchronization marks and the synchronization position for each axis.

Synchronization marks, IRB 1100

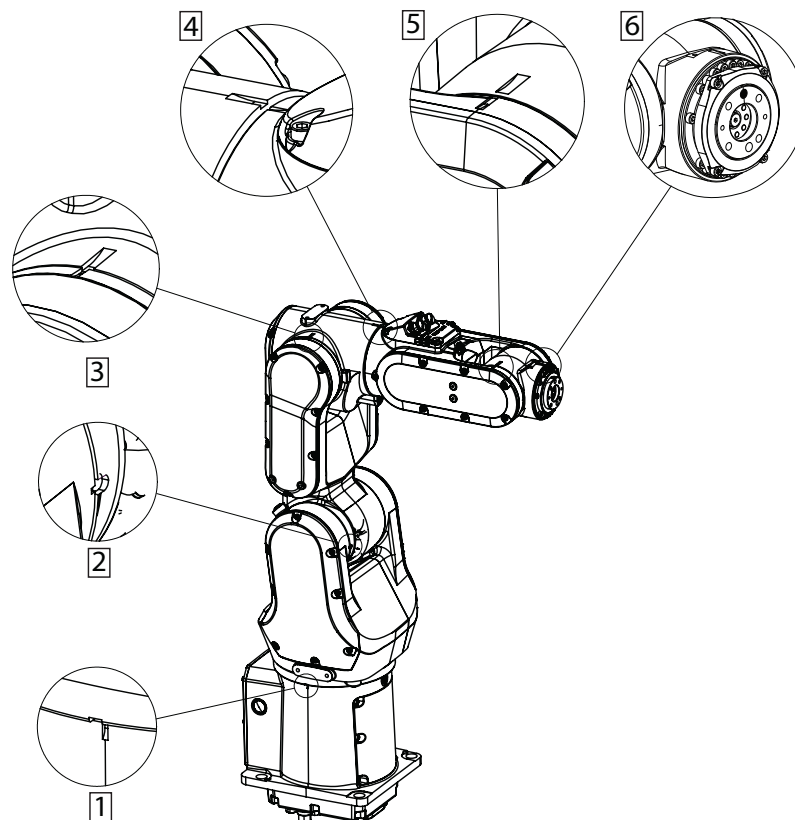

xx1800002455



CAUTION

To calibrate the axis 6, the notch on the wrist must be aligned with the marked pin hole on the tool flange. Before installing a tool on the tool flange, make sure a visible mark has been made to the tool at the corresponding position.

6 Calibration

6.2.2 Calibration movement directions for all axes

6.2.2 Calibration movement directions for all axes

Overview

When calibrating, the axis must consistently be run towards the calibration position in the same direction in order to avoid position errors caused by backlash in gears and so on. Positive directions are shown in the graphic below.

Calibration service routines will handle the calibration movements automatically and these might be different from the positive directions shown below.

Manual movement directions

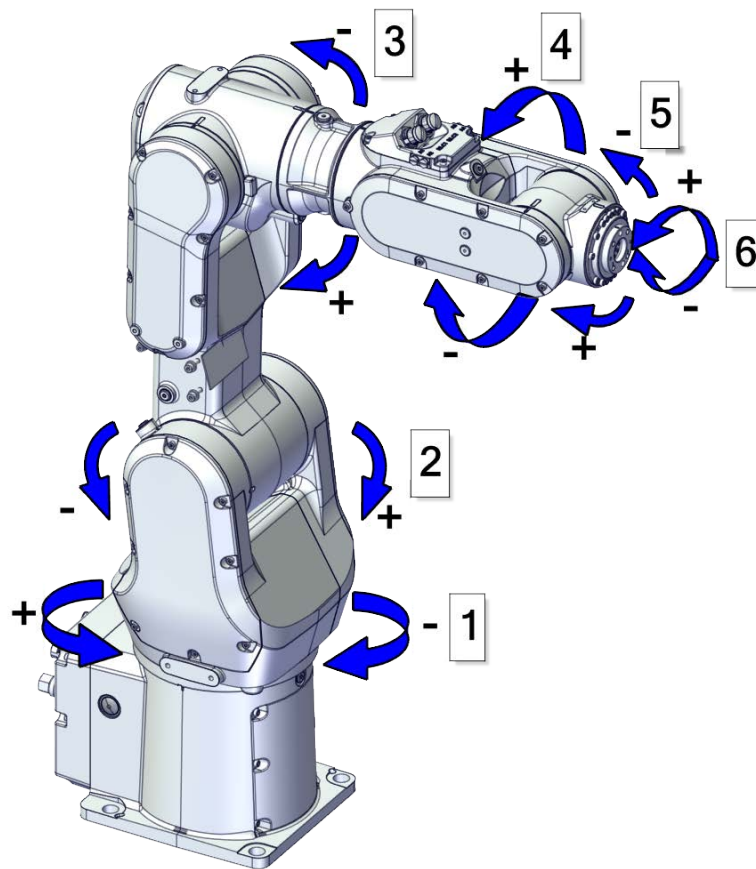

xx1800002456

6.3 Updating revolution counters

6.3.1 Updating revolution counters on OmniCore robots

Introduction

This section describes how to do a rough calibration of each manipulator axis by updating the revolution counter for each axis, using the FlexPendant.

Step 1 - Manually running the manipulator to the synchronization position

Use this procedure to manually run the manipulator to the synchronization position.

	Action	Note
1	Select axis-by-axis motion mode.	
2	Jog the manipulator to align the synchronization marks.	See Synchronization marks and synchronization position for axes on page 689 .
3	When all axes are positioned, update the revolution counter.	Step 2 - Updating the revolution counter with the FlexPendant on page 694 .

Correct calibration position of axis 4

When jogging the manipulator to synchronization position, it is extremely important to make sure that axis 4 is positioned correctly. Axis 4 can be calibrated at the wrong turn, resulting in an incorrect manipulator calibration.

Make sure axis 4 is positioned according to the cable harness status, not only according to the synchronization marks. Use the following procedure to check and correct the axis 4 position.

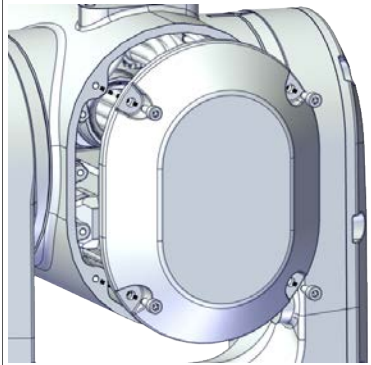
	Action	Note
1	Remove the housing cover.	 xx1800003011

Continues on next page

6 Calibration

6.3.1 Updating revolution counters on OmniCore robots

Continued

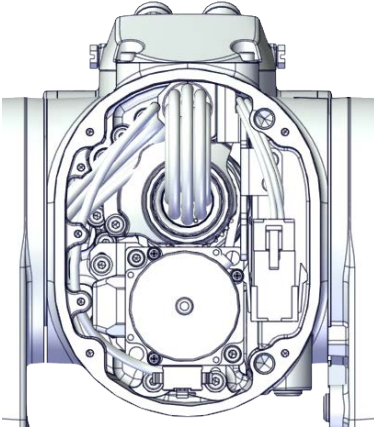
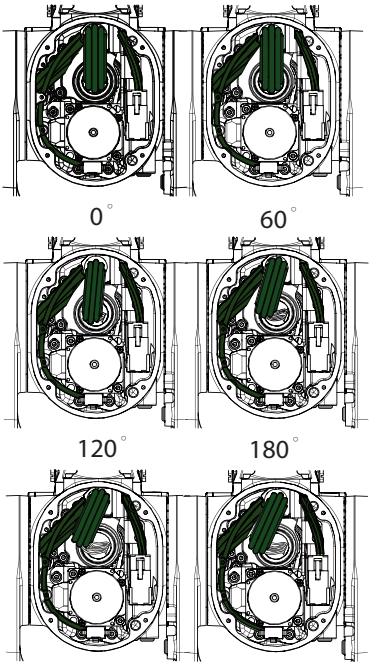
	Action	Note
2	<p>Inspect the cable harness status.</p> <p>The cable harness must be in vertical state as shown in the figure.</p> <ul style="list-style-type: none"> • If the cable harness twists towards left, proceed to step 3. • If the cable harness twists towards right, proceed to step 4. 	 <p>xx1800003317</p>
3	<p>Cable harness twisting towards left</p> <p>Jog the axis 4 anti-clockwise (with the operator facing the rear) until the cable harness is in vertical state.</p>	 <p>xx1800003318</p>

Continues on next page

6.3.1 Updating revolution counters on OmniCore robots

Continued

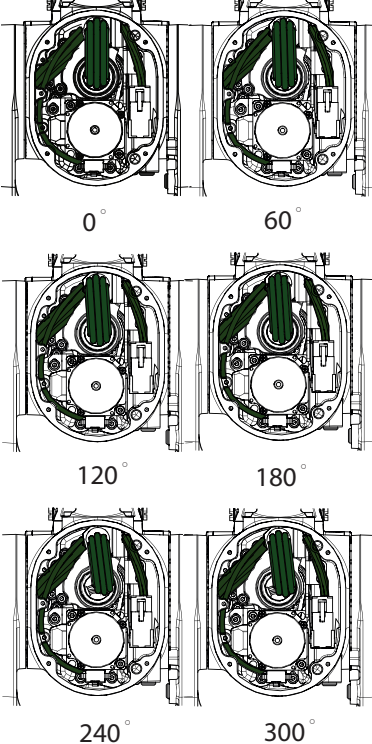
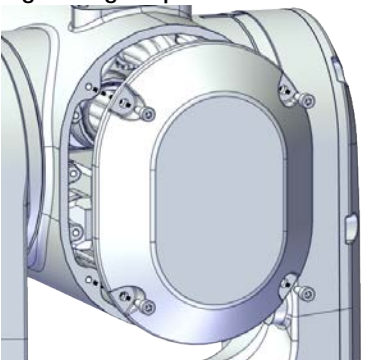
	Action	Note
4	<p>Cable harness twisting towards right Jog the axis 4 clockwise (with the operator facing the rear) until the cable harness begins turning left. Then, jog the axis 4 back until the cable harness is in vertical state.</p>	 <p>0° 60° 120° 180° 240° 300°</p> <p>xx1800003319</p>
5	<p>Refit the housing cover.</p>	<p>Screw: M3x8 (4 pcs) Tightening torque: 1.2 Nm</p>  <p>xx1800003011</p>

If the axis is rotated one or more turns from its calibration position before updating the revolution counter, the correct calibration position will be lost due to non-integer gear ratio.

At delivery the manipulator is in the correct position. Do NOT rotate axis 4 at power up before the revolution counters are updated.

Continues on next page



6 Calibration

6.3.1 Updating revolution counters on OmniCore robots

Continued

Step 2 - Updating the revolution counter with the FlexPendant

Use this procedure to update the revolution counter with the FlexPendant (OmniCore).

	Action
1	On the start screen, tap Calibrate . The calibration summary page for the mechanical unit is displayed.
2	In the Calibration Methods menu, select Revolution Counters .
3	In the Selection column select the axes for which revolution counters need to be updated.  Note A warning is displayed prompting you to check the cable harness status before proceeding with the revolution counter update for axis 4. See Correct calibration position of axis 4 on page 691 .
4	Tap Update . A dialog box is displayed warning that the updating operation cannot be undone.
5	Tap OK to update the revolution counter.
6	 CAUTION If a revolution counter is incorrectly updated, it will cause incorrect manipulator positioning, which in turn may cause damage or injury! Check the synchronization position very carefully after each update. See Checking the synchronization position on page 714 .

6.4 Calibrating with Axis Calibration method

6.4.1 Description of Axis Calibration

Instructions for Axis Calibration procedure given on the FlexPendant

The actual instructions of how to perform the calibration procedure and what to do at each step is given on the FlexPendant. You will be guided through the calibration procedure, step by step.

This manual contains a brief description of the method, additional information to the information given on the FlexPendant, article number for the tools and images of where to fit the calibration tools on the robot.

Overview of the Axis Calibration procedure

The Axis Calibration procedure applies to all axes, and is performed on one axis at the time. The robot axes are both manually and automatically moved into position, as instructed on the FlexPendant.

A fixed calibration pin/bushing is installed on each robot axis at delivery.

For axis 6 calibration there is one bushing on the wrist and one mounting hole on the tool flange.

The Axis Calibration procedure described roughly:

- 1 A removable calibration tool is inserted by the operator into a calibration bushing on the axis chosen for calibration, according to instructions on the FlexPendant.



WARNING

Calibrating the robot with Axis Calibration requires special calibration tools from ABB. Using other pins in the calibration bushings may cause severe damage to the robot and/or personnel.



WARNING

The calibration tool must be fully inserted into the calibration bushing, until the steel spring ring snaps into place.

- 2 During the calibration procedure, RobotWare moves the robot axis chosen for calibration so that the calibration tools get into contact. RobotWare records values of the axis position and repeats the coming-in-contact procedure several times to get an exact value of the axis position.



WARNING

Risk of pinching! The contact force for large robots can be up to 150 kg. Keep a safe distance to the robot.

Continues on next page

6 Calibration

6.4.1 Description of Axis Calibration

Continued

- 3 The axis position is stored in RobotWare with an active choice from the operator.

Routines in the calibration procedure

The following routines are available in the Axis Calibration procedure, given at the beginning of the procedure on the FlexPendant.

Fine calibration routine

Choose this routine to calibrate the robot when there are no tools, process cabling or equipment fitted to the robot.

Reference calibration routine



Note

Axes 5 and 6 of the IRB 1100 cannot be calibrated with reference calibration.

Choose this routine to create reference values and to calibrate the robot when the robot is dressed with tools, process cabling or other equipment.

Also choose this routine if the robot is wall mounted or suspended.



Note

When calibrating the robot with the reference calibration routine, the robot must be dressed with the same tools, process cabling and any other equipment as when the reference values were created.



Note

When using reference calibration with some tools, typically large or flexible tools, oscillations in the robot can cause issues leading to failure of the calibration.

If calibrating the robot with reference calibration there must be reference values created before repair is made to the robot, if values are not already available. Creating new values requires possibility to move the robot. The reference values contain positions of all axes, torque of axes and technical data about the tool installed. A benefit with reference calibration is that the current state of the robot is stored and not the state when the robot left the ABB factory. The reference value will be named according to tool name, date etc.

Follow the instructions given in the reference calibration routine on the FlexPendant to create reference values.

When reference calibration is performed, the robot is restored to the status given by the reference values.

Update revolution counters

Choose this routine to make a rough calibration of each manipulator axis by updating the revolution counter for each axis, using the FlexPendant.

Validation

In the mentioned routines, it is also possible to validate the calibration data.

Continues on next page

Position of robot axes

The robot axes should be positioned close to 0 degrees before commencing the calibration program. The axis chosen for calibration is then automatically run by the calibration program to its exact calibration position during the calibration procedure.

It is possible to position some of the other axes in positions different from 0 degrees. Information about which axes are allowed to be jogged is given on the FlexPendant. These axes are marked with **Unrestricted** in the FlexPendant window. Also the following table shows the dependencies between the axes.

Requirements for axis positioning during calibration

Required position of axis	Axis to calibrate					
	Axis 1	Axis 2	Axis 3	Axis 4	Axis 5	Axis 6
Axis 1	-	*	*	*	*	*
Axis 2	0	-	0	*	*	*
Axis 3	0	0	-	*	*	*
Axis 4	*	*	*	-	*	*
Axis 5	*	*	*	*	-	X
Axis 6	*	*	*	*	*	-

-	Axis to be calibrated
*	Unrestricted. Axis is allowed to be jogged to other position than 0 degrees.
0	Axis must be put in position 0 degrees.
X	Special requirement

System containing SafeMove

SafeMove will lose its synchronization to the controller if a new calibration is done. New calibration values have to be downloaded to SafeMove, and a new SafeMove calibration has to be done. Make sure that the user rights admit to change the safety settings and to synchronize SafeMove.

How to calibrate a suspended or wall mounted robot

The IRB 1100 is fine calibrated floor standing in factory, prior to shipping.

To calibrate a suspended or wall mounted robot, reference calibration could be used. Reference values for a suspended or a wall mounted robot must be created with the robot mounted at its working position, not standing on a floor.

To calibrate a suspended or wall mounted robot with the fine calibration routine, the robot must first be taken down and mounted standing on the floor.

6 Calibration

6.4.2 Calibration tools for Axis Calibration

6.4.2 Calibration tools for Axis Calibration

Calibration tool set

The calibration tools used for Axis Calibration are designed to meet requirements for calibration performance, durability and safety in case of accidental damage.

The calibration tool will eventually break from fatigue after longer period of use and then needs to be replaced. There is no risk for bad calibrations as long as the calibration tool is in one piece.



WARNING

Calibrating the robot with Axis Calibration requires special calibration tools from ABB. Using other pins in the calibration bushings may cause severe damage to the robot and/or personnel.

Equipment, etc.	Article number	Note
Calibration tool box, Axis Calibration	3HAC074119-001	Delivered as a set of calibration tools. Required if Axis Calibration is the valid calibration method for the robot. The tool box also includes a unique calibration pin for IRB 1100 to be fitted to the tool flange during calibration of axis 6.

Examining the calibration tool

Check prior to usage

Before using the calibration tool, make sure that the tube insert, the plastic protection and the steel spring ring are present.



WARNING

If any part is missing or damaged, the tool must be replaced immediately.

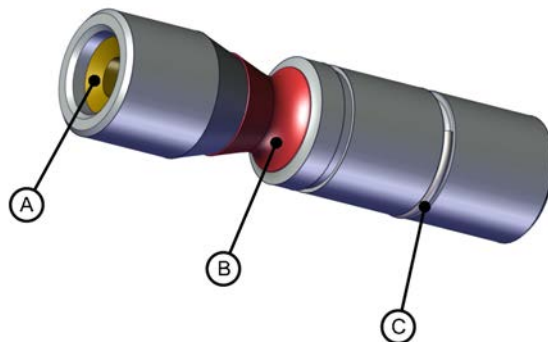

xx1500001914

A	Tube insert
B	Plastic protection
C	Steel spring ring

Continues on next page

Periodic check of the calibration tool

If including the calibration tool in a local periodic check system, the following measures should be checked.

- Outer diameter within $\varnothing 12g4$ mm, $\varnothing 8g4$ mm or $\varnothing 6g5$ mm (depending on calibration tool size).
- Straightness within 0.005 mm.

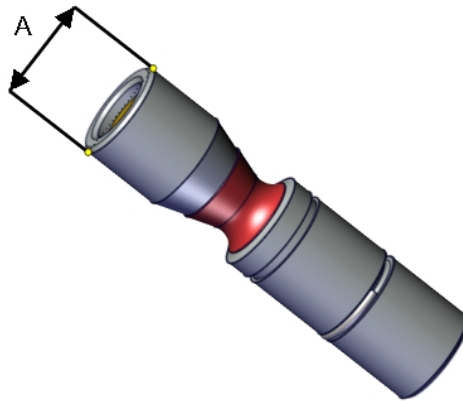

xx150000951

A	Outer diameter
---	----------------

Periodic check of the calibration tool for the tool flange (3HAC058238-001)

If including the tool flange calibration tool in a local periodic check system, the following measures should be checked.

- Outer diameter within $\varnothing 5g5$ mm.
- Straightness within 0.005 mm.

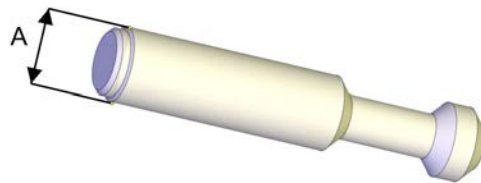

xx1600001142

A	Outer diameter
---	----------------

6 Calibration

6.4.3 Installation locations for the calibration tools

6.4.3 Installation locations for the calibration tools

Location of fixed calibration items

This section shows how the robot is equipped with items for installation of calibration tools for Axis Calibration (fixed calibration pins and/or bushings). Installed calibration tools are not shown.

A fixed calibration pin and a bushing for the movable calibration tool are located on each axis as follows.

If there is not enough space on an axis to install a fixed calibration pin, the axis is equipped with two bushings instead, for installation of two calibration tools when calibration is carried out. This is shown in the figure.

For axis 6 there is only one bushing, the second calibration tool is installed at the mounting flange of the turning disk.

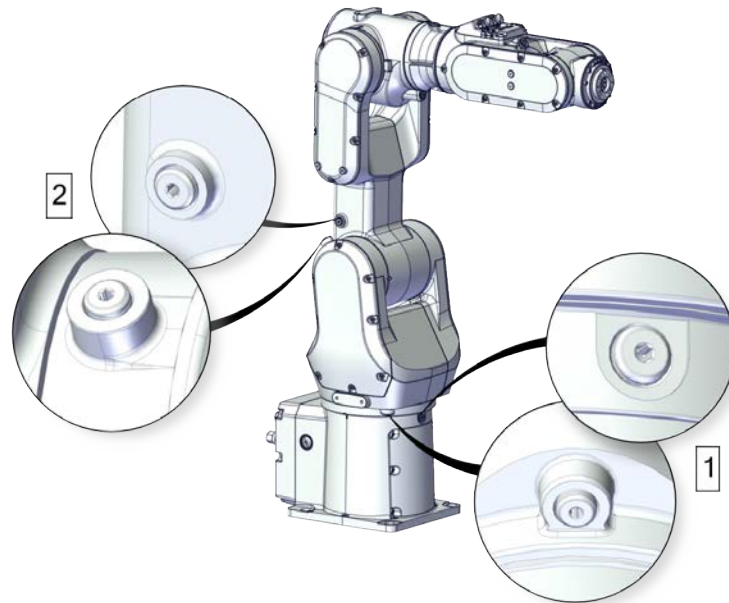

xx1800003320

Continues on next page

6.4.3 Installation locations for the calibration tools
Continued

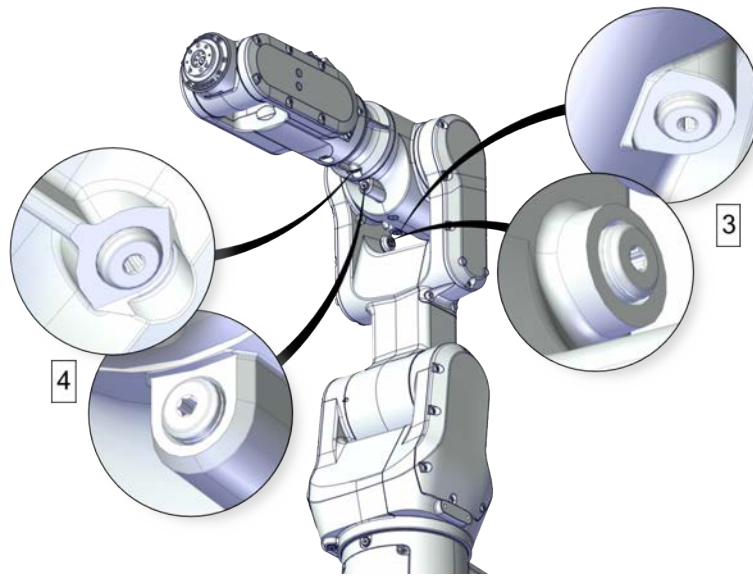

xx1800003514

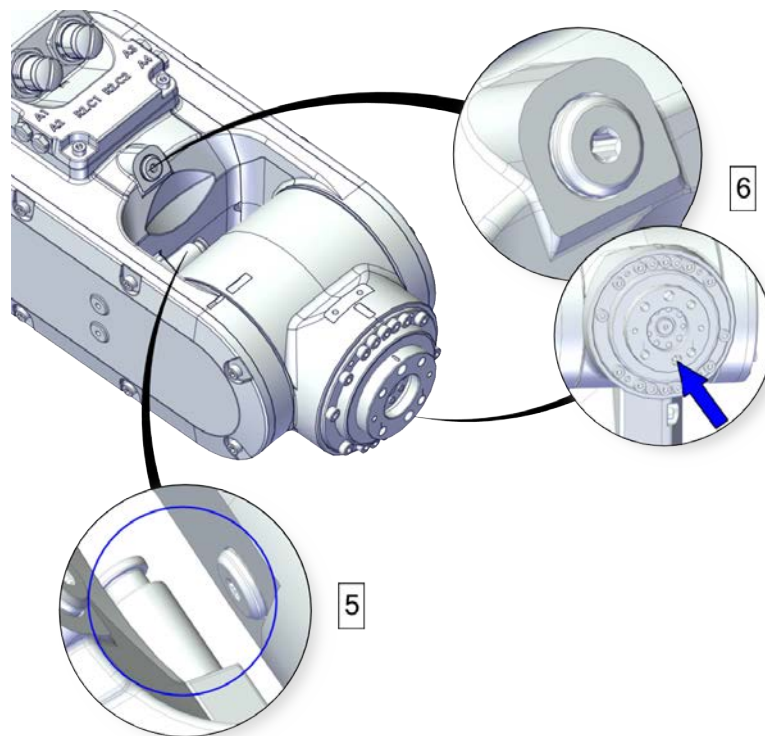

xx1800003515

Spare parts

When calibration is not being performed, a protective cover and an o-ring should always be installed on the fixed calibration pin as well as a protective plug, included a sealing, in the bushing. Replace damaged parts with new.

Spare part	Article number	Note
Protective plug for bushing	3HAC059556-001	Replace if damaged or missing.

Continues on next page

6 Calibration

6.4.3 Installation locations for the calibration tools

Continued

Spare part	Article number	Note
Protective plug for bushing, Clean Room	3HAC059557-001	Used with protection type Clean Room. Replace if damaged or missing.
Calibration pin cover, 6 mm	3HAC061926-001	Replace if damaged or missing.

6.4.4 Axis Calibration - Running the calibration procedure

Required tools

The calibration tools used for Axis Calibration are designed to meet requirements for calibration performance, durability and safety in case of accidental damage.



WARNING

Calibrating the robot with Axis Calibration requires special calibration tools from ABB. Using other pins in the calibration holes may cause severe damage to the robot and/or personnel.

Equipment, etc.	Article number	Note
Calibration tool box, Axis Calibration	3HAC074119-001	Delivered as a set of calibration tools. Required if Axis Calibration is the valid calibration method for the robot. The tool box also includes a unique calibration pin for IRB 1100 to be fitted to the tool flange during calibration of axis 6.

Required consumables

Consumable	Article number	Note
Clean cloth	-	

Spare parts

Spare part	Article number	Note
Protective plug for bushing	3HAC059556-001	Replace if damaged or missing.
Protective plug for bushing, Clean Room	3HAC059557-001	Used with protection type Clean Room. Replace if damaged or missing.
Calibration pin cover, 6 mm	3HAC061926-001	Replace if damaged or missing.

Overview of the calibration procedure on the FlexPendant

The actual instructions of how to perform the calibration procedure and what to do at each step is given on the FlexPendant. You will be guided through the calibration procedure, step by step.

Use the following list to learn about the calibration procedure before running the RobotWare program on the FlexPendant. It gives you a brief overview of the calibration procedure.

After the calibration method has been started on the FlexPendant, the following sequence will be run.

- 1 Choose calibration routine. The routines are described in [Routines in the calibration procedure on page 696](#).
- 2 Choose which axis/axes to calibrate.
- 3 The robot moves to synchronization position.
- 4 Validate the synchronization marks.

Continues on next page

6 Calibration

6.4.4 Axis Calibration - Running the calibration procedure



Continued

- 5 The robot moves to preparation position.
- 6 Remove the protective cover from the fixed pin and the protection plug from the bushing, if any, and install the calibration tool.
When calibrating axis 5, remove the protective cover from the fixed pin using a tweezer, and install the calibration tool.
- 7 The robot performs a measurement sequence by rotating the axis back and forth.
- 8 Remove the calibration tool and reinstall the protective cover on the fixed pin and the protection plug in the bushing, if any.
After the calibration of axis 5, refit the protective cover on the fixed pin for axis 5 using a tweezer.
- 9 The robot moves to verify that the calibration tool is removed.
- 10 Choose whether to save the calibration data or not.

Calibration of the robot is not finished until the calibration data is saved, as last step of the calibration procedure.

Preparation prior to calibration

The calibration procedure is described in the FlexPendant while conducting it.

	Action	Note
1	 DANGER While conducting the calibration, the robot needs to be connected to power. Make sure that the robot's working area is empty, as the robot can make unpredictable movements.	
2	Wipe the calibration tool clean.  Note The calibration method is exact. Dust, dirt or color flakes will affect the calibration value.	Use a clean cloth.
3	Check if the standard calibration data for axes 4, 5 or 6 are updated with wrist optimization. This is shown in the calibration overview/summary window on the FlexPendant.	If the data is optimized, the calibration routine Wrist Optimization must be re-run after standard calibration. See Calibrating with Wrist Optimization method on page 711 .

Starting the calibration procedure

Use this procedure to start the Axis Calibration routine on the FlexPendant.

	Action	Note
1	Tap the calibration icon and enter the calibration main page.	

Continues on next page

6.4.4 Axis Calibration - Running the calibration procedure

Continued

	Action	Note
2	<p>All mechanical units connected to the system are shown with their calibration status. Tap the mechanical unit in question.</p> <p> Note</p> <p>For RobotWare 7, the mechanical unit page is displayed only if there is more than one mechanical unit available.</p>	
3	<p>The calibration method used at ABB factory for each axis is shown, as well as calibration method used for the robot during last field calibration.</p>	<p>The FlexPendant will give all information needed to proceed with Axis Calibration.</p>
4	<p>Valid for RobotWare 7</p> <p>Tap Calibration Methods on the right pane and then tap Calibration. The software will automatically call for the procedure for the valid calibration method.</p>	
5	<p>Follow the instructions given on the FlexPendant.</p>	<p>A brief overview of the sequence that will be run on the FlexPendant is given in Overview of the calibration procedure on the FlexPendant on page 703.</p>

Fitting of calibration tools

The figures show the calibration tool in contact with the fixed pin on each axis.

The position of the complete robot shown for each axis is only an example.

In order for the axis to be able to be moved to calibration position, or in order for getting proper access to the calibration bushing, other axes might need to be jogged to positions different from 0 degrees. Information about which axes are

Continues on next page

6 Calibration

6.4.4 Axis Calibration - Running the calibration procedure

Continued

allowed to be jogged will be given on the FlexPendant. These axes are marked with **Unrestricted** in the FlexPendant window.

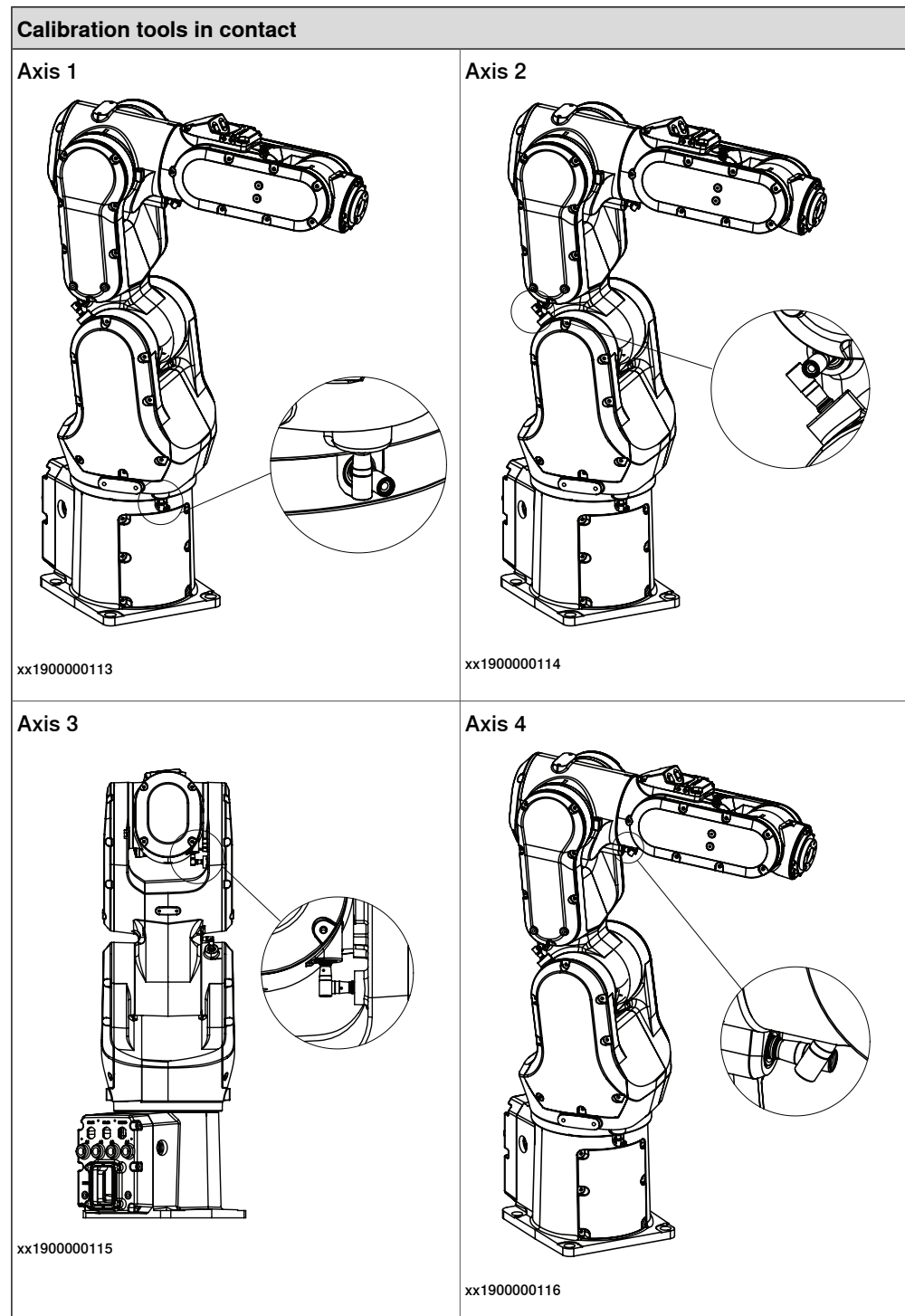

Continues on next page

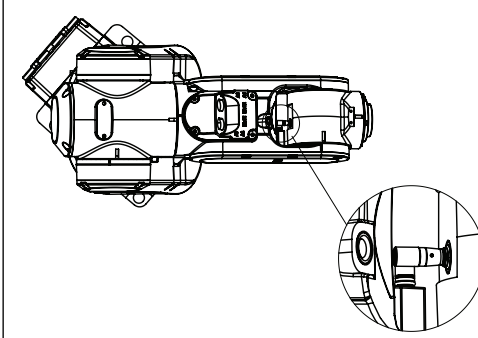
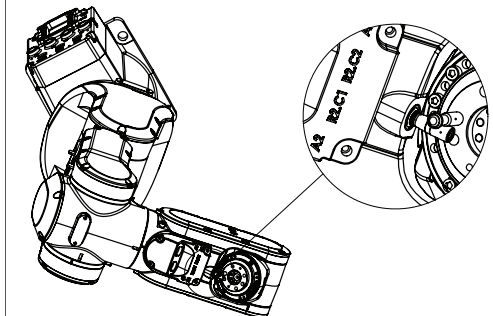
Calibration tools in contact	
<p>Axis 5</p>  <p>xx1900000117</p>	<p>Axis 6</p> <p>Make sure to orient the tool flange calibration tool correctly.</p>  <p>xx1900000118</p>

Restarting an interrupted calibration procedure

If the Axis Calibration procedure is interrupted before the calibration is finished, the RobotWare program needs to be started again. Use this procedure to take required action.

Situation	Action
The three-position enabling device on the FlexPendant has been released during robot movement.	Press and hold the three-position enabling device and press Play .
The RobotWare program is terminated with PP to Main .	Remove the calibration tool, if it is installed, and restart the calibration procedure from the beginning. See <i>Starting the calibration procedure</i> . If the calibration tool is in contact the robot axis needs to be jogged in order to release the calibration tool. Jogging the axis in wrong direction will cause the calibration tool to break. Directions of axis movement is shown in Calibration movement directions for all axes on page 690

Axis Calibration with SafeMove option

To be able to run Axis Calibration, SafeMove needs to be unsynchronized. The Axis Calibration routine recognizes if the robot is equipped with SafeMove and will force SafeMove to unsynchronize automatically.

However, SafeMove may generate other warning messages anytime during the Axis Calibration routine. When a warning message is displayed, tap **Acknowledge** to confirm the unsynchronized state and continue Axis Calibration procedure.



CAUTION

SafeMove must be synchronized after the calibration is completed.

Continues on next page

6 Calibration

6.4.4 Axis Calibration - Running the calibration procedure

Continued

After calibration

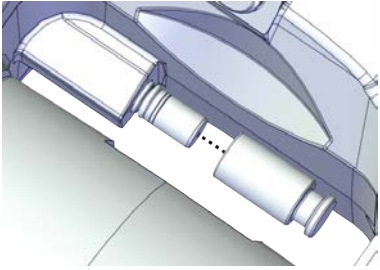
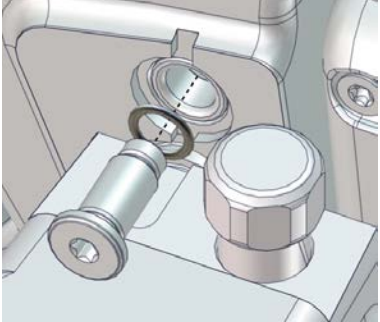
	Action	Note
1	<p>Reinstall the protective cover on the fixed calibration pin on each axis, directly after the axis has been calibrated.</p> <p>Replace the cover with new spare part, if missing or damaged.</p>	 <p>xx1900001421</p> <p>Calibration pin cover, 6 mm: 3HAC061926-001</p>
2	<p>Reinstall the protective plug and sealing in the bushing on each axis, directly after the axis has been calibrated. Ensure that the sealing is not damaged.</p> <p>Replace the plug and the sealing with new spare part, if missing or damaged.</p>	 <p>xx1500000952</p> <p>Protective plug for bushing: 3HAC059556-001.</p>
3	<p>If the standard calibration data for axes 4, 5 or 6 should be updated with wrist optimization, run the calibration routine Wrist Optimization.</p>	<p>See Calibrating with Wrist Optimization method on page 711.</p>

6.4.5 Reference calibration

Brief introduction to Reference Calibration

Reference calibration is a faster method compared to Fine calibration, as it refers to a previously made calibration.

- 1 Create a backup of the current robot system.
- 2 Check that the active calibration offset values corresponds to the values on the calibration label (located on the lower arm or the base).
- 3 Jog the manipulator so that all axes are in zero position (ex use `MoveAbsJ` instruction). Check that all axis scales are aligned with calibration marks.
- 4 If the scales differ from calibration marks it might depend on wrong turns of the revolution counters. Make a marker line on the corresponding axis to be able to validate the result of the calibration. If more than one motor revolutions are wrong, the calibration will fail.
- 5 Use a verification position. This is especially recommended if all axes were not aligned with the synchronization marks (step 3). Reuse an existing position that is suitable and accurate so it can be used to validate the repair. Use a position where a deviation in axis calibration gives a big deviation in positioning. Note! Check the position after each repair in one axis.
- 6 Use Reference calibration to save reference values for all axes that is to be replaced. Make sure that the values are saved in RobotStudio or FTP program. The files are located in "Active system folder name/HOME/RefCalibFiles".
- 7 Perform the repair.
- 8 Make sure that the tooling and process equipment are the same as when creating the reference. Use Reference calibration to update the system with new calibration offset value for the repaired axis.
- 9 Check the position against the verification position (step 5).
- 10 Proceed with the repair of the next axis, if necessary, and repeat (step 8-9) for every axis.
- 11 (For system containing SafeMove) Download new calibration values to SafeMove. Use Visual SafeMove in RobotStudio.
- 12 (For system containing SafeMove) Synchronize SafeMove to activate SafeMove.
- 13 Perform test run.
- 14 Update the calibration label with new resolver values (calibration values).

Manual tuning of calibration offset

Manual tuning of calibration offset is normally not needed, but can be useful in some situations. The requirement to do manual tuning is that there is a known accurate position, that worked accurately before the repair (step 5, see [Brief introduction to Reference Calibration on page 709](#)).

Example "Adjust axis 4":

- 1 Create a backup.

Continues on next page

6 Calibration

6.4.5 Reference calibration

Continued

- 2 Run the manipulator to the verification position. (The manipulator position is now deviating from the verification position.)
- 3 Read and note current axis 4 value in degrees (example: 96.3 degrees).
- 4 Manually jog, only axis 4, so that the manipulator is correctly positioned to the verification position.
- 5 Read and note current axis 4 value in degrees (example: 94.2 degrees).
- 6 Move the manipulator to its calibration position.
- 7 Calculate the angle difference (ie $96.3 - 94.2 = 2.1$ degrees).
- 8 Manually jog axis 4 the calculated angle difference (-2.1). NOTE! The direction +/- shall be the same direction as the direction used when axis 4 was manually jogged to coincide with the verification process. In the example -2.1 degrees.
- 9 Make a new manual fine calibration of axis 4 with axis in -2.1 degrees position.
- 10 Check again against the verification position.
- 11 Repeat the manual tuning if needed.
- 12 Create a new reference if the intention is to use the reference in the future.

6.5 Calibrating with Wrist Optimization method

When to run Wrist Optimization

Wrist Optimization routine is run to improve TCP reorientation performance.

Calibrating the robot with standard calibration method overwrites the optimized positions of axes 4, 5, 6. Re-run the **Wrist Optimization** routine after standard calibration to re-achieve the optimized positions of the wrist axes.

Overview of the calibration procedure on the FlexPendant

The actual instructions of how to perform the calibration procedure and what to do at each step is given on the FlexPendant. You will be guided through the calibration procedure, step by step.

Use the following list to learn about the calibration procedure before running the RobotWare program on the FlexPendant. It gives you a brief overview of the calibration procedure sequence.

After the calibration method has been called for on the FlexPendant, the following sequence will be run.

- 1 Choose calibration routine Wrist Optimization.
- 2 Modify targets for 4-point tool frame definition, in Wrist Optimization routine.



Tip

Select positions with large reorientations around the TCP. For best results, make sure that axis 4 and 5 have large movements.

- a Jog the robot to an appropriate position, A, for the first approach point.
Use small increments to accurately position the tool tip as close to the reference point as possible.
- b Tap **Modify Position** to define the point.
- c Repeat for each approach point to be defined, positions B, C, and D.
Jog away from the fixed world point to achieve the best result. Just changing the tool orientation will not give as good a result.

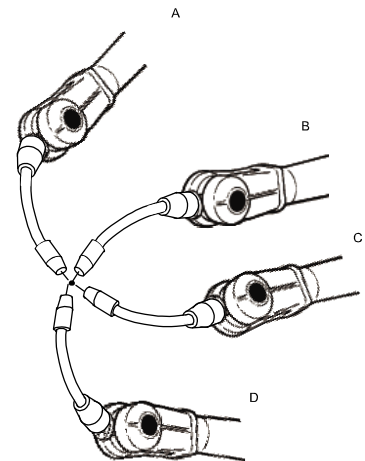

en040000906

- 3 Improved calibration data to the wrist axes is identified and presented.
- 4 Optimized positions for the wrist axes are presented.

Continues on next page

6 Calibration

6.5 Calibrating with Wrist Optimization method

Continued

- 5 The robot moves to the optimized positions for the wrist axes and automatically overwrites previous calibration data.



WARNING

Robot moves automatically when pressing **Calibrate**.

- 6 Wrist optimization is finished.
- 7 Redefine / verify TCP for all tools.

6.6 Verifying the calibration

Introduction

Always verify the results after calibrating *any* robot axis to verify that all calibration positions are correct.

Verifying the calibration

Use this procedure to verify the calibration result.

	Action	Note
1	Run the calibration home position program twice. Do not change the position of the robot axes after running the program!	See Checking the synchronization position on page 714 .
2	Adjust the <i>synchronization marks</i> when the calibration is done, if necessary.	This is detailed in section Synchronization marks and synchronization position for axes on page 689 .
3	Write down the values on a new label and stick it on top of the calibration label. The label is located on one side of the base.	

6 Calibration

6.7 Checking the synchronization position

6.7 Checking the synchronization position

Introduction

Check the synchronization position of the robot before beginning any programming of the robot system. This may be done:

- Using a `MoveAbsJ` instruction with argument zero on all axes.
- Using the **Jog** window on the FlexPendant.

Using a `MoveAbsJ` instruction

Use this procedure to create a program that runs all the robot axes to their synchronization position.

	Action	Note
1	Tap Code .	
2	Create a new program.	
3	Use MoveAbsJ in the Add Instruction menu.	
4	Create the following program: <pre>MoveAbsJ [[0,0,0,0,0,0], [9E9,9E9,9E9,9E9,9E9,9E9]] \NoEOffs, v1000, fine, tool0</pre>	
5	Run the program in manual mode.	
6	Check that the synchronization marks for the axes align correctly. If they do not, update the revolution counters.	See Synchronization marks and synchronization position for axes on page 689 and Updating revolution counters on page 691 .

Using the jogging window

Use this procedure to jog the robot to the synchronization position of all axes.

	Action	Note
1	Tap Jog .	
2	From the Mechanical unit list select a mechanical unit.	
3	From the Motion mode section, select an axis-set that need to be jogged. For example, to jog axis 2, select the axis set Axis 1-3 .	
4	Follow the screen instruction on joystick movements to understand the direction of the axis that you want to move and move the joystick.	
5	Manually run the robots axes to a position where the axis position value read on the FlexPendant, is equal to zero.	
6	Check that the synchronization marks for the axes align correctly. If they do not, update the revolution counters.	See Synchronization marks and synchronization position for axes on page 689 and Updating revolution counters on page 691 .

7 Troubleshooting

7.1 Introduction to troubleshooting

Introduction

The product manual and the circuit diagram contains information that can be good when troubleshooting.

For OmniCore, all event logs from the software can be seen on the FlexPendant, or in *Technical reference manual - Event logs for RobotWare 7*.

Make sure to read through the section [Safety on page 17](#) before starting.

Troubleshooting strategies

- 1 Isolate the fault to pinpoint the cause of the problem from consequential problems.
- 2 Divide the fault chain in two.
- 3 Check communication parameters and cables.
- 4 Check that the software version is compatible with the hardware.

Work systematically

- 1 Take a look around to make sure that all screws, connectors, and cables are secured, and that the robot and other parts are clean, not damaged, and correctly fitted.
- 2 Replace one thing at a time.
- 3 Do not replace units randomly.
- 4 Make sure that there are no loose screws, turnings, or other unexpected parts remaining after work has been performed.
- 5 When the work is completed, verify that the safety functions are working as intended.

Keep a track of history

- Make a historical fault log to keep track of problems over time.
- Consult those working with the robot when the problem occurred.

Basic scenarios

What to look for during troubleshooting depends on when the fault occurred. Was the robot recently installed or was it recently repaired? The following table gives hints on what to look for in specific situations.

The robot has recently been installed	Check: <ul style="list-style-type: none"> • the configuration files • connectors • options and their configuration • changes in the robot working space/movements.
---------------------------------------	--------------------------------------------------------------------------------------------------------------------------------------------------------------------------------------------------------------

Continues on next page

7 Troubleshooting

7.1 Introduction to troubleshooting

Continued

The robot has recently been repaired	Check: <ul style="list-style-type: none">• all connections to the replaced part• power supplies• that the correct part has been fitted• the last repair documents.
The robot recently had a software upgrade	Check: <ul style="list-style-type: none">• software versions• compatibilities between hardware and software• options and their configuration
The robot has recently been moved from one site to another (an already working robot)	Check: <ul style="list-style-type: none">• connections• software versions

7.2 Oil and grease stains on motors and gearboxes

Description

The area surrounding the motor, gearbox or seal lip shows signs of oil leaks. This can be at the base, closest to the mating surface, at the furthest end of the motor at the resolver, or around the joints of the covers (closest to the edge) on the robot surface.

Consequences

Besides the dirty appearance, in most cases there are no serious consequences if the leaked amount of oil is very small.

Possible causes

The symptom can be caused by:

- Leakage of rust preventives or mounting grease. This should be wiped off.
- Leaking sealing between gearbox and motor.
- Gearbox overfilled with oil.
- Gearbox oil too hot.

Recommended actions

The following actions are recommended:

	Action	Information
1	 CAUTION Allow hot parts to cool down.	
2	Wipe off the oil or grease, see Cleaning the IRB 1100 on page 98 . Monitor the robot over time to see if new oil or grease occurs.	If the oil spill is small, this step is sufficient.
3	Check the gearbox oil level.	
4	Too hot gearbox oil may be caused by: <ul style="list-style-type: none"> • Incorrect oil quality or level. • The robot work cycle runs a specific axis too hard. Investigate whether it is possible to program small "cooling periods" into the application. • Overpressure created inside gearbox. 	Robots performing certain, extremely heavy duty work cycles may be fitted with vented oil plugs. These are not fitted to normal duty robots, but can be purchased from your local ABB representative.
5	Inspect all sealings and gaskets between motor and gearbox. Replace broken parts.	

7 Troubleshooting

7.3 Mechanical noise or dissonance

7.3 Mechanical noise or dissonance

Description

Mechanical noise or dissonance that has not been observed before can indicate problems in bearings, motors, gearboxes, or similar. Be observant of changes over time.

A faulty bearing often emits scraping, grinding, or clicking noises shortly before failing.

A humming resonance sound can occur without being an error. Mechanical resonance sound is a physical phenomenon in mechanical structures. It has no impact on product performance or lifetime. Adjusting the robot movement speed out of the range that causes the resonance will eliminate the sound.

Consequences

Failing bearings cause the path accuracy to become inconsistent, and in severe cases, the joint can seize completely.

Possible causes

The symptom can be caused by:

- Worn bearings.
- Contaminations have entered the bearing grooves.
- Loss of lubrication in bearings.
- Loose heat sinks, fans, or metal parts.

If the noise is emitted from a gearbox, the following can also apply:

- Overheating.

Recommended actions

The following actions are recommended:

	Action	Information
1	 CAUTION Allow hot parts to cool down.	
2	Verify that the service is done according to the maintenance schedule.	
3	If a bearing is emitting the noise, determine which one and make sure that it has sufficient lubrication.	
4	If possible, disassemble the joint and measure the clearance.	
5	Bearings inside motors are not to be replaced individually, but the complete motor is replaced.	
6	Make sure the bearings are fitted correctly.	
7	Tighten the screws if a heat sink, fan, or metal sheet is loose.	

7.4 Manipulator collapses on power down

Description

The manipulator is able to work correctly while Motors ON is active, but when Motors OFF is active, one or more axes drops or collapses under its own weight. The holding brakes (normally one in each motor), is not able to hold the weight of the manipulator arm.

Consequences

For a heavy robot, the collapse can cause severe injury to personnel working in the area or severe damage to the robot and/or surrounding equipment.
For a small robot, the collapse can cause injury to personnel working close to the robot or damage to the robot and/or surrounding equipment.

Possible causes

The symptom can be caused by:

- Faulty brake.
- Faulty power supply to the brake.

Recommended actions

The following actions are recommended:

	Action	Information
1	Determine which motor(s) causes the robot to collapse.	
2	Check the brake power supply to the collapsing motor during the Motors OFF state.	See the circuit diagram.
3	Remove the resolver or resolver cover of the motor to see if there are any signs of oil leaks.	If found faulty, the motor must be replaced as a complete unit.
4	Remove the motor from the gearbox to inspect it from the drive side.	If found faulty, the motor must be replaced as a complete unit.

7 Troubleshooting

7.5 Motor temperature too high

7.5 Motor temperature too high

Description

The robot stops and the motor temperature for joint arg is too high.

Consequences

It is not possible to continue until the motor has cooled down. The system goes to Motors Off.

Possible causes

The symptom can be caused by:

- The values for payload and arm load are not consistent with the actual ones.
- The value for ambient temperature setting in the controller is not consistent with the actual operating temperature environment.
- The user program may contain too much high acceleration and deceleration of the joint.
- Gravity torque or external forces for the joint can also be too high.

Recommended actions

The following actions are recommended:

	Action	Information
1	 CAUTION Allow hot parts to cool down.	
2	Verify that the values for payload and arm load are set correctly.	
3	Verify that the value for ambient temperature setting in the controller is consistent with the actual operating temperature environment.	
4	Rewrite the user program to reduce the motor utilization.	The ways could be but not limited to optimizing robot movement cycle, adjusting acc, dec as well as external force, adding wait time, and introducing alternative path/RAPID, etc.

8 Decommissioning

8.1 Introduction to decommissioning

Introduction

This section contains information to consider when taking a product, robot or controller, out of operation.

It deals with how to handle potentially dangerous components and potentially hazardous materials.



Note

The decommissioning process shall be preceded by a risk assessment.

Disposal of materials used in the robot

All used grease/oils and dead batteries **must** be disposed of in accordance with the current legislation of the country in which the robot and the control unit are installed.

If the robot or the control unit is partially or completely disposed of, the various parts **must** be grouped together according to their nature (which is all iron together and all plastic together), and disposed of accordingly. These parts **must** also be disposed of in accordance with the current legislation of the country in which the robot and control unit are installed.

See also [Environmental information on page 722](#).

Transportation

Prepare the robot or parts before transport, this to avoid hazards.

8 Decommissioning

8.2 Environmental information

8.2 Environmental information

Introduction

ABB robots contain components in different materials. During decommissioning, all materials should be dismantled, recycled, or reused responsibly, according to the relevant laws and industrial standards. Robots or parts that can be reused or upcycled helps to reduce the usage of natural resources.

Symbol

The following symbol indicates that the product must not be disposed of as common garbage. Handle each product according to local regulations for the respective content (see table below).



xx180000058

Materials used in the product

The table specifies some of the materials in the product and their respective use throughout the product.

Dispose components properly according to local regulations to prevent health or environmental hazards.

Material	Example application
Aluminium	Base, base adapter, swing, swing support, lower arm, lower arm support, swing, covers, motors, gearboxes, SMB unit, etc
Batteries, Lithium	Serial measurement board
Copper	Cables, motors
Lead	Serial measurement board
Neodymium	Motors
Oil, grease	Gearboxes, process hub, etc
Plastic/rubber	Cables, SMB unit, gearboxes, timing belt, cooling pads, connector kits, etc
Steel	Base, swing, lower arm, extender unit, wrist, motors, gearboxes, SMB unit, etc

Continues on next page

China RoHS symbol

The following symbol shows the information to hazardous substances and the environmental protection use period of IRB 1100 according to "Management Methods for the Restriction of the Use of Hazardous Substances in Electrical and Electronic Products (SJ/T 11364-2014)".



xx190000803

Green symbol with "e" in it: The product does not contain any hazardous substances exceeding concentration limits and is a green environmentally friendly product which can be recycled.

Oil and grease

Where possible, arrange for oil and grease to be recycled. Dispose of via an authorized person/contractor in accordance with local regulations. Do not dispose of oil and grease near lakes, ponds, ditches, down drains, or onto soil. Incineration must be carried out under controlled conditions in accordance with local regulations.

Also note that:

- Spills can form a film on water surfaces causing damage to organisms. Oxygen transfer could also be impaired.
- Spillage can penetrate the soil causing ground water contamination.

8 Decommissioning

8.3 Scrapping of robot

8.3 Scrapping of robot



Note

The decommissioning process shall be preceded by a risk assessment.

Important when scrapping the robot



DANGER

The risk assessment should consider hazards arising in the decommissioning, such as, but not limited to:

- Always remove all batteries. If a battery is exposed to heat, for example from a blow torch, it will explode.
- Always remove all oil/grease in gearboxes. If exposed to heat, for example from a blow torch, the oil/grease will catch fire.
- When motors are removed from the robot, the robot will collapse if it is not properly supported before the motor is removed.
- A used robot does not have the same performance as on delivery. Springs, brakes, bearings, and other parts might be worn or broken.

9 Reference information

9.1 Introduction

General

This chapter includes general information, complementing the more specific information in the different procedures in the manual.

9 Reference information

9.2 Applicable standards

9.2 Applicable standards

General

The product is compliant with ISO 10218-1:2011, *Robots for industrial environments - Safety requirements - Part 1 Robots*, and applicable parts in the normative references, as referred to from ISO 10218-1:2011. In case of deviation from ISO 10218-1:2011, these are listed in the declaration of incorporation. The declaration of incorporation is part of the delivery.

Robot standards

Standard	Description
ISO 9283	Manipulating industrial robots – Performance criteria and related test methods
ISO 9787	Robots and robotic devices – Coordinate systems and motion nomenclatures
ISO 9946	Manipulating industrial robots – Presentation of characteristics

Other standards used in design

Standard	Description
IEC 60204-1	Safety of machinery - Electrical equipment of machines - Part 1: General requirements, normative reference from ISO 10218-1
IEC 61000-6-2	Electromagnetic compatibility (EMC) – Part 6-2: Generic standards – Immunity standard for industrial environments
IEC 61000-6-4	Electromagnetic compatibility (EMC) – Part 6-4: Generic standards – Emission standard for industrial environments
ISO 13849-1:2006	Safety of machinery - Safety related parts of control systems - Part 1: General principles for design, normative reference from ISO 10218-1
IEC 61340-5-1	Protection of electronic devices from electrostatic phenomena - General requirements

Region specific standards and regulations

Standard	Description
ANSI/RIA R15.06	Safety requirements for industrial robots and robot systems
ANSI/UL 1740	Safety standard for robots and robotic equipment
CAN/CSA Z 434-03	Industrial robots and robot Systems - General safety requirements
ANSI/ESD S20.20	Protection of Electrical and Electronic Parts, Assemblies and Equipment (Excluding Electrically Initiated Explosive Devices)
EN ISO 10218-1	Robots and robotic devices — Safety requirements for industrial robots — Part 1: Robots

Continues on next page

Deviations

Deviation for IRB 1100

The IRB 1100 does not provide means of installing adjustable mechanical stops on axis 1. Optional features provided by SafeMove, safety-rated soft axis and space limiting can be used as risk reduction measures in specific applications.

For details about SafeMove, see *Application manual - Functional safety and SafeMove*.

9 Reference information

9.3 Unit conversion

9.3 Unit conversion

Converter table

Use the following table to convert units used in this manual.

Quantity	Units		
Length	1 m	3.28 ft.	39.37 in
Weight	1 kg	2.21 lb.	
Weight	1 g	0.035 ounces	
Pressure	1 bar	100 kPa	14.5 psi
Force	1 N	0.225 lbf	
Moment	1 Nm	0.738 lbf-ft	
Volume	1 L	0.264 US gal	

9.4 Screw joints

General

This section describes how to tighten the various types of screw joints on ABB robots.

The instructions and torque values are valid for screw joints comprised of metallic materials and do *not* apply to soft or brittle materials.

UNBRAKO screws

UNBRAKO is a special type of screw recommended by ABB for certain screw joints. It features special surface treatment (Gleitmo as described below) and is extremely resistant to fatigue.

Whenever used, this is specified in the instructions, and in such cases, *no other type of replacement screw* is allowed. Using other types of screws will void any warranty and may potentially cause serious damage or injury.

Gleitmo treated screws

Gleitmo is a special surface treatment to reduce the friction when tightening the screw joint. It is recommended by ABB for M6-M20 screw joints. Screws treated with Gleitmo may be reused 3-4 times before the coating disappears. After this the screw must be discarded and replaced with a new one.

When handling screws treated with Gleitmo, protective gloves of nitrile rubber type should be used.

Generally, screws are lubricated with *Gleitmo 603* mixed with *Geomet 500* or *Geomet 702* in proportion 1:3. *Geomet* thickness varies according to screw dimensions, refer to the following.

Dimension	Lubricant	Geomet thickness
M6-M20 (any length except M20x60)	<i>Gleitmo 603 + Geomet 500</i>	3-5 µm
M6-M20 (any length except M20x60)	<i>Gleitmo 603 + Geomet 720</i>	3-5 µm
M20x60	<i>Gleitmo 603 + Geomet 500</i>	8-12 µm
M20x60	<i>Gleitmo 603 + Geomet 720</i>	6-10 µm

Screws lubricated in other ways

Screws lubricated with Molykote 1000 or Molykote P1900 should *only* be used when specified in the repair, maintenance or installation procedure descriptions.

In such cases, proceed as follows:

- 1 Apply lubricant to the screw thread.
- 2 Apply lubricant between the plain washer and screw head.
- 3 Screw dimensions of M8 or larger must be tightened with a torque wrench. Screw dimensions of M6 or smaller may be tightened without a torque wrench *if* this is done by trained and qualified personnel.

Continues on next page

9 Reference information

9.4 Screw joints

Continued

Lubricant	Article number
Molykote 1000 (molybdenum disulphide grease)	3HAC042472-001
Molykote P1900 (molybdenum disulphide grease)	3HAC070875-001

Tightening torque

Before tightening any screw, note the following:

- Determine whether a **standard** tightening torque or **special** torque is to be applied. The **standard torques** are specified in the following tables. Any **special torques** are specified in the repair, maintenance or installation procedure descriptions. **Any special torque specified overrides the standard torque!**
- Use the *correct tightening torque* for each type of screw joint.
- Only use *correctly calibrated* torque keys.
- *Always tighten the joint by hand*, and never use pneumatic tools.
- Use the *correct tightening technique*, that is *do not* jerk. Tighten the screw in a slow, flowing motion.
- Maximum allowed total deviation from the specified value is **10%!**

Tightening torque for oil-lubricated screws with slotted or cross-recess head screws

The following table specifies the recommended standard tightening torque for *oil-lubricated screws with slotted or cross-recess head screws*.



Note

A special torque specified in the repair, maintenance or installation procedure overrides the standard torque.

Tightening torque for oil-lubricated screws with allen head screws

The following table specifies the recommended standard tightening torque for *oil-lubricated screws with allen head screws*.



Note

A special torque specified in the repair, maintenance or installation procedure overrides the standard torque.

Dimension	Tightening torque (Nm) Class 8.8, oil-lubricated	Tightening torque (Nm) Class 10.9, oil-lubricated	Tightening torque (Nm) Class 12.9, oil-lubricated
M5	6	-	-
M6	10	-	-
M8	24	34	40
M10	47	67	80
M12	82	115	140
M16	200	290	340
M20	400	560	670

Continues on next page

Dimension	Tightening torque (Nm) Class 8.8, oil-lubricated	Tightening torque (Nm) Class 10.9, oil-lubricated	Tightening torque (Nm) Class 12.9, oil-lubricated
M24	680	960	1150

Tightening torque for lubricated screws (Molykote, Gleitmo or equivalent) with allen head screws
The following table specifies the recommended standard tightening torque for screws lubricated with Molycote 1000, Gleitmo 603 or equivalent with allen head screws.



Note

A special torque specified in the repair, maintenance or installation procedure overrides the standard torque.

Dimension	Tightening torque (Nm) Class 10.9, lubricated ⁱ	Tightening torque (Nm) Class 12.9, lubricated ⁱ
M5		8
M6		14
M8	28	35
M10	55	70
M12	96	120
M16	235	300
M20	460	550
M24	790	950

ⁱ Lubricated with Molycote 1000, Gleitmo 603 or equivalent

9 Reference information

9.5 Weight specifications

9.5 Weight specifications

Definition

In installation, repair, and maintenance procedures, weights of the components handled are sometimes specified. All components exceeding 22 kg (50 lbs) are highlighted in this way.

To avoid injury, ABB recommends the use of a lifting accessory when handling components with a weight exceeding 22 kg. A wide range of lifting accessories and devices are available for each manipulator model.

Example

Following is an example of a weight specification in a procedure:

	Action	Note
	 CAUTION The arm weighs 25 kg. All lifting accessories used must be sized accordingly.	

9.6 Standard toolkit

General

All service (repairs, maintenance, and installation) procedures contains lists of tools required to perform the specified activity.

All special tools required are listed directly in the procedures while all the tools that are considered standard are gathered in the standard toolkit and defined in the following table.

This way, the tools required are the sum of the standard toolkit and any tools listed in the instruction.

Contents, standard toolkit

Qty	Tool	Rem.
1	Socket head cap 2-17 mm	
1	Torque wrench 0.3-45 Nm	
1	Torque wrench 50 Nm \pm 5 Nm	For securing robot to foundation.
1	Ratchet head for torque wrench 1/2	
1	Hex socket head cap no. 2.5 socket 1/2" bit L=110 mm	
1	Small screwdriver	
1	T-handle with ball head	
1	Small cutting plier	
1	Plastic mallet	
1	Needle-nose plier	

9 Reference information

9.7 Special tools

9.7 Special tools

General

All service instructions contain lists of tools required to perform the specified activity. The required tools are a sum of standard tools, defined in the section [Standard toolkit on page 733](#), and of special tools, listed directly in the instructions and also gathered in this section.

Special tools



Note

If the replacing procedure is not listed in the table below, only standard tools are needed for the procedure.

Tools and equipment with spare part number: (These tools can be ordered from ABB)	
-	24 VDC power supply
3HAC074119-001	Calibration tool box, Axis Calibration Delivered as a set of calibration tools. Required if Axis Calibration is the valid calibration method for the robot. The tool box also includes a unique calibration pin for IRB 1100 to be fitted to the tool flange during calibration of axis 6.
-	Sonic tension meter Used for measuring the timing belt tension.
-	Dynamometer Used for measuring the timing belt tension.
3HAC074609-001	Radial sealing assembly tool set Used with protection class IP67 and protection type Clean Room. Used for the press-fitting of radial sealings. Includes three sets of radial sealing fitting tool for axis 1, axis 2 and axis 3.
3HAC071022-001	Special toolkit Includes J5.C2 connector assembly tool, brake release button assembly tool, axis-4 motor fitting tool and M3x25 eye bolt.

10 Spare parts

10.1 Spare part lists and illustrations

Location

Spare parts and exploded views are not included in the manual but delivered as a separate document for registered users on myABB Business Portal, www.abb.com/myABB.

**Tip**

All documents can be found via myABB Business Portal, www.abb.com/myABB.

This page is intentionally left blank

Index

A

Absolute Accuracy, calibration, 687
 allergenic material, 28
 aluminum
 disposal, 722
 ambient humidity
 operation, 43
 storage, 43
 ambient temperature
 operation, 43
 storage, 43
 assembly instructions, 51
 assessment of hazards and risks, 28
 Axis Calibration, 695
 calibration tool
 article number, 698, 703
 examining, 698
 installation position, 700
 overview of method, 695
 procedure on FlexPendant, 703, 711
 protective cover and protection plug, 700, 703

B

base
 replacing, 226
 batteries
 disposal, 722
 battery pack
 replacing, 111
 Brake power supply, faulty, 719
 brake releasing, 65
 brakes
 testing function, 35

C

cabinet lock, 29
 cable package
 lubricating, 109
 cable package, lower
 replacing, 176
 cable package, upper
 replacing, 127
 cabling between robot and controller, 83
 calibrating
 robot, 695
 roughly, 691
 calibrating robot, 695, 711
 calibration
 Absolute Accuracy type, 686
 rough, 691
 standard type, 686
 verification, 713
 when to calibrate, 688
 calibration, Absolute Accuracy, 687
 calibration manuals, 687
 calibration marks, 689
 calibration position
 jogging to, 714
 scales, 689
 calibration scales, 689
 CalibWare, 686
 carbon dioxide extinguisher, 29
 cleaning, 98
 climbing on robot, 31

Cold environments, 89
 connecting the robot and controller, cabling, 83
 copper
 disposal, 722

D

damaged bearings, 718
 dimensions
 robot, 73
 direction of axes, 690

E

environmental information, 722
 equipment, robot, 73
 ESD
 damage elimination, 49
 sensitive equipment, 49
 expected life, 97
 extender unit
 replacing, 426
 extra equipment, 73

F

faulty brake, 719
 fire extinguishing, 29
 fitting, equipment, 73
 FlexPendant
 jogging to calibration position, 714
 MoveAbsJ instruction, 714
 updating revolution counters, 694
 foundation
 requirements, 42

G

gearbox, axis-4
 replacing, 649
 gearbox, axis-3
 replacing, 630
 gearbox, axis-2
 replacing, 607
 gearbox, axis-1
 replacing, 555
 Gravity Alpha, 68
 Gravity Beta, 67
 grease, 31
 disposal, 722

H

hanging
 installed hanging, 28
 hazard levels, 19
 hazardous material, 722
 height
 installed at a height, 28
 hot gearbox oil, 717–718
 hot surfaces, 31
 housing
 replacing, 374
 HRA, 28
 humidity
 operation, 43
 storage, 43

I

information labels location, 101
 inspecting
 information labels, 101

- robot cabling, 103
- timing belts, 104
- installation
 - equipment, 73
- instructions for assembly, 51
- integrator responsibility, 28
- intervals for maintenance, 95

L

- labels
 - robot, 21
- lead
 - disposal, 722
- leaking sealing, 717
- lifting
 - robot, 58
- lifting accessory, 732
- limitation of liability, 17
- Lithium
 - disposal, 722
- loads on foundation, 40
- lock and tag, 29
- lower arm
 - replacing, 333
- lubricants, 31
- lubricating
 - cable package, 109

M

- maintenance intervals, 95
- maintenance schedule, 95
- mechanical stop
 - axis 1, 81
- mechanical stop location, 81
- motor, axis-6
 - replacing, 543
- motor, axis-5
 - replacing, 531
- motor, axis-4
 - replacing, 518
- motor, axis-3
 - replacing, 505
- motor, axis-2
 - replacing, 491
- motor, axis-1
 - replacing, 473
- mounting, equipment, 73
- MoveAbsJ instruction, 714

N

- national regulations, 28
- negative directions, axes, 690
- neodymium
 - disposal, 722
- noise, 718

O

- oil, 31
 - disposal, 722
- oil leaks, 717
- operating conditions, 43
- original spare parts, 17
- overfilled gearbox, 717

P

- pedestal
 - installed on pedestal, 28

- personnel
 - requirements, 18
- plastic
 - disposal, 722
- positive directions, axes, 690
- PPE, 18
- product standards, 726
- protection classes, 43
- protection type, 43
- protective equipment, 18
- protective wear, 18

R

- recycling, 722
- regional regulations, 28
- release brakes, 34
- replacements, report, 119
- replacing
 - base, 226
 - battery pack, 111
 - cable package
 - lower, 176
 - upper, 127
 - extender unit, 426
 - gearbox
 - axis-4, 649
 - axis-3, 630
 - axis-2, 607
 - axis-1, 555
 - housing, 374
 - lower arm, 333
 - mechanical stop
 - axis 1, 81
 - motor
 - axis-6, 543
 - axis-5, 531
 - axis-4, 518
 - axis-3, 505
 - axis-2, 491
 - axis-1, 473
 - SMB unit, 217
 - swing, 276
 - wrist, 426
 - xx, 53
- report replacements, 119
- requirements on foundation, 42
- responsibility and validity, 17
- revolution counters
 - storing on FlexPendant, 694
 - updating, 691
- risk of burns, 31
- robot
 - dimensions, 73
 - equipment, fitting, 73
 - labels, 21
 - lifting, 58
 - protection class, 43
 - protection types, 43
 - symbols, 21
 - technical data, 40
 - working range, 46
- robot cabling
 - inspecting, 103
- rubber
 - disposal, 722

S

safety
 brake testing, 35
 ESD, 49
 fire extinguishing, 29
 release robot axes, 34
 signals, 19
 signals in manual, 19
 symbols, 19
 symbols on robot, 21
 test run, 91
safety devices, 29
safety signals
 in manual, 19
safety standards, 726
scales on robot, 689
schedule of maintenance, 95
screw joints, 729
securing, robot, 61
securing the robot to foundation, attachment screws, 61
shipping, 721
signals
 safety, 19
SMB unit
 replacing, 217
speed
 adjusting, 89
standards, 726
 ANSI, 726
 CAN, 726
start of robot in cold environments, 89
steel
 disposal, 722
storage conditions, 43
suspended mounting, 67
swing
 replacing, 276
symbols
 safety, 19
synchronization position, 691
sync marks, 689
system integrator requirements, 28
system parameter
 Gravity Alpha, 68
 Gravity Beta, 67

T

technical data
 robot, 40
temperatures
 operation, 43
 storage, 43
testing
 brakes, 35
timing belts
 inspecting, 104
torques on foundation, 40
transportation, 721
troubleshooting
 safety, 36
turning radius, 48

U

upcycling, 722
updating revolution counters, 691
users
 requirements, 18

V

validity and responsibility, 17
velocity
 adjusting, 89
verifying calibration, 713

W

wall mounting, 67
weight, 40
 robot, 62
working range, 48
 robot, 46
wrist
 replacing, 426
Wrist Optimization
 overview of method, 711

X

xx
 replacing, 53

Z

zero position
 checking, 714



ABB AB

Robotics & Discrete Automation

S-721 68 VÄSTERÅS, Sweden

Telephone +46 10-732 50 00

ABB AS

Robotics & Discrete Automation

Nordlysvegen 7, N-4340 BRYNE, Norway

Box 265, N-4349 BRYNE, Norway

Telephone: +47 22 87 2000

ABB Engineering (Shanghai) Ltd.

Robotics & Discrete Automation

No. 4528 Kangxin Highway

PuDong New District

SHANGHAI 201319, China

Telephone: +86 21 6105 6666

ABB Inc.

Robotics & Discrete Automation

1250 Brown Road

Auburn Hills, MI 48326

USA

Telephone: +1 248 391 9000

abb.com/robotics