

ROBOTICS

Product specification

IRB 1300



Trace back information:
Workspace 23C version a10
Checked in 2023-09-26
Skribenta version 5.5.019

Product specification

IRB 1300-11/0.9
IRB 1300-10/1.15
IRB 1300-7/1.4
IRB 1300-12/1.4

OmniCore

Document ID: 3HAC070393-001

Revision: M

The information in this manual is subject to change without notice and should not be construed as a commitment by ABB. ABB assumes no responsibility for any errors that may appear in this manual.

Except as may be expressly stated anywhere in this manual, nothing herein shall be construed as any kind of guarantee or warranty by ABB for losses, damage to persons or property, fitness for a specific purpose or the like.

In no event shall ABB be liable for incidental or consequential damages arising from use of this manual and products described herein.

This manual and parts thereof must not be reproduced or copied without ABB's written permission.

Keep for future reference.

Additional copies of this manual may be obtained from ABB.

Original instructions.

© Copyright 2020-2023 ABB. All rights reserved.
Specifications subject to change without notice.

Table of contents

Overview of this specification	7
1 Description	11
1.1 Structure	11
1.1.1 Introduction	11
1.1.2 Different robot versions	15
1.1.3 Definition of version designations	16
1.1.3.1 Technical data	16
1.1.3.2 Dimensions	20
1.1.3.3 Working range	23
1.2 Standards	29
1.2.1 Applicable standards	29
1.3 Installation	31
1.3.1 Introduction to installation	31
1.3.2 Operating requirements	32
1.3.3 Mounting the manipulator	33
1.4 Calibration and references	34
1.4.1 Calibration methods	34
1.4.2 Fine calibration	36
1.4.3 Absolute Accuracy calibration	37
1.4.4 Synchronization marks and axis movement directions	41
1.4.4.1 Synchronization marks and synchronization position for axes	41
1.5 Load diagrams	42
1.5.1 Introduction	42
1.5.2 Diagrams	43
1.5.3 Maximum load and moment of inertia for full and limited axis 5 (center line down) movement	51
1.5.4 Wrist torque	53
1.5.5 Maximum TCP acceleration	54
1.6 Fitting equipment on the robot (robot dimensions)	55
1.7 Maintenance and troubleshooting	60
1.8 Robot motion	61
1.8.1 Adjusting the working range	61
1.8.2 Mechanically restricting the working range	62
1.8.3 Performance according to ISO 9283	65
1.8.4 Velocity	66
1.9 Robot stopping distances and times	67
1.9.1 Robot stopping distances according to ISO 10218-1	67
1.9.2 Measuring stopping distance and time	71
1.9.3 IRB 1300 0.9 m 11 kg	73
1.9.4 IRB 1300 1.15 m 10 kg	82
1.9.5 IRB 1300 1.4 m 7 kg	91
1.9.6 IRB 1300 1.4 m 12 kg	100
1.10 Customer connections	109
2 Specification of variants and options	113
2.1 Introduction to variants and options	113
2.2 Manipulator	114
2.3 Floor cables	118
3 Accessories	121
Index	123

This page is intentionally left blank

Overview of this specification

About this product specification

This product specification describes the performance of the manipulator or a complete family of manipulators in terms of:

- The structure and dimensional prints
- The fulfilment of standards, safety, and operating equipment
- The load diagrams, mounting or extra equipment, the motion, and the robot reach
- The specification of available variants and options

The specification covers the manipulator using the OmniCore controller.

Usage

Product specifications are used to find data and performance about the product, for example to decide which product to buy. How to handle the product is described in the product manual.

The specification is intended for:

- Product managers and product personnel
- Sales and marketing personnel
- Order and customer service personnel

Usage

Product specifications are used to find data and performance about the product, for example to decide which product to buy. How to handle the product is described in the product manual.

The specification is intended for:

- Product managers and product personnel
- Sales and marketing personnel
- Order and customer service personnel

References

Documentation referred to in the manual, is listed in the table below.

Document name	Document ID
<i>Product manual - IRB 1300</i>	<i>3HAC070390-001</i>
<i>Product specification - OmniCore C line</i>	<i>3HAC065034-001</i>
<i>Product manual - OmniCore C30</i>	<i>3HAC060860-001</i>
<i>Product manual - OmniCore C90XT</i>	<i>3HAC073706-001</i>
<i>Product manual, spare parts - IRB 1300</i>	<i>3HAC070392-001</i>
<i>Circuit diagram - IRB 1300</i>	<i>3HAC068887-003</i>
<i>Product specification - OmniCore E line</i>	<i>3HAC079823-001</i>

Continues on next page

Overview of this specification

Continued

Revisions

Revision	Description
A	First edition.
B	Published in release 20D. The following updates are made in this revision: <ul style="list-style-type: none">• Restricted working range updated.• Max. Armload added.• Minor changes.• Warranty section updated.
C	Published in release 21A. The following updates are made in this revision: <ul style="list-style-type: none">• New protection added. 3350-670 Base 67, 3351-4 Cleanroom 4 and 3352-10 Foundry Plus2 67.• New option 209-2 ABB White std added.• Specification of connectors R1.C3 and R2.C3 is updated.• Type of R1.C3 connector, which is used for cable wiring, is added.• Maximum TCP acceleration added.
D	Published in release 21B. The following updates are made in this revision: <ul style="list-style-type: none">• Performance data according to ISO 9283 updated.• Modified the air hose diameter description.• Text regarding fastener quality is updated.• Updated the description of option 3303-1/3303-2.• Added a note to remind users that mechanical stop locations cannot be adjusted. See Adjusting the working range on page 61.• Absolute Accuracy calibration production data added.• Removed Axis resolution.• Added a note in manipulator protection chapter.
E	Published in release 21C. The following updates are done in this revision: <ul style="list-style-type: none">• Updated the tool flange standard figure for IP40, IP67 and Clean Room robots.• Supported controller OmniCore E10 is added.• Updated data for maximum axis speed.
F	Published in release 21D. The following updates are done in this revision: <ul style="list-style-type: none">• Add information that Clean room option is available for IP54 protection class.
G	Published in release 22A. The following updates are done in this revision: <ul style="list-style-type: none">• Added variant IRB 1300-12/1.4.• Updated the complete robot weight.• Update the graphic for robot cabling routing.• Added screwing depth information to attachment screws for robot foundation.
H	Published in release 22B. The following updates are done in this revision: <ul style="list-style-type: none">• Dimensions of tool flange with protection type Foundry Plus updated.• Angled type connector [3209-1] added.
J	Published in release 22C. The following updates are done in this revision: <ul style="list-style-type: none">• Added RAL code in manipulator color.• Updated power consumption.• Dimensions of tool flange with protection type IP40/IP67 updated.

Continues on next page

Revision	Description
K	<p>Published in release 22D. The following updates are done in this revision:</p> <ul style="list-style-type: none"> • The Maximum axis speed table updated to provide data related to OmniCore E10. • The Power consumption at max load table updated to provide data related to OmniCore E10. • Added Mains cable [3203-x]. • Diagram of IRB 1300-12/1.4 vertical wrist, Lmax updated.
L	<p>Published in release 23B. The following updates are done in this revision:</p> <ul style="list-style-type: none"> • Added a note for diagram of IRB 1300-12/1.4.
M	<p>Published in release 23C. The following updates are done in this revision:</p> <ul style="list-style-type: none"> • The updated robot stopping distances and times are moved to this document, and removed from the generic document, see Robot stopping distances and times on page 67. • Added new option 3303-3 Solenoid Valves Ext.

This page is intentionally left blank

1 Description

1.1 Structure

1.1.1 Introduction

General introduction for IRB 1300

The IRB 1300 is one of ABB Robotics latest generation of 6-axis industrial robot, with a payload of 7 kg, 10 kg, 11 kg and 12 kg designed specifically for manufacturing industries that use flexible robot-based automation, e.g. 3C industry. The robot has an open structure that is especially adapted for flexible use, and can communicate extensively with external systems.

Clean room classification



xx2000002547

Particle emission from the robot (IRB 1300 including gripper and suction cup) fulfill Clean room class 4 standard according to DIN EN ISO 14644-1, -14.

According to IPA test result, the robot IRB 1300 is suitable for use in clean room environments.

The manipulator is suitable for IP54 protection class according to standard IEC 60529 when customer choose clean room as an option.

IRB 1300 in Clean Room protection type is also suitable for working in requiring protection class IP54, as the robot is IP54 compliant according to standard IEC 60529.

Classification of airborne molecular contamination, see below:

Test environment parameters				
Cleanroom Air Cleanliness Class (According to ISO 14644-1)	Airflow velocity	Airflow pattern	Temperature	Relative humidity
ISO 1	0.45 m/s	vertical laminar flow	22°C ± 0.5°C	45% ± 0.5%

Test procedure parameters		
Velocity	Attached payload	Operation of each axis
50% and 100%	7 kg	separately

Test result/Classification:

Continues on next page

1 Description

1.1.1 Introduction

Continued

When operated under the specified test conditions, the IRB 1300 including gripper and suction cup is suitable for use in cleanrooms fulfilling the specifications of the following Air Cleanliness Classes according to ISO 14644-1.

Test parameter(s)	Air Cleanliness Class
Velocity=50%	2
Velocity=100%	4
Overall result	4

Protection type Foundry Plus 2

Robots with the option Foundry Plus 2 are designed for harsh environments where the robot is exposed to sprays of coolants, lubricants and metal spits that are typical for die casting applications or other similar applications.

Typical applications are spraying insertion and part extraction of die-casting machines, handling in sand casting and gravity casting, etc. (Please refer to Foundry Prime robots for washing applications or other similar applications). Special care must be taken in regard to operational and maintenance requirements for applications in foundry as well as in other applications areas. Please contact ABB Robotics Sales organization if in doubt regarding specific application feasibility for the Foundry Plus 2 protected robot.

The robot is painted with two-component epoxy on top of a primer for corrosion protection. To further improve the corrosion protection additional rust preventive are applied to exposed and crucial areas, e.g. has the tool flange a special preventive coating. Although, continuous splashing of water or other similar rust formation fluids may cause rust attach on the robots unpainted areas, joints, or other unprotected surfaces. Under these circumstances it is recommended to add rust inhibitor to the fluid or take other measures to prevent potential rust formation on the mentioned.

The entire robot is IP67 compliant according to IEC 60529 - from base to wrist, which means that the electrical compartments are sealed against water and solid contaminants. Among other things all sensitive parts are better protected than the standard offer.

Selected Foundry Plus 2 features:

- Improved sealing to prevent penetration into cavities to secure IP67
- Additional protection of cabling and electronics
- Special covers that protect cavities
- Well-proven connectors
- Additional stainless steel flange as extra protection
- Rust preventives on screws, washers and unpainted/machined surfaces
- Extended service and maintenance program

The Foundry Plus 2 robot can be cleaned with appropriate washing equipment according to the robot product manual. Appropriate cleaning and maintenance is

Continues on next page

required to maintain the protection, for example can rust preventive be washed off with wrong cleaning method.

Available robot variants

The option Foundry Plus 2 might not be available for all robot variants.

See [Specification of variants and options on page 113](#) for robot versions and other options not selectable together with Foundry Plus 2.

IP67 protection

The robot has IP67 as an option. The option will add sealing, machining parts and gasket.

Software product range

We have added a range of software products - all falling under the umbrella designation of Active Safety - to protect not only personnel in the unlikely event of an accident, but also robot tools, peripheral equipment and the robot itself.

Operating system

The robot is equipped with the OmniCore C30/C90XT/E10 controller and robot control software, RobotWare. RobotWare supports every aspect of the robot system, such as motion control, development and execution of application programs, communication etc. See *Operating manual - OmniCore*.

Safety

Safety standards valid for complete robot, manipulator and controller.

Additional functionality

For additional functionality, the robot can be equipped with optional software for application support - for example communication features - network communication - and advanced functions such as multitasking, sensor control etc. For a complete description on optional software, see the *Product specification - OmniCore C line* and *Product specification - OmniCore E line*.

Continues on next page

1 Description

1.1.1 Introduction

Continued

Robot axes

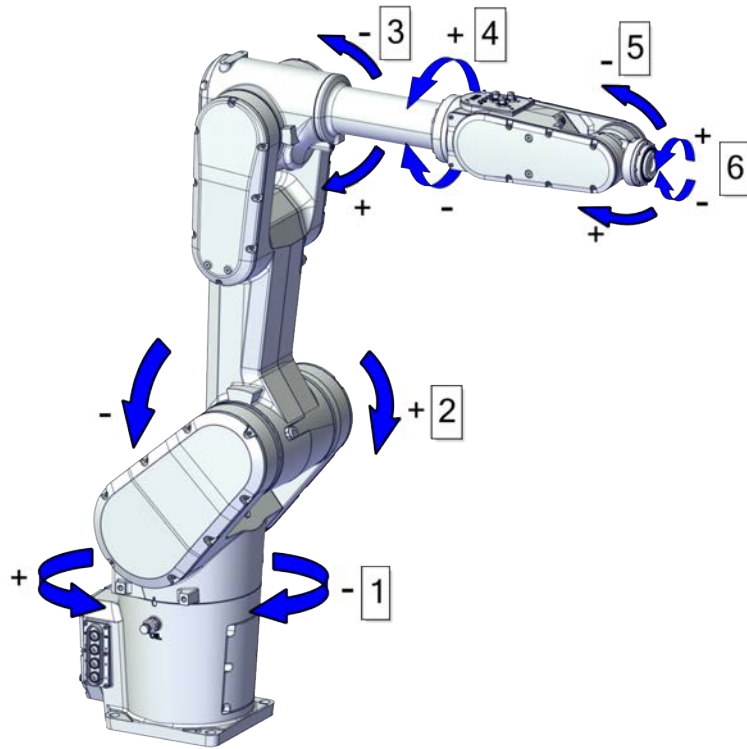

xx200000405

Pos	Description	Pos	Description
1	Axis 1	2	Axis 2
3	Axis 3	4	Axis 4
5	Axis 5	6	Axis 6

1.1.2 Different robot versions

General

The IRB 1300 is available in four versions.

Robot types

The following robot versions are available.

Robot type	Handling capacity (kg)	Reach (m)
IRB 1300-11/0.9	11 kg	0.9 m
IRB 1300-10/1.15	10 kg	1.15 m
IRB 1300-7/1.4	7 kg	1.4 m
IRB 1300-12/1.4	12 kg	1.4 m

1 Description

1.1.3.1 Technical data

1.1.3 Definition of version designations

1.1.3.1 Technical data

Weight, robot

The table shows the weight of the robot.

Robot model	Nominal weight
IRB 1300	IRB 1300-11/0.9: 75 kg IRB 1300-10/1.15: 77 kg IRB 1300-7/1.4: 79 kg IRB 1300-12/1.4: 79 kg



Note

The weight does not include additional options, tools and other equipment fitted on the robot.

Mounting positions

The table shows valid mounting positions and the installation (mounting) angle for the manipulator.

Mounting position	Installation angle
Floor mounted	Any angle
Wall mounted	Any angle
Suspended	Any angle



Note

The actual mounting angle must always be configured in the system parameters, otherwise the performance and lifetime is affected. See the product manual for details.

Loads on foundation, robot

The illustration shows the directions of the robots stress forces.

Continues on next page

The directions are valid for all floor mounted, suspended and wall mounted robots.

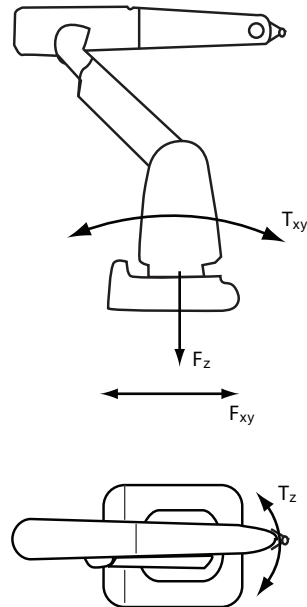

xx110000521

F_{xy}	Force in any direction in the XY plane
F_z	Force in the Z plane
T_{xy}	Bending torque in any direction in the XY plane
T_z	Bending torque in the Z plane

The table shows the various forces and torques working on the robot during different kinds of operation.



Note

These forces and torques are extreme values that are rarely encountered during operation. The values also never reach their maximum at the same time!



WARNING

The robot installation is restricted to the mounting options given in following load table(s).

Floor mounted

Force	Endurance load (in operation)	Maximum load (emergency stop)
Force xy	±821 N	±2186 N
Force z	428 N±1000 N	1547 N±1000 N
Torque xy	±814 Nm	±2392 Nm
Torque z	±236 Nm	±583 Nm

Continues on next page

1 Description

1.1.3.1 Technical data

Continued

Wall mounted

Force	Endurance load (in operation)	Max. load (emergency stop)
Force xy	±1478 N	±2860 N
Force z	±288 N	±963 N
Torque xy	±1068 Nm	±2741 Nm
Torque z	±352 Nm	±863 Nm

Suspended

Force	Endurance load (in operation)	Max. load (emergency stop)
Force xy	±821 N	±2186 N
Force z	428 N±1000 N	1547 N±1000 N
Torque xy	±814 Nm	±2392 Nm
Torque z	±236 Nm	±583 Nm

Requirements, foundation

The table shows the requirements for the foundation where the weight of the installed robot is included:

Requirement	Value	Note
Flatness of foundation surface	0.1/500 mm	<p>Flat foundations give better repeatability of the resolver calibration compared to original settings on delivery from ABB.</p> <p>The value for levelness aims at the circumstance of the anchoring points in the robot base.</p> <p>In order to compensate for an uneven surface, the robot can be recalibrated during installation. If resolver/encoder calibration is changed this will influence the absolute accuracy.</p>
Minimum resonance frequency	22 Hz  Note It may affect the manipulator lifetime to have a lower resonance frequency than recommended.	<p>The value is recommended for optimal performance.</p> <p>Due to foundation stiffness, consider robot mass including equipment.ⁱ</p> <p>For information about compensating for foundation flexibility, see the description of <i>Motion Process Mode</i> in the manual that describes the controller software option, see References on page 7.</p>
Minimum foundation material yield strength	150 MPa	

ⁱ The minimum resonance frequency given should be interpreted as the frequency of the robot mass/inertia, robot assumed stiff, when a foundation translational/torsional elasticity is added, i.e., the stiffness of the pedestal where the robot is mounted. The minimum resonance frequency should not be interpreted as the resonance frequency of the building, floor etc. For example, if the equivalent mass of the floor is very high, it will not affect robot movement, even if the frequency is well below the stated frequency. The robot should be mounted as rigid as possible to the floor.

Disturbances from other machinery will affect the robot and the tool accuracy. The robot has resonance frequencies in the region 10 – 20 Hz and disturbances in this region will be amplified, although somewhat damped by the servo control. This might be a problem, depending on the requirements from the applications. If this is a problem, the robot needs to be isolated from the environment.

Continues on next page

Storage conditions, robot

The table shows the allowed storage conditions for the robot:

Parameter	Value
Minimum ambient temperature	-25 °C (-13 °F) ⁱ
Maximum ambient temperature	+55 °C (+131 °F) ⁱⁱ
Maximum ambient temperature (less than 24 hrs)	+70 °C (+158 °F)
Maximum ambient humidity	95% at constant temperature (gaseous only) ⁱⁱⁱ

ⁱ For robots installed with solenoid valves (option 3303-3), the minimum allowed ambient temperature is -10 °C (14 °F).

ⁱⁱ For robots installed with solenoid valves (option 3303-3), the maximum allowed ambient temperature is +50 °C (+122 °F).

ⁱⁱⁱ For robots installed with solenoid valves (option 3303-3), the maximum allowed ambient humidity is 20% to 80% at constant temperature and no dew condensation allowed.

Operating conditions, robot

The table shows the allowed operating conditions for the robot:

Parameter	Value
Minimum ambient temperature	+5 °C ⁱ (41 °F)
Maximum ambient temperature	+45 °C (113 °F)
Maximum ambient humidity	95% at constant temperature ⁱⁱ

ⁱ At low environmental temperature (below 10 °C) a warm-up phase is recommended to be run with the robot. Otherwise there is a risk that the robot stops or runs with lower performance due to temperature dependent oil and grease viscosity.

ⁱⁱ For robots installed with solenoid valves (option 3303-3), the maximum allowed ambient humidity is 20% to 80% at constant temperature and no dew condensation allowed.

Protection classes, robot

The table shows the available protection types of the robot, with the corresponding protection class.

Protection type	Protection class ⁱ
Manipulator, protection type Standard	IP40 IP67 (option 3350-670)
Manipulator, protection type Foundry Plus 2	IP67
Manipulator, protection type Clean Room	ISO 4, IP54
Manipulator with solenoid valve (option)	IP40 IP67 (option 3350-670)

ⁱ According to IEC 60529.

Environmental information

The product complies with IEC 63000. *Technical documentation for the assessment of electrical and electronic products with respect to the restriction of hazardous substances.*

1 Description

1.1.3.2 Dimensions

1.1.3.2 Dimensions

Main dimensions of IRB 1300-11/0.9

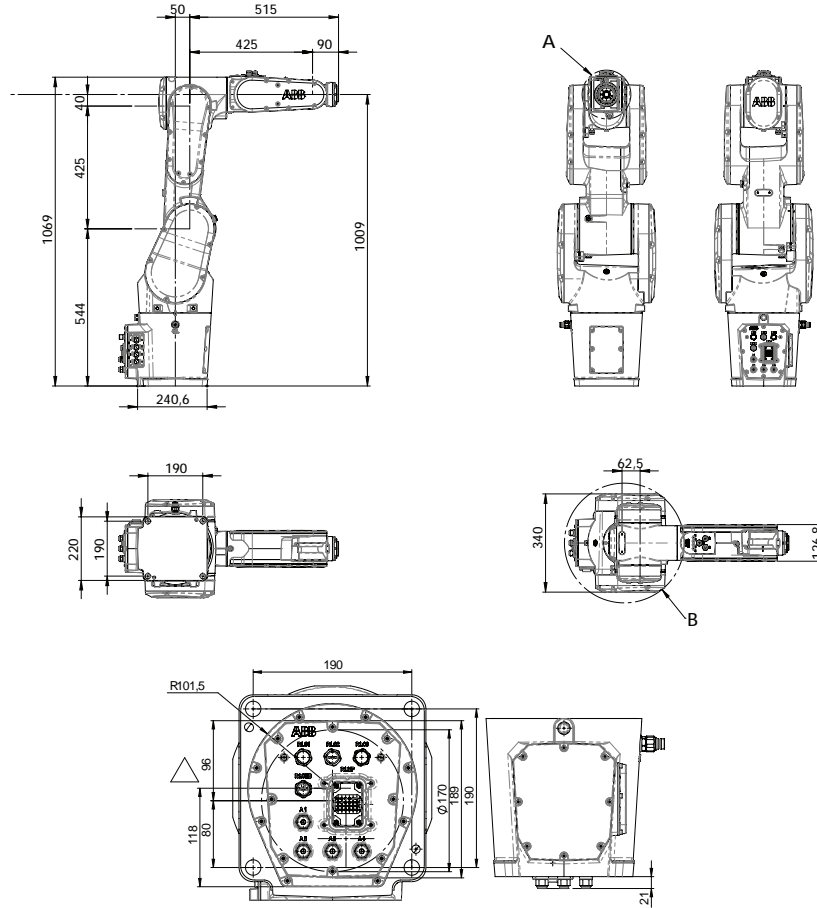

xx1900001331

Pos	Description
A	Turning radius: R84
B	Turning radius: R207

Continues on next page

Main dimensions of IRB 1300-10/1.15

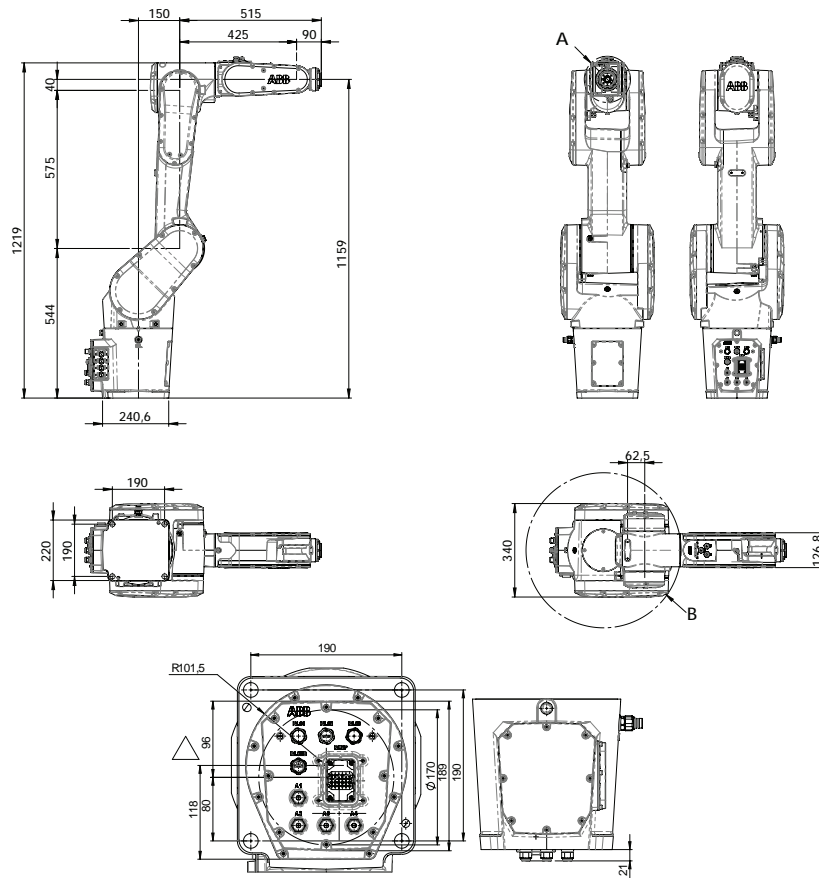

xx1900001332

Pos	Description
A	Turning radius: R84
B	Turning radius: R282

Continues on next page

1 Description

1.1.3.2 Dimensions

Continued

Main dimensions of IRB 1300-7/1.4 and IRB 1300-12/1.4

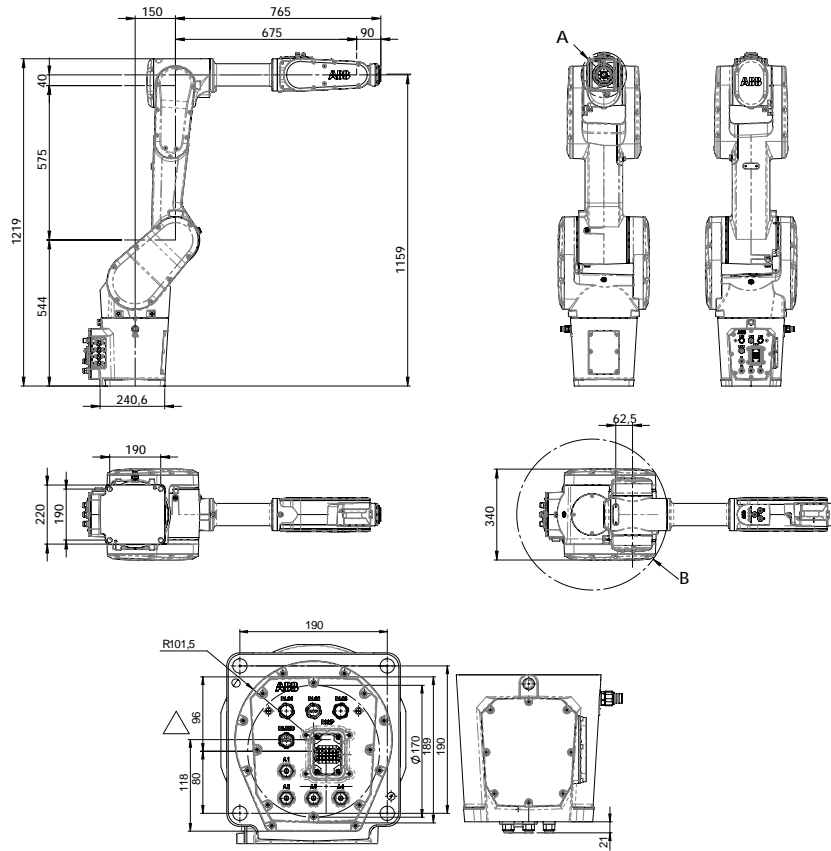

xx1900001333

Pos	Description
A	Turning radius: R84
B	Turning radius: R282

1.1.3.3 Working range

Illustration, working range IRB 1300-11/0.9

This illustration shows the unrestricted working range of the robot.

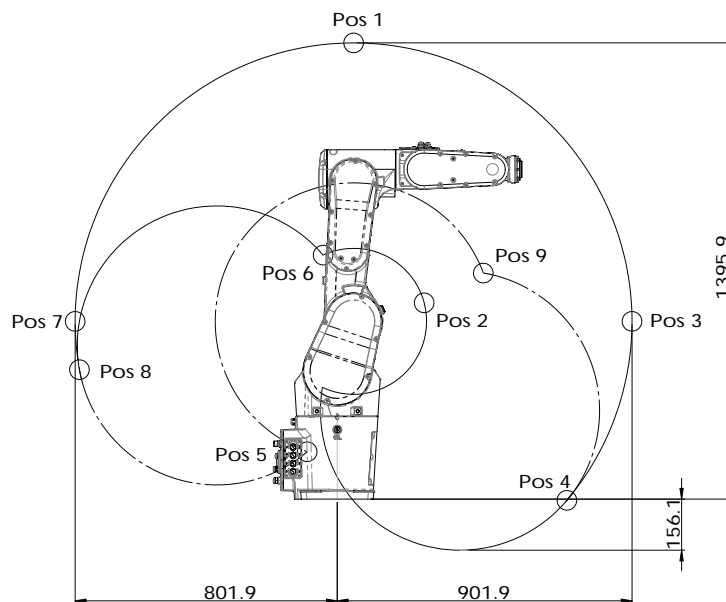

xx1900001334

Positions at wrist center and angle of axes 2 and 3

Position in the figure	Positions at wrist center (mm)		Angle (degrees)	
	X	Z	axis 2	axis 3
pos0	475	1009	0°	0°
pos1	50	1,395.9	0°	-84.6°
pos2	265.9	600.7	0°	65°
pos3	901.9	544	90°	-84.6°
pos4	702.6	-3.6	130°	-84.6°
pos5	-64.7	170.3	-100°	-210°
pos6	-43.3	746.7	-100°	65°
pos7	-801.9	544	-90°	-84.6°
pos8	-788.9	396.1	-100°	-84.6°
pos9	410	696.3	130°	-210°

Continues on next page

1 Description

1.1.3.3 Working range

Continued

Illustration, working range IRB 1300-10/1.15

This illustration shows the unrestricted working range of the robot.

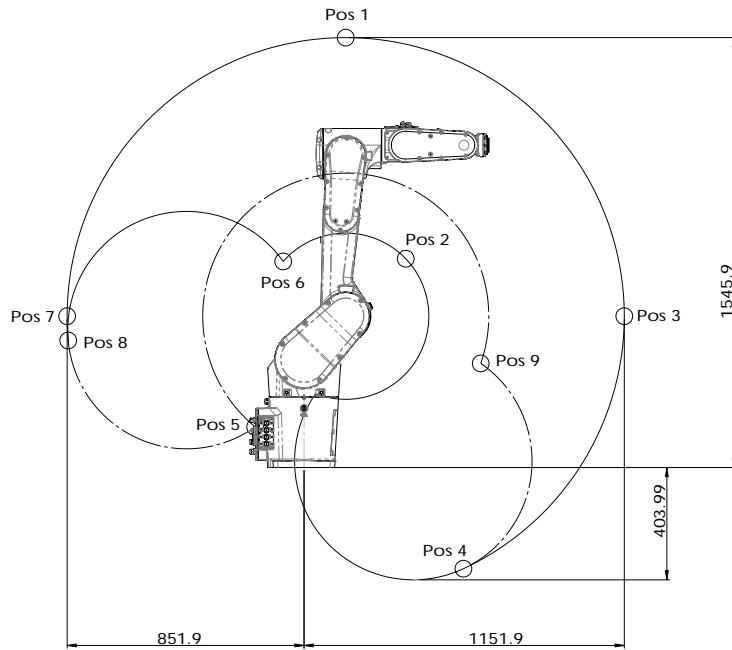

xx1900001335

Positions at wrist center and angle of axes 2 and 3

Position in the figure	Positions at wrist center (mm)		Angle (degrees)	
	X	Z	axis 2	axis 3
pos0	575	1159	0°	0°
pos1	150	1,545.9	0°	-84.6°
pos2	365.9	750.7	0°	65°
pos3	1,151.9	544	90°	-84.6°
pos4	573.4	-364	155°	-84.6°
pos5	-146.3	168.7	-95°	-210°
pos6	-74.8	741	-95°	65°
pos7	-851.9	544	-90°	-84.6°
pos8	-848.1	456.9	-95°	-84.6°
pos9	604	394	155°	-210°

Continues on next page

Illustration, working range IRB 1300-7/1.4

This illustration shows the unrestricted working range of the robot.

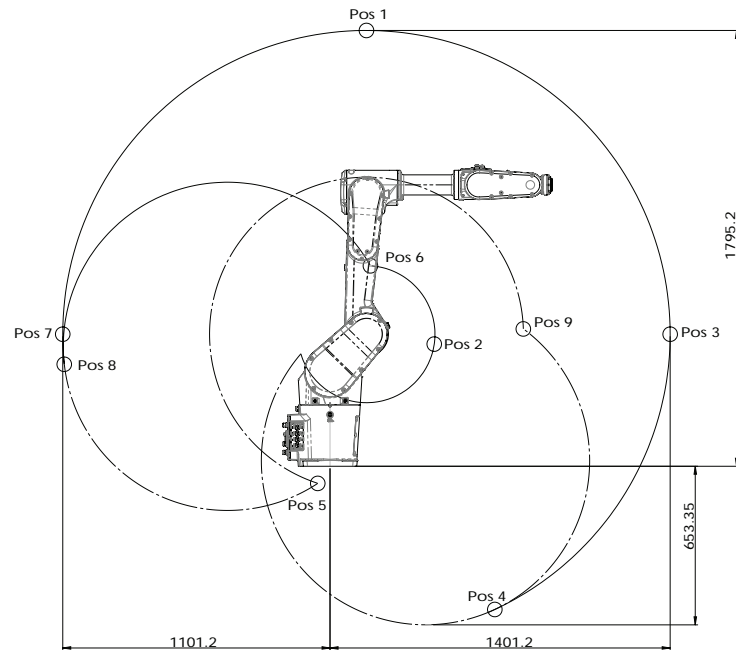

xx1900001336

Positions at wrist center and angle of axes 2 and 3

Position in the figure	Positions at wrist center (mm)		Angle (degrees)	
	X	Z	axis 2	axis 3
pos0	825	1159	0°	0°
pos1	150	1,795.2	0°	-86.6°
pos2	429.2	503.2	0°	69°
pos3	1,401.2	544	90°	-86.6°
pos4	678.8	-590	155°	-86.6°
pos5	-2.9	-36.1	-95°	-210°
pos6	166.3	825.7	-95°	69°
pos7	-1,101.2	544	-90°	-86.6°
pos8	-1,096.4	435	-95°	-86.6°
pos9	747.4	598.7	155°	-210°

Continues on next page

1 Description

1.1.3.3 Working range

Continued

Illustration, working range IRB 1300-12/1.4

This illustration shows the unrestricted working range of the robot.

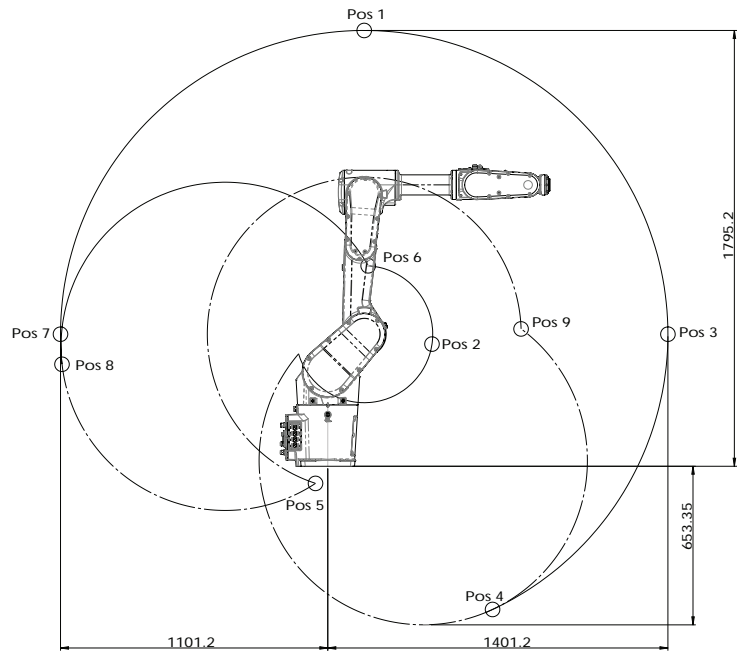

xx1900001336

Positions at wrist center and angle of axes 2 and 3

Position in the figure	Positions at wrist center (mm)		Angle (degrees)	
	X	Z	axis 2	axis 3
pos0	825	1159	0°	0°
pos1	150	1,795.2	0°	-86.6°
pos2	429.2	503.2	0°	69°
pos3	1,401.2	544	90°	-86.6°
pos4	678.8	-590	155°	-86.6°
pos5	-2.9	-36.1	-95°	-210°
pos6	166.3	825.7	-95°	69°
pos7	-1,101.2	544	-90°	-86.6°
pos8	-1,096.4	435	-95°	-86.6°
pos9	747.4	598.7	155°	-210°

Continues on next page

1 Description

1.1.3.3 Working range Continued

Top view of working range

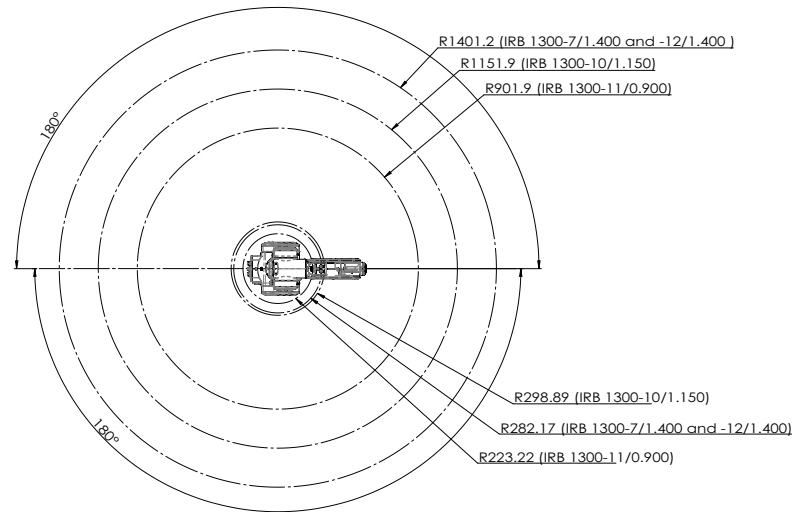

xx1900001341

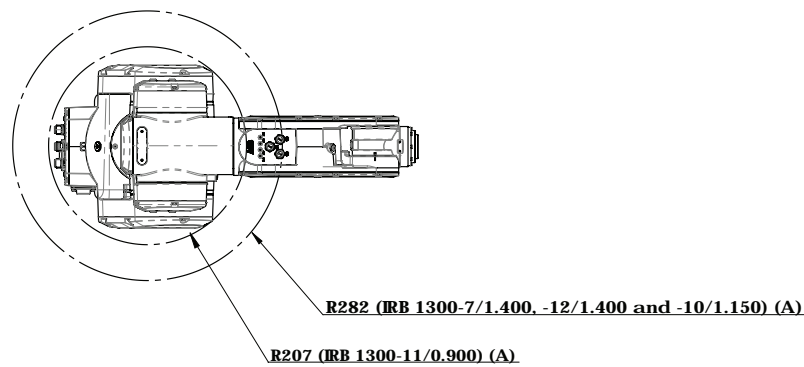

xx1900001342

Working range

Axis	Working range	Note
Axis 1	$\pm 180^\circ$	Wall mounted robot has a work area for axis 1 that depends on payload and the positions of other axes. Simulation in RobotStudio is recommended.
Axis 2	IRB 1300-10/1.15, IRB 1300-7/1.4 and IRB 1300-12/1.4 $-95^\circ/+155^\circ$ IRB 1300-11/0.9 $-100^\circ/+130^\circ$	
Axis 3	IRB 1300-7/1.4 and IRB 1300-12/1.4 $-210^\circ/+69^\circ$ IRB 1300-10/1.15 and IRB 1300-11/0.9 $-210^\circ/+65^\circ$	
Axis 4	$\pm 230^\circ$	

Continues on next page

1 Description

1.1.3.3 Working range

Continued

Axis	Working range	Note
Axis 5	±130°	
Axis 6	±400°	Default value.
	±242	Maximum revolution value. The default working range for axis 6 can be extended by changing parameter values in the software.

Other technical data

Data	Description	Note
Airborne noise level	The sound pressure level outside the working space.	< 70 dB(A) Leq (acc. to machinery directive 2006/42/EC)

Power consumption at max load

With OmniCore C line

Type of movement	11/0.9	10/1.15	7/1.4	12/1.4
ISO cube Max. velocity (W)	494	442	343	316
Robot in calibration position	11/0.9	10/1.15	7/1.4	12/1.4
Brakes engaged (W)	92	69	63	73
Brakes disengaged (W)	219	191	207	254

With OmniCore E line

Type of movement	11/0.9	10/1.15	7/1.4	12/1.4
ISO cube Max. velocity (W)	429	392	358	303
Robot in calibration position	11/0.9	10/1.15	7/1.4	12/1.4
Brakes engaged (W)	57	56	57	55
Brakes disengaged (W)	171	161	195	241

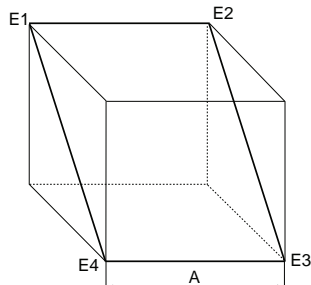

xx100000101

Pos	Description
A	400 mm

1.2 Standards

1.2.1 Applicable standards

General

The product is compliant with ISO 10218-1:2011, *Robots for industrial environments - Safety requirements - Part 1 Robots*, and applicable parts in the normative references, as referred to from ISO 10218-1:2011. In case of deviation from ISO 10218-1:2011, these are listed in the declaration of incorporation. The declaration of incorporation is part of the delivery.

Robot standards

Standard	Description
ISO 9283	Manipulating industrial robots – Performance criteria and related test methods
ISO 9787	Robots and robotic devices – Coordinate systems and motion nomenclatures
ISO 9946	Manipulating industrial robots – Presentation of characteristics

Other standards used in design

Standard	Description
IEC 60204-1	Safety of machinery - Electrical equipment of machines - Part 1: General requirements, normative reference from ISO 10218-1
IEC 61000-6-2	Electromagnetic compatibility (EMC) – Part 6-2: Generic standards – Immunity standard for industrial environments
IEC 61000-6-4	Electromagnetic compatibility (EMC) – Part 6-4: Generic standards – Emission standard for industrial environments
ISO 13849-1:2006	Safety of machinery - Safety related parts of control systems - Part 1: General principles for design, normative reference from ISO 10218-1
IEC 61340-5-1	Protection of electronic devices from electrostatic phenomena - General requirements

Region specific standards and regulations

Standard	Description
ANSI/RIA R15.06	Safety requirements for industrial robots and robot systems
ANSI/UL 1740	Safety standard for robots and robotic equipment
CAN/CSA Z 434-03	Industrial robots and robot Systems - General safety requirements
ANSI/ESD S20.20	Protection of Electrical and Electronic Parts, Assemblies and Equipment (Excluding Electrically Initiated Explosive Devices)
EN ISO 10218-1	Robots and robotic devices — Safety requirements for industrial robots — Part 1: Robots

Continues on next page

1 Description

1.2.1 Applicable standards

Continued

Deviations

Deviation for IRB 1300

The IRB 1300 does not provide means of installing adjustable mechanical stops on axis 1. Optional features provided by SafeMove, safety-rated soft axis and space limiting can be used as risk reduction measures in specific applications.

For details about SafeMove, see *Application manual - Functional safety and SafeMove*.

1.3 Installation

1.3.1 Introduction to installation

General

IRB 1300 is available in four variants and all variants can be floor mounted, inverted/suspended, wall mounted, or tilted mounted (any angle). Depending on the robot variant, an end effector with max. weight of 7 kg, 10 kg, 11 kg and 12 kg including payload, can be mounted on the tool flange (axis 6). See [Load diagrams on page 42](#).

Extra loads

The upper arm can handle an additional load of 0.5 kg (1 kg for reach 0.9m).

Working range limitation

The working range of axes 1 can be limited by mechanical stops as option. See [Working range on page 27](#).

1 Description

1.3.2 Operating requirements

1.3.2 Operating requirements

Protection standard

Robot variant	Protection standard IEC529
All variants, manipulator	IP40
Option, all variants	IP67

Explosive environments

The robot must not be located or operated in an explosive environment.

Working range limitations

EPS will not be selectable. No mechanical limitation.

Ambient temperature

Description	Protection class	Temperature
Manipulator during operation	Standard	+ 5 °C ⁱ (41 °F) to + 45 °C (113 °F)
For the controller	Standard/Option	See <i>Product specification - Omni-Core C line</i>
Complete robot during transportation and storage	Standard	- 25 °C (-13 °F) to + 55 °C (131 °F)
For short periods (not exceeding 24 hours)	Standard	up to + 70 °C (158 °F)

ⁱ At low environmental temperature < 10°C is, as with any other machine, a warm-up phase recommended to be run with the robot. Otherwise there is a risk that the robot stops or run with lower performance due to temperature dependent oil and grease viscosity.

Relative humidity

Description	Relative humidity
Complete robot during operation, transportation and storage	Max. 95% at constant temperature

1.3.3 Mounting the manipulator

Hole configuration, base

This illustration shows the hole configuration used when securing the robot.

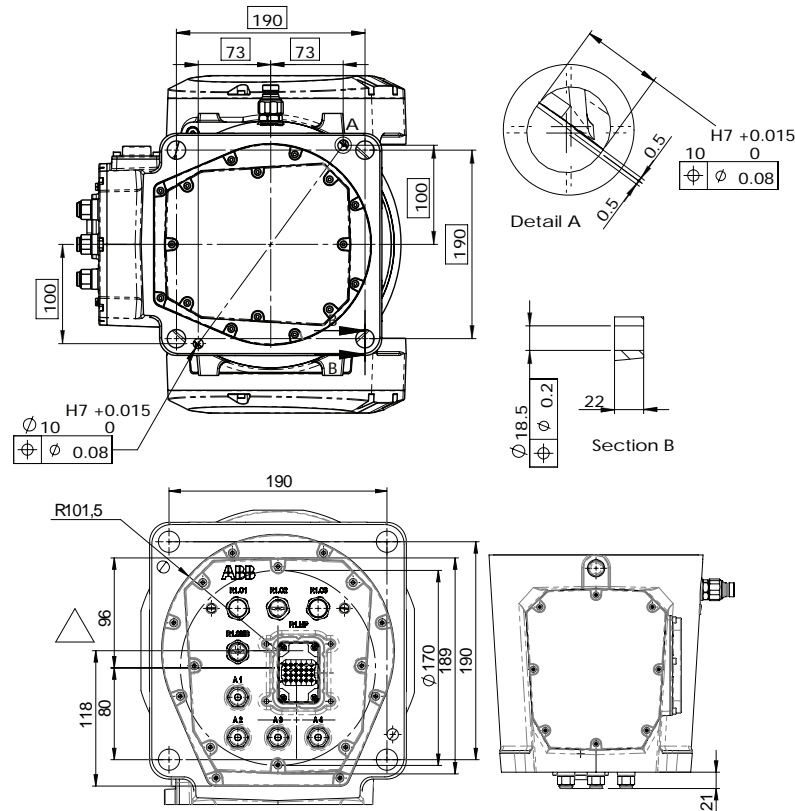

xx1900001337

Attachment screws

The table below specifies the type of securing screws and washers to be used for securing the robot to the base plate/foundation.

Suitable screws	M16x50
Quantity	4 pcs
Quality	8.8
Suitable washer	17 x 30 x 3, steel hardness class 200HV
Guide pins	2 pcs, D10x30, ISO 2338 - 10m6x30 - A1
Tightening torque	150 Nm±10 Nm
Length of thread engagement	Minimum 19 mm for ground with material yield strength 150 MPa
Level surface requirements	0.1/500 mm

1 Description

1.4.1 Calibration methods

1.4 Calibration and references

1.4.1 Calibration methods

Overview

This section specifies the different types of calibration and the calibration methods that are supplied by ABB.

The original calibration data delivered with the robot is generated when the robot is floor mounted. If the robot is not floor mounted, then the robot accuracy could be affected. The robot needs to be calibrated after it is mounted.

More information is available in the product manual.

Types of calibration

Type of calibration	Description	Calibration method
Standard calibration	The calibrated robot is positioned at calibration position. Standard calibration data is found on the SMB (serial measurement board) or EIB in the robot.	Axis Calibration
Absolute accuracy calibration (optional)	Based on standard calibration, and besides positioning the robot at synchronization position, the Absolute accuracy calibration also compensates for: <ul style="list-style-type: none">Mechanical tolerances in the robot structureDeflection due to load Absolute accuracy calibration focuses on positioning accuracy in the Cartesian coordinate system for the robot. Absolute accuracy calibration data is found on the serial measurement board (SMB) or other robot memory. A robot calibrated with Absolute accuracy has the option information printed on its name plate (OmniCore). To regain 100% Absolute accuracy performance, the robot must be recalibrated for absolute accuracy after repair or maintenance that affects the mechanical structure.	CalibWare
Optimization	Optimization of TCP reorientation performance. The purpose is to improve reorientation accuracy for continuous processes like welding and gluing. Wrist optimization will update standard calibration data for axes 4, 5 and 6.	Wrist Optimization

Brief description of calibration methods

Axis Calibration method

Axis Calibration is a standard calibration method for calibration of IRB 1300. It is the recommended method in order to achieve proper performance.

The following routines are available for the Axis Calibration method:

- Fine calibration

Continues on next page

- Update revolution counters
- Reference calibration

The calibration equipment for Axis Calibration is delivered as a toolkit.

The actual instructions of how to perform the calibration procedure and what to do at each step is given on the FlexPendant. You will be guided through the calibration procedure, step by step.

Wrist Optimization method

Wrist Optimization is a method for improving reorientation accuracy for continuous processes like welding and gluing and is a complement to the standard calibration method.

The actual instructions of how to perform the wrist optimization procedure is given on the FlexPendant.

CalibWare - Absolute Accuracy calibration

The CalibWare tool guides through the calibration process and calculates new compensation parameters. This is further detailed in the *Application manual - CalibWare Field*.

If a service operation is done to a robot with the option Absolute Accuracy, a new absolute accuracy calibration is required in order to establish full performance. For most cases after replacements that do not include taking apart the robot structure, standard calibration is sufficient.

The Absolute Accuracy option varies according to the robot mounting position. This is printed on the robot name plate for each robot. The robot must be in the correct mounting position when it is recalibrated for absolute accuracy.

1 Description

1.4.2 Fine calibration

1.4.2 Fine calibration

General

The fine calibration is done with the Axis calibration method.

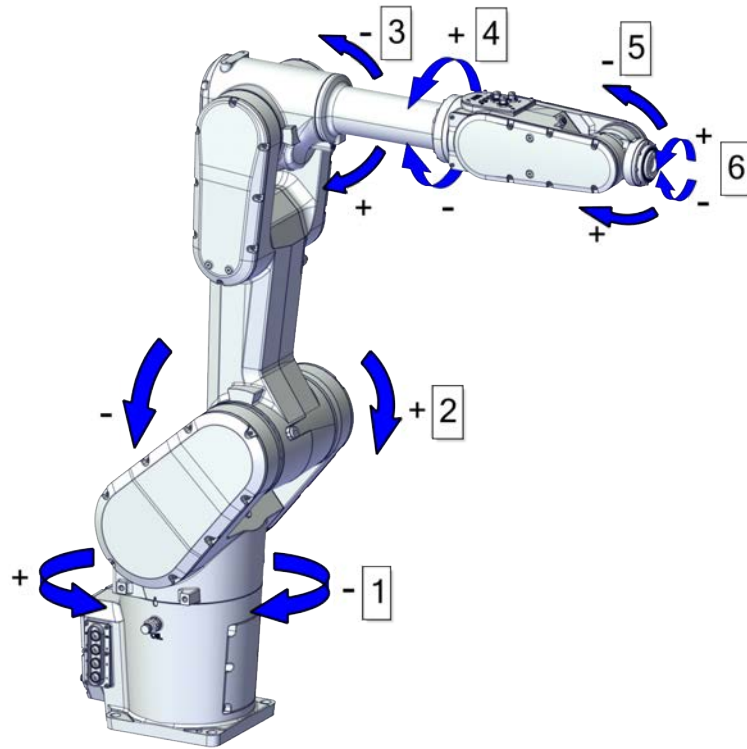

xx200000405

Axes

Pos	Description	Pos	Description
1	Axis 1	2	Axis 2
3	Axis 3	4	Axis 4
5	Axis 5	6	Axis 6

1.4.3 Absolute Accuracy calibration

Purpose

Absolute Accuracy is a calibration concept that improves TCP accuracy. The difference between an ideal robot and a real robot can be several millimeters, resulting from mechanical tolerances and deflection in the robot structure. *Absolute Accuracy* compensates for these differences.

Here are some examples of when this accuracy is important:

- Exchangeability of robots
- Offline programming with no or minimum touch-up
- Online programming with accurate movement and reorientation of tool
- Programming with accurate offset movement in relation to eg. vision system or offset programming
- Re-use of programs between applications

The option *Absolute Accuracy* is integrated in the controller algorithms and does not need external equipment or calculation.



Note

The performance data is applicable to the corresponding RobotWare version of the individual robot.

What is included

Every *Absolute Accuracy* robot is delivered with:

- compensation parameters saved in the robot memory
- a birth certificate representing the *Absolute Accuracy* measurement protocol for the calibration and verification sequence.

A robot with *Absolute Accuracy* calibration has a label with this information on the manipulator.

Absolute Accuracy supports floor mounted, wall mounted, and ceiling mounted installations. The compensation parameters that are saved in the robot memory differ depending on which *Absolute Accuracy* option is selected.

When is *Absolute Accuracy* being used

Absolute Accuracy works on a robot target in Cartesian coordinates, not on the individual joints. Therefore, joint based movements (e.g. `MoveAbsJ`) will not be affected.

If the robot is inverted, the *Absolute Accuracy* calibration must be performed when the robot is inverted.

Absolute Accuracy active

Absolute Accuracy will be active in the following cases:

- Any motion function based on robtargets (e.g. `MoveL`) and `ModPos` on robtargets
- Reorientation jogging

Continues on next page

1 Description

1.4.3 Absolute Accuracy calibration

Continued

- Linear jogging
- Tool definition (4, 5, 6 point tool definition, room fixed TCP, stationary tool)
- Work object definition

Absolute Accuracy not active

The following are examples of when Absolute Accuracy is not active:

- Any motion function based on a jointtarget (`MoveAbsJ`)
- Independent joint
- Joint based jogging
- Additional axes
- Track motion



Note

In a robot system with, for example, an additional axis or track motion, the Absolute Accuracy is active for the manipulator but not for the additional axis or track motion.

RAPID instructions

There are no RAPID instructions included in this option.

Production data

Typical production data regarding calibration are:

Robot	Positioning accuracy (mm)		
	Average	Max	% Within 1 mm
IRB 1300-11/0.9	0.15	0.30	100
IRB 1300-10/1.15	0.15	0.35	100
IRB 1300-7/1.4	0.20	0.40	100

Calibration tool

Check prior to usage

Before using the calibration tool, make sure that the tube insert, the plastic protection and the steel spring ring are present.



WARNING

If any part is missing or damaged, the tool must be replaced immediately.

Continues on next page

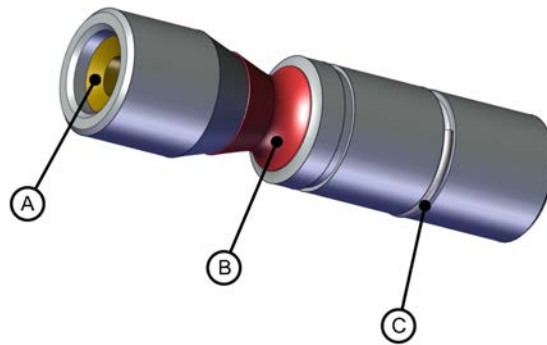

xx1500001914

A	Tube insert
B	Plastic protection
C	Steel spring ring

Periodic check of the calibration tool

If including the calibration tool in a local periodic check system, the following measures should be checked.

- Outer diameter within $\varnothing 12g4$ mm, $\varnothing 8g4$ mm or $\varnothing 6g5$ mm (depending on calibration tool size).
- Straightness within 0.005 mm.

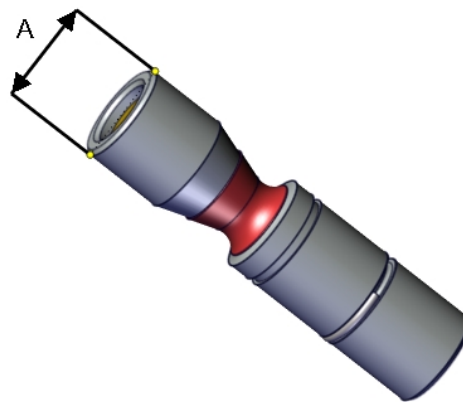

xx1500000951

A	Outer diameter
---	----------------

Periodic check of the calibration tool for the tool flange (3HAC058238-001)

If including the tool flange calibration tool in a local periodic check system, the following measures should be checked.

- Outer diameter within $\varnothing 5g5$ mm.
- Straightness within 0.005 mm.

Continues on next page

1 Description

1.4.3 Absolute Accuracy calibration

Continued

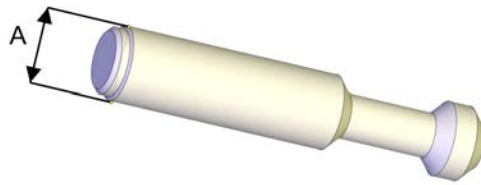

xx1600001142

A	Outer diameter
---	----------------

1.4.4 Synchronization marks and axis movement directions

1.4.4.1 Synchronization marks and synchronization position for axes

Introduction

This section shows the position of the synchronization marks and the synchronization position for each axis.

Synchronization marks, IRB 1300

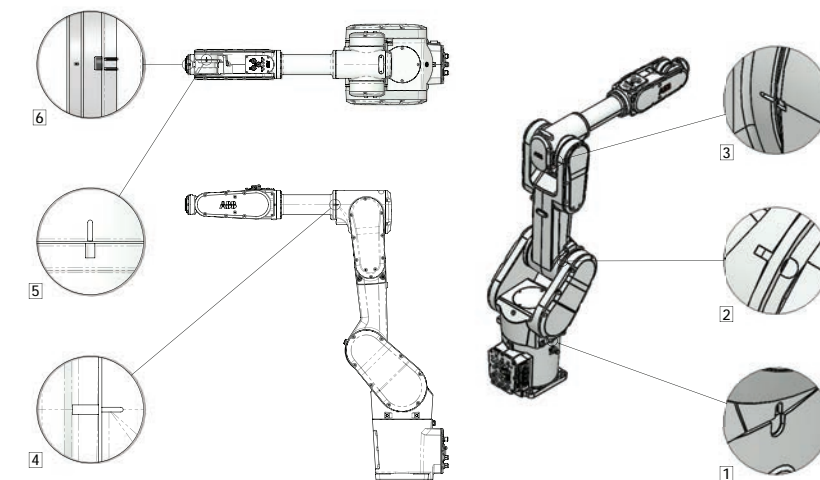

xx200000404

1 Description

1.5.1 Introduction

1.5 Load diagrams

1.5.1 Introduction



WARNING

It is very important to always define correct actual load data and correct payload of the robot. Incorrect definitions of load data can result in overloading of the robot.

If incorrect load data is used, and/or if loads outside the load diagram are used, the following parts can be damaged due to overload:

- motors
- gearboxes
- mechanical structure



WARNING

In RobotWare, the service routine LoadIdentify can be used to determine correct load parameters. The routine automatically defines the tool and the load.

See *Operating manual - OmniCore*, for detailed information.



WARNING

Robots running with incorrect load data and/or with loads outside the load diagram, will not be covered by robot warranty.

General

The load diagrams include a nominal payload inertia, J_0 of 0.012 kgm^2 , and an extra load of 0.5 kg (1 kg for reach 0.9m) at the upper arm housing.

At different moment of inertia the load diagram will be changed. For robots that are allowed tilted, wall or inverted mounted, the load diagrams as given are valid and thus it is also possible to use RobotLoad within those tilt and axis limits.

Control of load case with RobotLoad

To verify a specific load case, use the RobotStudio add-in RobotLoad.

The result from RobotLoad is only valid within the maximum loads and tilt angles. There is no warning if the maximum permitted arm load is exceeded. For over-load cases and special applications, contact ABB for further analysis.

1.5.2 Diagrams

IRB 1300-11/0.9

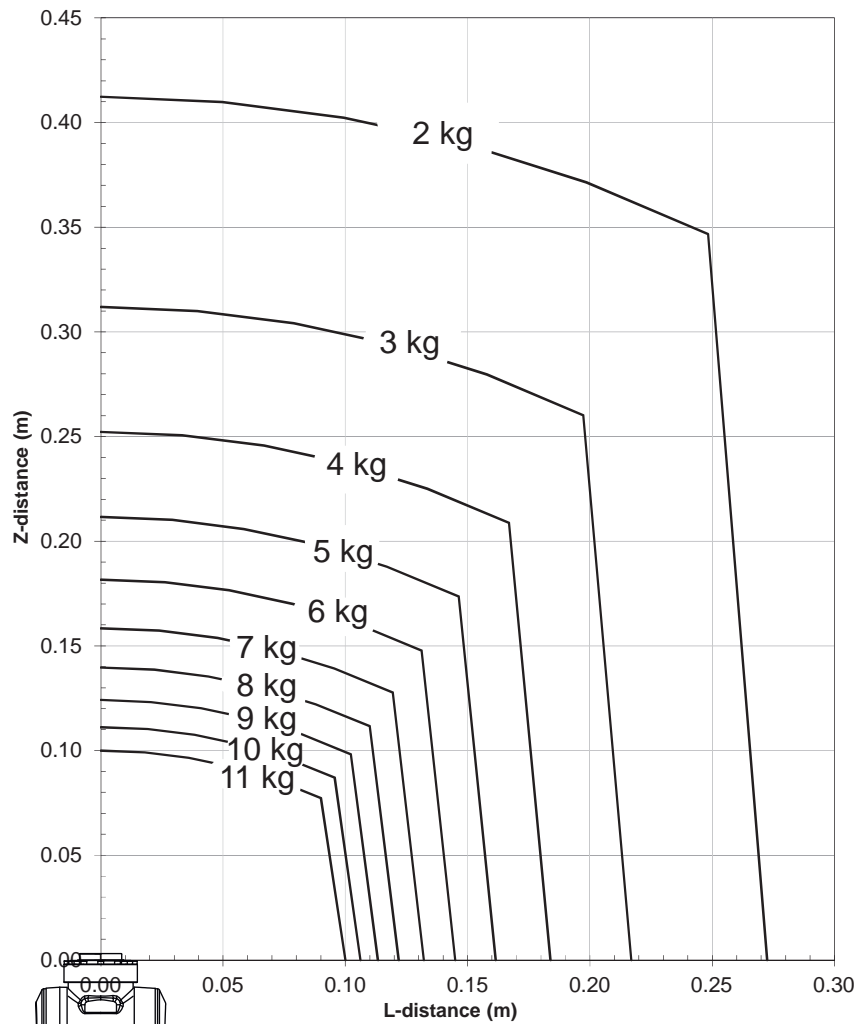

xx2000001095

Continues on next page

1 Description

1.5.2 Diagrams

Continued

IRB 1300-11/0.9 "Vertical Wrist" ($\pm 10^\circ$)

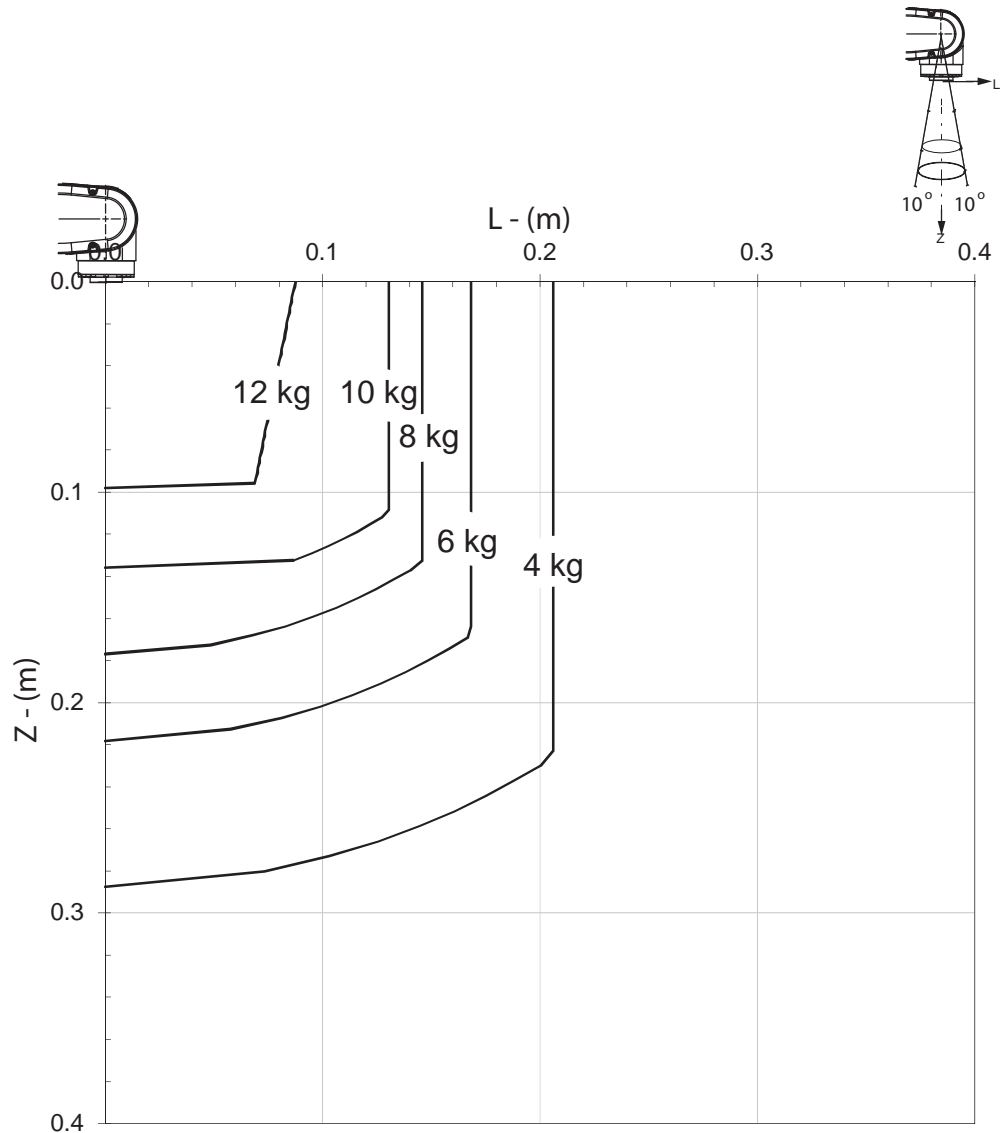

xx2000001102

For wrist down (0° deviation from the vertical line).

	Description
Max load	12 kg
Z _{max}	0.098 m
L _{max}	0.088 m

Continues on next page

IRB 1300-10/1.15

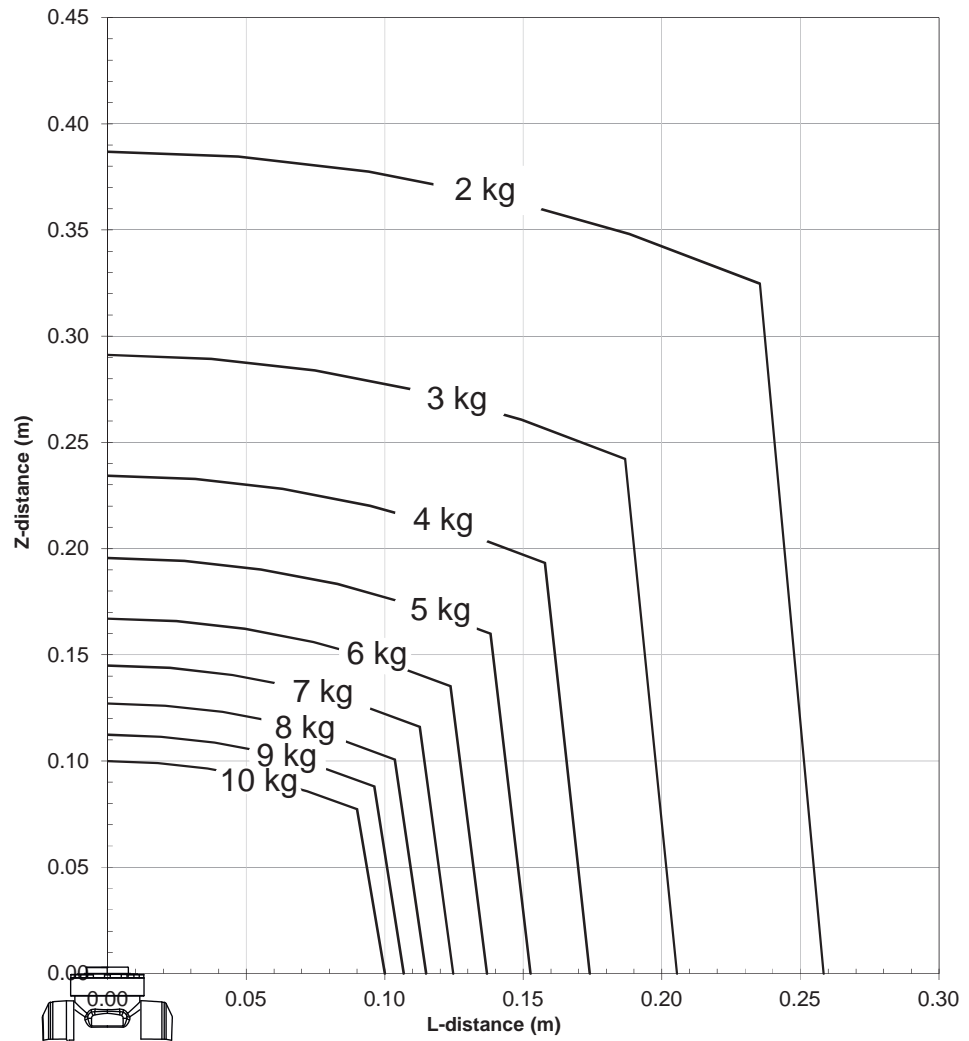

xx2000001094

Continues on next page

1 Description

1.5.2 Diagrams

Continued

IRB 1300-10/1.15 "Vertical Wrist" ($\pm 10^\circ$)

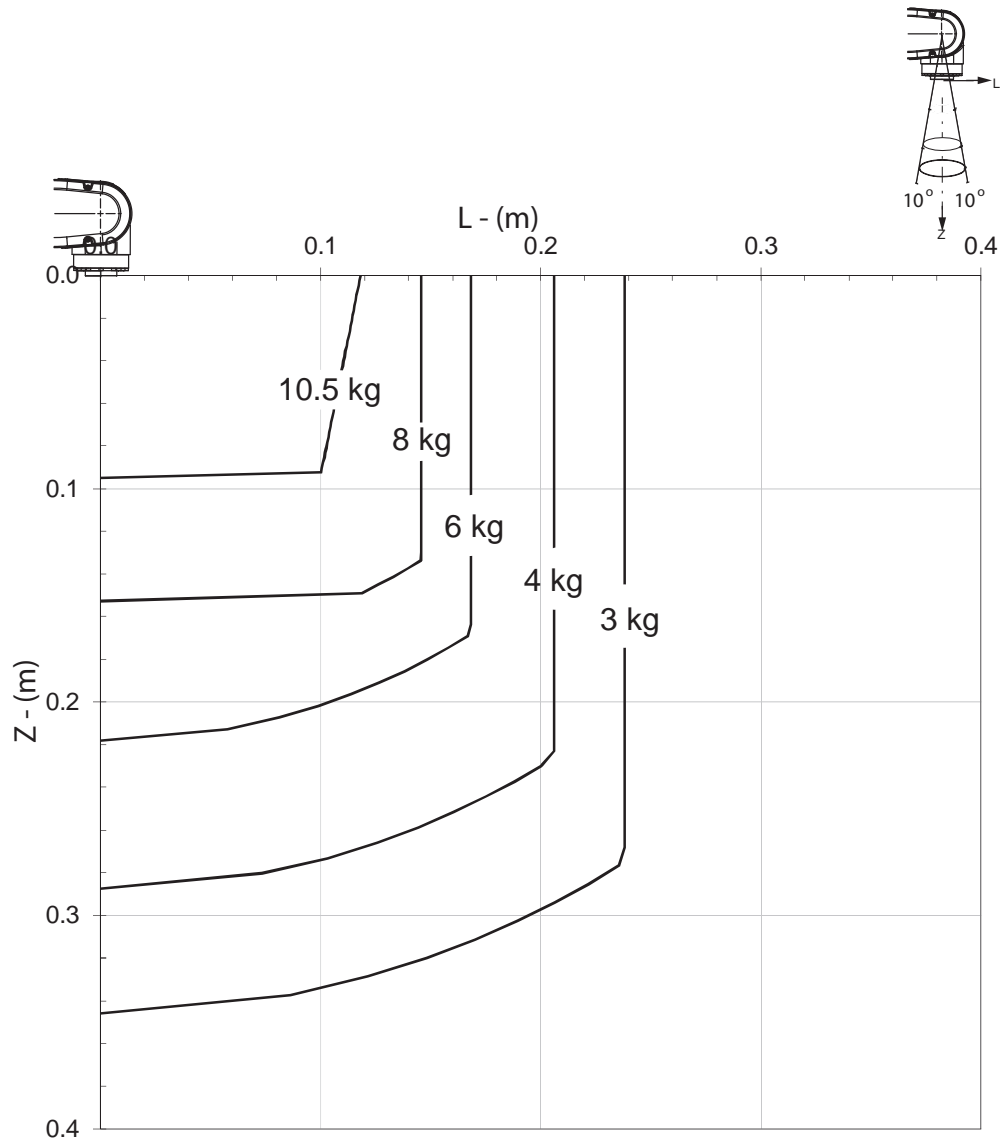

xx2000001101

For wrist down (0° deviation from the vertical line).

	Description
Max load	10.5 kg
Z _{max}	0.095 m
L _{max}	0.118 m

Continues on next page

IRB 1300-7/1.4

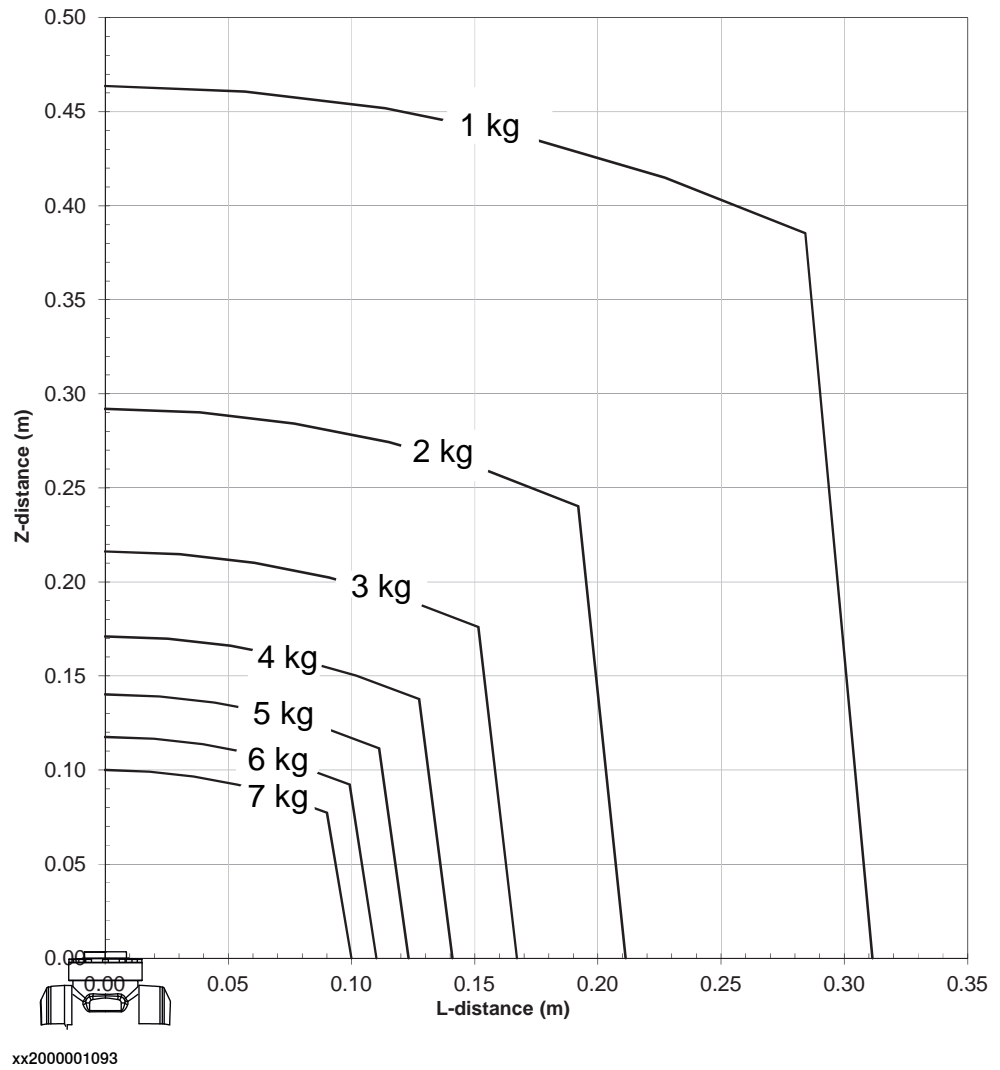

Continues on next page

1 Description

1.5.2 Diagrams

Continued

IRB 1300-7/1.4 "Vertical Wrist" ($\pm 10^\circ$)

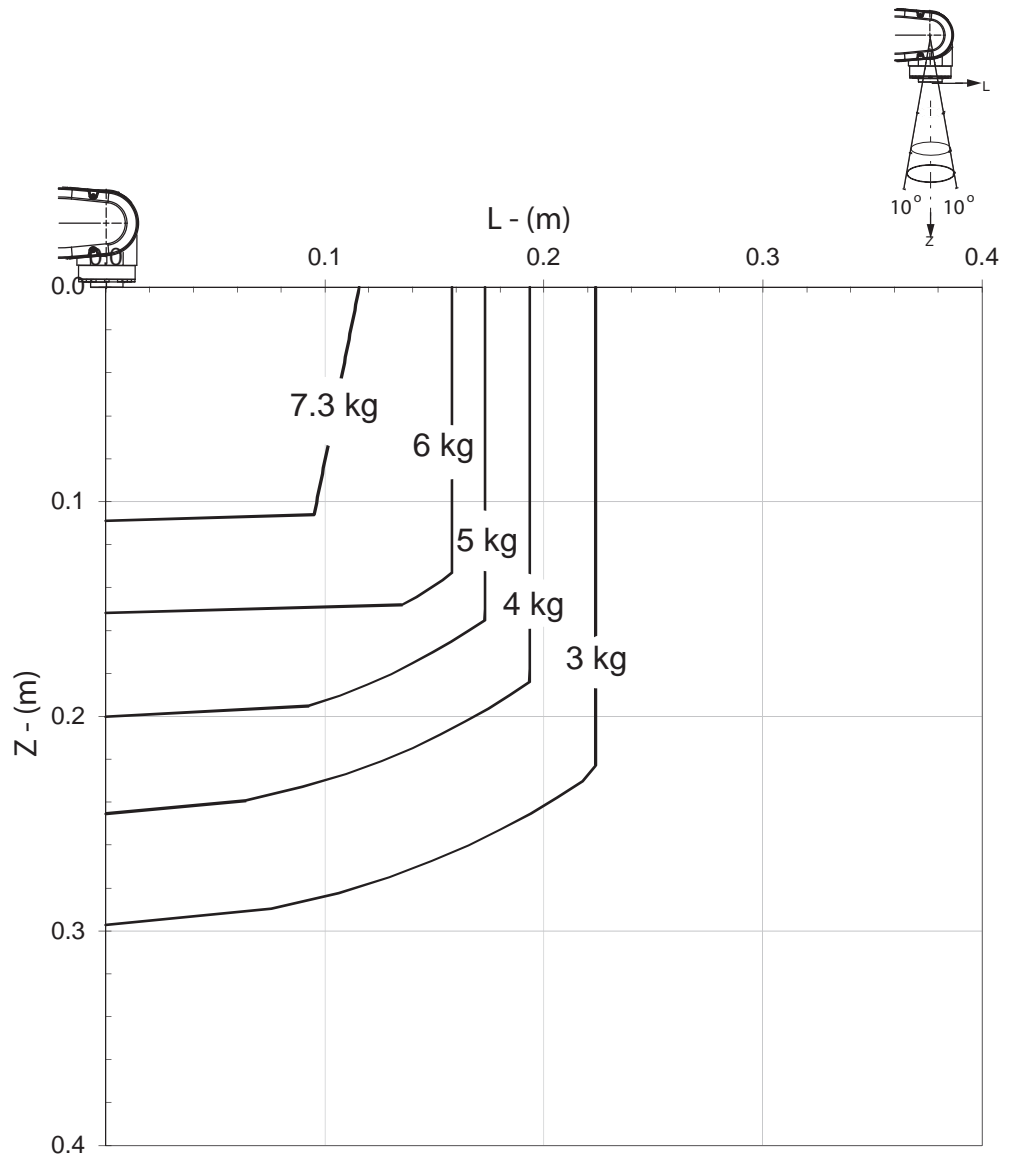

xx2000001100

For wrist down (0° deviation from the vertical line).

	Description
Max load	7.3 kg
Z _{max}	0.109 m
L _{max}	0.116 m

Continues on next page

IRB 1300-12/1.4



Note

Z value of Load diagram should shorten 2 mm for Foundry version.

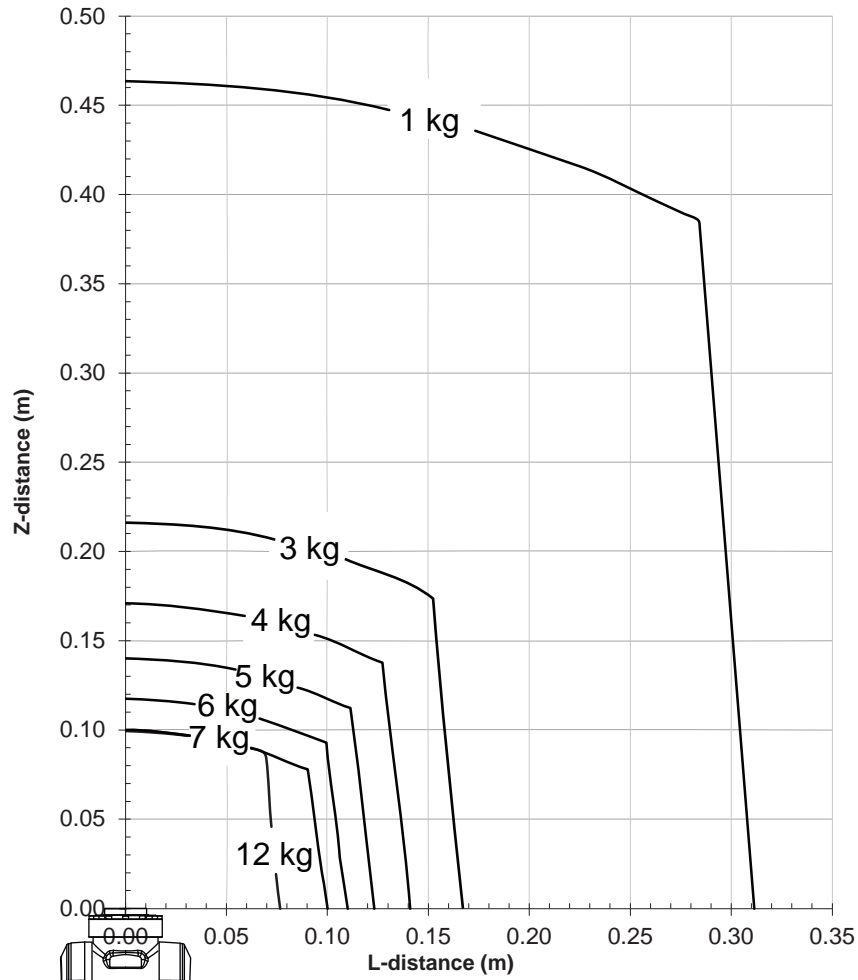

xx2100002863



Note

Robot uses "adaptive performance" to have higher load capacity with lower joint maximum speed. But load diagram only reflects payload capacity. Thus, lines can be overlapped, but the robot will act differently with different payload.

Continues on next page

1 Description

1.5.2 Diagrams

Continued

IRB 1300-12/1.4 "Vertical Wrist" ($\pm 10^\circ$)

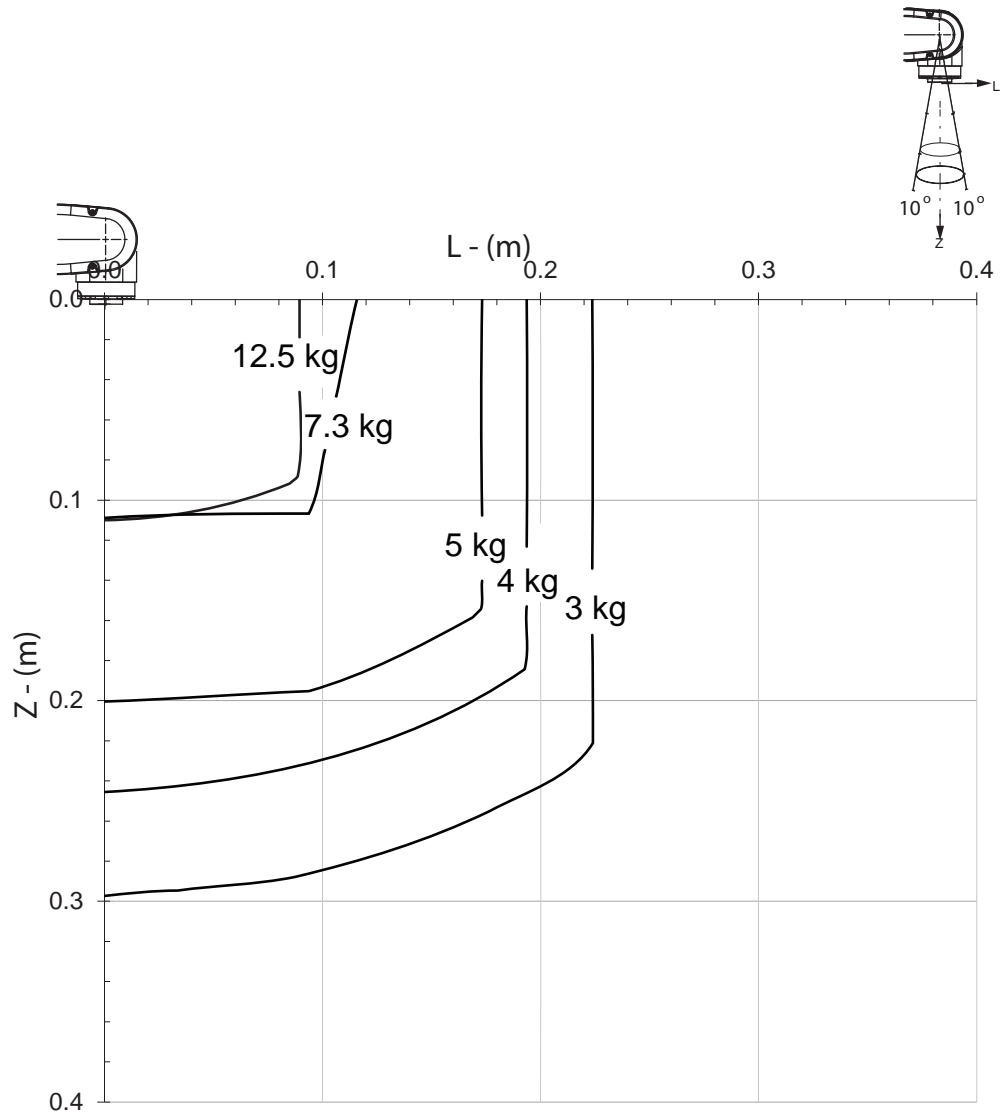

xx2100002864

For wrist down (0° deviation from the vertical line).

	Description
Max load	12.5 kg
Z_{\max}	0.11 m
L_{\max}	0.089 m

1.5.3 Maximum load and moment of inertia for full and limited axis 5 (center line down) movement

1.5.3 Maximum load and moment of inertia for full and limited axis 5 (center line down) movement



Note

Total load given as: mass in kg, center of gravity (Z and L) in meters and moment of inertia (J_{ox} , J_{oy} , J_{oz}) in kgm^2 . $L = \text{sqr}(X^2 + Y^2)$, see the following figure.

Full movement of axis 5 ($\pm 130^\circ$)

Axis	Robot type	Maximum moment of inertia
5	IRB 1300-11/0.9 IRB 1300-10/1.15 IRB 1300-12/1.4	$J_{a5} = \text{Load} \times ((Z + 0.09)^2 + L^2) + \max(J_{ox}, J_{oy}) \leq 0.6 \text{ kgm}^2$
5	IRB 1300-7/1.4	$J_{a5} = \text{Load} \times ((Z + 0.09)^2 + L^2) + \max(J_{ox}, J_{oy}) \leq 0.5 \text{ kgm}^2$
6	IRB 1300-11/0.9 IRB 1300-10/1.15 IRB 1300-7/1.4 IRB 1300-12/1.4	$J_{a6} = \text{Load} \times L^2 + J_{oz} \leq 0.2 \text{ kgm}^2$

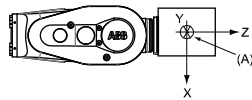

xx1400002028

Pos	Description
A	Center of gravity

	Description
J_{ox}, J_{oy}, J_{oz}	Max. moment of inertia around the X, Y and Z axes at center of gravity.

Continues on next page

1 Description

1.5.3 Maximum load and moment of inertia for full and limited axis 5 (center line down) movement Continued

Limited axis 5, center line down

Axis	Robot type	Maximum moment of inertia
5	IRB 1300-11/0.9 IRB 1300-10/1.15 IRB 1300-12/1.4	$J_{a_5} = \text{Load} \times ((Z + 0.09)^2 + L^2) + \max(J_{ox}, J_{oy}) \leq 0.6 \text{ kgm}^2$
5	IRB 1300-7/1.4	$J_{a_5} = \text{Load} \times ((Z + 0.09)^2 + L^2) + \max(J_{ox}, J_{oy}) \leq 0.5 \text{ kgm}^2$
6	IRB 1300-11/0.9 IRB 1300-10/1.15 IRB 1300-7/1.4 IRB 1300-12/1.4	$J_{a_6} = \text{Load} \times L^2 + J_{oz} \leq 0.2 \text{ kgm}^2$

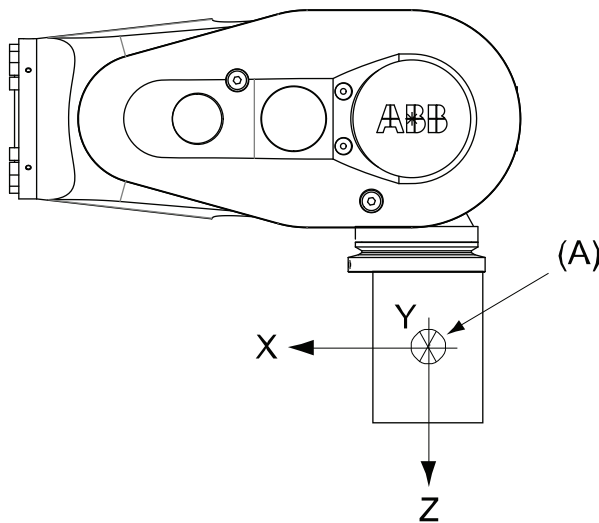

xx1400002029

Pos	Description
A	Center of gravity
	Description
J_{ox}, J_{oy}, J_{oz}	Max. moment of inertia around the X, Y and Z axes at center of gravity.

1.5.4 Wrist torque



Note

The wrist torque values are for reference only, and should not be used for calculating permitted load offset (position of center of gravity) within the load diagram, since those also are limited by main axes torques as well as dynamic loads. Furthermore, arm loads will influence the permitted load diagram. To find the absolute limits of the load diagram, use the RobotStudio add-in RobotLoad.

Torque

The table below shows the maximum permissible torque due to payload.

Robot type	Max wrist torque axis 4 and 5	Max wrist torque axis 6	Max torque valid at load
IRB 1300-11/0.9	20.45 Nm	10.8 Nm	11 kg
IRB 1300-10/1.15	18.59 Nm	9.8 Nm	10 kg
IRB 1300-7/1.4	13 Nm	6.9 Nm	7 kg
IRB 1300-12/1.4	21.6 Nm	9 Nm	12 kg

1 Description

1.5.5 Maximum TCP acceleration

1.5.5 Maximum TCP acceleration

General

Higher values can be reached with lower loads than the nominal because of our dynamical motion control QuickMove2. For specific values in the unique customer cycle, or for robots not listed in the table below, we recommend to use RobotStudio.

Maximum Cartesian design acceleration for nominal loads

Robot type	E-stop Max acceleration at nominal load COG [m/s ²]	Controlled Motion Max acceleration at nominal load COG [m/s ²]
IRB 1300-11/0.9	75	49.5
IRB 1300-10/1.15	68	50
IRB 1300-7/1.4	82	66
IRB 1300-12/1.4	54.4	36.5



Note

Acceleration levels for emergency stop and controlled motion includes acceleration due to gravitational forces. Nominal load is defined with nominal mass and cog with max offset in Z and L (see the load diagram).

1.6 Fitting equipment on the robot (robot dimensions)

Attachment holes and dimensions

Extra loads can be mounted on robot. Definitions of load area and permitted load are shown in figure below. The center of gravity of the extra load shall be within the marked load areas. Maximum allowed arm load depends on center of gravity of arm load and robot payload.

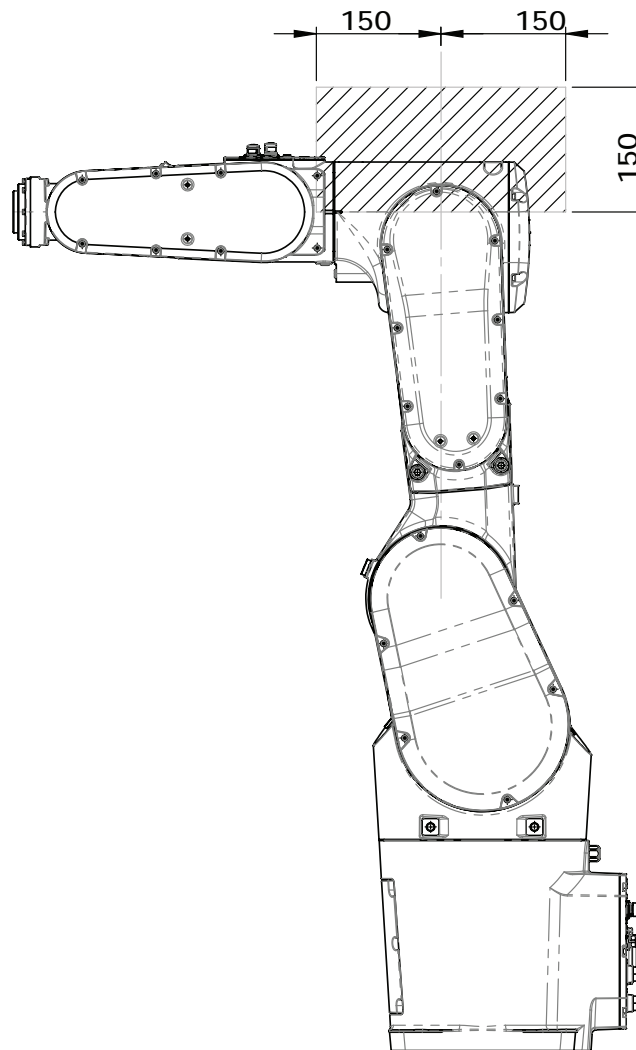

xx1900001599

Variant	Max. armload (kg)
IRB 1300-11/0.9	1
IRB 1300-10/1.15	0.5
IRB 1300-7/1.4	0.5
IRB 1300-12/1.4	0.5

Continues on next page

1 Description

1.6 Fitting equipment on the robot (robot dimensions)

Continued

Holes for fitting extra equipment

The robot is supplied with holes for fitting extra equipment, as shown in the following figures

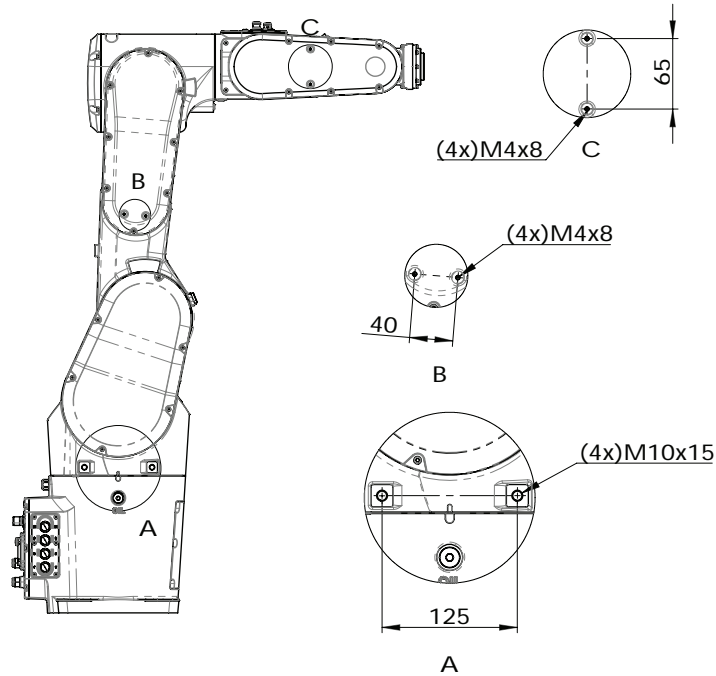

xx1900001338

Continues on next page

1.6 Fitting equipment on the robot (robot dimensions)

Continued

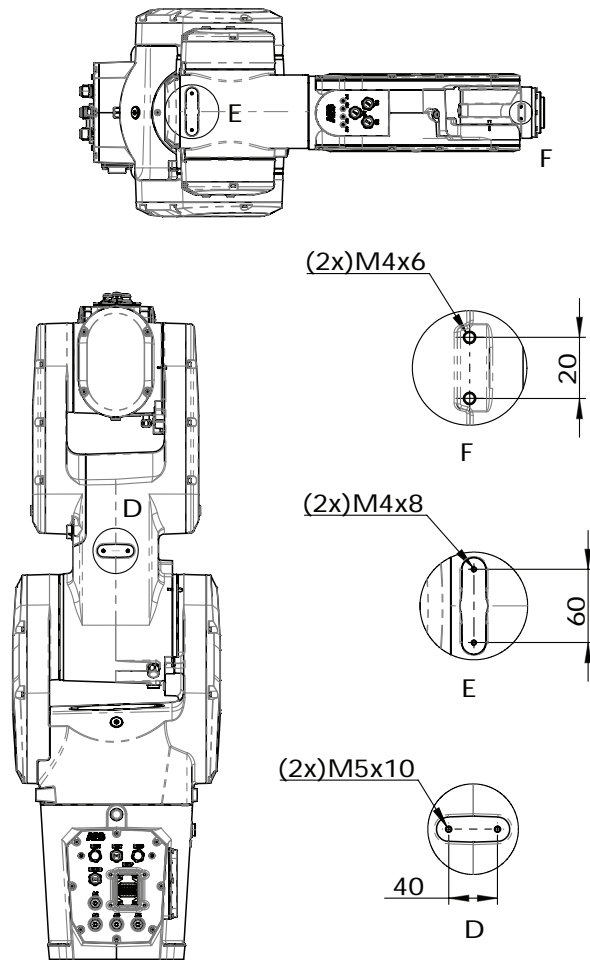

xx1900001339

Continues on next page

1 Description

1.6 Fitting equipment on the robot (robot dimensions)

Continued

Tool flange standard

For robots with protection classes IP40 and IP67, and with protection type Clean Room

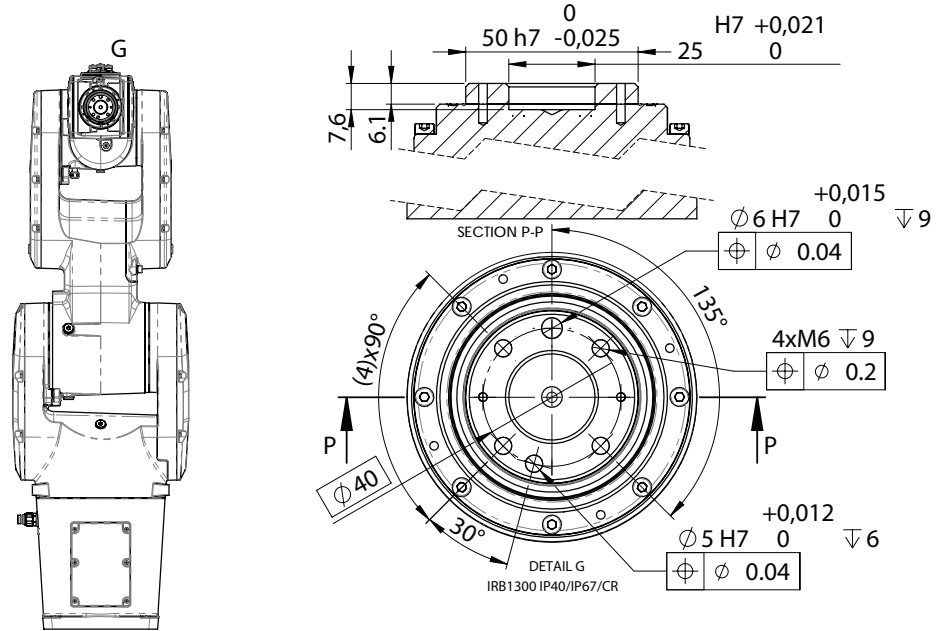

xx1900001340

For robots with protection type Foundry Plus

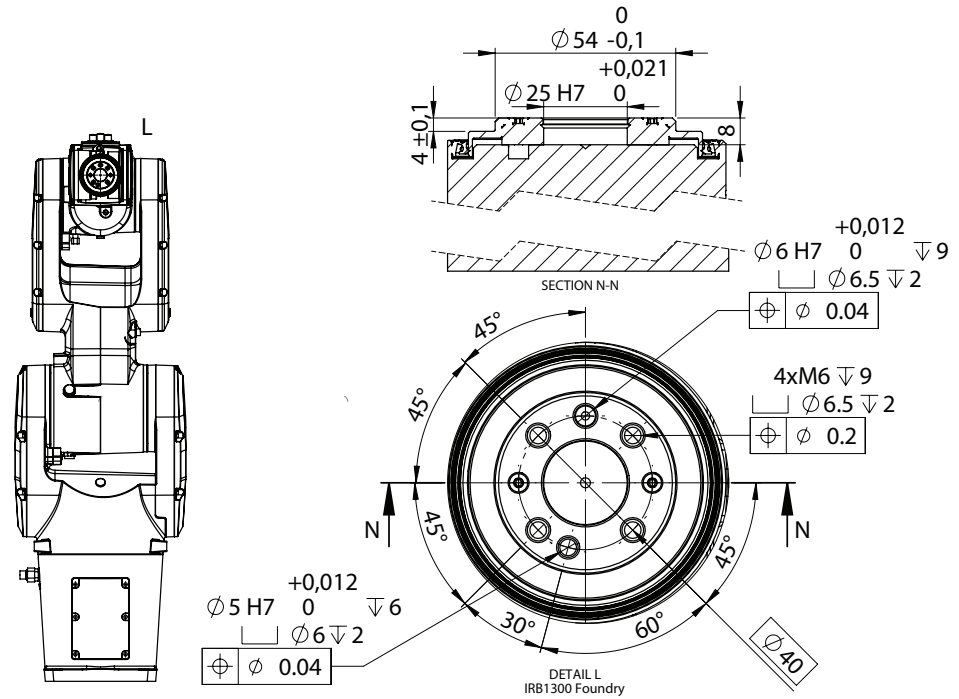

xx2100000705

Continues on next page

Fastener quality

When fitting tools on the tool flange, only use screws with quality 12.9. For other equipment use suitable screws and tightening torque for your application.

1 Description

1.7 Maintenance and troubleshooting

1.7 Maintenance and troubleshooting

General

The robot requires only minimum maintenance during operation. It has been designed to make it as easy to service as possible:

- Maintenance-free AC motors are used.
- Oil is used for the gearboxes.
- The cabling is routed for longevity, and in the unlikely event of a failure, its modular design makes it easy to change.

Maintenance

The maintenance intervals depend on the use of the robot. The required maintenance activities also depend on the selected options. For detailed information on maintenance procedures, see the maintenance section in *Product manual - IRB 1300*.

1.8 Robot motion

1.8.1 Adjusting the working range

Reasons for adjusting the manipulator working range

The working range of each manipulator axis is configured in the software. If there is a risk that the manipulator may collide with other objects at installation site, its working space should be limited. The manipulator must always be able to move freely within its entire working space.

Working range configurations

The parameter values for the axes working range can be altered within the allowed working range and according to available options for the robot, either to limit or to extend a default working range. Allowed working ranges and available options for each manipulator axis are specified in [Working range on page 27](#).

Mechanical stops on the manipulator

Mechanical stops are and can be installed on the manipulator as limiting devices to ensure that the manipulator axis does not exceed the working range values set in the software parameters.



Note

The mechanical stops are only installed as safety precaution to physically stop the robot from exceeding the working range set. A collision with a mechanical stop always requires actions for repair and troubleshooting.

Axis	Fixed mechanical stop ⁱ	Movable mechanical stop ⁱⁱ
Axis 1	yes	no
Axis 2	yes	no
Axis 3	yes	no
Axis 4	yes	no
Axis 5	yes	no
Axis 6	no	no

ⁱ Part of the casting or fixed on the casting and can not /should not be removed.

ⁱⁱ Can be installed in one or more than one position, to ensure a reduced working range, or be removed to allow extended working range.

1 Description

1.8.2 Mechanically restricting the working range

1.8.2 Mechanically restricting the working range

Location of mechanical stops

Axis 1

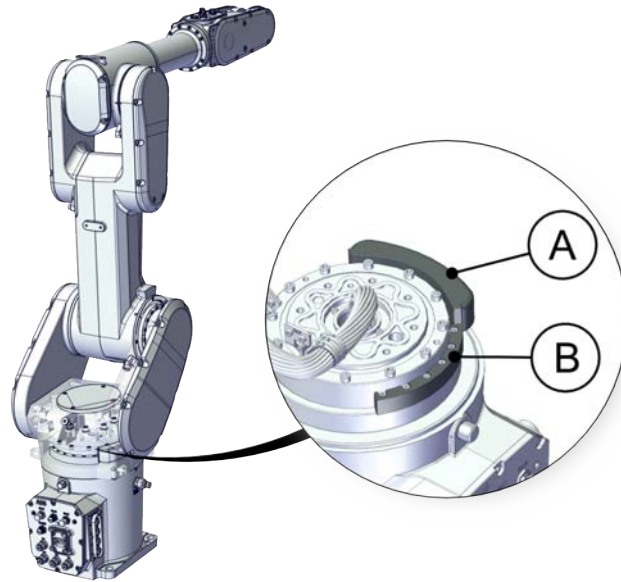

xx200000406

A	Mechanical stop, axis 1, slider
B	Mechanical stop, axis 1, fixed block

Axis 2

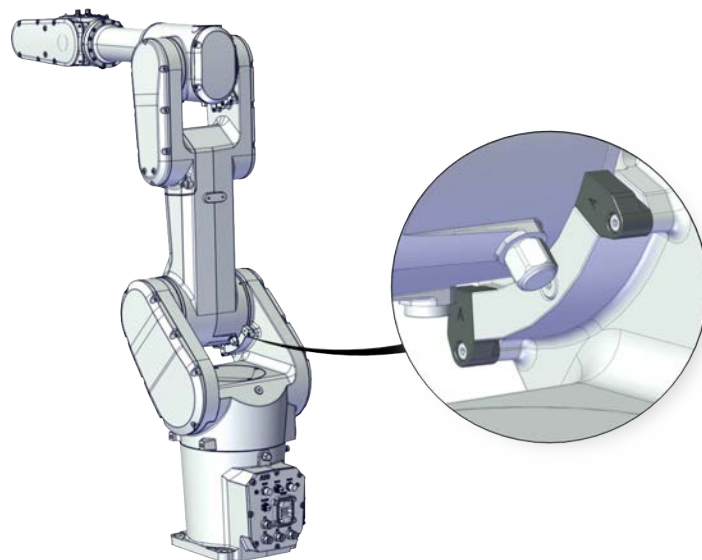

xx200000407

Continues on next page

Axis 3

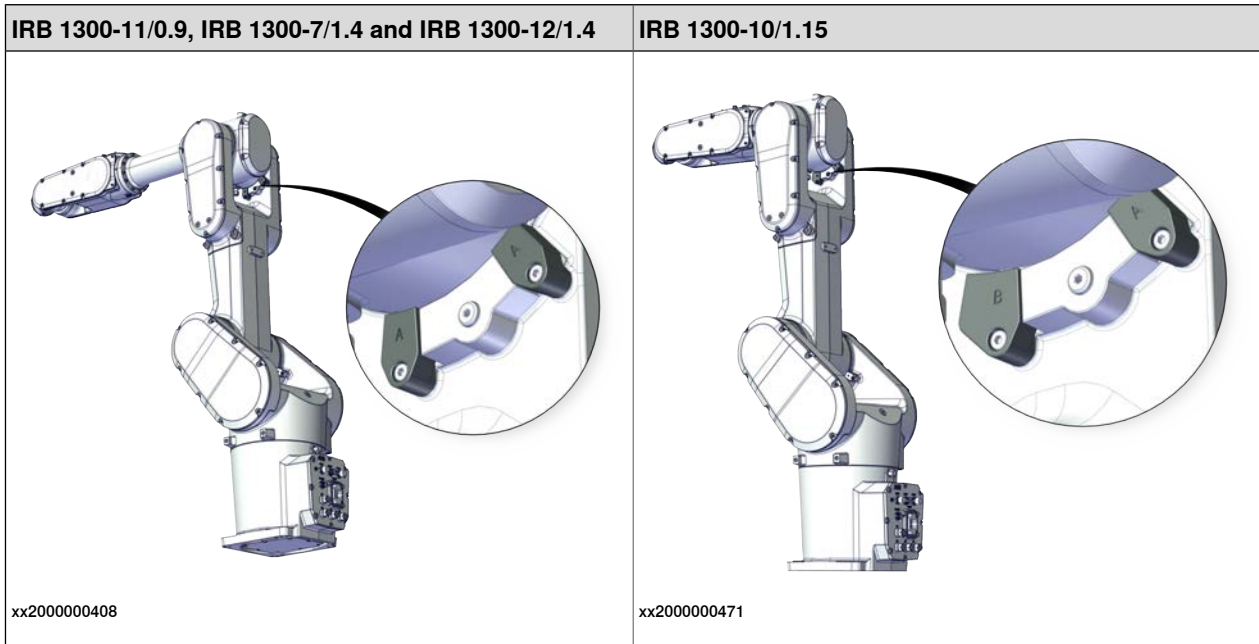

Axis 4

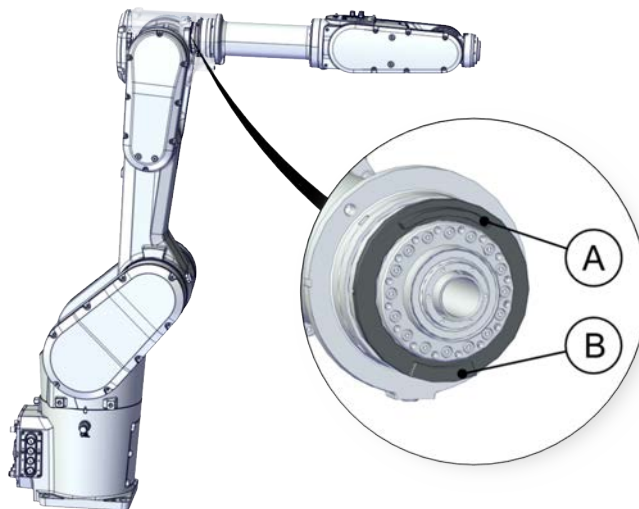

xx2000000409

A	Mechanical stop, axis 4, flange
B	Mechanical stop, axis 4, slider

Continues on next page

1 Description

1.8.2 Mechanically restricting the working range

Continued

Axis 5

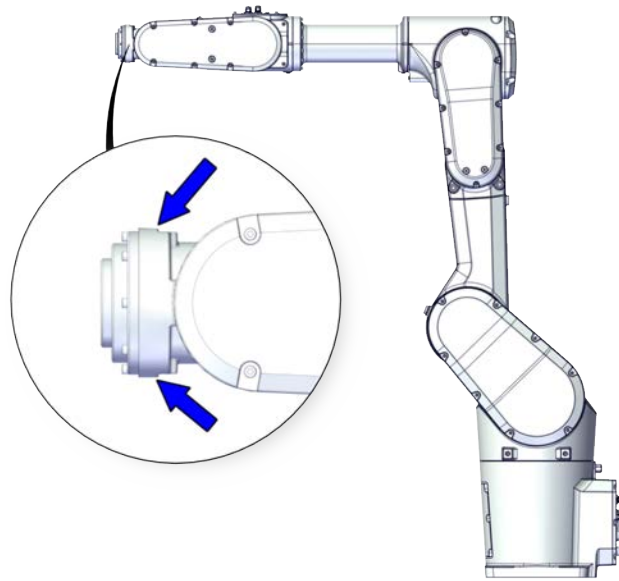

xx2000002181

1.8.3 Performance according to ISO 9283

General

At rated maximum load, maximum offset and 1.6 m/s velocity on the inclined ISO test plane, with all six axes in motion. Values in the table below are the average result of measurements on a small number of robots. The result may differ depending on where in the working range the robot is positioning, velocity, arm configuration, from which direction the position is approached, the load direction of the arm system. Backlashes in gearboxes also affect the result.

The figures for AP, RP, AT and RT are measured according to figure below.

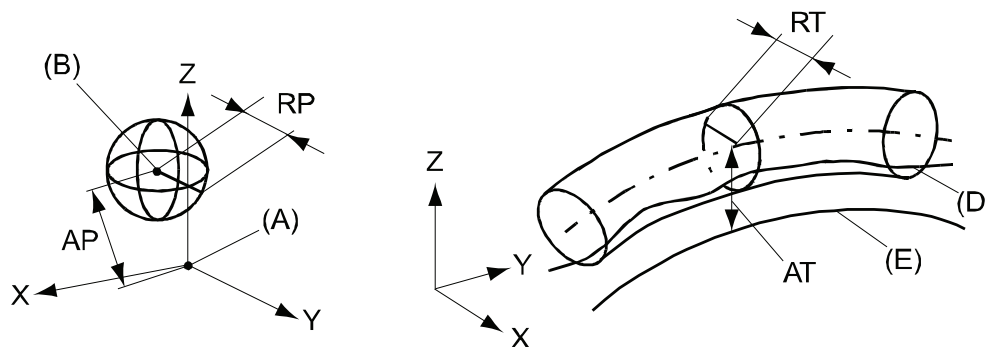

xx080000424

Pos	Description	Pos	Description
A	Programmed position	E	Programmed path
B	Mean position at program execution	D	Actual path at program execution
AP	Mean distance from programmed position	AT	Max deviation from E to average path
RP	Tolerance of position B at repeated positioning	RT	Tolerance of the path at repeated program execution

IRB 1300	11/0.9	10/1.15	7/1.4	12/1.4
Pose accuracy, AP ⁱ (mm)	0.02	0.025	0.02	0.03
Pose repeatability, RP (mm)	0.02	0.023	0.03	0.05
Pose stabilization time, PSt (s) within 0.1 mm of the position	0.28	0.27	0.38	0.56
Path accuracy, AT (mm)	1.01	0.98	1.49	1.52
Path repeatability, RT (mm)	0.08	0.04	0.07	0.04

ⁱ AP according to the ISO test above, is the difference between the taught position (position manually modified in the cell) and the average position obtained during program execution.

1 Description

1.8.4 Velocity

1.8.4 Velocity

Maximum axis speed (full performance)

with OmniCore C30/C90XT

Robot type	Axis 1	Axis 2	Axis 3	Axis 4	Axis 5	Axis 6
IRB 1300-11/0.9	243 °/s	225 °/s	330 °/s	500 °/s	415 °/s	720 °/s
IRB 1300-10/1.15	238 °/s	228 °/s	336 °/s	500 °/s	415 °/s	720 °/s
IRB 1300-7/1.4	249 °/s	180 °/s	247 °/s	500 °/s	415 °/s	720 °/s
IRB 1300-12/1.4	230 °/s	116 °/s	138 °/s	500 °/s	415 °/s	687 °/s

with OmniCore E10

Robot type	Axis 1	Axis 2	Axis 3	Axis 4	Axis 5	Axis 6
IRB 1300-11/0.9	280 °/s	228 °/s	330 °/s	500 °/s	415 °/s	720 °/s
IRB 1300-10/1.15	280 °/s	228 °/s	336 °/s	500 °/s	415 °/s	720 °/s
IRB 1300-7/1.4	255 °/s	180 °/s	247 °/s	500 °/s	415 °/s	720 °/s
IRB 1300-12/1.4	230 °/s	116 °/s	138 °/s	500 °/s	415 °/s	687 °/s

There is a supervision function to prevent overheating in applications with intensive and frequent movements (high duty cycle).

1.9 Robot stopping distances and times

1.9.1 Robot stopping distances according to ISO 10218-1

About the data for robot stopping distances and times

All measurements and calculations of stopping distances and times are done according to ISO 10218-1, with single axis motion on axes 1, 2, and 3. If more than one axis is used for the movement, then the stopping distance and time can be longer. Normal delays of the hardware and software are taken into account. See more about the delays and their impact on the results, [Reading the data on page 69](#).

The stopping distances and times are presented using the tool data and extension zones presented for the respected robot variant. These variables are 100%, 66%, and 33% of the maximum values for the robot.

The stop categories 0 and 1 are according to IEC 60204-1.



Note

The category 0 stop is not necessarily the worst case (depending on load, speed, application, wear, etc.).



Note

The stop category 1 is a controlled stop and will therefore have less deviation from the programmed path compared with a stop category 0.

Loads

The tool data that is used is presented for the respective robot variant.

The used loads represent the rated load. No arm load is used. See the [Load diagrams on page 42](#).

Continues on next page

1 Description

1.9.1 Robot stopping distances according to ISO 10218-1

Continued

Extension zones

The extension zone for the stop category 1 is based on the tool mounting interface (tool flange) with the axis angles according to the following illustrations. The zone data is presented for the respective robot variant.

The extension zone outer limits are defined by the TCP0 position for the stated angles.

	Illustration
Axis 1	<p>xx2300000860</p>
Axis 2	<p>xx2300000861</p>

Continues on next page

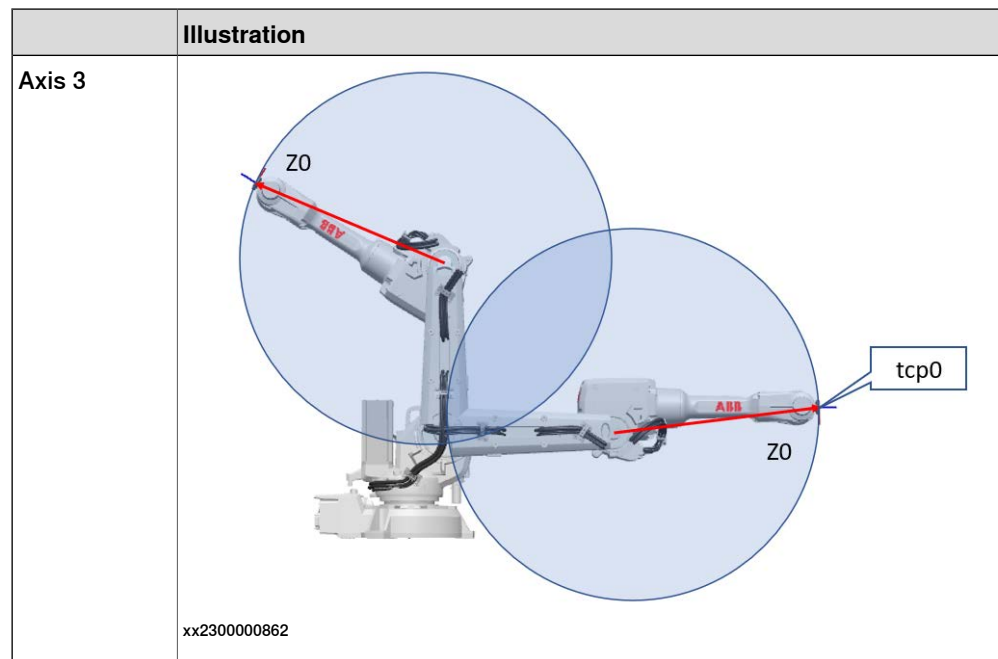

Speed

The speed in the simulations is based on TCP0.

The TCP0 speed is measured in meters per second when the stop is triggered.

Stopping distances

The stopping distance is measured in degrees.

Stopping times

The stopping time is measured in seconds.

Limitations

The stopping distance can vary depending on additional loads on the robot.

The stopping distance for category 0 stops can vary depending on the individual brakes and the joint friction.

Reading the data

The data for stop category 0 is presented in tables, with distance and time for each axis.

The data for stop category 1 is presented as graphs with curves representing the different loads.

There is a short delay in the stop, which means that if the axis is accelerating when the stop is initiated (C), it will continue to accelerate during this delay time. This

Continues on next page

1 Description

1.9.1 Robot stopping distances according to ISO 10218-1

Continued

can result in graphs where a higher load (A) gives shorter stopping distance than a smaller load (B).

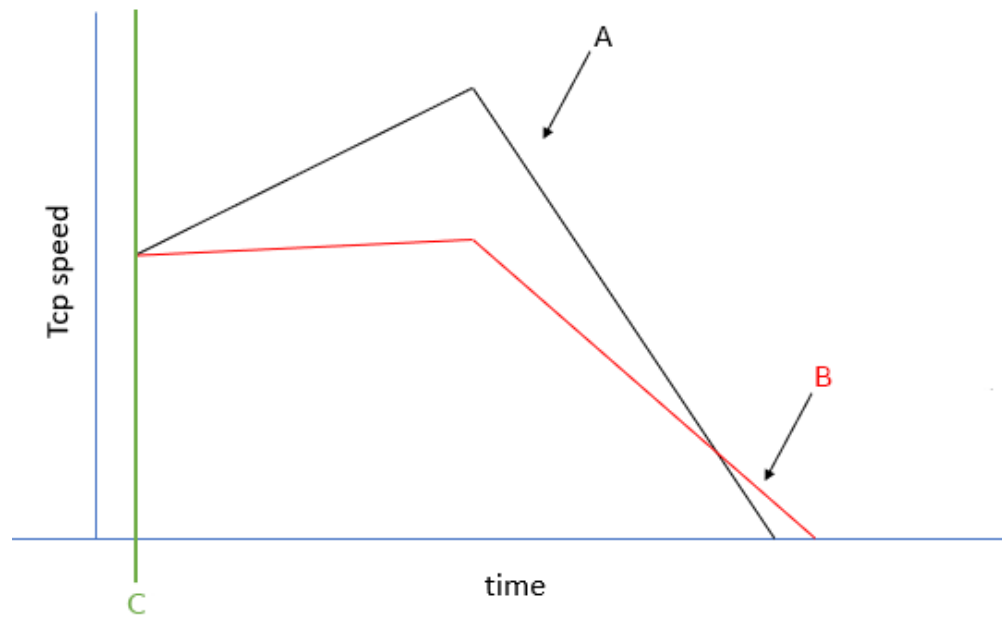

xx2300001041

The tcp speed is the actual speed when the stop is initiated, which is not necessarily the programmed speed.

1.9.2 Measuring stopping distance and time

Preparations before measuring

For measurement and calculation of overall system stopping performance, see ISO 13855:2010.

The measurement shall be done for the selected stop category. The emergency stop button on the robot controller is configured for stop category 0 on delivery. A risk assessment can conclude the need for another stop category. The stop category can be changed through the system parameter *Function* (topic *Controller*, type *Safety Run Chain*). In case of deviations of the default configuration of stop category 0, then this is detailed in the product specification for the respective manipulator.



CAUTION

The measurement and calculation of overall stopping performance for a robot must be tested with its correct load, speed, and tools, in its actual environment, before the robot is taken into production.

All load and tool data must be correctly defined (weight, CoG, moment of inertia). The load identification service routine can be used to identify the data.



CAUTION

Follow the safety instructions in the respective product manual for the robot.

Measuring with TuneMaster

The software TuneMaster can be used to measure stopping distances and times for ABB robots. The TuneMaster software contains documentation on how to use it.

- 1 Download TuneMaster from www.abb.com/robotics, section **RobotStudio - Downloads - RobotWare Tools and Utilities**.
- 2 Install TuneMaster on a computer. Start the TuneMaster app and select **Log Signals**.
- 3 Connect to the robot controller.
- 4 Define the I/O stop signal to use for measurement, for example, ES1 for emergency stop.
- 5 Define the signal number to use for measurement, 1298 for axis position. The value is given in radians.
- 6 Start the logging in TuneMaster.
- 7 Start the test program on the controller.



Tip

Use the tool and zone definitions for the respective variant in this document to get results that are comparable with this document.

Continues on next page

1 Description

1.9.2 Measuring stopping distance and time

Continued

- 8 When the axis has reached maximum speed, press the emergency stop button.
- 9 In TuneMaster, measure the stopping distance and time.
- 10 Repeat for all installed emergency stop buttons until the identified hazards due to stopping distance and time for axes have been verified.

Example from TuneMaster

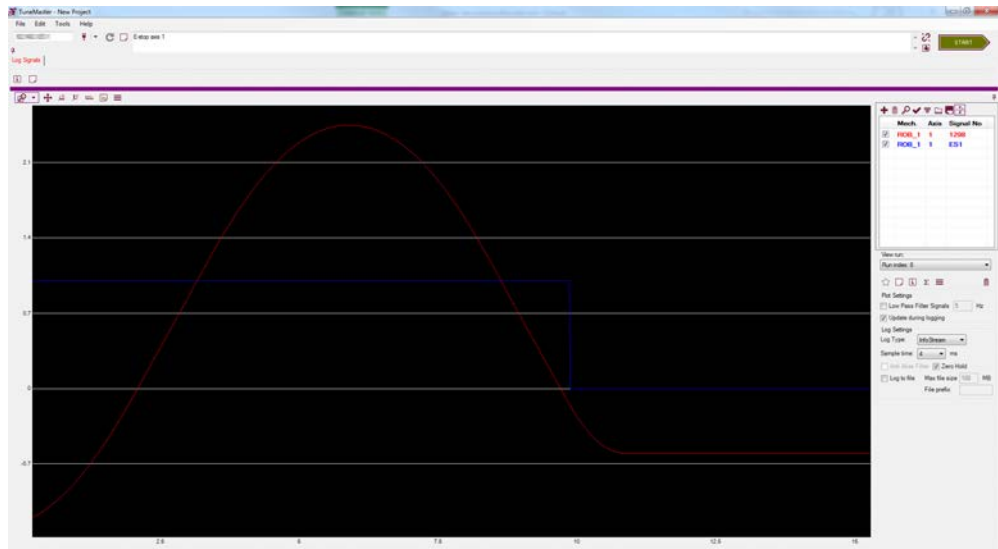

xx160000386

1.9.3 IRB 1300 0.9 m 11 kg

Category 0

The following table describes the stopping distance and time for category 0 emergency stop at max speed, with the arm stretched out to the maximum with maximum load. All results are from tests on one moving axis.

Axis	Distance (degrees)	Stop time (s)
1	39.26	0.27
2	35.23	0.31
3	52.07	0.30

Category 1, extension zones

For definitions of the zones, see [Extension zones on page 68](#).

Zone	wcp min (m)	wcp max (m)
0	0	0.301
1	0.301	0.601
2	0.601	max reach

Category 1, Axis A1

Extension zone 0, stopping distance and stopping time

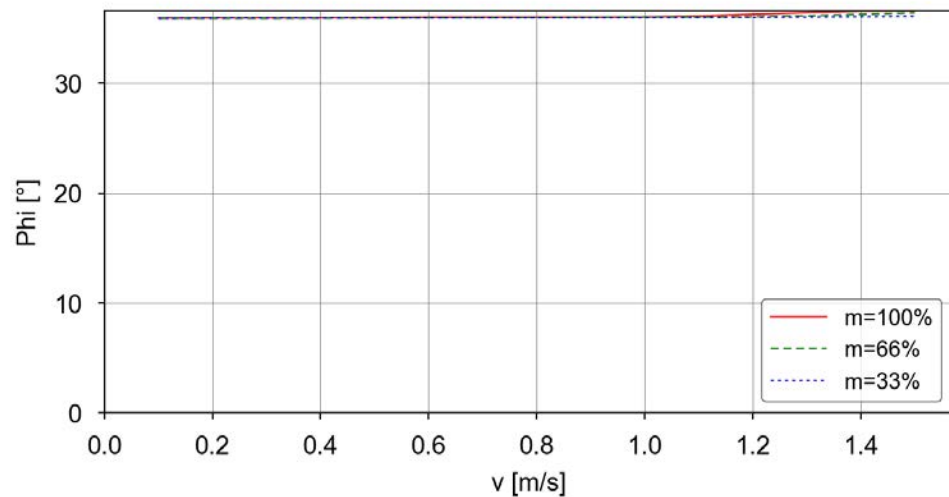

Continues on next page

1 Description

1.9.3 IRB 1300 0.9 m 11 kg

Continued

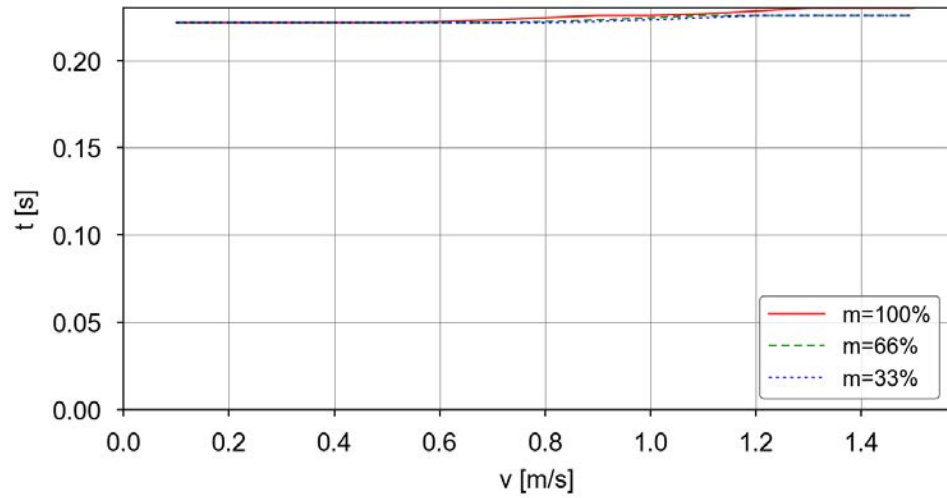

Extension zone 1, stopping distance and stopping time

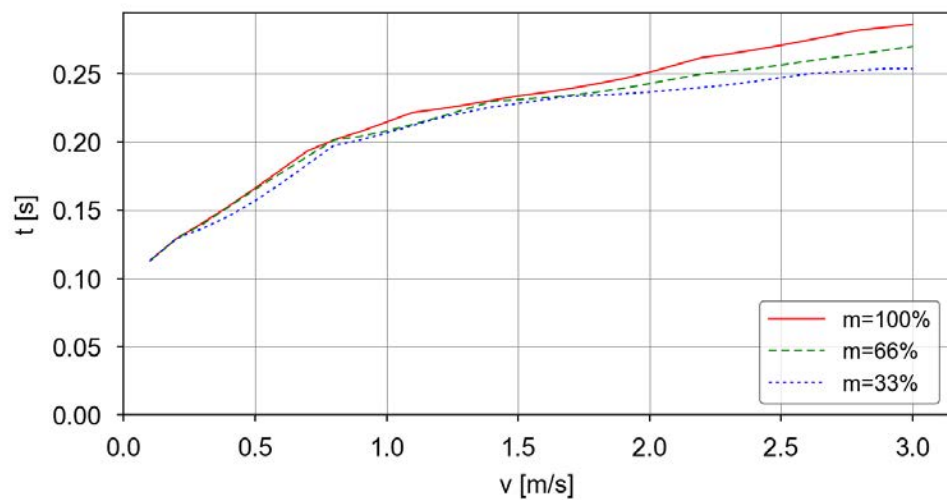
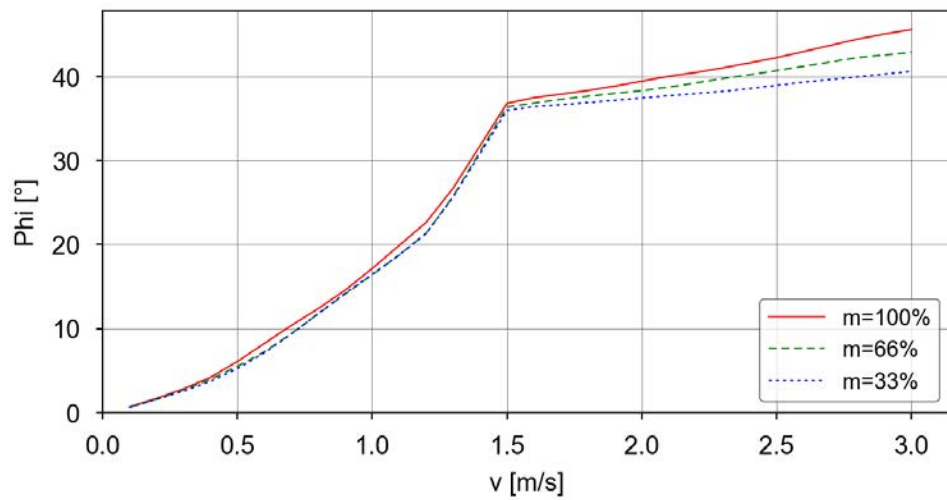

Continues on next page

Extension zone 2, stopping distance and stopping time

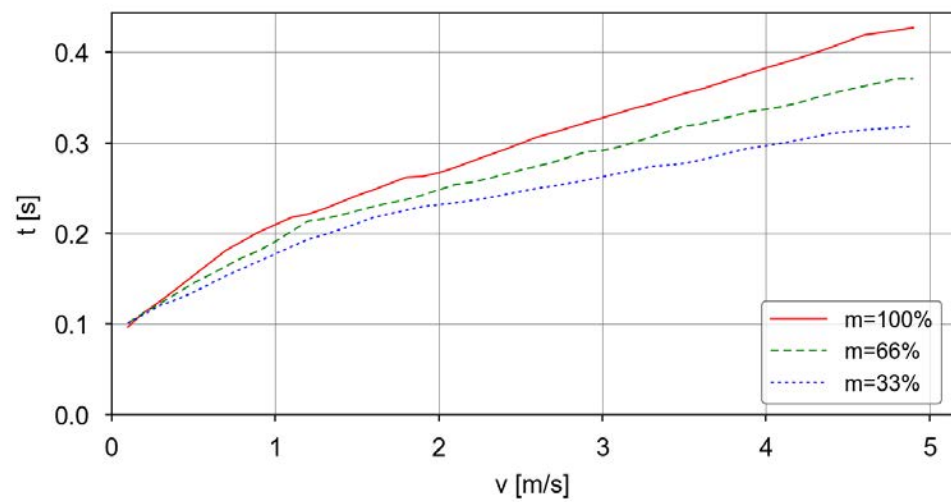
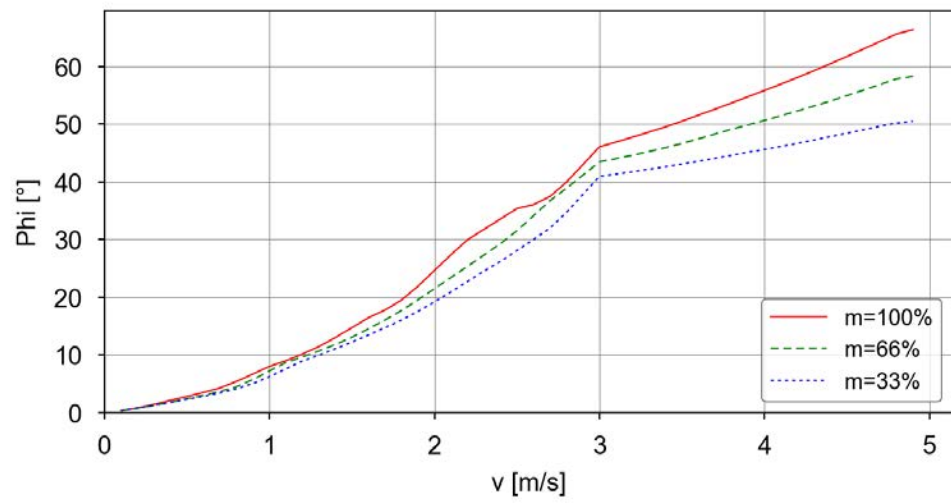

Continues on next page

1 Description

1.9.3 IRB 1300 0.9 m 11 kg

Continued

Category 1, Axis A2

Extension zone 0, stopping distance and stopping time

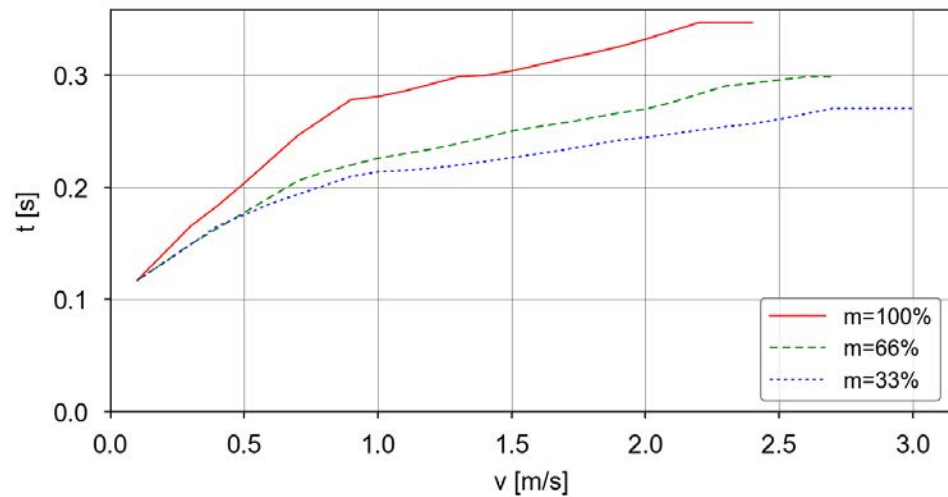
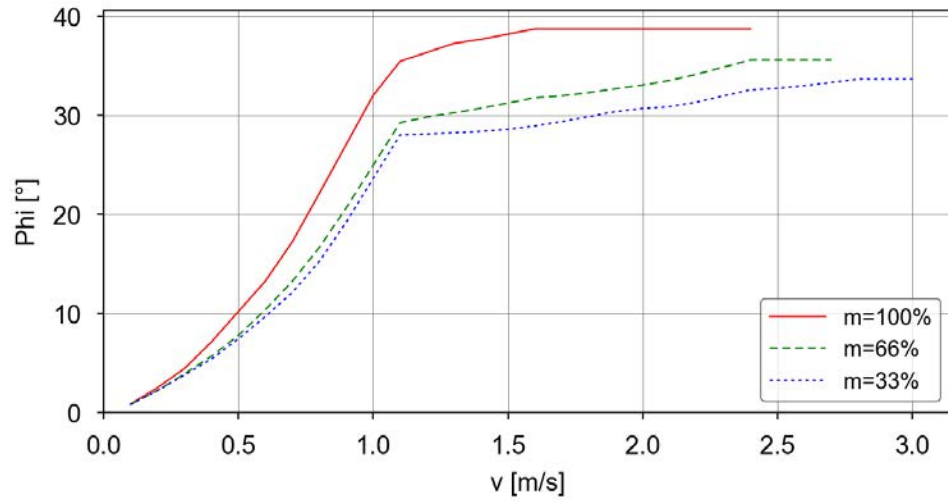

Continues on next page

Extension zone 1, stopping distance and stopping time

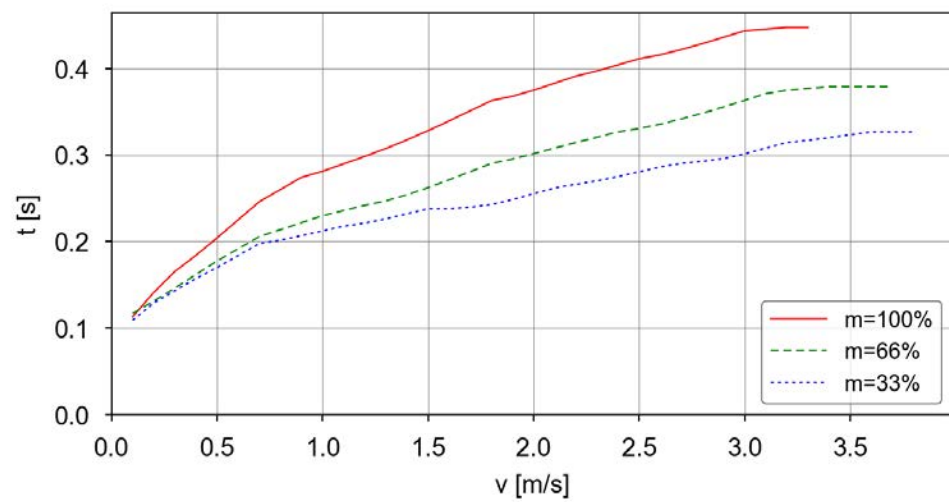
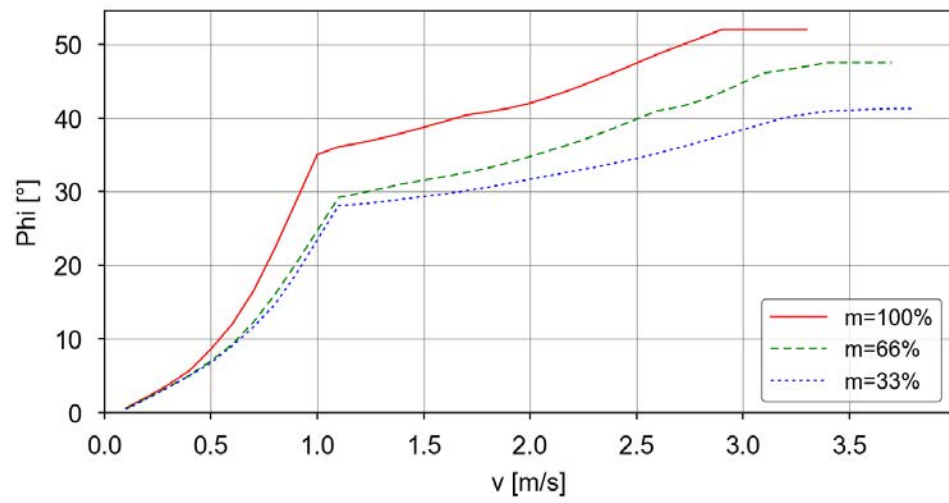

Continues on next page

1 Description

1.9.3 IRB 1300 0.9 m 11 kg

Continued

Extension zone 2, stopping distance and stopping time

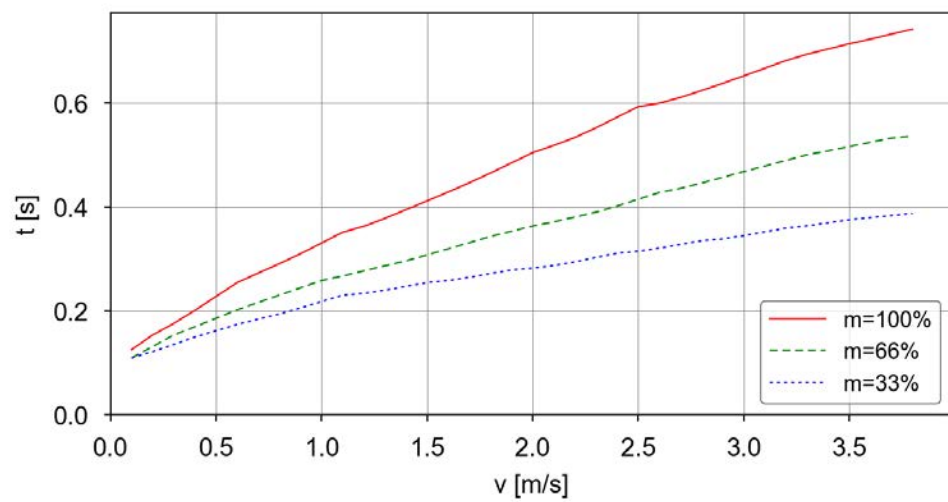
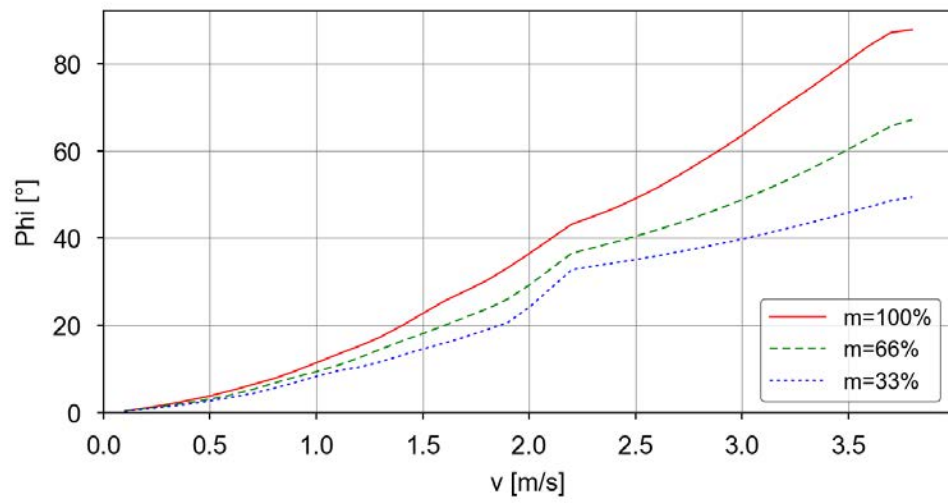

Continues on next page

Category 1, Axis A3

Extension zone 0, stopping distance and stopping time

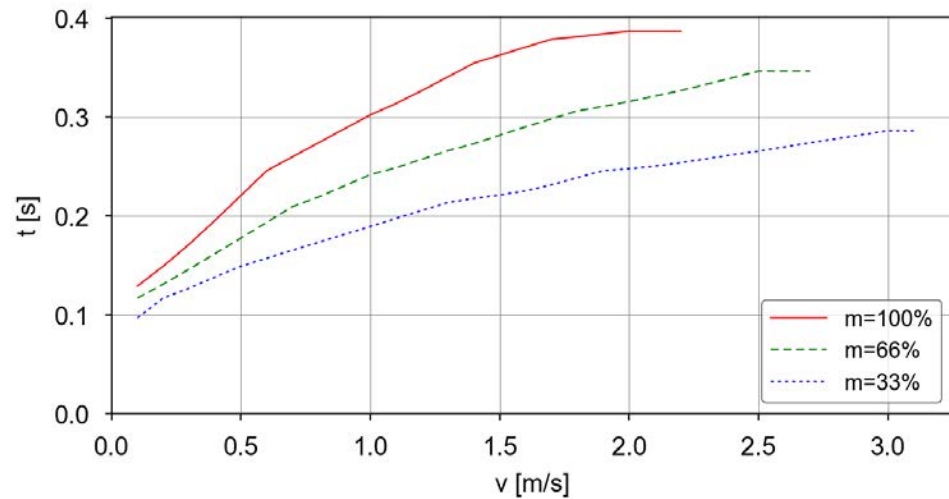
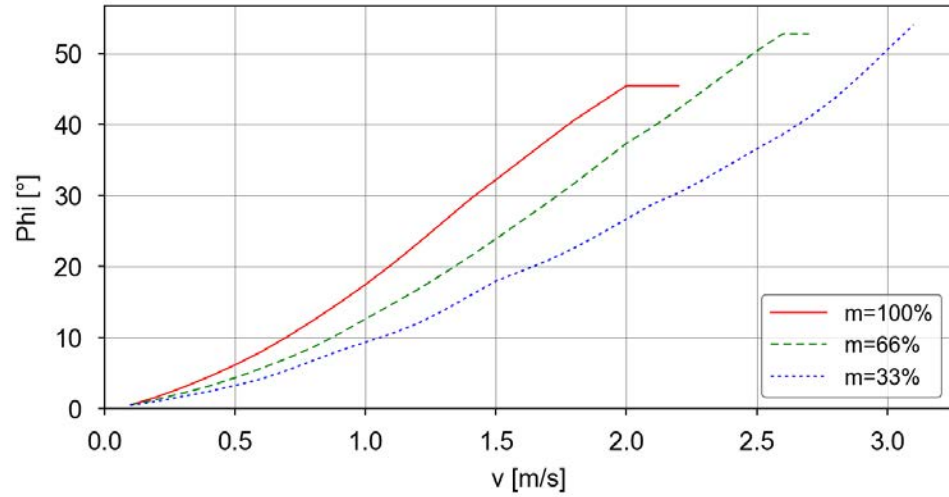

Continues on next page

1 Description

1.9.3 IRB 1300 0.9 m 11 kg

Continued

Extension zone 1, stopping distance and stopping time

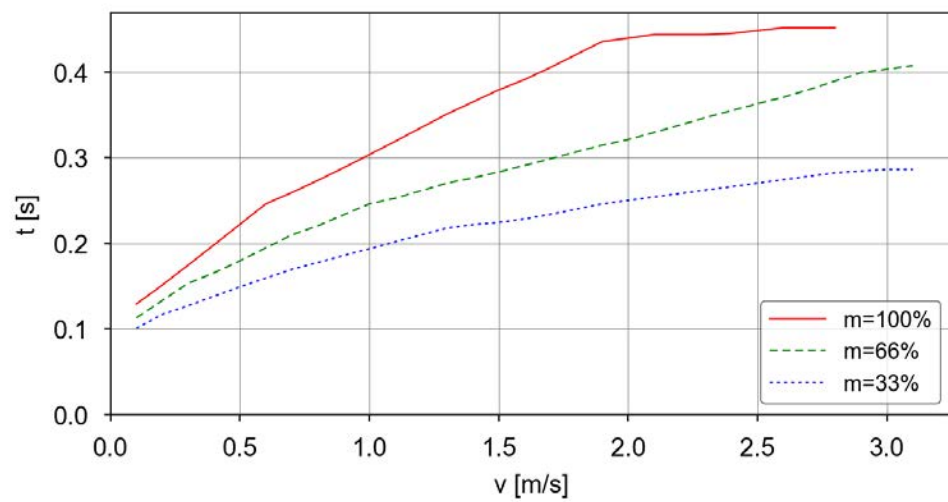
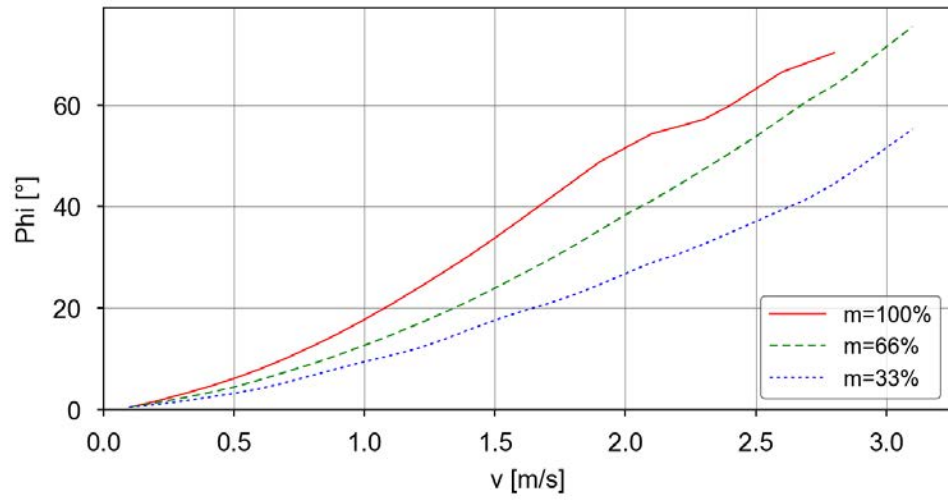

Continues on next page

Extension zone 2, stopping distance and stopping time

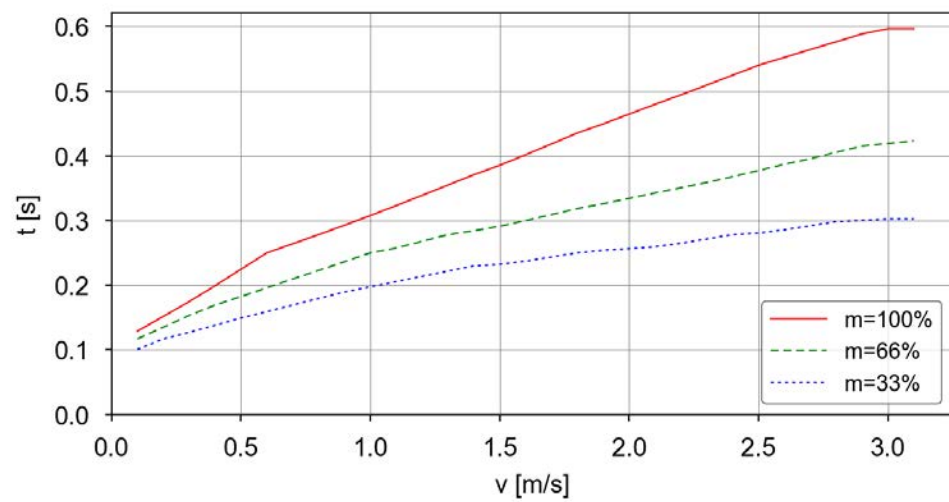
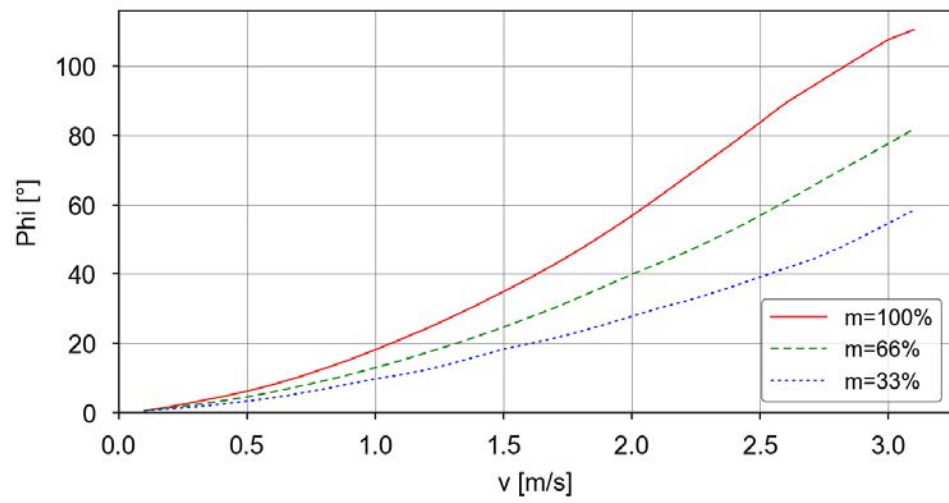

1 Description

1.9.4 IRB 1300 1.15 m 10 kg

1.9.4 IRB 1300 1.15 m 10 kg

Category 0

The following table describes the stopping distance and time for category 0 emergency stop at max speed, with the arm stretched out to the maximum with maximum load. All results are from tests on one moving axis.

Axis	Distance (degrees)	Stop time (s)
1	53.95	0.37
2	30.42	0.27
3	47.77	0.28

Category 1, extension zones

For definitions of the zones, see [Extension zones on page 68](#).

Zone	wcp min (m)	wcp max (m)
0	0	0.384
1	0.384	0.768
2	0.768	max reach

Category 1, Axis A1

Extension zone 0, stopping distance and stopping time

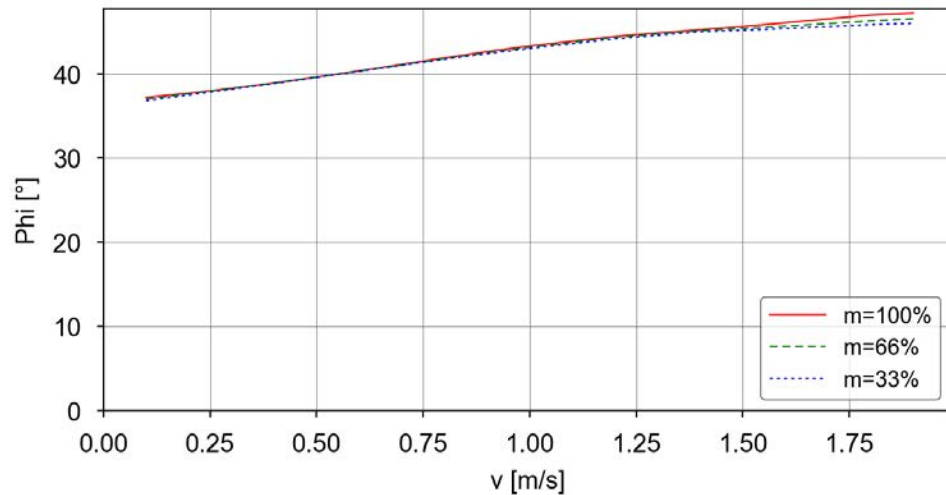

Continues on next page

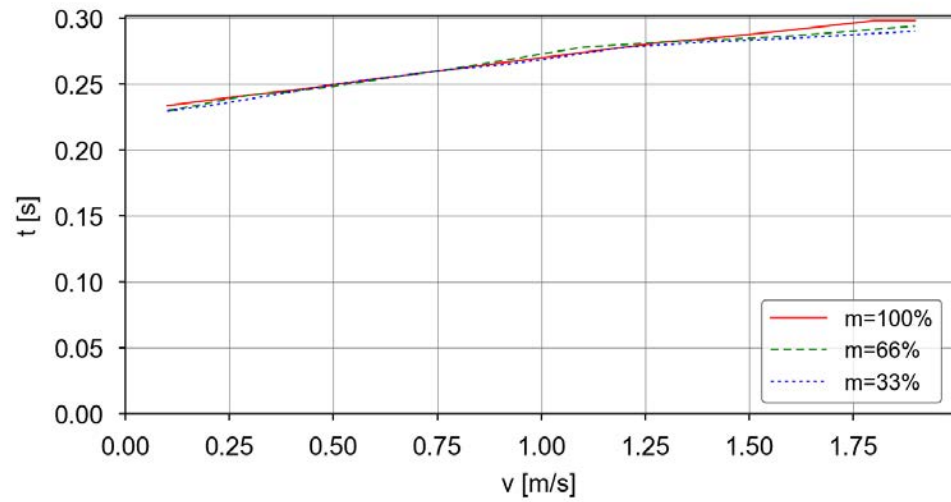

Extension zone 1, stopping distance and stopping time

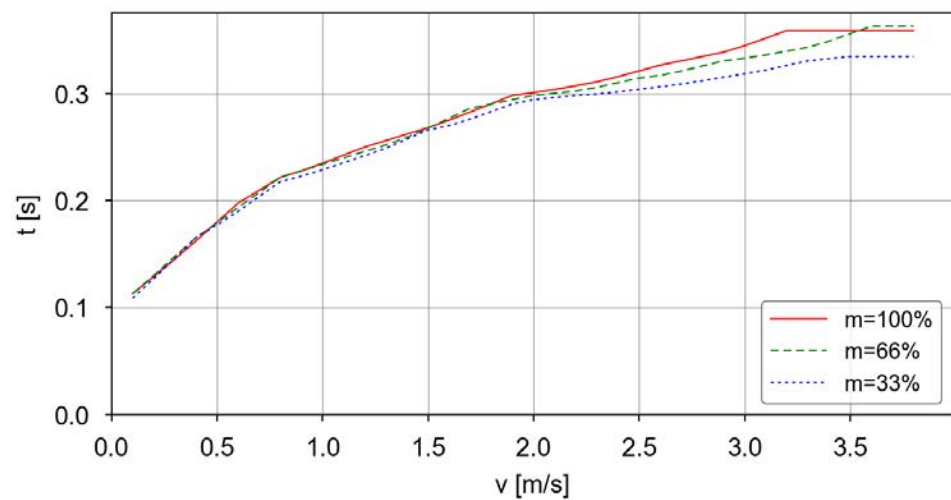
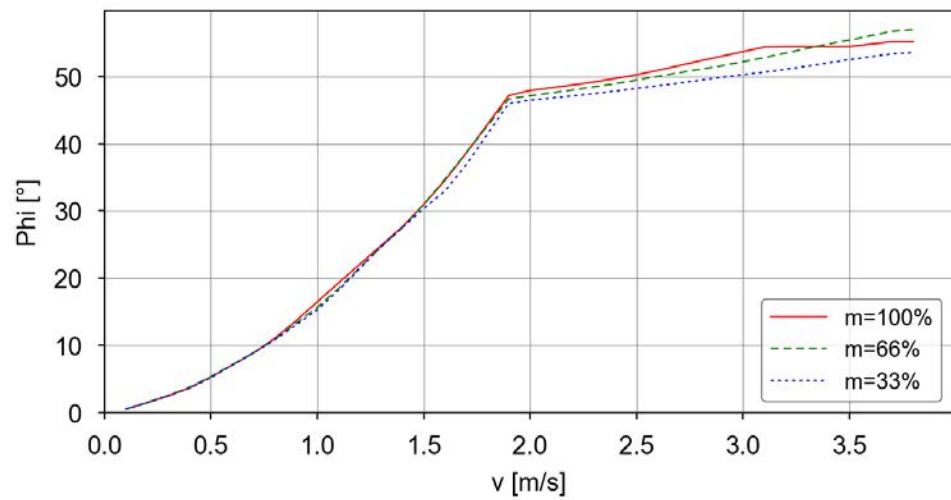

Continues on next page

1 Description

1.9.4 IRB 1300 1.15 m 10 kg

Continued

Extension zone 2, stopping distance and stopping time

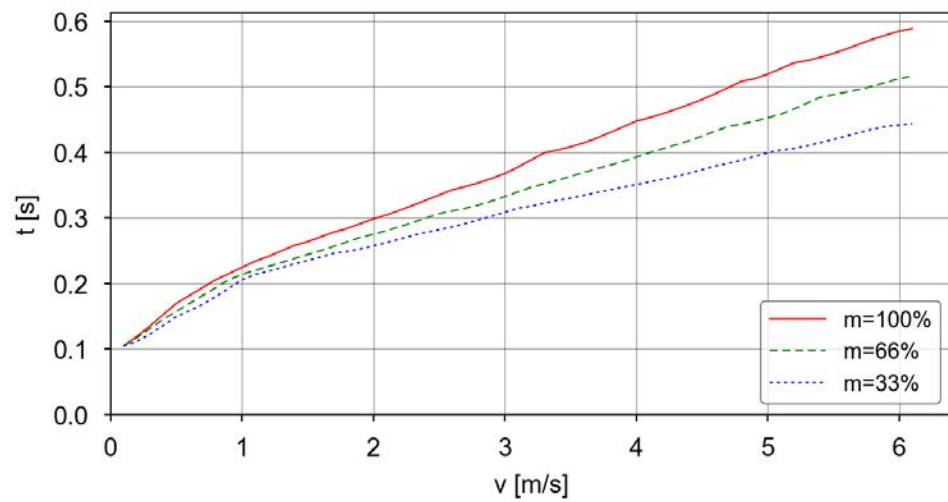
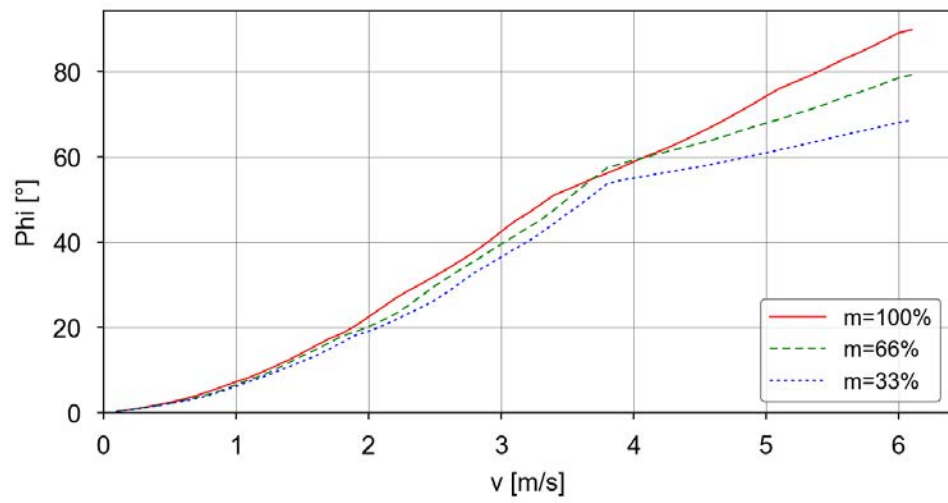

Continues on next page

Category 1, Axis A2

Extension zone 0, stopping distance and stopping time

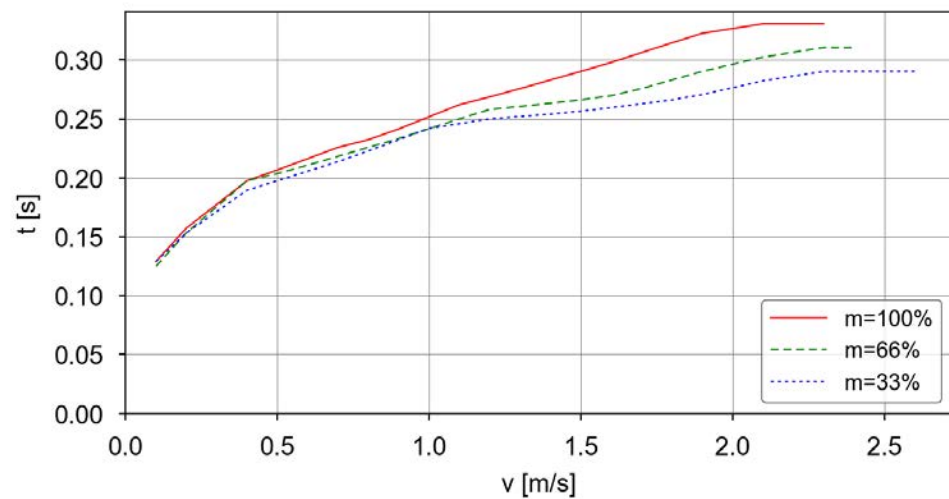
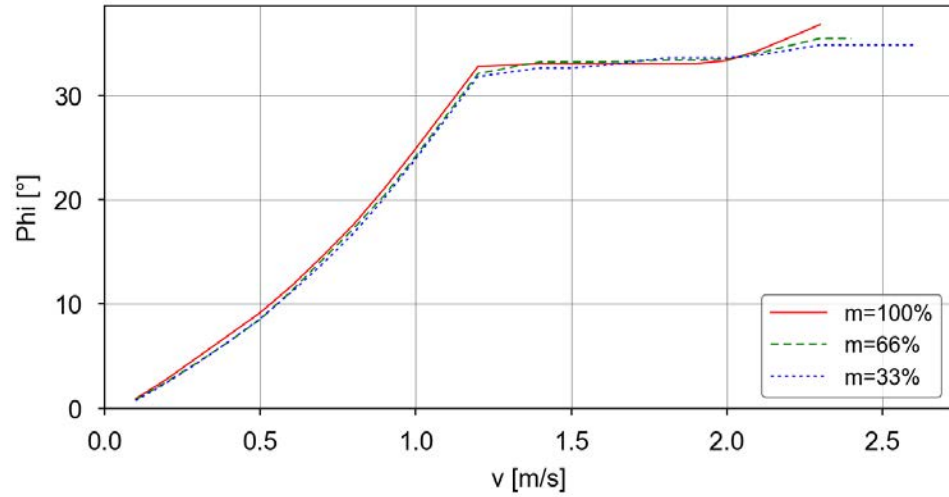

Continues on next page

1 Description

1.9.4 IRB 1300 1.15 m 10 kg

Continued

Extension zone 1, stopping distance and stopping time

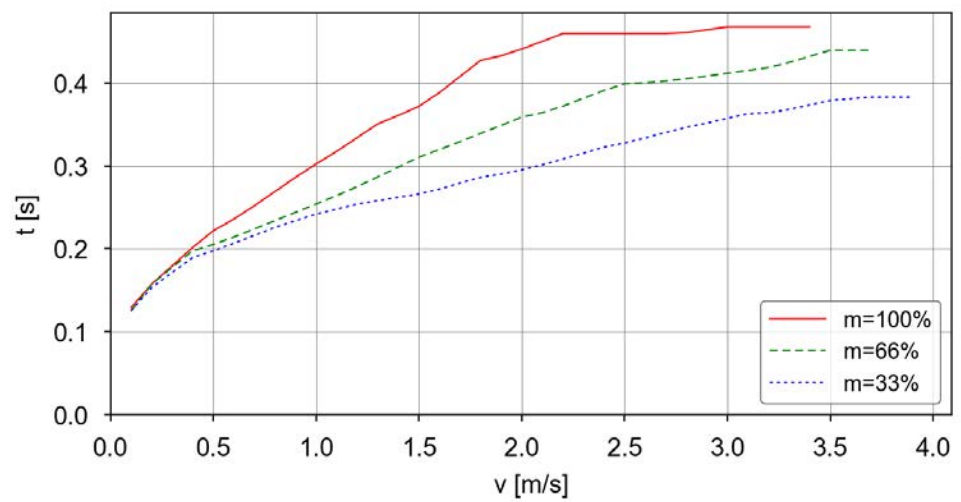
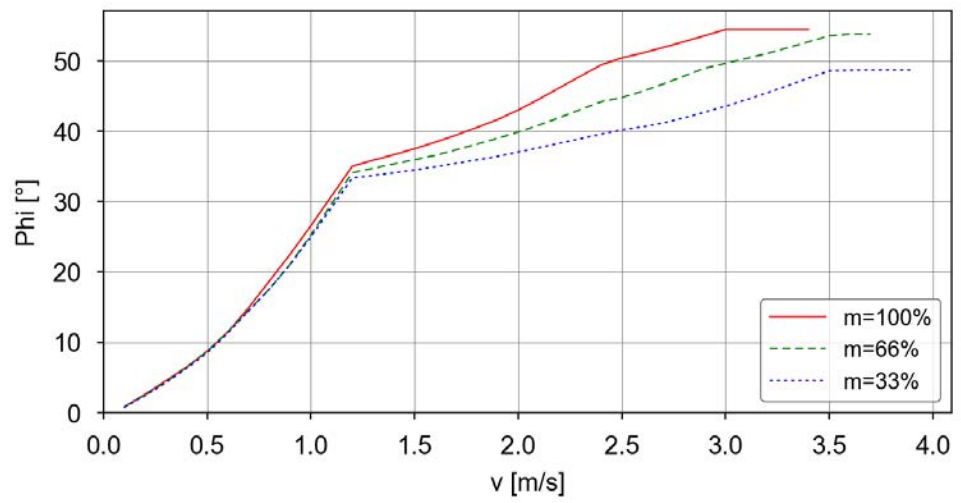

Continues on next page

Extension zone 2, stopping distance and stopping time

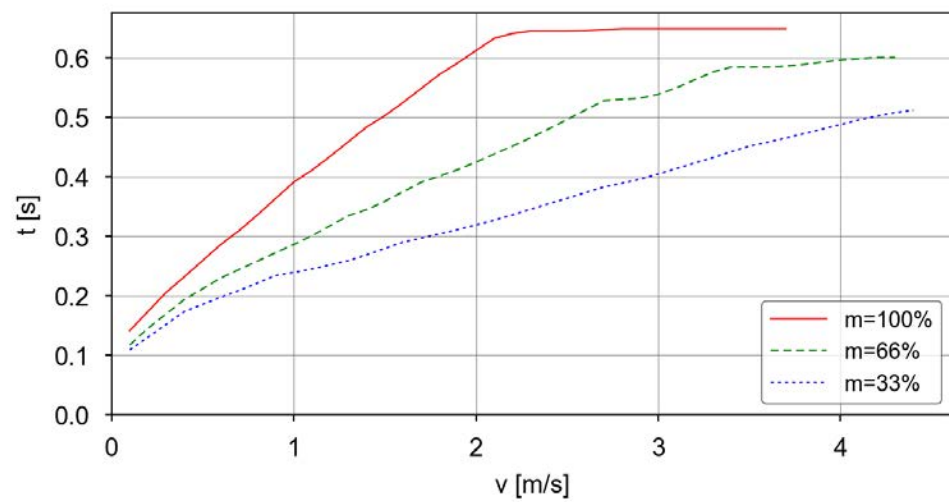
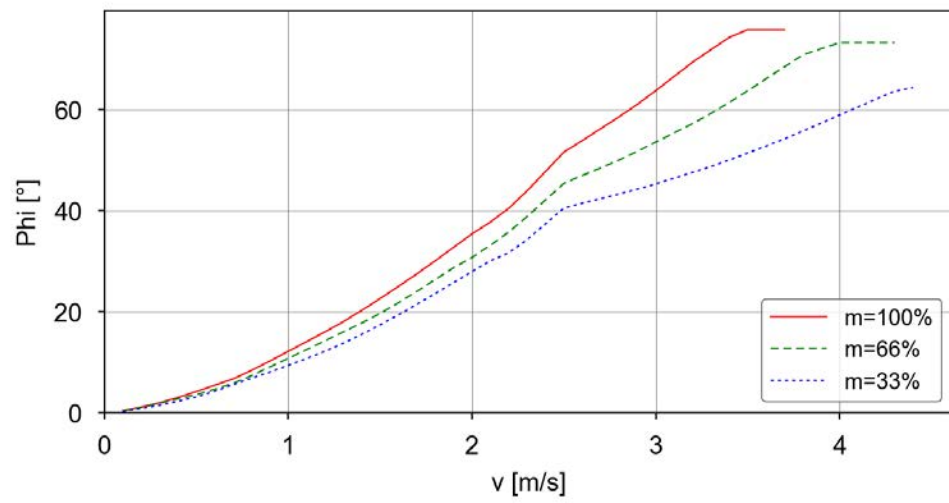

Continues on next page

1 Description

1.9.4 IRB 1300 1.15 m 10 kg

Continued

Category 1, Axis A3

Extension zone 0, stopping distance and stopping time

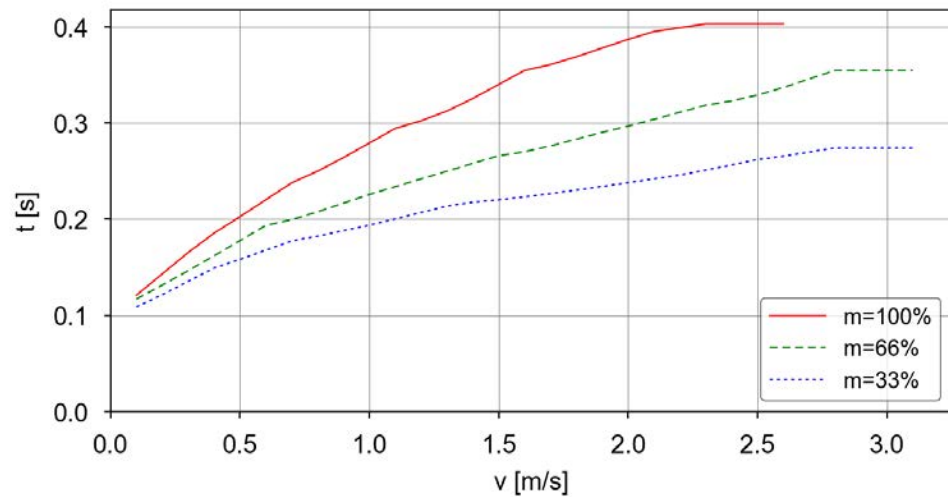
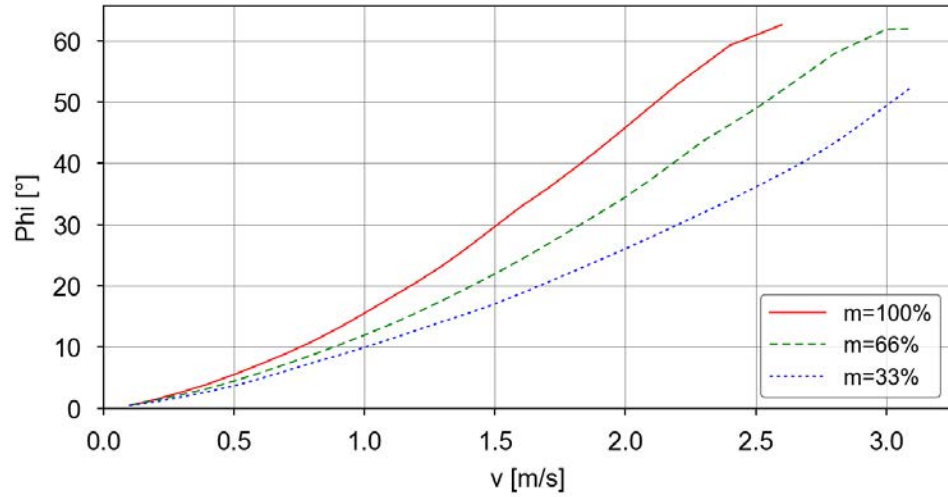

Continues on next page

Extension zone 1, stopping distance and stopping time

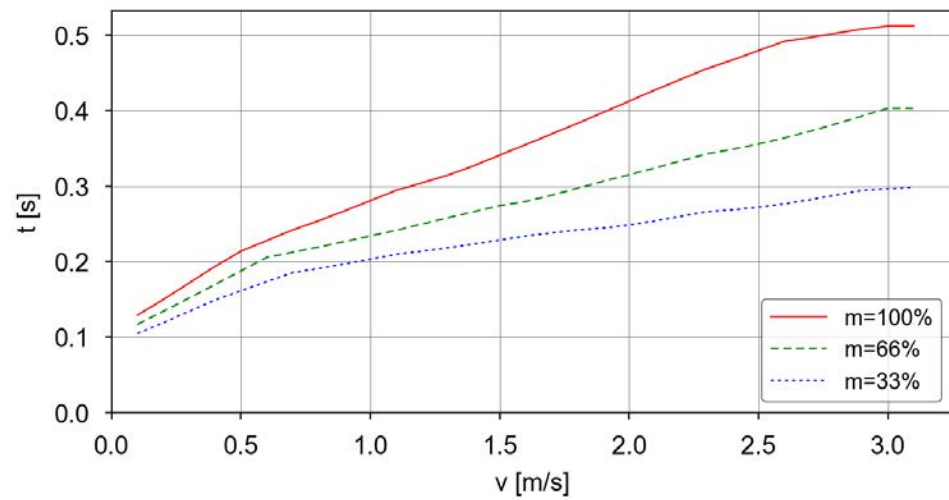
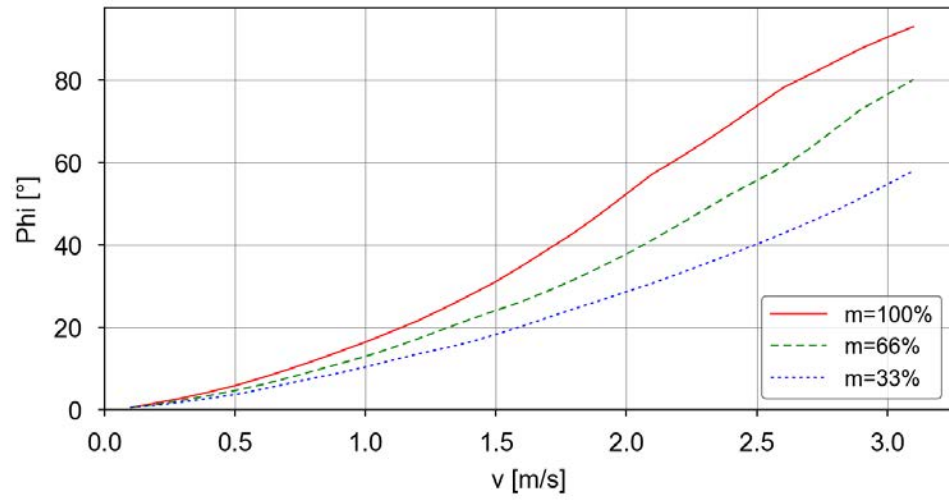

Continues on next page

1 Description

1.9.4 IRB 1300 1.15 m 10 kg

Continued

Extension zone 2, stopping distance and stopping time

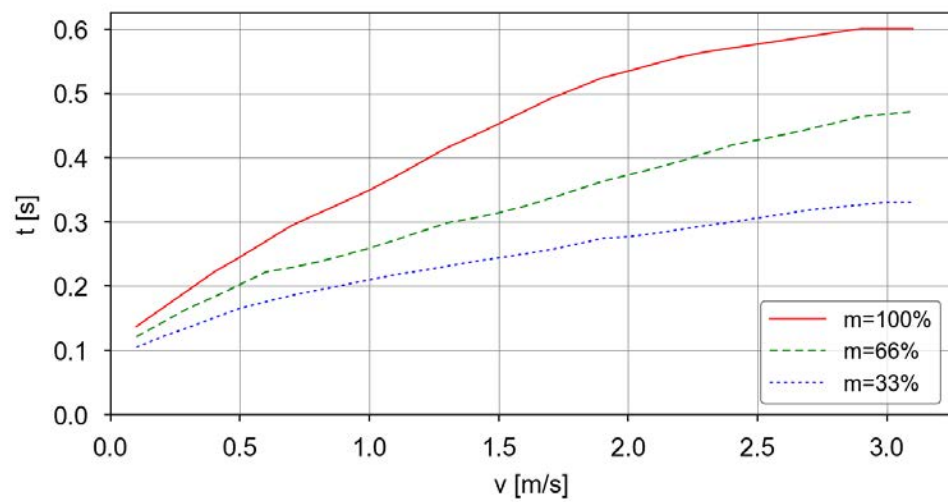
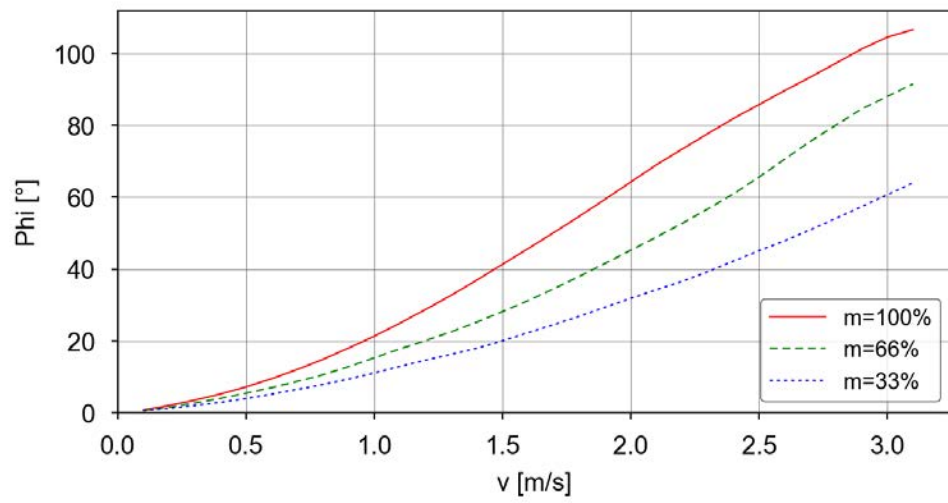

1.9.5 IRB 1300 1.4 m 7 kg

Category 0

The following table describes the stopping distance and time for category 0 emergency stop at max speed, with the arm stretched out to the maximum with maximum load. All results are from tests on one moving axis.

Axis	Distance (degrees)	Stop time (s)
1	55.25	0.40
2	33.39	0.37
3	35.66	0.27

Category 1, extension zones

For definitions of the zones, see [Extension zones on page 68](#).

Zone	wcp min (m)	wcp max (m)
0	0	0.467
1	0.467	0.934
2	0.934	max reach

Category 1, Axis A1

Extension zone 0, stopping distance and stopping time

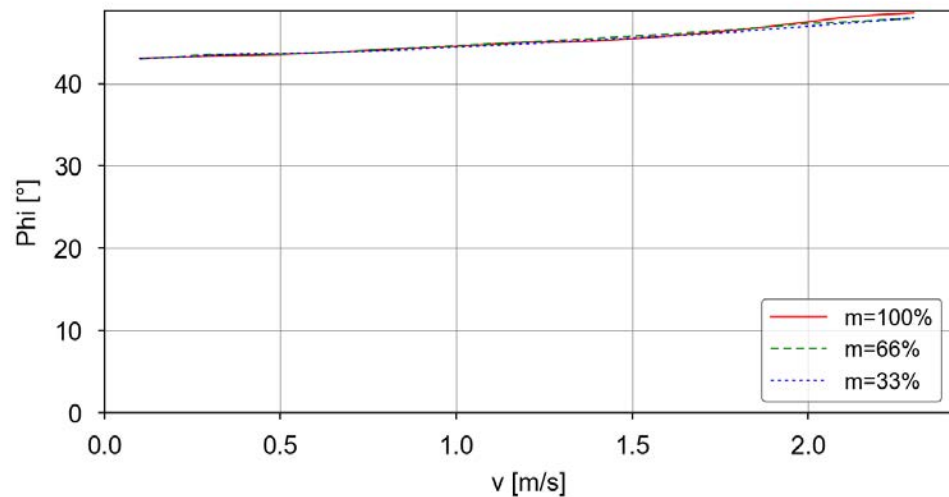

Continues on next page

1 Description

1.9.5 IRB 1300 1.4 m 7 kg

Continued

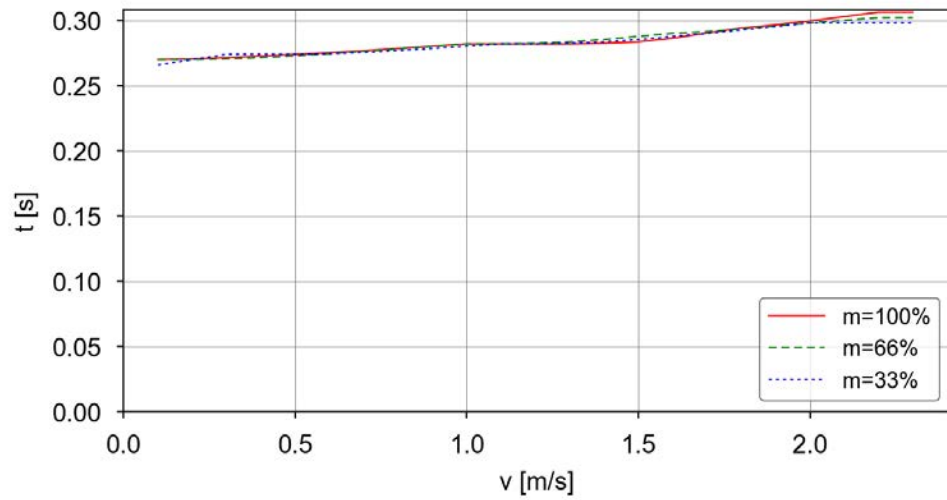

Extension zone 1, stopping distance and stopping time

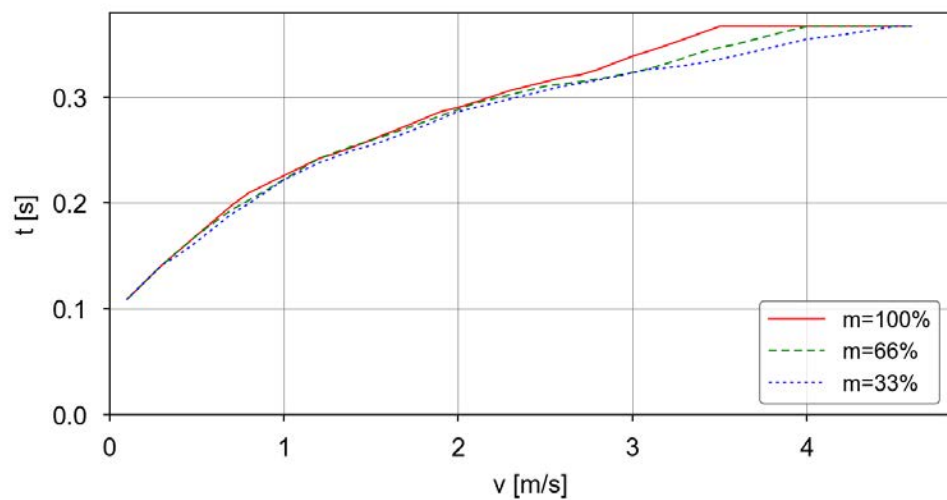
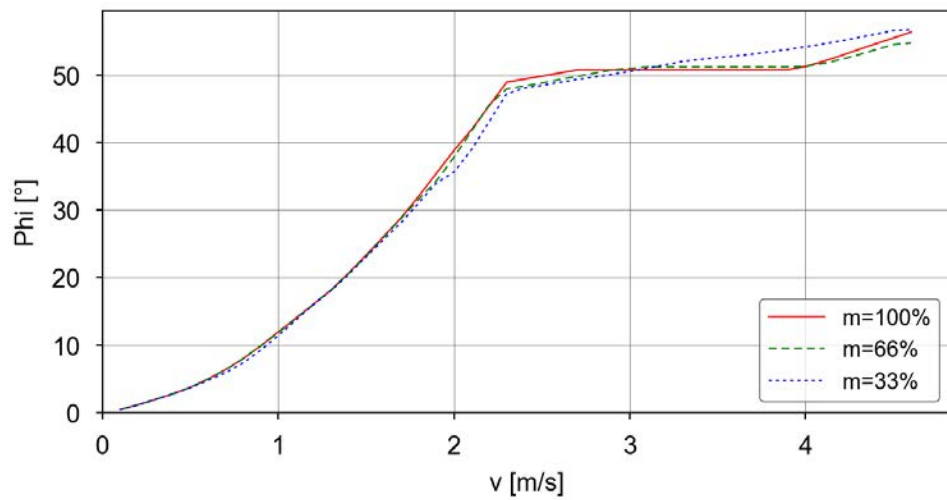

Continues on next page

Extension zone 2, stopping distance and stopping time

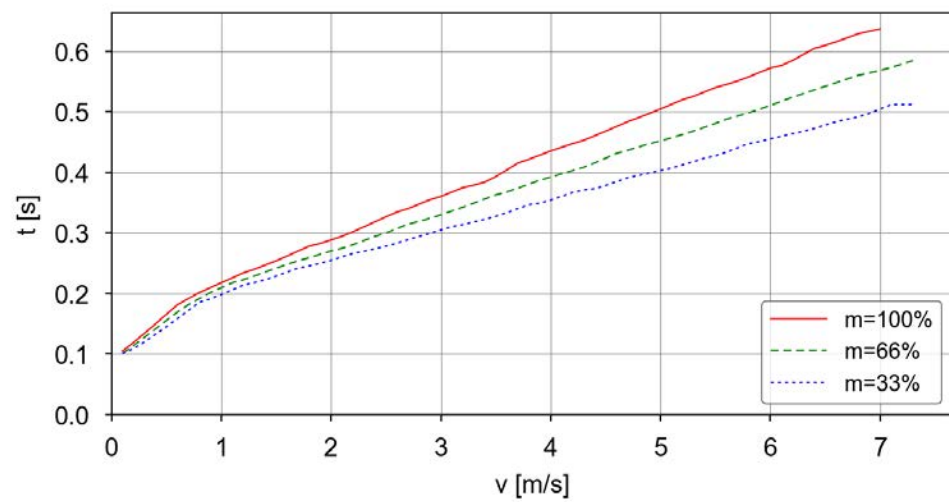
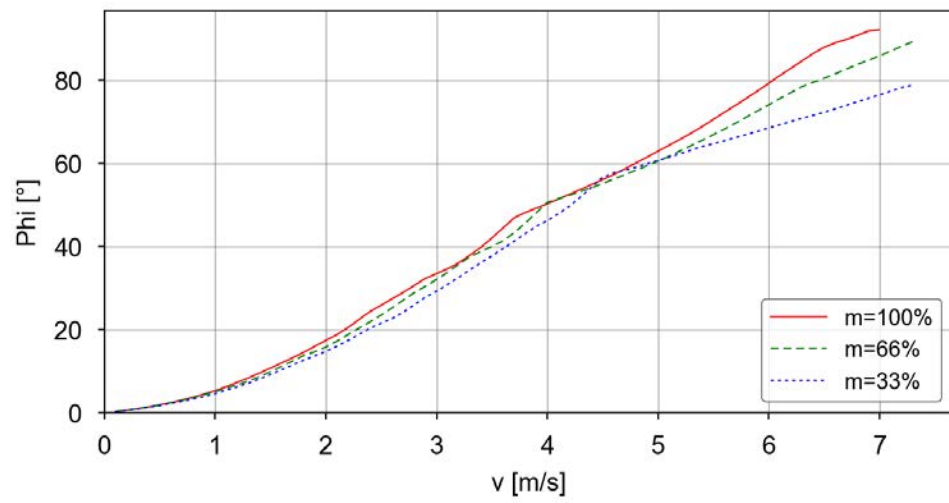

Continues on next page

1 Description

1.9.5 IRB 1300 1.4 m 7 kg

Continued

Category 1, Axis A2

Extension zone 0, stopping distance and stopping time

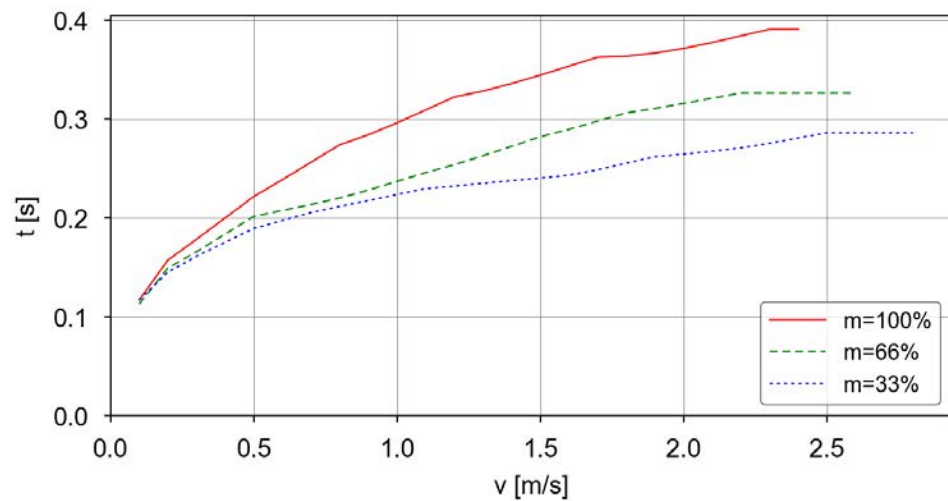
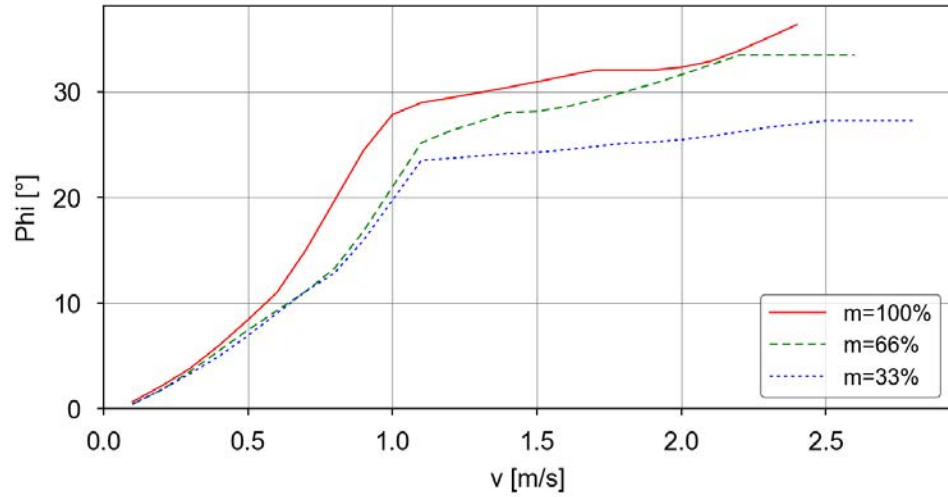

Continues on next page

Extension zone 1, stopping distance and stopping time

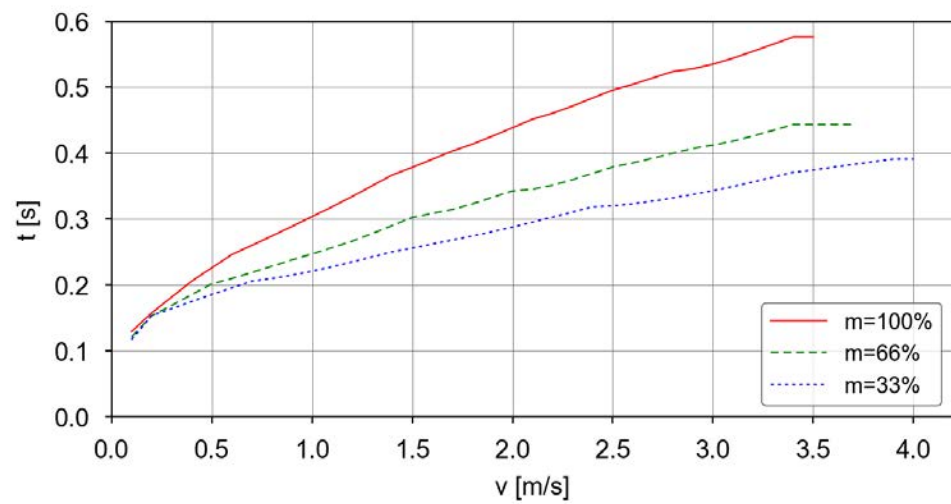
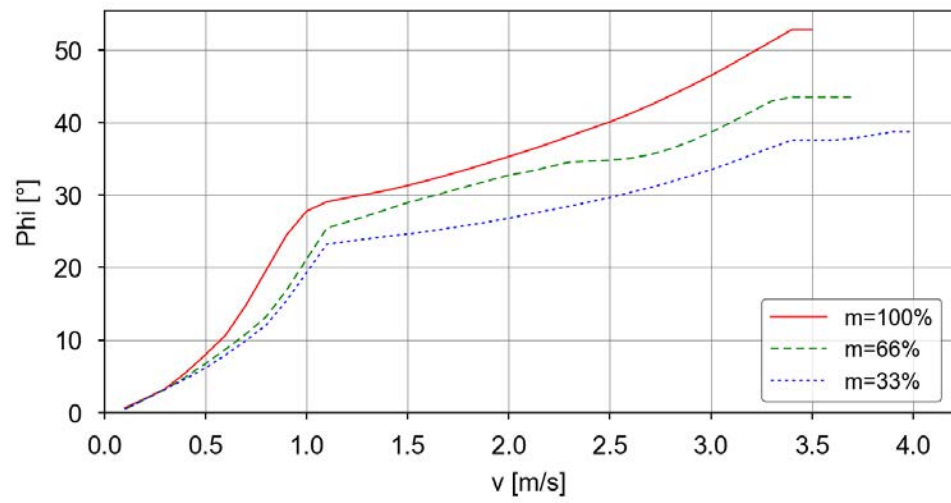

Continues on next page

1 Description

1.9.5 IRB 1300 1.4 m 7 kg

Continued

Extension zone 2, stopping distance and stopping time

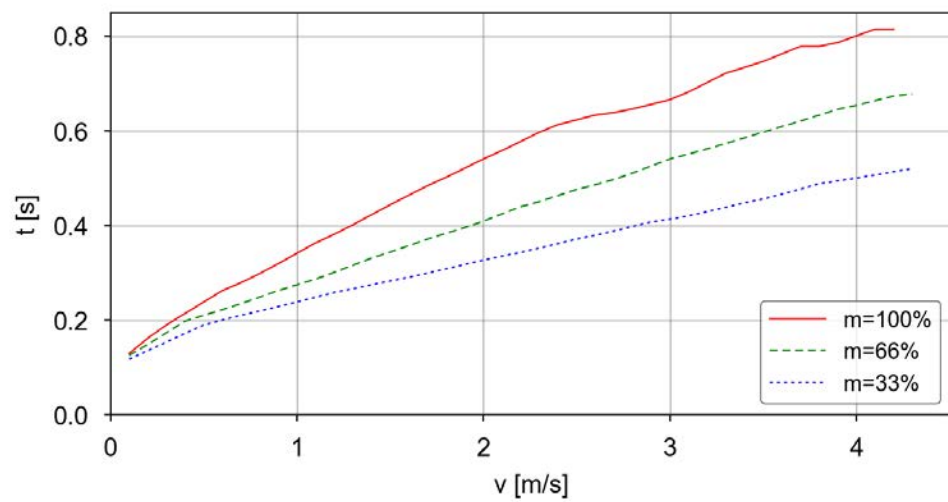
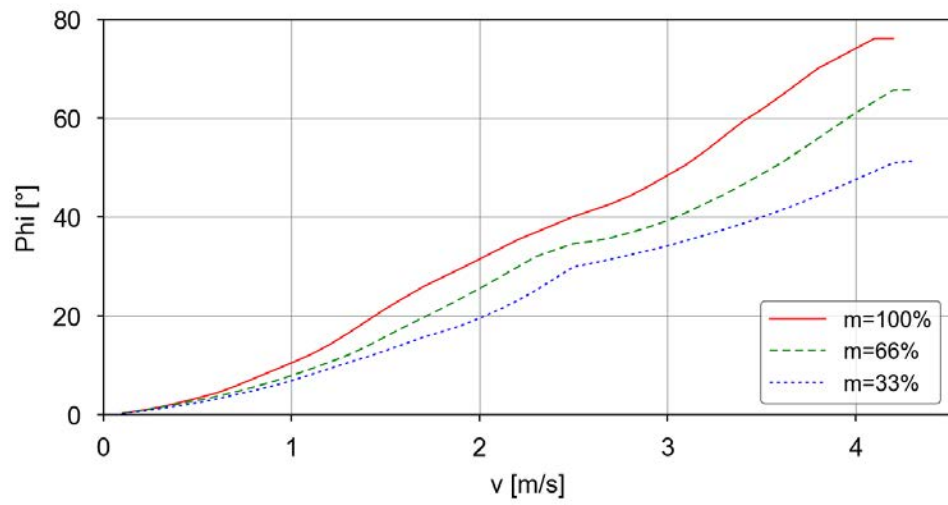

Continues on next page

Category 1, Axis A3

Extension zone 0, stopping distance and stopping time

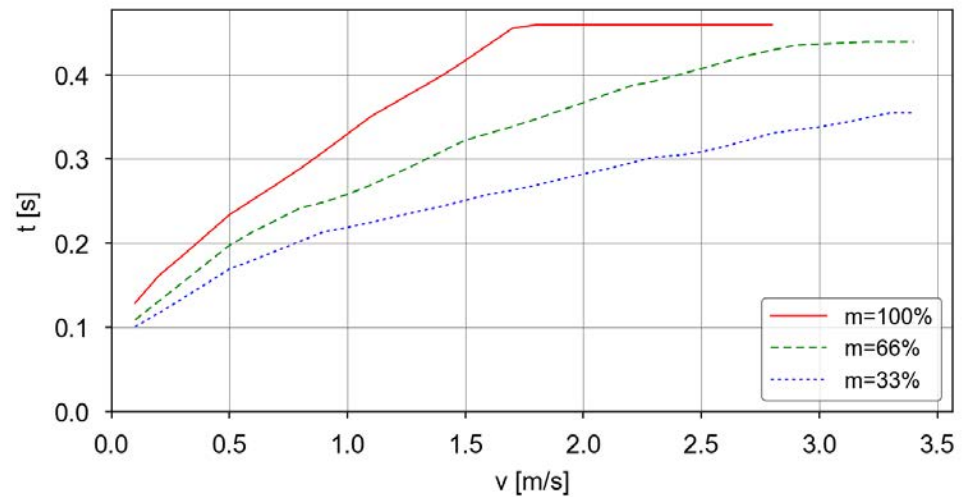
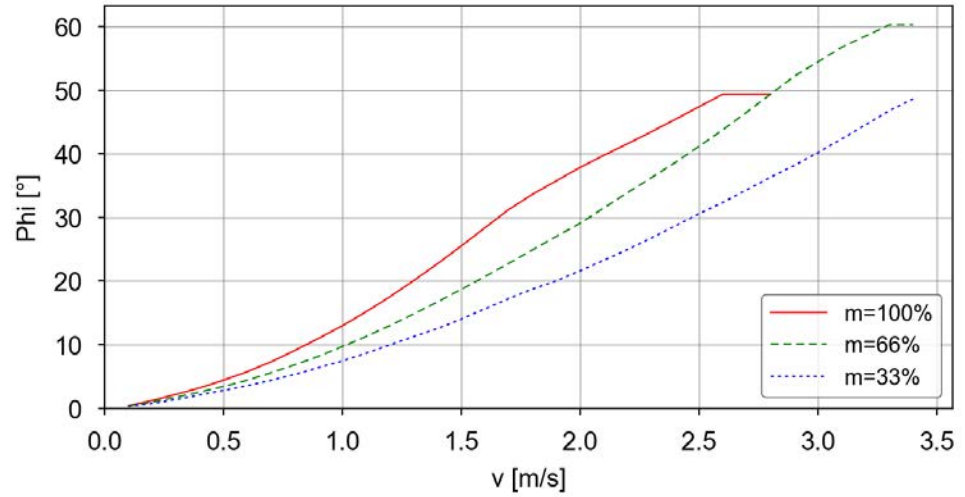

Continues on next page

1 Description

1.9.5 IRB 1300 1.4 m 7 kg

Continued

Extension zone 1, stopping distance and stopping time

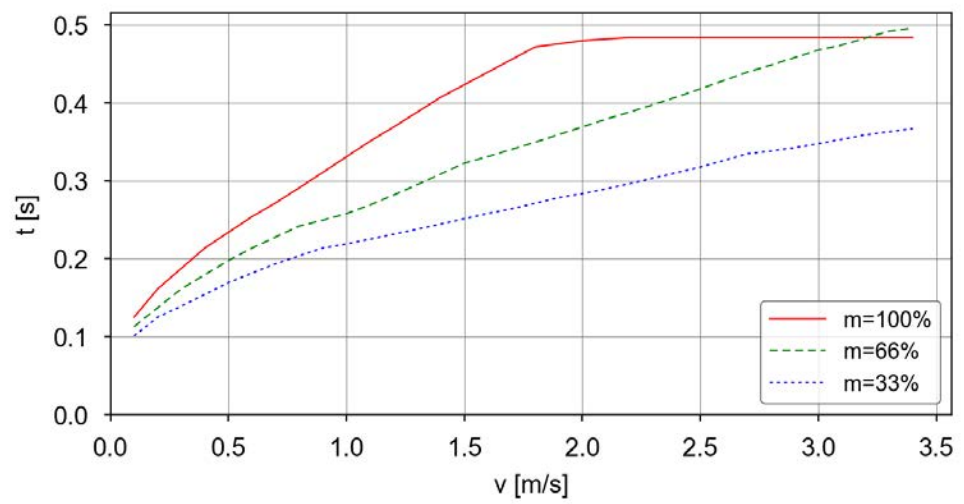
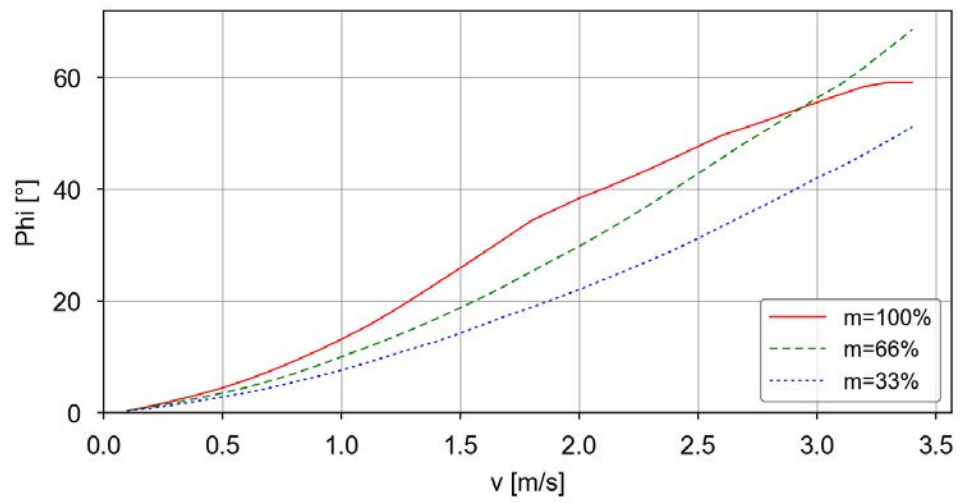

Continues on next page

Extension zone 2, stopping distance and stopping time

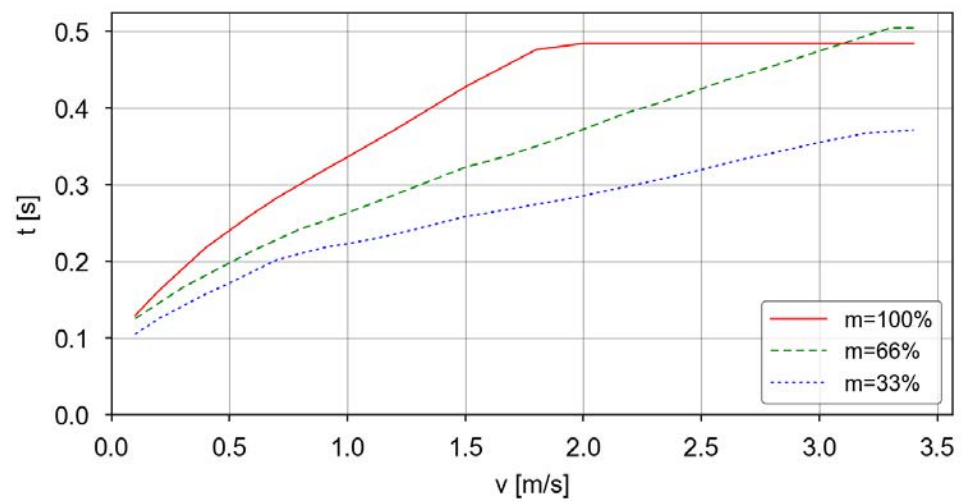
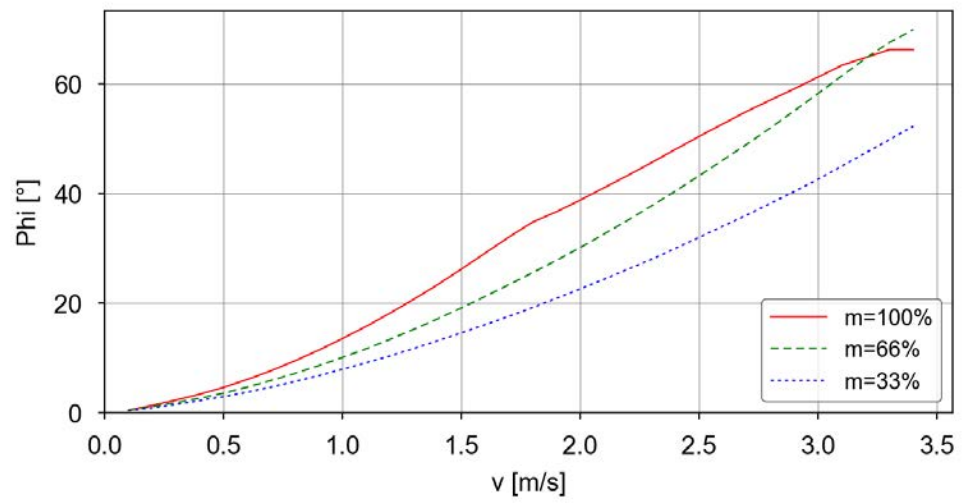

1 Description

1.9.6 IRB 1300 1.4 m 12 kg

1.9.6 IRB 1300 1.4 m 12 kg

Category 0

The following table describes the stopping distance and time for category 0 emergency stop at max speed, with the arm stretched out to the maximum with maximum load. All results are from tests on one moving axis.

Axis	Distance (degrees)	Stop time (s)
1	48.88	0.40
2	18.53	0.20
3	21.92	0.17

Category 1, extension zones

For definitions of the zones, see [Extension zones on page 68](#).

Zone	wcp min (m)	wcp max (m)
0	0	0.467
1	0.467	0.934
2	0.934	max reach

Category 1, Axis A1

Extension zone 0, stopping distance and stopping time

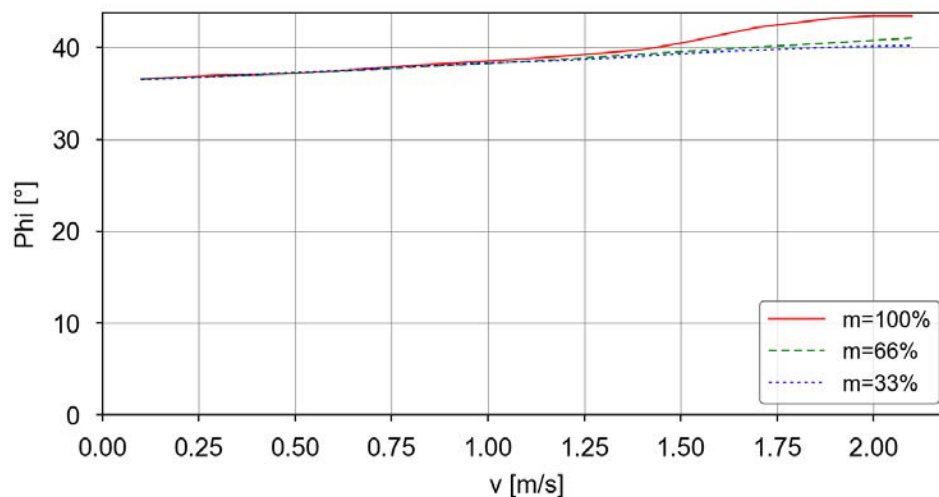

Continues on next page

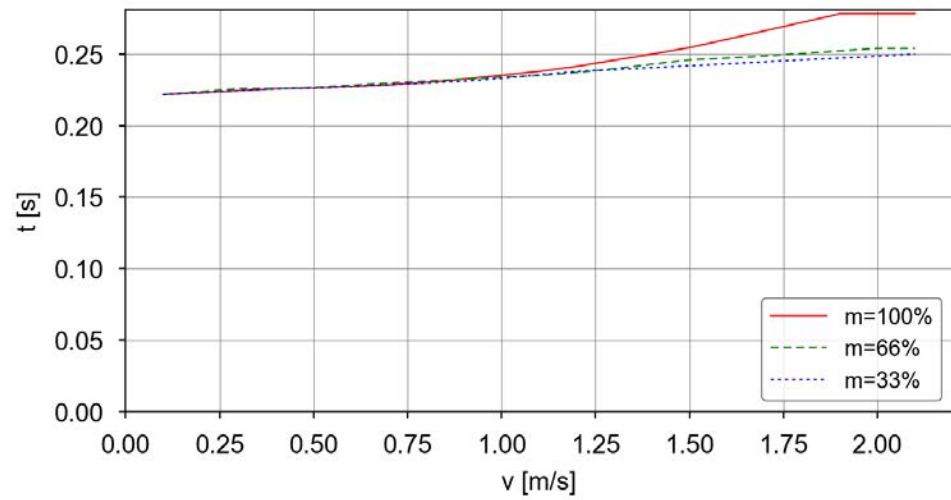

Extension zone 1, stopping distance and stopping time

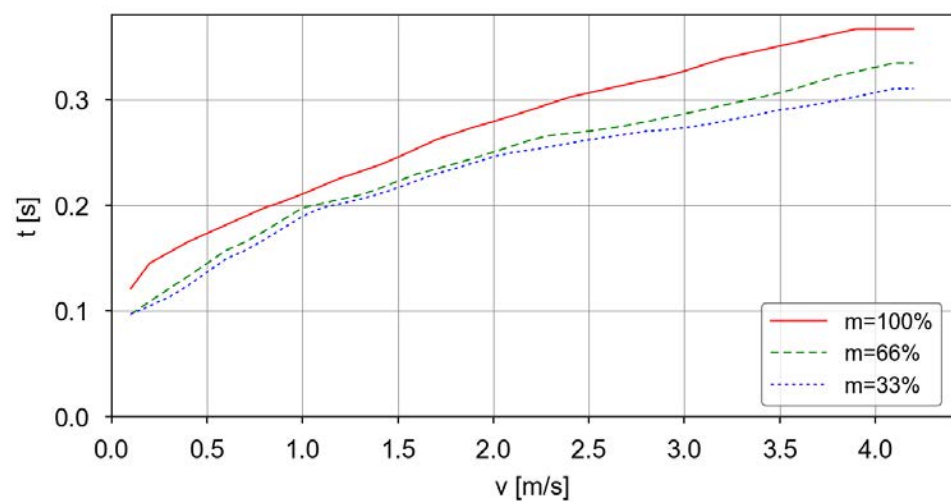
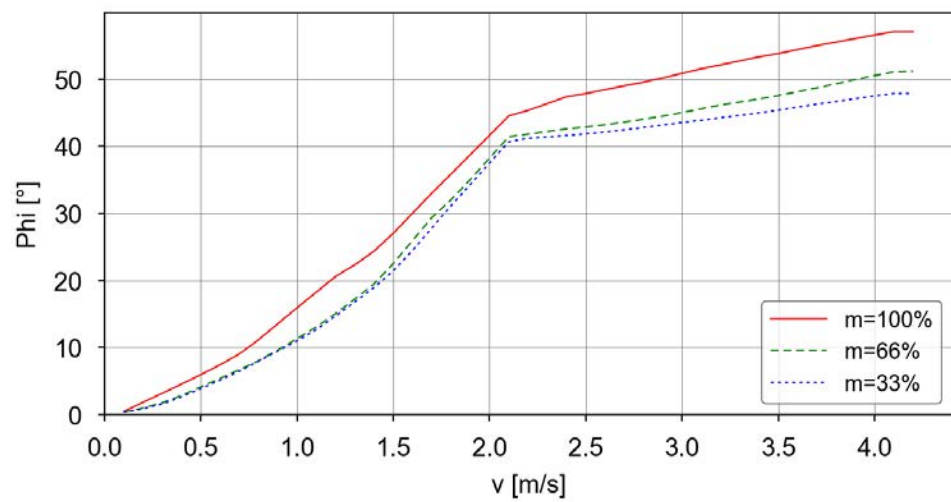

Continues on next page

1 Description

1.9.6 IRB 1300 1.4 m 12 kg

Continued

Extension zone 2, stopping distance and stopping time

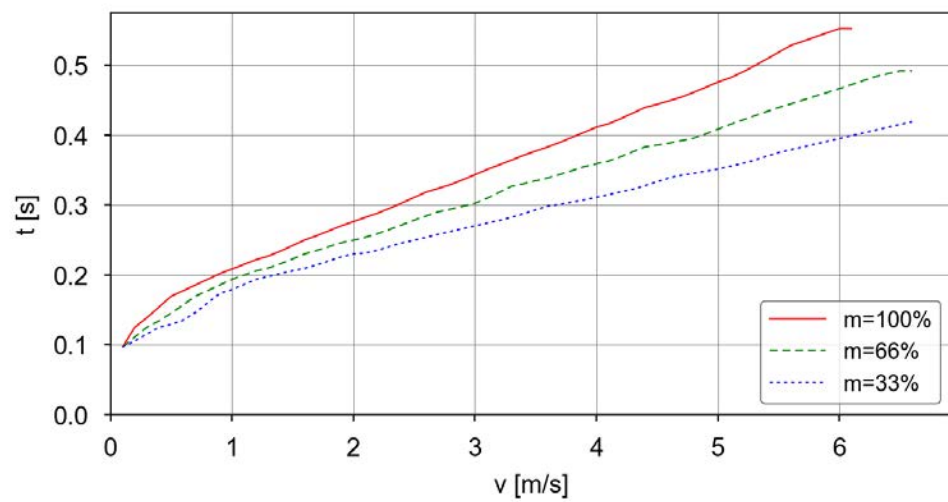
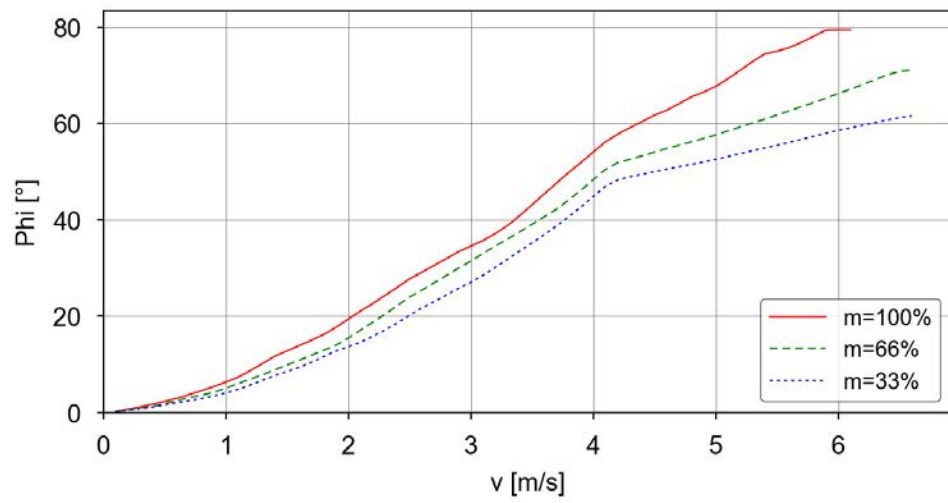

Continues on next page

Category 1, Axis A2

Extension zone 0, stopping distance and stopping time

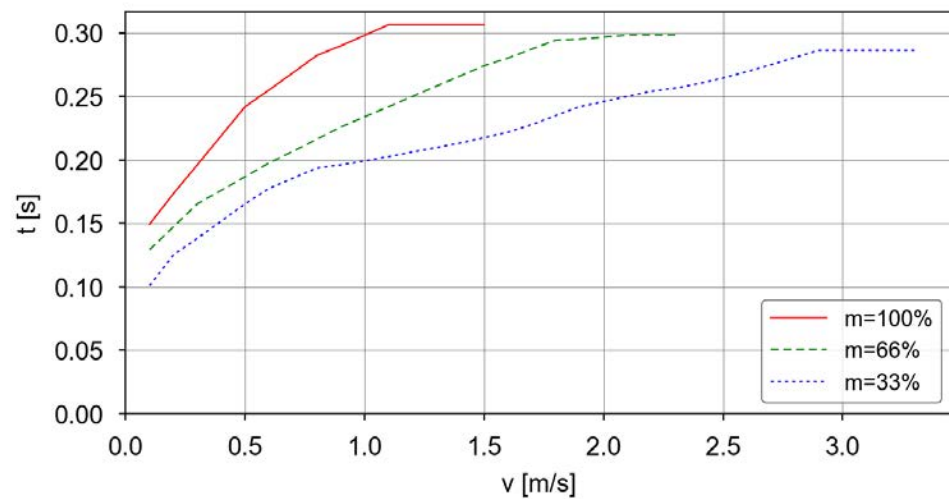
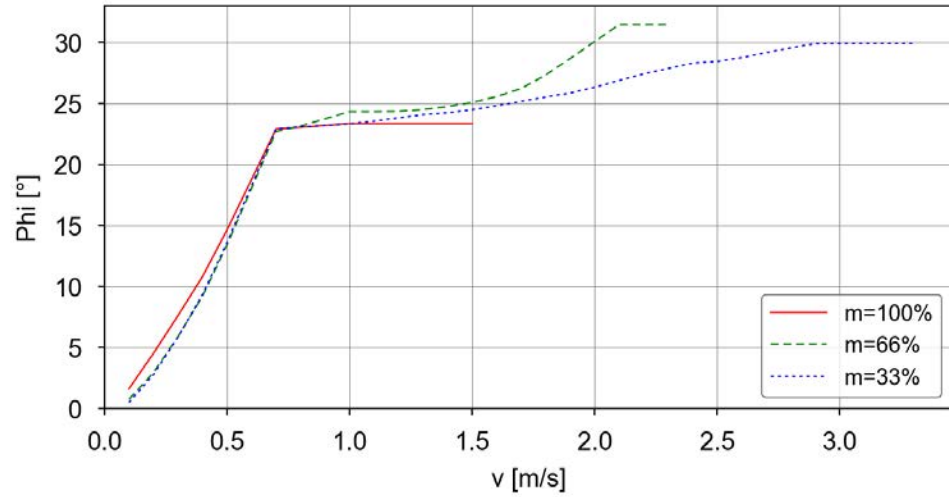

Continues on next page

1 Description

1.9.6 IRB 1300 1.4 m 12 kg

Continued

Extension zone 1, stopping distance and stopping time

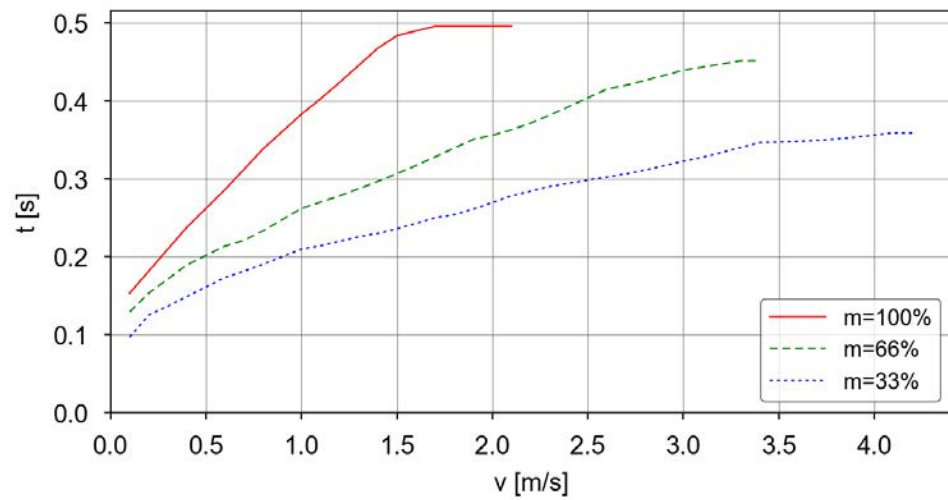
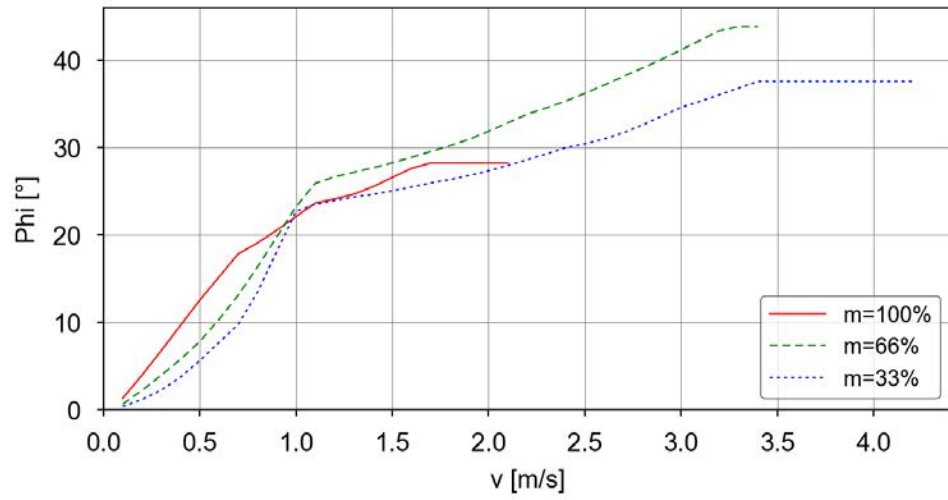

Continues on next page

Extension zone 2, stopping distance and stopping time

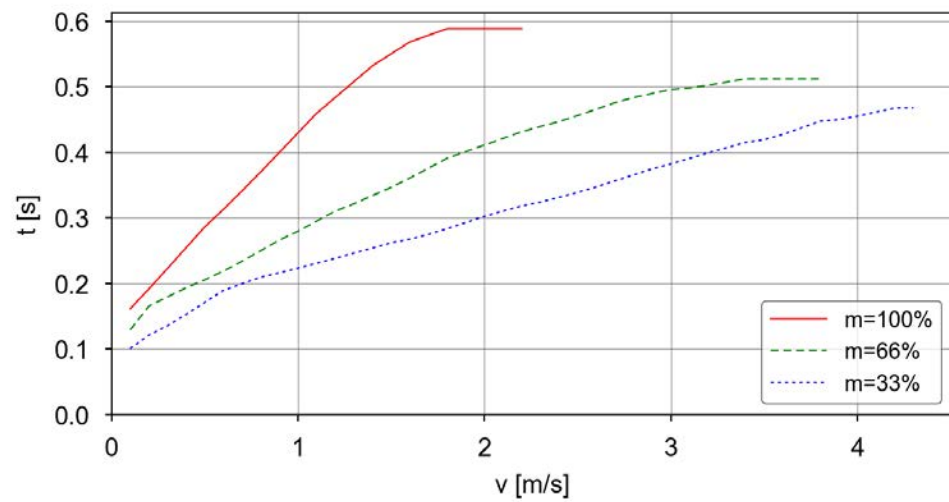
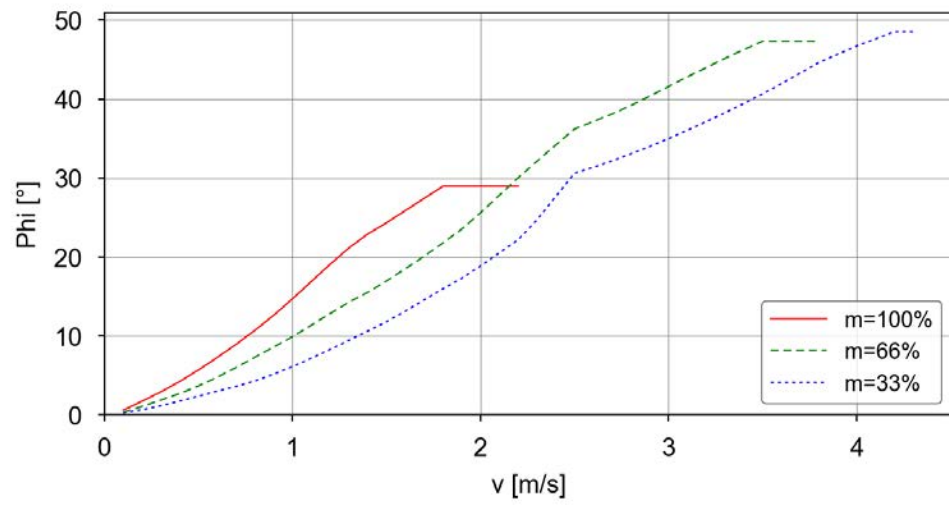

Continues on next page

1 Description

1.9.6 IRB 1300 1.4 m 12 kg

Continued

Category 1, Axis A3

Extension zone 0, stopping distance and stopping time

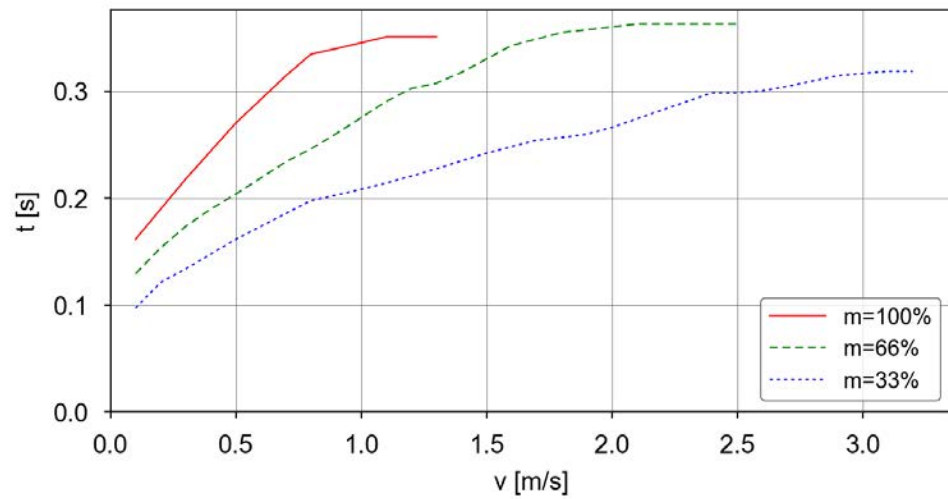
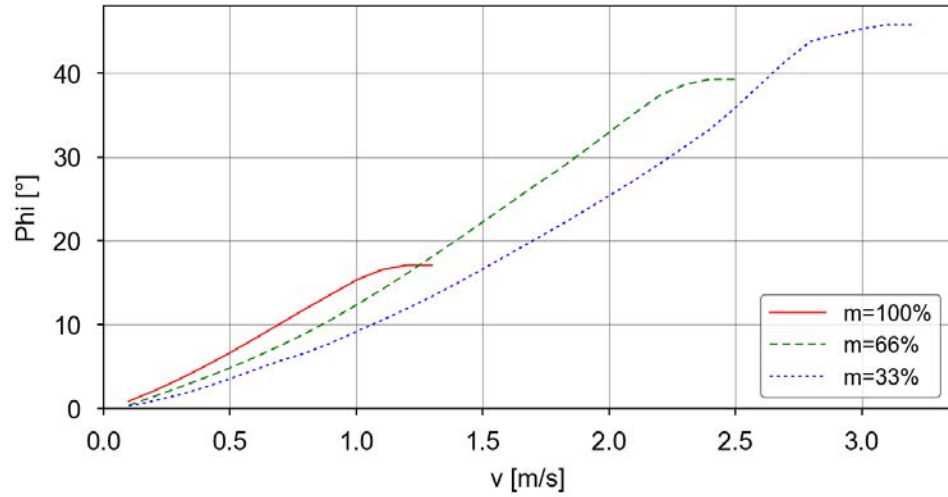

Continues on next page

Extension zone 1, stopping distance and stopping time

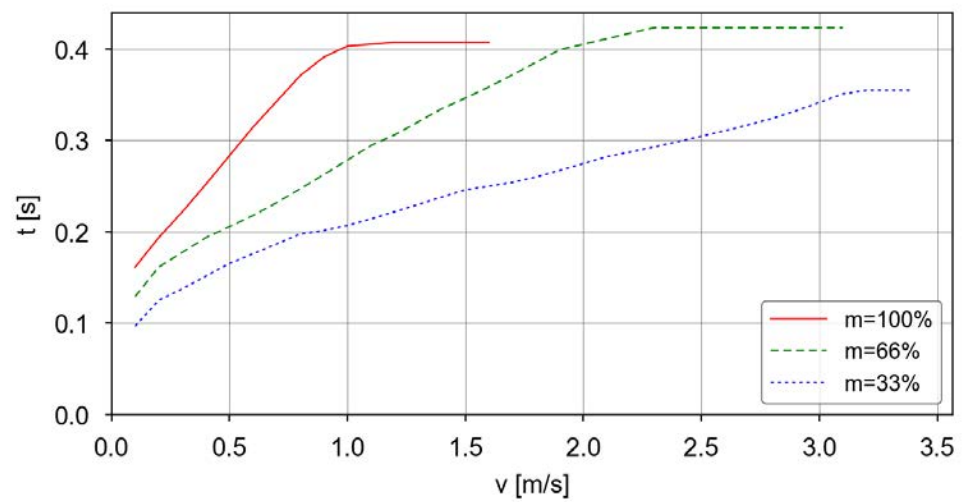
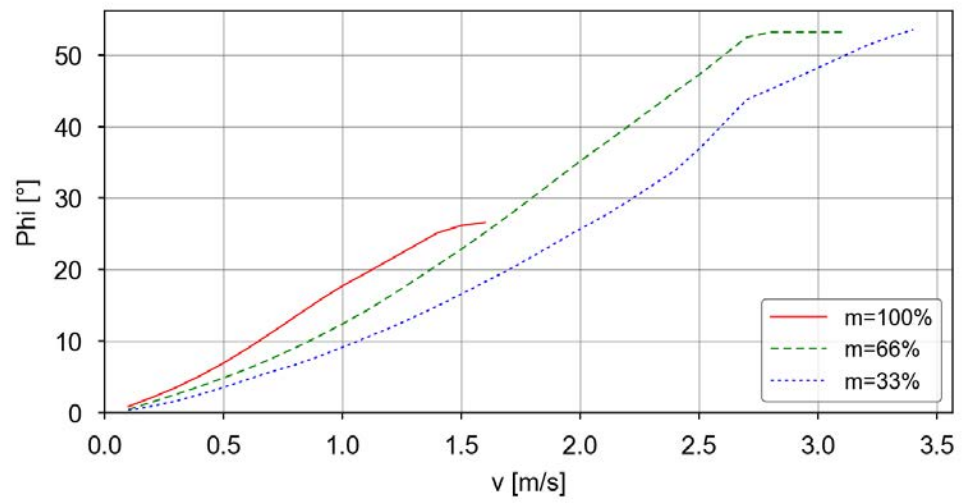

Continues on next page

1 Description

1.9.6 IRB 1300 1.4 m 12 kg

Continued

Extension zone 2, stopping distance and stopping time

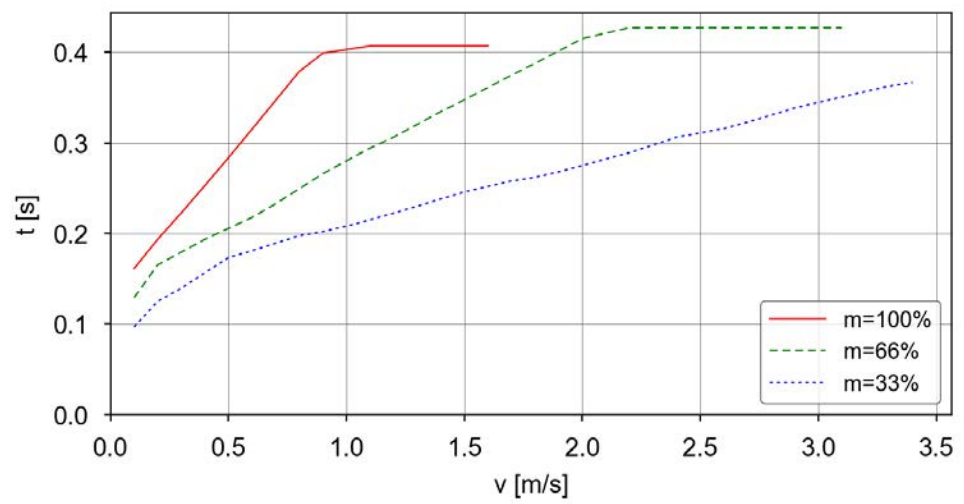
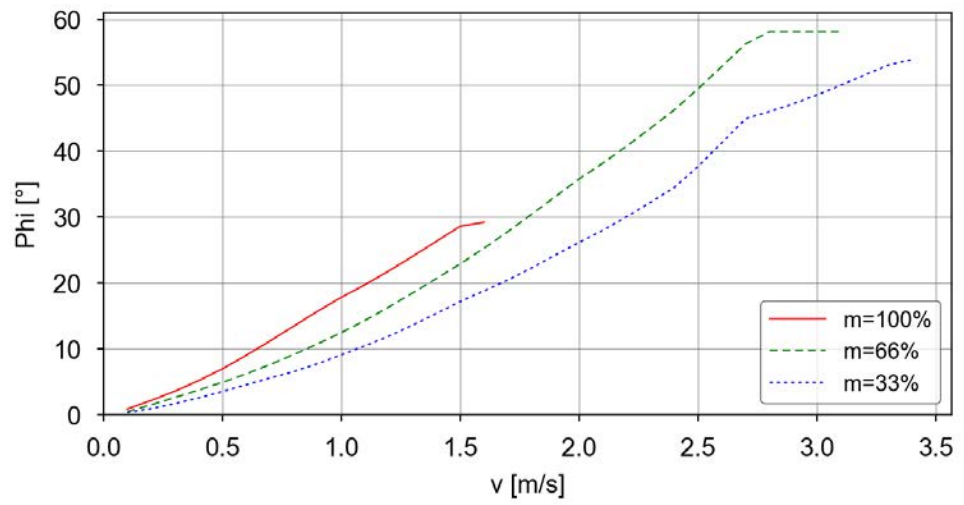

1.10 Customer connections

Introduction to customer connections (without solenoid valve)

The cables for customer connection are integrated in the robot and the connectors are placed on the tubular and at the base. There are two connectors R2.C1 and R2.C3 at the tubular. Corresponding connectors R1.C1 and R1.C3 are located at the base.

There is also connections for Ethernet, one connector R2.C2 at the tubular and the corresponding connector R1.C2 located at the base.

Hose for compressed air is also integrated into the manipulator. There are 4 inlets (R1/8") and 4 outlets (M5) on the tubular.

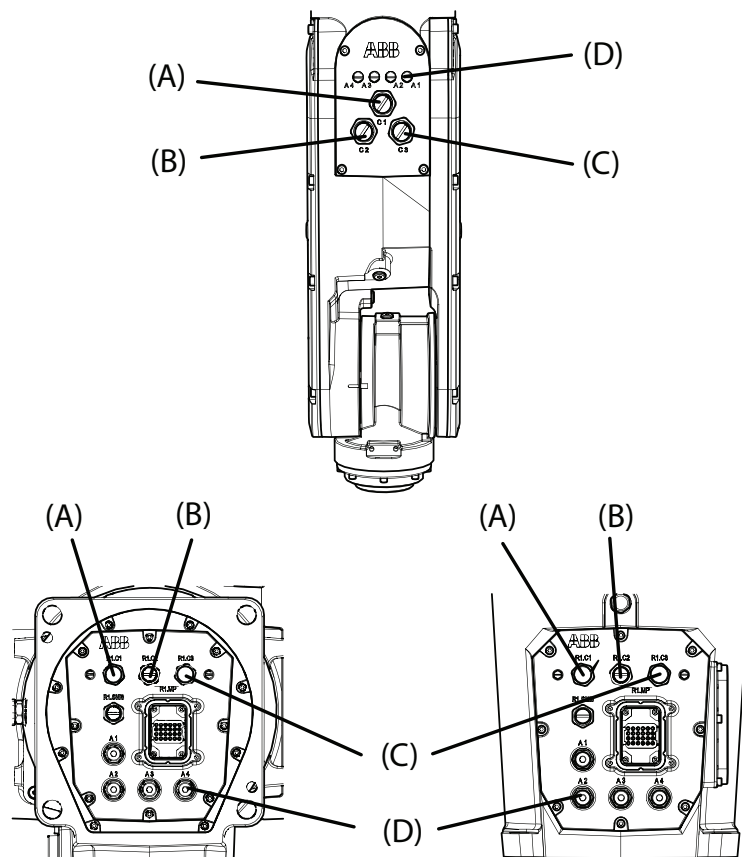

xx2000001007

Position	Connection	Description	Number	Value
A	(R1)R2.C1	Customer power/signal	12 wires	30 V, 1.5 A
B	(R1)R2.C2	Customer power/signal or Ethernet	8 wires	30 V, 1 A or 1 Gbits/s
C	(R1)R2.C3	Customer power/signal	4 wires	42 V DC or 25 V AC, 4 A ⁱ
D	Air	Max. 6 bar	4	Outer diameter of air hose: 6 mm

ⁱ Contact ABB for more information if to use the (R1)R2.C3 connection for an application with a higher voltage.

Continues on next page

1 Description

1.10 Customer connections

Continued

Introduction to customer connections (with solenoid valve)

IRB 1300 with option 3303-3 Solenoid Valves Ext. selected also provides customer connection and Ethernet connection. There are two connectors R2.C1 and R2.C3 at the tubular and corresponding connectors R1.C1 and R1.C3 are located at the base. Connector R2.C2 for Ethernet connection is located at the tubular and the corresponding connector R1.C2 is located at the base.

Hose for compressed air is also integrated into the manipulator. There are 3 inlets at the base (R1/8") and 3 outlets (M5) on the tubular.

IRB 1300 with option 3303-3 Solenoid Valves Ext. selected is also integrated with 1 air inlet for valve at the base and 3 pairs of outlets from valve on the tubular. There is also a silencer on the tubular.

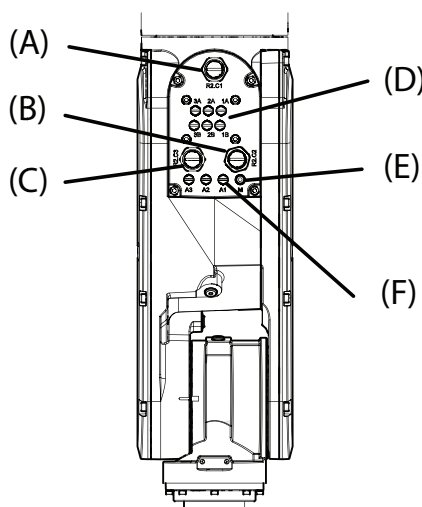

xx2300001443

Position	Connection	Description	Number	Value
A	R2.C1	Customer power/signal	5 wires ¹	30 V, 1.5 A
B	R2.C2	Customer power/signal or Ethernet	8 wires	30 V, 1 A, or 1 Gbits/s
C	R2.C3	Customer power/signal	4 wires	42 V DC or 25 V AC, 4 A ⁱ
D	1A(B) / 2A(B) / 3A(B)	Air from solenoid valve	3 pairs	Max. 6 bar Outer diameter of air hose: 4 mm Air cleanliness requirement: 5 µm or less, dry and clean - base
E	M	Silencer for solenoid valve	1	

¹ 5 wires out of total 12 wires are available for customer power/signal. See details in *Circuit diagram - IRB 1300* for the 5 free wires.

Continues on next page

Position	Connection	Description	Number	Value
F	A1 / A2 / A3	Air	3	Max. 6 bar Outer diameter of air hose: 6 mm

ⁱ Contact ABB for more information if to use the (R1)R2.C3 connection for an application with a higher voltage.

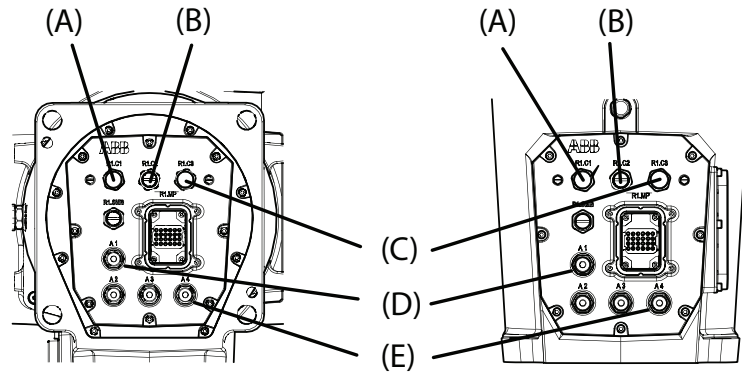

xx2300001369

Position	Connection	Description	Number	Value
A	R1.C1	Customer power/signal	12 wires	30 V, 1.5 A
B	R2.C2	Customer power/signal or Ethernet	8 wires	30 V, 1 A, or 1 Gbits/s
C	R3.C3	Customer power/signal	4 wires	42 V DC or 25 V AC, 4 A ⁱ
D	A1 / A2 / A3	Air	3	Max. 6 bar Outer diameter of air hose: 6 mm
E	A4	Air for solenoid valve	1	Max. 6 bar Outer diameter of air hose: 6 mm Air cleanness requirement: 5 µm or less, dry and clean

ⁱ Contact ABB for more information if to use the (R1)R2.C3 connection for an application with a higher voltage.

Connector kits (optional)

Connector kits, base

R1.C1 and R1.C2 connectors on the base are parts of the CP/CS cable and Ethernet floor cable, respectively. For details about the robot cabling, see "Robot cabling and connection points" in product manual of the manipulator.

Customers need to do wiring when using the R1.C3 connector on the base. Make sure to use the R1.C3 connector in M12 A-code 4p female type.

Continues on next page

1 Description

1.10 Customer connections

Continued

Connector kits, tubular

The table describes the CP/CS and Ethernet (if any) connector kits for tubular.

Position	Description			Art. no.
Connector kits	CP/CS	R2.C1	M12 CPCS Male straight connector kits	3HAC066098-001
			M12 CPCS Male angled connector kits	3HAC066099-001
		R2.C3	M12 CPCS Male straight connector kits	3HAC068412-001
			M12 CPCS Male angled connector kits	3HAC068413-001
	Ethernet	R2.C2	M12 Ethernet CAT6a Male straight connector kits	3HAC067413-001
			M12 Ethernet CAT6a Male angled connector kits	3HAC067414-001

Protection covers

Protection covers for water and dust proofing

Protection covers are delivered together with the robot and must be well fitted to the connectors in any application requiring water and dust proofing.

Always remember to refit the protection covers after removing them.

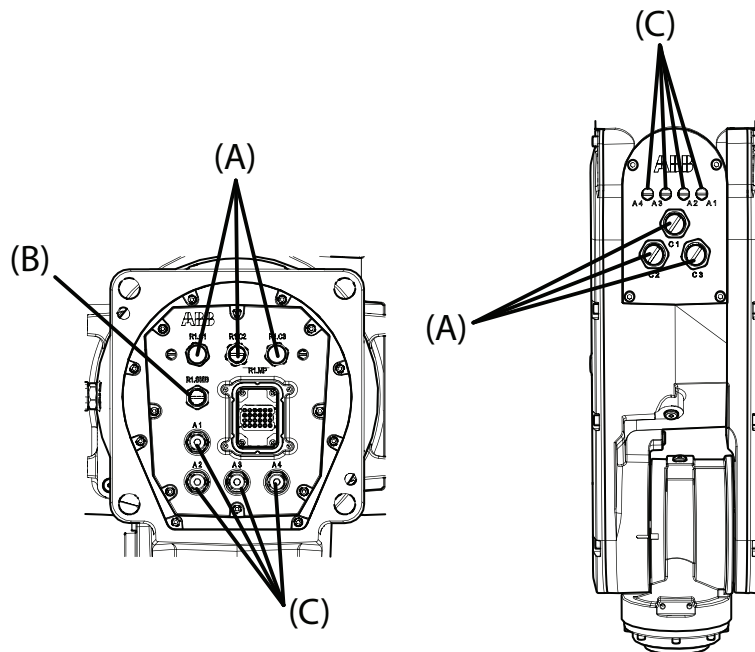

xx2000001008



Note

IRB 1300 with option 3303-3 Solenoid Valves Ext. selected also has protection covers on 3 pairs of the connectors used for air from solenoid valve, which are the same as those use for air hose connectors.

2 Specification of variants and options

2.1 Introduction to variants and options

General

The different variants and options for the IRB 1300 are described in the following sections. The same option numbers are used here as in the specification form.

The variants and options related to the robot controller are described in the product specification for the controller.

2 Specification of variants and options

2.2 Manipulator

2.2 Manipulator

Manipulator variants

Option	IRB Type	Handling capacity (kg)	Reach (m)
3300-8	1300	11	0.9
3300-9	1300	10	1.15
3300-10	1300	7	1.4
3300-65	1300	12	1.4

Manipulator color

Option	Description	RAL code ⁱ
209-202	ABB Graphite White std Standard color	RAL 7035
209-2	ABB white standard Standard color with protection option 3351-4 Cleanroom 4	RAL 9003

ⁱ The colors can differ depending on supplier and the material on which the paint is applied.

Media & Communication

When 3303-1 Parallel & Air is selected then 3304-1 and 3305-1 options are activated for selecting.

When 3303-2 Ethernet, Parallel, Air is selected then 3304-1, 3305-1, 3306-1 and 3307-1 are activated for selecting.

Option	Type	Description
3303-1	Parallel & Air	Includes CP/CS (C1) and air.
3303-2	Ethernet, Parallel, Air	Includes CP/CS (C1,C3) + Ethernet (C2), and air.
3303-3	Solenoid Valves Ext.	Includes CP/CS (C1,C3) + Ethernet(C2), air and solenoid valve.

Manipulator protection

Option	Description
3350-400	Base 40, IP40
3350-670	Base 67, IP67
3351-4	Clean Room 4, ISO Class 4
3352-10	Foundry Plus2 67, IP67

Continues on next page



Note

Base 40 includes IP40, according to standard IEC 60529.

Base 67 includes IP67, according to standard IEC 60529.

Clean Room class 4 includes ISO class 4 standard, according to DIN EN ISO 14644-1, -14. The robot selected with option Clean Room is also available for IP54 applications, according to standard IEC 60529.

Robot cabling routing

Option	Description
3309-1	Under the base
3309-2	From side of base

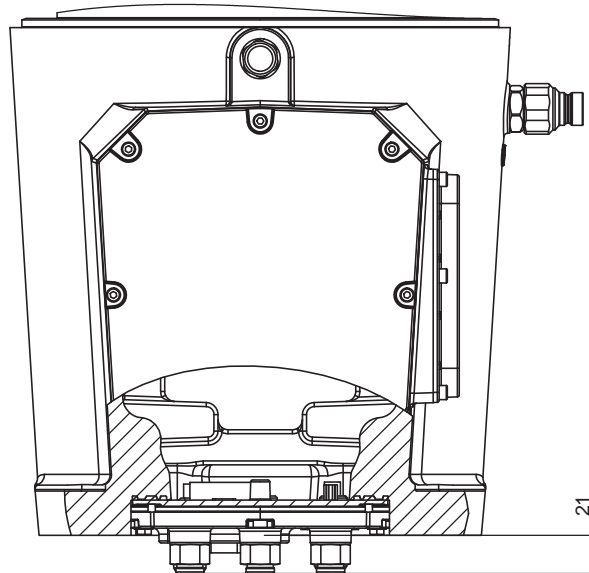

xx2100002865

Connector kits manipulator

The kit consists of connectors, pins and sockets.

Option	Description
3304-1	Male-type, Straight arm connector kits REQUIRES: Media & Communication 3303-x
3305-1	Male-type, Angled arm connector kits REQUIRES: Media & Communication 3303-x
3306-1	Male-type, Straight arm Ethernet connector kits REQUIRES: 3303-2 Ethernet, Parallel, Air
3307-1	Male-type, Angled arm Ethernet connector kits REQUIRES: 3303-2 Ethernet, Parallel, Air

Continues on next page

2 Specification of variants and options

2.2 Manipulator

Continued

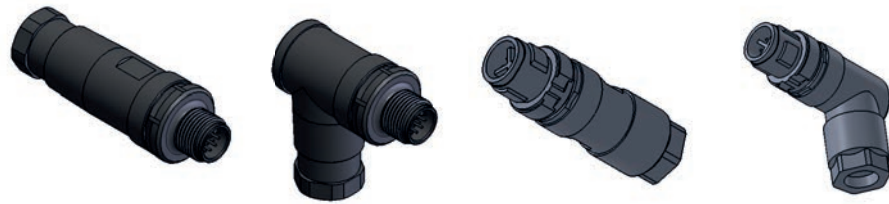

Straight connector kits

Angled connector kits

Straight Ethernet connector kits

Angled Ethernet connector kits

xx190000140



Note

The image shown here is indicative only. If there is inconsistency between the image and the actual product, the actual product shall govern.

The kits are designed and used for connectors on upper arm.

Warranty

For the selected period of time, ABB will provide spare parts and labour to repair or replace the non-conforming portion of the equipment without additional charges. During that period, it is required to have a yearly Preventative Maintenance according to ABB manuals to be performed by ABB. If due to customer restrains no data can be analyzed in the ABB Ability service *Condition Monitoring & Diagnostics* for robots with OmniCore controllers, and ABB has to travel to site, travel expenses are not covered. The Extended Warranty period always starts on the day of warranty expiration. Warranty Conditions apply as defined in the Terms & Conditions.



Note

This description above is not applicable for option *Stock warranty* [438-8]

Option	Type	Description
438-1	Standard warranty	Standard warranty is 12 months from <i>Customer Delivery Date</i> or latest 18 months after <i>Factory Shipment Date</i> , whichever occurs first. Warranty terms and conditions apply.
438-2	Standard warranty + 12 months	Standard warranty extended with 12 months from end date of the standard warranty. Warranty terms and conditions apply. Contact Customer Service in case of other requirements.
438-4	Standard warranty + 18 months	Standard warranty extended with 18 months from end date of the standard warranty. Warranty terms and conditions apply. Contact Customer Service in case of other requirements.
438-5	Standard warranty + 24 months	Standard warranty extended with 24 months from end date of the standard warranty. Warranty terms and conditions apply. Contact Customer Service in case of other requirements.

Continues on next page

2 Specification of variants and options

2.2 Manipulator Continued

Option	Type	Description
438-6	Standard warranty + 6 months	Standard warranty extended with 6 months from end date of the standard warranty. Warranty terms and conditions apply.
438-7	Standard warranty + 30 months	Standard warranty extended with 30 months from end date of the standard warranty. Warranty terms and conditions apply.
438-8	Stock warranty	<p>Maximum 6 months postponed start of standard warranty, starting from factory shipment date. Note that no claims will be accepted for warranties that occurred before the end of stock warranty. Standard warranty commences automatically after 6 months from <i>Factory Shipment Date</i> or from activation date of standard warranty in WebConfig.</p> <p> Note Special conditions are applicable, see <i>Robotics Warranty Directives</i>.</p>

2 Specification of variants and options

2.3 Floor cables

2.3 Floor cables

Manipulator cable - Straight

Option	Lengths
3200-1	3 m
3200-2	7 m
3200-3	15 m



xx2100001122

Manipulator cable - Angled

Option	Lengths
3209-1	Angled type connector



xx2100001123

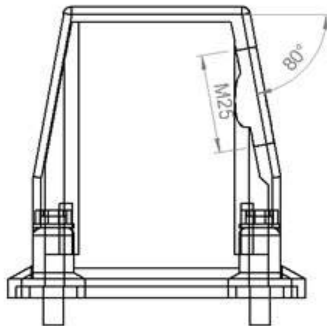

xx2100001124

Continues on next page

Bending radius for static floor cables

The minimum bending radius is 10 times the cable diameter for static floor cables.

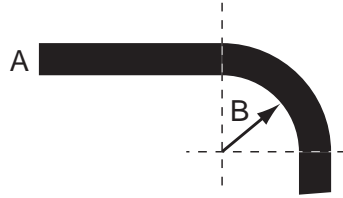

xx1600002016

A	Diameter
B	Diameter x10

Mains cable

Option	Lengths	Description
3203-1	EU mains cable, 3 m	Cable assembly with CEE7/VII line-side plug
3203-5	CN mains cable, 3 m	Cable assembly with CPCS-CCC line-side plug
3203-6	AU mains cable, 3 m	Cable assembly with AS/NZS 3112 line-side
3203-7	All regions cable, 5 m	Cable assembly without line-side plug

Connection of parallel communication

Required 3303-1 Parallel & Air or 3303-2 Ethernet, Parallel, Air.

Option	Lengths
3201-1	3 m
3201-2	7 m
3201-3	15 m

Connection of Ethernet

Required 3303-2 Ethernet, Parallel, Air and occupies 1 Ethernet port.

Option	Lengths
3202-2	7 m
3202-3	15 m

This page is intentionally left blank

3 Accessories

General

There is a range of tools and equipment available.

Basic software and software options for robot and PC

For more information, see *Application manual - Controller software OmniCore*, *Product specification - OmniCore C line* and *Product specification - OmniCore E line*.

This page is intentionally left blank

Index

A

Absolute Accuracy, 37
Absolute Accuracy, calibration, 35
ambient humidity
 operation, 19
 storage, 19
ambient temperature
 operation, 19
 storage, 19
Axis Calibration
 calibration tool
 examining, 38

C

calibration
 Absolute Accuracy type, 34
 standard type, 34
calibration, Absolute Accuracy, 35
calibration marks, 41
calibration position
 scales, 41
calibration scales, 41
CalibWare, 34
compensation parameters, 37

D

dimensions
 robot, 55

E

equipment, robot, 55
extension zone concept, 68
extension zone limits, 68
extra equipment, 55

F

fitting, equipment, 55
foundation
 requirements, 18

H

humidity
 operation, 19
 storage, 19

I

installation
 equipment, 55

L

limitations, 69
load, 67
loads on foundation, 16

M

mounting, equipment, 55

O

operating conditions, 19
options, 113

P

product standards, 29
protection classes, 19
protection type, 19

R

requirements on foundation, 18
robot
 dimensions, 55
 equipment, fitting, 55
 protection class, 19
 protection types, 19
 technical data, 16
 working range, 23

S

safety standards, 29
scales on robot, 41
securing the robot to foundation, attachment screws, 33
speed, 69
standards, 29
 ANSI, 29
 CAN, 29
standard warranty, 116
stock warranty, 116
stopping distance, 69
stopping time, 69
storage conditions, 19
sync marks, 41

T

technical data
 robot, 16
temperatures
 operation, 19
 storage, 19
torques on foundation, 16
turning radius, 27

V

variants, 113

W

warranty, 116
wcp, 68
weight, 16
working range, 27
 robot, 23



ABB AB

Robotics & Discrete Automation

S-721 68 VÄSTERÅS, Sweden

Telephone +46 10-732 50 00

ABB AS

Robotics & Discrete Automation

Nordlysvegen 7, N-4340 BRYNE, Norway

Box 265, N-4349 BRYNE, Norway

Telephone: +47 22 87 2000

ABB Engineering (Shanghai) Ltd.

Robotics & Discrete Automation

No. 4528 Kangxin Highway

PuDong New District

SHANGHAI 201319, China

Telephone: +86 21 6105 6666

ABB Inc.

Robotics & Discrete Automation

1250 Brown Road

Auburn Hills, MI 48326

USA

Telephone: +1 248 391 9000

abb.com/robotics