



Installation and Service manual SpotPack and DressPack

Articulated robot

IRB 6600
IRB 6650
IRB 6650S
IRB 7600
S4Cplus



Installation and Service manual SpotPack and DressPack

IRB 6600

IRB 6650

IRB 6650S

IRB 7600

Document ID: 3HAC 17667-1

Revision: A

The information in this manual is subject to change without notice and should not be construed as a commitment by ABB. ABB assumes no responsibility for any errors that may appear in this manual.

Except as may be expressly stated anywhere in this manual, nothing herein shall be construed as any kind of guarantee or warranty by ABB for losses, damages to persons or property, fitness for a specific purpose or the like.

In no event shall ABB be liable for incidental or consequential damages arising from use of this manual and products described herein.

This manual and parts thereof must not be reproduced or copied without ABB's written permission, and contents thereof must not be imparted to a third party nor be used for any unauthorized purpose. Contravention will be prosecuted.

Additional copies of this manual may be obtained from ABB at its then current charge.

© Copyright 2004 ABB All right reserved.

ABB Automation Technologies AB
Robotics
SE-721 68 Västerås
Sweden

About this document	5
What is DressPack/SpotPack?	7
1 Reference information, SpotPack	11
1.1 Introduction	11
1.2 Unit conversion.	12
1.3 Screw joints	13
1.4 Weight specifications	16
1.5 Toolkits, SpotPack/DressPack	17
1.6 Lifting equipment and lifting instructions	19
2 Installation	21
2.1 Introduction	21
2.2 General installation procedure	22
2.3 Inspection during programming and test-running	25
2.4 DressPack lower arm	27
2.4.1 Installation of DressPack lower arm	27
2.4.2 Inspection, DressPack lower arm	36
2.5 DressPack upper arm	38
2.5.1 Installation of DressPack upper arm.	38
2.5.2 Inspection, DressPack upper arm	45
2.5.3 Adjustments	50
2.5.3.1 Adjustment of DressPack upper arm.	50
2.6 DressPack floor	53
2.6.1 Installation of DressPack floor	53
2.6.2 Inspection, DressPack floor	61
2.7 Water & air unit	62
2.7.1 Installation of Water and Air unit, SpotPack	62
2.7.2 Mechanical flow switch	67
2.7.3 Digital flow switch - Introduction	68
2.7.4 Digital flow switch - Settings	70
2.7.5 Pressure switch	72
2.7.6 Proportional valve	73
2.7.7 Split box	74
2.8 Power unit	75
2.8.1 Lifting the power unit	75
2.8.2 Installation of power unit, std.	76
3 Maintenance	81
3.1 Introduction	81
3.2 Maintenance schedules and component lives	82
3.2.1 Maintenance schedule, SpotPack	82
3.3 Inspection activities	83
3.3.1 Preventive inspection of all cables, SpotPack	83
3.3.2 Preventive inspection, DressPack upper arm	85
3.3.3 Preventive inspection of water and air unit	91
3.3.4 Preventive inspection of power unit.	94
3.4 Cleaning activities	97
3.4.1 Cleaning, DressPack upper arm	97
3.4.2 Cleaning, water and air unit	99
4 Repairs	101
4.1 Introduction	101

Table of Contents

4.2 DressPack upper arm	102
4.2.1 Disassembly of DressPack upper arm	102
4.2.2 Assembly of DressPack upper arm	108
4.2.3 Replacement of damper	116
4.2.4 Replacement of hose reinforcement	118
4.2.5 Replacement of slide sleeves	120
4.2.6 Adjusting the spring tension of the retracting unit	122
4.3 DressPack lower arm	127
4.3.1 Disassembly of DressPack lower arm	127
4.3.2 Assembly of DressPack lower arm	131
4.4 Water & Air unit	137
4.4.1 Replacement of Air supply circuit, std.	137
4.4.2 Replacement of Water-in circuit, std	140
4.4.3 Replacement of Water-return circuit, std	143
4.4.4 Replacement of air filter element	147
4.5 Power unit	148
4.5.1 Replacement of power unit, SpotPack	148
4.5.2 Replacement of circuit breaker QB101	150
4.5.3 Replacement of earth fault protection	152
4.5.4 Replacement of minicontactors K101, K103	154
4.5.5 Replacement of contactor QC101	156
4.5.6 Replacement of timer VE101	159

5 Spare Parts	161
----------------------	------------

5.1 Introduction	161
5.2 Abbreviations	162
5.3 Upper arm harness	164
5.3.1 DressPack, upper arm, std	164
5.3.2 Retracting unit, IRB 66x0 & 7600, std	167
5.4 Lower arm harness	168
5.4.1 DressPack, lower arm, std	168
5.5 DressPack lower arm, cable clamp attachment sets, std	171
5.5.1 DressPack lower arm, cable clamp attachments	171
5.6 Floor harness	173
5.6.1 DressPack, floor, std	173
5.6.2 Connection kits, std	176
5.7 Water & Air unit, std	178
5.7.1 Water & Air unit, std	178
5.7.2 Air supply circuits	180
5.7.3 Water-in circuits, std	181
5.7.4 Water-return circuits, std	182
5.8 Power unit	183
5.8.1 Power unit, std	183

About this document

About this manual

This manual contains instructions for

- mechanical and electrical work of the SpotPack/DressPack systems
- maintenance of the SpotPack/DressPack systems
- mechanical and electrical repair of the the SpotPack/DressPack systems

Usage

This manual should be used during

- installation on the SpotPack/DressPack systems
- maintenance on the SpotPack/DressPack systems
- repair work on the SpotPack/DressPack systems

Who should read this manual?

This manual is intended for

- installation personnel
- maintenance personnel
- repair personnel

Prerequisites

The reader should...

- be a trained maintenance/repair craftsman.
- have the required knowledge of mechanical and electrical installation/repair/maintenance work.

Organization of chapters

This manual is organized in the following chapters:

Chapters	Contents
System description	General description of the SpotPack/DressPack system.
Reference information	General information about screw joints, tightening torques, weight specifications, toolkits and lifting instructions.
Installation	Descriptions of mechanical installation and electrical connections.
Maintenance	Descriptions of all required preventive maintenance procedures including intervals.
Repair	Descriptions of all recommended repair procedures including spare parts and foldouts.

References

Reference	Document ID
Circuit diagram	3HAC 17669-1
Circuit diagram	3HAC 17669-2

Revisions

Revision	Description
A	Second edition. This manual replaces two earlier manuals which contained either SpotPack or DressPack. This manual contains both the IRB6600 and 7600 SpotPack/DressPack systems.

What is DressPack/SpotPack?

General

DressPack/SpotPack is a utility package used to supply the manipulator with the required media, primarily for spot welding applications.

Different versions of DressPack/SpotPack exist for different robot models. This manual contains information about DressPack/SpotPack for the IRB 66x0 and 7600 models. The contents of each robot specific DressPack/SpotPack package differ slightly, but the principles are identical.

DressPack/SpotPack types

DressPack/SpotPack are available in different types intended for different applications. These are listed below:

- Type H, material handling applications
- Type S, spot welding applications with manipulator carried pneumatic transformer gun
- Type HS, spot welding applications with pedestal mounted pneumatic transformer gun
- Type Se, spot welding applications with manipulator carried electrical servo driven transformer gun
- Type HSe, spot welding applications with pedestal mounted electrical servo driven transformer gun

Available options and selections for each type are specified in the *Product Specification* document.

The parts included are specified in detail (technical specifications, article numbers, etc) in chapter *Spare Parts*.

Type H

This Dress-package is intended for *material handling applications*.

The figure shows the configuration of type H, and its contents are specified in detail in the Product Specification.

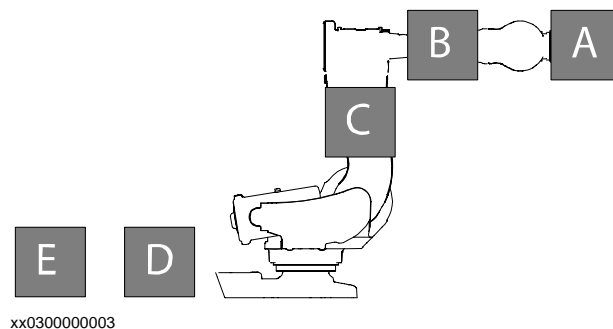

A	Gripper on manipulator (supplied by user)
B	DressPack upper arm
C	DressPack lower arm

What is DressPack/SpotPack?

D	DressPack floor
E	Robot controller cabinet

Type S

This Spot-package is intended for *spot welding applications* where a pneumatic transformer gun is fitted onto the turning disk of the manipulator.

The figure shows the configuration of type S. Its contents are specified in detail in the Product Specification.

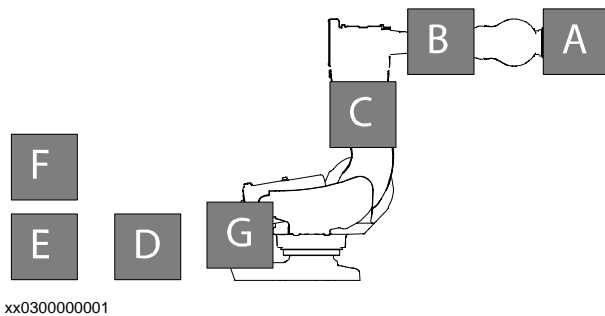

xx030000001

A	Pneumatic transformer gun (supplied by user)
B	DressPack upper arm
C	DressPack lower arm
D	DressPack floor
E	Robot controller cabinet
F	Power unit
G	Water and air unit

Type HS

This Spot-package is intended for *spot welding applications* where a pneumatic transformer gun is fitted onto a separate pedestal. The robot system controls the transformer gun on the pedestal and the manipulator handles the workpiece in a gripper.

The figure shows the configuration of type HS. Its contents are specified in detail in the Product Specification.

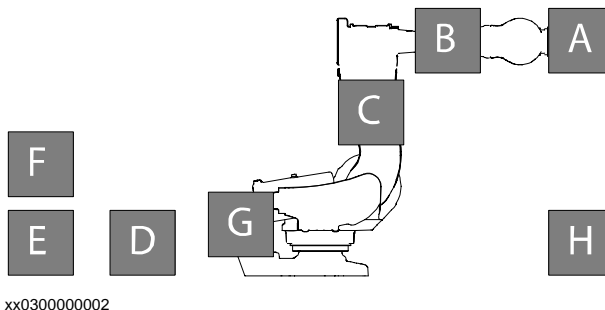

xx030000002

A	Gripper on manipulator (supplied by user)
B	DressPack upper arm
C	DressPack lower arm
D	DressPack floor

E	Robot controller cabinet
F	Power unit
G	Water and air unit
H	Transformer gun fitted on pedestal (supplied by user)

Type Se

This Spot-package is intended for *spot welding applications* where an electrical servo driven transformer gun is fitted onto the turning disk of the manipulator.

The figure shows the configuration of type Se. Its contents are specified in detail in the Product Specification.

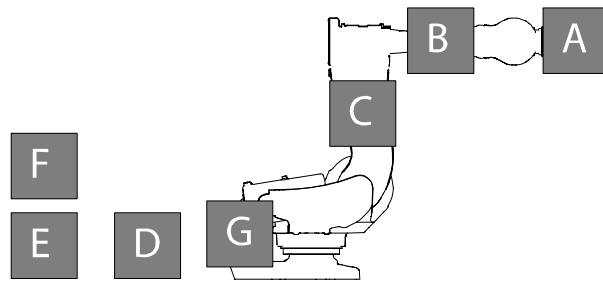

xx0300000001

A	Electrical servo driven transformer gun (supplied by user)
B	DressPack upper arm
C	DressPack lower arm
D	DressPack floor
E	Robot controller cabinet
F	Power unit
G	Water and air unit

Type HSe

This Spot-package is intended for *spot welding applications* where an electrical servo driven transformer gun is fitted onto a separate pedestal. The robot system controls the transformer gun on the pedestal and the manipulator handles the workpiece in a gripper.

The figure shows the configuration of type HSe. Its contents are specified in detail in the Product Specification.

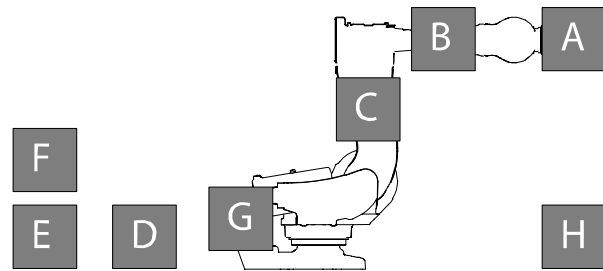

xx0300000002

A	Gripper on manipulator (supplied by user)
B	DressPack upper arm

What is DressPack/SpotPack?

C	DressPack lower arm
D	DressPack floor
E	Robot controller cabinet
F	Power unit
G	Water and air unit
H	Electrical servo driven transformer gun fitted on pedestal (supplied by user)

1 Reference information, SpotPack

1.1. Introduction

General

This chapter includes general information, complementing the more specific information in the *Product manual (part 1 of 2), procedures*.

1 Reference information, SpotPack

1.2. Unit conversion

1.2. Unit conversion

Converter table

Use the table below to convert units used in this manual.

Quantity	Units		
Length	1 m	3.28 ft	39.37 in
Weight	1 kg	2.21 lb	
Pressure	1 bar	100 kPa	14.5 psi
Force	1 N	0.738 lbf	
Moment	1 Nm	0.738 lbf-tn	
Volume	1 L	0.264 US gal	

1.3. Screw joints

General

This section details how to tighten the various types of screw joints on the robot and the controller.

The instructions and torque values are valid for screw joints comprised of metallic materials and do *not* apply to soft or brittle materials.

UNBRAKO screws

UNBRAKO is a special type of screw recommended by ABB for certain screw joints. It features special surface treatment (Gleitmo as described below), and is extremely resistant to fatigue.

Whenever used, this is specified in the instructions, and in such cases, *no other type of replacement screw* is allowed! Using other types of screws will void any warranty and may potentially cause serious damage or injury!

Gleitmo treated screws

Gleitmo is a special surface treatment to reduce the friction when tightening the screw joint. Screws treated with Gleitmo may be reused 3-4 times before the coating disappears. After this the screw must be discarded and replaced with a new one.

When handling screws treated with Gleitmo, protective gloves of nitrile rubber type should be used.

Screws lubricated in other ways

Screws lubricated with Molycote 1000 should *only* be used when specified in the repair, maintenance or installation procedure descriptions.

In such cases, proceed as follows:

1. Apply lubricant to the screw thread.
2. Apply lubricant between the plain washer and screw head.
3. Tighten to the torque specified in section *Tightening torque* below. Screw dimensions of M8 or larger must be tightened with a torque wrench. Screw dimensions of M6 or smaller may be tightened without a torque wrench *if* this is done by trained and qualified personnel.

Lubricant	Art. no.
Molycote 1000 (molybdenum disulphide grease)	1171 2016-618

Tightening torque

Before tightening any screw, note the following:

- Determine whether a standard tightening torque or special torque is to be applied. The standard torques are specified in the tables below. Any special torques are specified in the Repair, Maintenance or Installation procedure description. Any special torque specified overrides the standard value.
- Use the *correct tightening torque* for each type of screw joint.

1 Reference information, SpotPack

1.3. Screw joints

- Only use *correctly calibrated* torque keys.
- Always *tighten the joint by hand*, and never use pneumatical tools.
- Use the *correct tightening technique*, i.e. *do not* jerk. Tighten the screw in a slow, flowing motion.
- Maximum allowed total deviation from the specified value is **10%**!

The table below specifies the recommended standard tightening torque for *oil-lubricated screws with slotted or cross-recess head screws*.

Dimension	Tightening torque (Nm) Class 4.8, oil-lubricated
M2.5	0.25
M3	0.5
M4	1.2
M5	2.5
M6	5.0

The table below specifies the recommended standard tightening torque for *oil-lubricated screws with Allen head screws*.

Dimension	Tightening torque (Nm) Class 8.8, oil-lubricated	Tightening torque (Nm) Class 10.9, oil-lubricated	Tightening torque (Nm) Class 12.9, oil-lubricated
M5	6	-	-
M6	10	-	-
M8	24	34	40
M10	47	67	80
M12	82	115	140
M16	200	290	340

The table below specifies the recommended standard tightening torque for *Molycote-lubricated screws with Allen head screws*.

Dimension	Tightening torque (Nm) Class 10.9, Molycote-lubricated	Tightening torque (Nm) Class 12.9, Molycote-lubricated
M8	28	34
M10	55	66
M12	96	115
M16	235	280

The table below specifies the recommended standard tightening torque for *water and air connectors* when *one* or *both* connectors are made of *brass*.

Dimension	Tightening torque Nm - Nominal	Tightening torque Nm - Min.	Tightening torque Nm - Max.
1/8	12	8	15
1/4	15	10	20
3/8	20	15	25
1/2	40	30	50
3/4	70	55	90

1 Reference information, SpotPack

1.4. Weight specifications

1.4. Weight specifications

Definition

In all repair and maintenance procedures, weights of the components handled are sometimes specified. All components exceeding 22 kg (50 lbs) are high-lighted in this way.

To avoid injury, ABB recommends the use of lifting equipment when handling components with a weight exceeding 22 kg. A wide range of lifting tools and devices are available for each manipulator model.

Example

Below is an example of how a weight specification is presented:



CAUTION!

Caution!

The motor weighs 32 kg! All lifting equipment used must be sized accordingly!

1.5. Toolkits, SpotPack/DressPack

General

All service (repair, maintenance and installation) instructions contain lists of tools required to perform the specified activity. All special tools, i.e. all tools that are not considered standard as defined below, are listed in their instructions respectively.

This way, the tools required are the sum of the Standard Toolkit and any tools listed in the instruction.

Standard toolkit

This standard toolkit contains a set of standard tools used for DressPack/SpotPack, 3HAC 17290-7

Qty	Art. no.	Tool	Remark
1	-	Socket head cap, 5-17mm	-
1	-	Torx socket no: 20-60	-
1	-	Phillips screwdriver, small	For Harting connectors
1	-	Flat screwdriver, medium	For Harting connectors
2	-	Ring-open-end spanner 8-19 mm	For water connectors on water and air unit
1	-	Open end wrench, 27 mm.	For water connectors on DressPack
1	-	Open end wrench, 36 mm	For water connectors on DressPack

Toolkit, retracting unit

This toolkit contains tools needed for retracting unit:

Qty	Art.no.	Tool	Remark
1	-	Hook wrench, (68-75 mm)	For retracting unit

Toolkit, water panel

This toolkit contains tools needed for water panel:

Qty	Art.no.	Tool	Remark
1	-	Socket head cap 4 mm	For water panel
2	-	Ring-open-end spanner, 36 mm	For water panel

1 Reference information, SpotPack

1.5. Toolkits, SpotPack/DressPack

Toolkit, cables

This toolkit contains tools needed for work with cables:

Qty	Art.no	Tool	Remark
1	-	Extraction tool for pins and sockets	
1	-	Stripping pliers	
1	-	Crimping tool	

1.6. Lifting equipment and lifting instructions

General

Many repair and maintenance activities require different pieces of lifting equipment, which are specified in each procedure.

The use of each piece of lifting equipment is *not* detailed in the activity procedure, but in the instruction delivered with each piece of lifting equipment.

This implies that the instructions delivered with the lifting equipment should be stored for later reference.

1 Reference information, SpotPack

1.6. Lifting equipment and lifting instructions

2 Installation

2.1. Introduction

General

This chapter presents general information, complementing the more specific information in the following chapters.

2 Installation

2.2. General installation procedure

2.2. General installation procedure

General

Installing, programming and operating the ABB DressPack/SpotPack product program may be a complex task as each application instance is very specific. The product is designed to fit a wide variety of applications, and must be adapted to each in order to maximize life and function.

The generic installation procedure is detailed below.

Limitation of manipulator movement due to DressPack

When using DressPack upper arm the movements of the robot will be limited.

The position of proc. cable support axis 6 is important to take in consideration when optimizing the possible movements of the robot.

NOTE! Maximum movement of axis 5 is $\pm 110^\circ$.

For more information, please contact Serop Product Support/SEROP/ABB.

E-mail address: serop.product_support@se.abb.com

Effects on armload data and performance

NOTE! The extra weight of the DressPack/SpotPack products will affect the *armload data* and the *performance* of the robot! The effect differs depending on which type of DressPack/SpotPack product.

For more information, please contact Serop Product Support/SEROP/ABB.

E-mail address: serop.product_support@se.abb.com

DressPack, lower arm

This illustration shows the DressPack lower arm attachments and hose package.

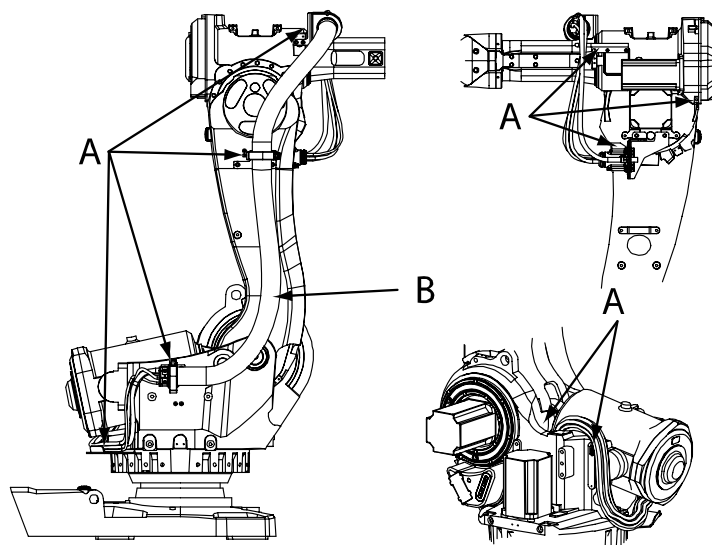

xx0300000083

A	Lower arm proc cable package attachments, various
B	Process cable package

DressPack, upper arm

This illustration shows the DressPack upper arm attachments and hose package.

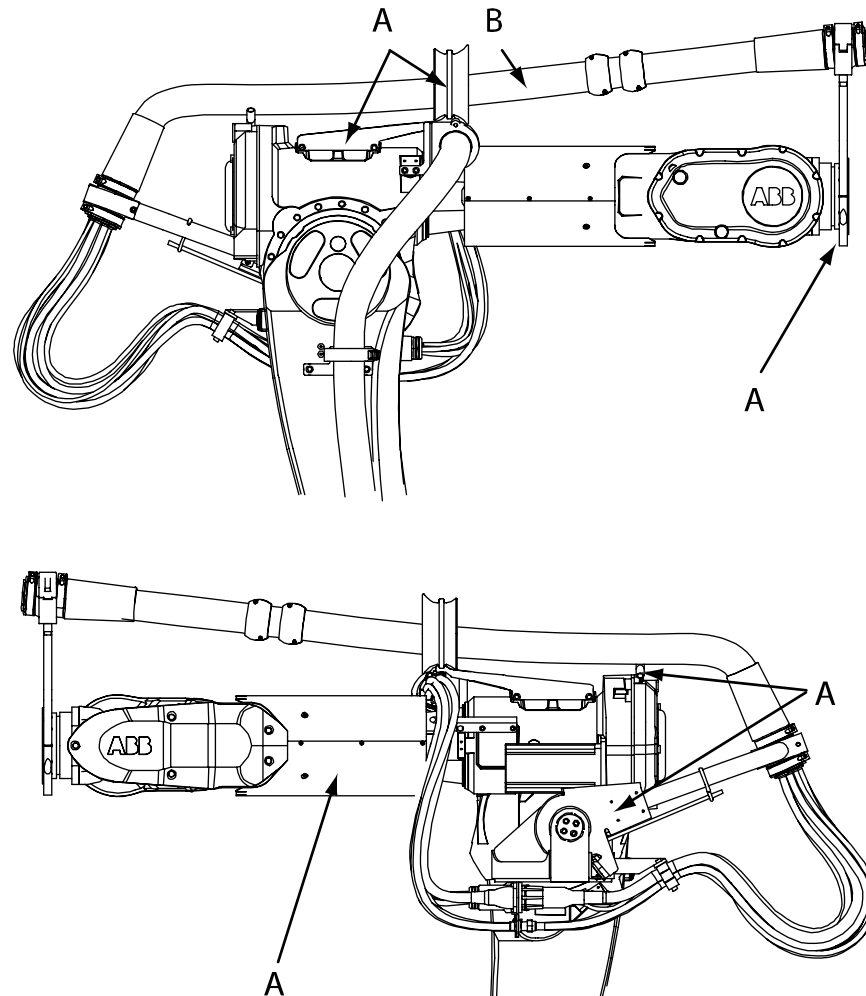

xx030000084

A	Upper arm proc cable package attachments, various
B	Process cable package

Procedure

Step	Action	Info/Illustration
1.	Fit the <i>lower arm proc cable package attachments</i> .	Shown in the figure in section DressPack, lower arm on page 22. The procedure is detailed in section Installation of DressPack lower arm on page 27.
2.	Fit the <i>lower arm process cable package</i> .	Shown in the figure in section DressPack, lower arm on page 22. The procedure is detailed in section Installation of DressPack lower arm on page 27.

2 Installation

2.2. General installation procedure

Step	Action	Info/Illustration
3.	Inspect the lower arm equipment after installation.	Detailed in section Inspection, DressPack lower arm on page 36.
4.	Fit the <i>upper arm proc cable package attachments</i> .	Shown in the figure in section DressPack, upper arm on page 23. The procedure is detailed in section Installation of DressPack upper arm on page 38.
5.	Fit the upper arm <i>process cable package</i> .	Shown in the figure in section DressPack, upper arm on page 23. The procedure is detailed in section Installation of DressPack upper arm on page 38.
6.	Inspect the upper arm equipment after installation.	Detailed in section Inspection, DressPack upper arm on page 45.
7.	Program the manipulator movements while observing the movements of the DressPack equipment at low speed. If any manipulator movements potentially causing abnormal wear and/or breakage of the equipment are discovered, adjust and correct.	Detailed in sections Adjustment of DressPack upper arm on page 50 and Inspection during programming and test-running on page 25.
8.	Run the robot work cycle near full speed while observing the movements of the DressPack equipment at high speed. If any manipulator movements potentially causing abnormal wear and/or breakage of the equipment are discovered, adjust and correct.	
9.	At specified intervals, the DressPack equipment must be maintained as per the maintenance schedule.	Detailed in section Maintenance schedule, SpotPack on page 82.

2.3. Inspection during programming and test-running

General

In order to ensure adequate life of the equipment, it is vital that the cables and hoses are properly installed and operated correctly, with their movement patterns well within the acceptable limits.

Checking the upper arm

This instruction details how to inspect the DressPack upper arm installation **during programming and test-running the complete installation the very first times**.

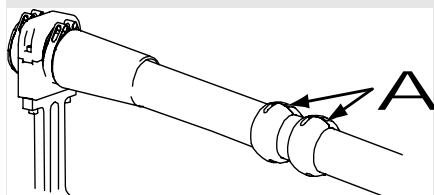
Step	Action	Note/Illustration
1.	Inspect the DressPack upper arm installation before programming and test-running.	Detailed in section Inspection, DressPack upper arm on page 45.
2.	Check the position of the proc cable support, axis 6 in relation to the final movement pattern of the manipulator wrist.	Make a note of where the proc cable support, axis 6 was finally positioned to facilitate replacing it in the future.
3.	Check the positions of the protection sleeves after the programming is completed. Position these where they prevent the protective hose from rubbing against manipulator upper arm as much as possible. If required, additional protective sleeves may be fitted.	 <p>xx0300000221</p> <p>Parts:</p> <ul style="list-style-type: none"> A: Protective sleeves <p>Make a note of where the protective sleeves were finally positioned to facilitate replacing them in the future.</p>
4.	Check the operating cycle of the manipulator, to make sure the movement pattern of the wrist does not cause extensive wear or strain of the cable package.	If required, re-program the manipulator movement pattern!
5.	Large rotating movements of the upper arm (axes 4 and 6 combined) may cause twisting of the DressPack. When programming such movements, we recommend that the rotating movement of axis 6 is ordered before that of axis 4.	This <i>reduces</i> the risk of damaging the DressPack upper arm.
6.	Make sure the upper arm protective hose <i>does not get flattened</i> during rotating upper arm movements.	Flattening <i>increases</i> the risk of damaging the DressPack upper arm.

2 Installation

2.3. Inspection during programming and test-running

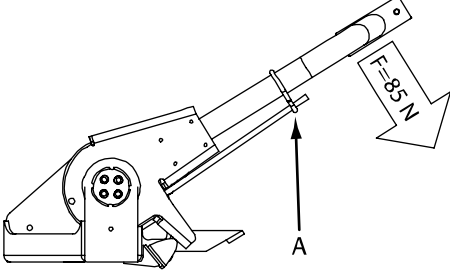
Step	Action	Note/Illustration
7.	Make sure no combined rotating movements of axes 5 and 6 causes collisions between the <i>cables/hoses</i> or the <i>proc cable support, axis 6</i> and the upper arm. Such movements may also cause excessive cable/hose bending.	Collisions and excessive bending <i>increase</i> the risk of damaging the equipment. Minimum bending radius: 10 x cable/hose diameter.
8.	Make sure all retracting unit arm movements are smooth and do not jerk the process cable package.	 <p>xx0300000066</p> <p>If required, increase or reduce the amount of retracting arm spring tension as detailed in section Adjusting the spring tension of the retracting unit on page 120.</p>
9.	IRB 7600 only: Make sure the process cable package does not rub against the sides of the wrist more than absolutely necessary.	The rubbing may result in the cable getting stuck. When the package is released, the retracting unit may snap back potentially causing damage to the equipment.
10.	If any of the actions recommended above, cause you to change the DressPack upper arm installation, it must be reinspected.	Detailed in section Inspection, DressPack upper arm on page 45.

Checking the lower arm

This instruction details how to inspect the DressPack lower arm installation **during programming and test-running the complete installation the very first times**.

Step	Action	Info/Illustration
1.	Inspect the DressPack lower arm installation before programming and test-running.	Detailed in section Inspection, DressPack lower arm on page 36.
2.	Check the operating cycle of the manipulator, to make sure the movement pattern of the manipulator does not cause extensive wear or straining on the cable package.	If required, re-program the manipulator movement pattern!
3.	If any of the actions recommended above, causes changes of the DressPack lower arm installation, it must be reinspected.	Detailed in section Inspection, DressPack lower arm on page 36.

2.4 DressPack lower arm

2.4.1. Installation of DressPack lower arm

Location of DressPack lower arm

The DressPack lower arm is located as shown in the figure below.

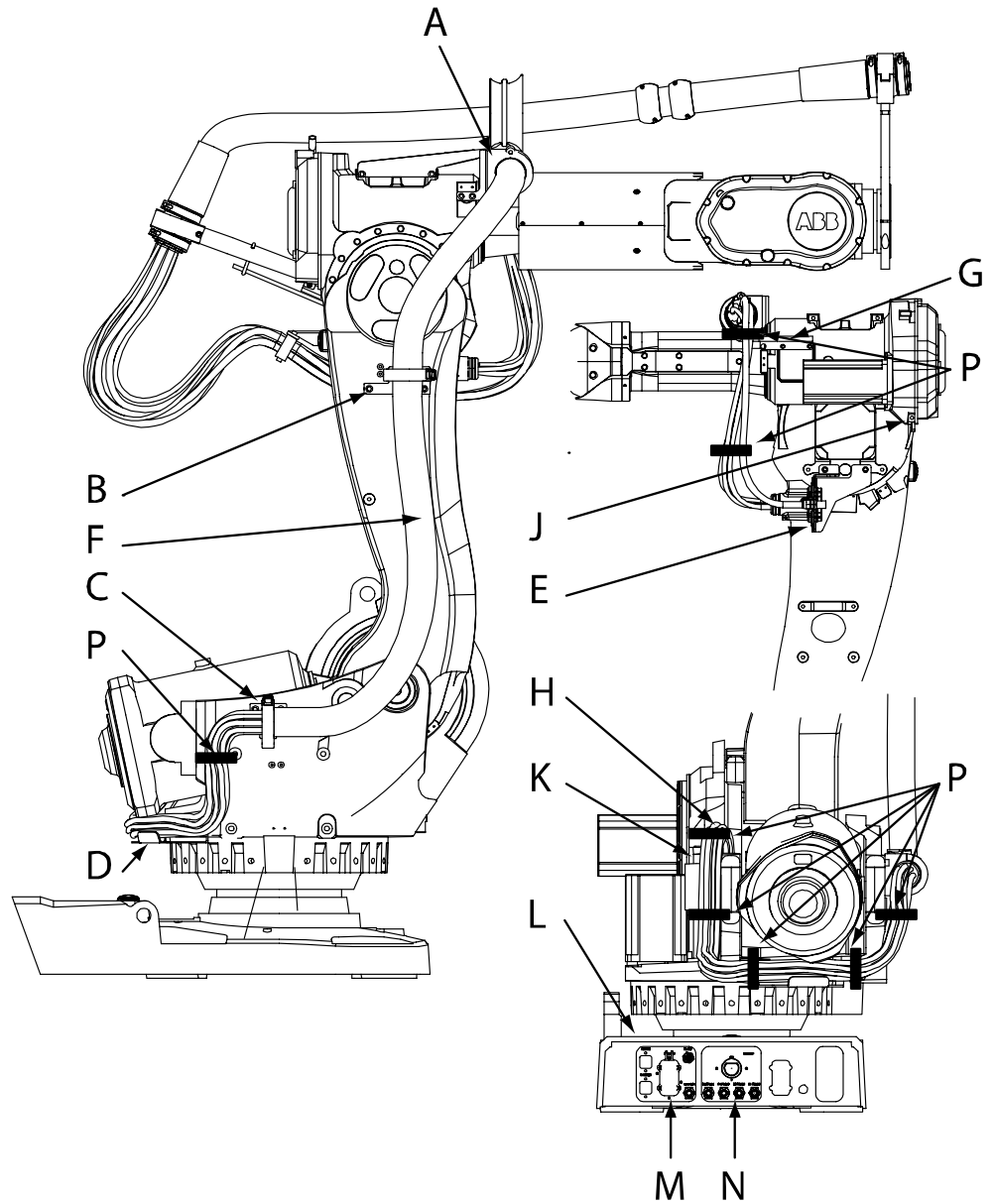

xx0300000006

A	Upper proc cable package attachment
B	Mid proc cable package attachment
C	Lower proc cable package attachment
D	Cable conduit
E	Connection plate ax3, proc.

2 Installation

2.4.1. Installation of DressPack lower arm

F	Process cable package
G	Cable guide
H	Process cable package attachment at gearbox 1
J	Attachment point below gearbox 4
K	Cable fixing bracket
L	Plate, base (top cover)
M	Plate, customer
N	Plate, proc.
P	Velcro straps (7 pcs)

Required equipment

Equipment, etc.	Spare part no.	Art. no.	Note
DressPack lower arm		See the Spare parts section!	A number of versions are available.
Locking liquid		3HAB 7116-1	For locking the gripping clamp screws
Standard toolkit, DressPack/SpotPack		3HAC 17290-7	The contents are defined in section Standard toolkit!
Other tools and procedures may be required. See references to these procedures in the step-by-step instructions below.			These procedures include references to the tools required.
Circuit Diagram		3HAC 17669-2	DressPack for IRB 6600, 6650 and 7600 using <i>pneumatic</i> welding gun
Circuit Diagram		3HAC 17669-1	DressPack for IRB 6600, 6650 and 7600 using <i>servo</i> welding gun

DressPack lower arm, cable clamp attachment sets.

When ordered as spare parts, the cable clamp attachments for the process cable package, are delivered as sets. There are three different cable clamp attachment sets - upper, middle and lower. For details see Spare parts!

Installation, DressPack lower arm attachments

The procedure below details how to install the attachments of DressPack lower arm. It does not deal with details specific to each version, such as article numbers, etc. Such details are specified in the Spare Parts section.

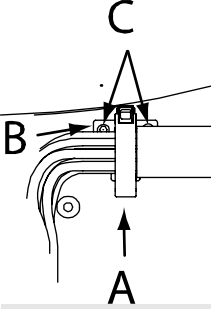
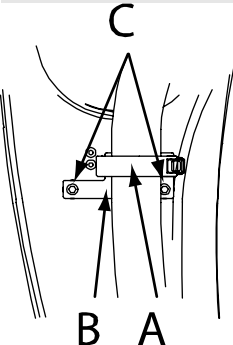
Step	Action	Note/Illustration
1.	<p>Fit the gripping clamp to the metal bracket of the <i>Lower proc cable package attachment</i>.</p> <p>Lock the screws with <i>locking liquid</i>.</p> <p>The screws are supplied with the kit.</p>	<p>Shown in the figure in section Location of DressPack lower arm on page 27.</p> <p>The article number of locking liquid is specified in section Required equipment on page 28.</p>  <p>xx0300000132</p> <p>Parts:</p> <ul style="list-style-type: none"> • A: Plastic cable clamp • B: Metal bracket • C: Metal bracket attachment screws <p>Screw dimension: M8x16</p>
2.	<p>Fit the gripping clamp to the metal bracket of the <i>Mid proc cable package attachment</i>.</p> <p>The screws are supplied with the kit.</p>	<p>Shown in the figure in section Location of DressPack lower arm on page 27.</p>  <p>xx0300000131</p> <p>Parts:</p> <ul style="list-style-type: none"> • A: Plastic cable clamp • B: Metal bracket • C: Metal bracket attachment screws <p>Screw dimension: M8x16</p>

2 Installation

2.4.1. Installation of DressPack lower arm

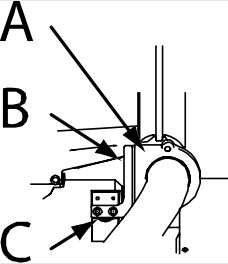
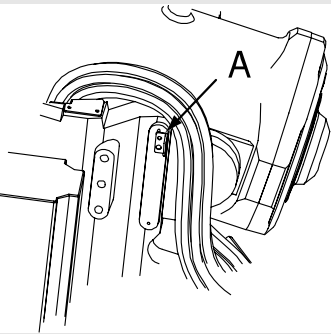
Step	Action	Note/Illustration
3.	<p>Fit the gripping clamp to the metal bracket of the <i>Upper proc cable package attachment</i>. The screws are supplied with the kit.</p>	<p>Shown in the figure in section Location of DressPack lower arm on page 27.</p>  <p>xx030000114</p> <p>Parts:</p> <ul style="list-style-type: none"> • A: Plastic cable clamp • B: Metal bracket • C: Metal bracket attachment screws <p>Screw dimension: M8x16</p>
4.	<p>Fit the completed proc cable package attachments to the manipulator. The screws are supplied with the kit.</p>	<p>Screw dimension, upper attachment: M10x16 Screw dimension, lower and mid attachments: M12x25</p>
5.	<p>Fit the <i>cable conduit</i> to the manipulator frame with two Torx screws. The screws are supplied with the kit.</p>	<p>Shown in the figure in section Location of DressPack lower arm on page 27. Screw dimension: M6x16</p>
6.	<p>Fit the <i>cable fixing bracket</i> to the manipulator frame and secure with one Torx screw. The screw is supplied with the kit.</p>	 <p>xx030000133</p> <p>Parts:</p> <ul style="list-style-type: none"> • A: Cable fixing bracket <p>Screw dimension: M6x16</p>
7.	<p>Fit the <i>cable guide</i> by first removing the original cover attachment screws. Use the longer attachment screws supplied in the kit to secure the cable guide. Lock the screws with <i>locking liquid</i>.</p>	<p>Shown in the figure in section Location of DressPack lower arm on page 27. Tightening torque: 24 Nm \pm 3 Nm Screw dimension: M8x25 The article number is specified in section Required equipment on page 28.</p>

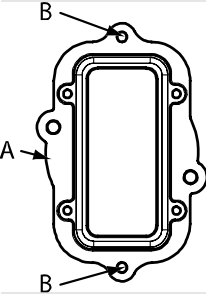
Step	Action	Note/Illustration
8.	Fit the <i>connection plate ax 3</i> . Secure with two Allen head screws to the original connector holder beneath motor 3 <i>and</i> an additional support fitted to the <i>attachment point below gearbox 4</i> . The screws are supplied with the kit.	Shown in the figure in section Location of DressPack lower arm on page 27. Screw dimension: M10x16
9.	Fit the adapter complete, to the connection plate ax 3 with two attachment screws. The adapter complete, shall be fitted on the front side of the connection plate ax 3. The screws are supplied with the kit.	 <p>xx0300000195</p> Parts: <ul style="list-style-type: none"> • A: Adapter complete • B: Attachment screws Screw dimension: M6x16
10	Remove the <i>plate, base</i> by unscrewing its attachment screws.	Shown in the figure in section Location of DressPack lower arm on page 27.

2 Installation

2.4.1. Installation of DressPack lower arm

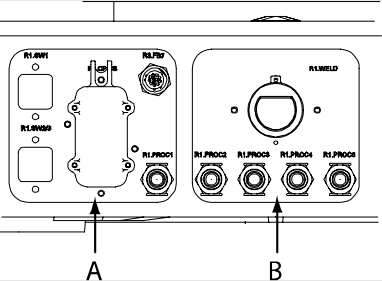
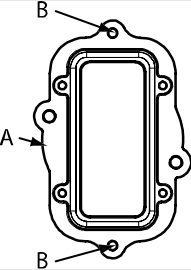
Step	Action	Note/Illustration
11.	<p>The kit contains plates depending on the intended application:</p> <ul style="list-style-type: none"> Spot welding applications (SW) includes <i>plates A and B!</i> Material handling applications (MH) include <i>plate A only!</i> <p>Remove the blank cover plates and replace them with the <i>plate customer and plate proc.</i> as specified above.</p> <p>The screws are supplied with the kit.</p>	<p>Shown in the figure in section Location of DressPack lower arm on page 27.</p>  <p>xx0300000058</p> <p>Parts:</p> <ul style="list-style-type: none"> A: Plate customer B: Plate, proc. <p>Screw dimension: M6x16</p>
12.	<p>Fit the adapter complete to the plate customer with two attachment screws.</p> <p>The adapter complete, shall be fitted on the back side of the plate customer.</p> <p>The screws are supplied with the kit.</p>	 <p>xx0300000195</p> <p>Parts:</p> <ul style="list-style-type: none"> A: Adapter complete B: Attachment screws <p>Screw dimension: M6x16</p>

Installation, DressPack lower arm process cable package

The procedure below details how to install the process cable package (called package) of DressPack lower arm. It does not deal with details specific to each version, such as article numbers, connector types, etc. Such details are specified in the Spare Parts section.



CAUTION!

The cable packs are sensitive to mechanical damage! They must be handled with care, especially the connectors, in order to avoid damaging them!

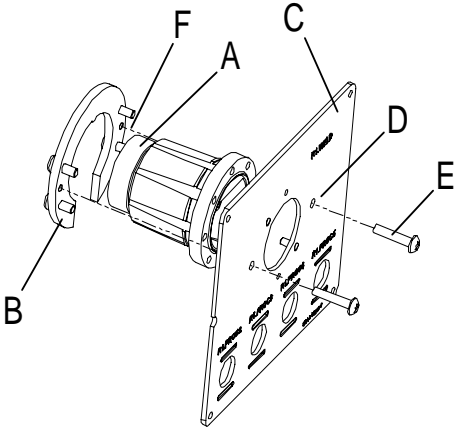
Step	Action	Info/Illustration
1.	Straighten the package out on the floor.	
2.	<p>Pull the lower end of the package down through the hole in gearbox, axis 1:</p> <ul style="list-style-type: none"> the signal cable/hose package weld power cable (slightly to the right of the signal cable/hose package to facilitate connecting the cables in the manipulator base). <p>Make sure no cables or hoses are strained or twisted.</p>	<p><i>Do not secure the cables/hoses yet!</i></p>
3.	<p>Spot Welding applications only:</p> <p>Fit the weld power cable to the rear of the plate customer, with two attachment screws using the weld connector bracket. Do not tighten the attachment screws at this point, until after docking the signal cable/hose package connectors. The screws are supplied with the kit.</p>	 <p>xx0300000196</p> <p>Parts (as seen from above):</p> <ul style="list-style-type: none"> A: Weld power cable (behind Plate customer) B: Weld connector bracket C: Plate customer D: Screw holes in plate customer E: Attachment screws F: Guide pins on weld connector bracket <p>Screw dimension: M6x30</p>
4.	<p>Fit the connectors to the <i>plate customer and plate, proc.</i> previously fitted to the <i>connection plate, base</i>. The screws are supplied with the kit.</p>	<p>Shown in the figure in section Location of DressPack lower arm on page 27. Recheck all cables and hoses for straining or twisting. Reroute if required! Screw dimension: M6x20</p>
5.	<p>In order to get the weld power cable mounted in the right position on the plate customer, first connect the floor weld cable to the weld power cable and use it as a guide. Before tightening the weld power attachment screws, make sure that the cable connector is evenly positioned in the hole of the plate customer. Tighten the weld power cable attachment screws.</p>	<p>The weld power attachments screws are shown in figure above!</p>

2 Installation

2.4.1. Installation of DressPack lower arm

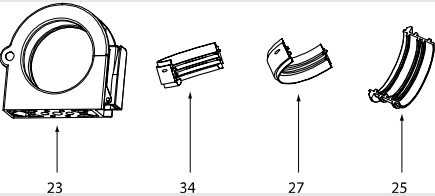
Step	Action	Info/Illustration
6.	Secure the signal cable/hose package in the hole in gearbox, axis 1. Consequently secure the weld power cable to the previously fitted package. The screws are supplied with the kit.	Screw dimension: M6x16 Locking nut dimension: M6
7.	Secure the lower end of the protective hose to the <i>lower proc cable package attachment</i> and tighten the cable clamp.	<p>The illustration below shows all proc cable package attachment parts. The combination of parts differs and depends on attachment in question. For details see DressPack lower arm, cable clamp attachments on page 169!</p>  <p>xx0300000124</p> <p>The lower end attachment is shown in the figure in section Location of DressPack lower arm on page 27.</p>
8.	Secure the middle end of the protective hose to the <i>mid proc cable package attachment</i> . <ul style="list-style-type: none"> IRB 6600:green band on the protective hose IRB 7600:white band on the protective hose <p>Make sure the hose is in a position that enables the clamp to fully cover the color band.</p> <p>The position of the color markings are shown in the Foldout section.</p> <p>Tighten the cable clamp, making sure the protective hose is locked vertically, but still able to swivel slightly.</p> <p>Note! IRB 6650S uses two middle end attachments: middle front and middle back.</p>	<p>The illustration above shows all proc cable package attachment parts. The combination of parts differs and depends on attachment in question. For details see DressPack lower arm, cable clamp attachments on page 169!</p> <p>The middle end attachment is shown in the figure in section Location of DressPack lower arm on page 27.</p>
9.	Secure the upper end of the protective hose to the <i>upper proc cable package attachment</i> with the cable clamp. Make sure the clamp squarely secures the package and the rubber cable retainer. Failure to do so will substantially increase the risk of damaging the package!	<p>The illustration above shows all proc cable package attachment parts. The combination of parts differs and depends on attachment in question. For details see DressPack lower arm, cable clamp attachments on page 169!</p> <p>The upper end attachment is shown in the figure in section Location of DressPack lower arm on page 27.</p>

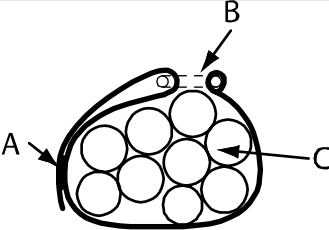
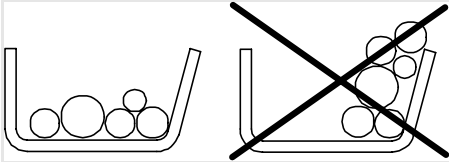
Step	Action	Info/Illustration
10	Route the upper end of the package over the <i>cable guide</i> to the <i>connection plate ax3, proc</i> and fit all connectors in accordance with their respective marking. The screws are supplied with the kit.	Shown in the figure in section Location of DressPack lower arm on page 27. Screw dimension: M6x20
11.	Use the <i>seven Velcro straps</i> supplied in the kit to secure the cables/hoses.	<p>Shown in the figure in section Location of DressPack lower arm on page 27. How to use the Velcro straps:</p>  <p>xx0300000135</p> <p>Parts:</p> <ul style="list-style-type: none"> • A: Velcro contact point • B: Strap buckle • C: Cross-section of the cables to be secured <p>Stack the cables as low as possible in the cable conduit!</p>  <p>xx0300000136</p>
12	Inspect the DressPack lower arm installation.	Detailed in section Inspection, DressPack lower arm on page 36.

2 Installation

2.4.2. Inspection, DressPack lower arm

2.4.2. Inspection, DressPack lower arm

General

In order to ensure adequate life of the equipment, it is vital that the cables and hoses are properly installed and operated correctly, with their movement patterns well within the acceptable limits.

This instruction details how to inspect the DressPack lower arm installation in this regard.

Procedure, general

Step	Action	Info/Illustration
1.	Inspect the Process cable package.	Detailed in section Procedure, Process cable package on page 36.
2.	Inspect all attachments, brackets and any other hardware securing or guiding the protective hose.	Detailed in section Procedure, attachments and brackets on page 37.

Procedure, Process cable package

This section details each inspection to be carried out, not necessarily in any particular order unless stated.

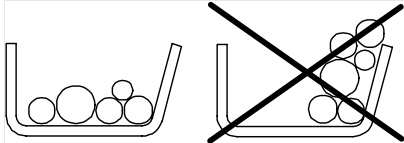
Step	Action	Info/Illustration
1.	<i>Do not bend</i> any cable or hose excessively! Also, make sure no cable or hose is twisted.	Minimum bending radius is approximately 10 x the cable or hose diameter.
2.	Make sure all cables straps are tight enough to prevent the cable package from moving in any undesired way.	
3.	Make sure the cable package is properly connected at connection plate, axis 3 on the rear of the upper arm as well as at the manipulator base.	
4.	Make sure no hoses or cables, or parts thereof, touch any part of the manipulator structure in a way that may cause wear.	
5.	Make sure all cables and hoses move smoothly together during operation and that no part of the cable package moves in a different pattern.	
6.	Make sure that all cables and hoses are stacked in the cable conduit as low as possible.	Shown in figure below:  xx0300000136

Step	Action	Info/Illustration
7.	Make sure that cables, hoses or packages do not rub against <i>any sharp corner of anything</i> (not just the manipulator itself)!	
8.	Make sure all connection points are well tightened and sealed in order to avoid leaks.	

Procedure, attachments and brackets

This section details each inspection to be carried out, not necessarily in any particular order unless stated.

Step	Action	Info/Illustration
1.	Recheck all cable clamps securing the process cable package and protective hose for tightness.	Tightening torques are specified in: <ul style="list-style-type: none">• standard tightening torque table (standard tightening torques)• Installation chapter (non-standard tightening torques)

2 Installation

2.5.1. Installation of DressPack upper arm

2.5 DressPack upper arm

2.5.1. Installation of DressPack upper arm

Location of DressPack upper arm

The DressPack upper arm is located as shown in the figure below.

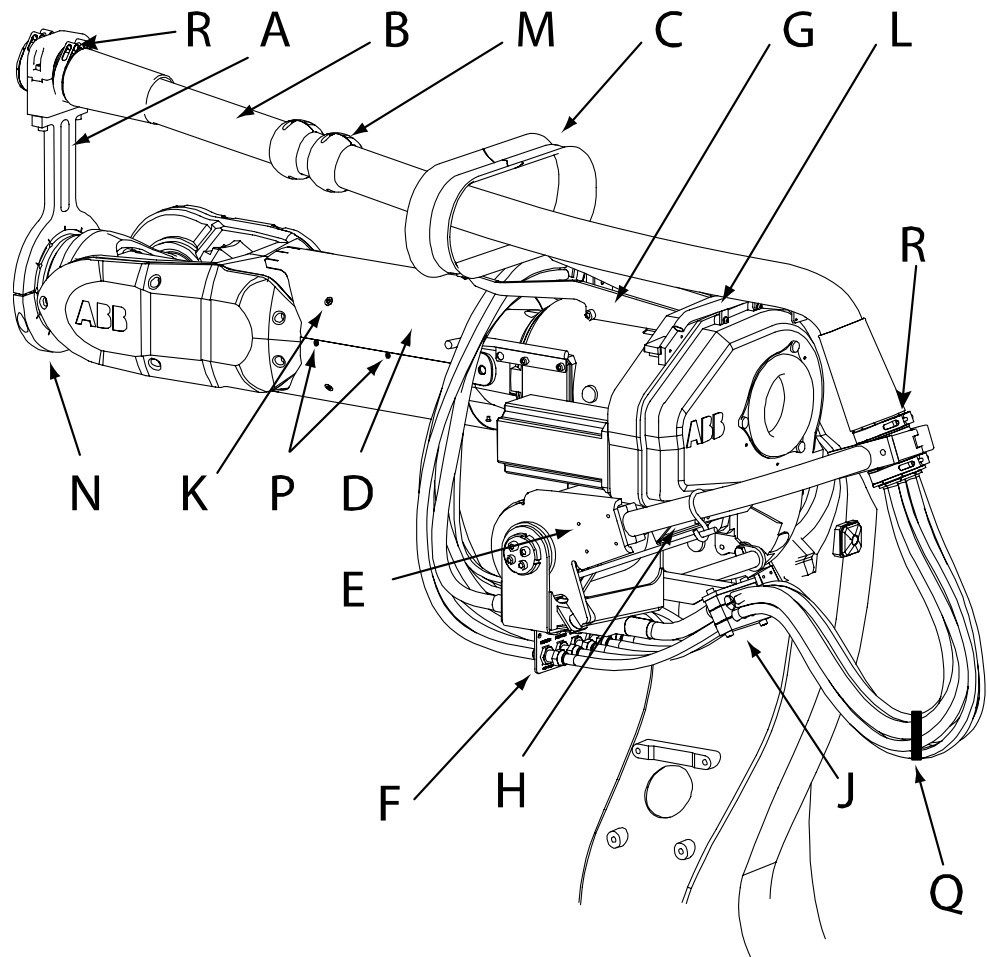

xx030000004

A	Proc cable support, axis 6
B	Hose package
C	Hose support
D	Arm protection, two halves
E	Retracting unit
F	Connection plate, axis 3, proc
G	Brackets for hose support
H	Attachment point below gearbox 4
J	Cable retainer
K	Arm protection attachment screws
L	Rear hose support

M	Protection sleeves
N	Lower half of proc cable support, axis 6
P	Screws securing the arm protection halves to each other
Q	Velcro straps
R	Slide sleeves

Required equipment

Equipment	Spare part no.	Art. no.	Note
DressPack upper arm		See the Spare parts section!	A number of versions are available.
Standard toolkit, DressPack/ SpotPack		3HAC 17290-7	The contents are defined in section Standard toolkit!
Other tools and procedures may be required. See references to these procedures in the step-by-step instructions below.			These procedures include references to the tools required.
Circuit Diagram		3HAC 17669-2	DressPack for IRB 6600, 6650 and 7600 using <i>pneumatic</i> welding gun
Circuit Diagram		3HAC 17669-1	DressPack for IRB 6600, 6650 and 7600 using <i>servo</i> welding gun

Installation, DressPack upper arm attachments

The procedure below details how to install the attachments of DressPack upper arm. It does not deal with details specific to each version, such as article numbers, connector types, etc. Such details are specified in the Spare Parts section.



DANGER!

The retracting unit weighs 36 kg! Use a suitable lifting device to avoid injury to personnel!

Step	Action	Note/Illustration
1.	Fit the Dresspack lower arm.	Detailed in section Installation of DressPack lower arm on page 27.
2.	Remove the support from the connection plate axis 3 previously mounted at <i>attachment point below gearbox 4</i> .	Shown in the figure in section Location of DressPack upper arm on page 38.

2 Installation

2.5.1. Installation of DressPack upper arm

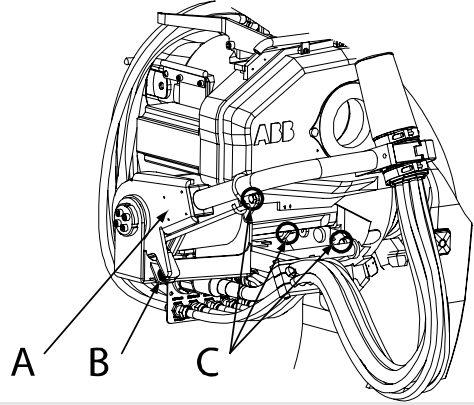
Step	Action	Note/Illustration
3.	Lift the <i>retracting unit</i> and fit it. Secure it with three Allen head screws.	 <p>xx0300000055</p> <p>Parts:</p> <ul style="list-style-type: none"> • A: Retracting unit • B: Damper • C: Retracting unit attachment screws (3 pcs) <p>Screw dimension: M12x25</p>
4.	Is the manipulator fitted with a UL lamp? This is an operational indication lamp fitted to the upper arm. If a <i>UL lamp</i> is fitted, it will need to be moved before proceeding below. The procedure is detailed in section Relocating the UL lamp on page 43. If <i>no UL lamp</i> is fitted, please proceed below.	
5.	Fit the rear hose support and secure it with two Torx screws supplied in the kit.	Shown in the figure in section Location of DressPack upper arm on page 38. Screw dimension: M6x16
6.	Secure the <i>hose support</i> to its two <i>brackets for hose support</i> with two Torx screws without tightening the screws fully.	Shown in the figure in section Location of DressPack upper arm on page 38. Screw dimension: M6x20
7.	Fit the complete hose support assembly with four Allen head screws supplied in the kit. Tighten all screws after fitting.	Shown in the figure in section Location of DressPack upper arm on page 38. Screw dimension: M12x25
8.	Fit the two <i>upper arm protection</i> halves with the M8 screws. Secure them to each other with the M5 screws. Make sure no sharp edges or screws risk damaging any cables/hoses touching the upper arm protection.	Shown in the figure in section Location of DressPack upper arm on page 38. Screw dimension for <i>attaching</i> the protection halves: M8x16. Screw dimension for <i>securing</i> the protection halves: M5x6 (counter sunk). The halves are not identical and are designed to fit one way only. If the fit is not perfect or if the protection halves interfere with the upper arm, they may have been switched.

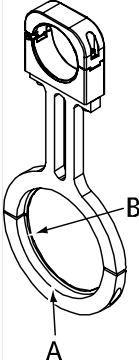
Step	Action	Note/Illustration
9.	<p>Install the <i>proc cable support, axis 6</i>:</p> <ul style="list-style-type: none"> • separate the lower half from the proc cable support axis 6 • fit them "behind" the manipulator turning disk. Make sure the support is turned the right way! • pull the assembly forwards until it is seated against the rear of the turning disk 	<p>Shown in the figure in section Location of DressPack upper arm on page 38. Screw dimension: M12x35</p>  <p>xx0300000137</p> <p>Parts:</p> <ul style="list-style-type: none"> • A: lower half of the proc cable support axis 6 • B: Cut-out must face forwards, i.e. towards the manipulator turning disk!
10	Check the position of the proc cable support, axis 6.	<p>A suitable baseline position is approximately vertical above the manipulator upper arm with the manipulator in the calibration position.</p> <p>This position will later require adjusting to optimize the life and performance of the equipment.</p>
11.	Tighten the two screws making sure there are equal gaps between upper and lower half of the proc cable support axis 6 on both sides.	

Installation, DressPack upper arm process cable package

The procedure below details how to install the process cable package (called package) of DressPack upper arm. It does not deal with details specific to each version, such as article numbers, connector types, etc. Such details are specified in the Spare Parts section.

2 Installation

2.5.1. Installation of DressPack upper arm



CAUTION!

The cable packs are sensitive to mechanical damage! They must be handled with care, especially the connectors, in order to avoid damaging them!

Step	Action	Info/Illustration
1.	Straighten the package out and route it through the hose support on top of the upper arm.	
2.	Fit the rear end of the package to the cable clamp on the <i>retracting unit</i> . Rotate the package in the clamp to achieve a smooth bend in the package. The screws of the clamps shall have a upward position.	Shown in the figure in section Location of DressPack upper arm on page 38. Do not pull the cables/hoses backwards towards the retracting unit. Doing so may add tension to the connectors at <i>connection plate ax3</i> .
3.	Fit the <i>cable retainer</i> with the screws delivered with the kit.	Shown in the figure in section Location of DressPack upper arm on page 38. Screw dimensions: M8x16
4.	Make sure the cable loop from the retracting unit cable clamp to the cable retainer does not twist or bend cables or hoses. If they are twisted or bent, rotate the complete package in the retracting unit clamp.	Keep in mind that all cable/hose movements become exaggerated during full speed operation!
5.	Secure the front end of the protective hose to the <i>proc cable support, axis 6</i> at the turning disk and tighten the cable clamp. Make sure the protective hose is not turned 360° in relation to the movement pattern.	Shown in the figure in section Location of DressPack upper arm on page 38.
6.	Check the length of the protruding cables/hoses to ensure that they may be routed to the tool in a smooth bend while being secured with cable ties or similar. Make sure the cables/hoses are not excessively bent in the secured position.	Minimum bending radius: 10 x cable/hose diameter Keep in mind that all cable/hose movements become exaggerated during full speed operation! When securing the cables/hoses with cable ties, <i>do not use too narrow ties</i> or pull too tight, since this may damage the cable/hose. Remember that switching the weld power as well as the water ON and OFF may cause the cables/hoses to move slightly, which may require additional clamping to avoid damage caused by these movements.
7.	Connect all electrical/water/air connectors to the connectors on <i>connection plate axis 3</i> .	Shown in the figure in section Location of DressPack upper arm on page 38. All connectors are marked with their designations respectively.

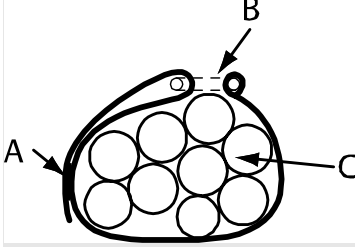
Step	Action	Info/Illustration
8.	Use the Velcro strap supplied in the kit to secure the cables/hoses. Make sure no cables/hoses hang freely in a way that may cause them to obstruct the manipulator movements or cause wear.	<p>Shown in the figure in section Location of DressPack upper arm on page 38. How to use the Velcro straps:</p>  <p>xx0300000135</p> <p>Parts:</p> <ul style="list-style-type: none"> • A: Velcro contact point • B: Strap buckle • C: Cross-section of the cables to be secured <p>Keep in mind that all cable/hose movements become exaggerated during full speed operation which may increase the strain on connectors!</p>
9.	Inspect the DressPack upper arm installation.	Detailed in section Inspection, DressPack upper arm on page 45.
10	After programming the manipulator movements, the position of the two protection sleeves must be adjusted. This will minimize the protective hose rubbing against the manipulator upper arm.	Shown in the figure in section Location of DressPack upper arm on page 38.
11.	Cut the hoses to the correct length, fit nipples and connect them to the gun on the wrist or corresponding.	When cutting the hoses, <i>do not</i> cut them too short! Remember that replacing an individual hose may require cutting the hose to remove the nipple!

Relocating the UL lamp

Manipulators fitted with an UL lamp will need to have the lamp relocated since it would otherwise interfere with the DressPack upper arm during operation.

2 Installation

2.5.1. Installation of DressPack upper arm

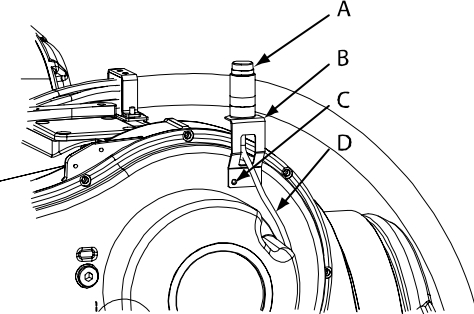
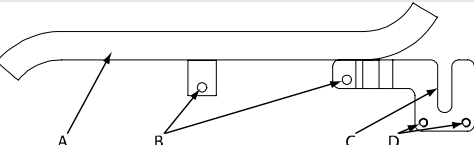
Step	Action	Info/Illustration
1.	Remove the UL lamp by unscrewing its two attachment screws.	<p>The illustration shows the UL lamp fitted to an IRB 7600, but the principle is the same as for an IRB 6600.</p>  <p>xx0300000138</p> <p>Parts:</p> <ul style="list-style-type: none"> • A: UL lamp • B: UL lamp attachment • C: Attachment screws • D: UL lamp cable
2.	Secure the UL lamp to the rear hose support and secure it with the screws removed in the previous step.	 <p>xx0300000139</p> <p>Parts:</p> <ul style="list-style-type: none"> • A: Rear hose support • B: Rear hose support attachment screws and washers • C: UL lamp mounting position • D: UL lamp attachment screws <p>Screw dimensions: original UL lamp attachment screws</p>
3.	Fit the complete rear hose support assembly to the rear of gearbox using the <i>Rear hose support attachment screws</i> .	<p>Shown in the figure above!</p> <p>Screw dimensions: M6x16 and washers</p>
4.	Check the UL lamp cable to make sure its length is sufficient. In some cases, the cable will need to be cut loose from the harness and pulled backwards slightly. After pulling the cable backwards, restrap the harness with cable ties.	<p>When securing the cables/hoses with cable ties, <i>do not use too narrow ties</i> or pull too tight, since this may damage the cable/hose.</p>

2.5.2. Inspection, DressPack upper arm

General

In order to ensure adequate life of the equipment, it is vital that the cables and hoses are properly installed and operated correctly, with their movement patterns well within the acceptable limits.

This instruction details how to inspect the DressPack upper arm installation in this regard.

2 Installation

2.5.2. Inspection, DressPack upper arm

Procedure, general

Step	Action	Info/Illustration
1.	Inspect all attachments, brackets and any other hardware securing or guiding the protective hose.	Detailed in section <i>Attachments and brackets</i> on page 46.
2.	Inspect the process cable package.	Detailed in section <i>Cables and hoses</i> on page 47.
3.	Make sure all cables and hoses are securely fixed and connected.	Detailed in section <i>Securing and connecting</i> on page 48.

Attachments and brackets

This section details each inspection to be carried out, not necessarily in any particular order unless stated.

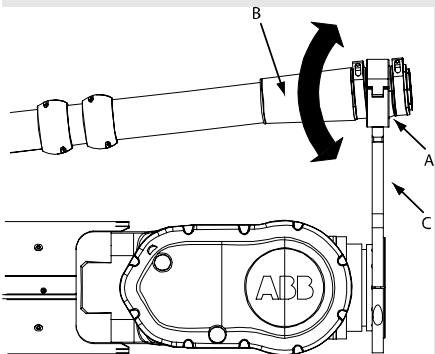
Step	Action	Info/Illustration
1.	Make sure the sliding surfaces of the slide sleeve have not been damaged. Check this with normal hand force: grab hold of the package and pull and turn to make sure that the package is free to slide.	 <p>xx0300000199</p> <ul style="list-style-type: none">• A: Slide sleeve side surface• B: Hose reinforcement• C: Proc cable support axis 6 <p>A damaged surface may potentially prevent the cable package from rotating causing excessive wear.</p>

Step	Action	Info/Illustration
2.	Check that the proc cable support axis 6 is pushed forward completely against the turning disc axis 6. See illustration!	<p>xx0400001040</p> <p>Parts:</p> <ul style="list-style-type: none"> • A: Proc cable support axis 6 • B: Turning disc axis 6
3.	Check the angle of the <i>proc cable support, axis 6</i> in relation to the movement pattern of the cable package. If required, change the position of the proc cable support, axis 6, to ensure that the cable package does not get stretched or bent excessively.	<p>xx0400001002</p> <ul style="list-style-type: none"> • A: Never shorter than 400 mm!

Cables and hoses

This section details each inspection to be carried out, not necessarily in any particular order if not so stated.

Step	Action	Info/Illustration
1.	<i>Do not bend</i> any cable or hose excessively! Also make sure no cable or hose is twisted.	Minimum bending radius is approximately 10 x the cable or hose diameter.
2.	Make sure that all hoses and cables to gun or gripper are long enough to avoid stretching during any part of the cycle. When cutting the cables/hoses, make sure the length is sufficient to enable rotating the proc cable support, axis 6 as detailed above!	Never shorter than 400 mm.
3.	Make sure that cables are clamped with straps in a way that there is no movement at connectors.	

2 Installation

2.5.2. Inspection, DressPack upper arm

Step	Action	Info/Illustration
4.	Make sure that no hoses or cables, or parts thereof, touch any part of the <i>manipulator structure</i> in a way that may cause wear.	
5.	Make sure that no hoses or cables, or parts thereof, touch any part of the <i>surrounding equipment</i> in a way that may cause wear.	
6.	Make sure all cables and hoses move smoothly together during operation and that no part of the cable package moves in a different pattern.	
7.	Make sure cable loops are not allowed to swing as the manipulator runs.	

Securing and connecting

This section details each inspection to be carried out, not necessarily in any particular order unless stated.

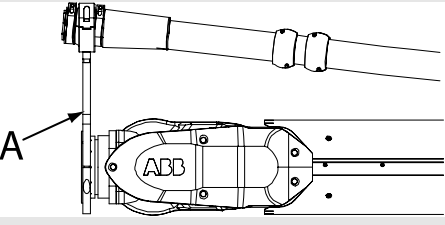
Step	Action	Info/Illustration
1.	Recheck all cable clamps securing the process cable package and protective hose for tightness.	Tightening torques are specified in: <ul style="list-style-type: none"> standard tightening torque table (standard tightening torques) Installation chapter (non-standard tightening torques)
2.	Make sure all cables straps are tight enough to prevent the cable package from moving in any undesired way. The cable ties should not be too narrow. This may damage the cables/hoses.	
3.	<i>Do not strap</i> , or in any other way secure, the cables/hoses to the proc cable support, axis 6 in a way that may prevent the assembly to swivel properly. Whenever strapping the cables/hoses to the proc cable support, axis 6, make sure the assembly is free to swivel properly.	 <p>xx0300000072</p> <ul style="list-style-type: none"> A: Proc cable support, axis 6
4.	When securing cables and hoses with cable ties: <i>never</i> overtighten the ties! This may damage the equipment.	
5.	Make sure that the cable package have been properly connected at connection plate, axis 3 on the rear of the upper arm as well as at the tool on the manipulator turning disk.	

Step	Action	Info/Illustration
6.	Make sure all connection points are well tightened and sealed in order to avoid leaks.	
7.	Make sure the weight of the cable package is secured to the tool in order to avoid straining the connectors!	

2 Installation

2.5.3.1. Adjustment of DressPack upper arm

2.5.3. Adjustments

2.5.3.1. Adjustment of DressPack upper arm

General

The instructions below detail how to adjust the routing of the DressPack upper arm to avoid reducing its life.

Hose reinforcement

Should the hose reinforcement get strained under the upper arm during the work cycle, the following tips may assist in alleviating the problem.

The illustration below shows a DressPack upper arm fitted to an IRB 6400R, but the problem is identical to all manipulator types.

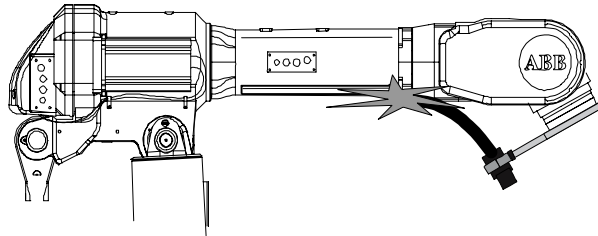

xx0300000167

Step	Action	Note/Illustration
1.	Try changing the manipulator position or orientation at the particular position to reduce the angle of axis 5 in combination of axis 6.	
2.	OR Rotate the attachment angle of the proc cable support, axis 6 slightly.	

Hoses and cables too long around the wrist

If the DressPack upper arm is too long, the hose loop may get obstructed or caught by the brackets or any other equipment.

The illustration below shows a DressPack upper arm fitted to an IRB 6400R, but the problem is identical to all manipulator types.

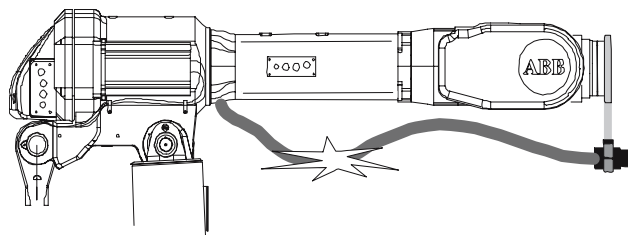

xx0300000168

Step	Action	Note/Illustration
1.	Adjust the retracting unit to reduce the slack in the hose package.	
2.	If this does not solve the problem, the manipulator movements must be limited. If this is not done, there is a substantial risk of damaging the hose/cable package.	
3.	After changing the DressPack upper arm installation, it needs to be inspected to ensure the function.	Detailed in section Installation of DressPack upper arm on page 38.

Hoses and cables too long

The hoses and cables at the end of the hose package are too long. The length should allow any required manipulator movement without stretching and also allow rotation inside the Proc cable support, axis 6.

The illustration below shows a DressPack upper arm fitted to an IRB 6400R, but the problem is identical to all manipulator types.

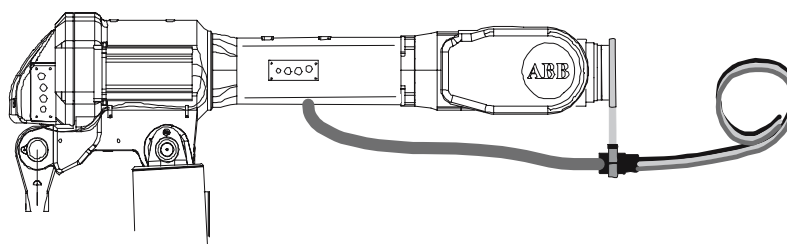

xx0300000169

Step	Action	Info/Illustration
1.	Cut the weldcable and hoses to a length that will suit the application before making any connections to the tool.	
2.	Loop the excess hoses and cables in a way that enables securing them with <i>cable clamps</i> or similar allowing quick replacement of the package.	When securing cables and hoses with cable ties: <i>never</i> overtighten the ties! This may damage the equipment.
3.	After changing the DressPack upper arm installation, it needs to be inspected to ensure the function.	Detailed in section Installation of DressPack upper arm on page 38.

2 Installation

2.5.3.1. Adjustment of DressPack upper arm

Process cable package too short

If the DressPack upper arm is too short, unacceptable strain may be put on the cables, hoses and connectors.

Step	Action	Note/Illustration
1.	Make sure the correct cable package is used. Remember that different upper arm lengths require different cable packages.	Check the DressPack, upper arm, std on page 162 section for article numbers!
2.	Make sure all attachments and supports are <i>fitted correctly</i> .	Detailed in section Installation of DressPack upper arm on page 38. If required adjust their fitting positions! When securing cables and hoses with cable ties: <i>never</i> overtighten the ties! This may damage the equipment.
3.	After changing the DressPack upper arm installation, it needs to be inspected to ensure the function.	Detailed in section Installation of DressPack upper arm on page 38.

2.6 DressPack floor

2.6.1. Installation of DressPack floor

Location of DressPack floor

The DressPack floor is made up of several components as shown in the figure below. Some of these components are specific to this application while others are used in other applications.

The configuration differs between different DressPack types: H, S, HS, Se, and HSe. The differences are specified below:

Type H

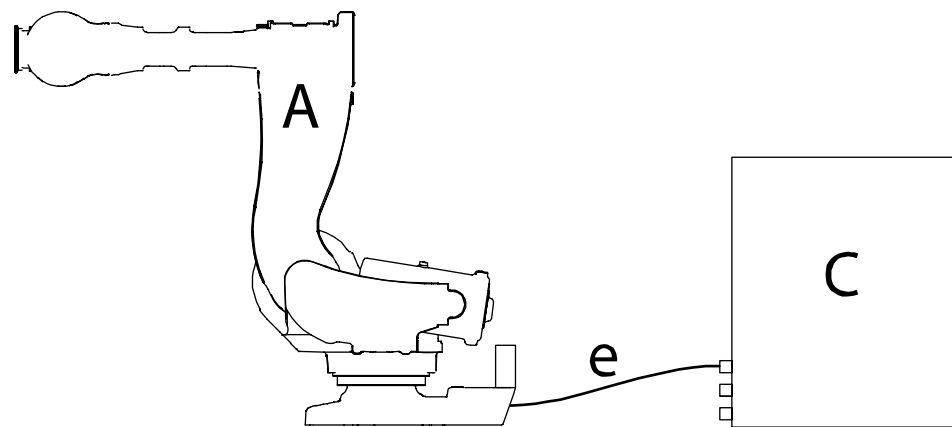

xx0300000213

A	Manipulator
C	S4Cplus Controller cabinet
e	Harness CP/CS (specified in the <i>DressPack, floor, std</i> on page 171 section)

2 Installation

2.6.1. Installation of DressPack floor

Type S

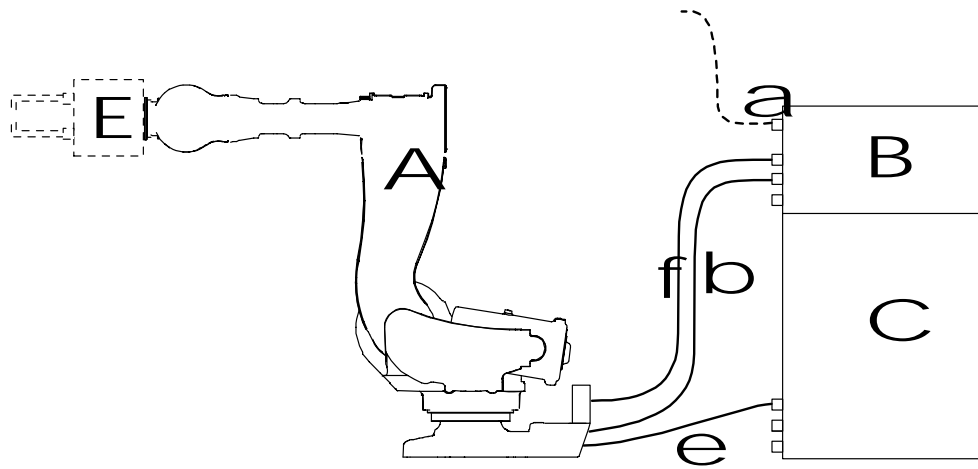

xx0300000214

A	Manipulator
B	SpotPack Power unit
C	S4Cplus Controller cabinet
E	Welding gun (supplied by user)
a	Shop weld power supply (supplied by user)
b	Floor weld cable
e	Harness CP/CS (specified in the <i>DressPack, floor, std</i> on page 171 section)
f	Split box cable (for water and air unit)

Type HS

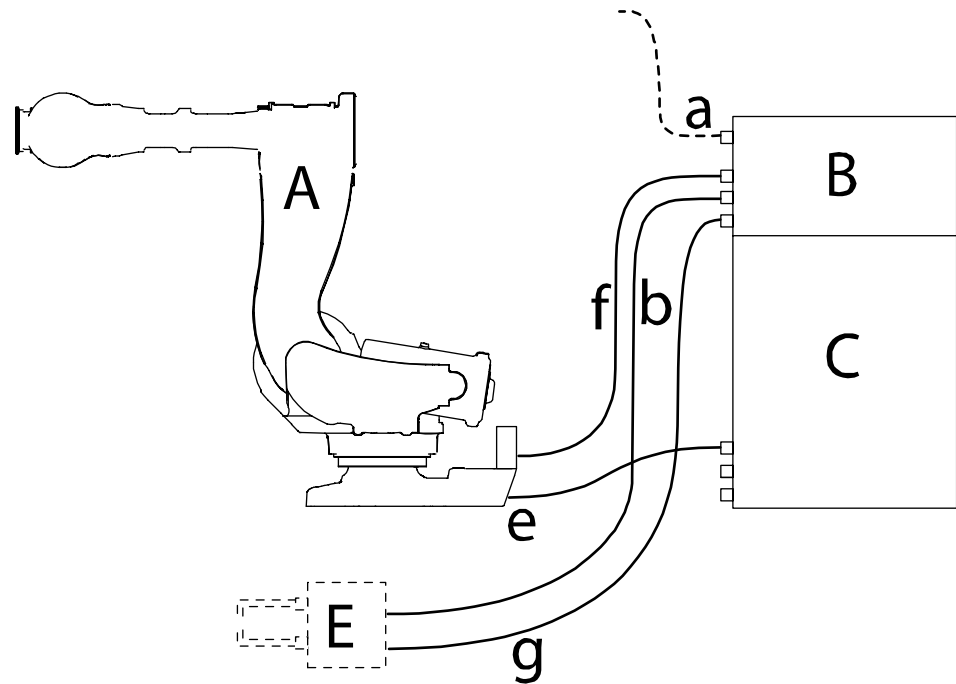

xx0300000215

A	Manipulator
B	SpotPack Power unit
C	S4Cplus Controller cabinet
E	Stationary/pedestal welding gun (supplied by user)
a	Shop weld power supply (supplied by user)
b	Floor weld cable
e	Harness CP/CS (specified in the <i>DressPack, floor, std</i> on page 171 section)
f	Split box cable (for water and air unit)
g	Process cable to stationary/pedestal gun

2 Installation

2.6.1. Installation of DressPack floor

Type Se

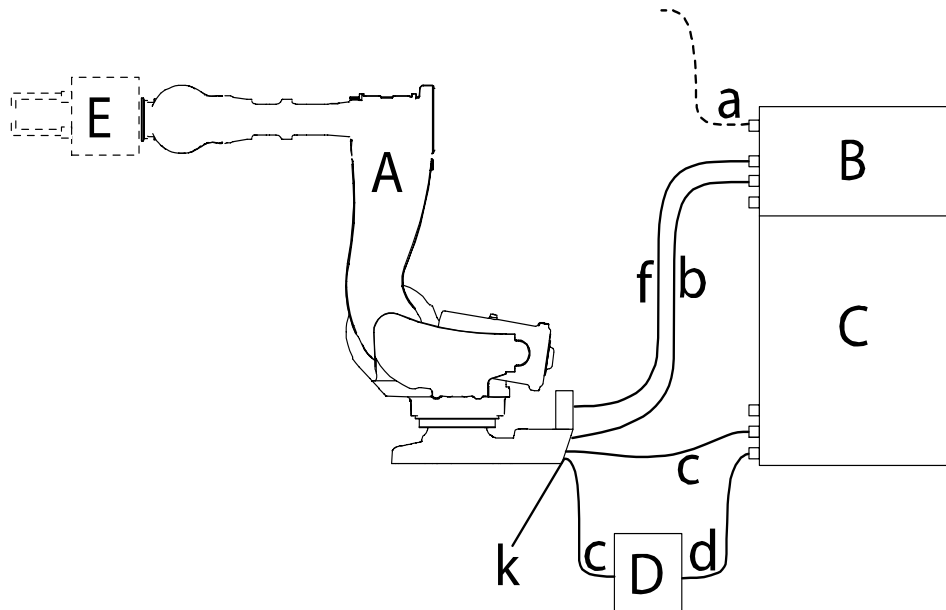

xx0300000216

A	Manipulator
B	SpotPack Power unit
C	S4Cplus Controller cabinet
D	Distributed Drive Unit (DDU, optional)
E	Welding gun (supplied by user)
a	Shop weld power supply (supplied by user)
b	Floor weld cable
c	Harness CP/CS, axis 7
d	Cable harness DDU
f	Split box cable (for water and air unit)
k	Jumper connector (for axis 7)

Type HSe

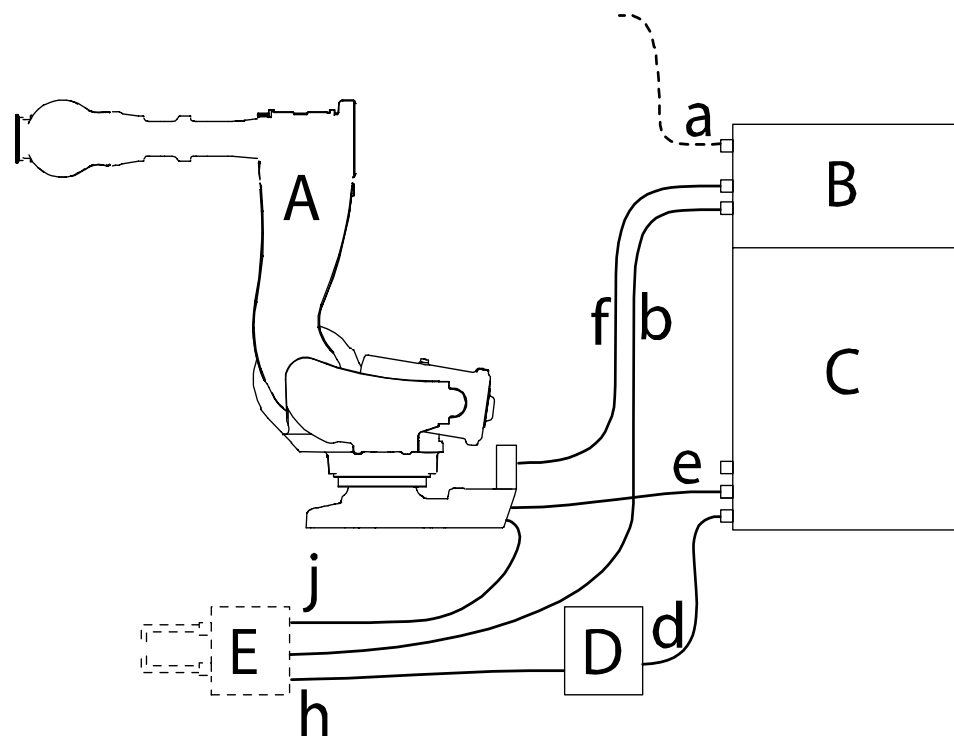

xx0300000217

A	Manipulator
B	SpotPack Power unit
C	S4Cplus Controller cabinet
D	Distributed Drive Unit (DDU, optional)
E	Stationary/pedestal welding gun (supplied by user)
a	Shop weld power supply (supplied by user)
b	Floor weld cable
c	Harness CP/CS
d	Cable harness DDU
e	Split box cable (for water and air unit)
f	Cable: DDU to stationary/pedestal gun
g	SMB signal cable, 7 m
h	Cable: DDU to stationary/pedestal gun

Required equipment

Equipment, etc.	Spare part no.	Art. no.	Note
DressPack floor		See the Spare parts section!	A number of versions are available.
Standard Toolkit, DressPack/SpotPack		3HAC 17290-7	The contents are defined in section Standard toolkit!

2 Installation

2.6.1. Installation of DressPack floor

Equipment, etc.	Spare part no.	Art. no.	Note
Circuit Diagram		3HAC 17669-2	DressPack for IRB 6600, 6650 and 7600 using <i>pneumatic</i> welding gun
Circuit Diagram		3HAC 17669-1	DressPack for IRB 6600, 6650 and 7600 using <i>servo</i> welding gun



CAUTION!

The cable packs are sensitive to mechanical damage! They must be handled with care, especially the connectors, in order to avoid damaging them!

Installation

The procedure below details how to install the DressPack floor. It does not deal with details specific to each version, such as article numbers, connector types, etc. Such details are specified in the Spare Parts section.

Step	Action	Note/Illustration
1.	Determine which type of installation is to be done. Study the illustration to decide which cables to connect.	The different types are shown in section Location of DressPack floor on page 53.
2.	Whenever possible, run all cables/hoses in cable ducts or trenches. Make sure these meet the required standards.	Make sure: <ul style="list-style-type: none">• no floor weld cable is routed along signal cabling to minimize the risk of interference!• the duct/trench floor is free from sand and other contamination. This is to reduce the risk of damaging the cable insulation.• no cables or hoses rub against any sharp corners which might damage them.
3.	<i>Do not bend or twist</i> any cable or hose excessively!	Minimum bending radius is approximately 10 x the cable or hose diameter.
4.	Make sure all cables straps are tight enough to prevent the cable package from moving in any undesired way.	
5.	Remember that switching the weld power as well as the water ON and OFF may cause the cables/hoses to move slightly! They may require additional clamping to avoid damage caused by these movements.	

Step	Action	Note/Illustration
6.	Connect the shop power supply to the power unit.	The supply needs to be configured in such a way that the requirements of the Power Unit are met: <ul style="list-style-type: none"> • Voltage: 400-480 VAC, 50/60 Hz • Fuse: 110 A • Earth fault protection: specified in section <i>Installation of power unit, std</i> on page 76. • Contactor: specified in section <i>Installation of power unit, std</i> on page 76.
7.	Connect the floor weld cable to the <i>manipulator and power unit connectors</i> .	Specified in section <i>Connections</i> on page 59 and the <i>Spare Parts</i> chapter.
8.	Select which <i>CP/CS cabling</i> (customer power/customer signals) to be used.	Some versions include industrial buses, others include axis 7 cabling, others do not! Specified in section <i>Connections</i> on page 59 and the <i>Spare Parts</i> chapter.
9.	Connect the CP/CS cable to the <i>manipulator and controller cabinet connectors</i> .	Specified in section <i>Connections</i> on page 59 and the <i>Spare Parts</i> chapter.
10.	If used, connect the split box cable to the water and air unit on the manipulator and to the power unit <i>connectors</i> .	Specified in section <i>Connections</i> on page 59 and the <i>Spare Parts</i> chapter.
11.	If used, connect the Process cable to stationary/pedestal gun to the <i>power unit and stationary/pedestal gun connectors</i> .	A stationary/pedestal gun is optional. Specified in section <i>Connections</i> on page 59 and the <i>Spare Parts</i> chapter.
12.	If used, connect the Cable harness DDU to the <i>controller cabinet and DDU connectors</i> .	A DDU (Distributed Drive Unit) is optional. Specified in section <i>Connections</i> on page 59 and the <i>Spare Parts</i> chapter.
13.	If used, connect the Cable: DDU to stationary/pedestal gun to the <i>stationary/pedestal gun and DDU connectors</i> .	DDU (Distributed Drive Unit) and stationary/pedestal gun are optional. Specified in section <i>Connections</i> on page 59 and the <i>Spare Parts</i> chapter.
14.	If used, connect the jumper connector to the base of the manipulator.	Jumper connector is optional, and only used when Type Se is chosen. Specified in section <i>Connections</i> on page 59 and the <i>Spare Parts</i> .

Connections

The table specifies the connection points of all cables. It does not deal with details specific to each version, such as article numbers, cable lengths, connector types, etc. Such details are specified in the *DressPack, floor, std* on page 171 section.

2 Installation

2.6.1. Installation of DressPack floor

Some of the cables occupy the same connectors, so they may not be used simultaneously.

Item in illustration	Connection point A	Cable	Connection point B
a	Shop power outlet	Shop weld power supply	Power unit; protective earth (PE), U, V and W according to circuit diagram.
b	Manipulator; R1.WELD	Floor weld cable	Power unit; as specified in the Circuit Diagram
c	Manipulator; R1.CP/CS	Harness CP/CS, axis 7	Controller cabinet; XS13 DDU; XS77
d	DDU; XP49	Cable harness DDU	Controller cabinet; XS44
e	Manipulator; R1.CP/CS Manipulator; R1.CP/CS Manipulator; R1.CP/CS Manipulator; R1.CP/CS	Harness CP/CS PROFIB Harness CP/CS CAN Harness CP/CS IBS Harness CP/CS	Controller cabinet; XS13 Controller cabinet; XS13 Controller cabinet; XS13 Controller cabinet; XS13
f	Manipulator; Water and Air unit; XP101	Power unit to split box cable	Power unit; XS103
g	Stationary/pedestal gun; SG.CP/CS (optional)	Process cable to stationary/pedestal gun	Power unit; XS104
h	Stationary/pedestal gun; SG.CP/CS	Harness servo gun	DDU; XS77/78
j	Manipulator; R3.FB7	SMB signal cable, 7 m	Stationary/pedestal gun; FB.M7
k	Manipulator; R3, FB7	Jumper connector	

2.6.2. Inspection, DressPack floor

General

In order to ensure adequate life of the equipment, it is vital that the cables and hoses are properly installed and operated correctly, with their movement patterns well within the acceptable limits.

This instruction details how to inspect the DressPack floor installation in this regard.

Procedure, Process cable package

This section details each inspection to be carried out, not necessarily in any particular order unless stated.

Step	Action	Info/Illustration
1.	Make sure that the cable package is properly connected at the manipulator base as well as at the other end.	
2.	Make sure that no hoses or cables, or parts thereof, are routed in such a way that they are subjected to wear, for example hoses being run over by fork lifts etc.	
3.	Make sure that no cables or hoses rub against any sharp corners which might damage them.	
4.	Make sure all connection points are well tightened and sealed in order to avoid leaks.	

2 Installation

2.7.1. Installation of Water and Air unit, SpotPack

2.7 Water & air unit

2.7.1. Installation of Water and Air unit, SpotPack

Location of Water and Air unit

The Water and Air unit is located as shown in the figure below.

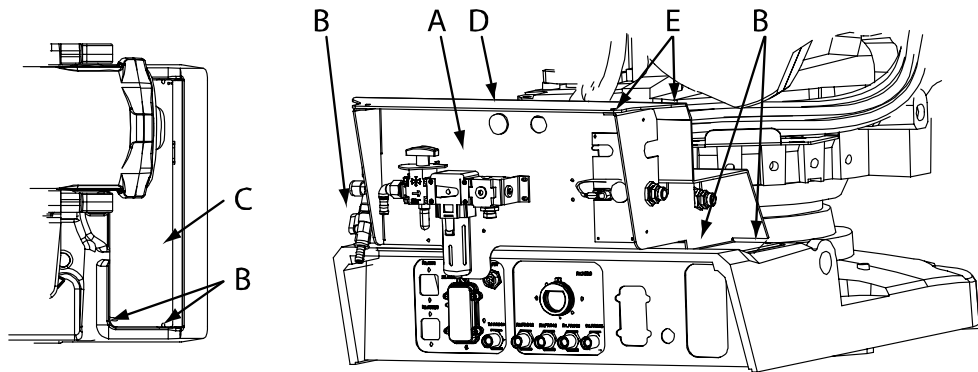

xx0300000144

A	Water and Air unit
B	Unit attachment screws (4 pcs)
C	Top rear cover
D	Water & air unit top cover
E	Attachment screws, water & air unit top cover, (4 pcs)

General technical data

The table below shows technical data of water and air pressure

Parameter	Value
Maximum water pressure	10 bar / 145 PSI
Maximum air pressure	16 bar / 230 PSI

The table below shows technical data of water and air quality

Parameter	Value
Water quality	Normal filtered industrial water quality
Air quality	Normal filtered industrial air quality

Required equipment

Equipment, etc.	Spare part no.	Art. no.	Note
Water and Air unit		See the Spare parts section!	A number of versions are available. The Water and Air unit assembly contains all required hardware for fitting and connecting
Standard Toolkit, DressPack/SpotPack		3HAC 17290-7	The contents are defined in section Standard toolkit!
Circuit Diagram		3HAC 17669-2	DressPack for IRB 6600, 6650 and 7600 using <i>pneumatic</i> welding gun
Circuit Diagram		3HAC 17669-1	DressPack for IRB 6600, 6650 and 7600 using <i>servo</i> welding gun

Installation

The procedure below details how to install the Water and Air unit.

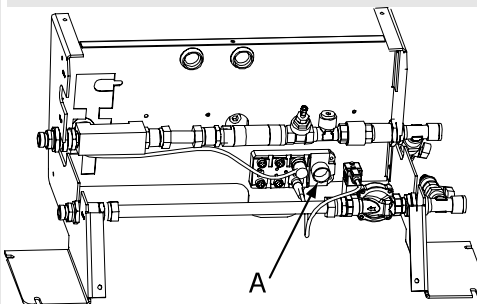
Step	Action	Note/Illustration
1.	Make sure the power to the manipulator has been switched off.	
2.	Remove the <i>top rear cover</i> by unscrewing its four <i>attachment screws</i> .	Shown in the figure in section Location of Water and Air unit on page 62.
3.	Fit the water and air unit and secure it with the four attachment screws.	Reuse the screws for top rear cover.
4.	Connect the water and air supplies.	Specified in section Connections to Water and Air unit on page 64.
5.	Open the water and air unit top cover by removing its attachment screws.	Shown in the figure in section Location of Water and Air unit on page 62.
6.	Connect the split box cable for water and air unit with the split box at the water and air unit.	 <p>xx0300000146</p> <p>The illustration shows the water and air unit with its cover removed.</p> <p>Parts:</p> <ul style="list-style-type: none"> A: Split box connection at the water and air unit, XS101.
7.	Refit the water and air unit top cover and secure it with its attachment screws.	Shown in the figure in section Location of Water and Air unit on page 62.

2 Installation

2.7.1. Installation of Water and Air unit, SpotPack

Connections to Water and Air unit

The figure below shows the connections to the manipulator base.

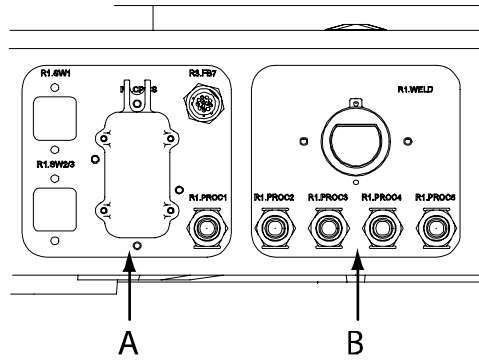

xx030000058

A	Plate customer
B	Plate PROC

The figure below shows the connections on the water and air unit.

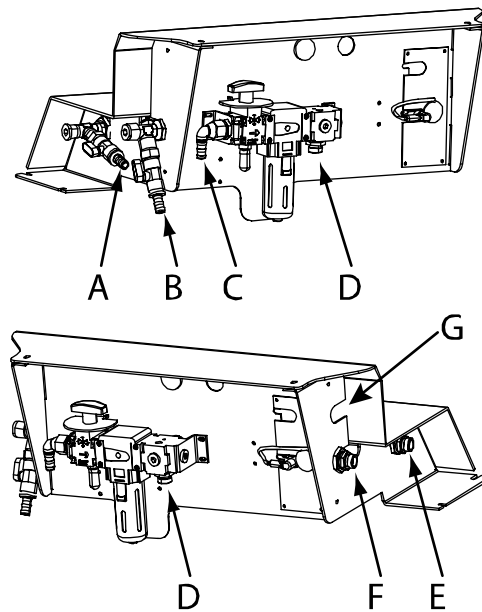

xx0300000145

Item in figure	Connect to:	Function:
A	Shop water supply	
B	Shop water drain	
C	Shop compressed air supply	
D	PROC1 on manipulator base	Compressed air supply to manipulator
E	PROC2 on manipulator base	Water in circuit

Item in figure	Connect to:	Function:
F	PROC3 on manipulator base	Water return circuit
G	PROC4 on manipulator base Note! Only the position of this connection is shown in the illustration above!	Depending on option selected: <ul style="list-style-type: none"> • 2nd water return circuit • Regulated air

Shop water supply

The procedure below details how to connect the water and air unit to the shop water supply.

Step	Action	Info/Illustration
1.	Unfasten the hand operated water valves for inlet and outlet of water.	
2.	Connect the Parker pushlok adapters on the hoses marked "Shop water supply" and "Shop water drain".	½" Parker pushlok no. 3D982-8-8BK
3.	If Parker pushlok hoses not are used, use hose clamps!	
4.	Remount the hand operated water valves (with hoses mounted), on their respective places: "Water inlet" and "Water outlet".	
5.	Secure the connectors of the water valves.	See Tightening torque on page 13 in section Screw joints .
6.	Close the hand operated water valves.	

Shop compressed air supply

The procedure below details how to connect the water and air unit to the shop compressed air supply.

Step	Action	Info/Illustration
1.	Unfasten the 90° Parker pushlok elbow adapter for compressed air, on the air unit.	½" Parker pushlok no. 39C82-15-8BK
2.	Push the 90° Parker pushlok elbow adapter on to the hose for the shop compressed air supply.	
3.	If Parker pushlok hoses not are used, use hose clamps.	
4.	Remount the 90° elbow valve (with the hose mounted) on the air unit at <i>Air in</i> .	
5.	Secure the connector of the air valve.	See Tightening torque on page 13 in section Screw joints .
6.	Close the hand operated compressed air valves.	

Hoses connecting manipulator and water and air unit

The procedure below details how to connect hoses between manipulator and water and air unit.

2 Installation

2.7.1. Installation of Water and Air unit, SpotPack

There are two versions of the hose water and air unit used:

- **Proc 1** version is the one with two straight Parker pushlok nipples.
- **Proc 2, 3 and 4** are the ones with one straight and one 90° elbow Parker pushlok nipples.

Step	Action	Info/Illustration
1.	Connect Proc 1 on the water and air unit with Proc 1 on the manipulator.	
2.	Connect Proc 2 on the water and air unit with Proc 2 on the manipulator.	
3.	Connect Proc 3 on the water and air unit with Proc 3 on the manipulator.	
4.	Connect Proc 4 on the water and air unit with Proc 4 on the manipulator.	
5.	Secure all connectors.	See <i>Tightening torque</i> on page 13 in section <i>Screw joints</i> .

2.7.2. Mechanical flow switch

Introduction

The mechanical flow switch is pre-set at delivery at 3.5 liters/min $\pm 15\%$.

Settings

The procedure below details how to set the mechanical flow switch.

Step	Action	Info/Illustration
1.	Dismantle the cover of water and air unit.	
2.	Open the hand-operated water valve for inlet and outlet.	
3.	Open the solenoid valve on the water inlet.	
4.	Water flow is indicated on the flow indicator located under the top cover of the water and air unit.	
5.	Adjust water flow with the gate valve, to required alarmflow.	
6.	Loosen the indicator on the flow indicator and move the indicator to the required position.	One Philips screw.
7.	The flow indicator shall signal when the water flow decreases to alarmflow set. An orange diode shall also be lit on the indicator.	
8.	Set the position of the indicator.	Philips screw.
9.	Increase water flow by opening the gate valve until the diode is no longer lit.	
10.	Reduce water flow with the gate valve until the diode is lit.	
11.	Check if water flow is the same as required alarm flow. If not, adjust the setting.	
12.	Increase water flow to normal by adjusting the gate valve.	
13.	Remount the cover of water and air unit.	

2 Installation

2.7.3. Digital flow switch - Introduction

2.7.3. Digital flow switch - Introduction

Introduction

The digital flow switch is available as an option.

The procedures below details necessary knowledge about the principle function of the digital flow switch. It also describes necessary preparations before settings.

General operating instructions

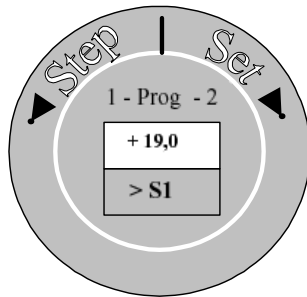

xx0400001003

A Principle drawing of the Program ring

The following list is describing in general how to operate the digital flow switch.

- The digital flow switch has a program ring. If the white text "Step Set" (as in figure above) is shown, programming is possible. If the red text "Prog Stop" is shown, the program ring must be turned around, in order to enable programming.
- The program ring can be swivelled to Pos. 1 and Pos. 2 depending on what action is to be taken.
- The program ring allows to **display parameters** (Pos. 1), as well as to **modify parameters** (Pos. 2).
- The neutral position of the program ring is achieved by central location of the ring partition between Pos. 1 and 2.
- The various functions are triggered by turning the partition versus Pos. 1 (= STEP) or Pos. 2 (= EDIT).

Position	Action
Pos. 1	Displays parameters or next position (STEP)
Pos. 2	Modification of parameters (EDIT)

Preparations

The procedure below details how to make necessary preparations before setting the digital flow switch.

Step	Action	Info/Illustration
1.	Dismantle cover of water and air unit.	
2.	Open hand operated water flow valve for inlet and outlet.	
3.	Open solenoid valve on water and air unit	
4.	Adjust water flow to normal alarmflow by adjusting gate valve. The water flow can be seen on the digital flow switch.	How to set the alarmflow, see Digital flow switch - Settings on page 70 .
5.	Remount cover of water and air unit.	

Pre-set values

The table below shows pre-set parameters, set at delivery.

Parameter	Pre-set value
Nominal value of SET S1.	3.5 liters/min
The function of SET S1 (min. or max.)	Min.
SET Hyst 1	0
Nominal value of SET S2	20
The function of SET S2 (min. or max.)	Max.
SET Hyst 2	0
SET CODE	0000

2 Installation

2.7.4. Digital flow switch - Settings

2.7.4. Digital flow switch - Settings

Principles of programming settings

The procedure below details the principles how to program the digital flow switch.

Step	Action	Info/Illustration
1.	Choice of menus is performed by turning the black program ring on the flow indicator repeatedly counterclockwise approximately $\frac{1}{4}$ rev.	Turn the ring towards Pos. 1 (STEP).
2.	To reset a programmed value, turn the black program ring repeatedly clockwise approximately $\frac{1}{4}$ rev. NOTE! It is not possible to decrease a value! If a value is set too high, the black program ring has to be turned repeatedly clockwise until required value appears.	Turn the ring towards Pos. 2 (EDIT)
3.	In case of no further action, the switch indicator returns to <i>regular measurements display</i> after about 10 sec.	

Setting of decimal numbers

When performing the following procedures it is assumed that the different procedure steps described below are performed in the same order as described here. It is also possible to set values separately by stepping Pos. 1 to wanted position.

The following procedure details how to program decimal numbers on the digital flow switch.

Step	Action	Info/Illustration
1.	Turn the black program ring counterclockwise $\frac{1}{4}$ rev. and then back $\frac{1}{4}$ rev. to neutral position.	
2.	A cursor appears at chosen parameter (in this example: <i>decimal number</i>) on the display.	
3.	The flow indicator is now showing S1 (= alarm value S1). The value shown is the preset value 3.5 liters/min, when setting is done for the first time after delivery.	
4.	Turn the black program ring clockwise $\frac{1}{4}$ rev. and then back $\frac{1}{4}$ rev. to neutral position.	
5.	The flow indicator is now showing S1 3.6 liters/min.	
6.	Repeat steps 4 and 5 until required decimal number value is reached.	

Setting of unit digits

The procedure below details how to program unit digits on the digital flow switch.

Step	Action	Info/Illustration
1.	Turn the black program ring counterclockwise $\frac{1}{4}$ rev. and then back $\frac{1}{4}$ rev. to neutral position.	
2.	A cursor appears at chosen parameter (<i>unit</i> digit) on the display.	
3.	The flow indicator is now showing S1 (=alarm value S1) and the value shown is 3.6 liters/min.	
4.	Turn the black program ring clockwise $\frac{1}{4}$ rev. and then $\frac{1}{4}$ rev. back to neutral position.	
5.	The flow indicator is now showing S1 4.6 liters/min.	
6.	Repeat steps 4 and 5 until required unit digit value is reached.	

Setting of tens digits

The procedure below details how to program tens digits on the digital flow switch.

Step	Action	Info/Illustration
1.	Turn the black program ring counterclockwise $\frac{1}{4}$ rev. and then back $\frac{1}{4}$ rev. to neutral position.	
2.	A cursor appears at chosen parameter (<i>tens</i> digit) on the display.	
3.	The flow indicator is now showing S1 (= alarm value S1) and the value shown is 4.6 liters/min.	
4.	Turn the black program ring clockwise $\frac{1}{4}$ rev. and then back $\frac{1}{4}$ rev. to neutral position.	
5.	The flow indicator is now showing S1 14.6 liters/min.	
6.	Repeat steps 4 and 5 until required tens digit value is reached.	
7.	Programmable area is 2 - 15 liters/min.	

2 Installation

2.7.5. Pressure switch

2.7.5. Pressure switch

Setting

The pressure switch is available as an option.

The pressure switch is pre-set on delivery at 5 bar.

The procedure below details how to set the pressure switch, if pressure must be adjusted.

Step	Action	Info/Illustration
1.	Open the hand operated air valve.	
2.	Set required air pressure with the pressure regulator.	
3.	Adjust pressure with the adjusting screw S1 on the pressure switch, until the diod is lit.	
4.	Adjust pressure with the adjusting screw S1 on the pressure switch, just enough until the diod is put out.	
5.	Check level of alarm pressure set, by increasing air pressure until the diod is lit. Then carefully decrease air pressure.	
6.	When level of alarm pressure is reached, the diod is put out.	
7.	Set S2 to maximum counterclockwise.	Alarm pressure level S2 is not used!

2.7.6. Proportional valve

Setting

The proportional valve is available as an option.

The procedure below details how to set the proportional valve, if pressure must be adjusted.

Step	Action	Info/Illustration
1.	The output pressure from the proportional valve is set by voltage control.	See circuit diagram!
2.	0 - 1 volt gives an output pressure of 1.2 Bar.	
3.	10 volts gives an output of 12 Bar.	An output pressure of 12 Bar requires that shop air pressure is at least 12 Bar.

2 Installation

2.7.7. Split box

2.7.7. Split box

Connections

The table below details the connections on the split-box.

Unit	Connection	Remark
Water valve	XS101.1	See circuit diagram!
Flow switch 1	XS101.2	See circuit diagram!
Flow switch 2 (option)	XS101.3	See circuit diagram!
Pressure switch (option)	XS101.4	See circuit diagram!
Proportional valve (option)	XS101.5	See circuit diagram!
-	XS101.6	Not used!

Jumpers

If none of the options in the table above has been chosen, the contacts has jumpers installed in the split-box at delivery.

The jumpers are needed in order to get the SpotPack software working properly.

Jumpers: a 20 mm long wire (EK 0.75) is connected between socket 1 and 4 in respective contact.

2.8 Power unit

2.8.1. Lifting the power unit

General

The power unit is usually fitted on top of a S4Cplus controller cabinet on delivery, but it is also possible to refit it to an existing controller cabinet. This procedure details how to lift a separate power unit as well as a complete controller cabinet.

Due to the heavy weight of the power unit, special considerations must be taken when lifting the unit.

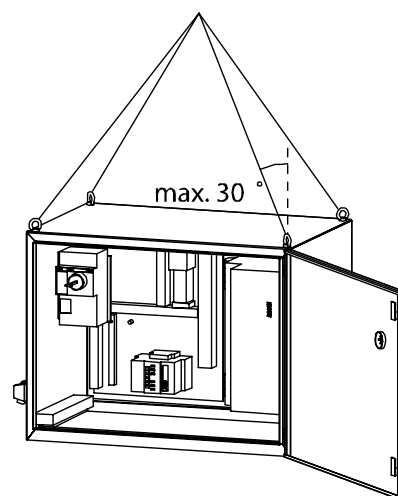

xx030000082

Procedure



WARNING!

The power unit may be lifted separately or fitted to the top of the S4Cplus controller cabinet! Use a suitable lifting device to avoid injury to personnel!

- Separate Power unit: up to 150 kg
- Complete S4Cplus controller cabinet fitted with Power Unit: up to 400 kg

Step	Action	Info/Illustration
1.	Fit lifting slings to the power unit top.	Make sure the slings' capacity matches the weight of the power unit! Shown in the figure in section General on page 75.
2.	Gently stretch the slings to take up the slack before lifting.	
3.	Lift and run the power unit to its intended position.	

2 Installation

2.8.2. Installation of power unit, std

2.8.2. Installation of power unit, std

Location of power unit

The power unit is located as shown in the figure below.

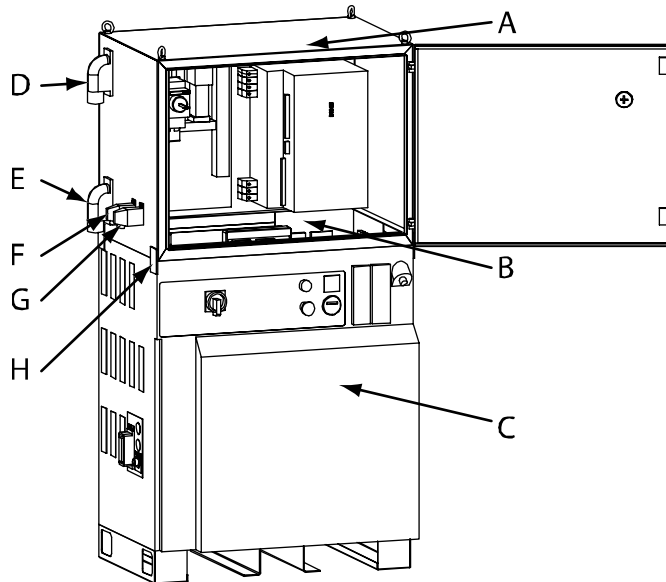

xx0300000147

A	Power unit
B	Area for accessing signal connections between power unit and controller
C	S4Cplus controller cabinet
D	Cable gland, shop power supply
E	Cable gland, power supply to manipulator
F	Connection, split box cable, XS103
G	Connection, stationary/pedestal gun, XS104
H	Enclosure bracket (4 pcs) with attachment screws (16 pcs in total)

Required equipment

Equipment, etc.	Spare part no.	Art. no.	Note
Power unit		See the Spare parts section!	A number of versions are available. The Power unit contains all required hardware for fitting and connecting.
Standard Toolkit, DressPack/SpotPack		3HAC 17290-7	The contents are defined in section Standard toolkit!
Circuit Diagram		3HAC 17669-2	DressPack for IRB 6600, 6650 and 7600 using <i>pneumatic</i> welding gun
Circuit Diagram		3HAC 17669-1	DressPack for IRB 6600, 6650 and 7600 using <i>servo</i> welding gun

Installation

The procedure below details how to fit the power unit to a standard S4Cplus controller cabinet.



WARNING!

Please observe the following before commencing any work on the controller or units connected to the controller:

- - Turn off all electric power supplies to the cabinet!
- - Many components inside the cabinet or inside any external units are sensitive to ESD (ElectroStatic Discharge) and will be destroyed if subjected to it!
- - Before handling, make sure you are grounded through a special ESD wrist bracelet or similar. Many module and unit fronts are fitted with a special ESD protection button for connection of the bracelet. Use it!

Step	Action	Note/Illustration
1.	Make sure the power to the controller has been switched off.	
2.	Unlock the controller top and remove the hinge screws on the rear of the cabinet.	
3.	Remove the controller top.	
4.	Lift the power unit on top of the S4Cplus controller.	Detailed in section Lifting the power unit on page 75.
5.	Secure the power unit on top of the controller with the four <i>enclosure brackets</i> with four <i>screws</i> each.	Included in the kit. Make sure the fibre ESD strip is not displaced on the circumference of the cabinet top.
6.	Is the power unit to be installed equipped with <i>earth fault protection</i> ? If YES: connect the power unit as specified in the Circuit Diagram! If NO: make sure the installation can be earth fault protected as required.	Note that local laws and regulations may require the installation to be fitted with earth fault protection. The demands are specified in section Earth fault protection on page 77.
7.	Is the power unit to be installed equipped with <i>contactor</i> ? If YES: connect the power unit as specified in the Circuit Diagram! If NO: make sure the installation can be isolated as required.	Note that local laws and regulations may require the installation to be fitted with a disconnector. Other reasons are The demands are specified in section Contactor on page 78.
8.	Make all power and signal connections as specified in the <i>Circuit Diagram</i> .	Specified in section Required equipment on page 76. All connection points, referred to in the Circuit Diagram, are labeled in the controller cabinet.

Earth fault protection

The installation must be fitted with some sort of earth fault protection **if any local regulations require this**.

2 Installation

2.8.2. Installation of power unit, std

This may be integrated with the power unit itself (option available from ABB), or be installed on the external shop power supply. If an alternative other than the one available from ABB is chosen, the **local installer is responsible** for the compliance to any national or international standards and regulations.

Three different installation alternatives a), b) and c) are specified in the illustration below:

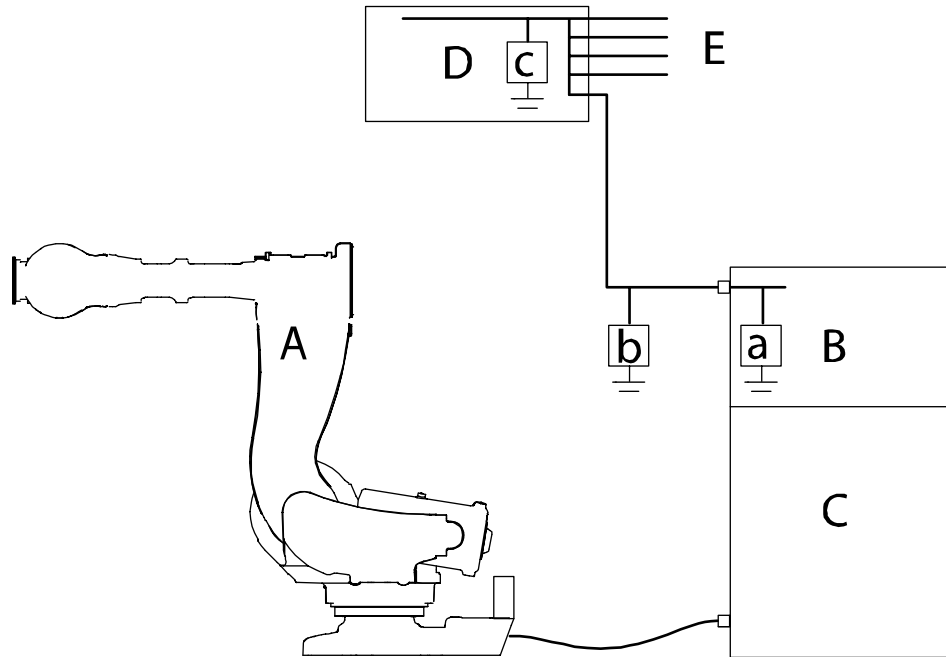

xx0300000175

A	Manipulator
B	Power unit
C	S4Cplus controller cabinet
D	External shop power supply (by customer/user)
E	Equipment group, supplied by external shop power supply
a	Integrated earth fault protection
b	External earth fault protection for the power unit <i>only</i>
c	External earth fault protection for equipment group including the power unit

The table below shows the requirement specification regarding the earth fault protection:

Voltage, AC welder	400 - 600 VAC, 50/60 Hz
Voltage, MFDC welder	400 - 480 VAC, 50/60 Hz
Current	110 A, RMS

Contactor

The installation **may** be fitted with some sort of contactor (electro-mechanical disconnecter):

- **if any local regulations require this**
- to protect any personnel working with the equipment

- to protect any pieces of equipment
- to enable monitoring of system status POWER ON

This may be integrated with the power unit itself (option available from ABB), or be installed on the external shop power supply. If an alternative other than the one available from ABB is chosen, the **local installer is responsible** for the compliance to any national or international standards and regulations.

Three different installation alternatives a), b) and c) are specified in the illustration below:

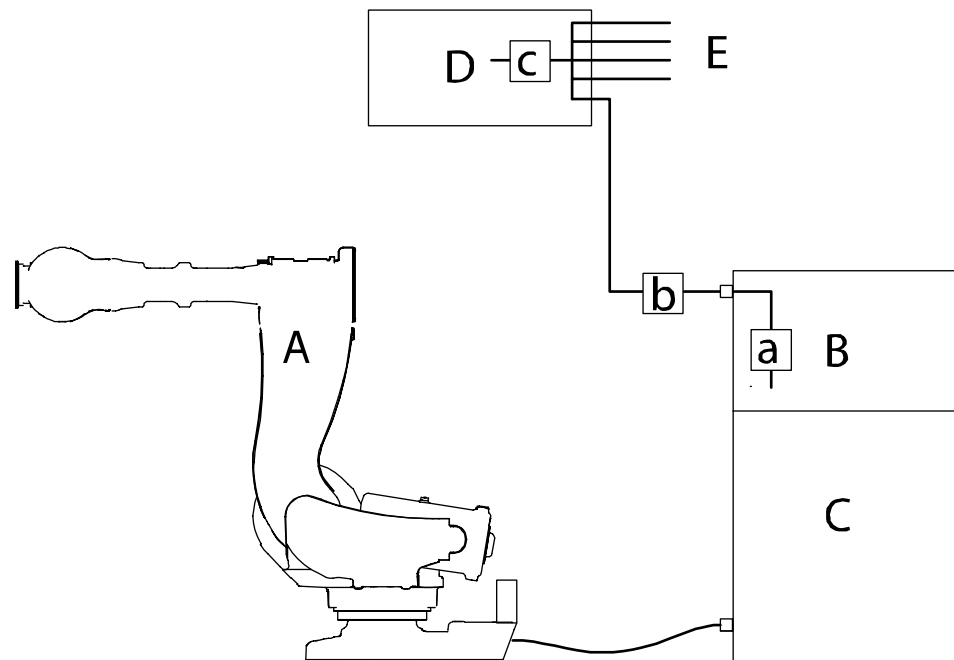

xx0300000177

A	Manipulator
B	Power unit
C	S4Cplus controller cabinet
D	External shop power supply (by customer/user)
E	Equipment group, supplied by external shop power supply
a	Integrated contactor
b	External contactor for the power unit <i>only</i>
c	External contactor for equipment group including the power unit

The table below shows the requirement specification regarding the contactor:

Voltage, AC welder	400 - 600 VAC, 50/60 Hz
Voltage, MFDC welder	400 - 480 VAC, 50/60 Hz
Current	110 A, RMS

2 Installation

2.8.2. Installation of power unit, std

3 Maintenance

3.1. Introduction

Structure of this chapter

This chapter details all maintenance activities recommended for the robot and any external units of the robot.

It is based on the maintenance schedule, located in the beginning of the chapter. The schedule contains information about required maintenance activities including periodicity and refers to procedures for the activities.

Each procedure contains all information required to perform the activity, e.g. required tools and materials.

The procedures are gathered in different sections, divided according to the maintenance activity.

Safety information

Before any service work is commenced, it is extremely important that all safety information is observed!

There are general safety aspects that must be read through, as well as more specific safety information that describe danger and safety risks when performing the procedures. Make sure to read through the chapter *Safety*.

3 Maintenance

3.2.1. Maintenance schedule, SpotPack

3.2 Maintenance schedules and component lives

3.2.1. Maintenance schedule, SpotPack

General

The SpotPack equipment must be maintained regularly to ensure its function. It is the responsibility of the operator to do so. The maintenance activities and their respective intervals are specified in the table below.

The inspection intervals *do not* specify the life of each component.

Activities and intervals, standard equipment

The sections referred to in the table can be found in the different chapters for each maintenance activity.

The table below specifies the required maintenance activities and intervals:

Maintenance activity	Equipment	Interval	Note	Detailed in section:
Inspection	Water & Air unit	1 month		" Preventive inspection of water and air unit on page 91"
Inspection	Power unit	Regularly *)		" Preventive inspection of power unit on page 94"
Inspection	All cables	Regularly *)		" Preventive inspection of all cables, SpotPack on page 83"
Inspection	DressPack upper arm	Regularly *) After changing the movement pattern of the manipulator		" Preventive inspection, DressPack upper arm on page 85"
Cleaning	DressPack upper arm	Regularly *)		" Cleaning, DressPack upper arm on page 96"
Cleaning	Water & Air unit	Regularly *)		" Cleaning, water and air unit on page 98"

*) "Regularly" implies that the activity is to be performed regularly, but the actual interval may not be specified by the robot manufacturer. The interval depends on the operation cycle of the robot, its working environment and movement pattern.

Generally, the more contaminated the environment, the closer the maintenance intervals. Also, the more demanding the movement pattern (sharper bending cable harness), the closer the intervals.

3.3 Inspection activities

3.3.1. Preventive inspection of all cables, SpotPack

Cables, in the SpotPack system

There are many different cables used in the SpotPack system. The different cables used, are listed in Spare Parts section.

The inspection activities described below are a general description, and does not refer to any specific cable.

Required equipment

Equipment	Spare part no.	Art. no.	Note
Standard Toolkit, DressPack/SpotPack		3HAC 17290-7	The contents are defined in section Standard toolkit!



WARNING!

Please observe the following before commencing any work on the controller or units connected to the controller:

- Turn off all electric power supplies to the cabinet!
- Many components inside the cabinet or inside any external units are sensitive to ESD (ElectroStatic Discharge) and will be destroyed if subjected to it!
- Before handling, make sure you are grounded through a special ESD wrist bracelet or similar. Many module and unit fronts are fitted with a special ESD protection button for connection of the bracelet. Use it!

Inspection

The procedure below details how to inspect all cables included in the SpotPack system.

This instruction applies to:

- DressPack upper arm and cables and hoses contained within
- DressPack lower arm and cables and hoses contained within
- DressPack floor and cables and hoses contained within

Step	Action	Note/Illustration
1.	Check that the unit is clean and not overly contaminated.	Clean if required as detailed in section Cleaning, DressPack upper arm on page 96.
2.	Check that all bolts are fastened.	Recommended tightening torques are specified in section Screw joints on page 13.
3.	Check that all connections are safely made and that there are no leaks.	Retighten if necessary.

3 Maintenance

3.3.1. Preventive inspection of all cables, SpotPack

Step	Action	Note/Illustration
4.	Check for mechanical wear, especially in areas where the cable/hose package rub against or move close to the manipulator or any other structure. Especially check any cable/hose package at the manipulator wrist and the junction point at the rear of the upper arm.	Replace any worn items as detailed in the Repair chapter. Readjust the assembly after installation.
5.	Check the attachment of any cable/hose package to make sure they are properly secured.	Secure any loose items as detailed in the Installation chapter.
6.	Check all cable retainers to make sure the cables/hoses are securely locked in the cable retainers.	Tighten any loose retainers as detailed in section Installation of DressPack upper arm on page 38.

3.3.2. Preventive inspection, DressPack upper arm

Location of DressPack upper arm

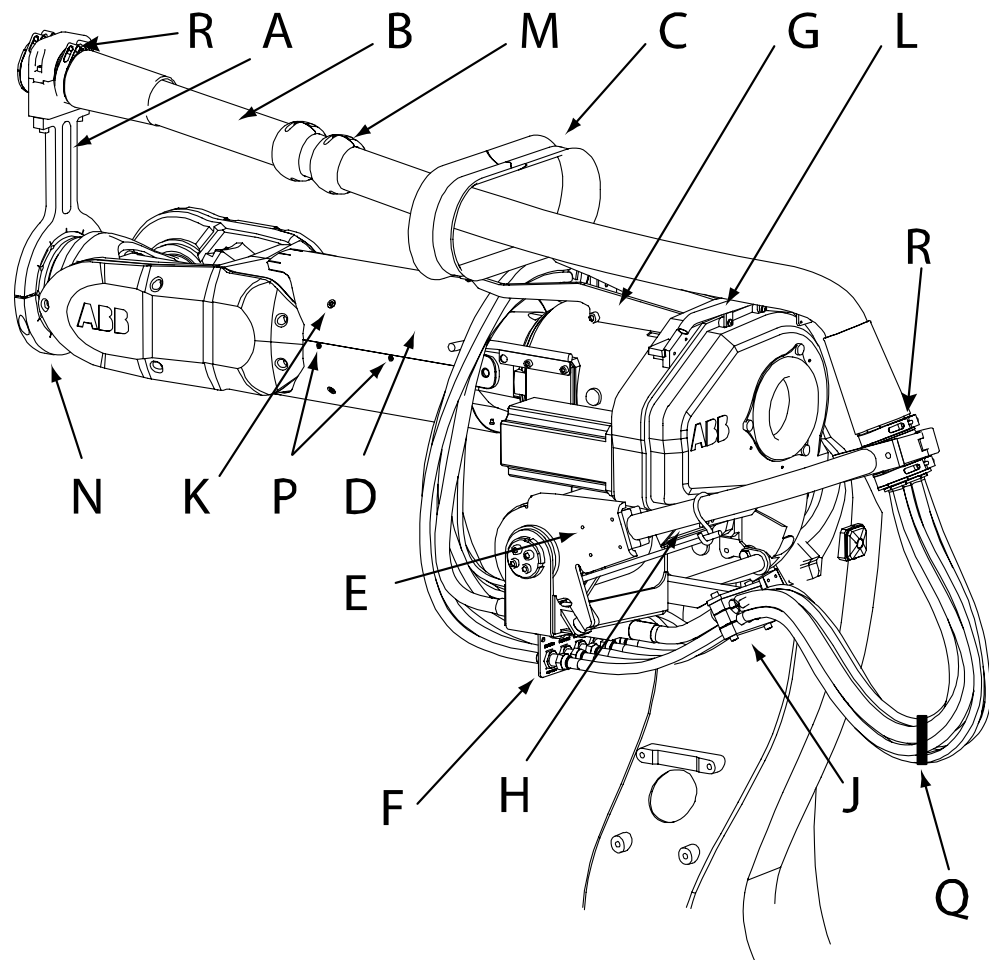

xx0300000004

A	Proc cable support, axis 6
B	Hose package
C	Hose support
D	Arm protection, two halves
E	Retracting unit
F	Connection plate, ax3, proc
G	Brackets for hose support
H	Attachment point below gearbox 4
J	Cable retainer
K	Arm protection attachment screws
L	Rear hose support
M	Protection sleeves
N	Lower half of proc cable support, axis 6
P	Screws securing the arm protection halves to each other

3 Maintenance

3.3.2. Preventive inspection, DressPack upper arm

Q	Velcro strap
R	Slide sleeves

Required equipment

Equipment	Spare part no.	Art. no.	Note
Standard Toolkit, DressPack/SpotPack		3HAC 17290-7	The contents are defined in section Standard toolkit!



WARNING!

Please observe the following before commencing any work on the manipulator:

- Turn off all electric power supplies!

Inspection - Manipulator standing still

The procedure below details how to inspect the DressPack upper arm when the manipulator is not in motion.

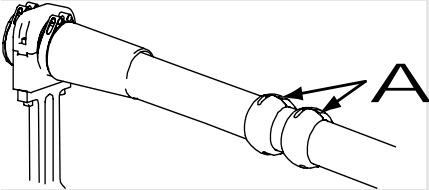
Step	Action	Note/Illustration
1.	Check that the DressPack is not contaminated.	If required, clean as detailed in section Cleaning, DressPack upper arm on page 96.
2.	Check that all bolts are fastened.	Recommended tightening torques are specified in section Screw joints on page 13.
3.	Check the position and state of the protection sleeves. Position these where they prevent the protection hose from rubbing against manipulator upper arm as much as possible. If required, additional protection sleeves may be fitted.	 <p>xx0300000221</p> <p>Parts:</p> <ul style="list-style-type: none"> • A: Protection sleeves <p>Make a note of where the protection sleeves were positioned to facilitate replacing them in the future. If required, replace the protection sleeves.</p>
4.	Make sure all cable straps are tight enough to prevent the cable package from moving in any undesired way.	
5.	Make sure that the cable package is properly connected at the connection plate, axis 3 on the rear of the upper arm as well as at the tool on the manipulator turning disk.	
6.	Check that all connections are safely made and that there are no leaks.	Retighten if necessary.

3.3.2. Preventive inspection, DressPack upper arm

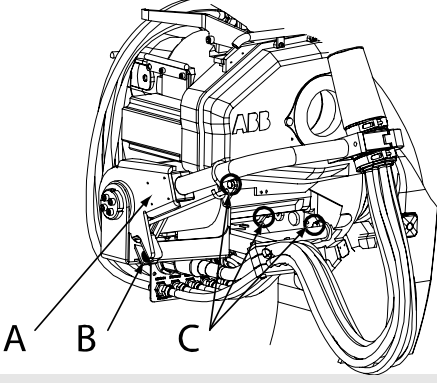
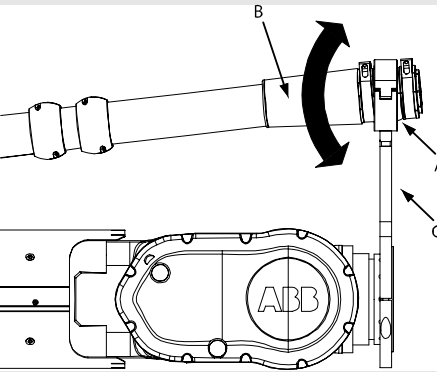
Step	Action	Note/Illustration
7.	Make sure the <i>hose package</i> is not cracked or damaged in any other way.	Shown in the figure in section Location of DressPack upper arm on page 85.
8.	Inspect the rubber damper. Make sure it is not chipped or damaged in any other way.	 <p>xx030000055</p> <p>Parts:</p> <ul style="list-style-type: none"> • A: Retracting unit • B: Damper • C: Retracting arm attachment screws <p>If required, replace the damper as detailed in the Replacement of damper on page 114.</p>
9.	Make sure the sliding surfaces of the slide sleeve has not been damaged or show excessive wear. Check this with normal hand force: grab hold of the package and pull and turn to make sure that the package is free to slide. If the slide sleeves are too worn: 1. disassemble and clean! 2. replace! Always make sure that the sliding sleeves are clean! If they are dirty, clean them!	 <p>xx0300000199</p> <p>Parts:</p> <ul style="list-style-type: none"> • A: Slide sleeve slide surface • B: Hose reinforcement • C: Proc cable support axis 6 <p>A damaged surface may potentially prevent the cable package from rotating, thus causing excessive wear. Cleaning agent is specified in section Required equipment on page 86. If required, replace the slide sleeves as detailed in the Replacement of slide sleeves on page 118 chapter.</p>

3 Maintenance

3.3.2. Preventive inspection, DressPack upper arm

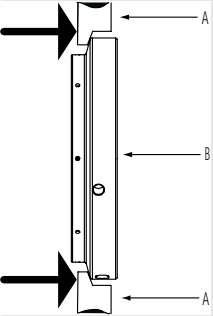
Step	Action	Note/Illustration
10	Check that the proc cable support axis 6 is fully pushed forward against the turning disc axis 6.	<p>If needed, adjust tightening torque as specified in section Screw joints on page 13.</p>  <p>xx0400001040</p> <p>Parts:</p> <ul style="list-style-type: none"> • A: Proc cable support axis 6 • B: Turning disc axis 6
11	Visually inspect the <i>hose reinforcement</i> to make sure there are no cracks or other damage.	<p>Shown in the figure above! If required, replace the hose reinforcement as detailed in the Replacement of hose reinforcement on page 116 chapter.</p>
12	Check all cable clamps securing the process cable package and protective hose for tightness.	<p>Tightening torques are specified either in the Installation chapter or in section Screw joints on page 13.</p> <p>Tightening torques are specified in:</p> <ul style="list-style-type: none"> • Installation chapter (non-standard tightening torques) • standard tightening torque table (standard tightening torques)

Inspection - Reduced speed

The following procedure details how to inspect the DressPack upper arm when the manipulator is moving in reduced speed.



WARNING!

A manipulator in motion is dangerous and may cause severe personal injuries, if safety procedures are not followed. Hence, all work must be performed outside the manipulators working range and outside the manipulators safety area.

Secure the following before work starts:

- Check that all emergency stops are fully functional.
- Close and activate all safety equipment (safety gates and/or safety curtains etc.).

Step	Action	Note/Illustration
1.	Make sure that no hoses or cables, or parts thereof, touch any part of the manipulator structure in a way that may cause wear.	
2.	Make sure all cables and hoses move smoothly together during operation and that no part of the cable package moves in a different pattern.	

Inspection - Full speed

The following procedure details how to inspect the DressPack upper arm, when the manipulator is moving in full speed.

When the robot program is running, the movement of the retracting unit shall be smooth, but still strong enough to retract the hose package without excessive force.



WARNING!

A manipulator in motion is dangerous and may cause severe personal injuries, if safety procedures are not followed. Hence, all work must be performed outside the manipulators working range and outside the manipulators safety area.

Secure the following before work starts:

- Check that all emergency stops are fully functional.
- Close and activate all safety equipment (safety gates and/or safety curtains etc.).

3 Maintenance

3.3.2. Preventive inspection, DressPack upper arm

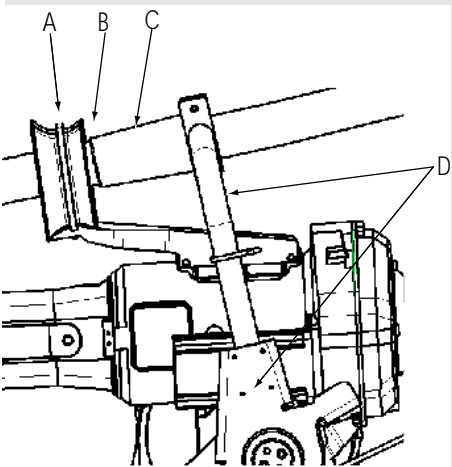
Step	Action	Note/Illustration
1.	Check that the hose reinforcement isn't moving into the hose support more than a few millimeters.	 <p>xx0400001008</p> <p>Parts:</p> <ul style="list-style-type: none">• A: Hose support• B: This shows the maximum forward position of the retracting unit• C: Hose reinforcement• D: Retracting unit
2.	Make sure that no hoses or cables, or parts thereof, touch any part of the manipulator structure (or something in the vicinity of it) in a way that may cause wear.	
3.	Make sure all cables and hoses move smoothly together during operation and that no part of the cable package moves in a different pattern.	

3.3.3. Preventive inspection of water and air unit

Required equipment

Equipment	Spare part no.	Art. no.	Note
Standard Toolkit, DressPack/SpotPack		3HAC 17290-7	The contents are defined in section Standard toolkit!
Other tools and procedures may be required. See references to these procedures in the step-by-step instructions below.			These procedures include references to the tools required.

General inspection

The procedure details how to perform a general inspection of the water and air unit.

Step	Action	Info/Illustration
1.	Check that the water and air unit is not contaminated.	Clean if required as detailed in section Cleaning, water and air unit on page 98.
2.	Check that all bolts are fastened.	Recommended tightening torques are specified in section Screw joints on page 13.
3.	Check that all connections are safely made and that there are no leaks.	Retighten if necessary.

Inspection, air supply circuit

The procedure below details how to inspect the air supply circuit.

3 Maintenance

3.3.3. Preventive inspection of water and air unit

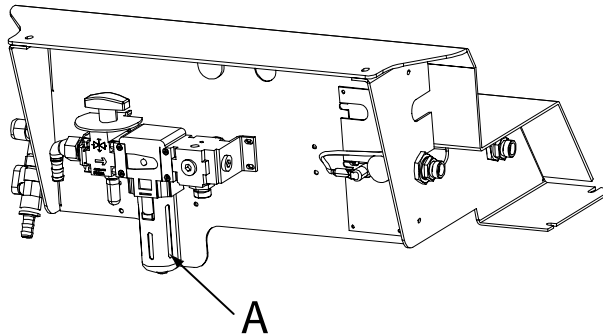

xx0300000180

A Air filter

Step	Action	Note/Illustration
1.	<p>Check if there is water in the filter receptacle. Normally the filter receptacle is drained automatically in case of a fall of air-pressure.</p> <p>It is also possible to drain the filter receptacle manually. This is done by pressing a small pin at the bottom of the air filter unit.</p> <p>If there is no fall of pressure in the air system, there will be no automatic draining of the system. In this case manual draining is necessary.</p>	<p>If there is a lot of water in the filter receptacle, this is a sign that the supplied air consists of too much water. Steps must be taken to correct this problem!</p>
2.	<p>Check that there is no leakage.</p>	<p>If necessary retighten.</p>
3.	<p>Check the condition of the air filter.</p>	<p>If needed replace the air filter. See Replacement of air filter element on page 145 !</p> <p>Normally the filter should be replaced after one year of use.</p>

Inspection, water in and water return circuit

The procedure below details how to inspect the water in and water return circuit.

3.3.3. Preventive inspection of water and air unit

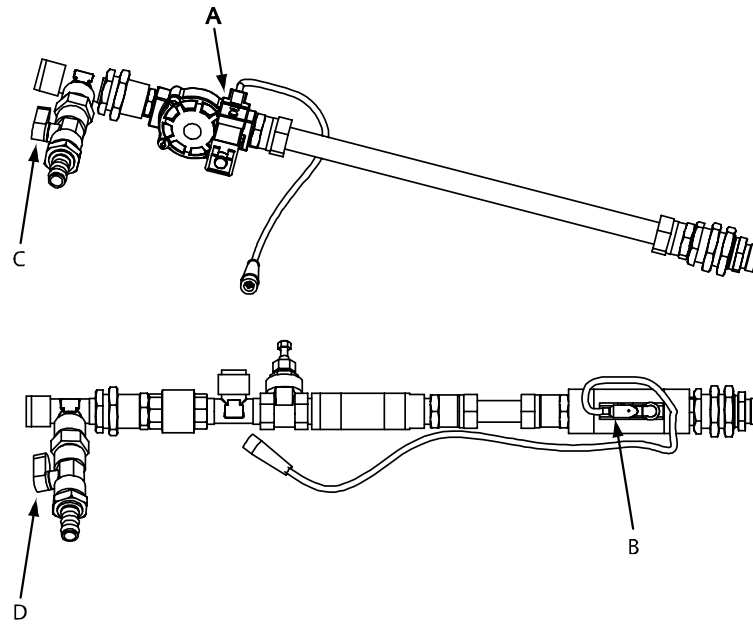

xx0300000179

A	Water valve (on water-in circuit).
B	Flow switch (on mechanical water-return circuit). Digital switch available as option.
C	Hand-operated ball valve (water inlet).
D	Hand-operated ball valve (water outlet).

Step	Action	Note/Illustration
1.	Open the hand-operated ball valve for water inlet.	
2.	Open water valve on water in-circuit.	
3.	Close the hand-operated ball valve for water outlet.	
4.	While the system is under pressure, check that there are no leaks.	If necessary, retighten!
5.	Reset the system.	

3 Maintenance

3.3.4. Preventive inspection of power unit

3.3.4. Preventive inspection of power unit

Location of power unit

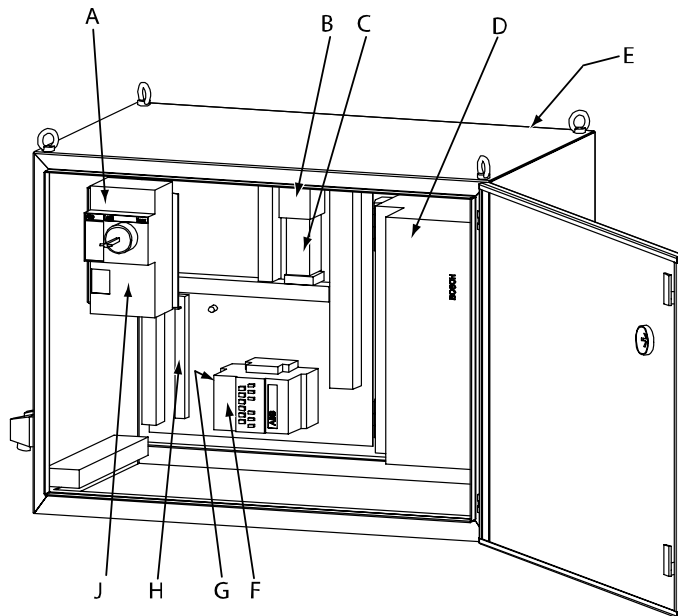

xx0300000181

A	Circuit breaker
B	Fuse terminal
C	Mini contactors (Part of option: "Contactor for welding power")
D	Welding timer
E	Fan unit (Available as option). Placement at the back of the power unit.
F	Welding contactor (Part of option: "Contactor for welding power")
G	Surge suppressor (Part of option: "Contactor for welding power"). Placement behind Welding contactor.
H	Earth bar
J	Earth fault protection (Available as option). Placement varies depending on version (AC or MFDC). This illustration shows placement of AC.

Required equipment

Equipment	Spare part no.	Art. no.	Note
Standard toolkit, DressPack/SpotPack		3HAC 17290-7	The contents are defined in section Standard toolkit!
Multimeter			For measuring resistance
Other tools and procedures may be required. See references to these procedures in the step-by-step instructions below.			These procedures include references to the tools required.

General inspection

The procedure details how to perform a general inspection of the power unit, i.e. the inspection not pertaining to any particular part.

Step	Action	Info/Illustration
1.	Check that the power unit is not contaminated. Especially check the fans and the welding guard for contaminants.	Clean if required.
2.	Check that all bolts are fastened.	Recommended tightening torques are specified in section Screw joints on page 13.
3.	Check that all connections are safely made and that no connectors are loose.	Retighten if necessary.

Inspection, contactor, fuses and circuit breaker

The procedure below details how to inspect contactor, fuses and circuit breaker in power unit.

Step	Action	Info/Illustration
1.	Check settings.	See Appendix!
2.	Check that the contactor is working.	Secure the function of the contactor.
3.	Check fastening of fuse strips .	
4.	Check function of circuit breaker .	
5.	Check cable connections .	

Inspection, earth fault unit

The earth fault unit is not a standard feature of the Power Unit! This instruction details how to inspect the optional earth fault unit fitted by ABB Robotics. Other earth fault unit fitted by others require inspection as specified by that manufacturer respectively.

The procedure below details how to inspect the ABB Robotics earth fault unit.

Step	Action	Note/Illustration
1.	Test the function of the earth fault unit by pressing the button marked "TEST". The unit should trip causing the power supply to be interrupted.	If the result of the function test is not satisfactory, the earth fault switch should be replaced. This is detailed in section Replacement of earth fault protection on page 150.

Inspection, fan unit

Fan unit is an option.

The procedure below details how to inspect the fan unit.

Step	Action	Note/Illustration
1.	Check the function of the fan unit.	Listen for abnormal sounds.
2.	Inspect the fan unit.	If necessary, clean!

3 Maintenance

3.4.1. Cleaning, DressPack upper arm

3.4 Cleaning activities

3.4.1. Cleaning, DressPack upper arm

Location

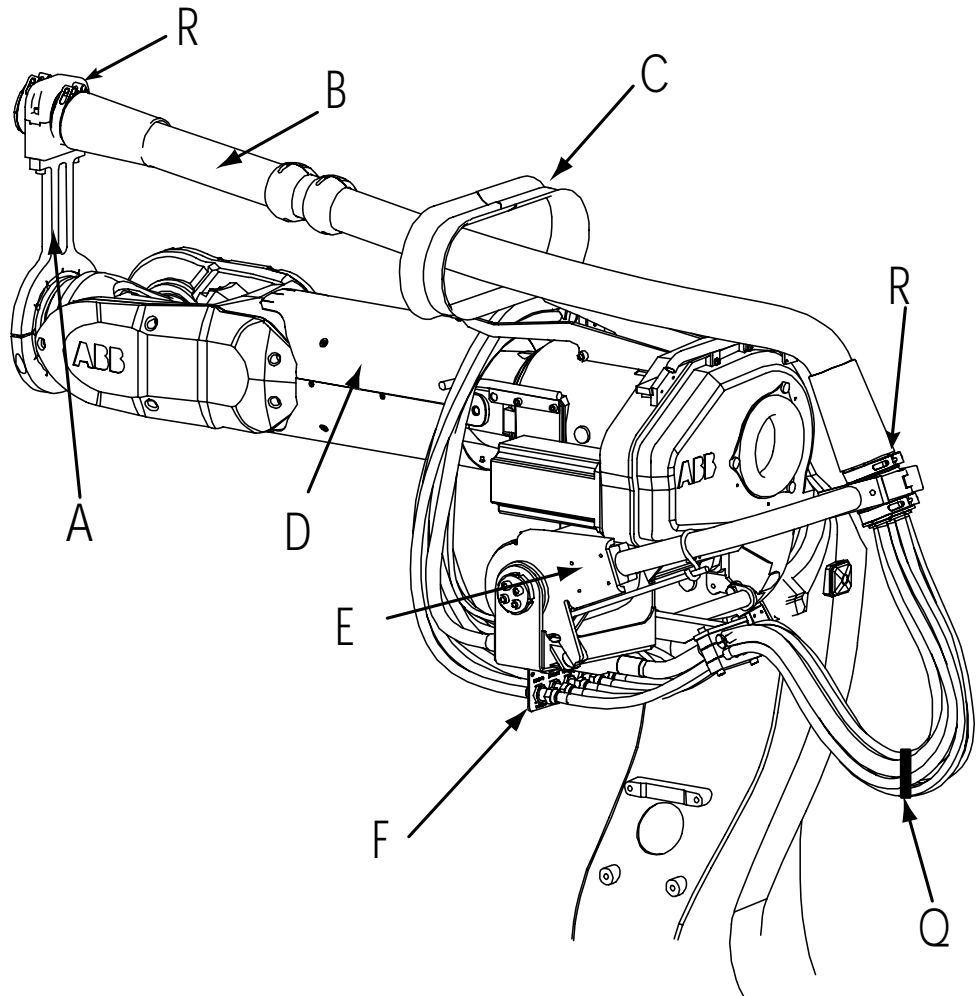

xx0400001004

A	Proc cable support, axis 6
B	Hose package
C	Hose support
D	Arm protection, two halves
E	Retracting unit
F	Connection plate, axis 3 proc
Q	Slide sleeves

Required equipment

Equipment	Spare part no.	Art. no.	Note
Standard Toolkit, DressPack/SpotPack		3HAC 17290-7	The contents are defined in section Standard toolkit!
Dry rag and medium soft brush			For cleaning the protective hose ribs

Cleaning

The procedure below details how to clean the DressPack upper arm.

Step	Action	Note/Illustration
1.	Clean the DressPack upper arm exterior, in order to avoid filling up the spaces between the ribs with debris. Make sure to clean any areas where any hoses bend or rub against the manipulator. If the harness is not cleaned sufficiently, breakage of the protective hose may result.	Only use equipment and cleaning agents as specified in section " Required equipment " on page 83" above!
2.	Clean the slide sleeves of any sort of contamination.	

3 Maintenance

3.4.2. Cleaning, water and air unit

3.4.2. Cleaning, water and air unit

Location

The water and air unit is located as shown in the figure below.

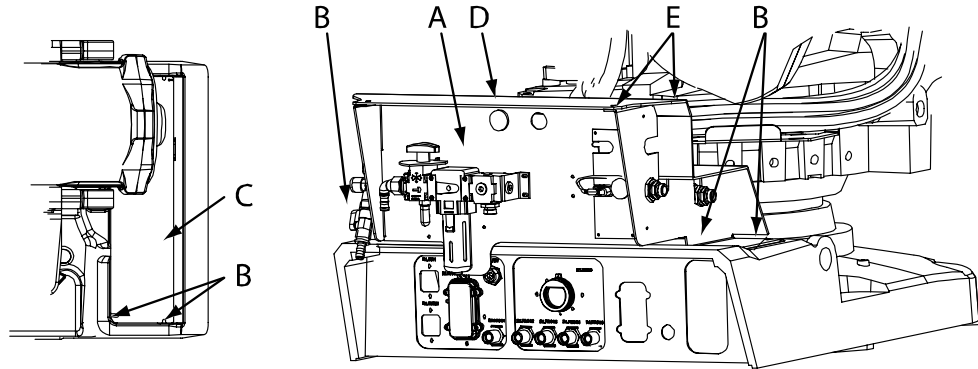

xx0300000144

A	Water & Air unit
B	Unit attachment screws (4 pcs)
C	Top rear cover
D	Water & Air unit, top cover
E	Attachment screws, water and air unit, top cover (4 pcs)

Required equipment

Equipment	Spare part no.	Art. no.	Note
Dry rag			For cleaning water and air unit.

Cleaning, air filter

The procedure below details how to clean the air filter of the water and air unit.

Step	Action	Info/Illustration
1.	Turn off the hand operated air valve and let the air pressure leak out.	
2.	Remove the black protective cover.	This is done by pushing down the spring latch and turning the protective cover 1/8 rev to the left.
3.	Pull the protective cover downwards.	
4.	Remove the filter receptacle.	This is done by turning it 1/8 rev. to the left and then by pulling it downwards.
5.	Clean the receptacle with a rag.	Do not expose filter receptacle to solvents! Use soap and water only!
6.	Change the air filter element if needed.	See section Replacement of air filter element on page 145!

4 Repairs

4.1. Introduction

General

This chapter contains information on how to repair the equipment in question, i.e. how to replace the parts and sub-assemblies found in the Spare Parts section for the same equipment.

4 Repairs

4.2.1. Disassembly of DressPack upper arm

4.2 DressPack upper arm

4.2.1. Disassembly of DressPack upper arm

Location of DressPack upper arm

This section details how to disassemble a generic DressPack upper arm. The actual work may differ due to the number of cables and hoses, the type of connectors etc. However, if differences are distinguishable, these are pointed out in the procedure description.

All work concerning the disassembly of DressPack Upper arm harness is detailed below in section *Disassembly of weld power connector* on page 104 and is to be performed on a work bench. Before the disassembly of the DressPack Upper arm harness, it must be removed from the manipulator. How to remove the Upper arm harness from the manipulator is detailed in section *Removal of the upper arm harness from the manipulator* on page 101.

The DressPack upper arm is located as shown in the figure below.

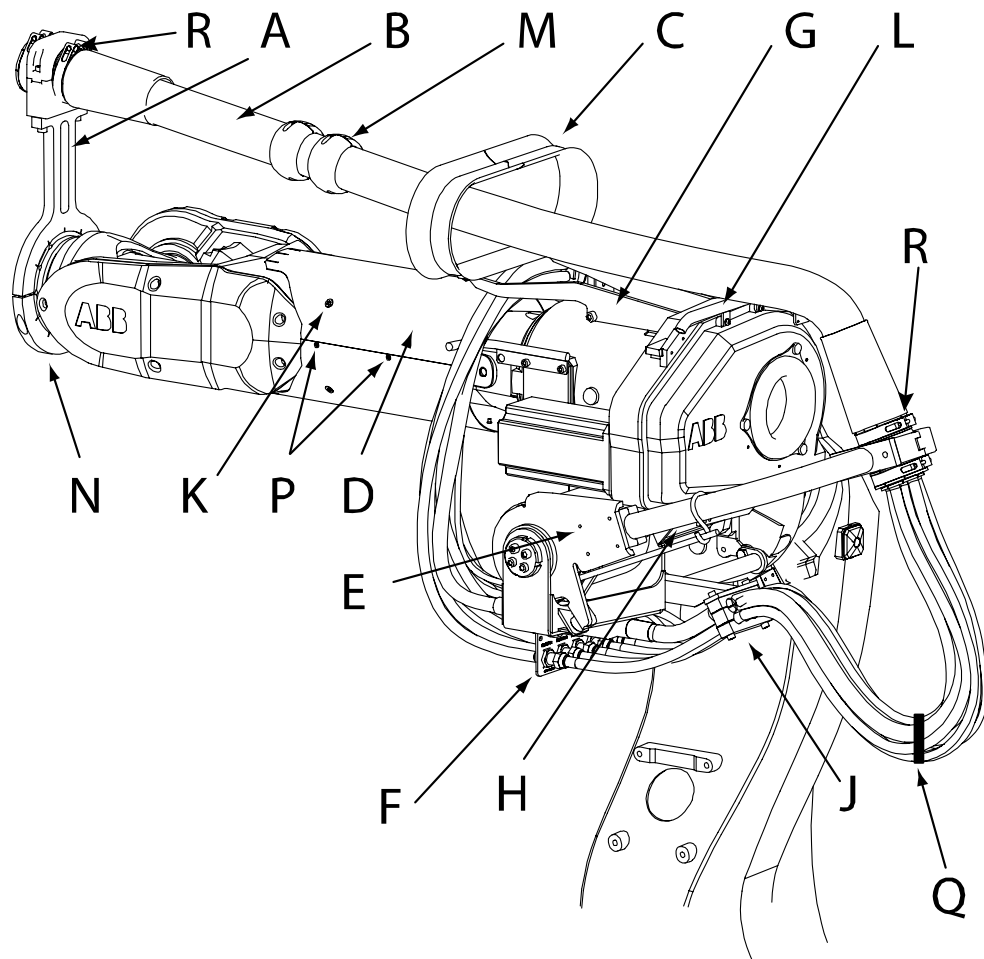

xx030000004

A	Proc cable support, axis 6
B	Hose package
C	Hose support

D	Arm protection, two halves
E	Retracting unit
F	Connection plate, ax3, proc
G	Brackets for hose support
H	Attachment point below gearbox 4
J	Cable retainer
K	Arm protection attachment screws
L	Rear hose support
M	Protection sleeves
N	Lower half of proc cable support, axis 6
P	Screws securing the arm protection halves to each other
Q	Velcro strap
R	Slide sleeves

Required equipment

Equipment, etc.	Spare part no.	Art. no.	Note
Standard Toolkit, DressPack/SpotPack		3HAC 17290-7	The contents are defined in section Standard toolkit!
Clean cotton rag			For cleaning the cable/hose retainers, cables and hoses.
Protective plastic			To protect the connector pins during disassembly.
Other tools and procedures may be required. See references to these procedures in the step-by-step instructions below.			These procedures include references to the tools required.
Circuit Diagram		3HAC 17669-2	DressPack for IRB 6600, 6650 and 7600 using <i>pneumatic</i> welding gun
Circuit Diagram		3HAC 17669-1	DressPack for IRB 6600, 6650 and 7600 using <i>servo</i> welding gun

Removal of the upper arm harness from the manipulator

The procedure below describes how to remove the upper arm harness from the manipulator, before it is disassembled.

The illustration below shows the position of the retracting unit when it is in its rear position, resting against the damper. See "C" below!

4 Repairs

4.2.1. Disassembly of DressPack upper arm

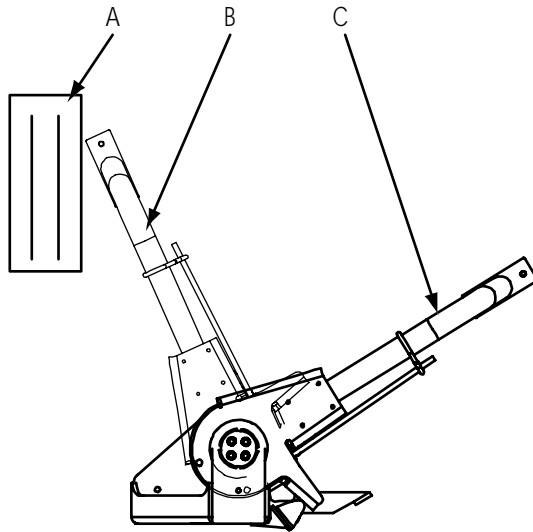

xx030000222

Parts:

- A: Hose support
- B: Retracting unit in max *forward* position
- C: Retracting unit in max *backward* position



WARNING!

Warning!

The retracting unit pulls the hose package backwards! Hence, in order to avoid accidents, the robot must be positioned in a way that the arm of the retracting unit is placed in its rear position. The arm *must* rest on the damper before disassembly of the upper arm harness starts!

Step	Action	Info/Illustration
1.	Turn off the water and air supply	
2.	Disconnect the hoses of the upper arm harness at axis 6	
3.	Disconnect the hoses of the upper arm harness at connection plate axis 3	
4.	Disconnect the signal contact at axis 6	
5.	Disconnect the weld contact at axis 6	
6.	Disconnect the signal contact at connection plate axis 3	
7.	Disconnect the weld contact at connection plate axis 3	
8.	Dismount the cable retainer from the retracting unit. The cable retainer shall not be removed from the harness.	Two M8x16 screws at the rear of the cable retainer
9.	Open the ball joint housing of the Proc cable support, axis 6	

Step	Action	Info/Illustration
10	Open the ball joint housing of the retracting unit	
11	Push the upper arm harness through the hose support	

Disassembly of the upper arm harness

The procedure below details how to disassemble the upper arm harness.

All work detailed below is to be performed on a work bench!

CAUTION!

The cable packs are sensitive to mechanical damage! They must be handled with care, especially the connectors, in order to avoid damaging them!

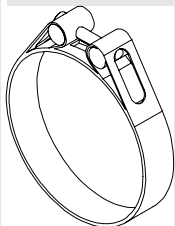
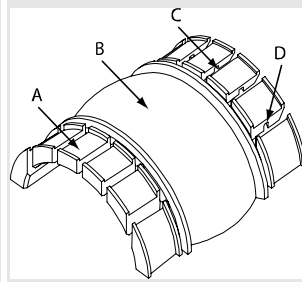

Step	Action	Info/Illustration
1.	Before disassembly starts, mark the position of all cables and hoses in the cable/hose retainer. Use marking tape.	
2.	Remove the front hose clamps and the slide sleeves.	<p>The illustration shows a hose clamp.</p>  <p>xx0300000250</p> <p>The illustrations shows one of the slide sleeve halves. The other is identical.</p>  <p>xx0300000249</p> <p>Parts:</p> <ul style="list-style-type: none"> • A: Hose clamp surface, farthest from the protective hose • B: Slide sleeve slide surface, slightly concave • C: Hose clamp surface, closest to the protective hose • D: Groove for locking the hose reinforcement rib

4 Repairs

4.2.1. Disassembly of DressPack upper arm

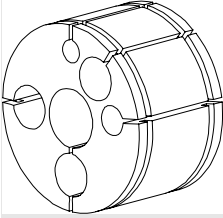
Step	Action	Info/Illustration
3.	Remove the front cable/hose retainer by gently pulling the cables/hoses out. Holes not used in the cable/hose retainer are filled with fillers. NOTE! Save these fillers. They are needed in order to get a proper function of the cable/hose retainer.	<p>The illustration shows a generic retainer. The number of cable/hose holes differ between applications.</p>  <p>xx0300000246</p>
4.	Carefully clean the cable/hose retainer by wiping it clean with a rag.	<i>Do not</i> use any detergent or solvent!
5.	Remove the power sockets from the welding power connector.	Only in applications where a weld power cable is used, i.e. <i>not MH</i> applications! Detailed in section Disassembly of weld power connector on page 104.
6.	Remove the signal sockets from the signal connector	
7.	Gather all connector pins and nipples and gently wrap them in protective plastic.	To facilitate reassembly, we recommend that each conductor is wrapped separately.
8.	Gently, pull all cables/hoses out of the protective hose.	Order: 1. Weld power cable 2. Hoses 3. Signal cables
9.	Do not disassemble the package any further, but just remove the hose/cable to be replaced.	
10	Reassemble the complete package.	Detailed in section Assembly of DressPack upper arm on page 106.

Disassembly of weld power connector

This section details how to disassemble the weld power connector. The actual procedure may differ due to different types of weld power connectors, but the principle is identical.

4.2.1. Disassembly of DressPack upper arm

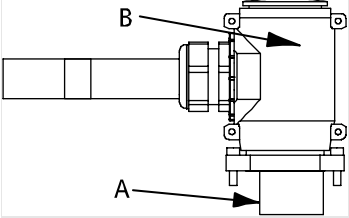
Step	Action	Info/Illustration
1.	Remove the side cover of the weld power connector.	<p>The illustration shows a weld power connector.</p>  <p>xx0400001005</p> <p>Parts:</p> <ul style="list-style-type: none"> • A: Connector sockets (3 pcs) • B: Side cover
2.	Push the three connector sockets into the connector, using extraction tool.	Make sure the cable can slide backwards freely; if not the connector may be damaged when pushing the sockets back.
3.	Remove cable gland.	
4.	Wrap the connector sockets with protective plastic in order to avoid damaging them.	

4 Repairs

4.2.2. Assembly of DressPack upper arm

4.2.2. Assembly of DressPack upper arm

Location of DressPack upper arm

This section details how to assemble a generic DressPack upper arm. The actual work may differ due to the number of cables and hoses, the type of connectors etc. However, if differences are distinguishable, these are pointed out in the procedure description.

All work detailed below is to be performed on a work bench. How to remount the DressPack at the manipulator is detailed in section *Installation, DressPack upper arm attachments* on page 39.

Also assumed is that the DressPack has been disassembled as detailed in section *Disassembly of DressPack upper arm* on page 100.

The DressPack upper arm is located as shown in the figure below.

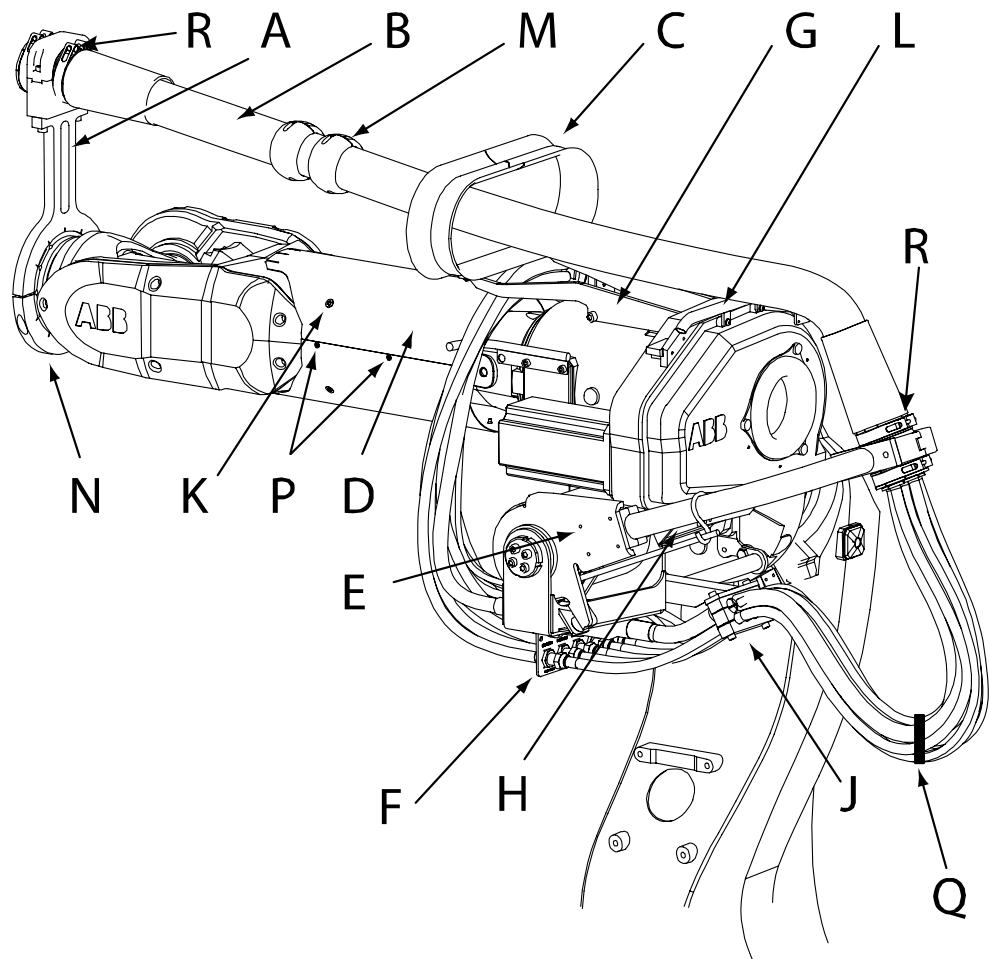

xx030000004

A	Proc cable support, axis 6
B	Hose package
C	Hose support
D	Arm protection, two halves
E	Retracting unit

F	Connection plate, ax3, proc
G	Brackets for hose support
H	Attachment point below gearbox 4
J	Cable retainer
K	Arm protection attachment screws
L	Rear hose support
M	Protection sleeves
N	Lower half of proc cable support, axis 6
P	Screws securing the arm protection halves to each other
Q	Velcro strap
R	Slide sleeves

Required equipment

Equipment, etc.	Spare part no.	Art. no.	Note
Proc cable package	See the Spare parts section!		A number of versions are available.
Cable grease		3HAC 14807-1	40 ml For lubricating the cables/ hoses inside the protective hose.
Protective plastic		-	To protect the connector pins and sockets during installation.
Adhesive masking tape		-	For marking fitting positions
Standard Toolkit, DressPack/SpotPack		3HAC 17290-7	The contents are defined in section Standard toolkit!
Other tools and procedures may be required. See references to these procedures in the step-by-step instructions below.			These procedures include references to the tools required.
Circuit Diagram		3HAC 17669-2	DressPack for IRB 6600, 6650 and 7600 using <i>pneumatic</i> welding gun
Circuit Diagram		3HAC 17669-1	DressPack for IRB 6600, 6650 and 7600 using <i>servo</i> welding gun
Proc cable package assembly drawing		3HAC 16881-2	General for SW
Proc cable package assembly drawing		3HAC 16949-2	General for MH
Connection table		-	

Assembly of the DressPack upper arm

The procedure below details how to assemble the DressPack upper arm.

4 Repairs

4.2.2. Assembly of DressPack upper arm



CAUTION!

The cable packs are sensitive to mechanical damage! They must be handled with care, especially the connectors, in order to avoid damaging them!

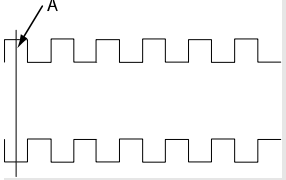
Step	Action	Info/Illustration
1.	Make sure the correct parts are used.	All part numbers are specified in chapter Spare Parts .
2.	Fit the rear cable/hose retainer according to the marking made when disassembling. If the cable or hose is replaced, mark the new one according to the old markings.	Fitting is detailed in section Fitting of cable/hose retainer on page 109. The marking is described in Disassembly of the upper arm harness on page 103.
3.	Fit any strain relief hoses, if such are used. (2 x ½"-hoses)	Make sure these are fitted in the correct holes and that the end plugs are fitted. These are generally only used in MH applications where there are few functional hoses.
4.	Align the cable/hose package making sure each cable/hose is parallel to each other.	If required, rotate each individual hose in the retainer to make use of the natural bend of the hose. Make sure the hose bends coincide with the required bend of the complete package once fitted to the manipulator. If required, use adhesive masking tape to keep the cables hoses together during the assembly. NOTE! All tape must be removed after assembly!
5.	Apply a small amount of <i>cable grease</i> to the cables/hoses using a brush. All surfaces (except 100 mm close to the cable/hose retainer), of <i>each</i> cable or hose should be covered with grease.	Specified in section Required equipment on page 107. Make sure that <i>no grease is applied</i> closer to a hose and cable retainer than 100 mm!
6.	Inspect the protective hose to make sure its ends have been cut correctly.	 <p>xx0300000061 A: Cut the protective hose on top of a ridge</p>
7.	Push hose reinforcements on protective hose.	
8.	Depending on the number of cables/hoses inside the protective hose, there are a few different methods of inserting them.	Detailed in sections Few hoses on page 111, Medium number of hoses on page 112 or Large number of hoses on page 112.
9.	Fit the rear slide sleeves.	Detailed in section Fitting of slide sleeves on page 110.
10	Carefully check that the cable/hose package is not twisted in the front end.	

Step	Action	Info/Illustration
11.	Fit the front cable/hose retainer.	Detailed in section <i>Fitting of cable/hose retainer</i> on page 109.
12	Push any <i>signal cabling</i> 50 mm into the front retainer.	This is done to relieve the cables from tension.
13	Fit the front slide sleeves.	Detailed in section <i>Fitting of slide sleeves</i> on page 110.
14	Remove the protective plastic from the connector pins and water nipples.	
15	Assemble any connectors in the cable ends.	This varies depending on the application. Fit the connector pins as in the Circuit Diagram and Connection table, specified in section <i>Required equipment</i> on page 107.
16	Connect the complete cable/hose package connectors and water nipples.	This varies depending on the application.
17.	To make sure each pin is fitted in the correct position, we strongly recommend that the resistance of each wire is measured from end to end.	Check the wires as in the Circuit Diagram and Connection table, specified in section <i>Required equipment</i> on page 107.

Fitting of cable/hose retainer

This section details how to fit the cable/hose retainers.

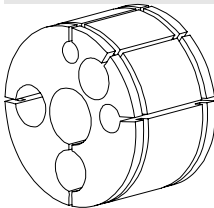
Step	Action	Info/Illustration
1.	Study the assembly drawing. Especially check the recommended lengths and mounting positions of the <i>hose and cable retainer</i> .	<p>The illustration shows a generic retainer. The number of cable/hose holes differ between applications.</p>  <p>xx0300000246</p>
2.	Mark all <i>clamping positions</i> with adhesive masking tape.	Specified on the assembly drawing.
3.	Fit the rear hose and cable retainer as shown in the assembly drawing.	<p>Under <i>no circumstances</i> may any form of lubrication be applied to the retainer! If this should happen by accident, the lubrication must be carefully removed. Use a dry rag to wipe it clean.</p> <p>Make sure it is turned the right way.</p> <p>If required, a pair of heavy pliers may be used to open the cable/hose holes.</p> <p>Empty holes in the cable/hose retainer should be filled with fillers.</p>

4 Repairs

4.2.2. Assembly of DressPack upper arm

Fitting of slide sleeves

This section details how to fit the slide sleeves.

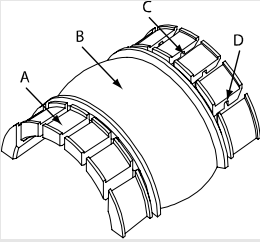
Step	Action	Info/Illustration
1.	Fit the slide sleeves over the protective hose. Make sure they are turned the right way!	<p>The illustration shows one half of a slide sleeve. The two halves are identical.</p>  <p>xx0300000249</p> <p>Parts:</p> <ul style="list-style-type: none">• A: Hose clamp surface, farthest from the protective hose• B: Slide sleeve slide surface, slightly concave• C: Hose clamp surface, closest to the protective hose• D: Groove for locking the hose reinforcement

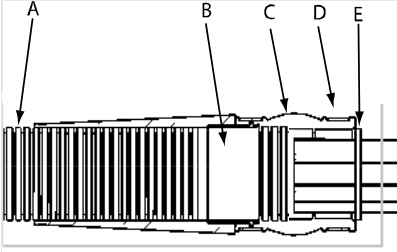
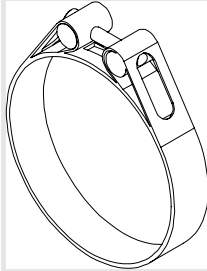
Step	Action	Info/Illustration
2.	<p>This illustration shows the fitting positions of slide sleeves on cable/hose retainer.</p>	<p>The illustration shows a cross section of the slide sleeve.</p>  <p>xx0400001007</p> <p>Parts:</p> <ul style="list-style-type: none"> • A: Protective hose • B: Hose reinforcement • C: Slide sleeves • D: Hose clamp • E: Cable/Hose retainer
3.	<p>Secure the slide sleeves with hose clamps.</p> <p>In applications where a large number of cables/hoses are used, the aluminum cable clamps may be used to compress the entire package.</p> <p>The slide sleeves are correctly tightened when a fully tightened aluminum cable clamp (e.g. on the retracting unit) and the Proc cable support axis 6 allows some swivelling.</p>	<p>Make sure both clamps face the same way! Make sure the gaps between the slide sleeve halves are close to identical and <i>do not coincide</i> with the vertical cuts in the hose and cable retainer!</p> <p>The illustration shows a hose clamp.</p>  <p>xx0300000250</p>

Few hoses

This section details how to insert the cables and hoses into the protective hose in cases where there are only a few cables/hoses.

	Action	Info/Illustration
1.	<p>Gather all connector pins and water nipples and gently wrap them in protective plastic.</p>	
2.	<p>Keeping the cable/hose package together, gently insert the package into the protective hose.</p>	
3.	<p>Remove the protective plastic from the connector pins and water nipples.</p>	
4.	<p>Proceed where you left off above!</p>	

4 Repairs

4.2.2. Assembly of DressPack upper arm

Medium number of hoses

This section details how to insert the cables and hoses into the protective hose in cases where there are *more* than a few cables/hoses.

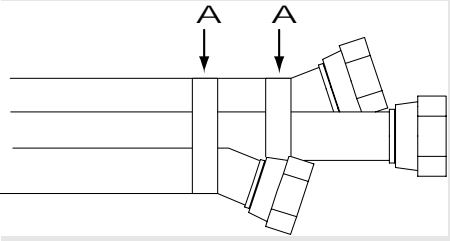
Step	Action	Info/Illustration
1.	Try to insert the cables/hoses as detailed in section Few hoses on page 111. If the complete package is too wide, proceed below:	
2.	Tape the cables/hoses together with the connectors/nipples staggered.	 <p>xx030000253</p> <p>Parts:</p> <ul style="list-style-type: none"> A: Adhesive tape
3.	Gently insert the package into the protective hose.	
4.	Remove the protective plastic from the connector pins and water nipples.	
5.	Proceed where you left off above!	

Large number of hoses

This section details how to insert the cables and hoses into the protective hose in cases where there are a large number of cables/hoses.

Step	Action	Info/Illustration
1.	Try to insert the cables/hoses as detailed in section Medium number of hoses on page 112. If the complete package is too wide, proceed below:	
2.	Cut the minimum amount of nipples from the package.	Cut as close to the nipple as possible. Since the original hose length was correct, this operation may only be performed a minimum number of times on each hose.
3.	Gather the remainder of the connector pins and water nipples and gently wrap them in protective plastic.	
4.	Gently insert the package into the protective hose.	
5.	Gently pull the cut hose through the protective hose.	If required, the protective hose may be squeezed gently to out-of-round to facilitate pulling the hose through.

Step	Action	Info/Illustration
6.	Refit the water nipple on the hose.	
7.	Proceed where you left off above!	

Remounting of upper arm harness on manipulator

The procedure to remount the DressPack upper arm harness on the manipulator, is described in *Installation, DressPack upper arm attachments* on page 39.

4 Repairs

4.2.3. Replacement of damper

4.2.3. Replacement of damper

Location

The damper is located as shown in the figure below.

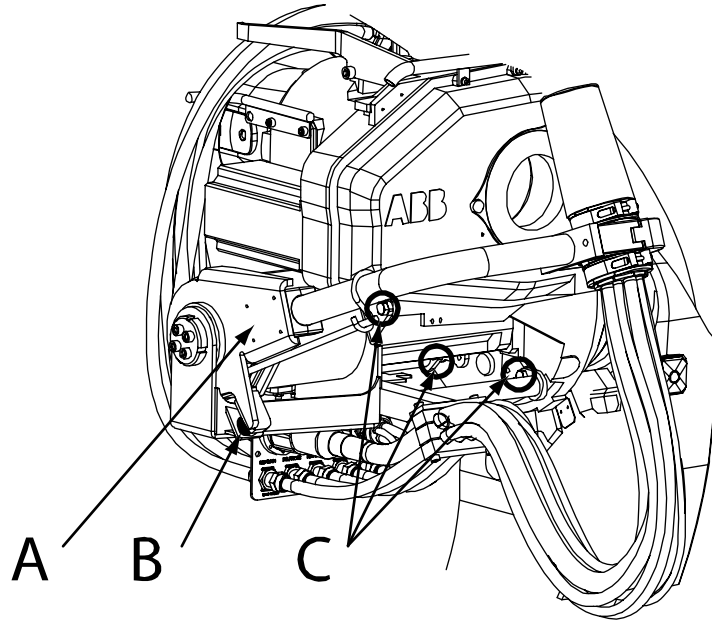

xx030000055

A	Retracting unit
B	Damper
C	Retracting arm attachment screws

Required equipment

Equipment, etc.	Spare part no.	Art. no.	Note
Damper		3HAC 14230-18	
Standard Toolkit, DressPack/SpotPack		3HAC 17290-7	The contents are defined in section Standard toolkit!
Other tools and procedures may be required. See references to these procedures in the step-by-step instructions below.			These procedures include references to the tools required.

Removal

The procedure below details how to remove the damper.

**WARNING!**

Please observe the following before commencing any repair work on the manipulator:

- Motors and gears are HOT after running the robot! Touching the motors and gears may result in burns!
- Turn off all electric power, hydraulic and pneumatic pressure supplies to the robot!
- Take any necessary measures to ensure that the manipulator does not collapse as parts are removed, e.g. secure the lower arm with fixtures if removing motor, axis 2.

Step	Action	Note/Illustration
1.	Pull the retracting unit arm forward by hand to access the damper.	Shown in the figure in section Location on page 114.
2.	Remove the damper by unscrewing the locking nut beneath the damper.	

Refitting

The procedure below details how to refit the damper.

**WARNING!**

Please observe the following before commencing any repair work on the manipulator:

- Motors and gears are HOT after running the robot! Touching the motors and gears may result in burns!
- Turn off all electric power, hydraulic and pneumatic pressure supplies to the robot!
- Take any necessary measures to ensure that the manipulator does not collapse as parts are removed, e.g. secure the lower arm with fixtures if removing motor, axis 2.

Step	Action	Note/Illustration
1.	Pull the retracting unit arm forwards by hand, to access the damper.	Shown in the figure in section Location on page 114.
2.	Fit the damper and secure it with its securing nut beneath the damper.	

4 Repairs

4.2.4. Replacement of hose reinforcement

4.2.4. Replacement of hose reinforcement

Overview

All work detailed below is to be performed on a workbench!

How to remove the dresspack upper arm harness from the manipulator is detailed in section *Removal of the upper arm harness from the manipulator* on page 101

Location of hose reinforcement

The hose reinforcement is located as shown in the figure below.

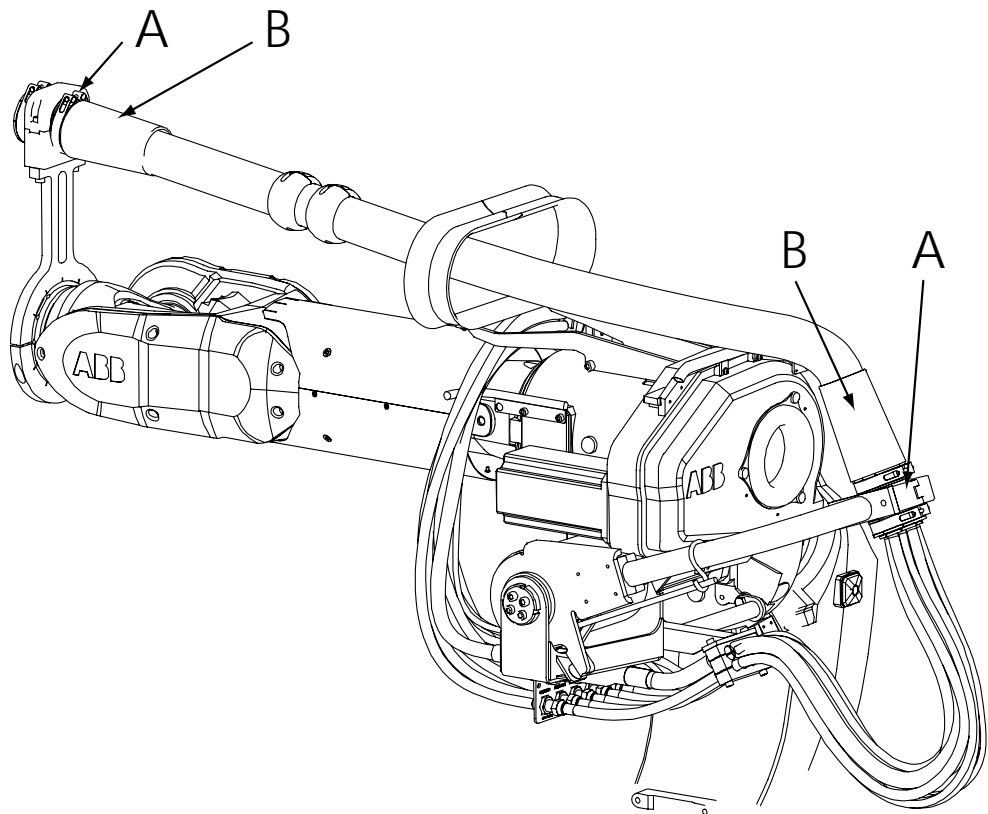

xx0300000259

A	Slide sleeves
B	Hose reinforcement

Required equipment

Equipment, etc.	Spare part no.	Art. no.	Note
Hose reinforcement	3HAC 022194-001		

Equipment, etc.	Spare part no.	Art. no.	Note
Standard Toolkit, DressPack/SpotPack		3HAC 17290-7	The contents are defined in section Standard toolkit!
Other tools and procedures may be required. See references to these procedures in the step-by-step instructions below.		-	These procedures include references to the tools required.

Removal

The procedure below details how to remove the hose reinforcement.

Step	Action	Info/Illustration
1.	Perform the first steps in the procedure "Disassembly the DressPack, upper". This will give access to the slide sleeves.	Detailed in section <i>Disassembly of DressPack upper arm</i> on page 100.
2.	Pull the hose reinforcements off the protective hose.	Make sure that the protective hose is not damaged. If the protective hose is damaged, replace it!

Refitting

The procedure below details how to refit the hose reinforcement.

Step	Action	Info/Illustration
1.	Select the hose reinforcement.	Article number is specified in the <i>DressPack, upper arm, std</i> on page 162 chapter.
2.	Gently push the hose reinforcement onto the protective hose.	Make sure the hose reinforcement rib align with the slide sleeve on assembly.
3.	Perform the last steps in the procedure "Assembly the DressPack, upper".	Detailed in section <i>Assembly of DressPack upper arm</i> on page 106.

4 Repairs

4.2.5. Replacement of slide sleeves

4.2.5. Replacement of slide sleeves

Location of slide sleeves

The slide sleeves are located as shown in the figure below.

All work detailed below is to be performed on a work bench. How to remove the DressPack from the manipulator is detailed in section *Removal of the upper arm harness from the manipulator* on page 101.

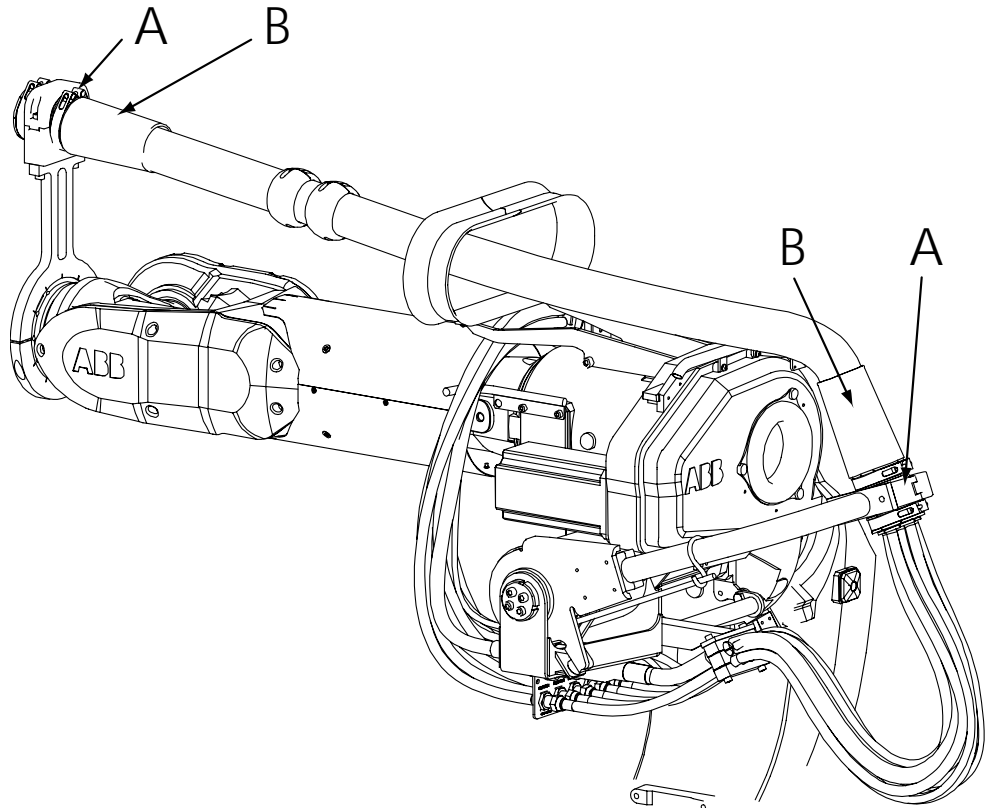

xx030000259

A	Slide sleeves
B	Hose reinforcement

Required equipment

Equipment, etc.	Spare part no.	Art. no.	Note
Slide sleeves		3HAC 16208-1	
Standard Toolkit, DressPack/SpotPack		3HAC 17290-7	The contents are defined in section Standard toolkit!
Other tools and procedures may be required. See references to these procedures in the step-by-step instructions below.		-	These procedures include references to the tools required.

Removal

The procedure below details how to remove the slide sleeves.

Step	Action	Info/Illustration
1.	Perform the first steps in the procedure "Disassembly the DressPack, upper". This will give access to the slide sleeves.	Detailed in section Disassembly of DressPack upper arm on page 100.

Refitting

The procedure below details how to refit the slide sleeves.

Step	Action	Info/Illustration
1.	Perform the last steps in the procedure "Assembly the DressPack, upper".	Detailed in section Assembly of DressPack upper arm on page 106.

4 Repairs

4.2.6. Adjusting the spring tension of the retracting unit

4.2.6. Adjusting the spring tension of the retracting unit

Location of retracting unit

The retracting unit is located as shown in the figure below.

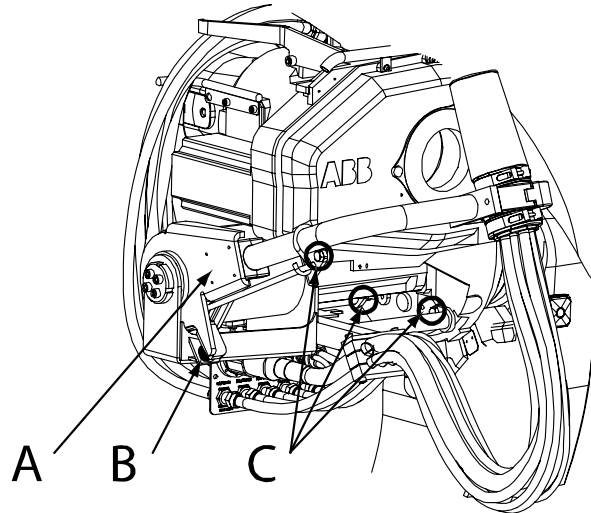

xx030000055

A	Retracting unit
B	Damper
C	Retracting arm attachment screws

Required equipment

Equipment	Spare part no.	Art. no.	Note
Standard tool kit, DressPack/SpotPack		3HAC 17290-7	The contents are defined in section Standard toolkit!
Other tools and procedures may be required. See references to these procedures in the step-by-step instructions below.			These procedures include references to the tools required.

Retracting units

The retracting units for IRB6600 and IRB7600 models are not the same. Illustrations show the retracting unit for IRB6600. The same principles are used for the retracting unit used for IRB7600.

The table below shows the different article numbers of the retracting units.

Art.no	Robot model
3HAC 15960-1	Retracting unit for IRB 6600 .
3HAC 15966-1	Retracting unit for IRB 7600 .

4.2.6. Adjusting the spring tension of the retracting unit

**WARNING!**

The spring inside the retracting unit is under tension! Never disassemble the unit!

Always exercise care when working with the retracting unit!

Reason for adjustment

When adjusted correctly, the retracting unit should use its full working range during operation.

The retracting unit is adjusted to a standard spring tension on delivery ($\frac{3}{4}$ of a revolution). If for any reason, it should be dismantled from the manipulator, the spring tension must be readjusted.

The retracting unit may also be adjusted, whenever needed, to obtain optimal function.

In order to increase the lifetime of the upper arm harness, the tension of the retracting unit should not be higher than necessary.

How to loosen the tensioned spring

The procedure below details how to loosen the tensioned spring of the retracting unit.

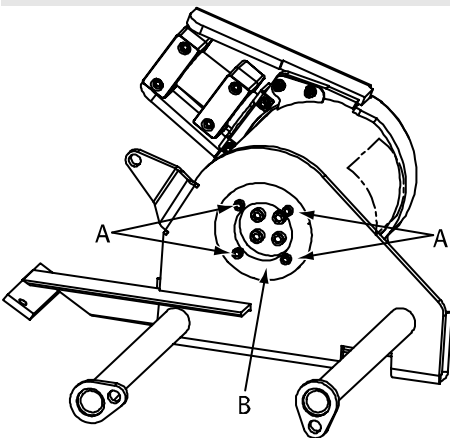
Step	Action	Note/Illustration
1.	NOTE! Before loosening the tensioned spring, the arm of the retracting unit shall be in its rear position (resting against the damper).	
2.	Loosen the four screws, on the outer ring at the back of the retracting unit. See illustration!	<p>Illustration shows position of screws at the back.</p>  <p>xx0400001039</p> <p>Parts:</p> <ul style="list-style-type: none"> • A: Screws • B: Outer ring

4 Repairs

4.2.6. Adjusting the spring tension of the retracting unit

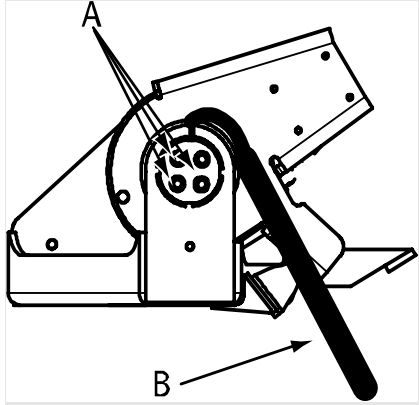
Step	Action	Note/Illustration
3.	Apply the hook wrench (68-75 mm) at the outside of the retracting unit as shown in illustration. See illustration!	Illustration shows position of screws at the front.  xx0400000994 Parts: <ul style="list-style-type: none"> • Screws • Hook wrench
4.	Hold the hook wrench firmly!	
5.	NOTE! Be prepared when performing the following procedure! When loosening the screws, the force of the spring will try to rotate the hook wrench counter clockwise. Be careful!	
6.	Carefully undo the four screws on the outside of the retracting unit, while holding the hook wrench firmly.	
7.	Turn the axis of the retracting unit counter clockwise with the hook wrench until the spring has no tension.	
8.	Now the starting position for setting the tension of the spring.	

Setting up the spring tension

The procedure below details how to set up the spring tension of the retracting unit.

Step	Action	Note/Illustration
1.	Turn the axis of the retracting unit clockwise with the hook wrench $\frac{3}{4}$ of a revolution. This position is the standard setting.	For other settings than standard setting, see table below "Approximate forces with different settings"!
2.	Retighten the four screws on the outside of the retracting unit while holding the axis firmly with the hook wrench.	See illustration above! Tightening torque: 50 Nm \pm 5 Nm
3.	Remove the hook wrench.	

4.2.6. Adjusting the spring tension of the retracting unit

Step	Action	Note/Illustration
4.	Retighten the four screws on the outer ring at the back of the retracting unit.	See illustration above! Tightening torque: 10 Nm \pm 5 Nm
5.	Run the program and confirm that the tension of the retracting unit works as it should. If not, redo the procedure of setting up the spring tension of the retracting unit.	

Recommended tension

The arm of the retracting unit shall "float" a little, when the robot is moving.

The hose reinforcement (the rubber part of the protective hose) should not enter the hose support when the manipulator is running in full speed. See "B" in illustration below!

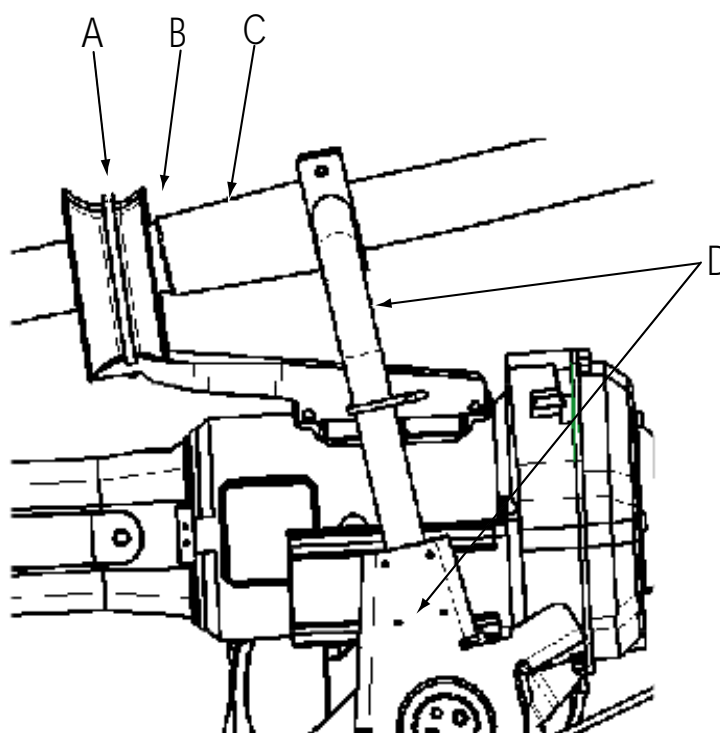

xx0400001008

A	Hose support
B	This shows the maximum forward position of the retracting unit
C	Hose reinforcement
D	Retracting unit

Recommended tension of the spring is $\frac{3}{4}$ of a revolution ($\approx 270^\circ$). This tension is optimized for normal length of upper arm harness for spot welding working vertically. This is the tension set on the retracting units on delivery.

Short upper arm harness for material handling working horizontally, may need less tension.

Long upper arm harness on shelf mounted robots, may need a higher tension.

4 Repairs

4.2.6. Adjusting the spring tension of the retracting unit

Approximate forces with different settings

The table below shows the approximate forces with different settings.

Setting	Pull force	Release force
1 rev	150 N	130 N
$\frac{3}{4}$ rev	105 N	85 N
$\frac{1}{2}$ rev	70 N	45 N

NOTE! Never turn the spring more than *one* revolution (=360°)!

4.3 DressPack lower arm

4.3.1. Disassembly of DressPack lower arm

Location of DressPack lower arm

This section details how to disassemble a generic DressPack lower arm. The actual work may differ due to the number of cables and hoses, the type of connectors etc. However, if differences are distinguishable, these are pointed out in the procedure description.

All work concerning the disassembly of the DressPack lower arm harness is detailed below in section *Disassembly of the lower arm harness* and is to be performed on a work bench. Before the disassembly of the DressPack lower arm harness, it must be removed from the manipulator. How to remove the DressPack lower arm from the manipulator is detailed in section *Removal of the lower arm harness from the manipulator*.

The DressPack lower arm is located as shown in the figure below.

4 Repairs

4.3.1. Disassembly of DressPack lower arm

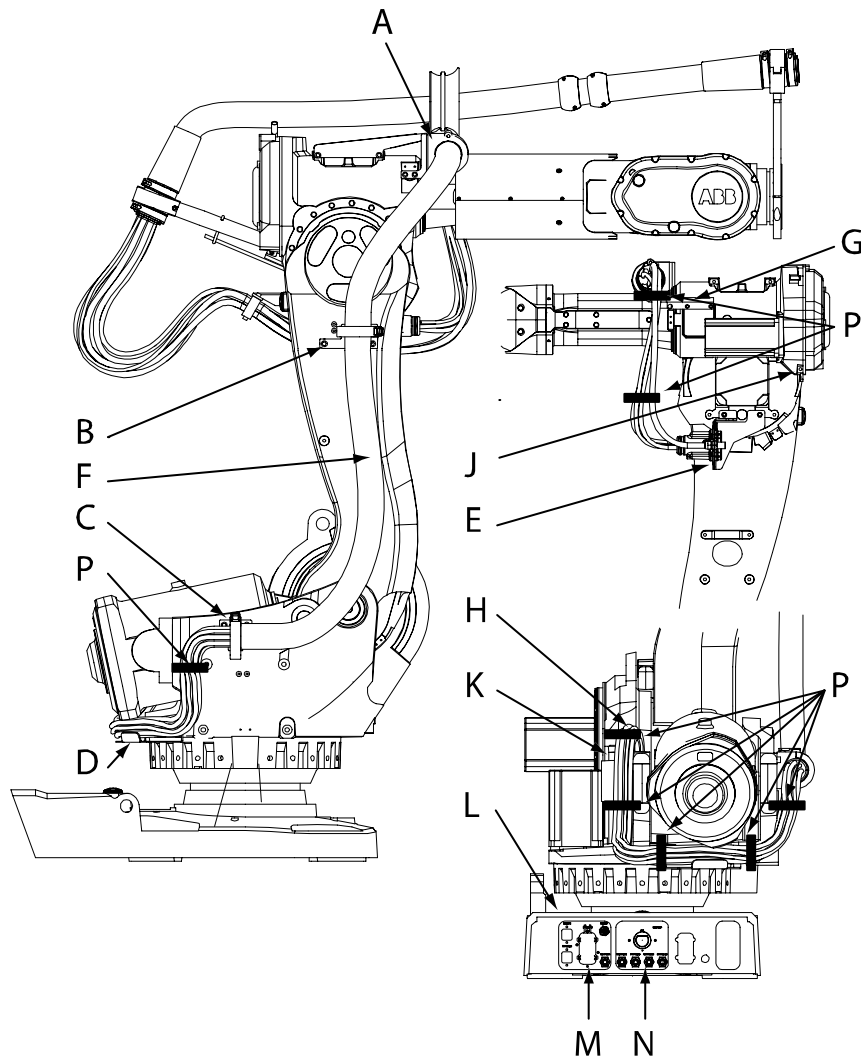

xx030000006

A	Upper proc cable package attachment
B	Mid proc cable package attachment
C	Lower proc cable package attachment
D	Cable conduit
E	Connection plate ax3, proc.
F	Process cable package
G	Cable guide
H	Process cable package attachment at gearbox 1
J	Attachment point below gearbox 4
K	Cable fixing bracket
L	Plate, base (top cover)
M	Plate, customer
N	Plate, proc.
P	Velcro straps (7 pcs)

Required equipment

Equipment, etc.	Spare part no.	Art. no.	Note
Standard toolkit, DressPack/SpotPack		3HAC 17290-7	The contents are defined in section Standard toolkit!
Other tools and procedures may be required. See references to these procedures in the step-by-step instructions below.			These procedures include references to the tools required.
Circuit Diagram		3HAC 17669-2	DressPack for IRB 6600, 6650 and 7600 using <i>pneumatic</i> welding gun
Circuit Diagram		3HAC 17669-1	DressPack for IRB 6600, 6650 and 7600 using <i>servo</i> welding gun

Removal of the lower arm harness from the manipulator

The procedure below details how to disassemble the DressPack lower arm harness from the manipulator.

Step	Action	Info/Illustration
1.	Remove 7 velcro straps securing cables and hoses.	See Location of DressPack lower arm on page 125
2.	Disconnect hoses from the connection plate ax 3 proc.	See Location of DressPack lower arm on page 125
3.	Remove the plate base (top cover) on the manipulator by dismounting its attachment screws.	
4.	Dismantle hoses mounted on plate customer and plate proc.	
5.	Disconnect cables from the connection plate ax 3 proc.	
6.	Dismantle upper proc cable package attachment.	See Location of DressPack lower arm on page 125
7.	Dismantle mid proc cable package attachment.	See Location of DressPack lower arm on page 125
8.	Dismantle lower proc cable package attachment.	See Location of DressPack lower arm on page 125
9.	Dismantle screw securing signal cable/ hose and weld power cable in the hole in gearbox axis 1.	See Location of DressPack lower arm on page 125
10.	Dismantle weld power attachment screws fitting weld power cable to plate proc on weld connector bracket.	See Installation, DressPack lower arm attachments on page 29
11.	Dismantle signal cable mounted on plate customer and plate proc.	See Installation, DressPack lower arm attachments on page 29
12.	Pull lower end of the cable package out through the hole in gearbox axis 1.	

4 Repairs

4.3.1. Disassembly of DressPack lower arm

Disassembly of the lower arm harness

The procedure below details how to disassemble the DressPack lower arm.

CAUTION!

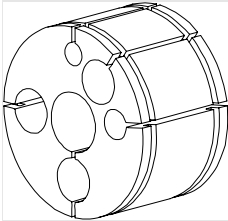

The cable packs are sensitive to mechanical damage! They must be handled with care, especially the connectors, in order to avoid damaging them!

Step	Action	Info/Illustration
1.	Remove the front cable/hose retainer by gently pulling the cables/hoses out.	The illustration shows a generic retainer. The number of cable/hose holes differ between applications.  xx0300000246
2.	Carefully clean the cable/hose retainer by wiping it clean with a rag.	<i>Do not</i> use any detergent or solvent!
3.	Gather all connector pins and nipples and gently wrap them in protective plastic.	To facilitate reassembly, we recommend that each conductor is wrapped separately.
4.	Gently, pull all cables/hoses out of the protective hose.	Order of dismounting: 1. Weld power cable. See instructions below! 2. Hoses 3. Signal cables. See instructions below!
5.	In order to pull out the <i>weld power cable</i> , pins must be dismantled. The cable gland must also be removed.	
6.	In order to pull out the <i>signal cable</i> , the form shroud must be cut away. Then dismantle the pins.	Use hacksaw and a sharp knife to cut away the form shroud. A new form shroud must be used when reassembling the package!
7.	Do not disassemble the package any further, just remove the hose/cable to be replaced.	
8.	Reassemble the complete package.	Detailed in section Assembly of DressPack lower arm on page 129.

4.3.2. Assembly of DressPack lower arm

Location of DressPack lower arm

This section details how to assemble a generic DressPack lower arm. The actual work may differ due to the number of cables and hoses, the type of connectors etc. However, if differences are distinguishable, these are pointed out in the procedure description.

All work detailed below is to be performed on a work bench. How to remove the DressPack from the manipulator is detailed in section *Removal of the lower arm harness from the manipulator* on page 127.

Also assumed is that the DressPack has been disassembled as detailed in section *Disassembly of DressPack lower arm* on page 125.

The DressPack lower arm is located as shown in the figure below.

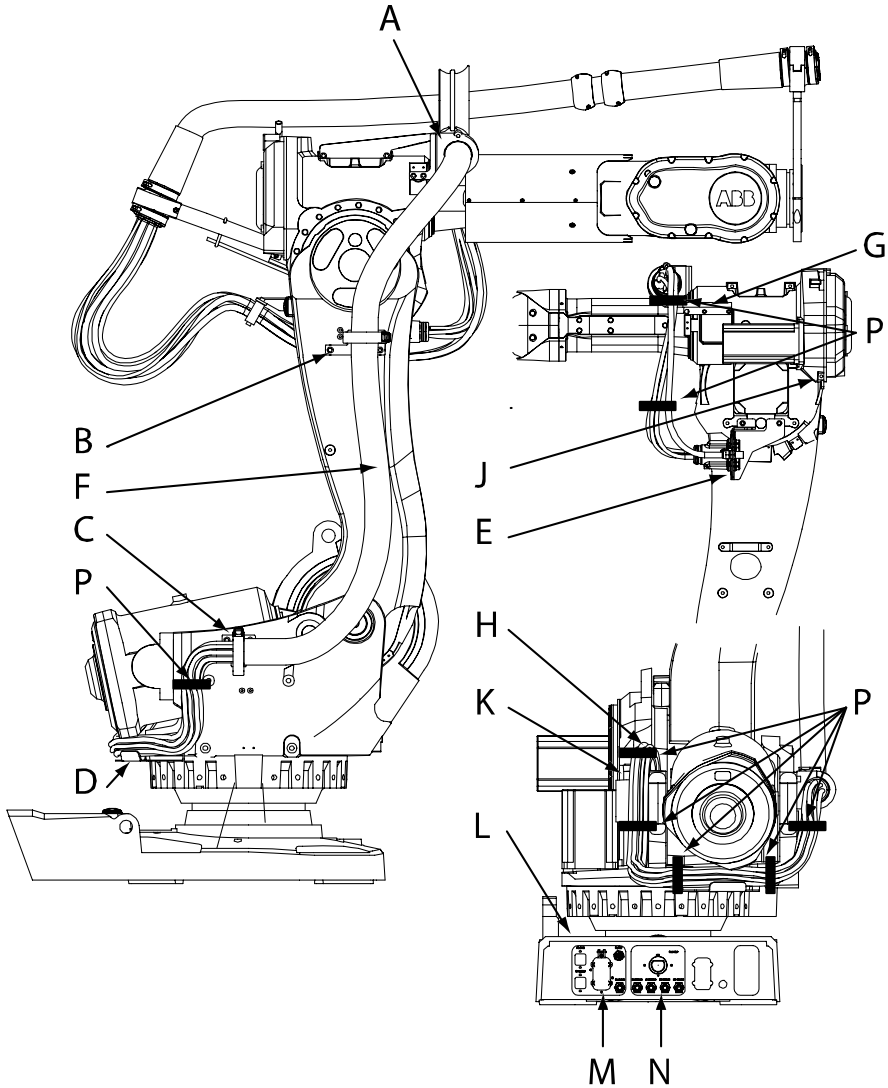

xx030000006

A	Upper proc cable package attachment
B	Mid proc cable package attachment

4 Repairs

4.3.2. Assembly of DressPack lower arm

C	Lower proc cable package attachment
D	Cable conduit
E	Connection plate ax3, proc.
F	Process cable package
G	Cable guide
H	Process cable package attachment at gearbox 1
J	Attachment point below gearbox 4
K	Cable fixing bracket
L	Plate, base (top cover)
M	Plate, customer
N	Plate, proc.
P	Velcro straps (7 pcs)

Required equipment

Equipment, etc.	Spare part no.	Art. no.	Note
Proc cable package	See the Spare parts section!		A number of versions are available.
Cable grease		3HAC 14807-1	40 ml For lubricating the cables/hoses inside the protective hose.
Protective plastic		-	To protect the connector pins during installation.
Adhesive masking tape		-	For marking fitting positions
Standard Toolkit, DressPack/SpotPack		3HAC 17290-7	The contents are defined in section Standard toolkit!
Other tools and procedures may be required. See references to these procedures in the step-by-step instructions below.		-	These procedures include references to the tools required.
Circuit Diagram		3HAC 17669-2	DressPack for IRB 6600, 6650 and 7600 using <i>pneumatic</i> welding gun
Circuit Diagram		3HAC 17669-1	DressPack for IRB 6600, 6650 and 7600 using <i>servo</i> welding gun
Proc cable package assembly drawing		-	
Connection table		-	
Form shroud		3HAC 5323-1	Needed when reusing a dismantled weld power cable. The original form cannot be reused.
Hot air blower			For fitting of form shroud

Procedure

The procedure below details how to assemble the DressPack lower arm.

CAUTION!

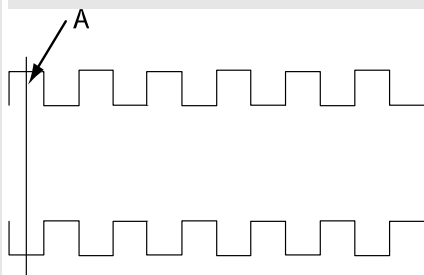

The cable packs are sensitive to mechanical damage! They must be handled with care, especially the connectors, in order to avoid damaging them!

Step	Action	Info/Illustration
1.	Make sure the correct parts are used.	All part numbers are specified in chapter Spare Parts .
2.	Fit the lower cable/hose retainer.	Detailed in section Fitting of cable/hose retainer on page 109. Only used in MH applications.
3.	Align the cable/hose package making sure each cable/hose is parallel to each other.	If required, rotate each individual hose in the retainer to make use of the natural bend of the hose. Make sure the hose bends coincide with the required bend of the complete package once fitted to the manipulator. If required, use adhesive masking tape to keep the cables hoses together during the assembly. NOTE! All tape must be removed after assembly.
4.	Apply a small amount of <i>cable grease</i> to the cables/hoses using a brush. All surfaces (except 100 mm close to the cable/hose retainer), of <i>each</i> cable or hose should be covered with grease.	Specified in section Required equipment on page 130. Make sure <i>no grease is applied</i> closer to a hose and cable retainer than 100 mm!
5.	Inspect the protective hose to make sure its ends have been cut correctly.	 xx0300000061 A: Cut the protective hose on top of a ridge
6.	Depending on the number of cables/hoses inside the protective hose, there are a few different methods of inserting them.	Detailed in sections Few hoses on page 111, Medium number of hoses on page 112 or Large number of hoses on page 112.
7.	Carefully check that the cable/hose package is not twisted in the front end.	
8.	Fit the front cable/hose retainer.	Detailed in section Fitting of cable/hose retainer on page 109.
9.	Push any <i>signal cabling</i> 50 mm into the front retainer.	This is done to remove/relieve the cables from tension.

4 Repairs

4.3.2. Assembly of DressPack lower arm

Step	Action	Info/Illustration
10	Remove the protective plastic from the connector pins and water nipples.	
11.	Assemble any connectors in the cable ends.	This varies depending on the application. Fit the connector pins as in the Circuit Diagram and Connection table, specified in section <i>Required equipment</i> on page 130.
12	Connect the complete cable/hose package connectors and nipples.	This varies depending on the application.
13	To make sure each pin is fitted in the correct position, we strongly recommend that the resistance of each wire is measured from end to end.	Check the wires as in the Circuit Diagram and Connection table, specified in section <i>Required equipment</i> on page 130.

Fitting of cable/hose retainer

This section details how to fit the cable/hose retainers.

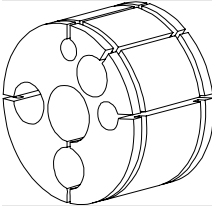
Step	Action	Info/Illustration
1.	Study the assembly drawing. Especially check the recommended lengths and mounting positions of the <i>hose and cable retainer</i> .	The illustration shows a generic retainer. The number of cable/hose holes differ between applications.  xx0300000246
2.	Mark all <i>clamping positions</i> with adhesive masking tape.	Specified on the assembly drawing.
3.	Fit the rear hose and cable retainer as shown in the assembly drawing.	Under <i>no circumstances</i> may any form of lubrication be applied to the retainer! If this should happen by accident, the lubrication must be carefully removed. Use a dry rag to wipe it clean. Make sure it is turned the right way. If required, a pair of heavy pliers may be used to open the cable/hose holes. Empty holes in the cable/hose retainer should be filled with fillers.

Few hoses

This section details how to insert the cables and hoses into the protective hose in cases where there are only a few cables/hoses.

	Action	Info/Illustration
1.	Gather all connector pins and water nipples and gently wrap them in protective plastic.	
2.	Keeping the cable/hose package together, gently insert the package into the protective hose.	
3.	Remove the protective plastic from the connector pins and water nipples.	
4.	Proceed where you left off above!	

Medium number of hoses

This section details how to insert the cables and hoses into the protective hose in cases where there are *more* than a few cables/hoses.

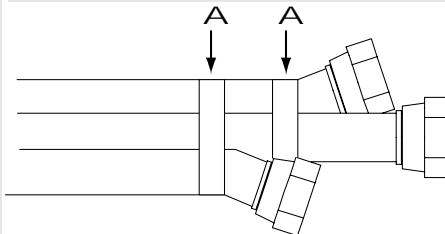
Step	Action	Info/Illustration
1.	Try to insert the cables/hoses as detailed in section Few hoses on page 111. If the complete package is too wide, proceed below:	
2.	Tape the cables/hoses together with the connectors/nipples staggered.	 <p>xx0300000253</p> <p>Parts:</p> <ul style="list-style-type: none"> A: Adhesive tape
3.	Gently insert the package into the protective hose.	
4.	Remove the protective plastic from the connector pins and water nipples.	
5.	Proceed where you left off above!	

Large number of hoses

This section details how to insert the cables and hoses into the protective hose in cases where there are a large number of cables/hoses.

4 Repairs

4.3.2. Assembly of DressPack lower arm

Step	Action	Info/Illustration
1.	Try to insert the cables/hoses as detailed in section <i>Medium number of hoses</i> on page 112. If the complete package is too wide, proceed below:	
2.	Cut the minimum amount of nipples from the package.	Cut as close to the nipple as possible. Since the original hose length was correct, this operation may only be performed a minimum number of times on each hose.
3.	Gather the remainder of the connector pins and water nipples and gently wrap them in protective plastic.	
4.	Gently insert the package into the protective hose.	
5.	Gently pull the cut hose through the protective hose.	If required, the protective hose may be squeezed gently to out-of-round to facilitate pulling the hose through.
6.	Refit the water nipple on the hose.	
7.	Proceed where you left off above!	

4.4 Water & Air unit

4.4.1. Replacement of Air supply circuit, std

Location of Air supply circuit

The Air supply circuit is located as shown in the figure below.

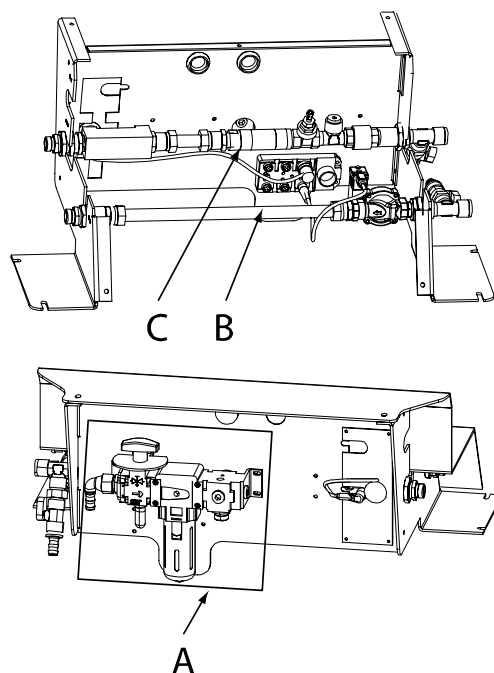

xx0300000125

A	Air supply circuit
B	Water-in circuit
C	Water-return circuit

Required equipment

Equipment, etc.	Spare part no.	Art. no.	Note
Air supply circuit	See the Spare parts section!		A number of versions are available.
Standard Toolkit, DressPack/Spotpack		3HAC 17290-7	The contents are defined in section Standard toolkit!
Other tools and procedures may be required. See references to these procedures in the step-by-step instructions below.			These procedures include references to the tools required.

4 Repairs

4.4.1. Replacement of Air supply circuit, std

Equipment, etc.	Spare part no.	Art. no.	Note
Circuit Diagram		3HAC 17669-2	DressPack for IRB 6600, 6650 and 7600 using <i>pneumatic</i> welding gun
Circuit Diagram		3HAC 17669-1	DressPack for IRB 6600, 6650 and 7600 using <i>servo</i> welding gun

Removal

The procedure below details how to remove the air supply circuit. It does not deal with details specific to each version, such as article numbers, connector types, etc. Such details are specified in the Spare Parts section.



WARNING!

Please observe the following before commencing any repair work on the manipulator:

- Motors and gears are HOT after running the robot! Touching the motors and gears may result in burns!
- Turn off all electric power, hydraulic and pneumatic pressure supplies to the robot!
- Take any necessary measures to ensure that the manipulator does not collapse as parts are removed, e.g. secure the lower arm with fixtures if removing motor, axis 2.

Step	Action	Info/Illustration
1.	Turn off the hand operated air valve on the air supply circuit.	The air hoses at the manipulator will be decompressed.
2.	Turn off the air supply to the water and air unit.	
3.	Remove the hose of the compressed air supply of the workshop.	
4.	Remove the Proc 1 hose from the air supply circuit.	
5.	Remove the Proc 4 hose from the air supply circuit.	This is only done if the option <i>proportional valve</i> is chosen.
6.	Disconnect the pressure switch connector on the the pressure switch.	This is only done if the option <i>pressure switch</i> is chosen.
7.	If the option proportional valve is chosen, perform the following: <ul style="list-style-type: none"> • Remove the cover of the water and air unit. • Disconnect the proportional valve connector on the split box according to the circuit diagram. • Cut the straps keeping the cable to the proportional valve. 	This is only done if the option <i>proportional valve</i> is chosen.
8.	Unscrew the four screws holding the air supply circuit.	

Refitting

The procedure below details how to refit the air supply circuit. It does not deal with details specific to each version, such as article numbers, connector types, etc. Such details are specified in the Spare Parts section.

**WARNING!**

Please observe the following before commencing any repair work on the manipulator:

- - Motors and gears are *HOT* after running the robot! Burns may result from touching the motors or gears!
- - Turn off all electric power, hydraulic and pneumatic pressure supplies to the robot!
- - Take any necessary measures to ensure that the manipulator does not collapse as parts are removed, e.g. to secure the lower arm with fixtures if removing motor, axis 2.

Step	Action	Info/Illustration
1.	Lead the signal cable of the proportional valve through the rear plate of the water and air unit.	This is done only if the option <i>proportional valve</i> is chosen.
2.	Fit the water and air unit with 4 screws.	
3.	If the option proportional valve is chosen do the following: <ul style="list-style-type: none"> • Connect the connector of the proportional valve on the connection of the split box according to the circuit diagram. • Bundle the cables behind the rear plate. • Check that no cables are squeezed against sharp edges! • Remount the cover of the water and air unit. 	This is done only if the option <i>proportional valve</i> is chosen.
4.	Connect the pressure switch connector on the pressure switch.	This is done only if the option <i>pressure switch</i> is chosen.
5.	Connect the Proc 4 hose from the manipulator to the air supply circuit.	This is done only if the option <i>proportional valve</i> is chosen.
6.	Connect the Proc 1 hose from the manipulator to the air supply circuit.	
7.	Connect the workshop compressed air supply hose, to <i>Air In</i> .	
8.	Turn on the air supply to the water and air unit.	
9.	Turn on the hand operated air valve on the air supply circuit.	The air hoses at the manipulator will be compressed.
10	Check for leakage.	Tighten if there is leakage!

4 Repairs

4.4.2. Replacement of Water-in circuit, std

4.4.2. Replacement of Water-in circuit, std

Location of Water-in circuit

The Water-in circuit is located as shown in the figure below.

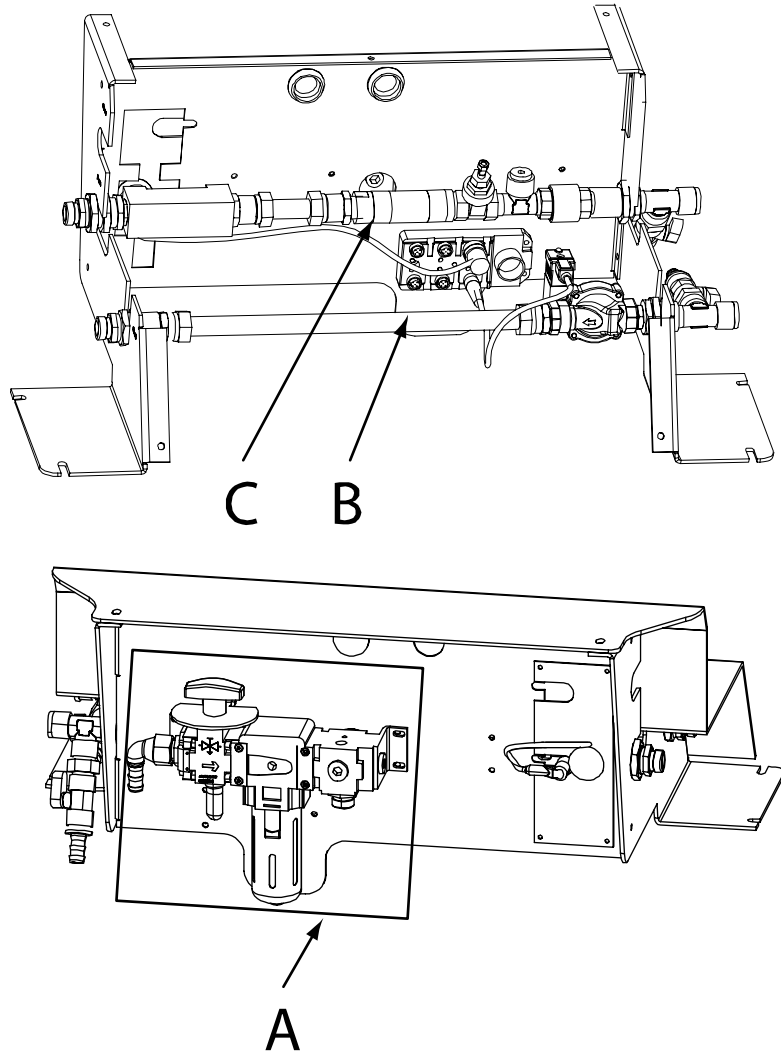

xx0300000125

A	Air supply circuit
B	Water-in circuit
C	Water-return circuit

Required equipment

Equipment, etc.	Spare part no.	Art. no.	Note
Water-in circuit	See the Spare parts section!		A number of versions are available.
Standard Toolkit, DressPack/SpotPack		3HAC 17290-7	The contents are defined in section Standard toolkit!
Other tools and procedures may be required. See references to these procedures in the step-by-step instructions below.			These procedures include references to the tools required.
Circuit Diagram		3HAC 17669-2	DressPack for IRB 6600, 6650 and 7600 using <i>pneumatic</i> welding gun
Circuit Diagram		3HAC 17669-1	DressPack for IRB 6600, 6650 and 7600 using <i>servo</i> welding gun

Removal

The procedure below details how to remove the Water-in circuit. It does not deal with details specific to each version, such as article numbers, connector types, etc. Such details are specified in the Spare Parts section.



WARNING!

Please observe the following before commencing any repair work on the manipulator:

- Motors and gears are HOT after running the robot! Touching the motors and gears may result in burns!
- Turn off all electric power, hydraulic and pneumatic pressure supplies to the robot!
- Take any necessary measures to ensure that the manipulator does not collapse as parts are removed, e.g. secure the lower arm with fixtures if removing motor, axis 2.

Step	Action	Info/Illustration
1.	Dismount the cover of the water and air unit.	
2.	Turn off the hand operated water inlet valve of the water and air unit.	
3.	Turn off the hand operated water return valve of the water and air unit.	
4.	Remove the Proc 2 hose from the water and air unit.	
5.	Dismount the hand operated valve of the water inlet.	
6.	Remove the coil from the electrical water valve.	
7.	Loosen the locking nuts.	
8.	Lift the water-in-circuit from the water and air unit.	

4 Repairs

4.4.2. Replacement of Water-in circuit, std

Refitting

The procedure below details how to refit the Water-in circuit. It does not deal with details specific to each version, such as article numbers, connector types, etc. Such details are specified in the Spare Parts section.



WARNING!

Warning

Please observe the following before commencing any repair work on the manipulator:

- - Motors and gears are *HOT* after running the robot! Burns may result from touching the motors or gears!
- - Turn off all electric power, hydraulic and pneumatic pressure supplies to the robot!
- - Take any necessary measures to ensure that the manipulator does not collapse as parts are removed, e.g. to secure the lower arm with fixtures if removing motor, axis 2.

Step	Action	Info/Illustration
1.	Place the water-in-circuit in the water and air unit.	
2.	Secure the water-in-circuit on the side that carries one locking nut.	
3.	Adjust the locking nuts on the other side in a way that the water-in-circuit not is exposed to tractive or compressive forces.	
4.	Tighten the locking nuts.	
5.	Remount the coil on the electrical water valve.	
6.	Connect the Proc 2 hose to the water and air unit.	See <i>Tightening torque</i> on page 13 in section <i>Screw joints</i> .
7.	Connect the hand operated water inlet valve.	See <i>Tightening torque</i> on page 13 in section <i>Screw joints</i> .
8.	Dry residual water.	This makes it easier to detect leakage.
9.	Turn on the hand operated water inlet valve of the water and air unit.	
10.	Influence the electrical water valve.	
11.	Wait a couple of minutes. Check for leakage!	
12.	In case of leakage, readjust!	
13.	Turn on the hand operated water return valve of the water and air unit.	
14.	Remount the cover of the water and air unit.	

4.4.3. Replacement of Water-return circuit, std

Location of Water-return circuit

The Water-return circuit is located as shown in the figure below.

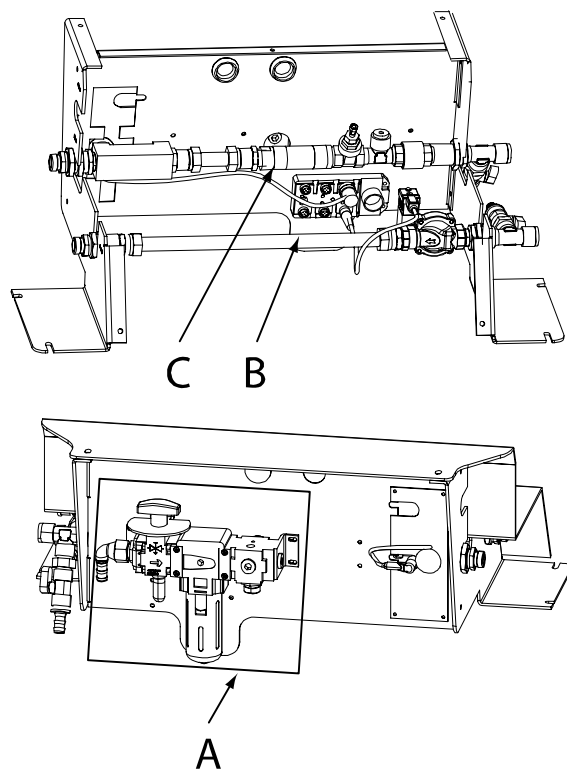

xx0300000125

A	Air supply circuit
B	Water-in circuit
C	Water-return circuit

Required equipment

Equipment, etc.	Spare part no.	Art. no.	Note
Water-return circuit	See the Spare parts section!		A number of versions are available.
Standard Toolkit, DressPack/SpotPack		3HAC 17290-7	The contents are defined in section Standard toolkit!
Other tools and procedures may be required. See references to these procedures in the step-by-step instructions below.			These procedures include references to the tools required.

4 Repairs

4.4.3. Replacement of Water-return circuit, std

Equipment, etc.	Spare part no.	Art. no.	Note
Circuit Diagram		3HAC 17669-2	DressPack for IRB 6600, 6650 and 7600 using <i>pneumatic</i> welding gun
Circuit Diagram		3HAC 17669-1	DressPack for IRB 6600, 6650 and 7600 using <i>servo</i> welding gun

Removal

The procedure below details how to remove the Water-return circuit. It does not deal with details specific to each version, such as article numbers, connector types, etc. Such details are specified in the Spare Parts section.



WARNING!

Please observe the following before commencing any repair work on the manipulator:

- Motors and gears are HOT after running the robot! Touching the motors and gears may result in burns!
- Turn off all electric power, hydraulic and pneumatic pressure supplies to the robot!
- Take any necessary measures to ensure that the manipulator does not collapse as parts are removed, e.g. secure the lower arm with fixtures if removing motor, axis 2.

Step	Action	Info/Illustration
1.	Dismount the cover of the water and air unit.	
2.	Turn off the hand-operated water inlet valve of the water and air unit.	
3.	Turn off the hand-operated water return valve of the water and air unit.	
4.	Remove the Proc 3 hose from the water and air unit.	
5.	Remove the Proc 4 hose from the water and air unit.	This is done only if option "Second water return" has been chosen.
6.	Mark the position of the straps before cutting them. Use marking tape, for example!	This is done in order to get the correct position of the hoses when remounting.
7.	Cut the straps.	
8.	Dismount the hand-operated water return valve.	
9.	Remove the contact of the flow indicator from the split box.	If option "Second water return" has been chosen, remove contacts from both flow indicators.
10.	Unscrew the locking nuts.	
11.	Lift the water-return-circuit from the water and air unit.	

Refitting

The procedure below details how to refit the Water-return circuit. It does not deal with details specific to each version, such as article numbers, connector types, etc. Such details are specified in the Spare Parts section.



WARNING!

Warning!

Please observe the following before commencing any repair work on the manipulator:

- - Motors and gears are *HOT* after running the robot! Burns may result from touching the motors or gears!
- - Turn off all electric power, hydraulic and pneumatic pressure supplies to the robot!
- - Take any necessary measures to ensure that the manipulator does not collapse as parts are removed, e.g. to secure the lower arm with fixtures if removing motor, axis 2.

Step	Action	Info/Illustration
1.	Place the water-return-circuit in the water and air unit.	There are different versions of the water-return-circuit depending on if option "Second water return" or "Digital flow switch" has been chosen.
2.	Secure the water-return-circuit on the side that carries one locking nut.	
3.	Adjust the locking nuts on the other side in a way that the water-return-circuit not is exposed to tractive or compressive forces.	
4.	Tighten the locking nuts.	
5.	Connect the contact of the flow indicator on the split box.	Connect both contacts if option "Second water return" has been chosen. See circuit diagram in order to get connections correctly connected.
6.	Bundle the cables behind the rear plate.	
7.	Check that no cables are squeezed against sharp edges.	
8.	Connect the Proc 3 hose to the water and air unit.	See <i>Tightening torque</i> on page 13 in section <i>Screw joints</i> .
9.	Connect the Proc 4 hose from the water and air unit.	This is done only if option "Second water return" has been chosen. See <i>Tightening torque</i> on page 13 in section <i>Screw joints</i> .
10.	Connect the hand operated water return valve.	See <i>Tightening torque</i> on page 13 in section <i>Screw joints</i> .
11.	Dry residual water.	This makes it easier to detect leakage.
12.	Turn on the hand operated water inlet valve of the water and air unit.	
13.	Activate the electrical water valve.	
14.	Wait a couple of minutes. Check for leakage!	
15.	In case of leakage, readjust!	

4 Repairs

4.4.3. Replacement of Water-return circuit, std

Step	Action	Info/Illustration
16	Turn on the hand operated water return valve of the water and air unit.	
17	Mount straps according to markings made earlier when removing the water-return-circuit.	This is described in this section Removal on page 142.
18	Remount the cover of the water and air unit.	
19	Reset the flow switch if necessary.	

4.4.4. Replacement of air filter element

Replacement of air filter element.

The procedure below details how to replace the filter element in the pressure regulator.

Step	Action	Info/Illustration
1.	Turn off the hand operated air valve and let the air pressure leak out.	
2.	Remove the black protective cover.	This is done by pushing down the spring latch and turning the protective cover 1/8 rev. to the left.
3.	Pull the protective cover downwards.	
4.	Remove the filter receptacle.	This is done by turning it 1/8 rev. to the left and then by pulling it downwards.
5.	Unscrew the filter bowl and pull it down.	
6.	Replace the old filter. Note! Grasp the new filter element only at the lower end!	Save the spring. It will be reused on the new filter element. OEM art. no of filter element: 97801732
7.	Refit the parts in the reverse order.	Reuse the spring! The spring is necessary to ensure correct function of the filter.
8.	Recommission the overpressure system.	

4 Repairs

4.5.1. Replacement of power unit, SpotPack

4.5 Power unit

4.5.1. Replacement of power unit, SpotPack

Location

The power unit is located as shown in the figure below.

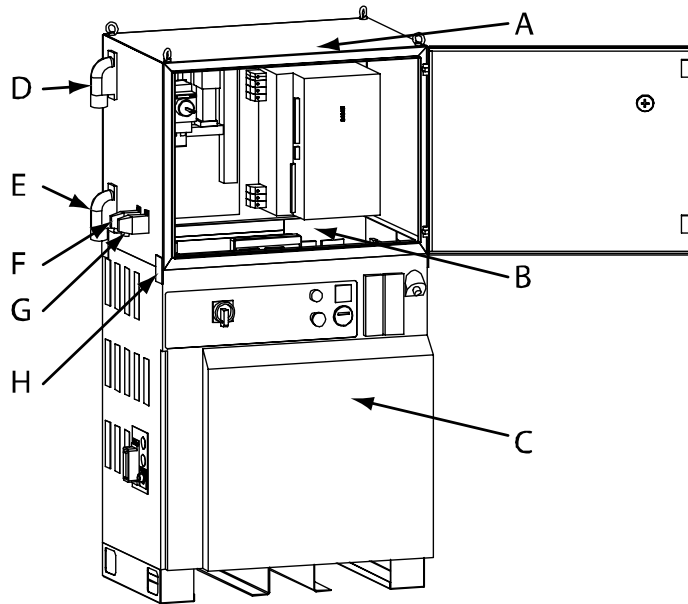

xx0300000147

A	Power unit
B	Area for accessing signal connections between power unit and controller
C	S4Cplus
D	Cable gland, shop power supply
E	Cable gland, power supply to manipulator
F	Connection, split box cable, XS103
G	Connection, stationary/pedestal gun, XS104
H	Enclosure bracket (4 pcs) with attachment screws (16 pcs in total)

Required equipment

Equipment, etc.	Spare part no.	Art. no.	Note
Standard toolkit		3HAC 17290-7	The contents are defined in section Standard toolkit!
Other tools and procedures may be required. See references to these procedures in the step-by-step instructions below.			These procedures include references to the tools required.

Equipment, etc.	Spare part no.	Art. no.	Note
Circuit Diagram		3HAC 17669-1	
Circuit Diagram		3HAC 17669-2	

**DANGER!**

Make sure the other end of the cable is disconnected from the line voltage before connecting to the mains power supply.

Removal

The procedure below details how to remove the power unit.

Step	Action	Note/Illustration
1.	Remove the rear cover plate on the manipulator by unscrewing its attachment screws.	
2.	Disconnect the earth cable.	
3.	Disconnect connectors R1.MP and R1.SMB.	
4.	Pull the cable and connectors up through the center of the frame.	
5.	Gently pull the cable harness out.	

**DANGER!**

Make sure the other end of the cable is disconnected from the line voltage before connecting to the mains power supply.

Refitting

The procedure below details how to refit the power unit.

Step	Action	Note/Illustration
1.	Remove the left hand side wrist cover by unscrewing its attachment screws.	
2.	Disconnect all connectors at motor 5 and motor 6.	
3.	Remove the plastic cover on the rear of the upper arm, by removing the attachment screws.	

4 Repairs

4.5.2. Replacement of circuit breaker QB101

4.5.2. Replacement of circuit breaker QB101

Location

The location of the different parts of the power unit is shown in the figure below.

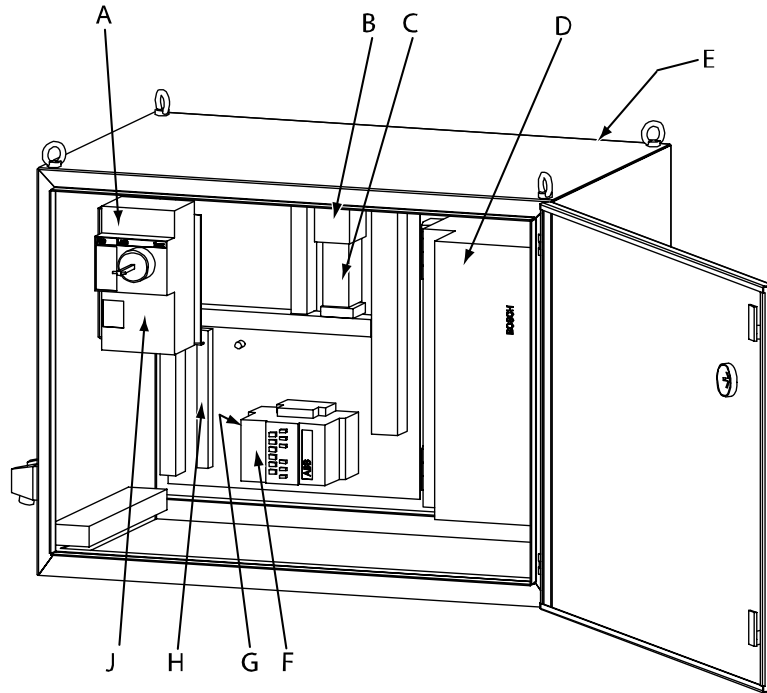

xx020000181

A	Circuit breaker
B	Fuse terminal
C	Mini contactors (Part of option: "Contactor for welding power")
D	Welding timer
E	Fan unit (Available as option). Placement at the back of the power unit
F	Welding contactor (Part of option: "Contactor for welding power")
G	Surge suppressor (Part of option: "Contactor for welding power"). Placement behind Welding contactor.
H	Earth bar
J	Earth fault protection (Available as option). Placement varies depending on version (AC or MFDC). This illustration shows placement of AC.

Removal

The procedure below details how to remove circuit breaker.

Step	Action	Note/Illustration
1.	Switch off circuit breaker on power unit.	
2.	Switch off circuit breaker on cabinet.	
3.	Switch off circuit breaker for incoming shop power supply.	

Step	Action	Note/Illustration
4.	Secure that the system is dead.	
5.	Open door of power unit.	
6.	Remove wires for incoming shop power supply.	
7.	Remove wires for outgoing shop power supply.	
8.	Dismount screws holding circuit breaker.	
9.	Lift out circuit breaker.	

Refitting

The procedure below details how to refit circuit breaker.

Step	Action	Info/Illustration
1.	Check that incoming shop power supply is dead.	
2.	Secure that power system is dead.	
3.	Confirm that new circuit breaker is the same as the one being replaced.	
4.	Fit circuit breaker using enclosed Philips screws.	For fitting instructions, see enclosed information delivered with circuit breaker.
5.	Fit wire for outgoing shop power supply.	See circuit diagram! Tightening torque 7 Nm.
6.	Fit wire for incoming shop power supply.	See circuit diagram! Tightening torque 7 Nm.
7.	Check that no strands are protruding from wires.	
8.	Check setting of breaking level (110A).	If needed, adjust level!
9.	Turn on circuit breaker for incoming shop power supply.	Exercise greatest caution when performing the following, since this is done with door of power unit open!
10.	Move circuit breaker to ON by using suitable tool on axis of circuit breaker.	
11.	Push testknob and check if circuit breaker is disconnected.	
12.	Move circuit breaker to OFF .	
13.	Close door .	
14.	Restart the system.	

4 Repairs

4.5.3. Replacement of earth fault protection

4.5.3. Replacement of earth fault protection

Location

The location of the different parts of the power unit, is shown in the figure below.

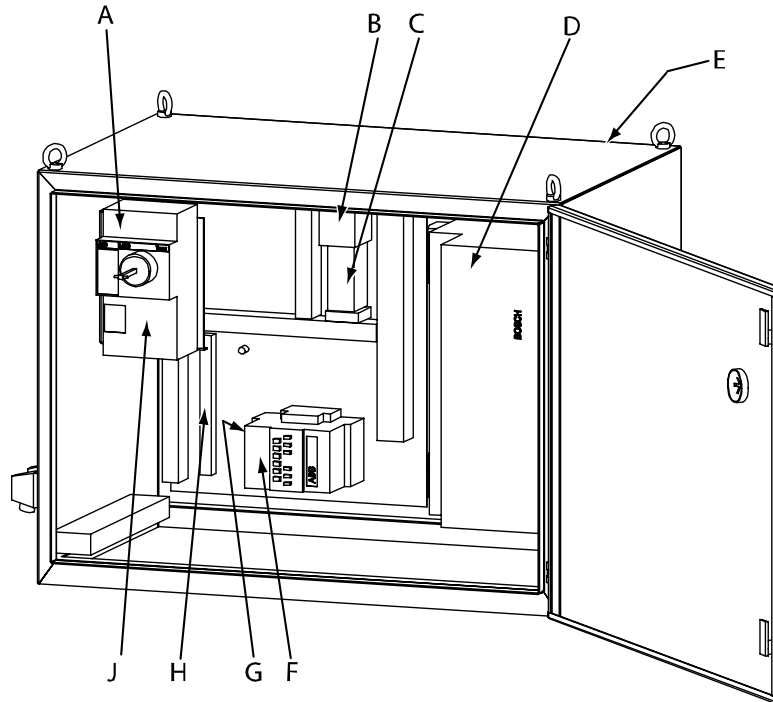

xx0300000181

A	Circuit breaker
B	Fuse terminal
C	Mini contactors (Part of option: "Contactor for welding power")
D	Welding timer
E	Fan unit (Available as option). Placement at the back of the power unit.
F	Welding contactor (Part of option: "Contactor for welding power")
G	Surge suppressor (Part of option: "Contactor for welding power"). Placement behind Welding contactor.
H	Earth bar
J	Earth fault protection (Available as option). Placement varies depending on version (AC or MFDC). This illustration shows placement of AC.

Preparations

The procedure below details what must be done before removal of the earth fault protection.

Step	Action	Info/Illustration
1.	Switch off circuit breaker on power unit.	
2.	Switch off circuit breaker on cabinet.	
3.	Switch off circuit breaker for incoming shop power supply.	

4.5.3. Replacement of earth fault protection

Step	Action	Info/Illustration
4.	Secure that power supply is dead.	
5.	Open door of power unit.	
6.	Remove wires for incoming shop power supply.	Socket head cap screw (4 mm)
7.	Remove wires for outgoing shop power supply.	Socket head cap screw (4 mm)

Removal and refitting

See suppliers recommendation for mounting and dismounting of earth fault protection.

4 Repairs

4.5.4. Replacement of minicontactors K101, K103

4.5.4. Replacement of minicontactors K101, K103

Location

The location of the different parts of the power unit, is shown in the figure below.

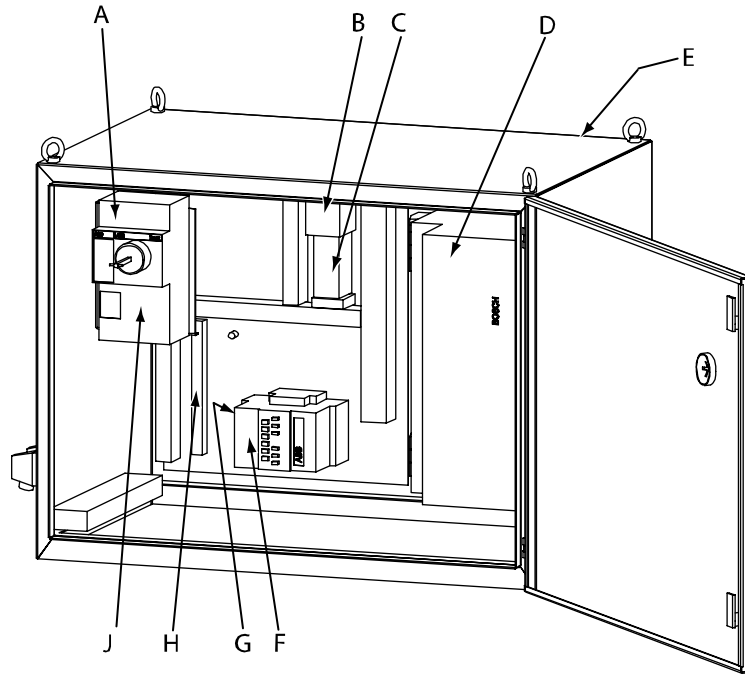

xx0300000181

A	Circuit breaker
B	Fuse terminal
C	Mini contactors (Part of option: "Contactor for welding power")
D	Welding timer
E	Fan unit (Available as option). Placement at the back of the power unit
F	Welding contactor (Part of option: "Contactor for welding power")
G	Surge suppressor (Part of option: "Contactor for welding power"). Placement behind Welding connector.
H	Earth bar
J	Earth fault protection (Available as option). Placement varies depending on version (AC or MFDC). This illustration shows placement of AC.

Removal of minicontactor K101

The procedure below details how to remove minicontactor K101.

Step	Action	Info/Illustration
1.	Switch off circuit breaker on power unit.	
2.	Switch off circuit breaker on cabinet.	
3.	Switch off circuit breaker for incoming shop power supply.	
4.	Secure that power supply is dead!	

4.5.4. Replacement of minicontactors K101, K103

Step	Action	Info/Illustration
5.	Open door of power unit!	
6.	Disconnect wires.	See circuit diagram!
7.	Dismount contactor.	

Refitting of minicontactor K101

The procedure below details how to refit minicontactor K101.

Step	Action	Info/Illustration
1.	Check that incoming shop power supply is dead.	
2.	Secure that power system is dead!	
3.	Confirm that new minicontactor is the same as the one being replaced.	
4.	Fit minicontactor with enclosed screws.	
5.	Reconnect wires.	See circuit diagram!

Removal of minicontactor K103

The procedure below details how to remove minicontactor K103.

Step	Action	Info/Illustration
1.	Switch off circuit breaker on power unit!	
2.	Switch off circuit breaker on cabinet.	
3.	Switch off circuit breaker for incoming shop power supply.	
4.	Secure that power system is dead!	
5.	Open door of power unit	
6.	Disconnect wires.	See circuit diagram!
7.	Dismount minicontactor.	

Refitting of minicontactor K103

The procedure below details how to refit minicontactor K103.

Step	Action	Info/Illustration
1.	Check that incoming shop power supply is dead!	
2.	Secure that power system is dead!	
3.	Confirm that new minicontactor is the same as the one being replaced.	
4.	Fit minicontactor with enclosed screws.	
5.	Reconnect wires.	See circuit diagram!

4 Repairs

4.5.5. Replacement of contactor QC101

4.5.5. Replacement of contactor QC101

Location

The location of the different parts of the power unit is shown in the figure below.

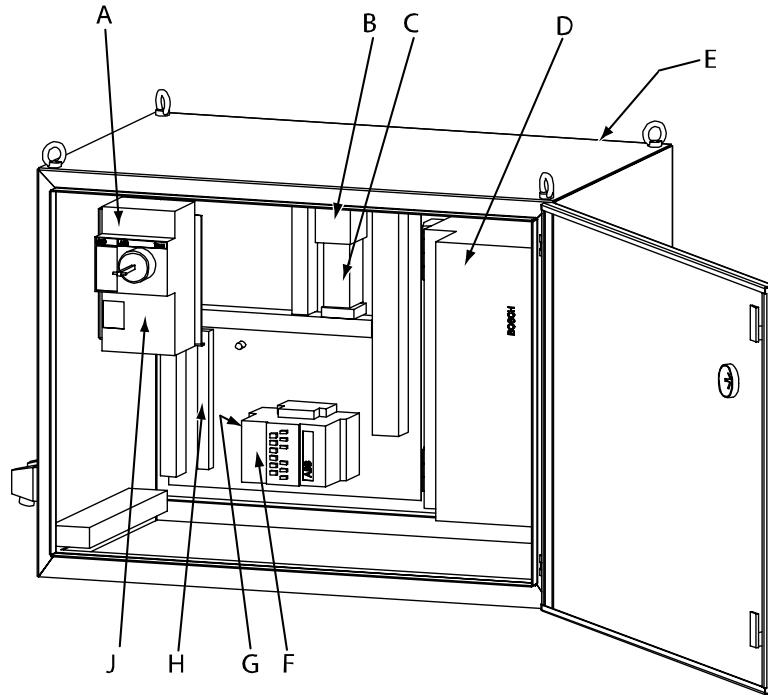

xx0300000181

A	Circuit breaker
B	Fuse terminal
C	Mini contactors (Part of option: "Contactor for welding power")
D	Welding timer
E	Fan unit (Available as option). Placement at the back of the power unit
F	Welding contactor (Part of option: "Contactor for welding power")
G	Surge suppressor (Part of option: "Contactor for welding power"). Placement behind Welding power.
H	Earth bar
J	Earth fault protection (Available as option). Placement varies depending on version (AC or MFDC). This illustration shows placement of AC.

Removal

The procedure below details how to remove contactor QC101.

Step	Action	Info/Illustration
1.	Switch off circuit breaker on power unit.	
2.	Switch off circuit breaker on cabinet.	
3.	Switch off circuit breaker for incoming shop power supply.	

4.5.5. Replacement of contactor QC101

Step	Action	Info/Illustration
4.	Secure that power supply is dead.	
5.	Open door of power unit.	
6.	Disconnect wire for incoming shop power supply.	Socket head cap screw (4 mm)
7.	Disconnect wire for outgoing shop power supply.	Socket head cap screw (4 mm)
8.	Disconnect wires.	See circuit diagram!
9.	Dismount screws holding contactor.	
10.	Unfasten screws holding contactor.	
11.	Remove contactor.	
12.	Remove surge suppressor from contactor and move to new contactor.	If surge suppressor is not functioning, replace it.

Refitting

The procedure below details how to remove contactor QC101.

Step	Action	Info/Illustration
1.	Check that incoming shop power supply is dead!	
2.	Secure that power system is dead, before refitting work starts!	
3.	Confirm that new contactor is the same as the one being replaced.	
4.	Fit surge suppressor on new contactor, if not already done.	
5.	Fit contactor using enclosed screws.	For fitting instructions, see enclosed information delivered with contactor.
6.	Reconnect wires for relay.	See circuit diagram!
7.	Reconnect wires for position switch.	See circuit diagram!
8.	Fit wire for outgoing shop power supply.	See circuit diagram! Tightening torque 6 Nm
9.	Fit wire for incoming shop power supply.	See circuit diagram! Tightening torque 6 Nm
10.	Check that no strands are protruding from wires.	
11.	Turn on circuit breaker for incoming shop power supply.	
12.	Turn on circuit breaker on cabinet.	Exercise greatest caution when performing the following, since it is done with door of power unit open!
13.	Move circuit breaker to ON by using suitable tool on axis of circuit breaker.	
14.	Push testknob on circuit breaker and check if contactor is disconnected.	
15.	Move circuit breaker to OFF .	
16.	Close door of power unit.	
17.	Restart system.	

4 Repairs

4.5.6. Replacement of timer VE101

4.5.6. Replacement of timer VE101

Location

The location of the different parts of the power unit is shown in the figure below.

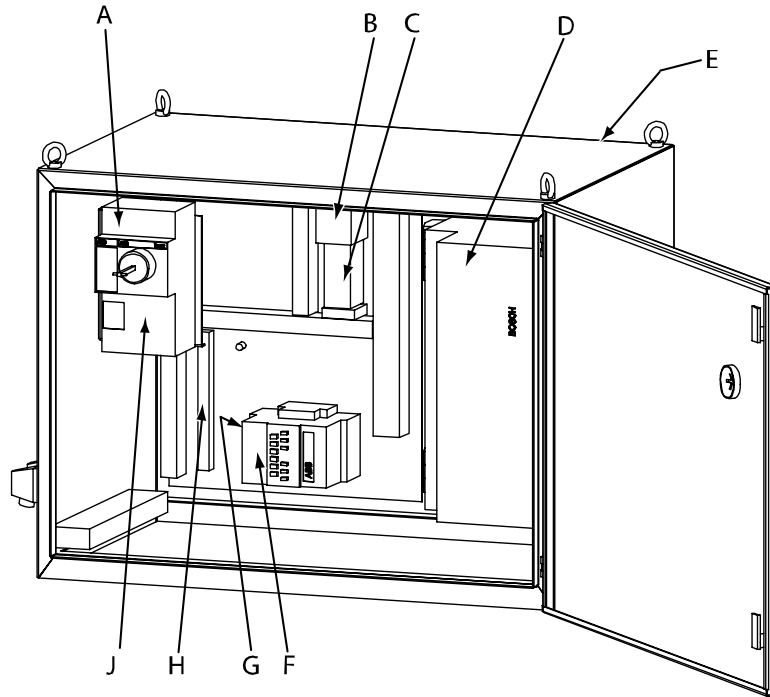

xx0300000181

A	Circuit breaker
B	Fuse terminal
C	Mini contactors (Part of option: "Contactor for welding power")
D	Welding timer
E	Fan unit (Available as option). Placement at the back of the power unit
F	Welding contactor (Part of option: "Contactor for welding power")
G	Surge suppressor (Part of option: "Contactor for welding power"). Placement behind Welding connector.
H	Earth bar
J	Earth fault protection (Available as option). Placement varies depending on version (AC or MFDC). This illustration shows placement of AC.

Removal

The procedure below details how to remove timer VE101.

Step	Action	Info/Illustration
1.	Switch off circuit breaker on power unit.	
2.	Switch off circuit breaker on cabinet.	
3.	Switch off circuit breaker for incoming shop power supply.	

Step	Action	Info/Illustration
4.	Secure that the system is dead.	
5.	Open door of power unit.	
6.	Disconnect wire for incoming shop power supply.	Socket head cap screw (5 mm)
7.	Disconnect wire for outgoing shop power supply.	Socket head cap screw (5 mm)
8.	Disconnect wires for timer.	
9.	Unfasten upper nuts.	Size 10 mm
10.	Unfasten lower nuts.	Size 10 mm
11.	Remove timer by unhooking it.	

Refitting

The procedure below details how to refit timer VE101.

Step	Action	Info/Illustration
1.	Check that incoming shop power supply is dead.	
2.	Secure that power system is dead.	
3.	Confirm that new timer is the same as the one being replaced.	
4.	Fit timer.	
5.	Connect wires for timer.	See circuit diagram!
6.	Connect wire for outgoing shop power supply.	See circuit diagram! Tightening torque 6 Nm
7.	Connect wire for incoming shop power supply.	See circuit diagram! Tightening torque 6 Nm
8.	Check that there are no strands protruding from wires.	
9.	Close door of power unit.	
10.	Restart system.	

4 Repairs

4.5.6. Replacement of timer VE101

5 Spare Parts

5.1. Introduction

General

This chapter contains more specific article information. It is to be regarded as a complement to the slightly generic procedure information found in the Installation, Maintenance and Repair chapters.

The robot itself, consisting of manipulator and controller cabinet, is detailed in its own technical documents.

5 Spare Parts

5.2. Abbreviations

5.2. Abbreviations

General

Several terms and wordings are used that are specific to the welding/material handling applications. These are explained in the list below.

Abbreviations and acronyms

Below are Abbreviations and acronyms explained:

Buscom

Cables specifically designed and dimensioned for bus communication as specified in the *Product Specification*.

CBUS

Any one of the process buses:

-
- Interbus
- Profibus
- DeviceNet

Usually part of the concept "CP/CBUS", i.e. "Customer power supply and customer bus communication".

CP

Customer Power as specified in the *Product Specification*.

Usually part of the concepts "CP/CS", i.e. "Customer power supply and customer signals" and "CP/CBUS", i.e. "Customer power supply and customer bus communication".

CS

Customer Signals as specified in the *Product Specification*.

Usually part of the concept "CP/CS", i.e. "Customer power supply and customer signals".

Paracom

Cables specifically designed and dimensioned for parallel communication as specified in the *Product Specification*.

MH

Material Handling applications. The various components included are specified in the *Product Specification*.

Corresponds to DressPack, type H.

SW

Spot Welding applications. The various components included are specified in the *Product Specification*.

Corresponds to DressPack/SpotPack, types S, HS, Se and HSe.

RG

Robot Gun, i.e. a welding gun that is fitted to the manipulator turning disk.

Corresponds to DressPack/SpotPack, types S and Se.

SG

Stationary/pedestal gun, i.e. a welding gun that is fitted on a pedestal rather than being carried by the manipulator.

Corresponds to DressPack/SpotPack, types HS and HSe.

7:th axis

Cable for 7:th axis from serial measurement card to robot base included.

5 Spare Parts

5.3.1. DressPack, upper arm, std

5.3 Upper arm harness

5.3.1. DressPack, upper arm, std

Illustration

The illustration below shows the complete unit in question as well as its components. Any callouts refer to the table in section *Parts* on page 162.

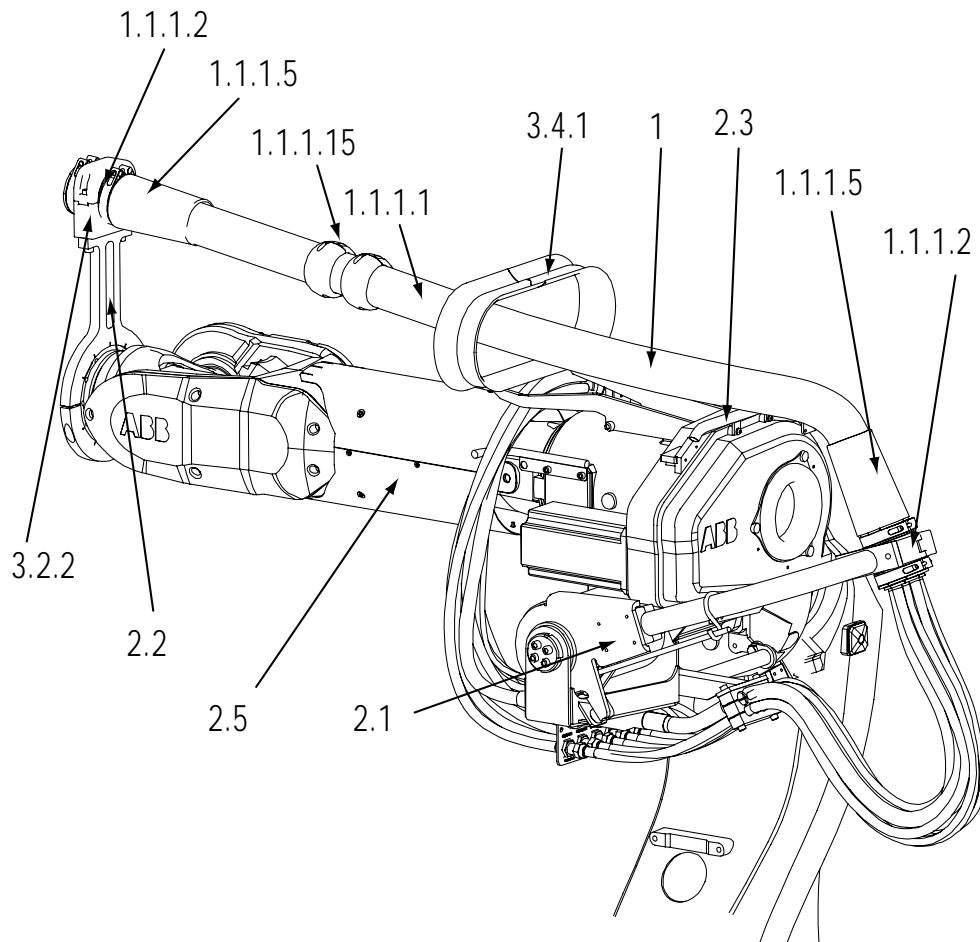

xx030000123

Parts

Item	Qty	Description	Art. no.	Rem.
1	1	Proc cable package 3-6 MH	3HAC 16647-1	IRBx600 2.55 & 6650 2.75 & 6650S 3.0 CP/CS, 1 hose
1	1	Proc cable package 3-6 MH	3HAC 16647-2	IRB6600 2.8 & 7600 2.8 CP/CS, 1 hose
1	1	Proc cable package 3-6 MH	3HAC 16647-3	IRB6650 3.2 & 6650S 3.5 CP/CS, 1 hose

Item	Qty	Description	Art. no.	Rem.
1	1	Proc cable package 3-6 MH	3HAC 16647-4	IRB 7600 3.5 CP/CS, 1 hose
1	1	Proc cable package 3-6 MH	3HAC 16647-5	IRB 7600 2.3 CP/CS, 1 hose
1	1	Proc cable package 3-6 MH	3HAC 16648-1	IRBx600 2.55 & 6650 2.75 & 6650S 3.0 CP/CBus, 1 hose
1	1	Proc cable package 3-6 MH	3HAC 16648-2	IRB6600 2.8 & 7600 2.8 CP/CBus, 1 hose
1	1	Proc cable package 3-6 MH	3HAC 16648-3	IRB6650 3.2 & 6650S 3.5 CP/CBus, 1 hose
1	1	Proc cable package 3-6 MH	3HAC 16648-4	IRB7600 3.5 CP/CBus, 1 hose
1	1	Procc cable package 3-6 MH	3HAC 16648-5	IRB7600 2.3 CP/CBus, 1 hose
1	1	Proc cable package 3-6 SW	3HAC 16643-1	IRBx600 2.55 & 6650 2.75 & 6650S 3.0 CP/CS, 3 hoses, 25 mm ²
1	1	Proc cable package 3-6 SW	3HAC 16643-2	IRB6600 2.8 & 7600 2.8 CP/CS, 3 hoses, 25 mm ²
1	1	Proc cable package 3-6 SW	3HAC 16643-3	IRB6650 3.2 & 6650S 3.5 CP/CS, 3 hoses, 25 mm ²
1	1	Proc cable package 3-6 SW	3HAC 16644-1	IRBx600 2.55 & 6650 2.75 & 6650S 3.0 CP/Cbus, 3 hoses, 25 mm ²
1	1	Proc cable package 3-6 SW	3HAC 16644-2	IRB6600 2.8 & 7600 2.8 CP/Cbus, 3 hoses, 25 mm ²
1	1	Proc cable package 3-6 SW	3HAC 16644-3	IRB6650 3.2 & 6650S 3.5 CP/Cbus, 3 hoses, 25 mm ²
1	1	Proc cable package 3-6 SW	3HAC 16645-1	IRBX600 2.55 & 6650 2.75 & 6650S 3.0 CP/CS, 4 hoses, 25 mm ²
1	1	Proc cable package 3-6 SW	3HAC 16645-2	IRB6600 2.8 & 7600 2.8 CP/CS, 4 hoses, 25 mm ²
1	1	Proc cable package 3-6 SW	3HAC 16645-3	IRB6650 3.2 & 6650S 3.5 CP/CS, 4 hoses, 25 mm ²
1	1	Proc cable package 3-6 SW	3HAC 16646-1	IRBX600 2.55 & 6650 2.75 & 6650S 3.0 CP/CBus, 4 hoses, 25 mm ²
1	1	Proc cable package 3-6 SW	3HAC 16646-2	IRB6600 2.8 & 7600 2.8 CP/CBus, 4 hoses, 25 mm ²
1	1	Proc cable package 3-6 SW	3HAC 16646-3	IRB6650 3.2 & 6650S 3.5 CP/CBus, 4 hoses, 25 mm ²

5 Spare Parts

5.3.1. DressPack, upper arm, std

Item	Qty	Description	Art. no.	Rem.
1.1.1 .1		Protective hose Ø80 mm or Protective hose Ø83 mm	3HAC5320-4 3HAC5320-2	Length: IRB7600 2.3 = 1850 mm IRBX600 2.55, 2.75, 3.0 S = 2000 mm IRB X600 2.8 = 2250 mm IRB6650 3.2 & 6650S 3.5 = 2450 mm IRB7600 3.5 = 2950 mm
1.1.1 .2	4	Slide sleeve	3HAC16208-1	
1.1.1 .5	2	Hose reinforcement	3HAC022194-001	
1.1.1 .15	2	Protection sleeve	3HAC16918-1	Used with Protective hose 3HAC5320-4
1.1.1 .15	2	Protection sleeve	3HAC021580-001	Used with Protective hose 3HAC5320-2
2.1	1	Retracting unit IRB6600	3HAC 15960-1	
2.1	1	Retracting unit IRB7600	3HAC 15966-1	
2.2	1	Proc.cable support axis 6	3HAC 16319-1	IRB66X0 all models & 6650S
2.2	1	Proc.cable support axis 6	3HAC 16314-1	IRB7600
2.3	1	Rear hose support	3HAC13981-10	IRB66X0, all models & 6650S
2.5	1	Arm protection	3HAC 16752-1	IRB6600 2.55 & 6650 2.75 & 6650S 3.0
2.5	1	Arm protection	3HAC 16752-5	IRB6600 2.8
2.5	1	Arm protection	3HAC 16752-9	IRB6650 3.2 & 6650S 3.5
2.5	1	Arm protection	3HAC 15718-1	IRB7600 2.55
2.5	1	Arm protection	3HAC 15718-3	IRB7600 2.8
2.5	1	Arm protection	3HAC 15718-6	IRB7600 3.5
3.2.2	1	Ball joint housing	3HAC021601-001	
3.4.1	1	Hose support	3HAC14529-1	Does <i>not</i> include brackets!
3.4.1	1	Bracket for hose support	3HAC14529-2	IRB66X0, all models & 6650S
3.4.1	1	Bracket for hose support	3HAC14529-3	IRB66X0, all models & 6650S
3.4.1	1	Bracket for hose support	3HAC13981-23	IRB7600

5.3.2. Retracting unit, IRB 66x0 & 7600, std

Illustration

The illustration below shows the complete unit in question as well as its components. Any callouts refer to the table in section [Parts](#) on page 165.

The illustration shows retracting unit for IRB6x00. This principle illustration is also applicable to IRB7600, although there are some minor differences.

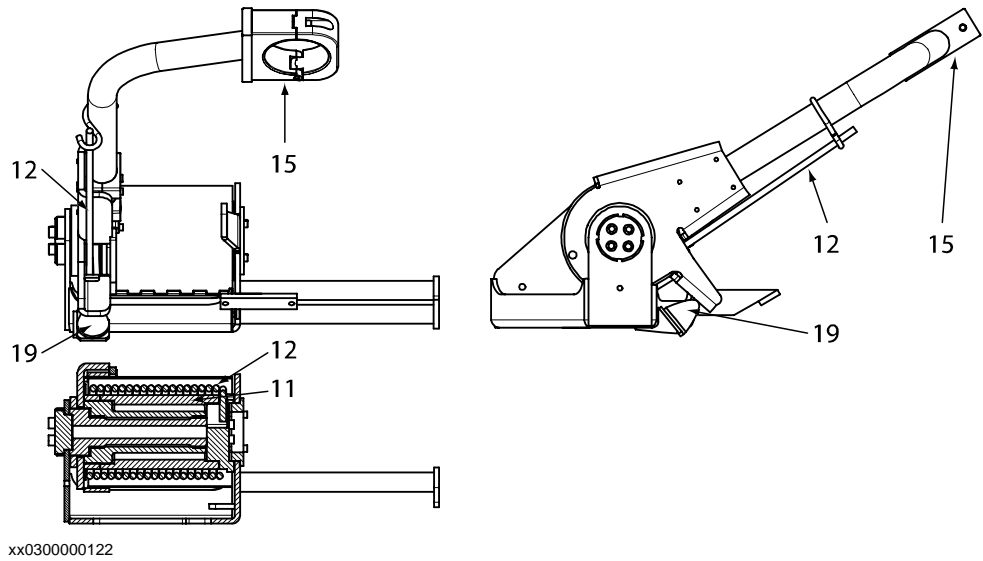

Parts

Item	Qty	Description	Art. no.	Rem.
1.11	1	Spring support	3HAC 15897-7	
1.12	1	Spring	3HAC 15897-2	
1.15	1	Ball joint housing	3HAC 021601-001	
1.19	1	Damper	3HAC 14230-18	

5 Spare Parts

5.4.1. DressPack, lower arm, std

5.4 Lower arm harness

5.4.1. DressPack, lower arm, std

Illustration

The illustration below shows the complete unit in question as well as its components. Any callouts refer to the table in section *Parts* on page 166.

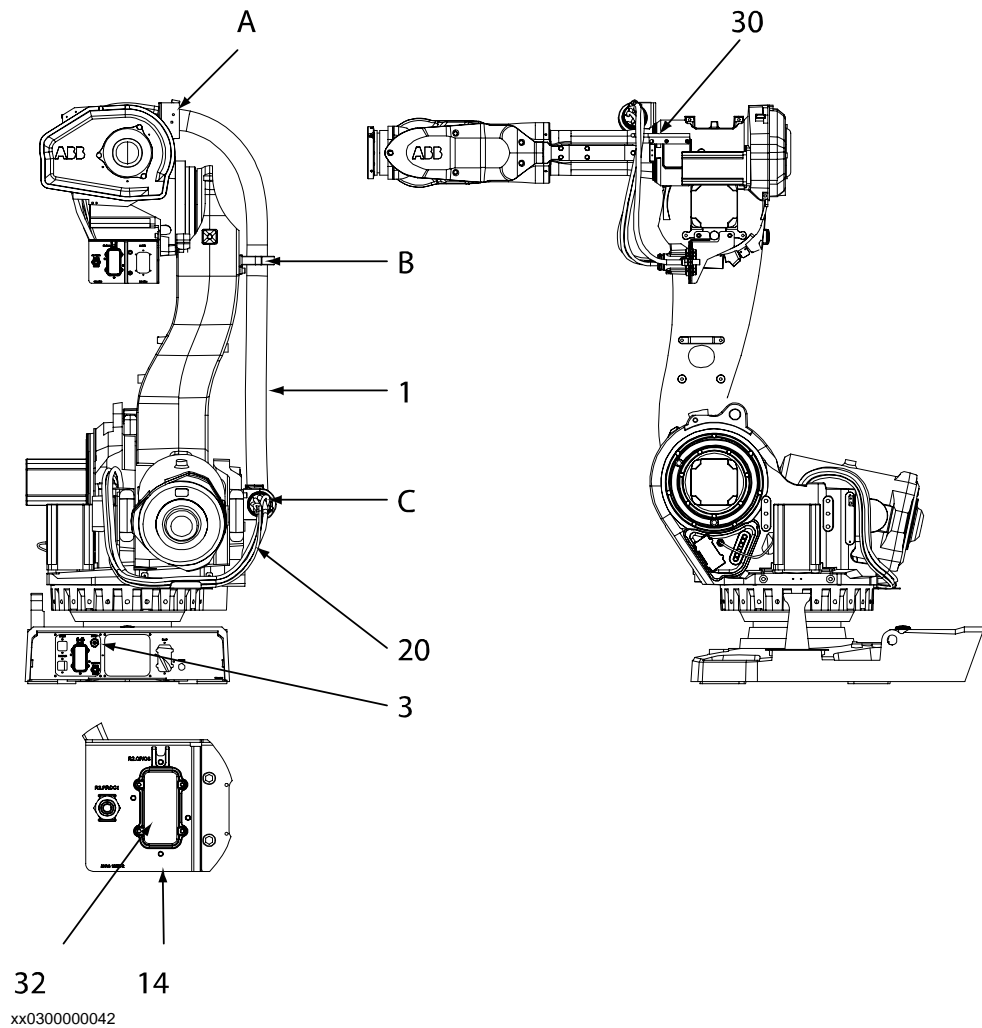

Parts

Item	Qty	Description	Art. no	Rem.
A, B and C		Cable attachments		The upper, mid and lower cable attachments are made up of common parts. These are specified in section <i>DressPack lower arm, cable clamp attachments</i> on page 169.
1	1	Process Cable Package	3HAC 16780-1	IRB 6600/7600, axes 1-3 CP/CS, 3 hoses, 35 mm ²

Item	Qty	Description	Art. no	Rem.
1	1	Process Cable Package	3HAC 16781-1	IRB 6650 & 6650S, axes 1-3 CP/CS, 3 hoses, 35 mm ²
1	1	Process Cable Package	3HAC 16782-1	IRB 6600/7600, axes 1-3 CP/CS, 3 hoses, 35 mm ² , SG
1	1	Process Cable Package	3HAC 16783-1	IRB 6650 & 6650S, axes 1-3 CP/CS, 3 hoses, 35 mm ² , SG
1	1	Process Cable Package	3HAC 16784-1	IRB 6600/7600, axes 1-3 CP/CBUS, 3 hoses 35 mm ²
1	1	Process Cable Package	3HAC 16785-1	IRB 6650 & 6650S, axes 1-3 CP/CBUS, 3 hoses, 35 mm ²
1	1	Process Cable Package	3HAC 16786-1	IRB 6600/7600, axes 1-3 CP/CS, 4 hoses, 35 mm ²
1	1	Process Cable Package	3HAC 16787-1	IRB 6650 & 6650S, axes 1-3 CP/CS, 4 hoses, 35 mm ²
1	1	Process Cable Package	3HAC 16788-1	IRB 6600/7600, axes 1-3 CP/CS, 4 hoses, 35 mm ² , SG
1	1	Process Cable Package	3HAC 16789-1	IRB 6650 & 6650S, axes 1-3 CP/CS, 4 hoses, 35 mm ² , SG
1	1	Process Cable Package	3HAC 16790-1	IRB 6600/7600, axes 1-3 CP/CBUS, 4 hoses, 35 mm ²
1	1	Process Cable Package	3HAC 16791-1	IRB 6650 & 6650S, axes 1-3 CP/CBUS, 4 hoses, 35 mm ²
1	1	Process Cable Package	3HAC 16792-1	IRB 6600/7600, axes 1-3 CP/CS, 1 hose
1	1	Process Cable Package	3HAC 16793-1	IRB 6650 & 6650S, axes 1-3 CP/CS, 1 hose
1	1	Process Cable Package	3HAC 16794-1	IRB 6600/7600, axes 1-3 CP/CS, 1 hose, SG
1	1	Process Cable Package	3HAC 16795-1	IRB 6650 & 6650S, axes 1-3 CP/CS, 1 hose, SG
1	1	Process Cable Package	3HAC 16796-1	IRB 6600/7600, axes 1-3 CP/CBUS, 1 hose
1	1	Process Cable Package	3HAC 16797-1	IRB 6650 & 6650S, axes 1-3 CP/CBUS, 1 hose
1	1	Process Cable Package	3HAC 020343-001	IRB6600 & 7600, axes 1-3 CP/CBUS, 3 hoses, 35 mm ² 7th axis
1	1	Process Cable Package	3HAC 020344-001	IRB6650 & 6650S, axes 1-3 CP/CBUS, 3 hoses 35 mm ² 7th axis
1	1	Process Cable Package	3HAC 020345-001	IRB6600 & 7600, axes 1-3 CP/CBUS, 4 hoses 35 mm ² 7th axis
1	1	Process Cable Package	3HAC 020346-001	IRB6650 & 6650S, axes 1-3 CP/CBUS, 4 hoses 35 mm ² 7th axis

5 Spare Parts

5.4.1. DressPack, lower arm, std

Item	Qty	Description	Art. no	Rem.
1	1	Process Cable Package	3HAC 020273-001	IRB6600 & 7600, axes 1-3 CP/CBUS, 1 hose 7th axis
1	1	Process Cable Package	3HAC 020288-001	IRB6650 & 6650S, axes 1-3 C/CBUS, 1 hose 7th axis
3	1	Jumper connector	3HAC 15877-1	For IRB 66x0/7600
14	2	Adapter, complete	3HAC 11774-3	
17	1	Weldconnector bracket	3HAC 8534-2	SW versions only. The location is shown in the Installation, DressPack lower arm process cable package on page 32 chapter.
20	7	Strap, Velcro 25x450	3HAC 12625-1	The location is shown in Location of DressPack lower arm on page 27, section <i>DressPack lower arm</i> .
30	1	Cable guide	3HAC 13637-6	The location is shown in the Location of DressPack lower arm on page 27, section <i>DressPack lower arm</i> .
32	2	Protection cover	3HAC 13416-1	

5.5 DressPack lower arm, cable clamp attachment sets, std

5.5.1. DressPack lower arm, cable clamp attachments

Illustration

The illustration below shows the complete unit in question as well as its components. Any callouts refer to the table in section [Parts](#) on page 169.

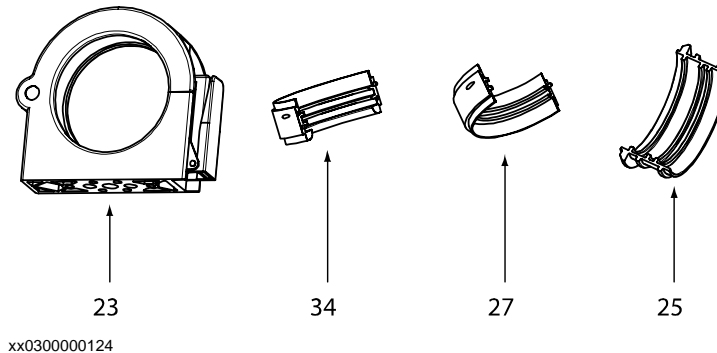

Parts

Item	Qty	Description	Art. no.	Rem.
23	See in tables below!	Gripping clamp	3HAC 14280-1	Part of the following attachment sets: 3HAC021526-001, 3HAC021526-002 and 3HAC021526-003
25	See in tables below!	Clamp Jaw	3HAC 14590-1	Part of the following attachment set: 3HAC021526-001
27	See in tables below!	Middle Jaw	3HAC 14290-1	Part of the following attachment set: 3HAC021526-002
34	See in tables below!	End Jaw	3HAC 14512-1	Part of the following attachment set: 3HAC021526-003

Robot models and cable clamp attachment sets

The table below shows what cable clamp attachment set is used on **IRB6600, 6650 and 7600**.

IRB6600, 6650 and 7600	Upper attachment	Middle attachment	Lower attachment
SW DressPack	3HAC021526-001 (1 pc)	3HAC021526-002 (1 pc)	3HAC021526-003 (1 pc)
MH DressPack	3HAC021526-001 (1 pc)	3HAC021526-002 (1 pc)	3HAC021526-001 (1 pc)

5 Spare Parts

5.5.1. DressPack lower arm, cable clamp attachments

The table below shows what cable clamp attachment set is used on **IRB6650S**.

IRB6650S	Upper attachment	Middle attachment	Lower attachment
SW DressPack	3HAC021526-001 (1 pc)	3HAC021526-002 (2 pcs)	3HAC021526-003 (1 pc)
MH DressPack	3HAC021526-001 (1 pc)	3HAC021526-002 (2 pcs)	3HAC021526-001 (1 pc)

NOTE! There are two middle cable clamp attachment sets used on the IRB6650S - Middle front and Middle back.

NOTE! The upper cable clamp attachment set is also used as lower attachment on MH robots, all models.

5.6 Floor harness

5.6.1. DressPack, floor, std

Illustration

The illustration below shows the complete unit in question as well as its components. Any callouts refer to the table in section [Parts](#) on page 171.

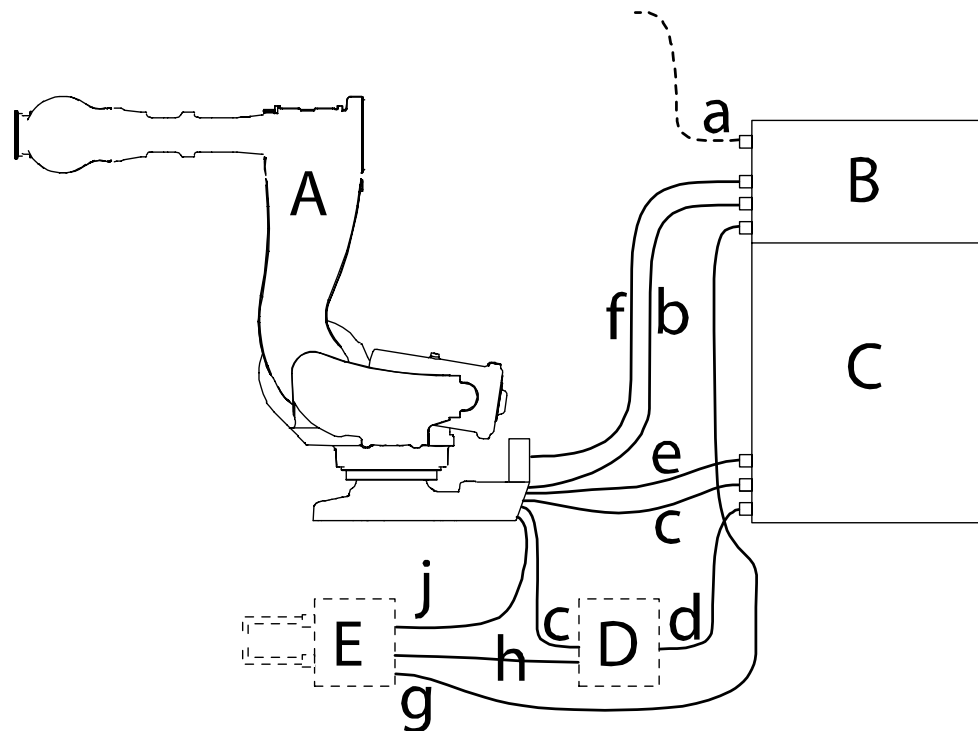

xx0300000170

Parts

Item	Description	Art. no.	Rem.
b	Floor weld cable	3HAC 16847-1	7 m 3 x 35 mm ² MC conn.
b	Floor weld cable	3HAC 16847-2	15 m 3 x 35 mm ² MC conn.
c	Harness CP/CS, axis 7	3HAC 14959-1	15 m Not used with e! Used with d.
c	Harness CP/CS, axis 7	3HAC 14959-4	7 m Not used with e! Used with d.

5 Spare Parts

5.6.1. DressPack, floor, std

Item	Description	Art. no.	Rem.
c	Harness CP/CS, axis 7	3HAC 14959-5	30 m Not used with e! Used with d.
d	Cable harness DDU	3HAC 15910-1	5 m Used with c.
e	Harness CP/CS PROFIB	3HAC 17200-1	15 m For ProfiBus communication. Not used with c!
e	Harness CP/CS PROFIB	3HAC 17200-4	7 m For ProfiBus communication. Not used with c!
e	Harness CP/CS PROFIB	3HAC 17200-5	30 m For ProfiBus communication. Not used with c!
e	Harness CP/CS CAN	3HAC 14890-1	15 m For CANBus communication. Not used with c!
e	Harness CP/CS CAN	3HAC 14890-4	7 m For CANBus communication. Not used with c!
e	Harness CP/CS CAN	3HAC 14890-6	30 m For CANBus communication. Not used with c!
e	Harness CP/CS IBS	3HAC 15644-1	15 m For InterBus communication. Not used with c!
e	Harness CP/CS IBS	3HAC 15644-4	7 m For InterBus communication. Not used with c!
e	Harness CP/CS IBS	3HAC 15644-5	30 m For InterBus communication. Not used with c!
e	Harness CP/CS	3HAC 17147-1	7 m No databus communication. Not used with c!
e	Harness CP/CS	3HAC 17147-2	15 m No databus communication. Not used with c!
e	Harness CP/CS	3HAC 17147-3	30 m No databus communication. Not used with c!
f	Cable to split box, 7 m	3HAC 16844-1	7 m Used with water and air unit.
f	Cable to split box, 15 m	3HAC 16844-2	15 m Used with water and air unit.
f	Cable to split box, 30 m	3HAC 16844-3	30 m Used with water and air unit.

Item	Description	Art. no.	Rem.
g	Process cable to stat gun, 7 m	3HAC 16873-1	7 m
g	Process cable to stat gun, 15 m	3HAC 16873-2	15 m
g	Process cable to stat gun, 30 m	3HAC 16873-3	30 m
h	Harness servo gun, 7 m	3HAC 15386-4	7 m
h	Harness servo gun, 15 m	3HAC 15386-1	15 m
h	Harness servo gun, 30 m	3HAC 15386-5	30 m
j	SMB signal cable, 7 m	3HAC 16425-1	7 m

5 Spare Parts

5.6.2. Connection kits, std

5.6.2. Connection kits, std

Illustration

The illustration below shows the complete unit in question as well as its components. (Cables are not included in kits!) Any callouts refer to the table in section Parts.

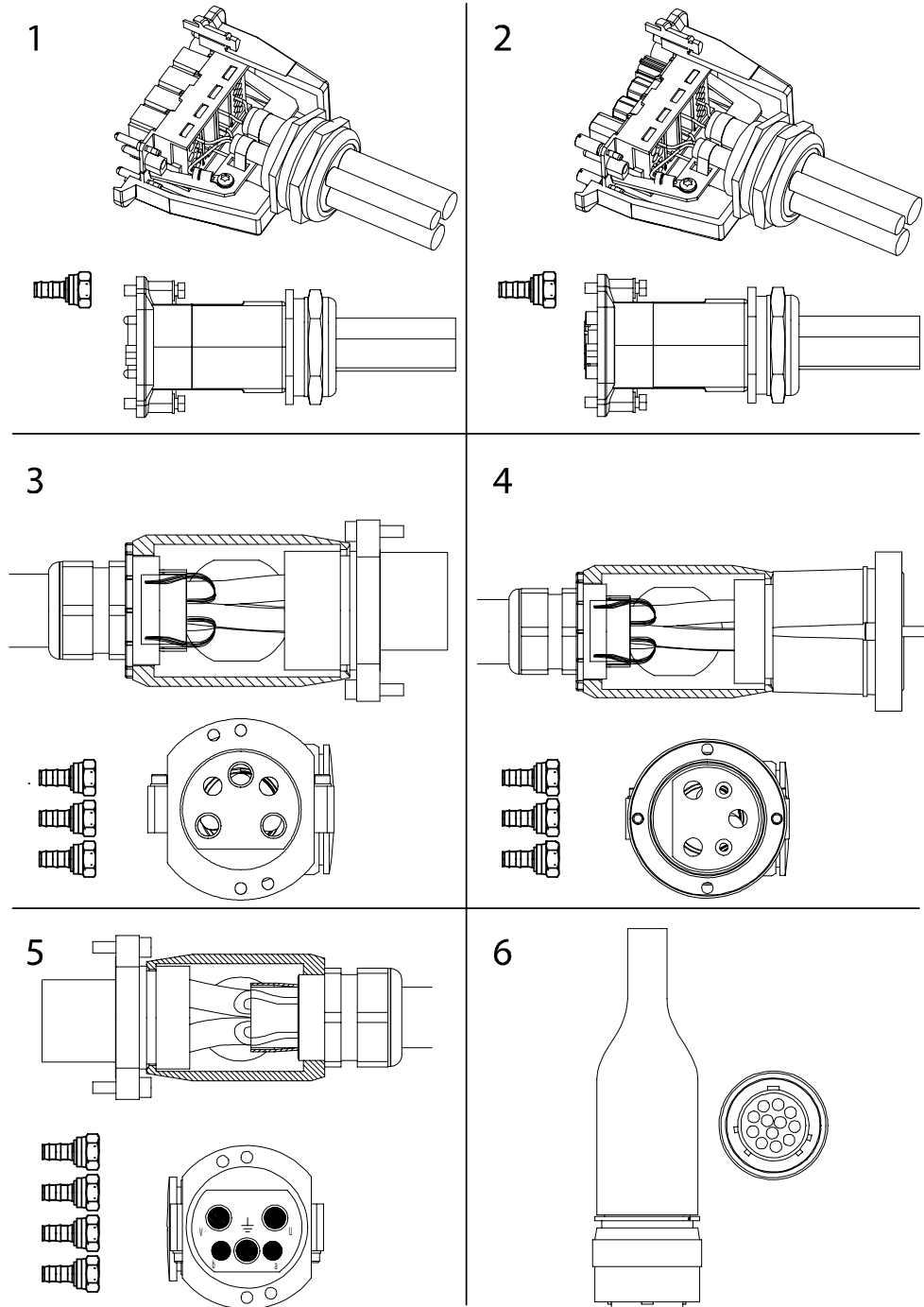

xx0300000208

Parts

Item	Qty	Description	Art. no.	Rem.
1	1	Connection Kit	3HAC 16642-1	IRB6X00/7600 CP/CS, Proc 1 axis 3 The kit includes all required hardware as well as an assembly instruction.
2	1	Connection Kit	3HAC 16667-1	IRB6X00/7600 CP/CS, Proc 1 on base The kit includes all required hardware as well as an assembly instruction.
3	1	Connection Kit	3HAC 17201-1	IRB6X00/7600 Weld, Proc 2-4 on base The kit includes all required hardware as well as an assembly instruction.
4	1	Connection Kit	3HAC 17202-1	IRB6X00/7600 Weld, Proc 2-4 axis 3 The kit includes all required hardware as well as an assembly instruction.
5	1	Connection Kit	3HAC 17203-1	IRB6X00/7600 Weld, Proc 1-4 axis 6 The kit includes all required hardware as well as an assembly instruction.
6	1	Connection Kit	3HAC 17204-1	IRB6X00/7600 7-axis on base The kit includes all required hardware as well as an assembly instruction.

5 Spare Parts

5.7.1. Water & Air unit, std

5.7 Water & Air unit, std

5.7.1. Water & Air unit, std

Illustration

The illustration below shows the complete unit in question as well as its components. Any callouts refer to the table in section *Parts* on page 176.

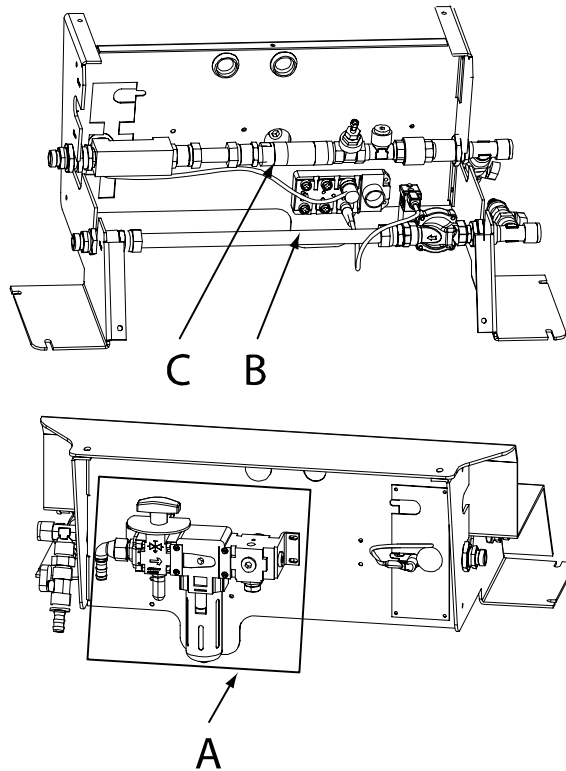

xx0300000125

A	Air supply circuit
B	Water-in circuit
C	Water-return circuit

Parts

Item	Description	Art. no.	Rem.
-	Water & Air unit	3HAC 16711-1	
-	Water & Air unit	3HAC 16711-2	Press switch and regulator
-	Water & Air unit	3HAC 16711-3	Two water returns
-	Water & Air unit	3HAC 16711-4	Press switch and regulator Two water returns
-	Water & Air unit	3HAC 16711-5	Proportional valve
-	Water & Air unit	3HAC 16711-6	Press switch and regulator Proportional valve

Item	Description	Art. no.	Rem.
-	Water & Air unit	3HAC 16711-7	Digital flow meter
-	Water & Air unit	3HAC 16711-8	Press switch and regulator Digital flow meter
-	Water & Air unit	3HAC 16711-9	Two water returns Digital flow meter
-	Water & Air unit	3HAC 16711-10	Press switch and regulator Two water returns Digital flow meter
-	Water & Air unit	3HAC 16711-11	Proportional valve Digital flow meter
-	Water & Air unit	3HAC 16711-12	Proportional valve Press switch and regulator Digital flow meter
-	Hose, water and air unit	3HAC 16845-1	For Proc1
-	Hose, water and air unit	3HAC 16845-2	For Proc2, Proc3 and Proc4 if used.
A, B and C	Air supply circuit Water-in circuit Water-return circuit	-	Specified in their sections respectively!

5 Spare Parts

5.7.2. Air supply circuits

5.7.2. Air supply circuits

Illustration

The illustration below shows the complete unit in question as well as its components. Any callouts refer to the table in section [Parts](#) on page 178.

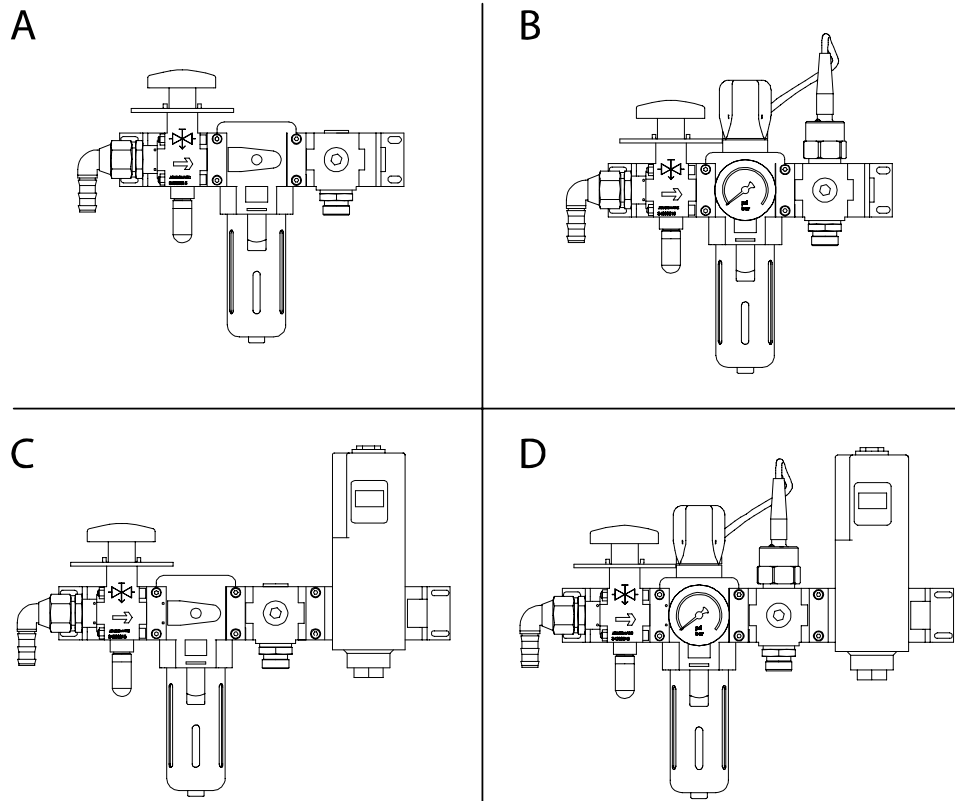

xx0300000210

Parts

Item	Description	Art.no.	Rem.
A	Air supply circuit	3HAC 17120-1	
B	Air supply circuit	3HAC 17121-1	Pressure switch and regulator
C	Air supply circuit	3HAC 17122-1	Proportional valve
D	Air supply circuit	3HAC 17123-1	Pressure switch and regulator Proportional valve

5.7.3. Water-in circuits, std

Illustration

The illustration below shows the complete unit in question as well as its components. Any callouts refer to the table in section *Parts* on page 179.

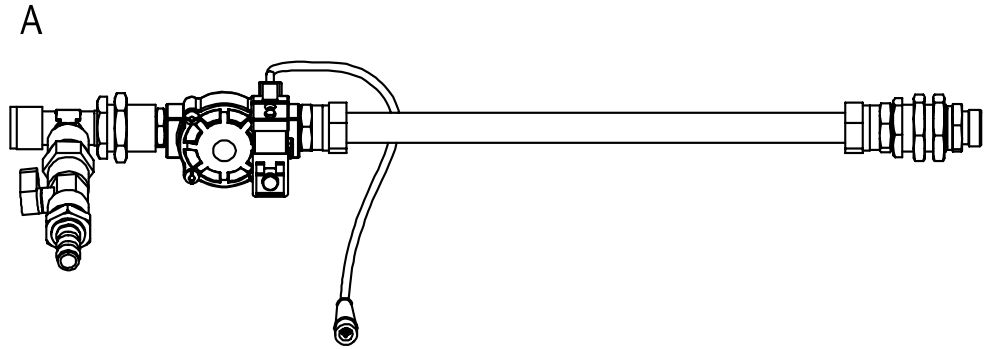

xx0300000211

Parts

Item	Description	Art.no.	Remark
A	Water-in circuit	3HAC 17124-1	

5 Spare Parts

5.7.4. Water-return circuits, std

5.7.4. Water-return circuits, std

Illustration

The illustration below shows the complete unit in question as well as its components. Any callouts refer to the table in section *Parts* on page 180.

A

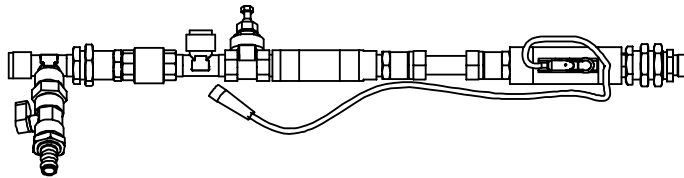

B

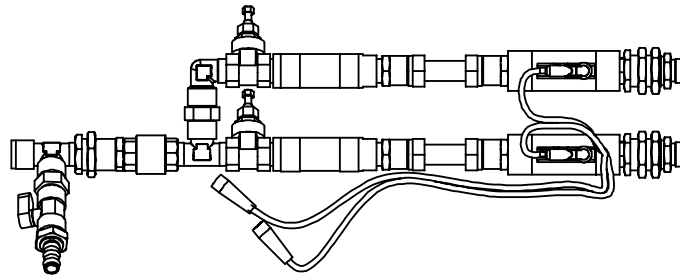

C

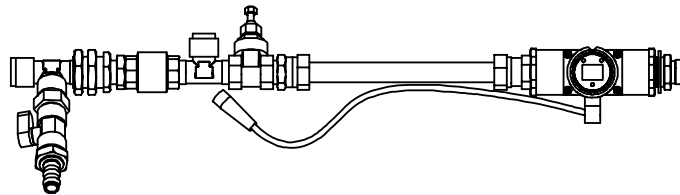

D

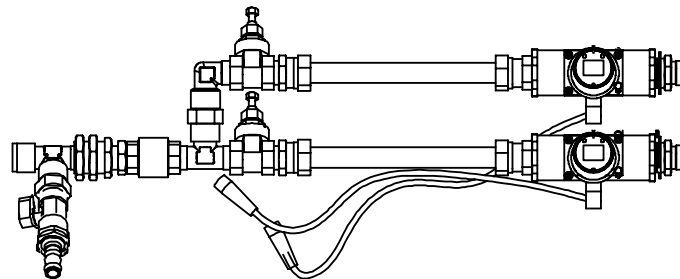

xx0300000212

Parts

Item	Qty	Description	Art.no.	Rem.
A	1	Water-return circuit	3HAC 17125-1	One water return
B	1	Water-return circuit	3HAC 17126-1	Two water returns
C	1	Water-return circuit	3HAC 17127-1	One water return Digital flow switch
D	1	Water-return circuit	3HAC 17128-1	Two water returns Digital flow switch

5.8 Power unit

5.8.1. Power unit, std

Illustration

The illustration below shows the complete unit in question as well as its components. Any callouts refer to the table in section [Parts](#) on page 181.

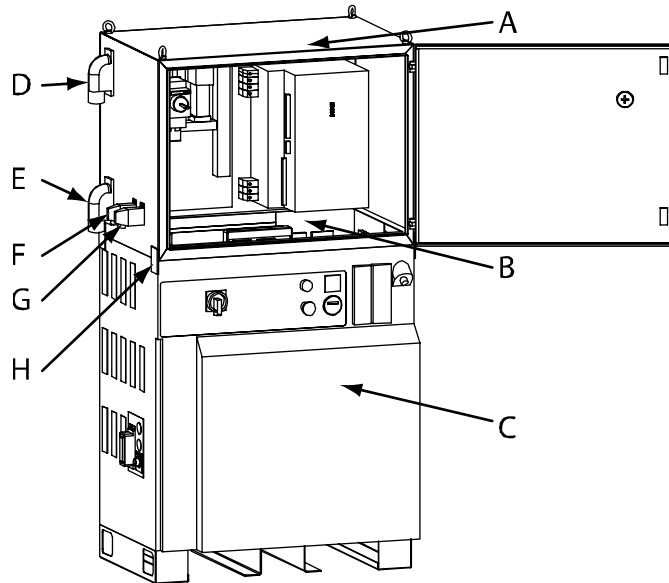

xx0300000126

Parts

Item	Description	Art. no.	Rem.
A	Power unit, AC, type S	3HAC 16704-1	
A	Power unit, AC, type S	3HAC 16704-2	Forced cooling
A	Power unit, AC, type S	3HAC 16704-3	Contactors
A	Power unit, AC, type S	3HAC 16704-4	Earth fault protection
A	Power unit, AC, type S	3HAC 16704-5	Forced cooling Contactors
A	Power unit, AC, type S	3HAC 16704-6	Forced cooling Earth fault protection
A	Power unit, AC, type S	3HAC 16704-7	Forced cooling Contactors Earth fault protection
A	Power unit, AC, type S	3HAC 16704-8	Contactors Earth fault protection
A	Power unit, AC, type HS	3HAC 16705-1	
A	Power unit, AC, type HS	3HAC 16705-2	Forced cooling
A	Power unit, AC, type HS	3HAC 16705-3	Contactors
A	Power unit, AC, type HS	3HAC 16705-4	Earth fault protection

5 Spare Parts

5.8.1. Power unit, std

Item	Description	Art. no.	Rem.
A	Power unit, AC, type HS	3HAC 16705-5	Forced cooling Contactor
A	Power unit, AC, type HS	3HAC 16705-6	Forced cooling Earth fault protection
A	Power unit, AC, type HS	3HAC 16705-7	Forced cooling Contactor Earth fault protection
A	Power unit, AC, type HS	3HAC 16705-8	Contactor Earth fault protection
A	Power unit, MFDC, type S	3HAC 16706-1	Forced cooling
A	Power unit, MFDC, type S	3HAC 16706-2	Forced cooling Contactor
A	Power unit, MFDC, type S	3HAC 16706-3	Forced cooling Earth fault protection
A	Power unit, MFDC, type S	3HAC 16706-4	Forced cooling Contactor Earth fault protection
A	Power unit, MFDC, type HS	3HAC 16707-1	Forced cooling
A	Power unit, MFDC, type HS	3HAC 16707-2	Forced cooling Contactor
A	Power unit, MFDC, type HS	3HAC 16707-3	Forced cooling Earth fault protection
A	Power unit, MFDC, type HS	3HAC 16707-4	Forced cooling Contactor Earth fault protection

Foldout 1

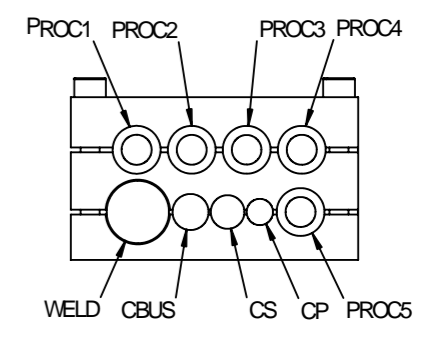
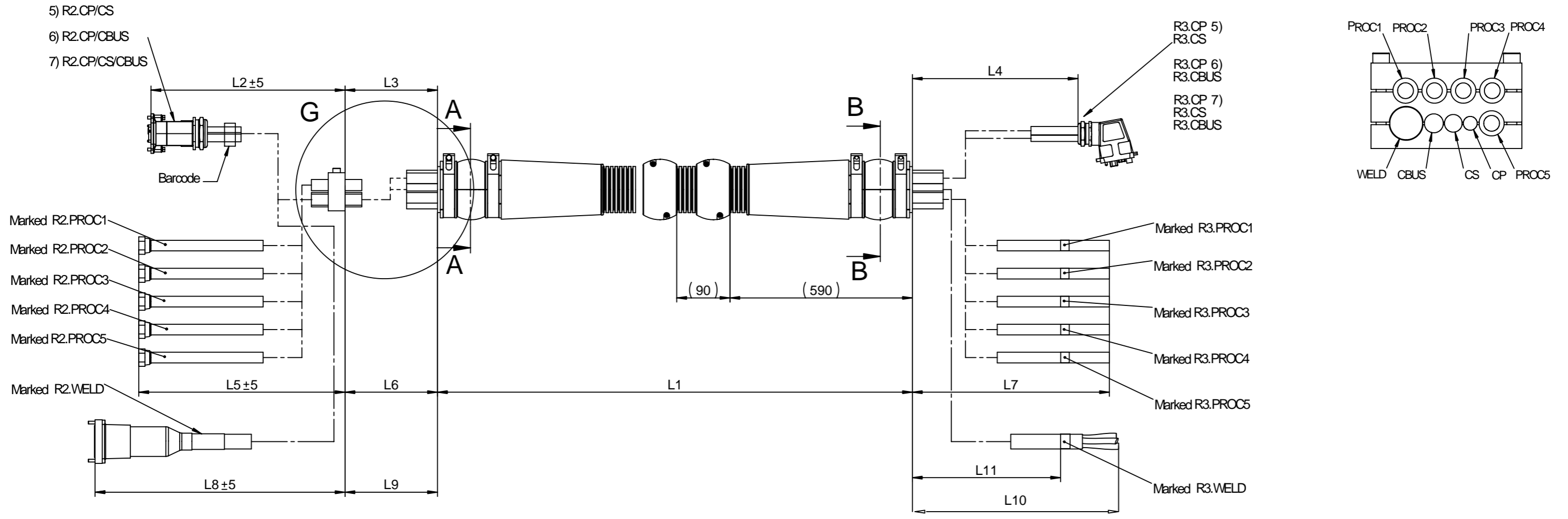

Unless otherwise stated: Tolerance ±10 mm

	Axis 3	Robot 2,55m Robot 2,75m			Robot 2,8m Robot 3,0m Robot 3,2m		Axis 6
Cables/Hoses	L1		2100	2350	2550		
CP/CS/CBus	L2	440					
CP/CS/CBus	L3	1000					
CP/CS/CBus	L4					1000	
Hoses Proc1-4	L5	425					
Hose Proc5	L5	440					
Hoses Proc1-4	L6	1040					
Hose Proc5	L6	1025					
Hoses air	L7					1000	
SW-cable	L8	420					
SW-cable	L9	980					
SW-cable	L10					1150	
Marking	L11					400	

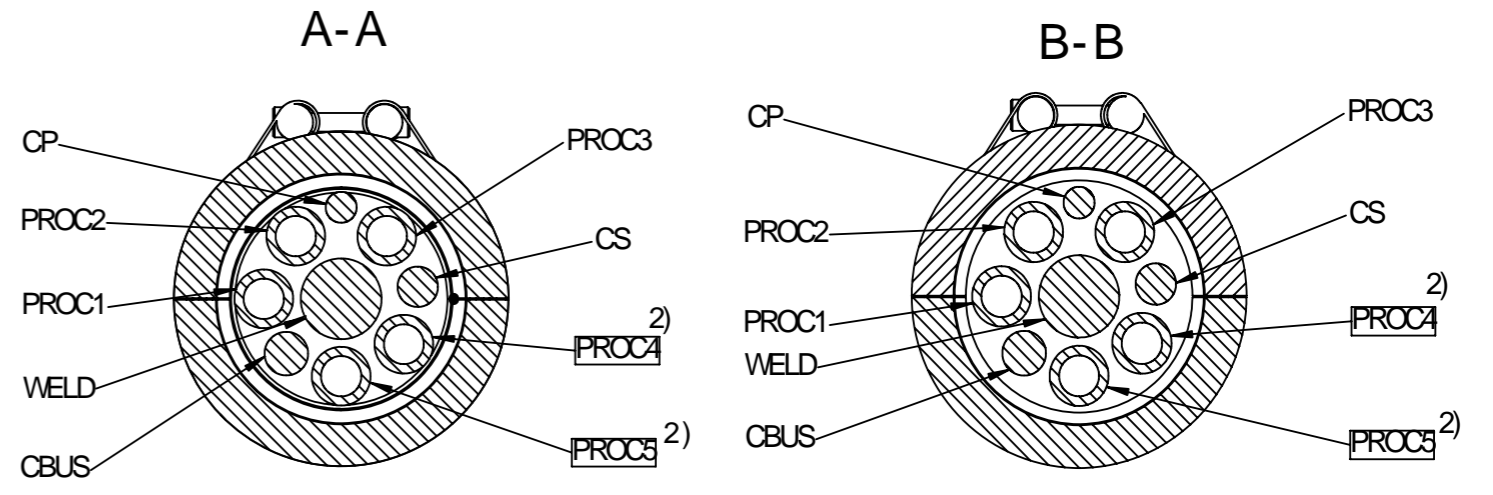
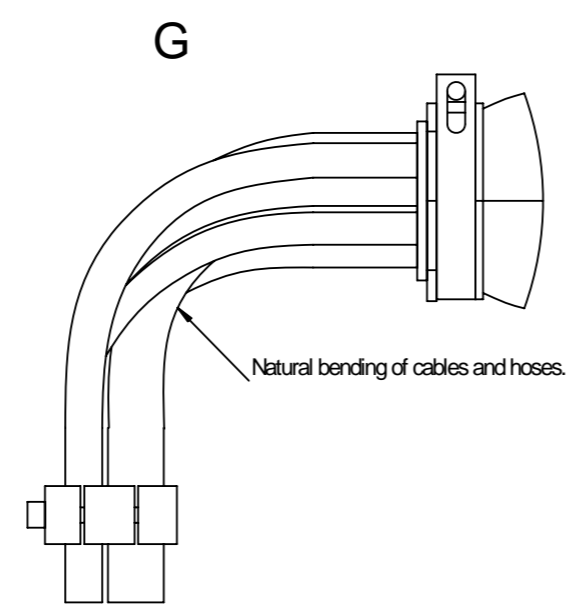

²⁾ PROC4 and PROC5 depend on how many hoses is spec. in parts list.

Foldout 2

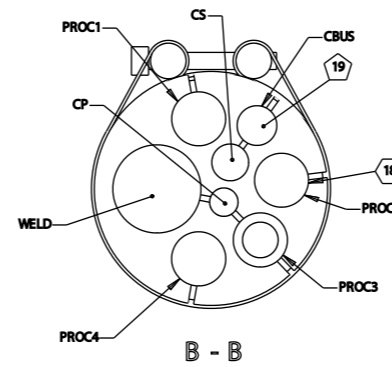
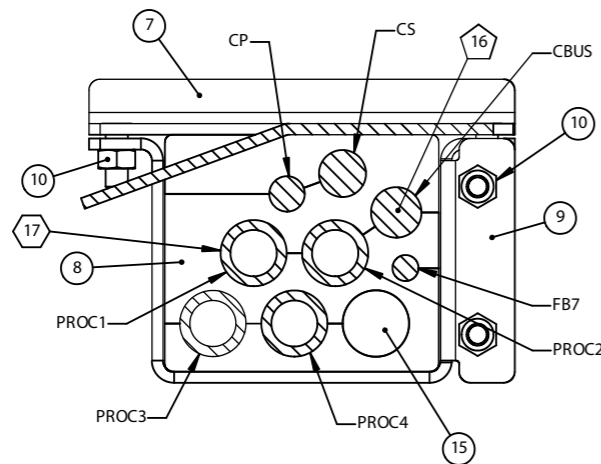
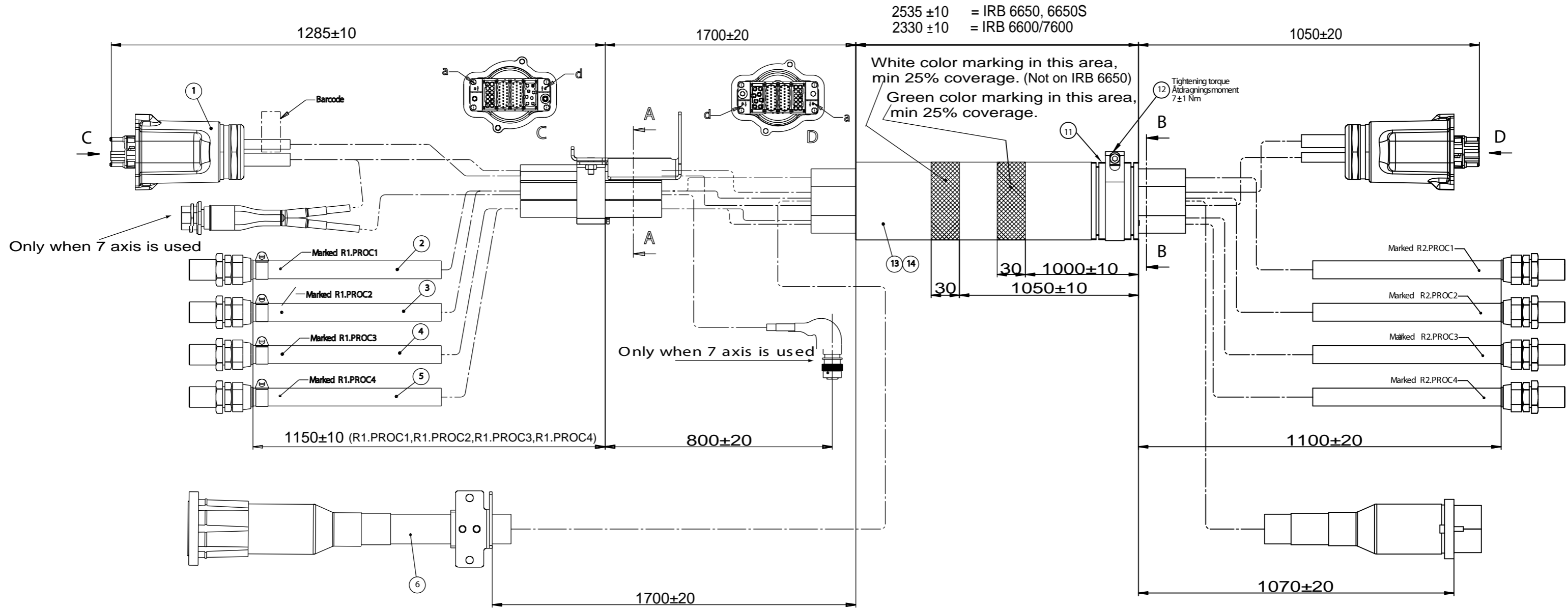

NOTE!

Green color marking is position for upper attachment on IRB 6600, 6650, 6650S.

White color marking is position for upper attachment on IRB 7600.

A

CHAPTER CONTENTS



0	GENERAL INFORMATION
1	BLOCK DIAGRAM
2	CABINET LAYOUT
3	PART LIST, PART LIST OUTSIDE CABINET AND OPTION LIST
4	MAIN CIRCUITS
5	CONTROL CIRCUITS
6	CONTROL CIRCUITS PROCESS EQUIPMENT
7	I/O CIRCUITS
9	CABLES AND EXTERNAL CONNECTIONS

B

C

D

We reserve all rights in this document and in the information contained therein. Reproduction, use or disclosure to third parties without express authority is strictly forbidden. © Copyright 2003 ABB

Prepared by, date C Blanksvärd, 050218	Responsible department ATMA/RO/AB	Description ACC Circuit Diagram	
Approved by, date M Thunell, 050406	Take over department		
Status Approved		SpotPack for servo gun SpotPack för servotång	Sheet 000 No. of sh. 975
 ABB Automation Technologies AB		Document No. 3HAC17669-1	Rev. ind. 03

1 BLOCK DIAGRAM

SHEET CONTENTS

- 101 BLOCK DIAGRAM ROBOT MOUNTED GUN, TYPE Se
- 102 BLOCK DIAGRAM PEDESTAL GUN, TYPE HSe
- 103 BLOCK DIAGRAM CONNECTOR LAYOUT, TYPE S/HS
- 104 BLOCK DIAGRAM POWER UNIT
- 105 BLOCK DIAGRAM WATER AND AIR UNIT

We reserve all rights in this document and in the information contained therein. Reproductions, use or disclosure to third parties without express authority is strictly forbidden. © Copyright 2003 ABB

Prepared by, date C Blanksvärd, 050316	Responsible department ATMA/R0/AB	Description ACC Circuit Diagram	
Approved by, date M Thunell, 050406	Take over department		
Status Approved		SpotPack for servo gun SpotPack för servotång	Sheet 100 No. of sh. 975
Document No. ABB ABB Automation Technologies AB		3HAC17669-1	Rev. ind. 03

BLOCK DIAGRAM TYPE Se

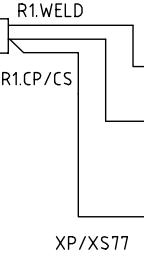
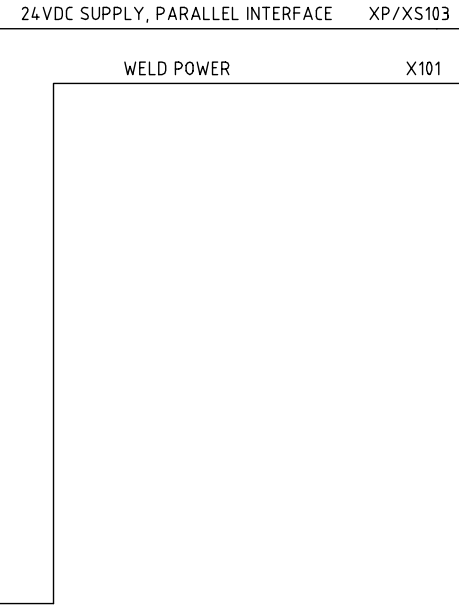
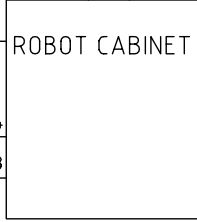
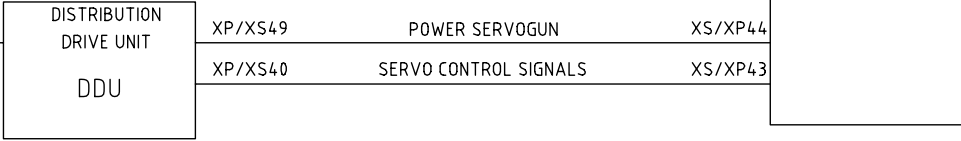
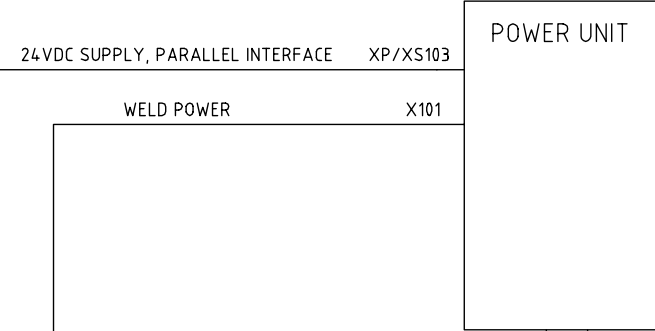
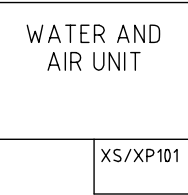
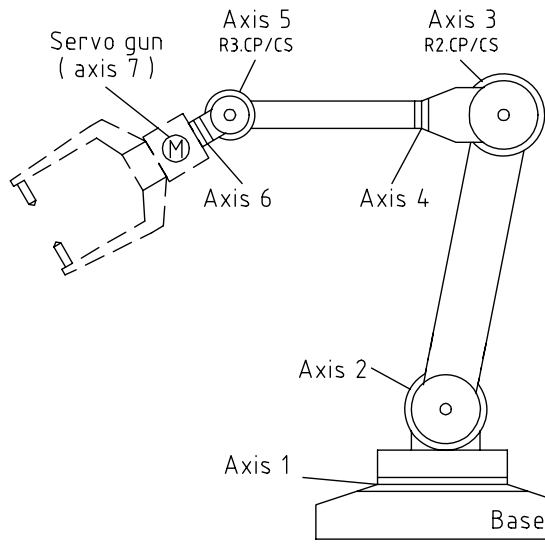

Prepared by, date C Blanksvärd, 050316	Responsible department ATMA/RO/AB	Description ACC SpotPack for servo gun SpotPack för servotång	Circuit Diagram
Approved by, date M Thunell, 050406	Take over department		
Status Approved		Document No. 3HAC17669-1	Sheet 101 No. of sh. 975 Rev. ind. 03

ROBOT MOUNTED GUN /TYPE Se
BLOCK DIAGRAM
IRB 6600/6650/7600

Latest Revision

ABB ABB Automation Technologies AB

We reserve all rights in this document and in the information contained therein. Reproduction, use or disclosure to third parties without express authority is strictly forbidden. © Copyright 2015 ABB

BLOCK DIAGRAM TYPE HSe

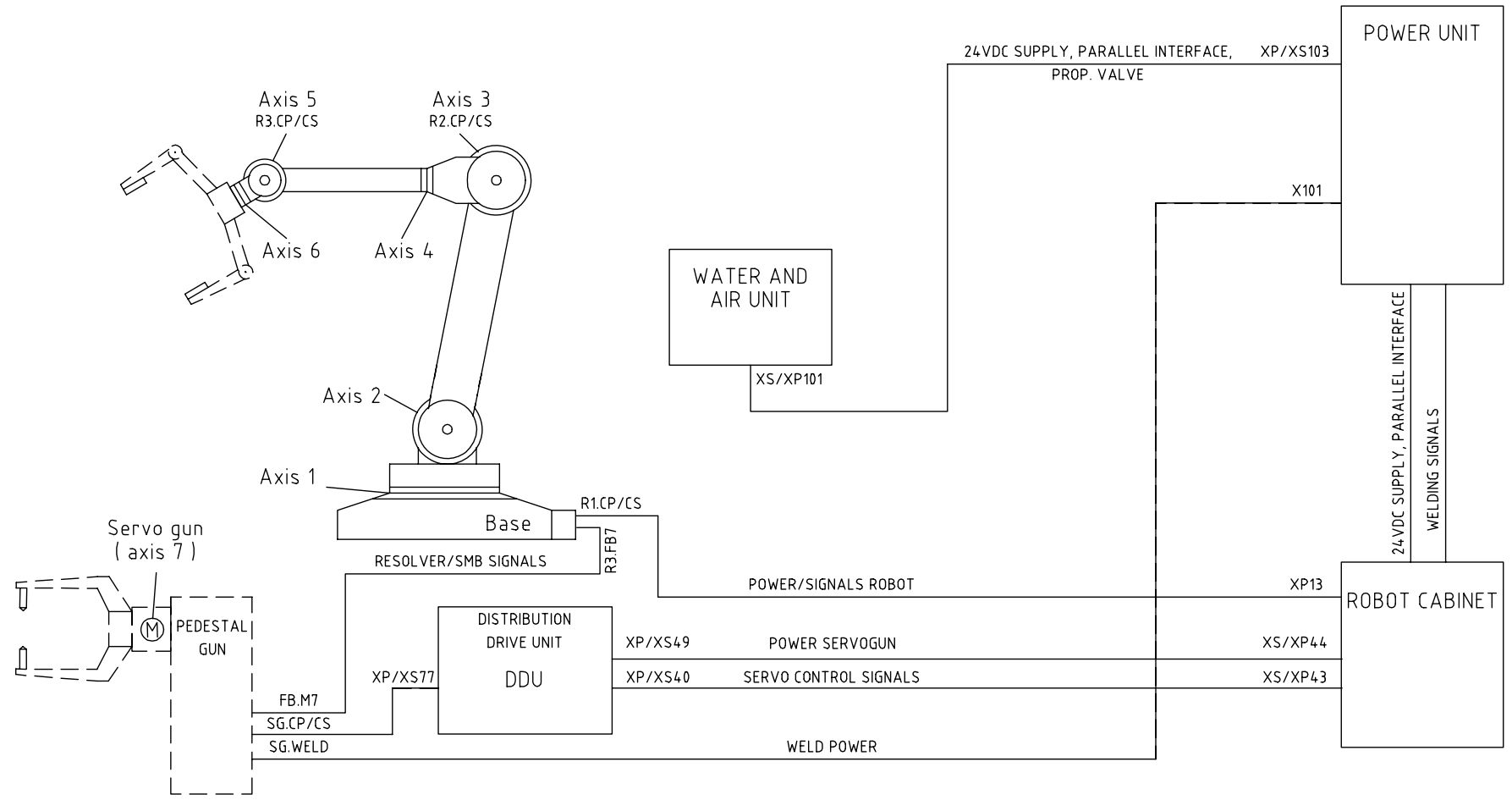

PEDESTAL GUN /TYPE HSe
 BLOCK DIAGRAM
 IRB 6600/6650/7600

Latest Revision

Prepared by, date C Blanksvård, 050316	Responsible department ATMA/RO/AB	Description ACC SpotPack for servo gun SpotPack för servotång	Circuit Diagram
Approved by, date M Thunell, 050406	Take over department		
Status Approved		Document No. 3HAC17669-1	Sheet 102 No. of sh. 953 Rev. ind. 03

ABB ABB Automation Technologies AB

BLOCK DIAGRAM TYPE Se/HSe

Male (R1.CP/CS)

Axis 6 (CP/CS)

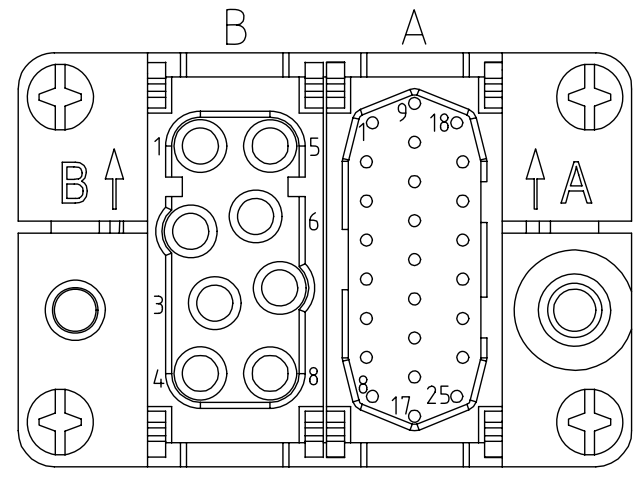
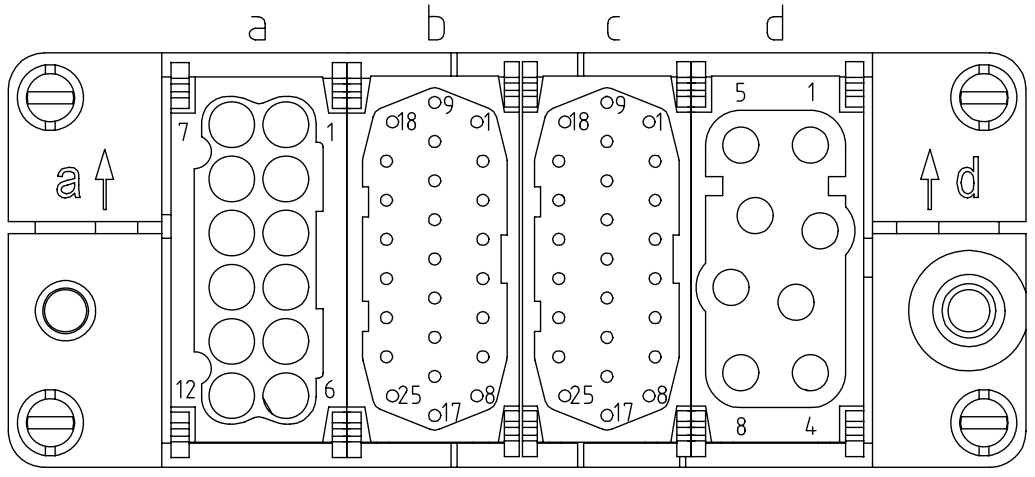

HARTING HAN MODULE/ DD HD HD EE

EE HD

Female (R2.CP/CS)

Axis 6 (CP/Cbus)

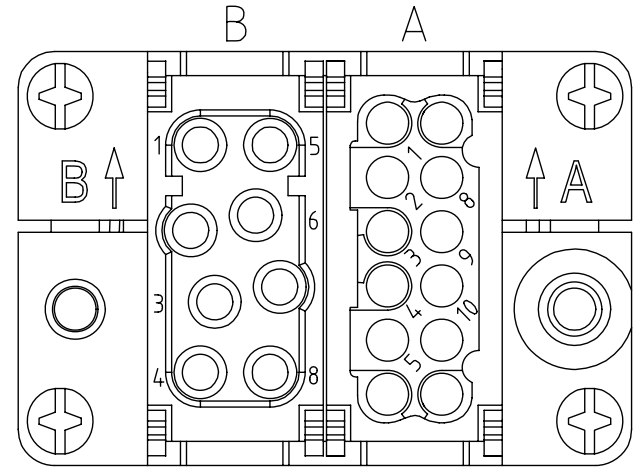
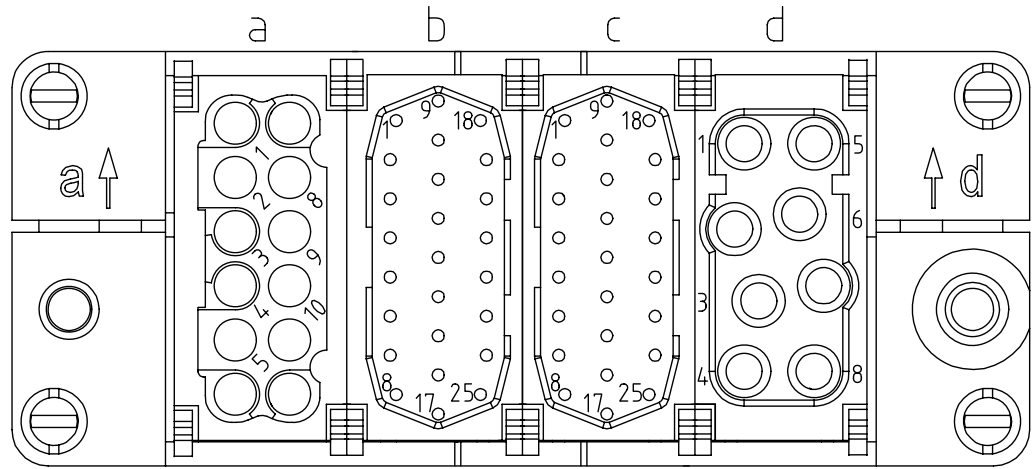

HARTING HAN MODULE/ DD HD HD EE

EE DD

We reserve all rights in this document and in the information contained therein. Reproduction, use or disclosure to third parties without express authority is strictly forbidden. © Copyright 2015 ABB

POWER UNIT
BLOCK DIAGRAM
IRB 6600/6650/7600

Latest Revision

Prepared by, date C Blanksvärd, 050316	Responsible department ATMA/RO/AB	Description ACC SpotPack for servo gun SpotPack för servotång	Circuit Diagram
Approved by, date M Thunell, 050406	Take over department		
Status Approved		Document No. 3HAC17669-1	Sheet 103 No. of sh. 975 Rev. ind. 03

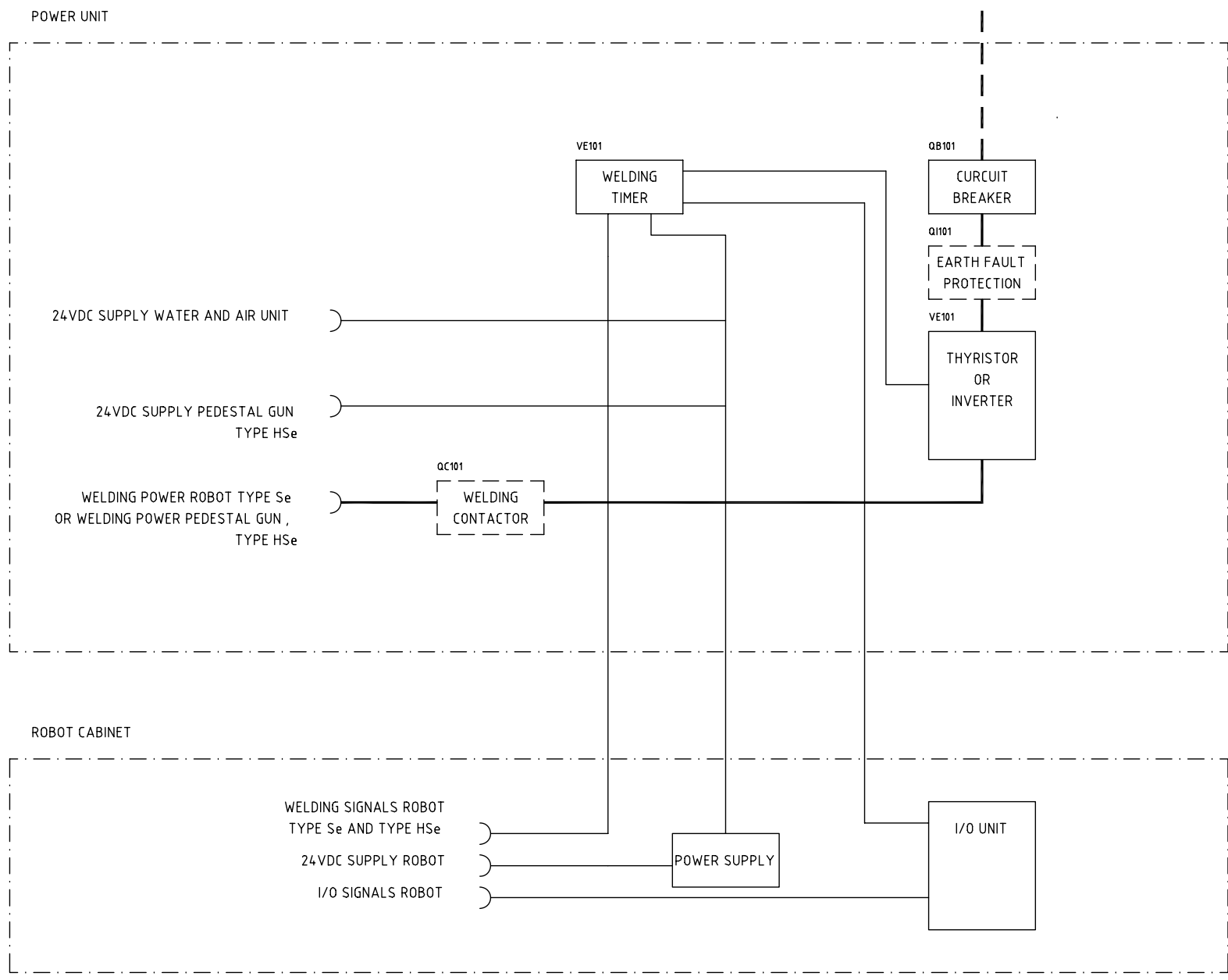

ABB ABB Automation Technologies AB

We reserve all rights in this document and in the information contained therein. Reproduction, use or disclosure to third parties without express authority is strictly forbidden. © Copyright 2003 ABB



POWER UNIT
 BLOCK DIAGRAM
 IRB 6600/6650/7600

Latest Revision

Prepared by, date C Blanksvärd, 050316	Responsible department ATMA/RO/AB	Description ACC SpotPack for servo gun SpotPack för servotång	 Sheet 104 No. of sh. 975 Rev. ind. 03
Approved by, date M Thunell, 050406	Take over department		
Status Approved		Document No. 3HAC17669-1	
 ABB Automation Technologies AB			

WATER AND AIR UNIT FOR ROBOT MOUNTED GUN OR PEDESTAL GUN

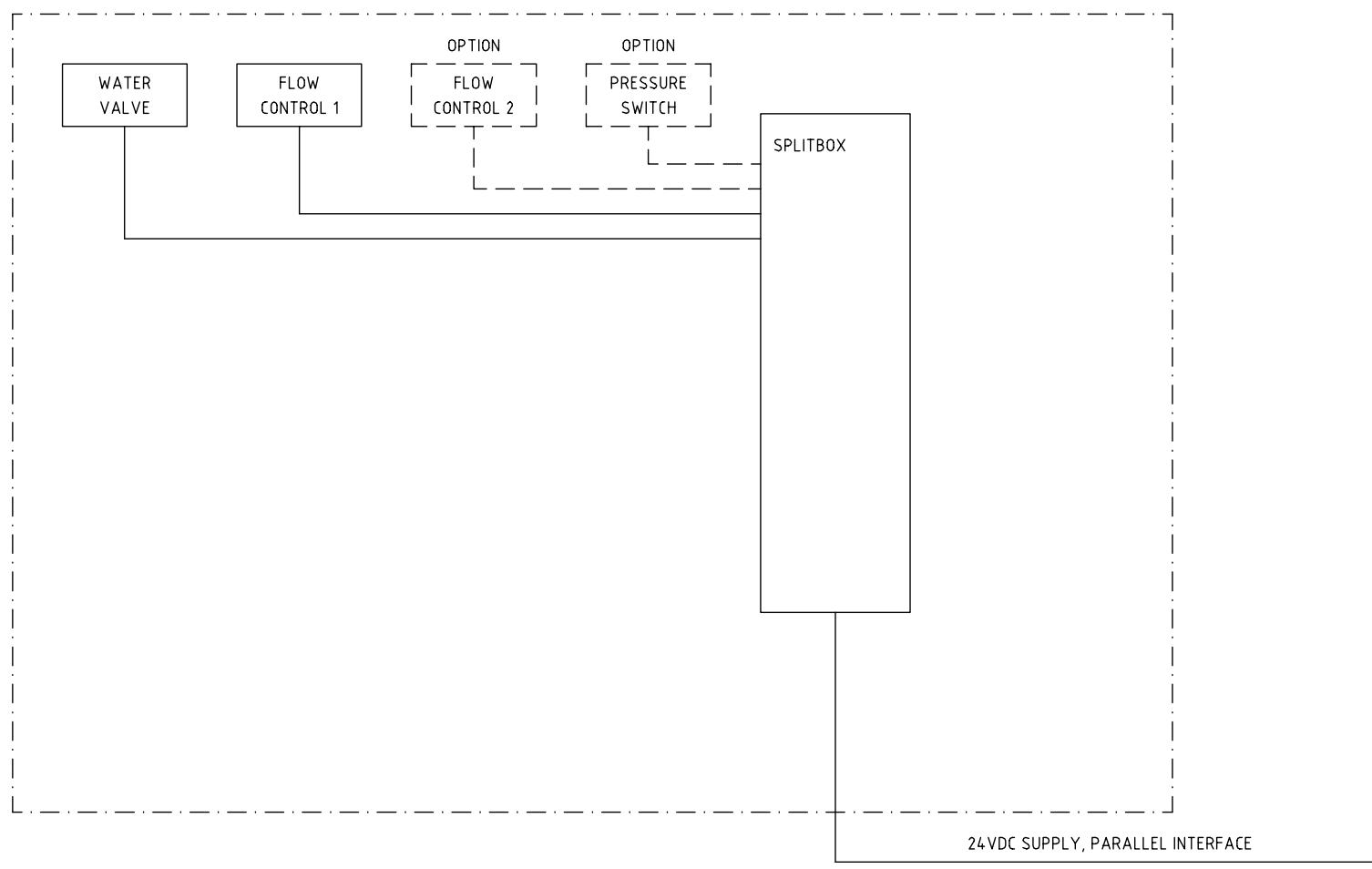

We reserve all rights in this document and in the information contained therein. Reproduction, use or disclosure to third parties without express authority is strictly forbidden. © Copyright 2005 ABB

WATER AND AIR UNIT
BLOCK DIAGRAM
IRB 6600/6650/7600

Latest Revision

Prepared by, date C Blanksvärd, 050316	Responsible department ATMA/R0/AB	Description ACC SpotPack for servo gun SpotPack för servotång	Circuit Diagram
Approved by, date M Thunell, 050406	Take over department		
Status Approved	Document No. 3HAC17669-1		Sheet 105 No. of sh. 975 Rev. ind. 03

ABB ABB Automation Technologies AB

A

2 CABINET LAYOUT

SHEET CONTENTS

201 CABINET LAYOUT

202 CABINET LAYOUT

B

A

B

C

D

We reserve all rights in this document and in the information contained therein. Reproduction, use or disclosure to third parties without express authority is strictly forbidden. © Copyright 2003 ABB

IRB 6600/6650/7600

Latest Revision

Prepared by, date C Blanksvärd, 050316	Responsible department ATMA/R0/AB	Description ACC SpotPack for servo gun SpotPack för servotång	Circuit Diagram 
Approved by, date M Thunell, 050406	Take over department		
Status Approved		Document No. 3HAC17669-1	Sheet 200 No. of sh. 975 Rev. ind. 03

ABB ABB Automation Technologies AB

We reserve all rights in this document and in the information contained therein. Reproduction, use or disclosure to third parties without express authority is strictly forbidden. © Copyright 2015 ABB

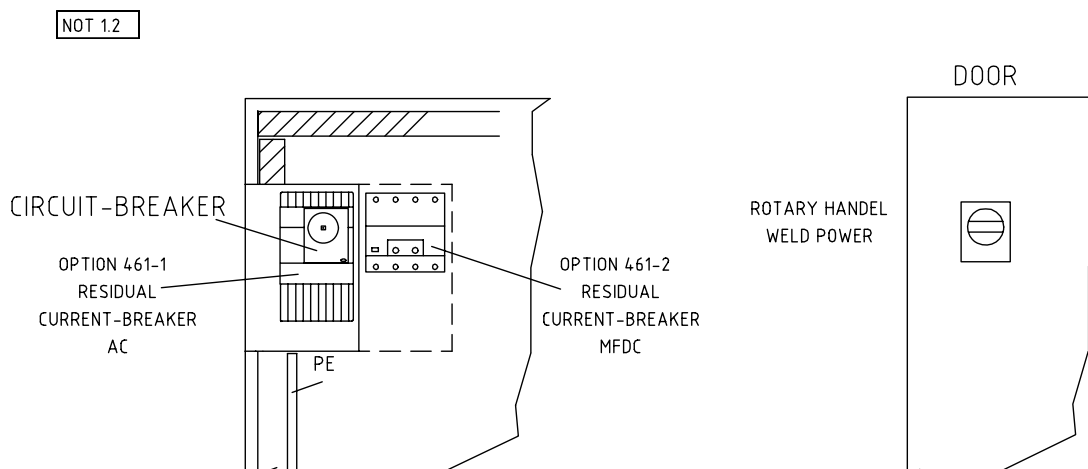
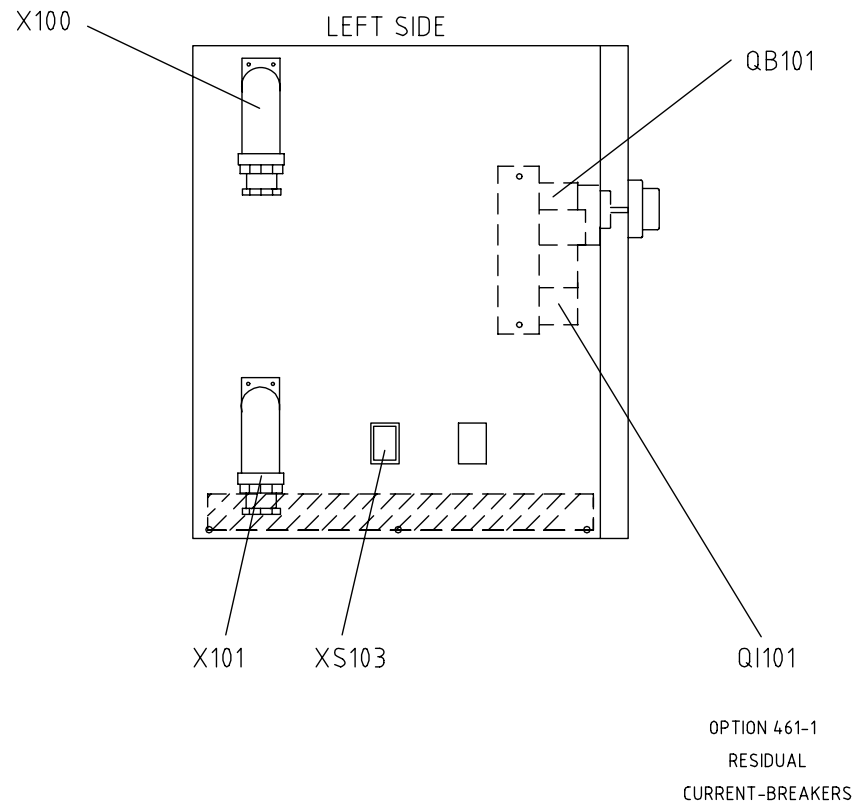
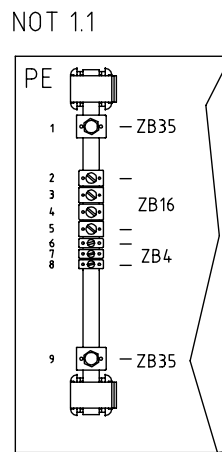
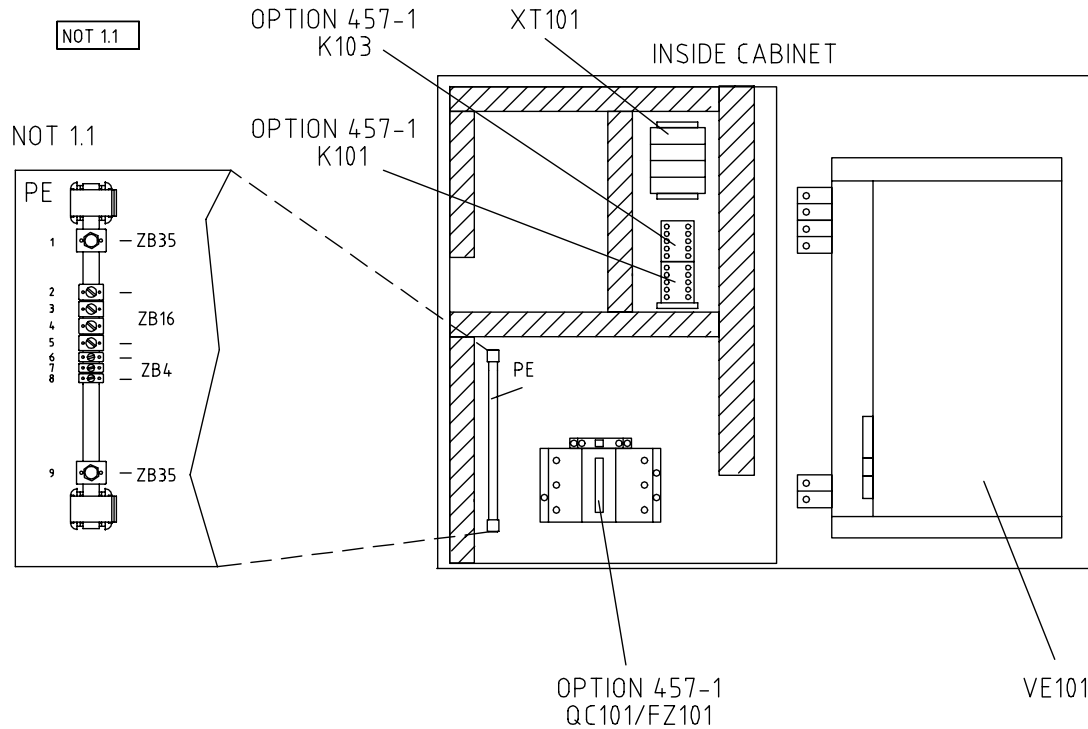

POWER UNIT
CABINET LAYOUT
IRB 6600/6650/7600

Latest Revision

Prepared by, date C Blanksvärd, 050316	Responsible department ATMA/RO/AB	Description ACC SpotPack for servo gun SpotPack för servotång	Circuit Diagram
Approved by, date M Thunell, 050406	Take over department		
Status Approved		Document No. 3HAC17669-1	Sheet 201 No. of sh. 975 Rev. ind. 03

ABB ABB Automation Technologies AB

We reserve all rights in this document and in the information contained therein. Reproduction, use or disclosure to third parties without express authority is strictly forbidden. © Copyright 2015 ABB

A

B

C

D

1

2

3

4

5

6

BACKSIDE

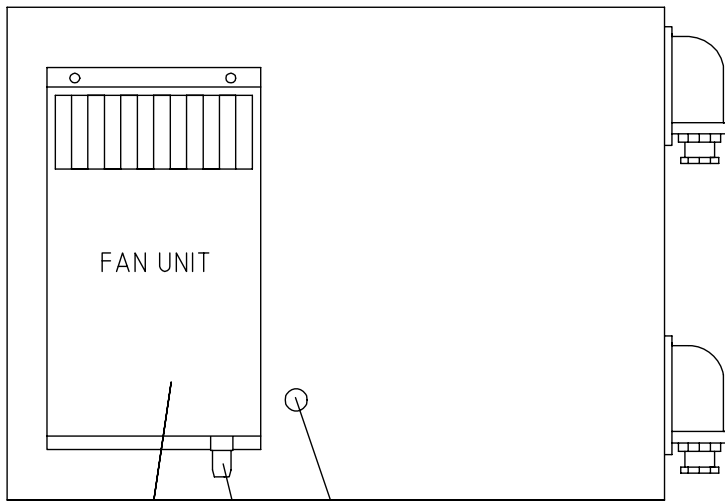

FU100 XP/XS100 X103

OPTION 464-1
 COOLING FAN FOR WELDING INVERTER
 OR THYRISTOR , INCLUDE CONNECTOR XP/XS100
 AND X103 CABLE GLAND

POWER UNIT
 CABINET LAYOUT
 IRB 6600/6650/7600

Latest Revision

Prepared by, date C Blanksvärd, 050316	Responsible department ATMA/R0/AB	Description ACC Circuit Diagram	 Sheet 202
Approved by, date M Thunell, 050406	Take over department		
Status Approved	Document No. 3HAC17669-1		Rev. ind. 03

ABB ABB Automation Technologies AB

1

2

3

4

5

6

A

3 PART LIST, PART LIST OUTSIDE CABINET AND OPTION LIST

SHEET CONTENTS

- 301 PART LIST, POWER UNIT
- 302 ADJUSTMENT PROCEEDING
- 303 PART LIST OUTSIDE CABINET
- 304 OPTION LIST

B

A

B

We reserve all rights in this document and in the information contained therein. Reproduction, use or disclosure to third parties without express authority is strictly forbidden. © Copyright 2003 ABB

C

C

D

IRB 6600/6650/7600

Latest Revision

Prepared by, date C Blanksvärd, 050316	Responsible department ATMA/R0/AB	Description ACC SpotPack for servo gun SpotPack för servotång	Circuit Diagram 
Approved by, date M Thunell, 050406	Take over department		
Status Approved			Sheet 300
		Document No. 3HAC17669-1	No. of sh. 975
	ABB Automation Technologies AB		Rev. ind. 03

We reserve all rights in this document and in the information contained therein. Reproduction, use or disclosure to third parties without express authority is strictly forbidden. © Copyright 2005 ABB

POS	QUANTITY	DESCRIPTION	PRODUCT/ SUPPLIER	TYPE/ DATA	REMARK
<i>Components in power cabinet.</i>					
	1	CABINET	ABB	FDLN 528301-KV	600x800x530 mm
QB101	1	CIRCUIT-BREAKER (MAIN SWITCH)	ABB	T1N 160 F FC Cu R125	WELDING POWER ONLY
	1	AUXILIARY CONTACTS	ABB	TYPE AUX	
	1	ROTARY HANDLE	ABB	NORMAL RHE	
(QI101)	1	RESIDUAL CURRENT -BREAKER	ABB	RC 221/1 50-60Hz RC 212/1 50-5000Hz	Ver. 50-5000Hz if MFDC is used
VE101	1	THYRISTOR OR INVERTER	BOSCH	*	* SEE OPTION LIST
(FU100)	1	FAN UNIT	ABB	5DLN529201-GV	
(X103)	1	CABEL GLAND		CABEL GLAND M16 + NUT	COOLING FAN
(QC101)	1	(WELDING) CONTACTOR	ABB	A110-30-11 220-230V 50-60 Hz	
	1	AUXILIARY CONTACTS	ABB	CAL5-11	
(FZ101)	1	SURGE SUPPRESSOR	ABB	RC-EH250/415 110-415V	
(K101)	1	INTERFACE CONTACTOR RELAY	ABB	K6S-40E1,7	WITH DIODE
(K103)	1	INTERFACE CONTACTOR RELAY	ABB	K6S-40E1,7	WITH DIODE
X100	1	GLAND PLATES + CABLE GLAND		FLV 13140 + CABLE GLAND 40mm	CABLE DIM.23-34 MM
X101	1	GLAND PLATES + CABLE GLAND		FLV 13140 + CABLE GLAND 40mm	CABLE DIM.23-34 MM
XT101	4	TERMINALFUSE 24Vdc	WEIDMÜLLER	WSI 6	SUPPLY 24Vdc (2AT)
	4	TERMINAL	WEIDMÜLLER	WDU 2.5	
XS103	1	CONNECTOR	HARTING	HOUSING	WATER AND AIR UNIT
	1			HAN DD MODULE / 12-Pol	
	7			FEMALE CONTACT	

POWER UNIT
PART LIST
IRB 6600/6650/7600

Latest Revision

Prepared by, date C Blanksvård, 050316	Responsible department ATMA/R0/AB	Description ACC SpotPack for servo gun SpotPack för servotång	Circuit Diagram 
Approved by, date M Thunell, 050406	Take over department		
Status Approved		Document No. 3HAC17669-1	Sheet 301 No. of sh. 975 Rev. ind. 03

ABB ABB Automation Technologies AB

4 MAIN CIRCUITS

SHEET CONTENTS

401 MAIN CIRCUITS

We reserve all rights in this document and in the information contained therein. Reproduction, use or disclosure to third parties without express authority is strictly forbidden. © Copyright 2003 ABB

Prepared by, date C Blanksvärd, 050316	Responsible department ATMA/R0/AB	Description ACC Circuit Diagram 	Sheet 400
Approved by, date M Thunell, 050406	Take over department		No. of sh. 975
Status Approved		Document No. 3HAC17669-1	Rev. ind. 03

We reserve all rights in this document and in the information contained therein. Reproduction, use or disclosure to third parties without express authority is strictly forbidden. © Copyright 2005 ABB

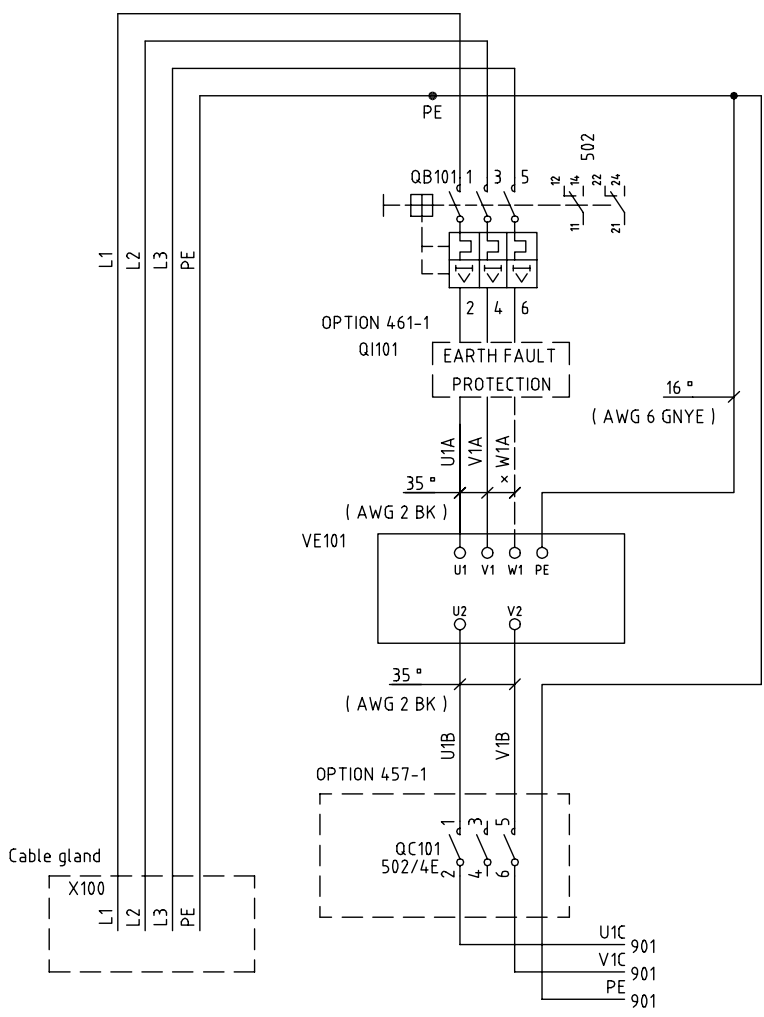

MIN AND MAX VOLTAGE
 FOR THYRISTOR 400-600 VAC
 FOR INVERTER 400-480 VAC
 MAX CURRENT FEED 160 A
 MAX SHORT-CIRCUIT-CURRENT 35kA

WELD POWER 1
 110A RMS

×W1A USED WITH MFDC INVERTERS

CABLE COLOR

L1 , L2 , L3	BLACK
NEUTRAL	GREY
230 VAC CONTR. CIRC.	GREY
24 VDC CONTR. CIRC.	BLUE
GROUND / PE	GREEN/YELLOW

POWER UNIT
 MAIN CIRCUIT
 IRB 6600/6650/7600

Latest Revision

Prepared by, date C Blanksvård, 050316	Responsible department ATMA/R0/AB	Description ACC Circuit Diagram	
Approved by, date M Thunell, 050406	Take over department		
Status Approved	SpotPack for servo gun SpotPack för servotång		Sheet 401 No. of sh. 975 Rev. ind. 03
ABB Automation Technologies AB		Document No. 3HAC17669-1	

5	CONTROL CIRCUIT
SHEET	CONTENTS
501	POWER SUPPLY 24VDC
502	CONTROL CIRCUIT WELDING CONTACTOR
503	CONTROL CIRCUIT SAFETY

We reserve all rights in this document and in the information contained therein. Reproduction, use or disclosure to third parties without express authority is strictly forbidden. © Copyright 2013 ABB

IRB 6600/6650/7600

Latest Revision

Prepared by, date C Blanksvärd, 050316	Responsible department ATMA/RO/AB	Description ACC Circuit Diagram 	Sheet 500
Approved by, date M Thunell, 050406	Take over department		No. of sh. 975
Status Approved		Document No. 3HAC17669-1	Rev. ind. 03

ABB ABB Automation Technologies AB

We reserve all rights in this document and in the information contained therein. Reproduction, use or disclosure to third parties without express authority is strictly forbidden. © Copyright 2015 ABB

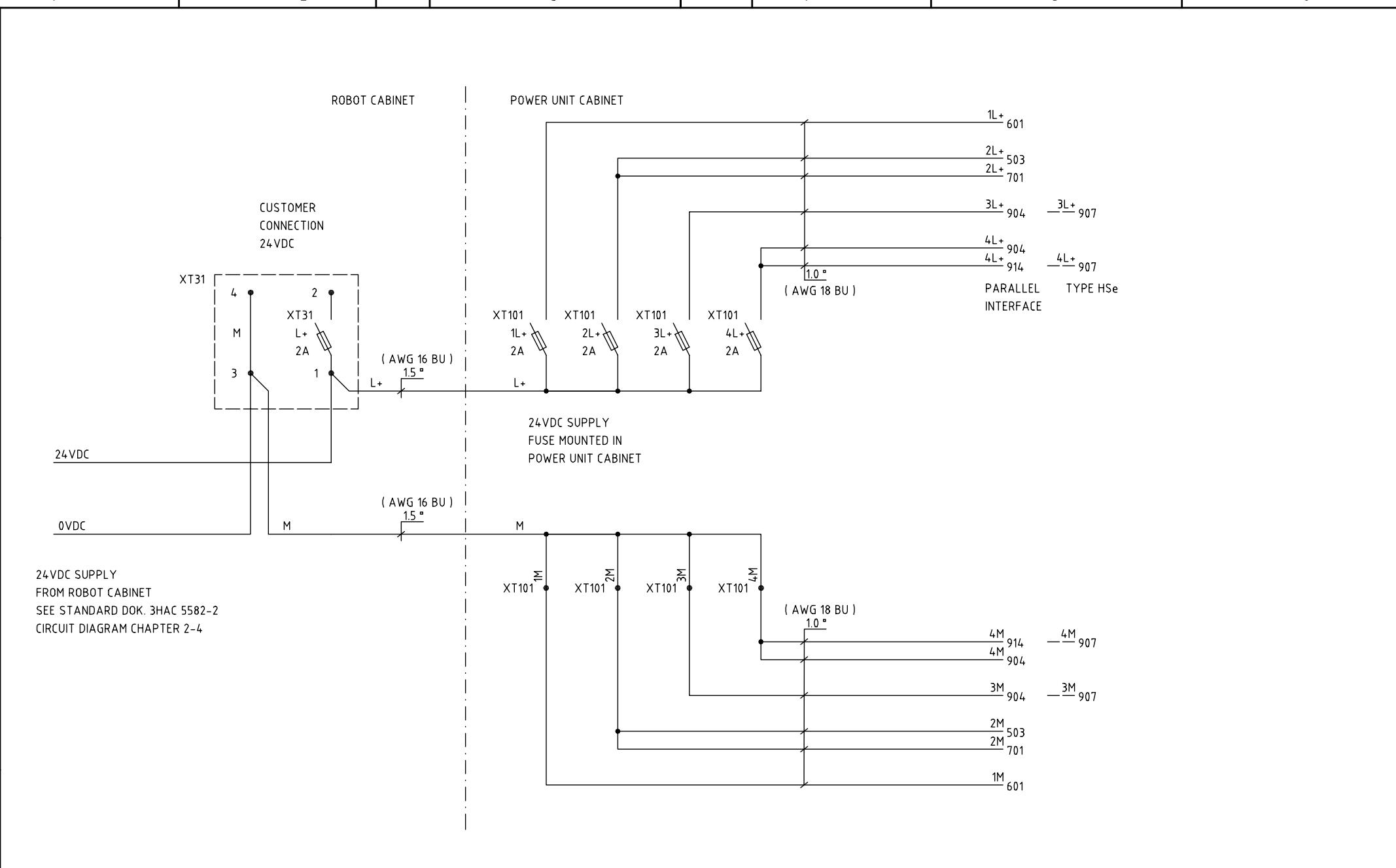

POWER UNIT
POWER SUPPLY 24VDC
IRB 6600/6650/7600

Latest Revision

Prepared by, date C Blanksvärd, 050316	Responsible department ATMA/RO/AB	Description ACC Circuit Diagram	
Approved by, date M Thunell, 050406	Take over department		
Status Approved		SpotPack for servo gun SpotPack för servotång	Sheet 501 No. of sh. 975 Rev. ind. 03
ABB Automation Technologies AB		Document No. 3HAC17669-1	

ROBOT CABINET

POWER UNIT CABINET

SUPPLY FROM
ROBOT CABINET
XT21 (TRAF0 SUPPLY)
SEE STANDARD DOK 3HAC 5582-2
CIRCUIT DIAGRAM CHAPTER 8

OPTION 457-1
CONTACTOR FOR WELD POWER

QB101
401

K101
701

QC101

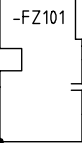

WELDING POWER 1
CONTACTOR ON

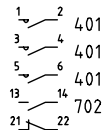

CONTACTOR FOR WELD POWER

We reserve all rights in this document and in the information contained therein. Reproduction, use or disclosure to third parties without express authority is strictly forbidden. © Copyright 2003 ABB

POWER UNIT
CONTROL CIRCUIT WELDING CONTACTORS
IRB 6600/6650/7600

Latest Revision

Prepared by, date C Blanksvärd, 050316	Responsible department ATMA/RO/AB	Description ACC SpotPack for servo gun SpotPack för servotång	Circuit Diagram
Approved by, date M Thunell, 050406	Take over department		
Status Approved		Document No. 3HAC17669-1	Sheet 502 No. of sh. 975 Rev. ind. 03

ABB ABB Automation Technologies AB

STANDARD
CONNECTION CIRCUIT SAFETY

OPTION 457-1
CONTACTOR FOR WELD POWER
CONNECTION CIRCUIT SAFETY

501^{2L+} 2L+

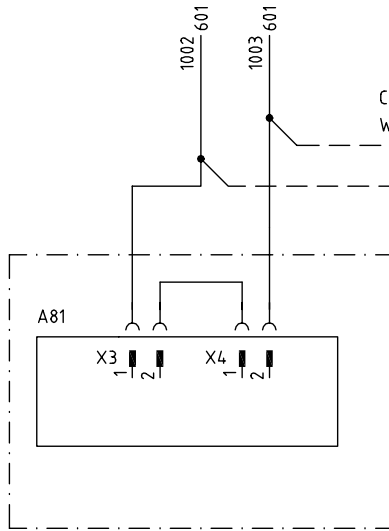

ROBOT CABINET
SEE STANDARD DOK 3HAC 5582-2
CIRCUIT DIAGRAM CHAPTER 4

CONNECTION IF OPTION
WELDING CONTACTOR USED

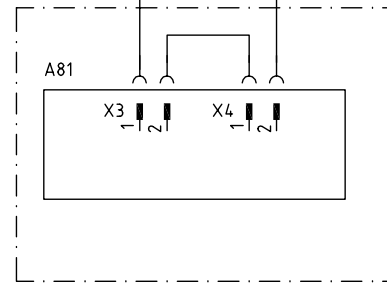
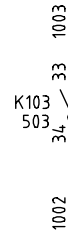

ROBOT CABINET
SEE STANDARD DOK 3HAC 5582-2
CIRCUIT DIAGRAM CHAPTER 4

1001

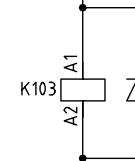

INTERLOCK WELDING

501^{2M} 2M

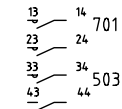

POWER UNIT
CONTROL CIRCUIT SAFETY
IRB 6600/6650/7600

Latest Revision

Prepared by, date C Blanksvård, 050317	Responsible department ATMA/RO/AB	Description ACC SpotPack for servo gun SpotPack för servotång	Circuit Diagram
Approved by, date M Thunell, 050406	Take over department		
Status Approved		Document No. 3HAC17669-1	Sheet 503 No. of sh. 975 Rev. ind. 03

ABB ABB Automation Technologies AB

3HAC17669-1

03

We reserve all rights in this document and in the information contained therein. Reproduction, use or disclosure to third parties without express authority is strictly forbidden. © Copyright 2005 ABB

1 2 3 4 5 6

A

6 CONTROL CIRCUIT PROCESS EQUIPMENT

SHEET CONTENTS

601 CONTROL CIRCUIT BOSCH 6000

B

C

D

No reserve all rights in this document and in the information contained therein. Reproduction, use or disclosure to third parties without express authority is strictly forbidden. © Copyright 2003 ABB

IRB 6600/6650/7600

Latest Revision

Prepared by, date C Blanksvärd, 050316	Responsible department ATMA/R0/AB	Description ACC Circuit Diagram 	Sheet 600
Approved by, date M Thunell, 050406	Take over department		No. of sh. 975
Status Approved	Document No. 3HAC17669-1		Rev. ind. 03

ABB ABB Automation Technologies AB

1 2 3 4 5 6

We reserve all rights in this document and in the information contained therein. Reproduction, use or disclosure to third parties without express authority is strictly forbidden. © Copyright 2003 ABB

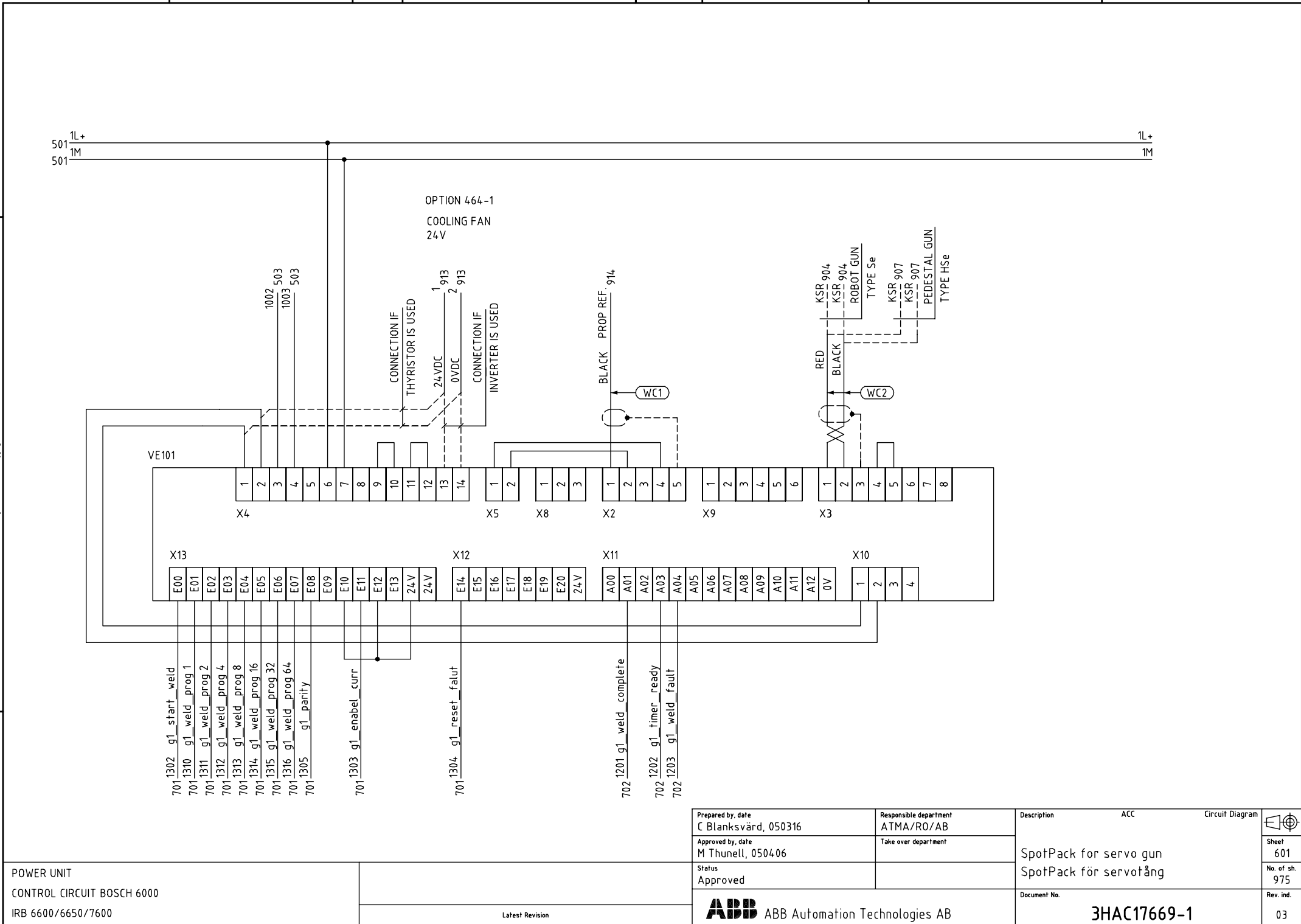

POWER UNIT
CONTROL CIRCUIT BOSCH 6000
IRB 6600/6650/7600

Latest Revision

Prepared by, date C Blanksvård, 050316	Responsible department ATMA/R0/AB	Description ACC SpotPack for servo gun SpotPack för servotång	 Sheet 601 No. of sh. 975 Rev. ind. 03
Approved by, date M Thunell, 050406	Take over department		
Status Approved	Document No. 3HAC17669-1		
ABB Automation Technologies AB			

A

7 I/O UNIT
 SHEET CONTENTS
 701 DIGITAL I/O UNIT 01 OUTPUT
 702 DIGITAL I/O UNIT 01 INPUT

B

C

D

We reserve all rights in this document and in the information contained therein. Reproduction, use or disclosure to third parties without express authority is strictly forbidden. © Copyright 2003 ABB

IRB 6600/6650/7600

Latest Revision

Prepared by, date C Blanksvärd, 050316	Responsible department ATMA/R0/AB	Description ACC SpotPack for servo gun SpotPack för servotång	Circuit Diagram 
Approved by, date M Thunell, 050406	Take over department		
Status Approved	Document No. 3HAC17669-1		Sheet 700 No. of sh. 975 Rev. ind. 03

ABB ABB Automation Technologies AB

We reserve all rights in this document and in the information contained therein. Reproduction, use or disclosure to third parties without express authority is strictly forbidden. © Copyright 2015 ABB

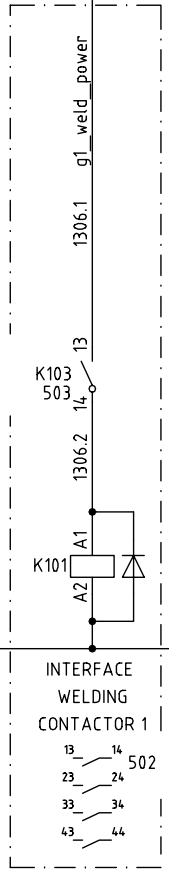
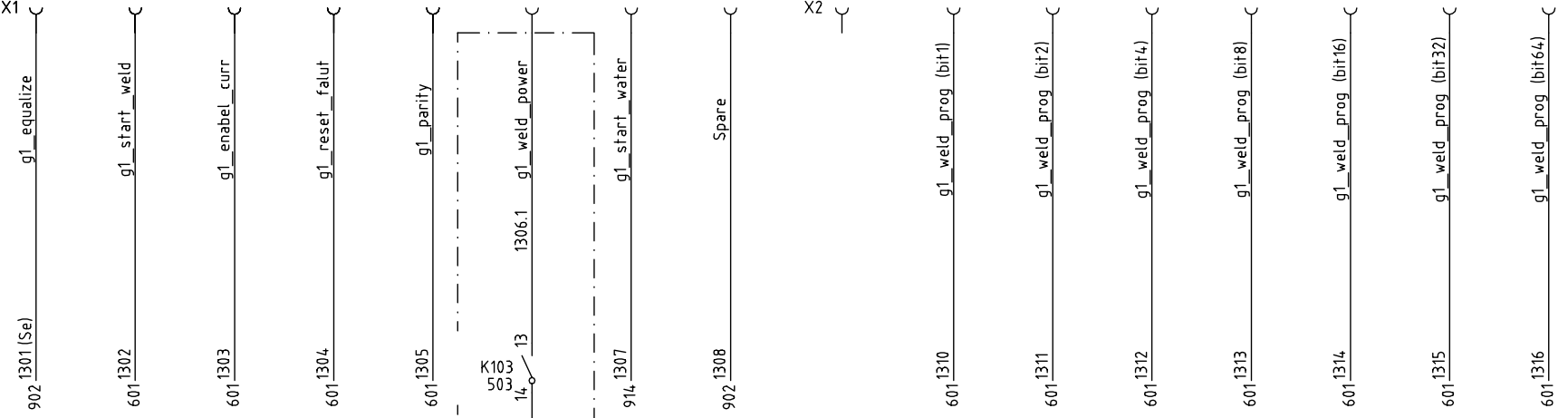
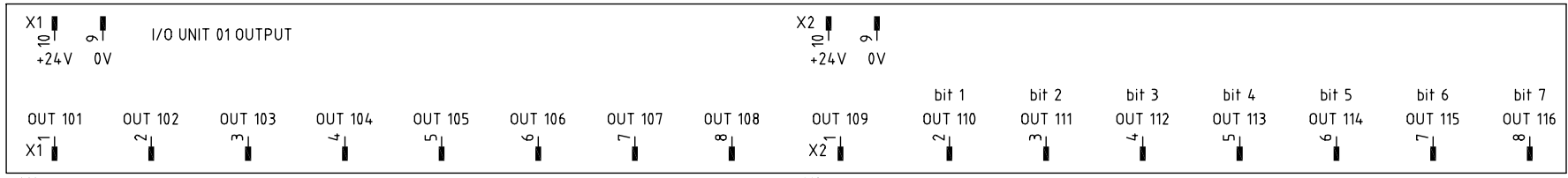
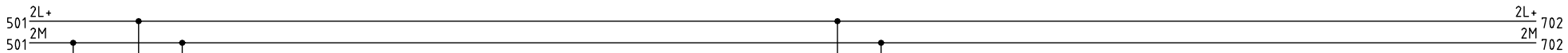

INTERFACE
WELDING
CONTACTOR 1

OPTION 457-1
CONTACTOR FOR WELD POWER
CONNECTION CIRCUIT SAFETY

POWER UNIT
DIGITAL I/O UNIT 01 OUTPUT
IRB 6600/6650/7600

Latest Revision

Prepared by, date C Blanksvård, 050317	Responsible department ATMA/R0/AB	Description ACC SpotPack for servo gun SpotPack för servotång	Circuit Diagram
Approved by, date M Thunell, 050406	Take over department		
Status Approved		Document No. 3HAC17669-1	Sheet 701 No. of sh. 975 Rev. ind. 03

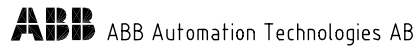

We reserve all rights in this document and in the information contained therein. Reproduction, use or disclosure to third parties without express authority is strictly forbidden. © Copyright 2015 ABB

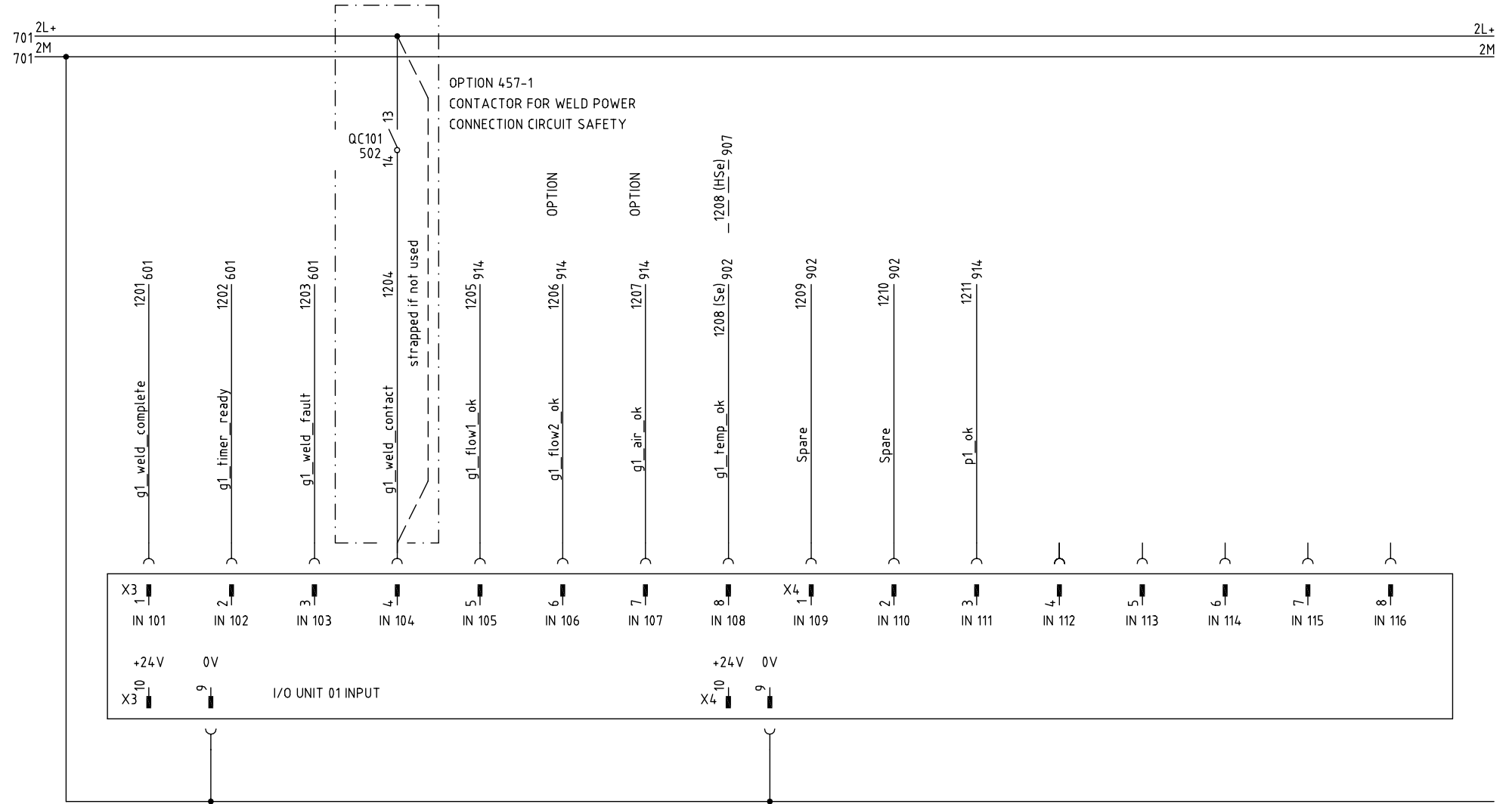

POWER UNIT
DIGITAL I/O UNIT 01 INPUT
IRB 6600/6650/7600

Latest Revision

Prepared by, date C Blanksvärd, 050316	Responsible department ATMA/RO/AB	Description ACC SpotPack for servo gun SpotPack för servotång	Circuit Diagram
Approved by, date M Thunell, 050406	Take over department		
Status Approved		Document No. 3HAC17669-1	Sheet 702 No. of sh. 975 Rev. ind. 03

ABB ABB Automation Technologies AB

9 CABLES AND EXTERNAL CONNECTIONS

SHEET CONTENTS

901	WELD POWER, TYPE Se/HSe
902	CUSTOMER SIGNALS PARALLEL, TYPE Se
903	CUSTOMER POWER/CUSTOMER SIGNALS PARALLEL, TYPE Se
904	CUSTOMER POWER/CUSTOMER SIGNALS PARALLEL, TYPE Se
905	CUSTOMER SIGNALS PARALLEL, TYPE HSe
906	CUSTOMER POWER/CUSTOMER SIGNALS PARALLEL, TYPE HSe
907	CUSTOMER POWER/CUSTOMER SIGNALS PARALLEL, TYPE HSe
908	CUSTOMER POWER/CUSTOMER SIGNALS BASIC PARALLEL, TYPE HSe
909	CUSTOMER POWER/CUSTOMER SIGNALS PARALLEL, PEDESTAL GUN 1, TYPE HSe
910	CUSTOMER POWER/CUSTOMER BUS, CANBUS, TYPE HSe
911	CUSTOMER POWER/CUSTOMER BUS, PROFIBUS, TYPE HSe
912	CUSTOMER POWER/CUSTOMER BUS, INTERBUS, TYPE HSe
913	CUSTOMER POWER, FAN UNIT
914	CUSTOMER POWER/CUSTOMER SIGNALS TO WATER AND AIR UNIT
950	DESIGN CHANGES, NOT 1.1-1.2,1.4-1.5
951	DESIGN CHANGES, NOT 1.6,1.16
952	DESIGN CHANGES, NOT 1.9,1.10
953	DESIGN CHANGES, NOT 1.11,1.12
954	DESIGN CHANGES, NOT 1.13,1.14
955	DESIGN CHANGES, NOT 1.15,1.17
956	DESIGN CHANGES, NOT 1.18
970	LOWER ARM HARNESS: 3HAC020126-001, 3HAC020304-001
971	LOWER ARM HARNESS: 3HAC16782-1, 3HAC16783-1, 3HAC16788-1, 3HAC16789-1
972	LOWER ARM HARNESS: 3HAC020447-001
973	LOWER ARM HARNESS: 3HAC020179-001, 3HAC020303-001
974	UPPER ARM HARNESS: 3HAC16643-1,-2,-3, 3HAC16645-1,-2,-3, 3HAC16647-1-5
975	UPPER ARM HARNESS: 3HAC16644-1,-2,-3, 3HAC16646-1,-2,-3, 3HAC16648-1-5

We reserve all rights in this document and in the information contained therein. Reproduction, use or disclosure to third parties without express authority is strictly forbidden. © Copyright 2015 ABB

Prepared by, date C Blanksvård, 050316	Responsible department ATMA/R0/AB	Description ACC Circuit Diagram	
Approved by, date M Thunell, 050406	Take over department		
Status Approved	SpotPack for servo gun SpotPack för servotång		Sheet 900 No. of sh. 975
Document No. 3HAC17669-1		Rev. ind. 03	

FLOOR HARNESS
3HAC16847-1,-2

POWER UNIT
CABINET

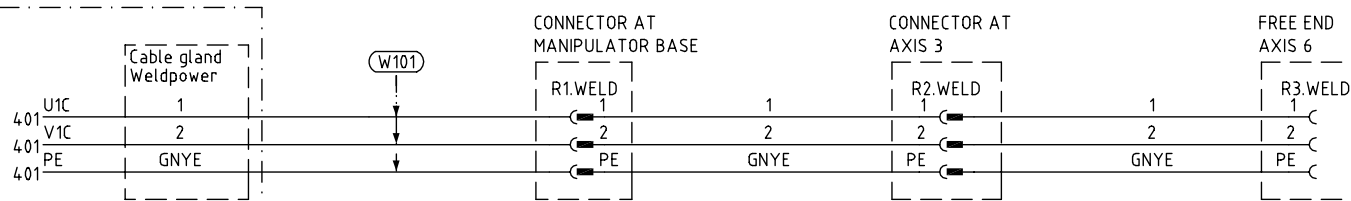

WELD POWER 1 ROBOT MOUNTED GUN
TYPE Se

CONNECTOR AT
PEDESTAL GUN

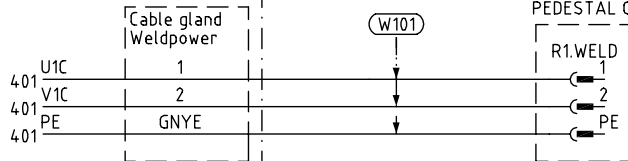

WELD POWER 1 PEDESTAL MOUNTED GUN
TYPE HSe

CABLES AND EXTERNAL CONNECTIONS

IRB 6600/6650/7600

Latest Revision

Prepared by, date C Blanksvärd, 050317	Responsible department ATMA/R0/AB	Description ACC SpotPack for servo gun SpotPack för servotång	Circuit Diagram
Approved by, date M Thunell, 050406	Take over department		
Status Approved		Document No. 3HAC17669-1	Sheet 901 No. of sh. 975 Rev. ind. 03

ABB ABB Automation Technologies AB

TYPE Se

CUSTOMER POWER/
CUSTOMER SIGNALS

PARALLEL
COMMUNICATION

LOWER ARM HARNESS

3HAC16782-1

3HAC16783-1

3HAC16788-1

3HAC16789-1

UPPER ARM HARNESS

3HAC16643-1,-2,-3

3HAC16645-1,-2,-3

CONNECTED TO
XP77, DDU
SEE SIDE 904

CONNECTOR AT
MANIPULATOR BASE

CONNECTOR AT
AXIS 3

CONNECTOR AT
AXIS 6

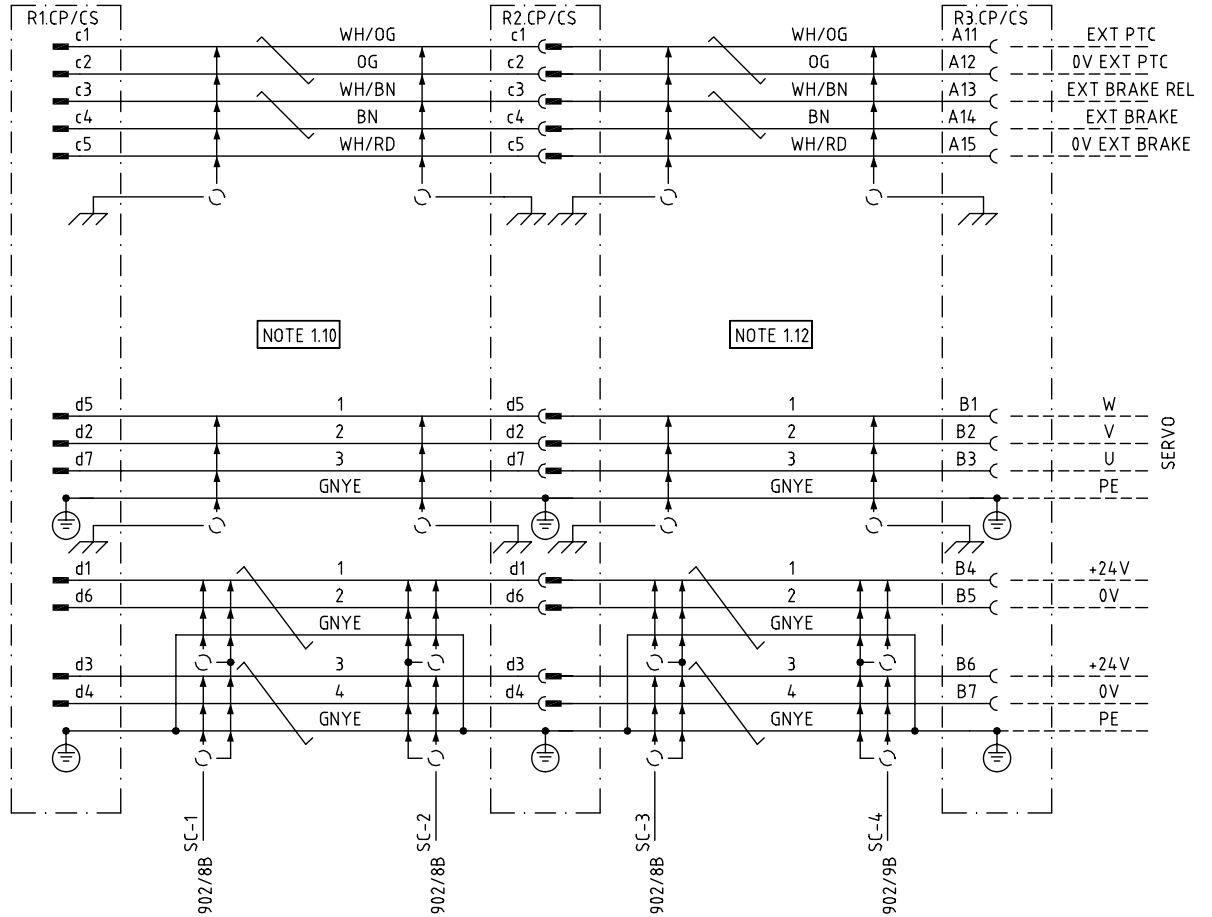

Prepared by, date C Blanksvärd, 050316	Responsible department ATMA/R0/AB	Description ACC	Circuit Diagram
Approved by, date M Thunell, 050406	Take over department	SpotPack for servo gun SpotPack för servotång	Sheet 903
Status Approved			No. of sh. 975
ABB Automation Technologies AB		Document No. 3HAC17669-1	Rev. ind. 03

CABLES AND EXTERNAL CONNECTIONS

IRB 6600/6650/7600

Latest Revision

ABB Automation Technologies AB

3HAC17669-1

03

We reserve all rights in this document and in the information contained therein. Reproduction, use or disclosure to third parties without express authority is strictly forbidden. © Copyright 2003 ABB

TYPE Se
CUSTOMER POWER/
CUSTOMER SIGNALS
PARALLEL
COMMUNICATION

VALID FOR
HARNESS IN CABINET
3HAC020128-001
AND
FLOOR HARNESS
3HAC15910-1

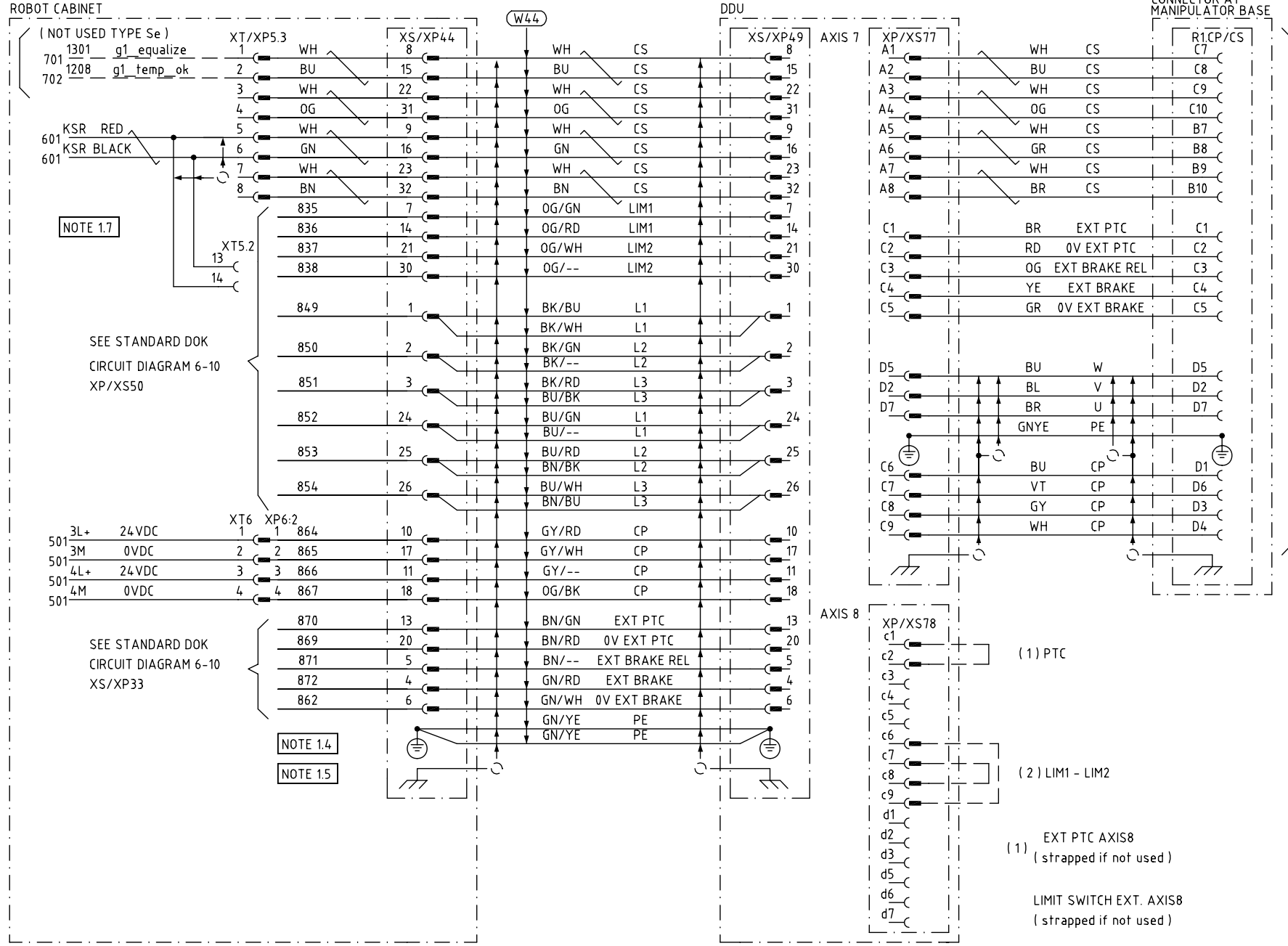

NOTE 1.7

SEE STANDARD DOK
CIRCUIT DIAGRAM 6-10
XP/XS50

SEE STANDARD DOK
CIRCUIT DIAGRAM 6-10
XS/XP33

NOTE 1.4

NOTE 1.5

SEE SIDE 902, 903

B

C

Prepared by, date C Blanksvård, 050316	Responsible department ATMA/RO/AB	Description ACC	Circuit Diagram
Approved by, date M Thunell, 050406	Take over department	SpotPack for servo gun SpotPack för servotång	Sheet 904
Status Approved			No. of sh. 975
ABB Automation Technologies AB		Document No. 3HAC17669-1	Rev. ind. 03

CABLES AND EXTERNAL CONNECTIONS
IRB 6600/6650/7600

Latest Revision

We reserve all rights in this document and in the information contained therein. Reproduction, use or disclosure to third parties without express authority is strictly forbidden. © Copyright 2005 ABB

A

B

C

D

TYPE HSe
CUSTOMER SIGNALS
PARALLEL
COMMUNICATION

VALID FOR
HARDNESS IN CABINET
3HAC17209-1
AND
FLOOR HARNESS
3HAC17147-1,-2,-3,-6
LOWER ARM HARNESS
3HAC020126-001
3HAC020304-001
3HAC020447-001
UPPER ARM HARNESS
3HAC16647-1,-2,-3,-4,-5

NOTE 1.6

RESOLVER SIGNALS TO
PEDESTAL GUN 1
SEE SHEET 908

CONNECTOR AT
MANIPULATOR BASE

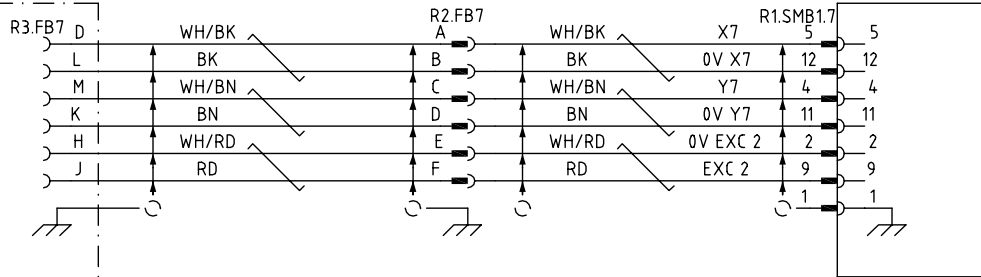

NOTE 1.13

CONNECTOR AT
AXIS 3

NOTE 1.11

CONNECTOR AT
AXIS 6

ROBOT CABINET

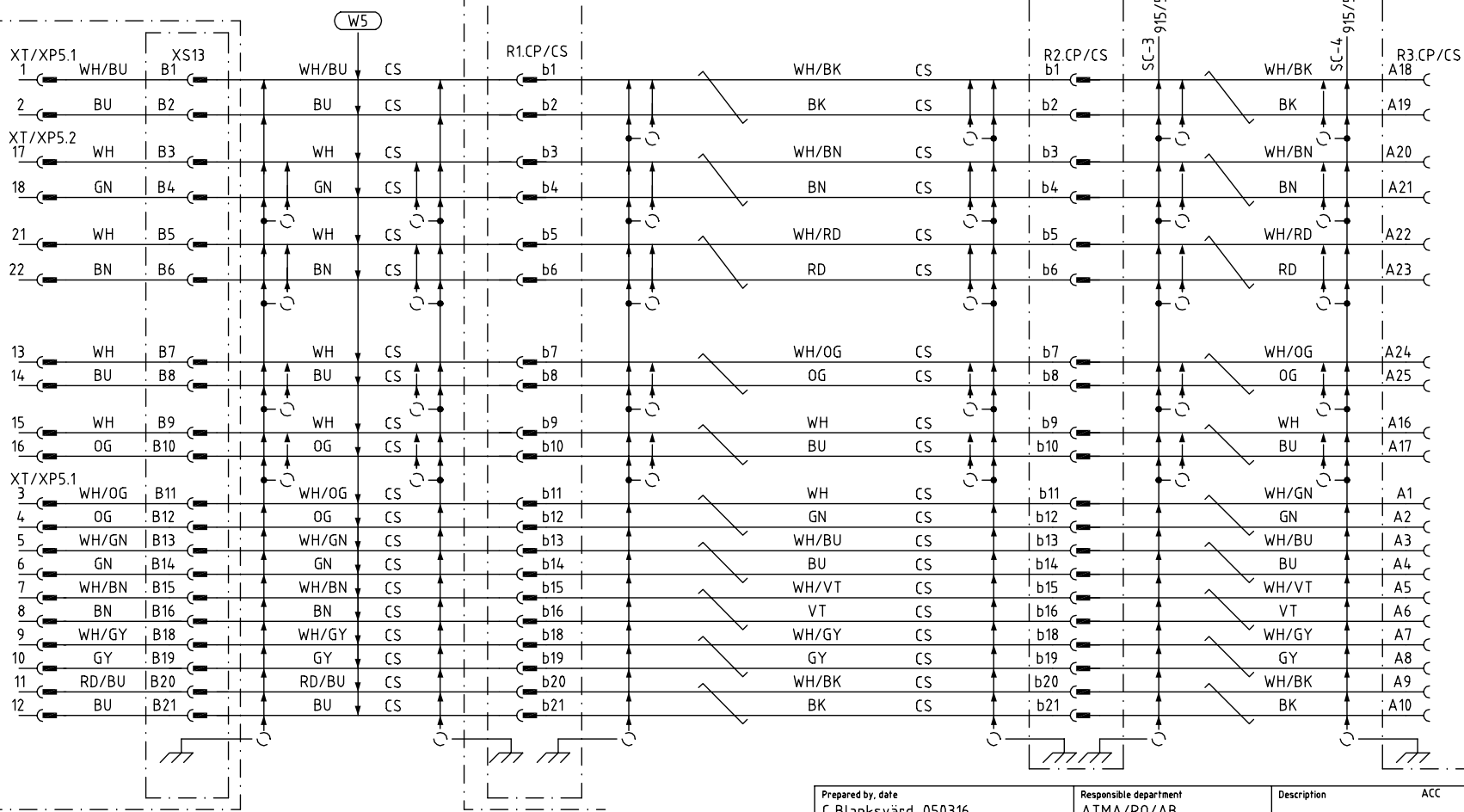

Prepared by, date C Blanksvård, 050316	Responsible department ATMA/RO/AB	Description ACC	Circuit Diagram
Approved by, date M Thunell, 050406	Take over department	SpotPack for servo gun SpotPack för servotång	Sheet 905
Status Approved			No. of sh. 975
ABB ABB Automation Technologies AB		Document No. 3HAC17669-1	Rev. ind. 03

CABLES AND EXTERNAL CONNECTIONS
IRB 6600/6650/7600

Latest Revision

3HAC17669-1

03

We reserve all rights in this document and in the information contained therein. Reproduction, use or disclosure to third parties without express authority is strictly forbidden. © Copyright 2005 ABB

We reserve all rights in this document and in the information contained therein. Reproduction, use or disclosure to third parties without express authority is strictly forbidden. © Copyright 2005 ABB

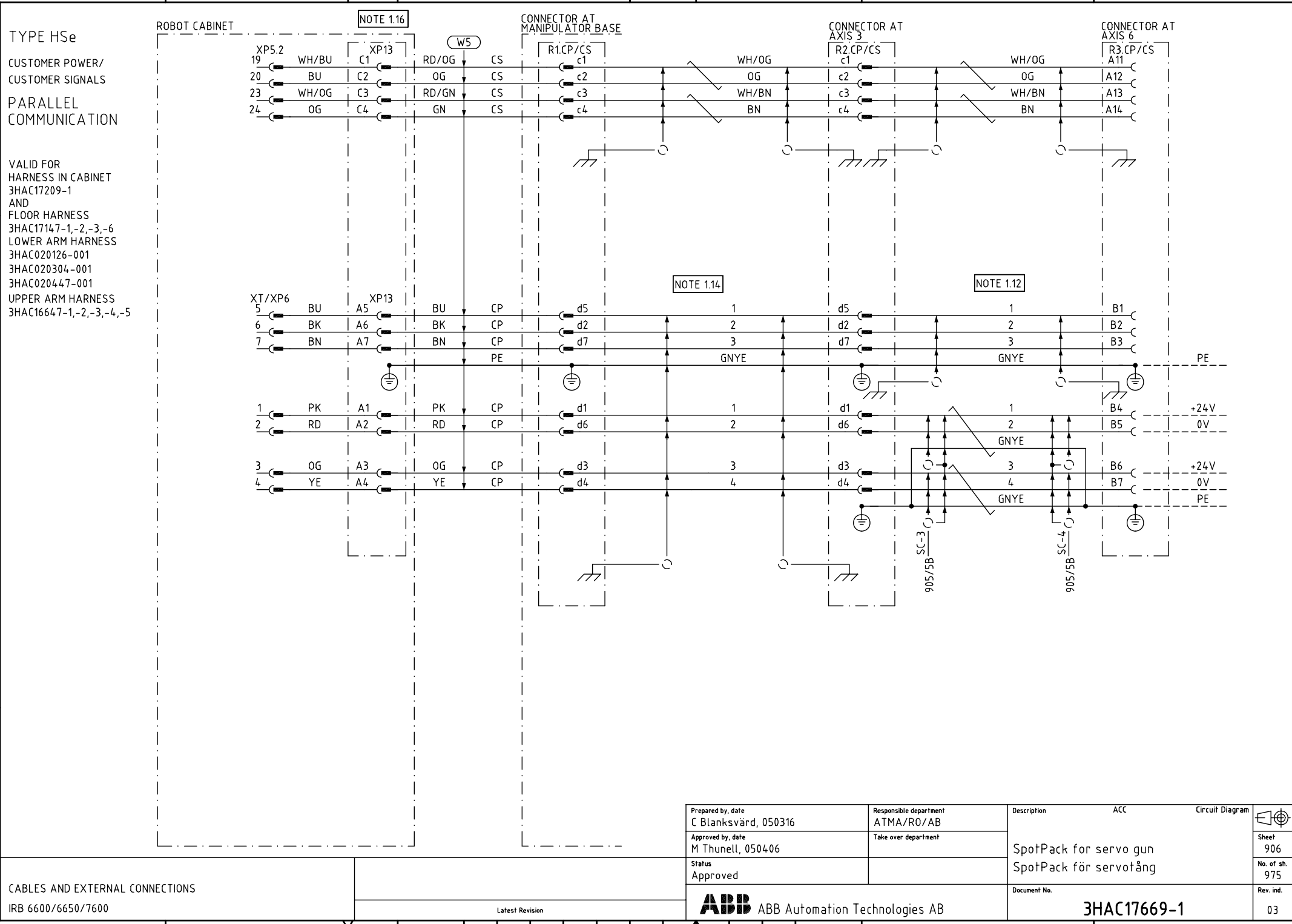

TYPE HSe
 CUSTOMER POWER/
 CUSTOMER SIGNALS
 PARALLEL
 COMMUNICATION

VALID FOR
 HARNESS IN CABINET
 3HAC17209-1
 AND
 FLOOR HARNESS
 3HAC17147-1,-2,-3,-6
 LOWER ARM HARNESS
 3HAC020126-001
 3HAC020304-001
 3HAC020447-001
 UPPER ARM HARNESS
 3HAC16647-1,-2,-3,-4,-5

CABLES AND EXTERNAL CONNECTIONS
 IRB 6600/6650/7600

Prepared by, date C Blanksvård, 050316	Responsible department ATMA/R0/AB	Description ACC SpotPack for servo gun SpotPack för servotång	Circuit Diagram
Approved by, date M Thunell, 050406	Take over department		
Status Approved		Document No. 3HAC17669-1	Sheet 906 No. of sh. 975 Rev. ind. 03

Latest Revision

ABB ABB Automation Technologies AB

TYPE HSe

CUSTOMER POWER/
CUSTOMER SIGNALS
PARALLEL
COMMUNICATION

VALID FOR
HARNESS IN CABINET
3HAC020128-001
AND
FLOOR HARNESS
3HAC15910-1

ROBOT CABINET

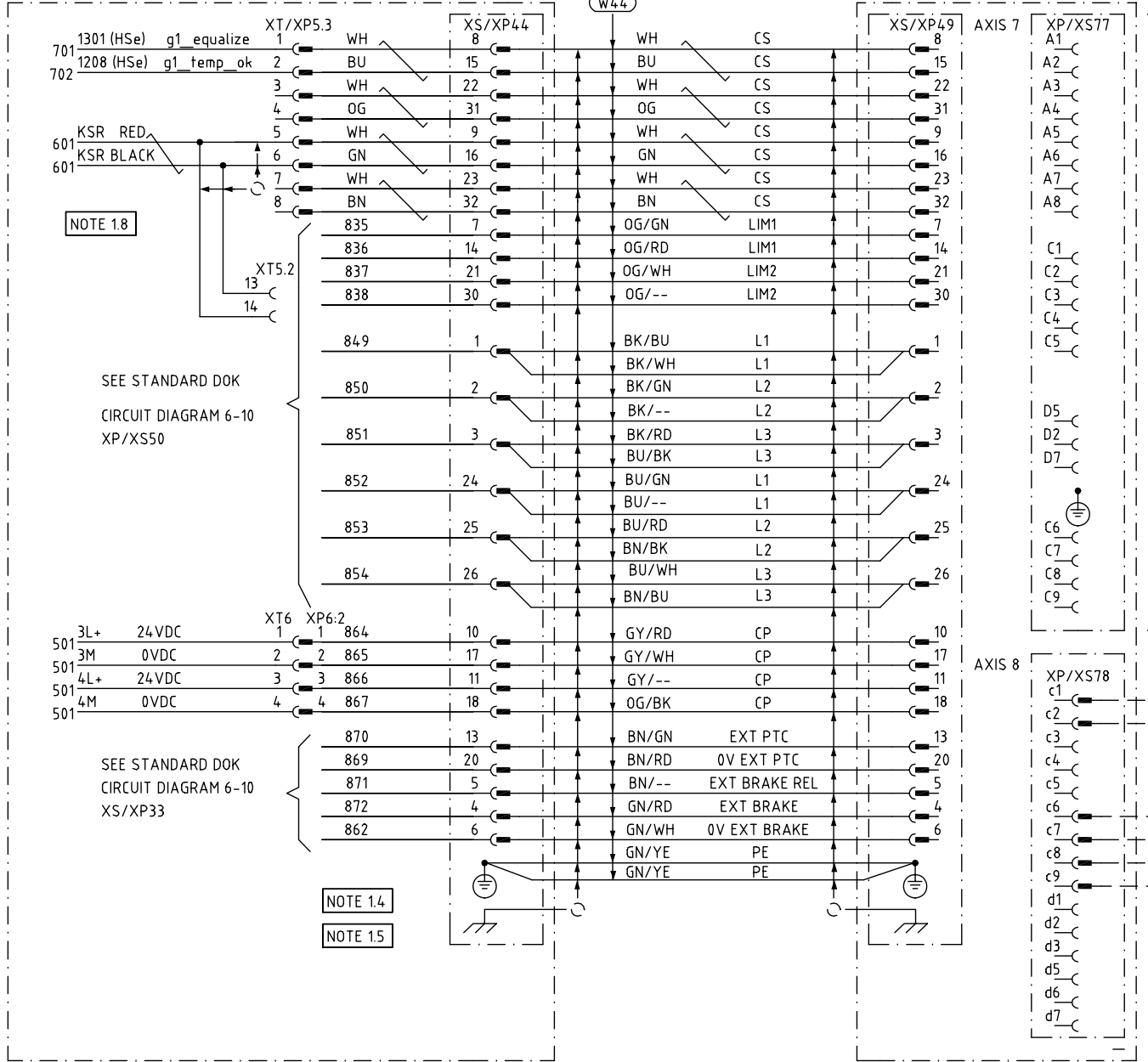

NOTE 1.8

SEE STANDARD DOK
CIRCUIT DIAGRAM 6-10
XP/XP50

SEE STANDARD DOK
CIRCUIT DIAGRAM 6-10
XS/XP33

NOTE 1.4

NOTE 1.5

SERVO DRIVE AND SIGNALS
TO PEDESTAL GUN 1
SEE SHEET 908

(1) PTC

(2) LIM1 - LIM2

(1) EXT PTC AXIS8
(strapped if not used)

(2) LIMIT SWITCH EXT. AXIS8
(strapped if not used)

CABLES AND EXTERNAL CONNECTIONS
IRB 6600/6650/7600

Latest Revision

Prepared by, date C Blanksvård, 050316	Responsible department ATMA/RO/AB	Description ACC	Circuit Diagram
Approved by, date M Thunell, 050406	Take over department	SpotPack for servo gun SpotPack för servotång	Sheet 907
Status Approved			No. of sh. 975
ABB Automation Technologies AB		Document No. 3HAC17669-1	Rev. ind. 03

We reserve all rights in this document and in the information contained therein. Reproduction, use or disclosure to third parties without express authority is strictly forbidden. © Copyright 2005 ABB

TYPE HSe
CUSTOMER SIGNALS
BASIC PARALLEL
COMMUNICATION

VALID FOR
HARNESS IN CABINET
3HAC17209-1
AND
FLOOR HARNESS
3HAC17147-1, -2, -3, -6
LOWER ARM HARNESS
3HAC020303-001
3HAC020179-001
3HAC020447-001
UPPER ARM HARNESS
3HAC16647-1, -2, -3, -4, -5

RESOLVER SIGNALS TO
PEDESTAL GUN 1
SEE SHEET 908

CONNECTOR AT
MANIPULATOR BASE

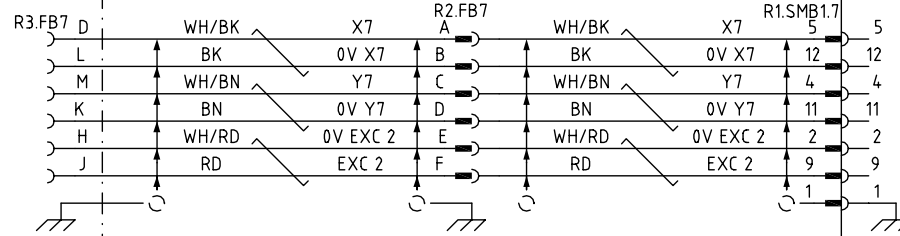

ROBOT CABINET

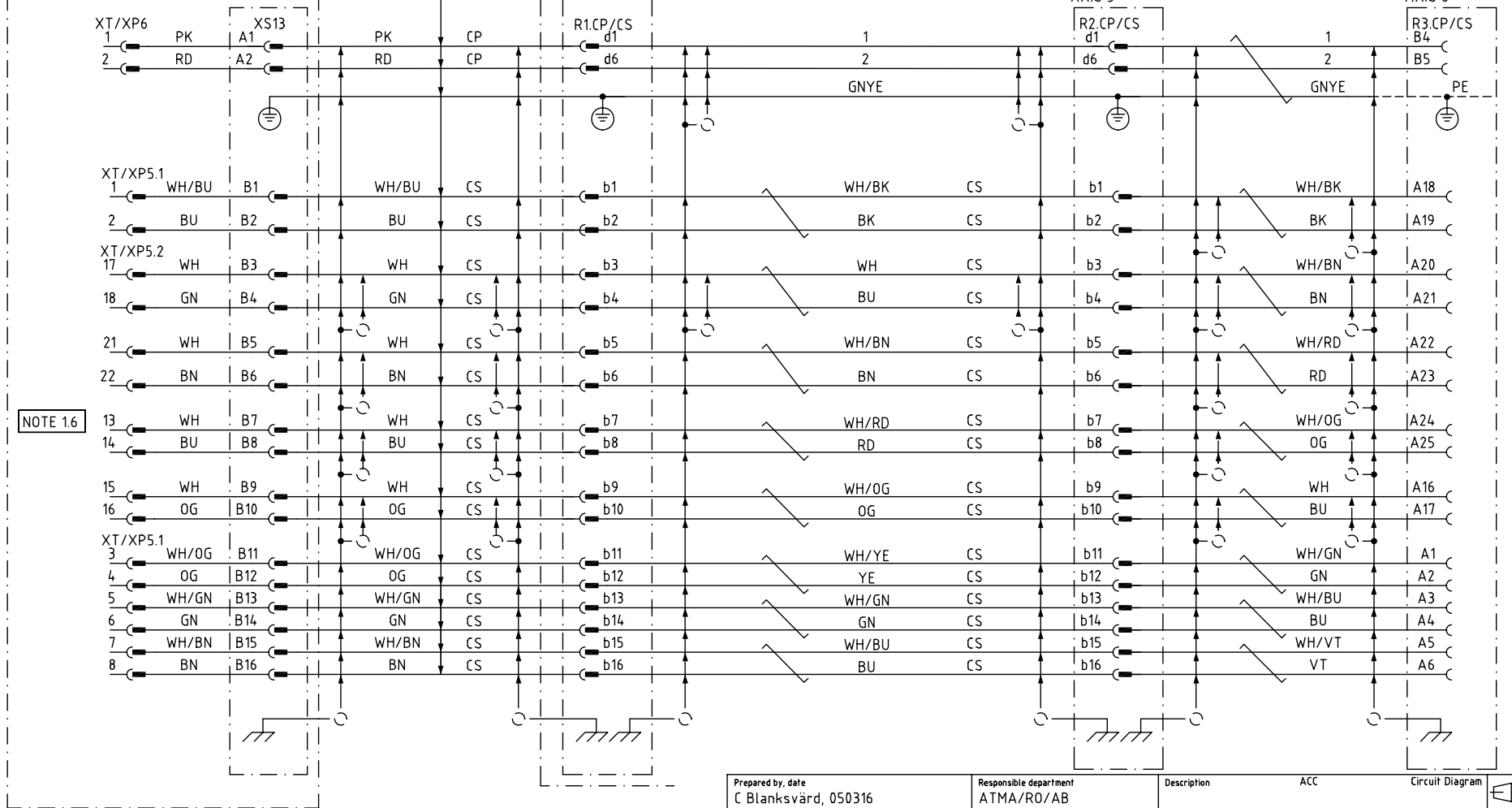

NOTE 1.6

Prepared by, date C Blanksvård, 050316	Responsible department ATMA/RO/AB	Description ACC	Circuit Diagram
Approved by, date M Thunell, 050406	Take over department	SpotPack for servo gun SpotPack för servotång	Sheet 908
Status Approved			No. of sh. 975
ABB Automation Technologies AB		Document No. 3HAC17669-1	Rev. ind. 03

CABLES AND EXTERNAL CONNECTIONS
IRB 6600/6650/7600

Latest Revision

We reserve all rights in this document and in the information contained therein. Reproduction, use or disclosure to third parties without express authority is strictly forbidden. © Copyright 2003 ABB

TYPE HSe

CUSTOMER POWER/
CUSTOMER SIGNALS
PEDESTAL GUN 1

PARALLEL
COMMUNICATION
VALID FOR
FLOOR HARNESS
XP77-R1.CP/CS
3HAC15386-1,-4,-5,-6
AND
R3.FB7-FB.M7
3HAC16425-1

CONNECTOR AT
DDU
SEE SIDE 907

PEDESTAL GUN 1

SERVO DRIVE AND SIGNALS TO PEDESTAL GUN 1

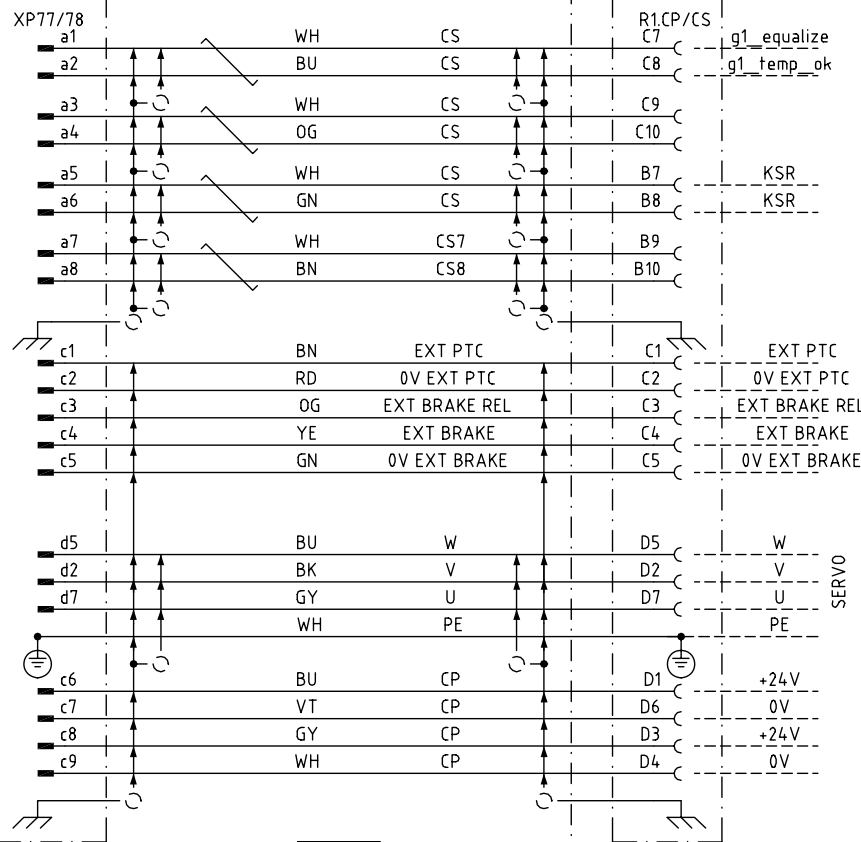

NOTE 1.18

CONNECTOR AT
MANIPULATOR BASE

RESOLVER SIGNALS TO PEDESTAL GUN 1

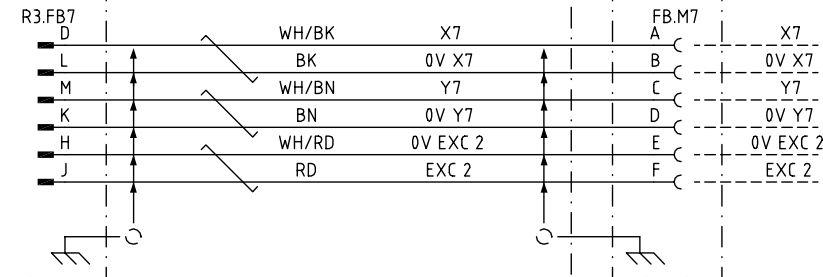

CONNECTION IF PARALLEL
COMMUNICATION USED TO ROBOT GRIPPER
SEE SHEET 905

CONNECTION IF BUS
USED TO ROBOT GRIPPER
SEE SHEET 909 FOR CANBUS
SEE SHEET 910 FOR PROFIBUS
SEE SHEET 911 FOR INTERBUS

CABLES AND EXTERNAL CONNECTIONS
IRB 6600/6650/7600

Latest Revision

Prepared by, date C Blanksvård, 050316	Responsible department ATMA/RO/AB	Description ACC SpotPack for servo gun SpotPack för servotång	Circuit Diagram
Approved by, date M Thunell, 050406	Take over department		
Status Approved		Document No. 3HAC17669-1	No. of sh. 953 Rev. ind. 03

ABB ABB Automation Technologies AB

TYPE HSe
 CUSTOMER POWER/
 CUSTOMER BUS
 CANBUS
 COMMUNICATION

VALID FOR
 HARNESS IN CABINET
 3HAC16904-1
 AND
 FLOOR HARNESS
 3HAC14890-1,-4,-6,-7
 LOWER ARM HARNESS
 3HAC020126-001
 3HAC020304-001
 3HAC020447-001
 UPPER ARM HARNESS
 3HAC16648-1,-2,-3,-4,-5

CABLE W109
 CANBUS SIGNALS TO
 MASTER / SLAVE UNIT
 IN ROBOT CABINET
 A82 SOCKET X6
 SEE STANDARD DOC
 3HAC5582-2

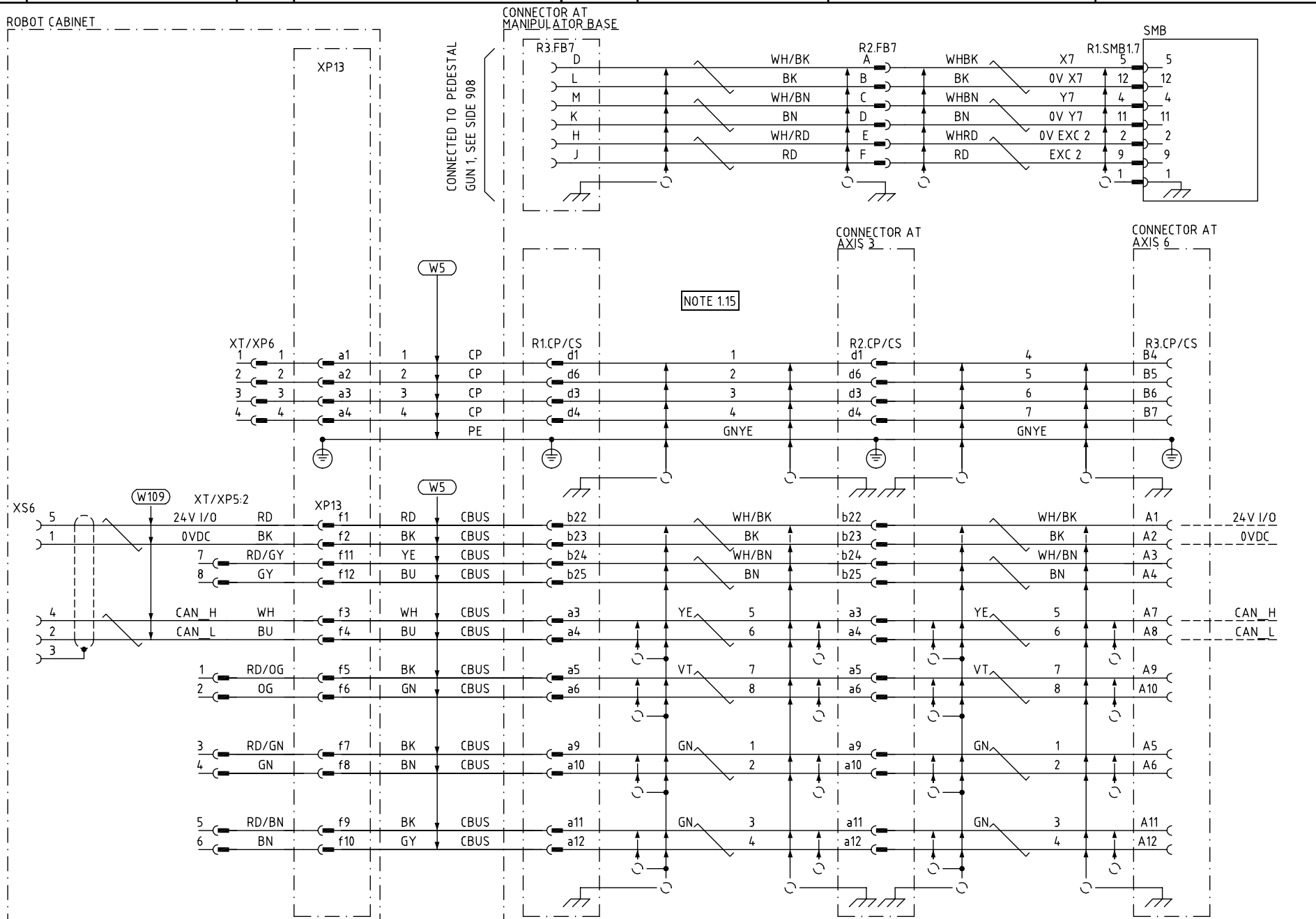

NOTE 1.15

Prepared by, date C Blanksvård, 050316	Responsible department ATMA/RO/AB	Description ACC SpotPack for servo gun SpotPack för servotång	Circuit Diagram
Approved by, date M Thunell, 050406	Take over department		
Status Approved		Document No. 3HAC17669-1	Sheet 910 No. of sh. 975 Rev. ind. 03

CABLES AND EXTERNAL CONNECTIONS
 IRB 6600/6650/7600

Latest Revision

ABB ABB Automation Technologies AB

3HAC17669-1

03

TYPE HSe
 CUSTOMER POWER/
 CUSTOMER BUS
 PROFIBUS
 COMMUNICATION

VALID FOR
 HARNESS IN CABINET
 3HAC17189-1
 AND
 FLOOR HARNESS
 3HAC17200-1,-4,-5,-6
 LOWER ARM HARNESS
 3HAC020126-001
 3HAC020304-001
 3HAC020447-001
 UPPER ARM HARNESS
 3HAC16648-1,-2,-3,-4,-5

CABLE W109
 PROFIBUS SIGNALS TO
 MASTER / SLAVE UNIT
 IN ROBOT CABINET
 D-SUB SOCKET X8
 SEE STANDARD DOC
 3HAC5582-2

ROBOT CABINET

CONNECTOR AT
 MANIPULATOR BASE

CONNECTED TO PEDESTAL
 GUN 1, SEE SIDE 908

CONNECTOR AT
 AXIS 3

CONNECTOR AT
 AXIS 6

SMB

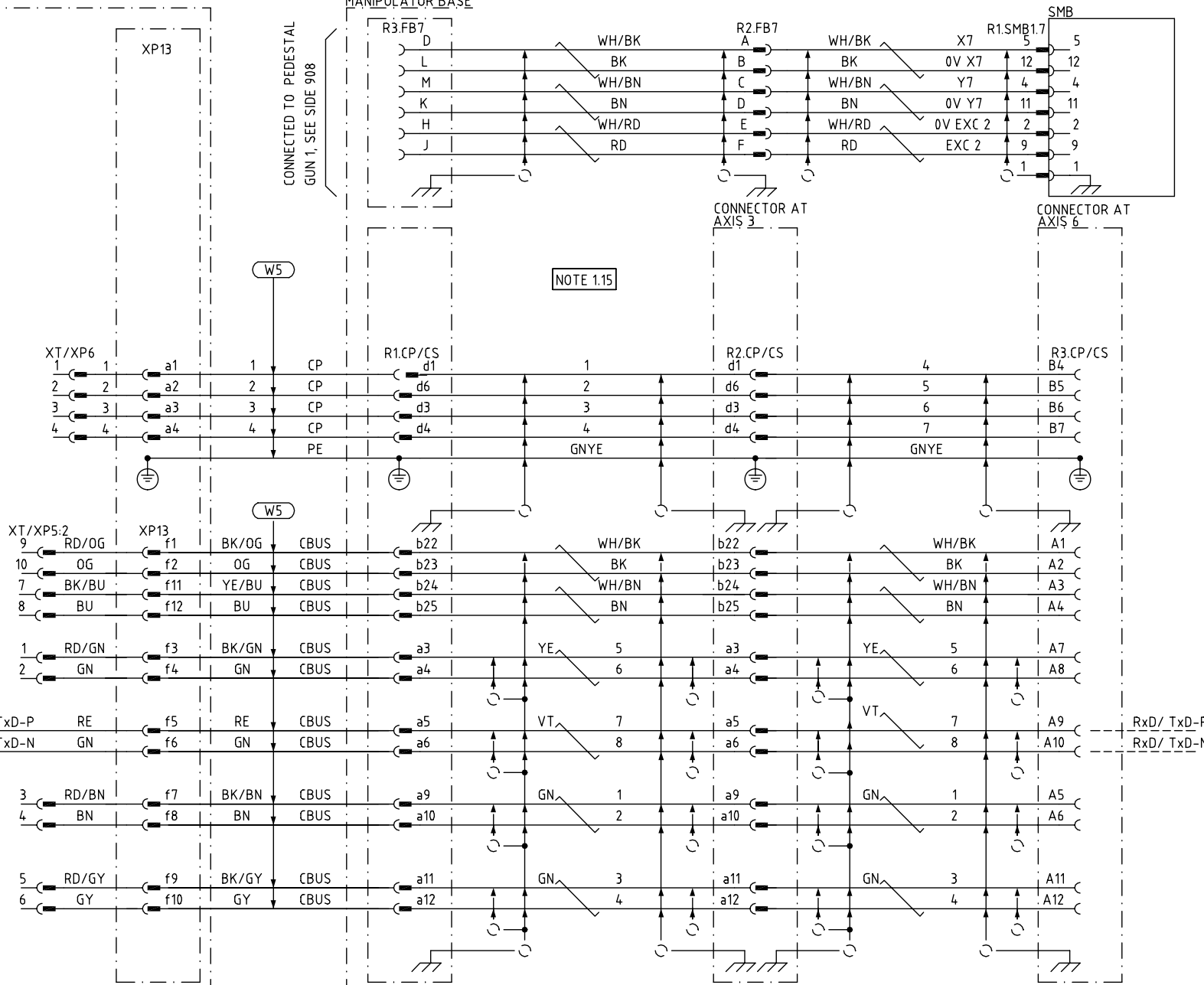

NOTE 1.15

Prepared by, date C Blanksvård, 050316	Responsible department ATMA/RO/AB	Description ACC SpotPack for servo gun SpotPack för servotång	Circuit Diagram
Approved by, date M Thunell, 050406	Take over department		
Status Approved		Document No. 3HAC17669-1	Sheet 911 No. of sh. 975 Rev. ind. 03

CABLES AND EXTERNAL CONNECTIONS
 IRB 6600/6650/7600

Latest Revision

ABB ABB Automation Technologies AB

TYPE HSe
CUSTOMER POWER/
CUSTOMER BUS

INTERBUS
COMMUNICATION

VALID FOR
HARNESS IN CABINET
3HAC16905-1
AND
FLOOR HARNESS
3HAC15644-1,-4,-5,-6
LOWER ARM HARNESS
3HAC020126-001
3HAC020304-001
3HAC020447-001
UPPER ARM HARNESS
3HAC16648-1,-2,-3,-4,-5

ROBOT CABINET

MANIPULATOR BASE

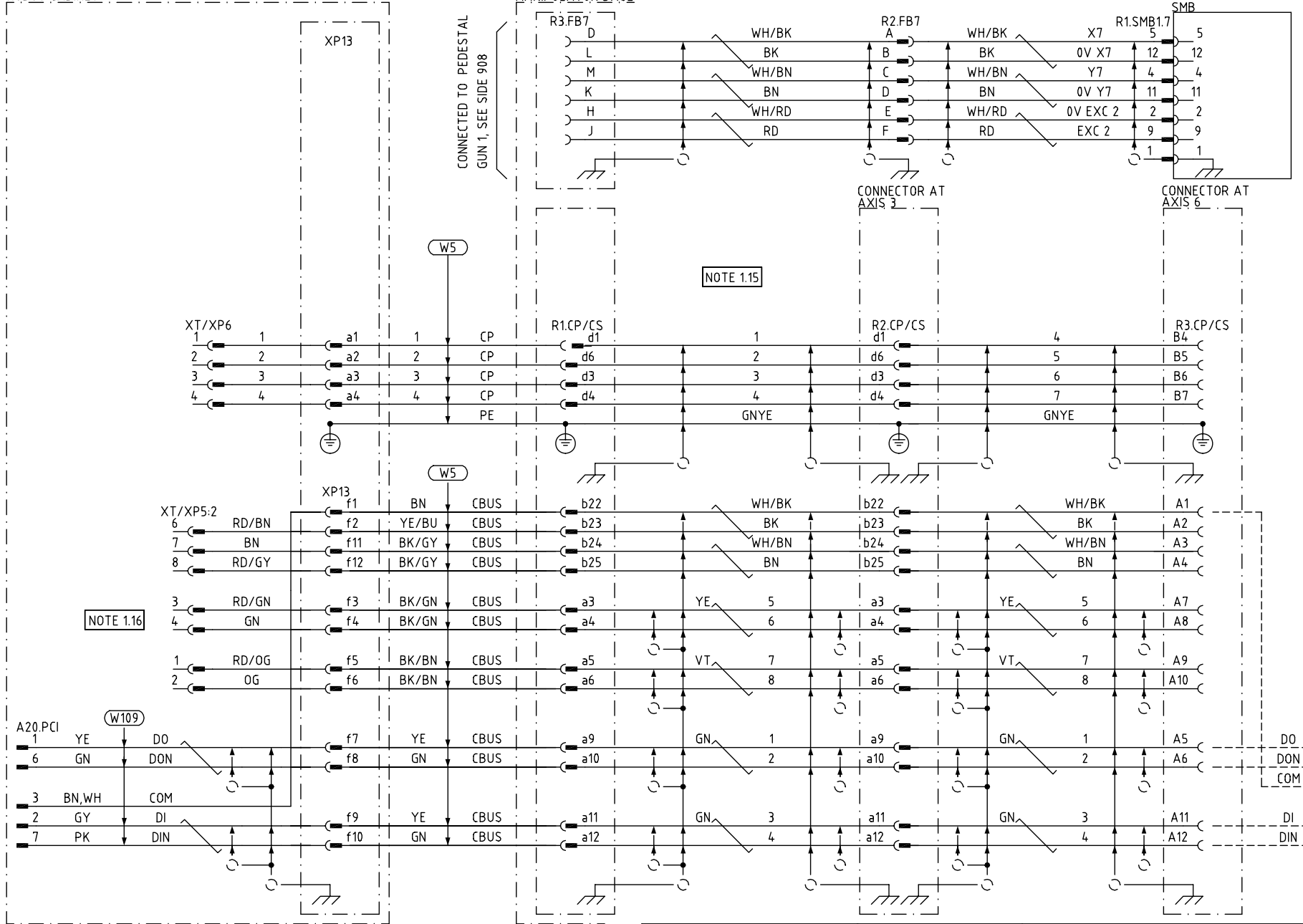

NOTE 1.16

NOTE 1.15

A20.PCI
CABLE W109
INTERBUS SIGNALS TO
MASTER UNIT
IN ROBOT CABINET
A20.PCI
SEE STANDARD DOC
3HAC 5582-2

CABLES AND EXTERNAL CONNECTIONS
IRB 6600/6650/7600

Prepared by, date C Blanksvård, 050316	Responsible department ATMA/RO/AB	Description ACC SpotPack for servo gun SpotPack för servotång	Circuit Diagram
Approved by, date M Thunell, 050406	Take over department		
Status Approved		Document No. 3HAC17669-1	No. of sh. 912 975 Rev. ind. 03

Latest Revision

ABB ABB Automation Technologies AB

TYPE Se / HSe

CUSTOMER POWER

FAN UNIT

POWER UNIT CABINET

OPTION 464-1
COOLING FAN FOR INVERTER OR THYRISTOR

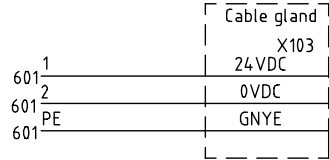

POWER UNIT CABINET

FU100 FAN UNIT

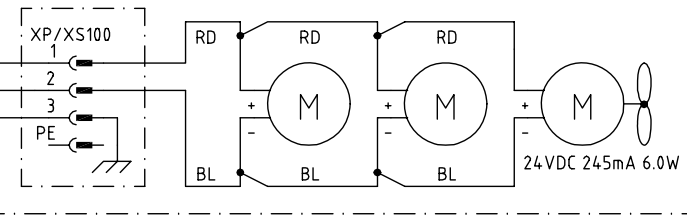

We reserve all rights in this document and in the information contained therein. Reproduction, use or disclosure to third parties without express authority is strictly forbidden. © Copyright 2003 ABB

CABLES AND EXTERNAL CONNECTIONS

IRB 6600/6650/7600

Latest Revision

Prepared by, date C Blanksvärd, 050318	Responsible department ATMA/RO/AB	Description ACC SpotPack for servo gun SpotPack för servotång	Circuit Diagram
Approved by, date M Thunell, 050406	Take over department		
Status Approved		Document No. 3HAC17669-1	Sheet 913 No. of sh. 975 Rev. ind. 03

ABB ABB Automation Technologies AB

We reserve all rights in this document and in the information contained therein. Reproduction, use or disclosure to third parties without express authority is strictly forbidden. © Copyright 2015 ABB

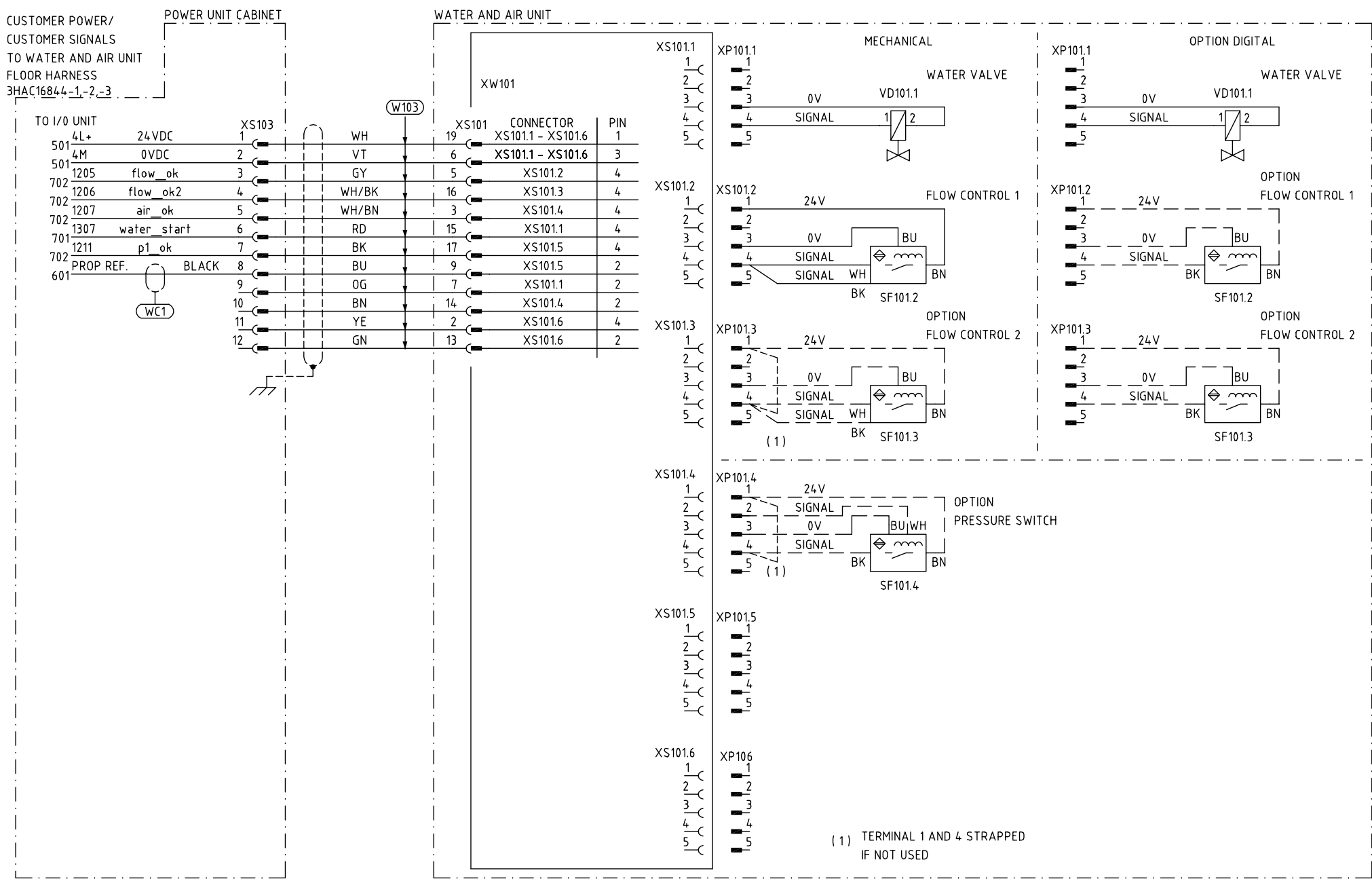

CABLES AND EXTERNAL CONNECTIONS
IRB 6600/6650/7600

Latest Revision

Prepared by, date C Blanksvärd, 050317	Responsible department ATMA/RO/AB	Description ACC	Circuit Diagram
Approved by, date M Thunell, 050406	Take over department	SpotPack for servo gun SpotPack för servotång	Sheet 914
Status Approved			No. of sh. 975
ABB ABB Automation Technologies AB		Document No. 3HAC17669-1	Rev. ind. 03

We reserve all rights in this document and in the information contained therein. Reproduction or distribution to third parties without express authority is strictly forbidden. © Copyright 2019 ABB

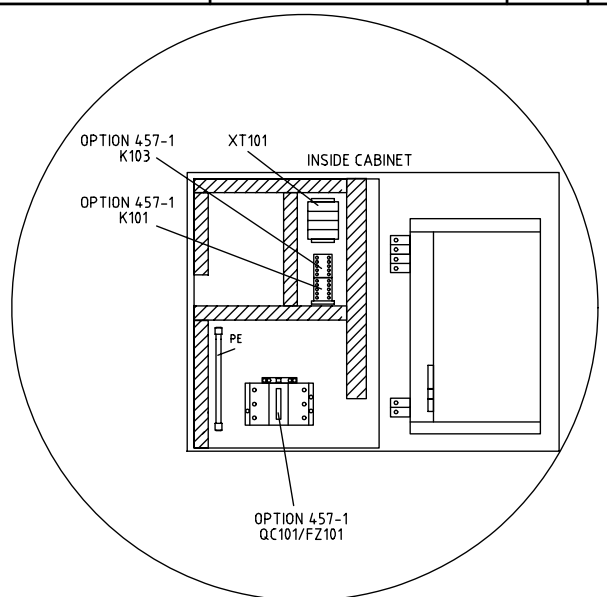

NOTE 1.1 CIRCUIT DIAGRAM: 3HAC17669-1, REV.00

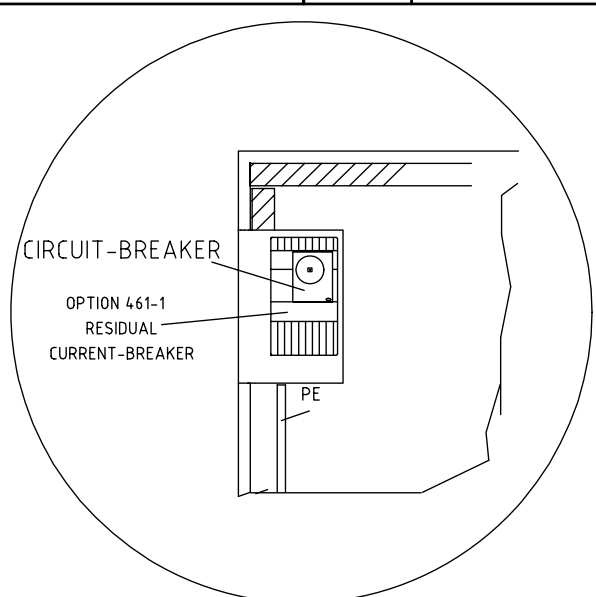

NOTE 1.2 CIRCUIT DIAGRAM: 3HAC17669-1, REV.00

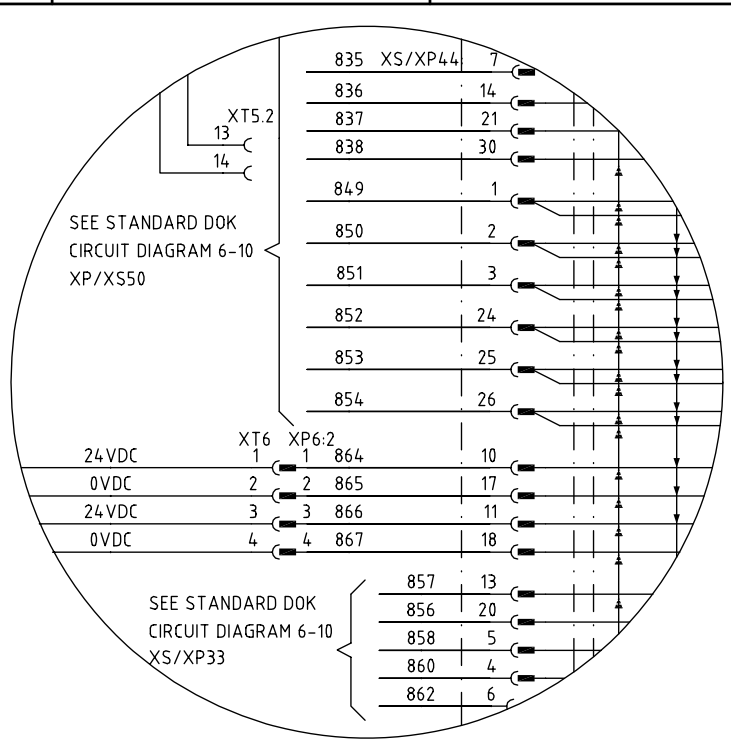

NOTE 1.4 HARNESS IN CABINET
3HAC16093-1, REV.02
PARALLEL COMMUNICATION, Se

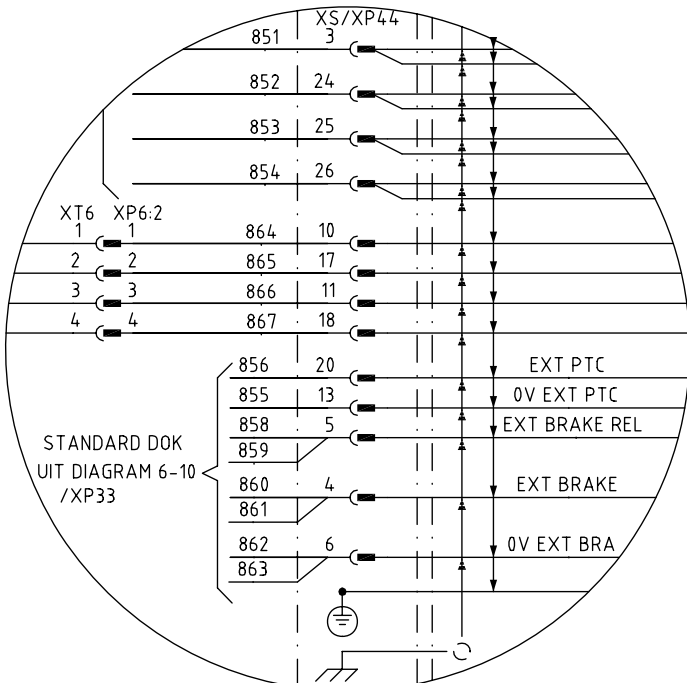

NOTE 1.5 HARNESS IN CABINET
3HAC16093-1, REV.00,01
PARALLEL COMMUNICATION, Se

DESIGN CHANGES, NOTE 1.1-1.2, 1.4-1.5
KOSTRUKTIONSÄNDRINGAR, NOT 1.1-1.2, 1.4-1.5
IRB 6600/6650/7600

Prepared by, date C Blanksvård, 050316	Responsible department ATMA/RO/AB	Description ACC	Circuit Diagram
Approved by, date M Thunell, 050406	Take over department	SpotPack for servo gun SpotPack för servotång	Sheet 950
Status Approved			No. of sh. 975
Document No. 3HAC17669-1			Rev. ind. 03

ABB ABB Automation Technologies AB

Latest Revision

We reserve all rights in this document and in the information contained therein. Reproduction or disclosure to third parties without express authority is strictly forbidden. © Copyright 2012 ABB

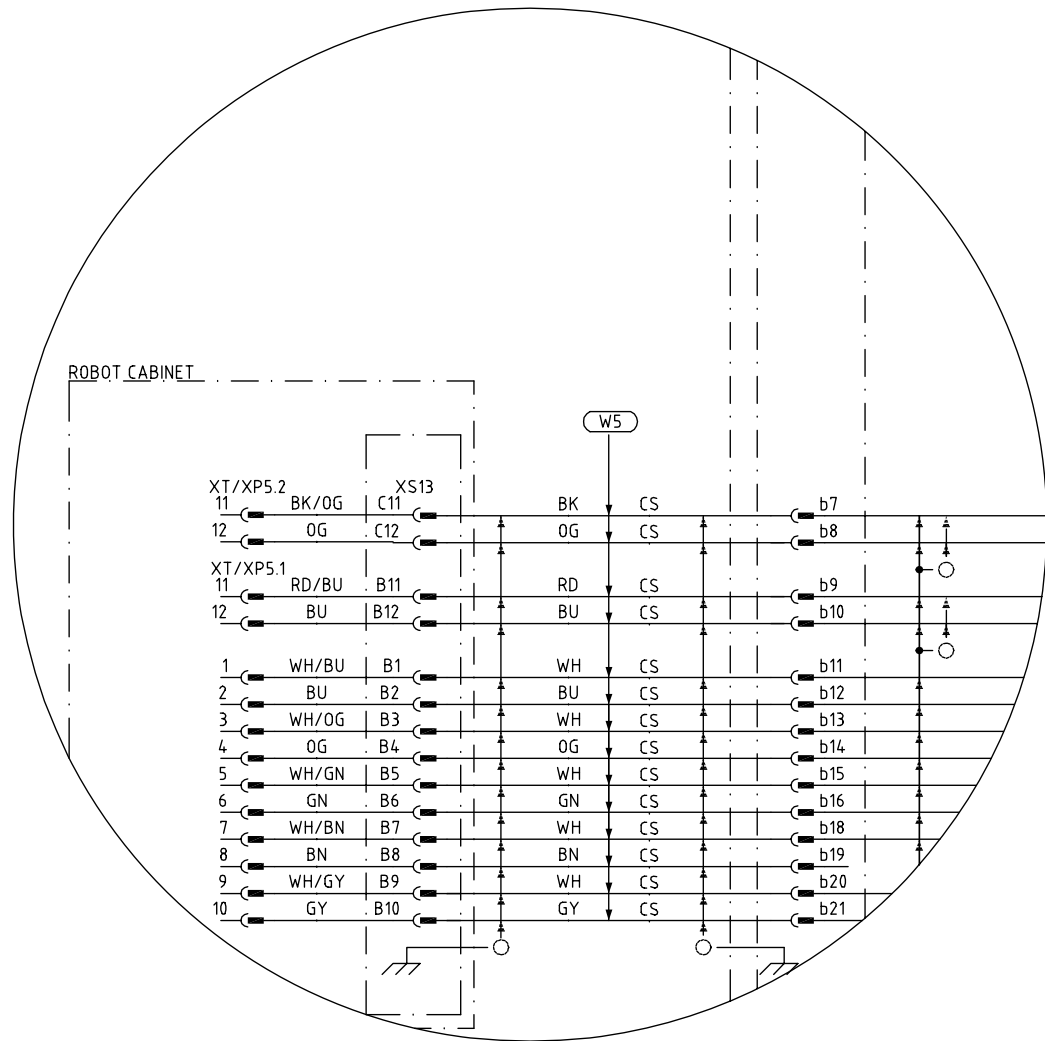

NOTE 1.6

PARALLEL COMMUNICATION, HSe
 HARNESS IN CABINET
 3HAC16333-1
 FLOOR HARNESS
 3HAC14890-1,-4,-6,-7

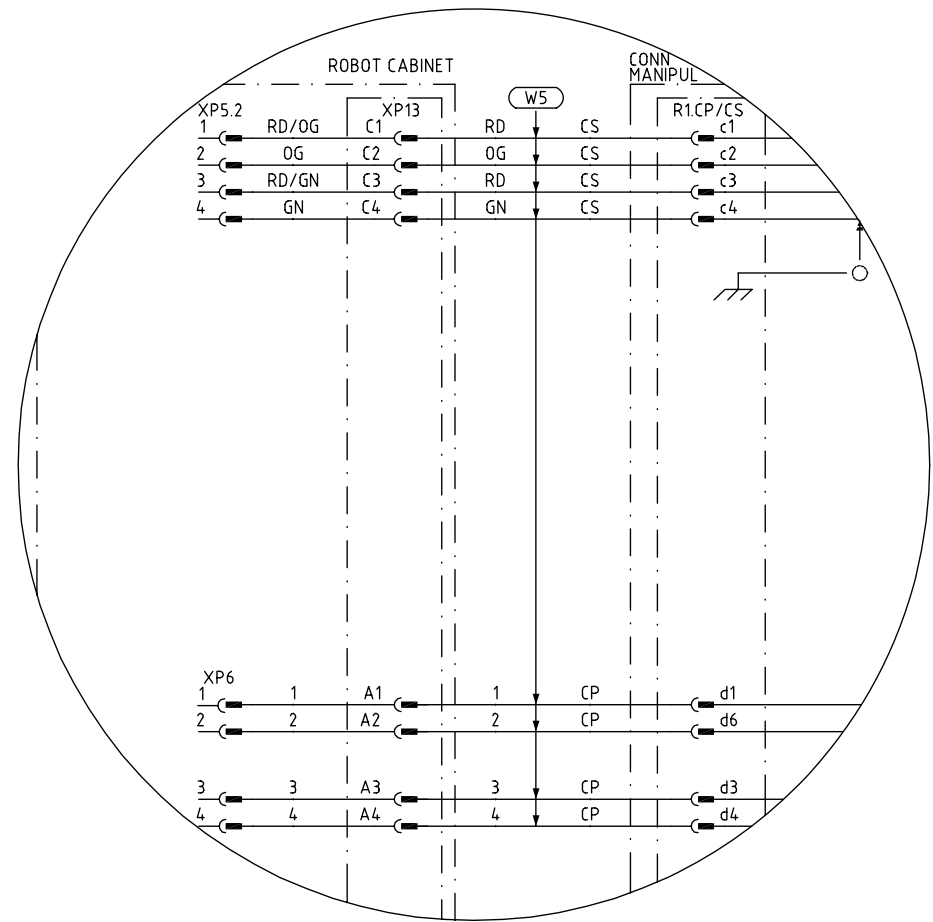

NOTE 1.16

PARALLEL COMMUNICATION, HSe
 HARNESS IN CABINET
 3HAC16333-1
 FLOOR HARNESS
 3HAC14890-1,-4,-6,-7

DESIGN CHANGES, NOTE 1.6,1.16
 KOSTRUKTIONSÄNDRINGAR, NOT 1.6,1.16
 IRB 6600/6650/7600

Latest Revision

Prepared by, date C Blanksvård, 050316	Responsible department ATMA/RO/AB	Description ACC	Circuit Diagram
Approved by, date M Thunell, 050406	Take over department		
Status Approved		SpotPack for servo gun SpotPack för servotång	Sheet 951
			No. of sh. 975
Document No. 3HAC17669-1			Rev. ind. 03

ABB ABB Automation Technologies AB

We reserve all rights in this document and in the information contained therein. Reproduction or disclosure to third parties without express authority is strictly forbidden. © Copyright 2012 ABB

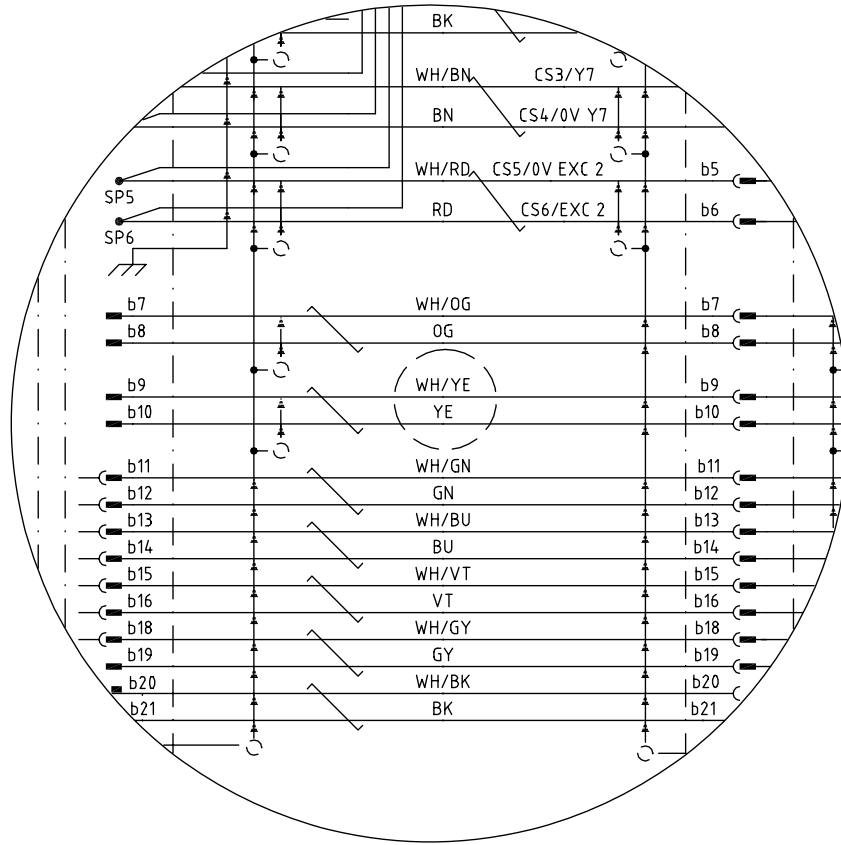

NOTE 1.9

LOWER ARM HARNESS
 PARALLEL COMMUNICATION, Se
 3HAC16782-1, REV.00
 3HAC16783-1, REV.00,01
 3HAC16788-1, REV.00
 3HAC16789-1, REV.00,01
 PARALLEL COMMUNICATION, HSe
 3HAC16794-1, REV.00,01
 3HAC16795-1, REV.00,01

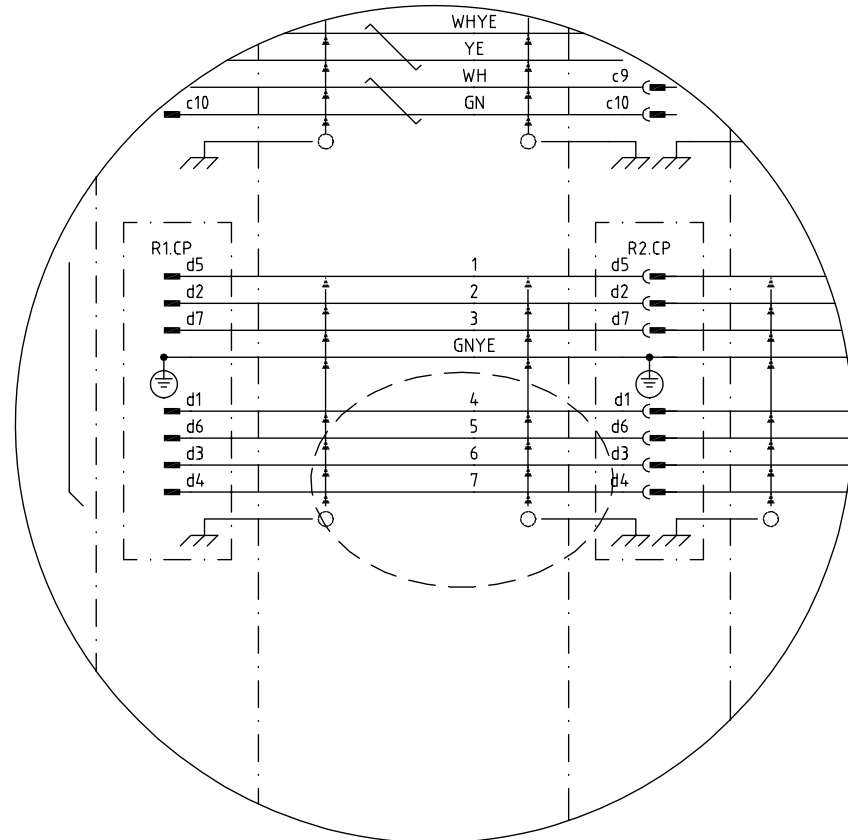

NOTE 1.10

LOWER ARM HARNESS
 PARALLEL COMMUNICATION, Se
 3HAC16782-1, REV.00
 3HAC16783-1, REV.00,01
 3HAC16788-1, REV.00
 3HAC16789-1, REV.00,01
 PARALLEL COMMUNICATION, HSe
 3HAC16794-1, REV.00,01
 3HAC16795-1, REV.00,01

DESIGN CHANGES, NOTE 1.9,1.10
 KOSTRUKTIONSÄNDRINGAR, NOT 1.9,1.10
 IRB 6600/6650/7600

Latest Revision

Prepared by, date C Blanksvärd, 050316	Responsible department ATMA/RO/AB	Description ACC SpotPack for servo gun SpotPack för servotång	Circuit Diagram
Approved by, date M Thunell, 050406	Take over department		
Status Approved		Document No. 3HAC17669-1	Sheet 952 No. of sh. 975 Rev. ind. 03

ABB ABB Automation Technologies AB

We reserve all rights in this document and in the information contained therein. Reproductions or disclosures to third parties without express authority is strictly forbidden. © Copyright 2012 ABB

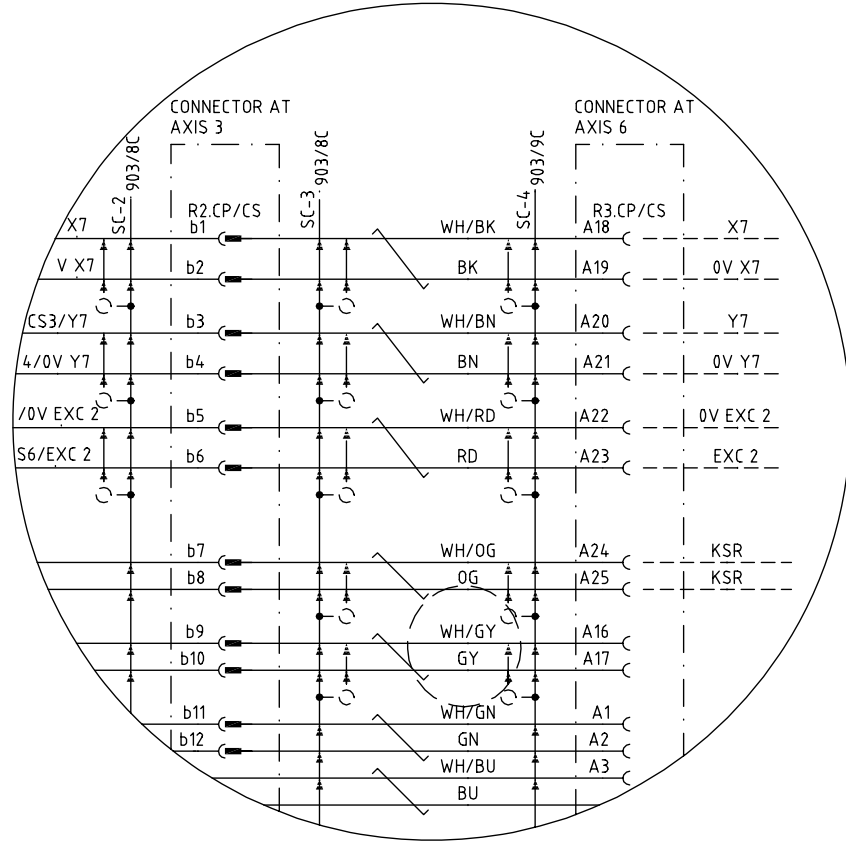

NOTE 1.11

UPPER ARM HARNESS
 PARALLEL COMMUNICATION, Se
 3HAC16643-1,-2,-3, REV.00,01,02
 3HAC16645-1,-2,-3, REV.00,01
 PARALLEL COMMUNICATION, HSe
 3HAC16647-1,-2,-3,-4,-5, REV.00,01

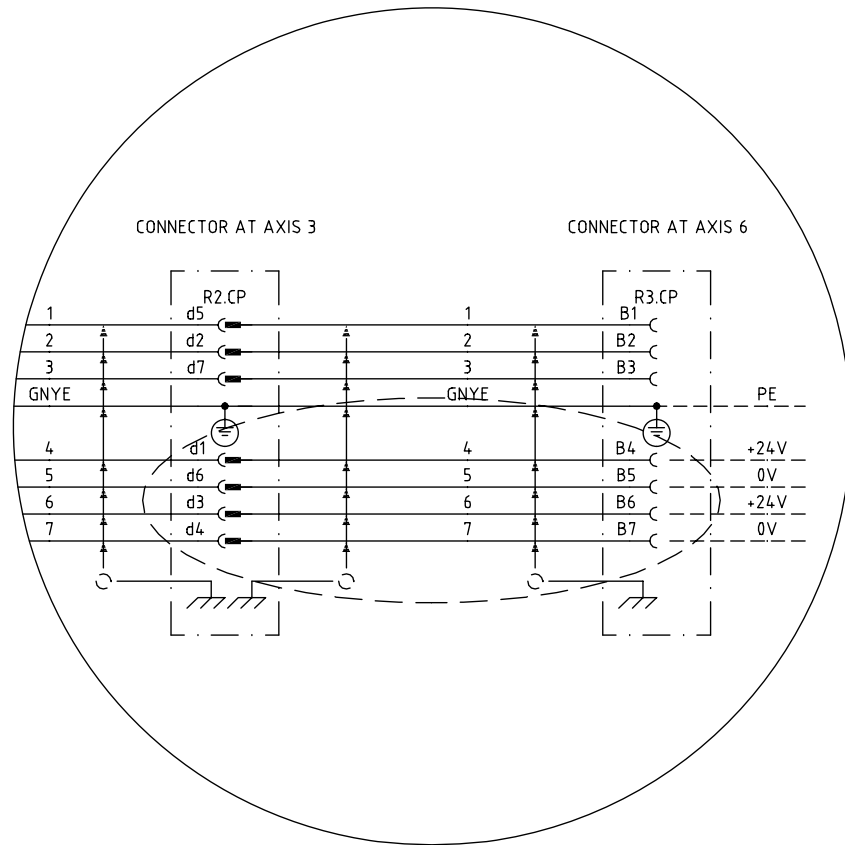

NOTE 1.12

UPPER ARM HARNESS
 PARALLEL COMMUNICATION, Se
 3HAC16643-1,-2,-3, REV.00,01,02
 3HAC16645-1,-2,-3, REV.00,01
 PARALLEL COMMUNICATION, HSe
 3HAC16647-1,-2,-3,-4,-5, REV.00,01

DESIGN CHANGES, NOTE 1.11,1.12
 KOSTRUKTIONSÄNDRINGAR,NOT 1.11,1.12
 IRB 6600/6650/7600

Latest Revision

Prepared by, date C Blanksvärd, 050316	Responsible department ATMA/RO/AB	Description ACC SpotPack for servo gun SpotPack för servotång	Circuit Diagram
Approved by, date M Thunell, 050406	Take over department		
Status Approved		Document No. 3HAC17669-1	Sheet 953 No. of sh. 975 Rev. ind. 03

ABB ABB Automation Technologies AB

We reserve all rights in this document and in the information contained therein. Reproductions or alterations to third parties without express authority is strictly forbidden. © Copyright 2015 ABB

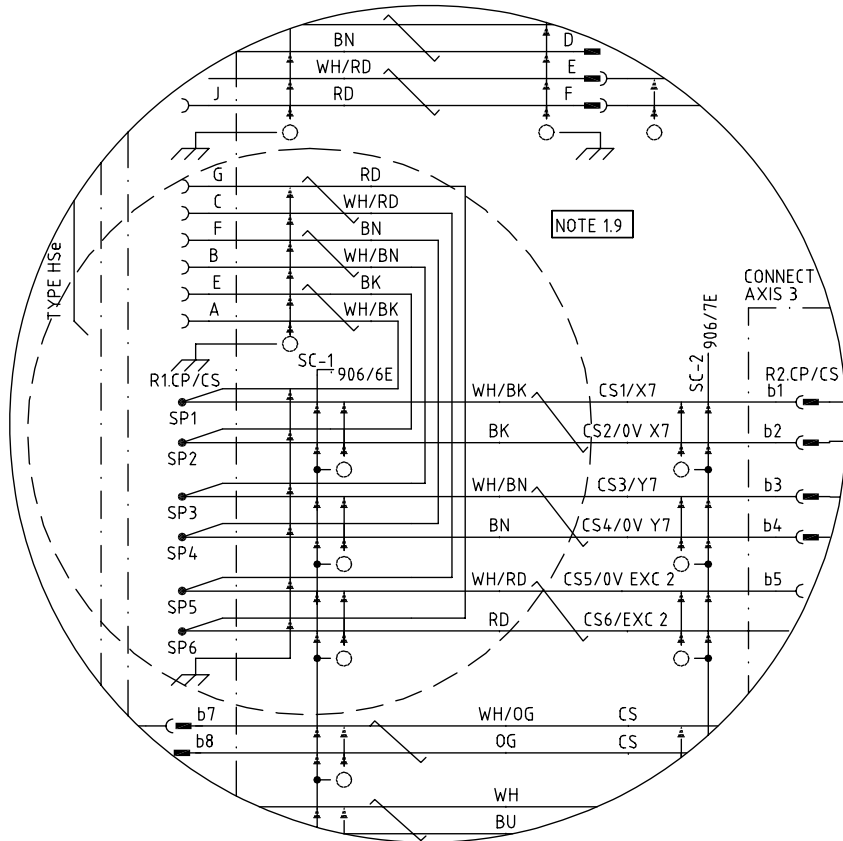

NOTE 1.13
 LOWER ARM HARNESS
 PARALLEL COMMUNICATION, HSe
 3HAC16794-1, REV.02
 3HAC16795-1, REV.02

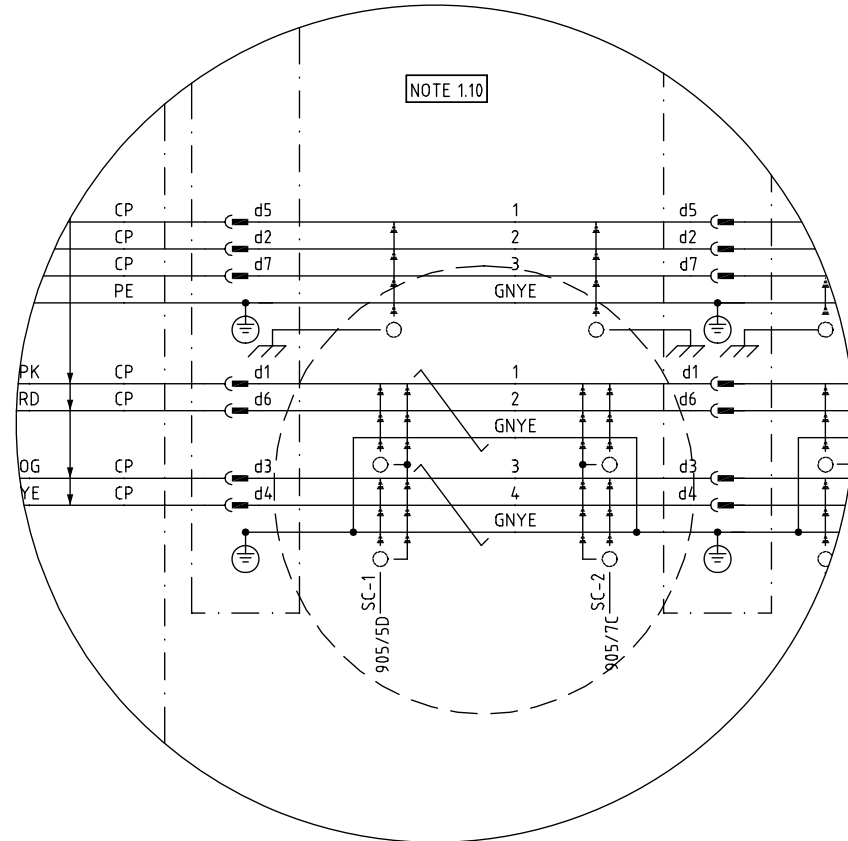

NOTE 1.14
 LOWER ARM HARNESS
 PARALLEL COMMUNICATION, HSe
 3HAC16794-1, REV.02
 3HAC16795-1, REV.02

DESIGN CHANGES, NOTE 1.13, 1.14
 KONSTRUKTIONSÄNDRINGAR, NOT 1.13, 1.14
 IRB 6600/6650/7600

Latest Revision

Prepared by, date C Blanksvärd, 050316	Responsible department ATMA/RO/AB	Description ACC SpotPack for servo gun SpotPack för servotång	Circuit Diagram
Approved by, date M Thunell, 050406	Take over department		
Status Approved		Document No. 3HAC17669-1	No. of sh. 954 Rev. ind. 975 03

ABB Automation Technologies AB

We reserve all rights in this document and in the information contained therein. Reproductions or dissemination to third parties without express authority is strictly forbidden. © Copyright 2019 ABB

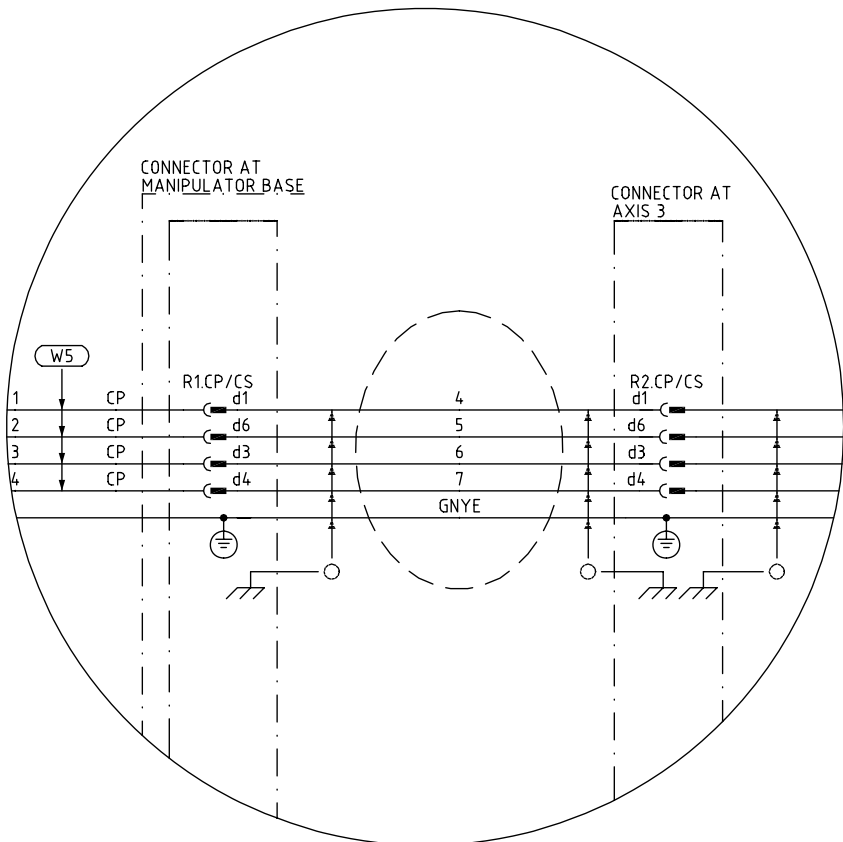

NOTE 1.15
 LOWER ARM HARNESS
 BUS COMMUNICATION, HSe
 3HAC16796-1
 3HAC16797-1

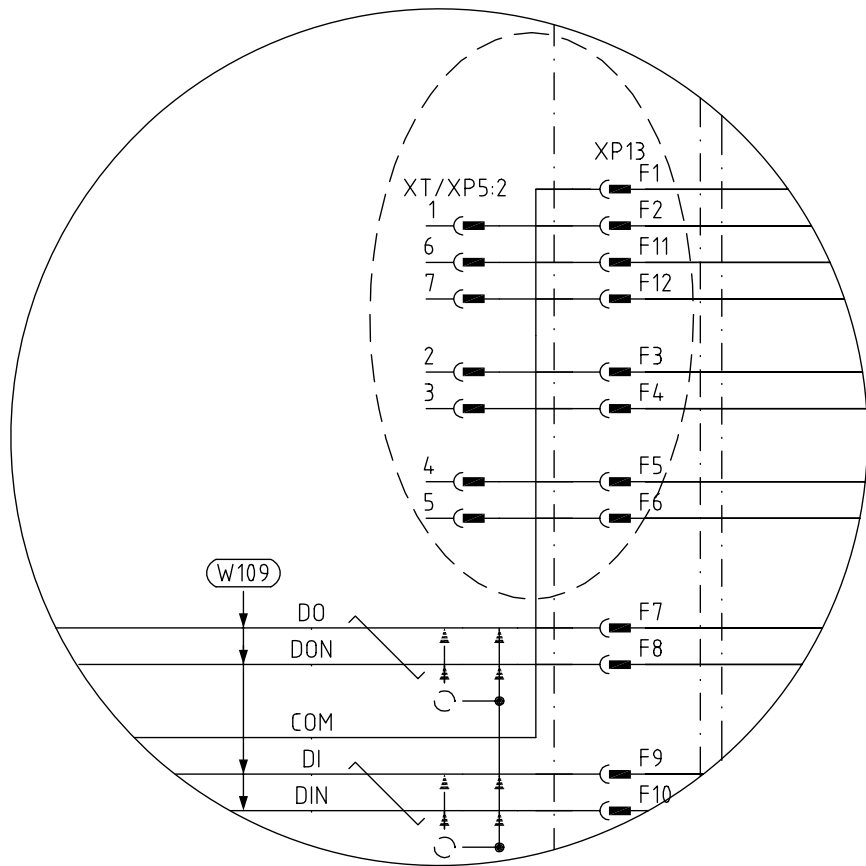

NOTE 1.17
 HARNESS IN CABINET
 INTERBUS COMMUNICATION, HSe
 3HAC16905-1, REV.00

DESIGN CHANGES, NOTE 1.15, 1.17
 KONSTRUKTIONSÄNDRINGAR, NOT 1.15, 1.17
 IRB 6600/6650/7600

Latest Revision

Prepared by, date C Blanksvård, 050316	Responsible department ATMA/RO/AB	Description ACC SpotPack for servo gun SpotPack för servotång	Circuit Diagram
Approved by, date M Thunell, 050406	Take over department		
Status Approved		Document No. 3HAC17669-1	Sheet 955 No. of sh. 975 Rev. ind. 03

ABB Automation Technologies AB

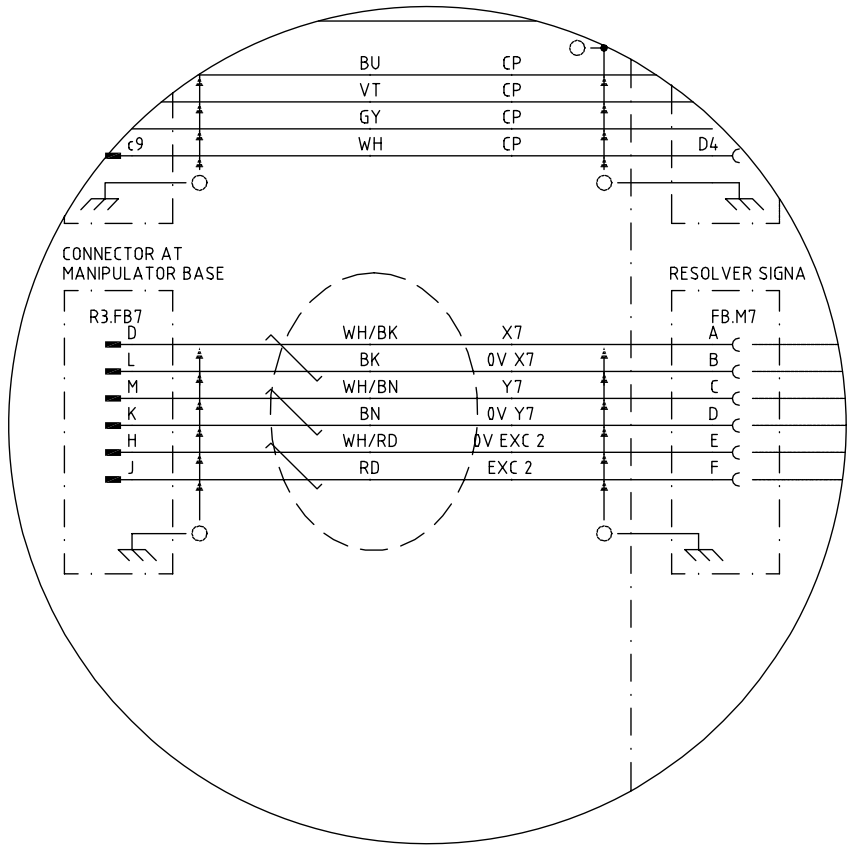

NOTE 1.18

LOWER ARM HARNESS
PARALLEL COMMUNICATION, HSe
3HAC16425-1, REV.00

We reserve all rights in this document and in the information contained therein. Reproduction or disclosure to third parties without express authority is strictly forbidden. © Copyright 2019 ABB

Prepared by, date C Blanksvärd, 050316	Responsible department ATMA/RO/AB	Description ACC SpotPack for servo gun SpotPack för servotång	Circuit Diagram
Approved by, date M Thunell, 050406	Take over department		
Status Approved		Document No. 3HAC17669-1	Sheet 956 No. of sh. 975 Rev. ind. 03

DESIGN CHANGES, NOTE 1.18
KONSTRUKTIONSÄNDRINGAR, NOT 1.18
IRB 6600/6650/7600

Latest Revision

ABB ABB Automation Technologies AB

3HAC17669-1

Cable

CP/CS

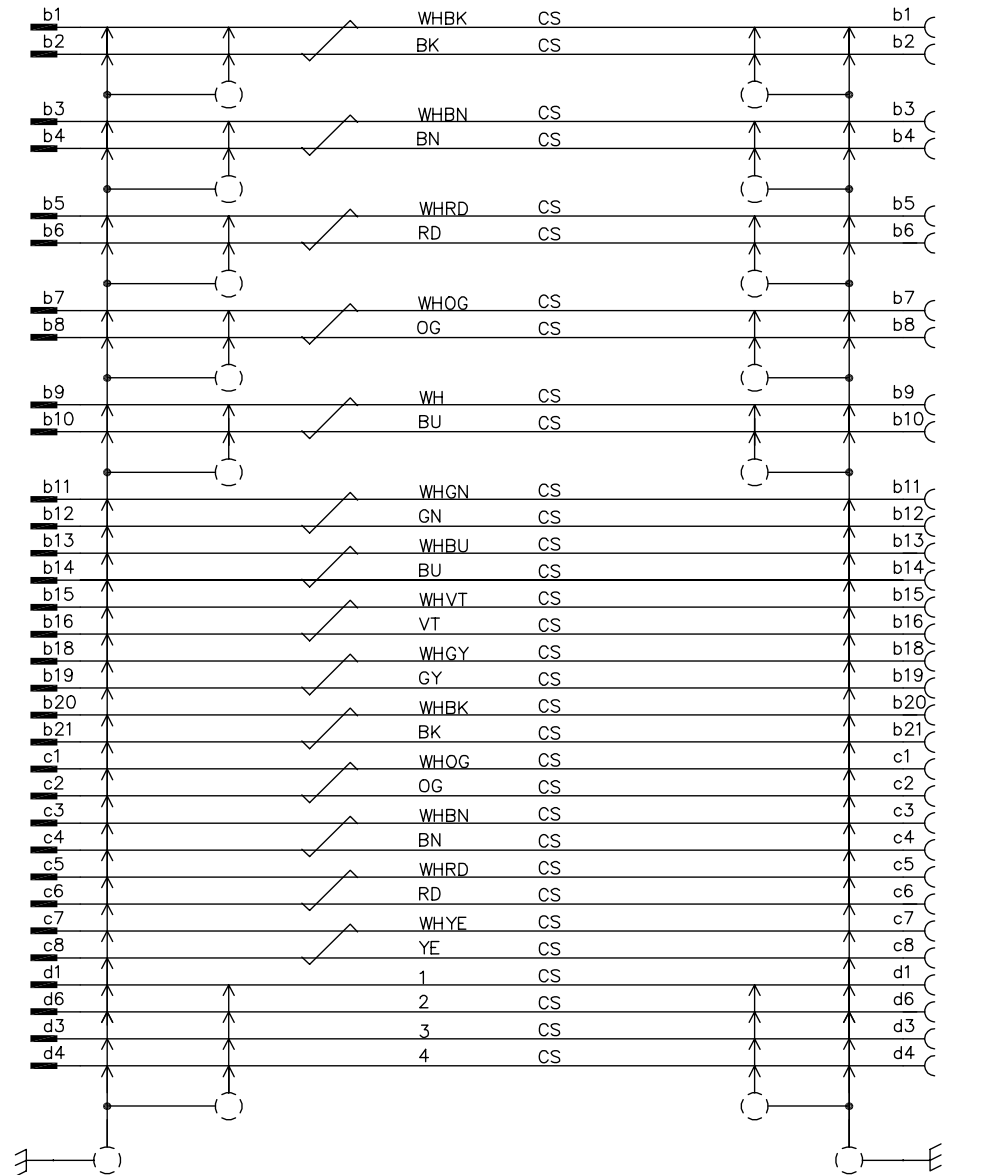

Cable

CP

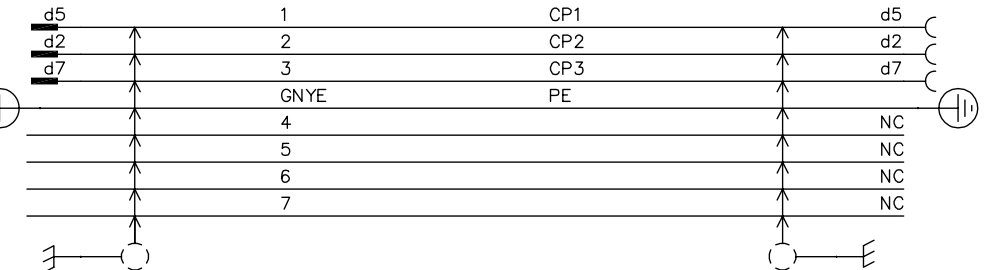

Cable

CBUS

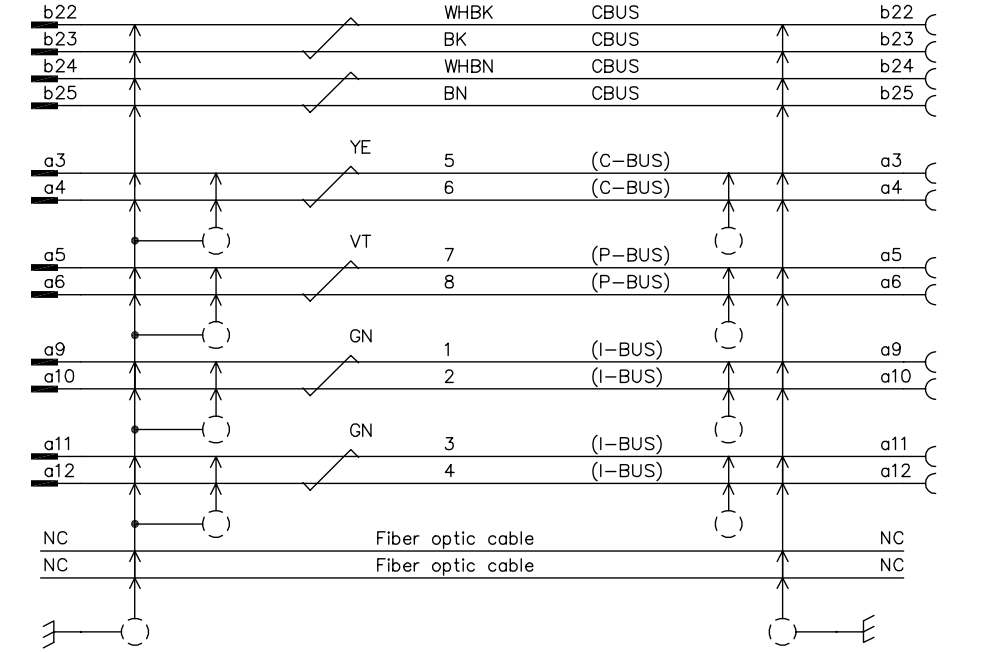

LOWER ARM HARNESS
 3HAC020126-001 REV.00,01
 3HAC020304-001 REV.00,01,02

Prepared by, date C Blanksvärd, 050316	Responsible department ATMA/RO/AB	Description ACC	Circuit Diagram
Approved by, date M Thunell, 050406	Take over department		
Status Approved		SpotPack for servo gun SpotPack för servotång	Sheet 970 No. of sh. 975 Rev. ind. 03
Document No. ABB ABB Automation Technologies AB		3HAC17669-1	

We reserve all rights in this document, and in the information contained therein. Reproductions, use or disclosure to third parties without express authority is strictly forbidden. © Copyright 2002 ABB

CUSTOMER POWER/SIGNAL, AX1-3 MH EXT
 KUNDKABLAGE KRAFT/SIGNAL, AX1-3 MH EXT
 IRB 6600/6650/7600

Latest Revision

Cable CP/CS

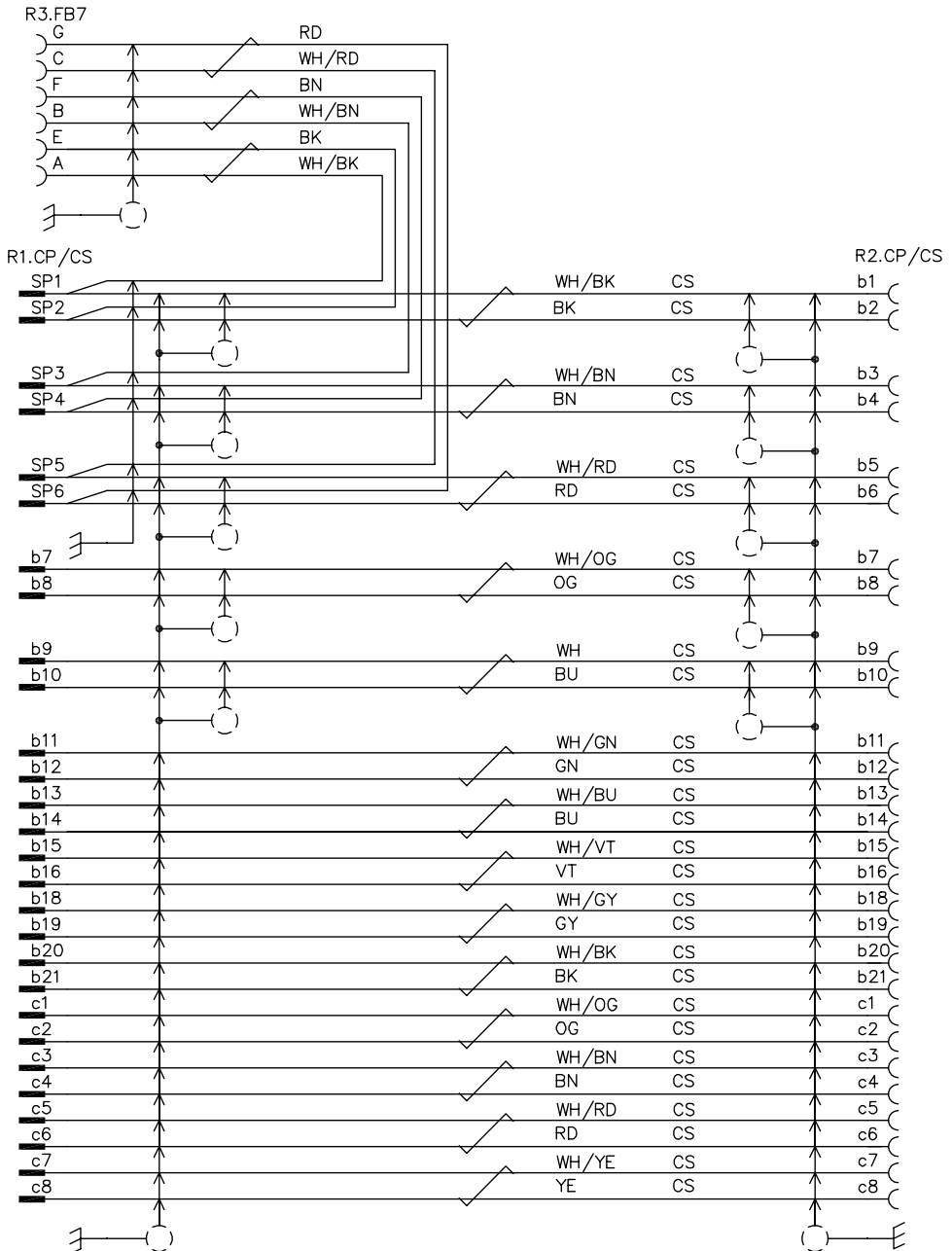

Cable CP

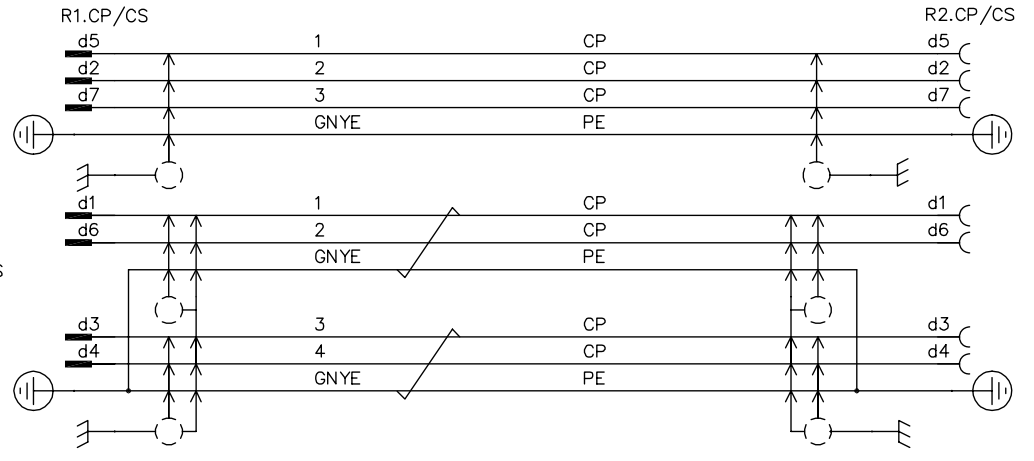

Cable FB

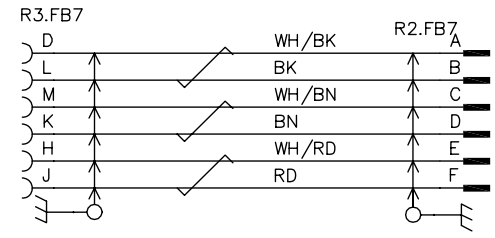

LOWER ARM HARNESS
 3HAC16782-1 REV.01
 3HAC16783-1 REV.02
 3HAC16788-1 REV.01
 3HAC16789-1 REV.02

Prepared by, date C Blanksvård, 050316	Responsible department ATMA/R0/AB	Description ACC SpotPack for servo gun SpotPack för servotång	Circuit Diagram
Approved by, date M Thunell, 050406	Take over department		
Status Approved		Document No. 3HAC17669-1	Sheet 971 No. of sh. 975 Rev. ind. 03

CUSTOMER POWER/SIGNAL, LOWER ARM CP/CBU+SERVOS
 KUNDKABLAGE KRAFT/SIGNAL, UNDERARM CP/CBUS+SERVO
 IRB 6600/6650/7600

Latest Revision

ABB ABB Automation Technologies AB

We reserve all rights in this document, and in the information contained therein. Reproductions, use or disclosure to third parties without express authority is strictly prohibited. © Copyright 2012 ABB

Cable FB

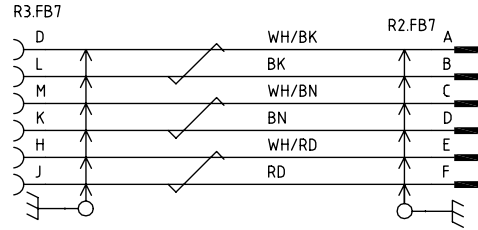

We reserve all rights in this document and in the information contained therein. Reproductions or disclosures to third parties without express authority is strictly forbidden. © Copyright 2019 ABB

LOWER ARM HARNESS
3HAC020447-001 REV.01

Prepared by, date C Blanksvärd, 050316	Responsible department ATMA/RO/AB	Description ACC Circuit Diagram	Sheet 972
Approved by, date M Thunell, 050406	Take over department		No. of sh. 975
Status Approved		Document No. 3HAC17669-1	Rev. ind. 03

7th AXIS, SERIAL CABLE
..7:e AXIS, SERIEMÅTKABEL
IRB 6600/6650/7600

Latest Revision

ABB ABB Automation Technologies AB

Cable CP/CS

R1.CP/CS

R2.CP/CS

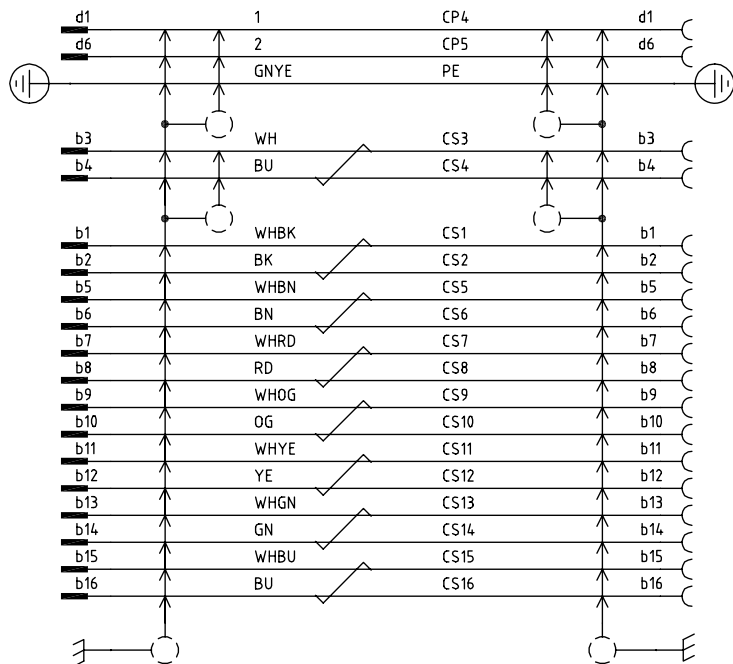

We reserve all rights in this document and in the information contained therein. Reproductions or disclosures to third parties without express authority is strictly forbidden. © Copyright 2012 ABB

LOWER ARM HARNESS
 3HAC020179-001 REV.00,01
 3HAC020303-001 REV.00,01,02

Prepared by, date C Blanksvärd, 050316	Responsible department ATMA/RO/AB	Description ACC Circuit Diagram	Sheet 973
Approved by, date M Thunell, 050406	Take over department		No. of sh. 975
Status Approved		Document No. 3HAC17669-1	Rev. ind. 03

CUSTOMER POWER/SIGNAL, AX1-3 MH STD
 KUNDKABLAGE KRAFT/SIGNAL/BUS, AX1-3 MH STD
 IRB 6600/6650/7600

Latest Revision

ABB ABB Automation Technologies AB

Cable CP/CS

R2.CP/CS

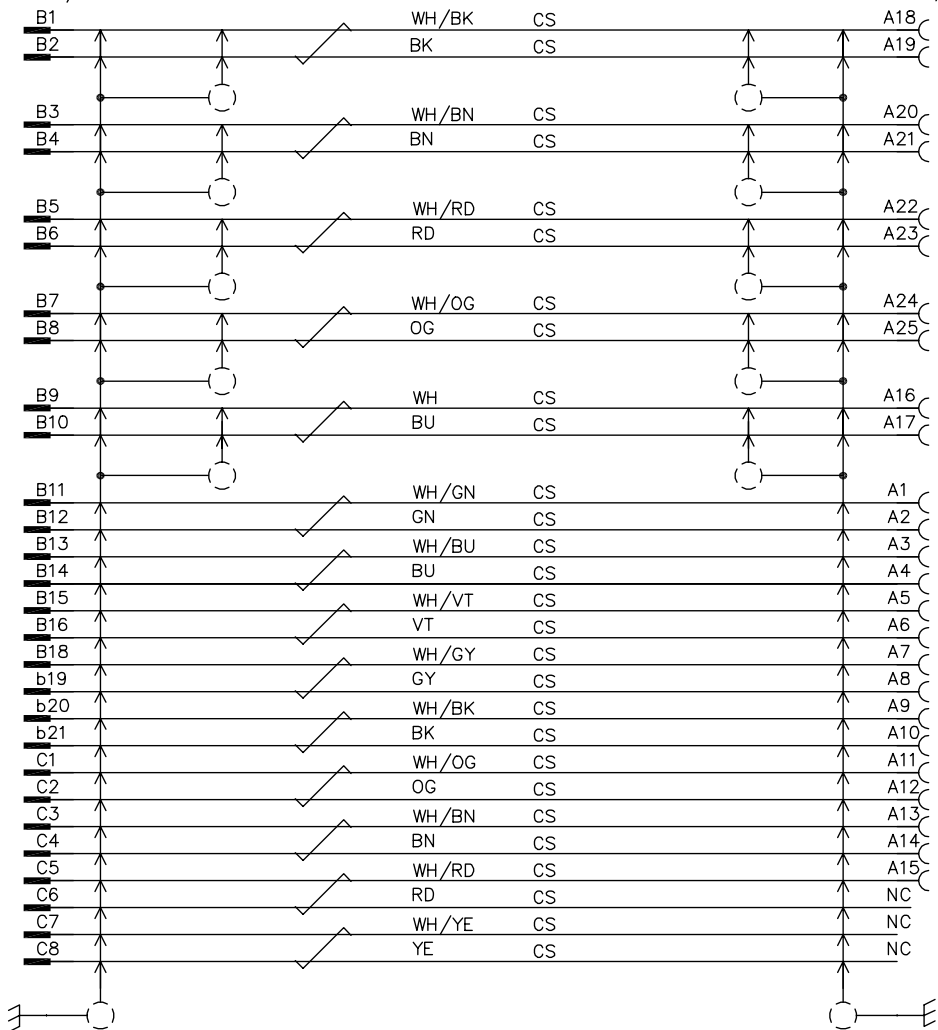

Cable CP

R2.CP/CS

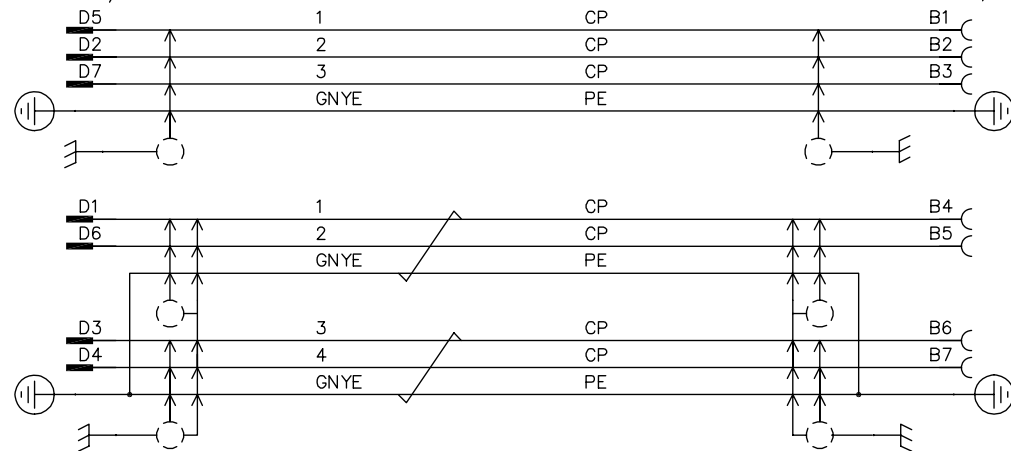

UPPER ARM HARNESS
 3HAC16643-1,-2,-3 REV.03,04
 3HAC16645-1,-2,-3 REV.02,03
 3HAC16647-1,-2,-3,-4,-5 REV.02,03

We reserve all rights in this document, and in the information contained therein. Reproductions, use or disclosure to third parties without express authority is strictly forbidden. © Copyright 2012 ABB

CUSTOMER POWER/SIGNAL, UPPER ARM CP/CS
 KUNDKABLAGE KRAFT/SIGNAL/BUS, ÖVERARM CP/CS
 IRB 6600/6650/7600

Latest Revision

Prepared by, date C Blanksvärd, 050316	Responsible department ATMA/R0/AB	Description ACC SpotPack for servo gun SpotPack för servotång	Circuit Diagram
Approved by, date M Thunell, 050406	Take over department		
Status Approved		Document No. 3HAC17669-1	No. of sh. 974 Rev. ind. 03

ABB ABB Automation Technologies AB

Cable
CP

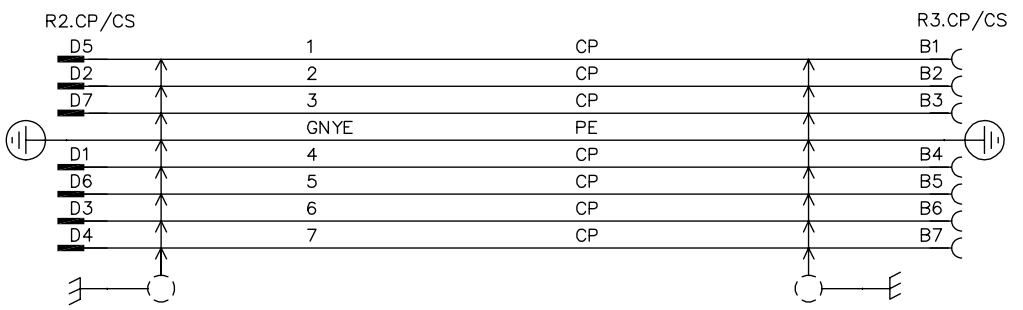

Cable
CBUS

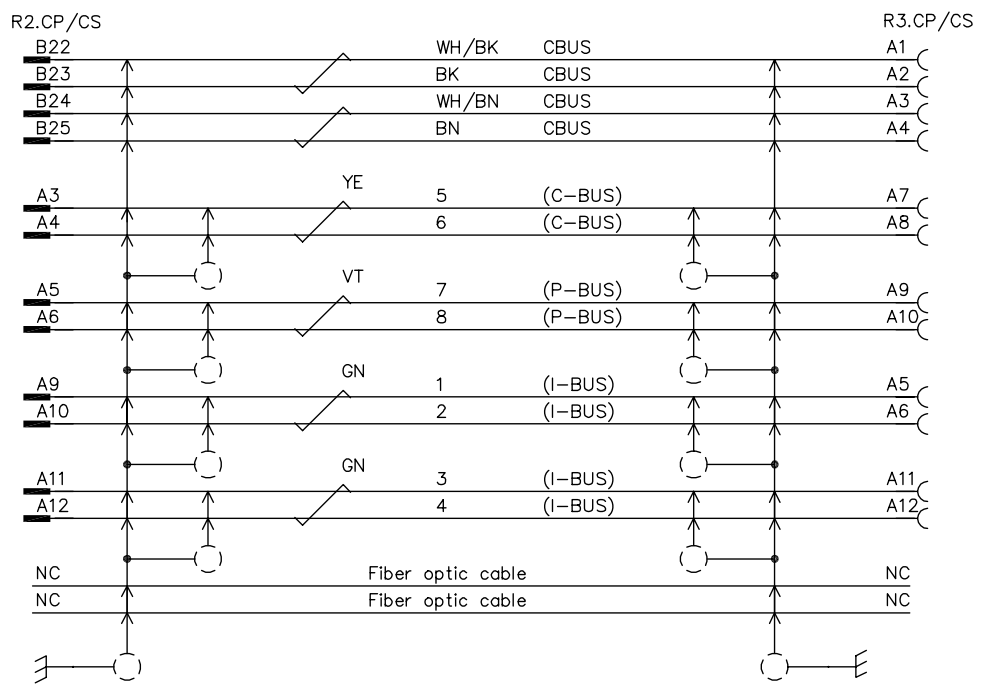

- UPPER ARM HARNESS
- 3HAC16644-1 REV.00,01,02,03
 - 3HAC16644-2 REV.00,01,02
 - 3HAC16644-3 REV.00,01,02
 - 3HAC16646-1 REV.00,01,02
 - 3HAC16646-2 REV.00,01,02
 - 3HAC16646-3 REV.00,01,02
 - 3HAC16648-1 REV.00,01,02
 - 3HAC16648-2 REV.00,01,02
 - 3HAC16648-3 REV.00,01,02
 - 3HAC16648-4 REV.00,01,02
 - 3HAC16648-5 REV.00,01,02

We reserve all rights in this document and in the information contained therein. Reproductions, use or disclosure to third parties without express authority is strictly prohibited. © Copyright 2012 ABB

Prepared by, date C Blanksvärd, 050316	Responsible department ATMA/RO/AB	Description ACC SpotPack for servo gun SpotPack för servotång	Circuit Diagram
Approved by, date M Thunell, 050406	Take over department		
Status Approved		Document No. 3HAC17669-1	No. of sh. 975 Rev. ind. 03

CUSTOMER POWER/SIGNAL, UPPER ARM CP/CBUS
KUNDKABLAGE KRAFT/SIGNAL, ÖVERARM CP/CBUS
IRB 6600/6650/7600

Latest Revision

ABB ABB Automation Technologies AB

A

CHAPTER CONTENTS

0	GENERAL INFORMATION
1	BLOCK DIAGRAM
2	CABINET LAYOUT
3	PART LIST, PART LIST OUTSIDE CABINET AND OPTION LIST
4	MAIN CIRCUITS
5	CONTROL CIRCUITS
6	CONTROL CIRCUITS PROCESS EQUIPMENT
7	I/O CIRCUITS
9	CABLES AND EXTERNAL CONNECTIONS

B

C

D

We reserve all rights in this document and in the information contained therein. Reproduction, use or disclosure to third parties without express authority is strictly forbidden. © Copyright 2003 ABB

Prepared by, date C Blanksvärd, 050218	Responsible department ATMA/RO/AB	Description ACC SpotPack for pneum. gun SpotPack för pneum.fång	Circuit Diagram 
Approved by, date M Thunell, 050330	Take over department		
Status Approved		Document No. 3HAC17669-2	Sheet 000 No. of sh. 953 Rev. ind. 03

1 BLOCK DIAGRAM

SHEET CONTENTS

101	BLOCK DIAGRAM ROBOT MOUNTED GUN, TYPE S
102	BLOCK DIAGRAM PEDESTAL GUN, TYPE HS
103	BLOCK DIAGRAM CONNECTOR LAYOUT, TYPE S/HS
104	BLOCK DIAGRAM POWER UNIT
105	BLOCK DIAGRAM WATER AND AIR UNIT

We reserve all rights in this document and in the information contained therein. Reproductions, use or disclosure to third parties without express authority is strictly forbidden. © Copyright 2003 ABB

Prepared by, date C Blanksvärd, 050316	Responsible department ATMA/R0/AB	Description ACC Circuit Diagram SpotPack for pneum. gun SpotPack för pneum.fång	 Sheet 100 No. of sh. 953
Approved by, date M Thunell, 050330	Take over department		
Status Approved		Document No. 3HAC17669-2	Rev. ind. 03

BLOCK DIAGRAM TYPE S

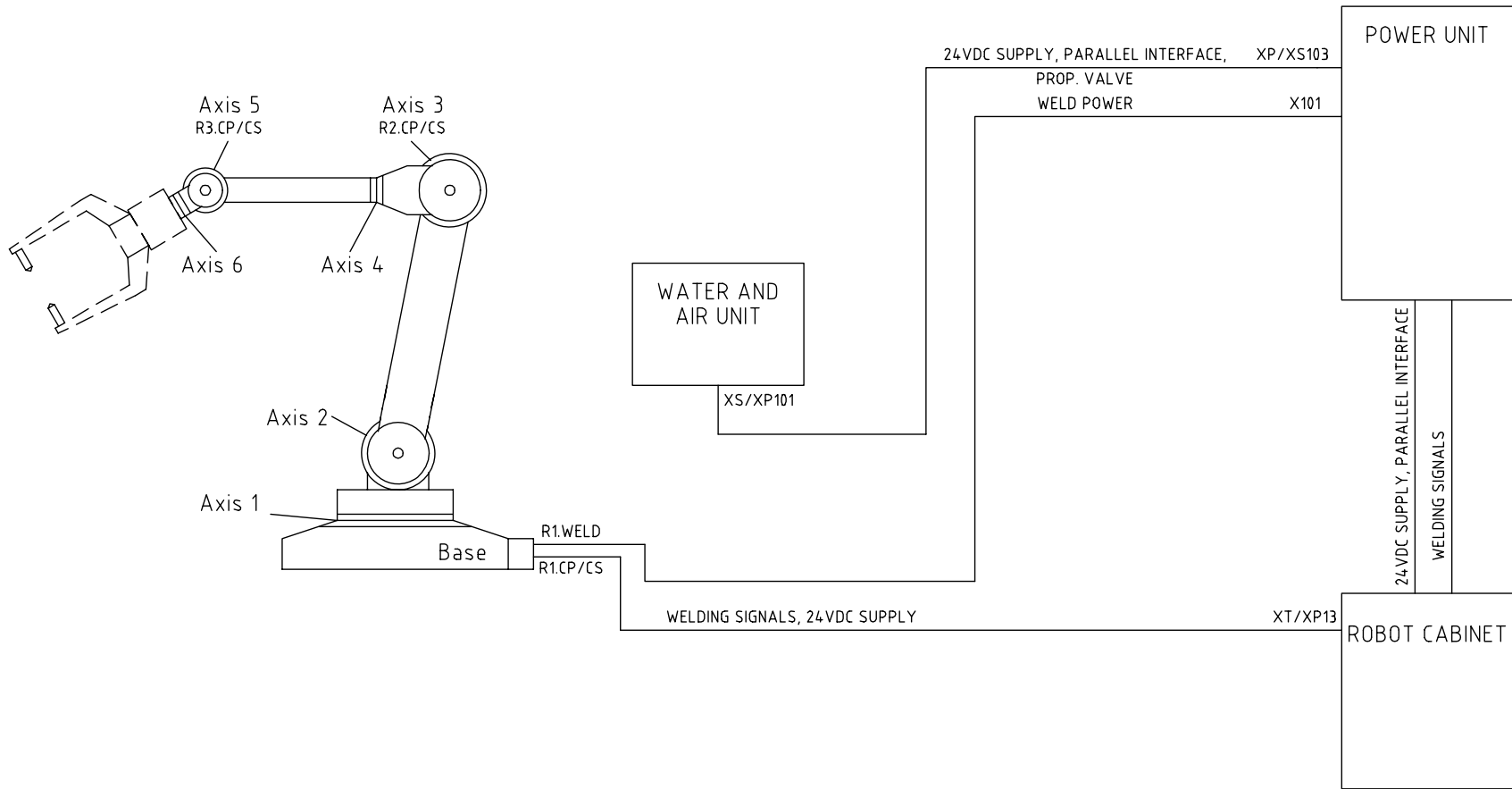

We reserve all rights in this document and in the information contained therein. Reproductions, use or disclosure to third parties without express authority is strictly forbidden. © Copyright 2003 ABB

ROBOT MOUNTED GUN TYPE S
BLOCK DIAGRAM
IRB 6600/6650/7600

Latest Revision

Prepared by, date C Blanksvärd, 050316	Responsible department ATMA/RO/AB	Description ACC SpotPack for pneum. gun SpotPack för pneum.fång	Circuit Diagram
Approved by, date M Thunell, 050330	Take over department		
Status Approved		Document No. 3HAC17669-2	Sheet 101 No. of sh. 953 Rev. ind. 03

We reserve all rights in this document and in the information contained therein. Reproductions, use or disclosure to third parties without express authority is strictly forbidden. © Copyright 2003 ABB

BLOCK DIAGRAM TYPE HS

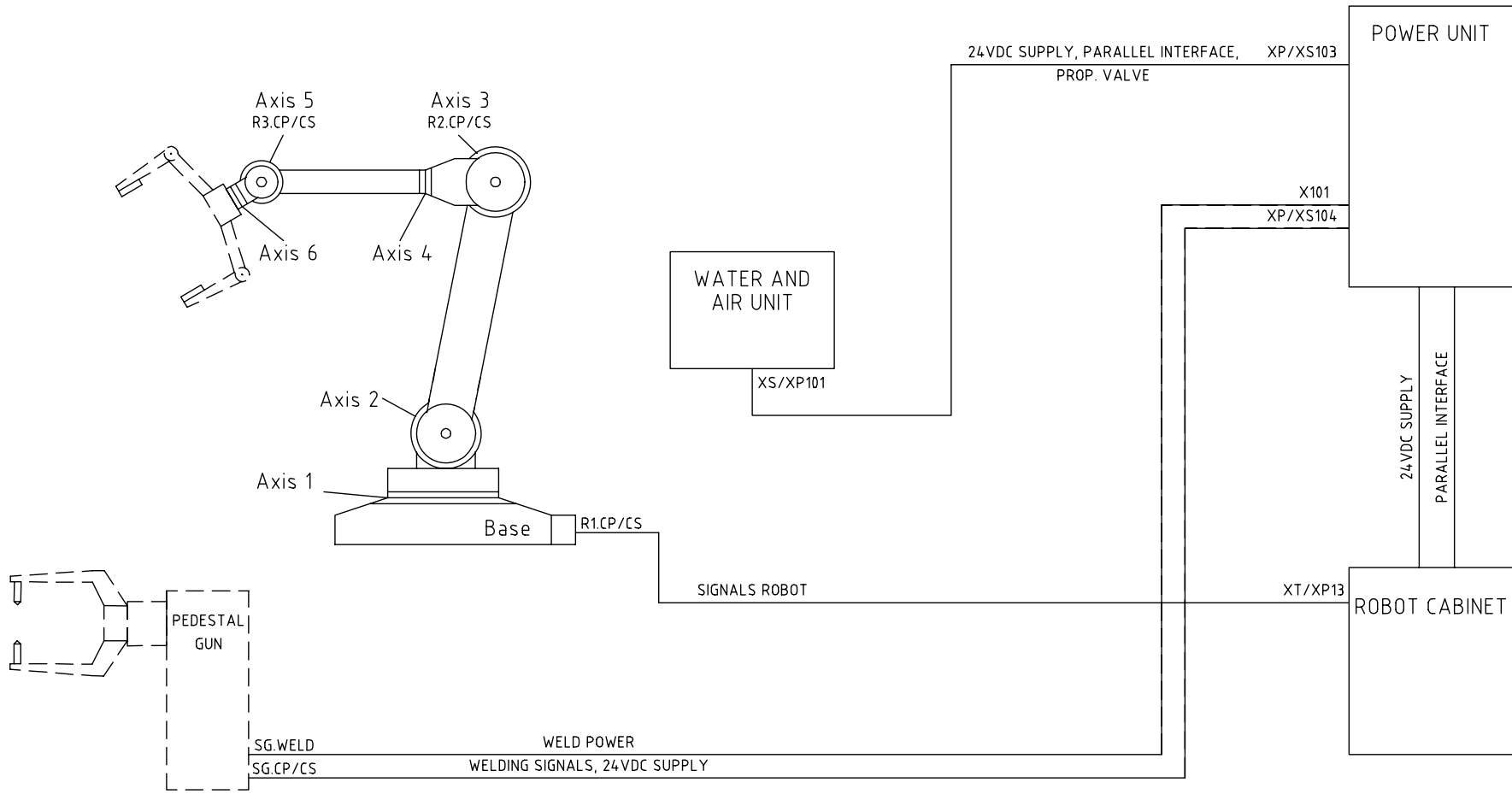

PEDESTAL GUN TYPE HS
 BLOCK DIAGRAM
 IRB 6600/6650/7600

Latest Revision

Prepared by, date C Blanksvård, 050316	Responsible department ATMA/RO/AB	Description ACC SpotPack for pneum. gun SpotPack för pneum.fång	Circuit Diagram
Approved by, date M Thunell, 050330	Take over department		
Status Approved		Document No. 3HAC17669-2	No. of sh. 102 No. of sh. 953 Rev. ind. 03

ABB ABB Automation Technologies AB

We reserve all rights in this document and in the information contained therein. Reproduction, use or disclosure to third parties without express authority is strictly forbidden. © Copyright 2015 ABB

BLOCK DIAGRAM TYPE S/HS

Male (R1.CP/CS)

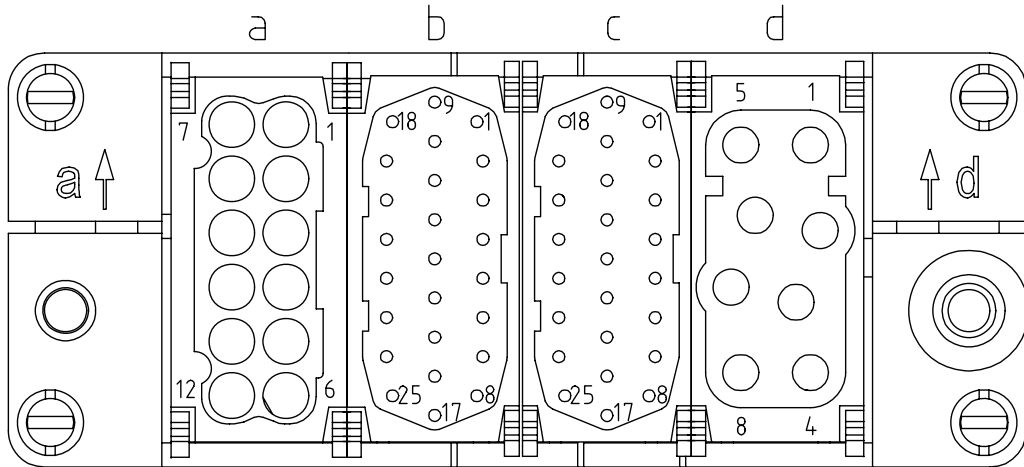

HARTING HAN MODULE / DD HD HD EE

Axis 6 (CP/CS)

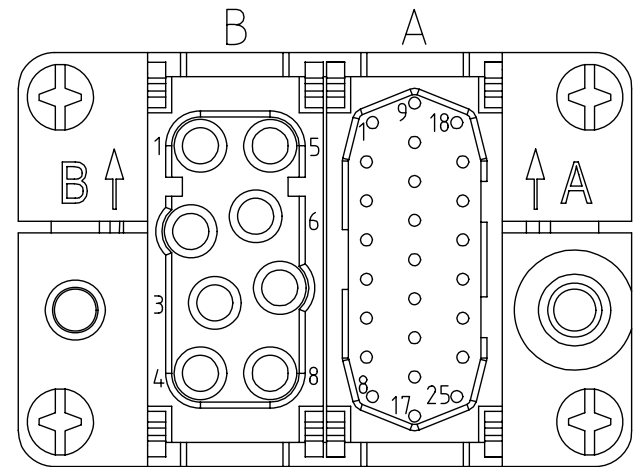

EE HD

Female (R2.CP/CS)

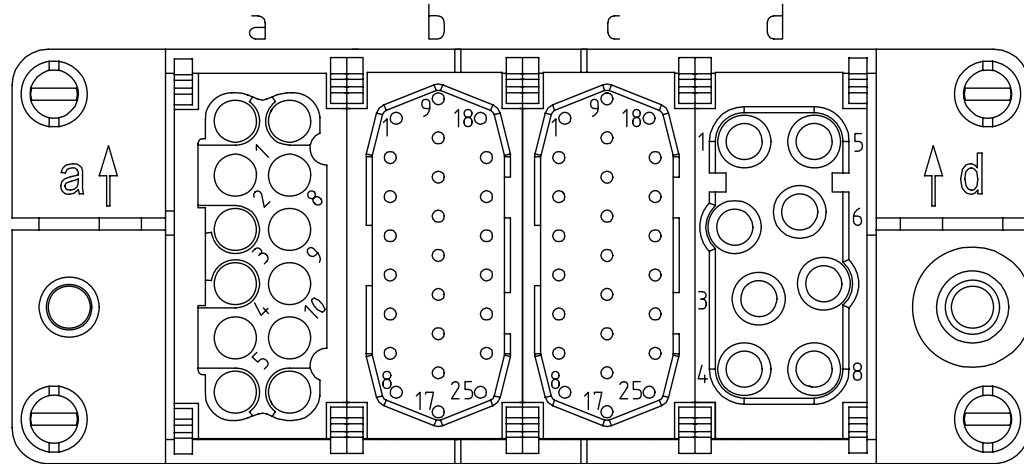

HARTING HAN MODULE / DD HD HD EE

Axis 6 (CP/Cbus)

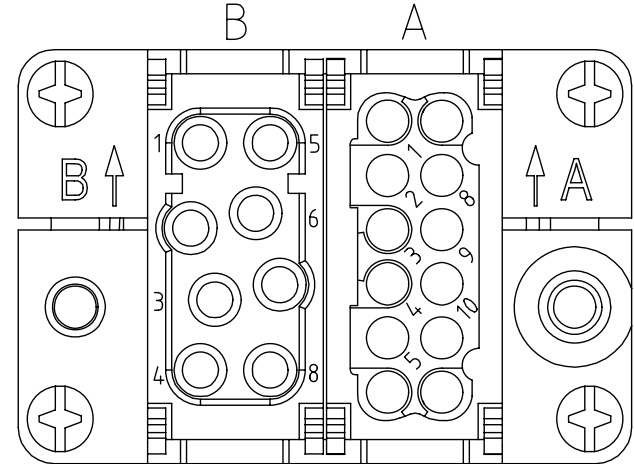

EE HD

POWER UNIT
BLOCK DIAGRAM
IRB 6600/6650/7600

Latest Revision

Prepared by, date C Blanksvård, 050316	Responsible department ATMA/RO/AB EE	Description DD ACC	Circuit Diagram
Approved by, date M Thunell, 050330	Take over department	SpotPack for pneum. gun SpotPack för pneum.fång	Sheet 103
Status Approved		Document No. 3HAC17669-2	No. of sh. 953
ABB Automation Technologies AB			Rev. ind. 03

We reserve all rights in this document and in the information contained therein. Reproduction, use or disclosure to third parties without express authority is strictly forbidden. © Copyright 2015 ABB

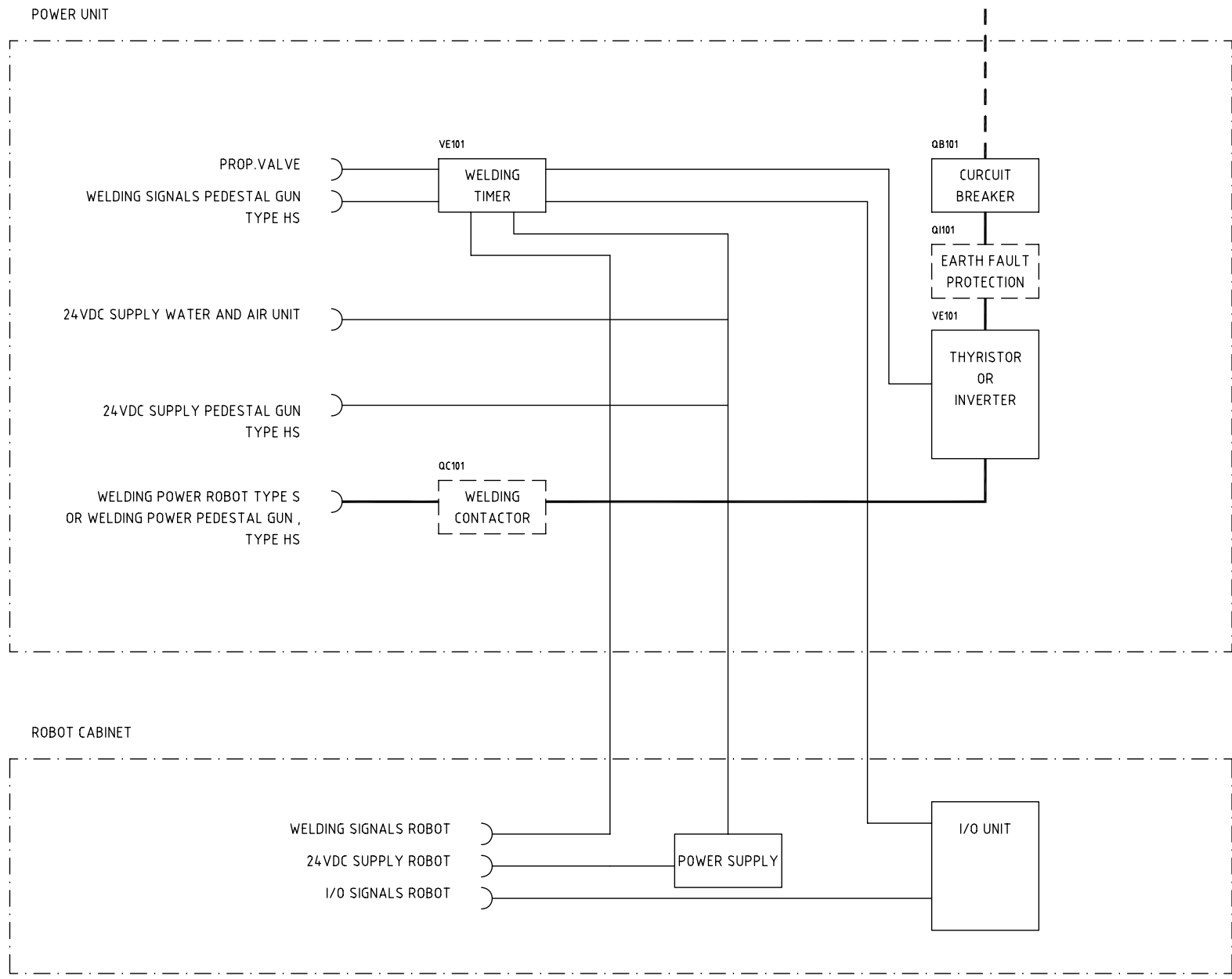

POWER UNIT
 BLOCK DIAGRAM
 IRB 6600/6650/7600

Latest Revision

Prepared by, date C Blanksvärd, 050316	Responsible department ATMA/RO/AB	Description ACC SpotPack for pneum. gun SpotPack för pneum.fång	Circuit Diagram
Approved by, date M Thunell, 050330	Take over department		
Status Approved		Document No. 3HAC17669-2	No. of sh. 104 No. of sh. 953 Rev. ind. 03

WATER AND AIR UNIT FOR ROBOT MOUNTED GUN OR PEDESTAL GUN

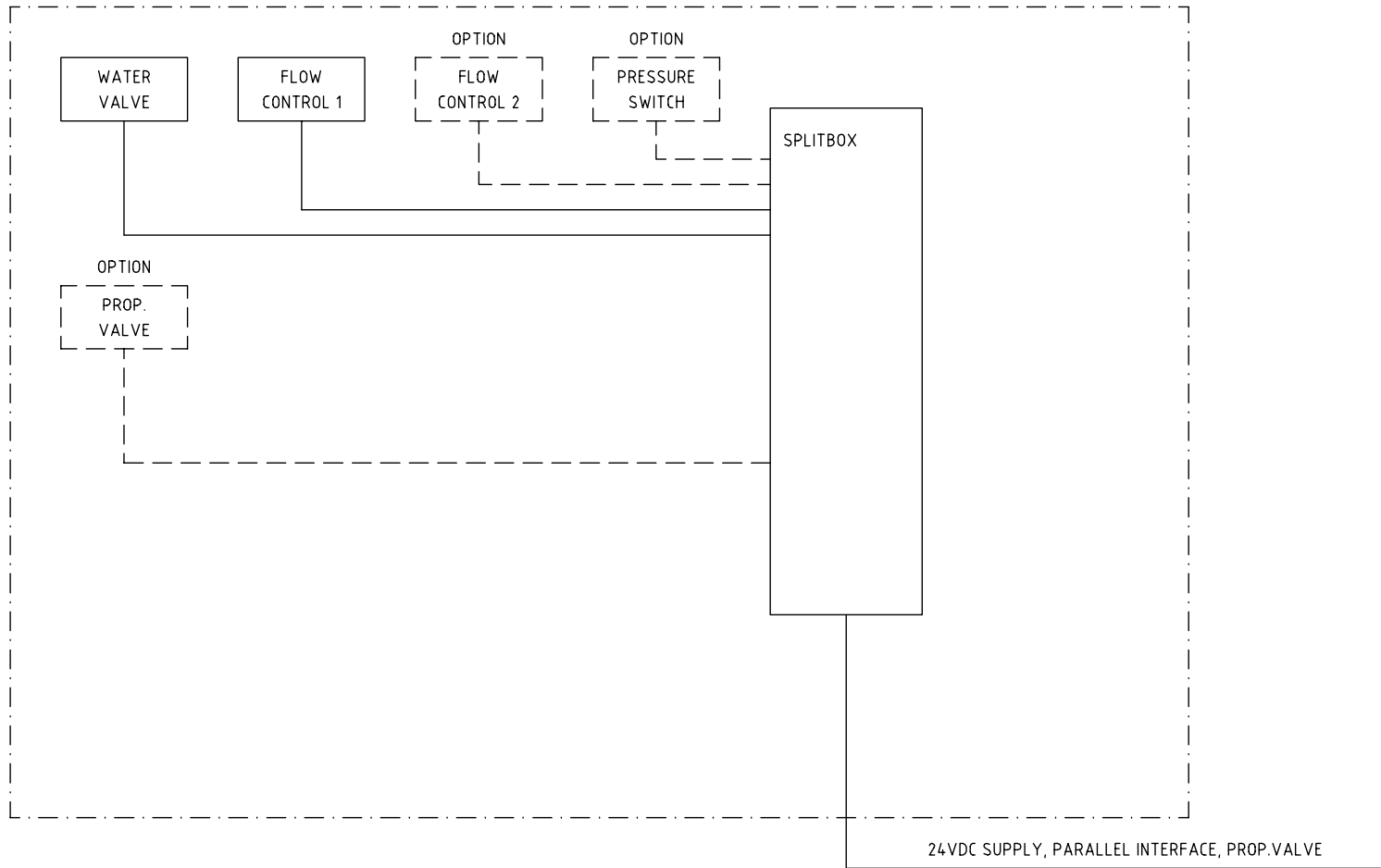

We reserve all rights in this document and in the information contained therein. Reproduction, use or disclosure to third parties without express authority is strictly forbidden. © Copyright 2003 ABB

WATER AND AIR UNIT
BLOCK DIAGRAM
IRB 6600/6650/7600

Latest Revision

Prepared by, date C Blanksvärd, 050316	Responsible department ATMA/RO/AB	Description ACC SpotPack for pneum. gun SpotPack för pneum.fång	Circuit Diagram
Approved by, date M Thunell, 050330	Take over department		
Status Approved		Document No. 3HAC17669-2	Sheet 105 No. of sh. 953 Rev. ind. 03

ABB ABB Automation Technologies AB

A

2 CABINET LAYOUT

SHEET CONTENTS

201 CABINET LAYOUT

202 CABINET LAYOUT

B

A

B

C

D

We reserve all rights in this document and in the information contained therein. Reproduction, use or disclosure to third parties without express authority is strictly forbidden. © Copyright 2003 ABB

Prepared by, date C Blanksvärd, 050316	Responsible department ATMA/R0/AB	Description ACC SpotPack for pneum. gun SpotPack för pneum.fång	Circuit Diagram 
Approved by, date M Thunell, 050330	Take over department		
Status Approved	Document No. 3HAC17669-2		Sheet 200 No. of sh. 953 Rev. ind. 03

We reserve all rights in this document and in the information contained therein. Reproduction, use or disclosure to third parties without express authority is strictly forbidden. © Copyright 2015 ABB

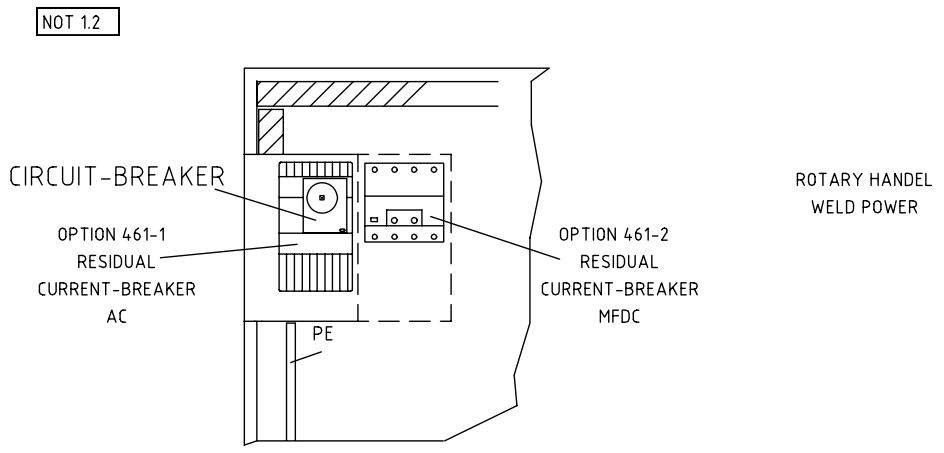
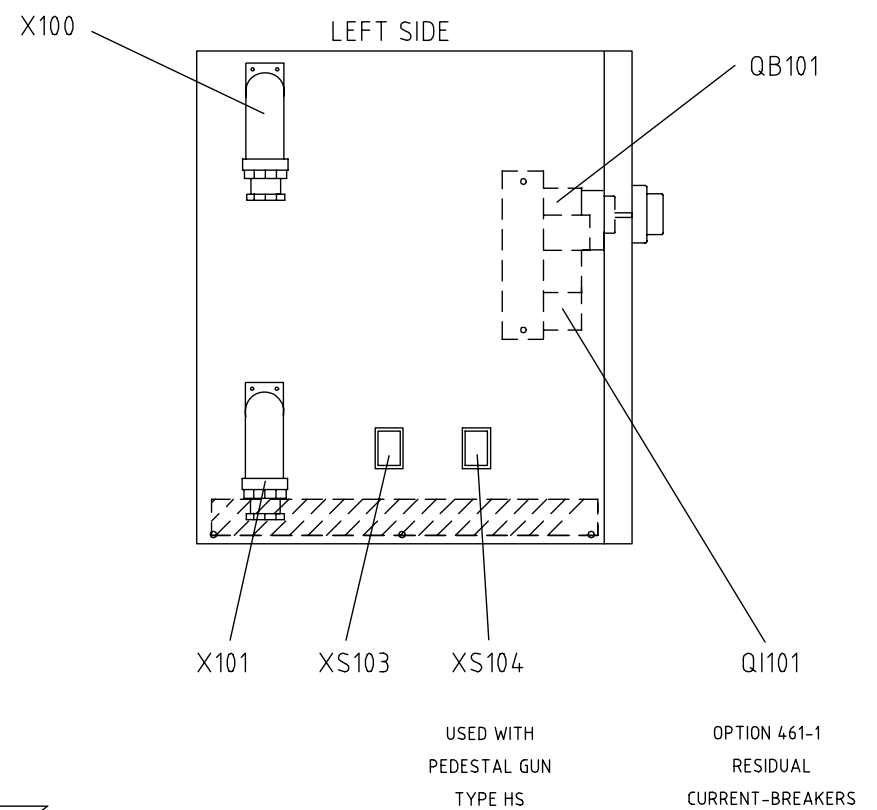
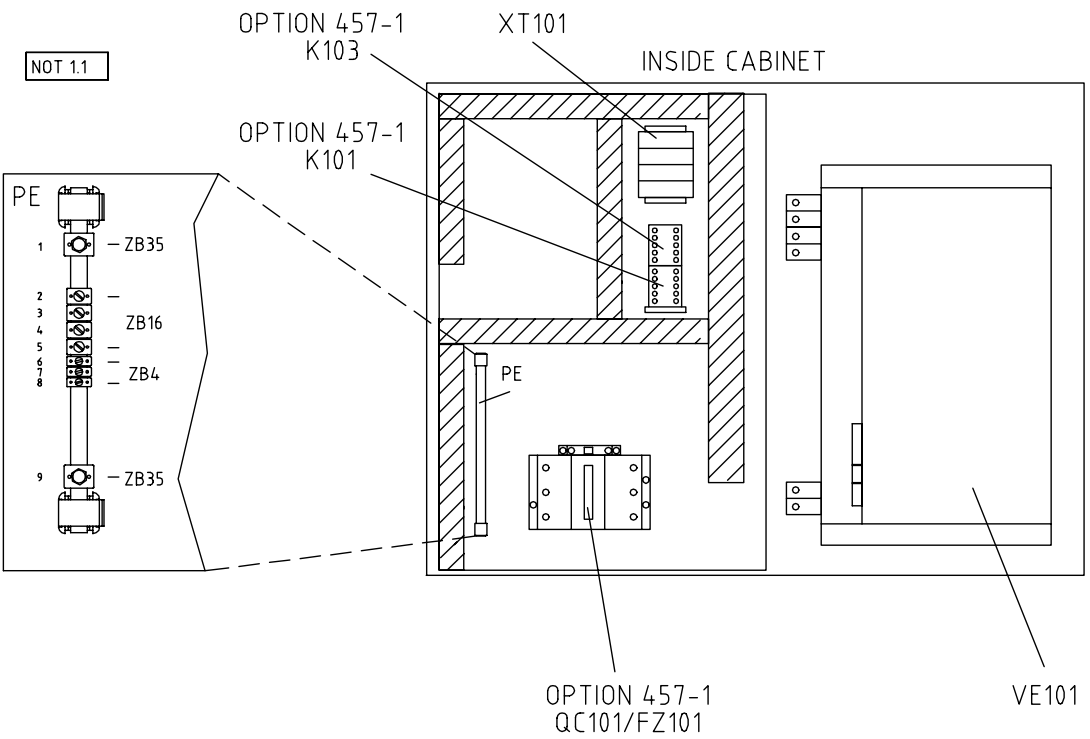

POWER UNIT
CABINET LAYOUT
IRB 6600/6650/7600

Latest Revision

Prepared by, date C Blanksvärd, 050316	Responsible department ATMA/RO/AB	Description ACC SpotPack for pneum. gun SpotPack för pneum.fång	Circuit Diagram
Approved by, date M Thunell, 050330	Take over department		
Status Approved	Document No. 3HAC17669-2		Sheet 201 No. of sh. 953 Rev. ind. 03

We reserve all rights in this document and in the information contained therein. Reproduction, use or disclosure to third parties without express authority is strictly forbidden. © Copyright 2015 ABB

BACKSIDE

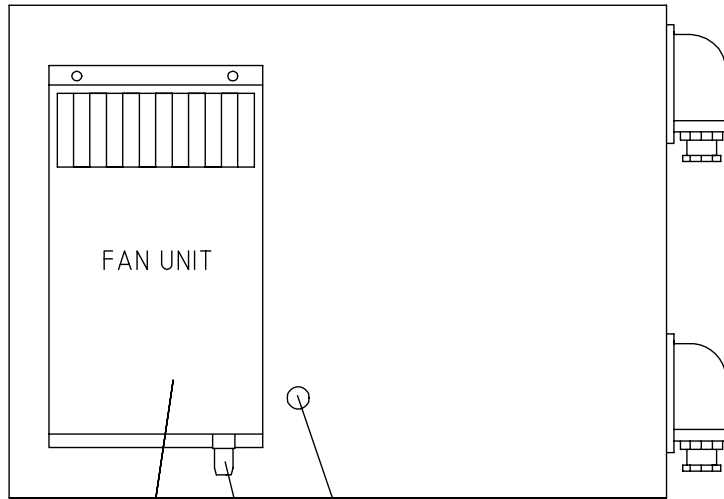

FU100 XP/XS100 X103

OPTION 461-1
COOLING FAN FOR WELDING INVERTER
OR THYRISTOR , INCLUDE CONNECTOR XP/XS100
AND X103 CABLE GLAND

POWER UNIT
CABINET LAYOUT
IRB 6600/6650/7600

Latest Revision

Prepared by, date C Blanksvärd, 050316	Responsible department ATMA/R0/AB	Description ACC SpotPack for pneum. gun SpotPack för pneum.fång	Circuit Diagram
Approved by, date M Thunell, 050330	Take over department		
Status Approved	Document No. 3HAC17669-2		Sheet 202 No. of sh. 953 Rev. ind. 03

ABB ABB Automation Technologies AB

A

3 PART LIST, PART LIST OUTSIDE CABINET AND OPTION LIST

SHEET CONTENTS

- 301 PART LIST, POWER UNIT
- 302 ADJUSTMENT PROCEEDING
- 303 PART LIST OUTSIDE CABINET
- 304 OPTION LIST

B

We reserve all rights in this document and in the information contained therein. Reproduction, use or disclosure to third parties without express authority is strictly forbidden. © Copyright 2003 ABB

C

D

Prepared by, date C Blanksvärd, 050316	Responsible department ATMA/R0/AB	Description ACC SpotPack for pneum. gun SpotPack för pneum.fång	Circuit Diagram 
Approved by, date M Thunell, 050330	Take over department		
Status Approved		Document No. 3HAC17669-2	Sheet 300 No. of sh. 953 Rev. ind. 03

We reserve all rights in this document and in the information contained therein. Reproduction, use or disclosure to third parties without express authority is strictly forbidden. © Copyright 2003 ABB

POS	QUANTITY	DESCRIPTION	PRODUCT/ SUPPLIER	TYPE/ DATA	REMARK
<i>Components in power cabinet.</i>					
	1	CABINET	ABB	SDLN 528301- KV	600x800x530 mm
QB101	1	CIRCUIT-BREAKER (MAIN SWITCH)	ABB	T1N 160 F FC Cu R125	WELDING POWER ONLY
	1	AUXILIARY CONTACTS	ABB	TYPE AUX	
	1	ROTARY HANDLE	ABB	NORMAL RHE	
(QI101)	1	RESIDUAL CURRENT -BREAKER	ABB	RC 221/1 50-60Hz RC 212/1 50-5000Hz	Ver. 50-5000Hz if MFDC is used
VE101	1	THYRISTOR OR INVERTER	BOSCH	*	* SEE OPTION LIST
(FU100)	1	FAN UNIT	ABB	SDLN529201-GV	
(X103)	1	CABEL GLAND		CABEL GLAND M16 + NUT	COOLING FAN
(QC101)	1	(WELDING) CONTACTOR	ABB	A110-30-11 220-230V 50-60 Hz	
	1	AUXILIARY CONTACTS	ABB	CAL5-11	
(FZ101)	1	SURGE SUPPRESSOR	ABB	RC-EH250/415 110-415V	
(K101)	1	INTERFACE CONTACTOR RELAY	ABB	K6S-40E1,7	WITH DIODE
(K103)	1	INTERFACE CONTACTOR RELAY	ABB	K6S-40E1,7	WITH DIODE
X100	1	GLAND PLATES + CABLE GLAND		FLV 13140 + CABLE GLAND 40mm	CABLE DIM.23-34mm
X101	1	GLAND PLATES + CABLE GLAND		FLV 13140 + CABLE GLAND 40mm	CABLE DIM.23-34mm
XT101	4	TERMINALFUSE 24Vdc	WEIDMÜLLER	WSI 6	SUPPLY 24Vdc (2AT)
	4	TERMINAL	WEIDMÜLLER	WDU 2.5	
XS103	1	CONNECTOR	HARTING	HOUSING	WATER AND AIR UNIT , PROP.VALE
	1			HAN DD MODULE / 12-Pol	
	7			FEMALE CONTACT	
(XS104)	1	CONNECTOR	HARTING	HOUSING	USED WIHT PEDESTAL GUN
	1			HAN HD MODULE / 25-Pol	TYPE HS
	12+2			FEMALE CONTACT	

POWER UNIT
PART LIST
IRB 6600/6650/7600

Latest Revision

Prepared by, date C Blanksvärd, 050316	Responsible department ATMA/RO/AB	Description ACC SpotPack for pneum. gun SpotPack för pneum.fång	Circuit Diagram 
Approved by, date M Thunell, 050330	Take over department		
Status Approved	Document No. 3HAC17669-2		No. of sh. 301 953 Rev. ind. 03

ABB ABB Automation Technologies AB

PART LIST OUTSIDE CABINET

DESIGNATION	SUPPLIER	TYPE / DATA	REMARKS	
XP103	CONNECTOR FOR WATER AND AIR UNIT PROP. VALVE	HARTING	CARRIER HOOD HOOD HAN DD MODULE MALE CONTACTS CABLE GLAND M25	SIDE ENTRY 12-POL
XP104	CONNECTOR FOR KSR / WELDING SIGNALS	HARTING	CARRIER HOOD HOOD HAN HD MODULE MALE CONTACTS CABLE GLAND M25	SIDE ENTRY 25-POL
XS100	CONNECTOR FOR FAN UNIT	HARTING	HOOD HAN 3A TERMINAL SIZE 3A CABLE GLAND Pg11	3-POL + PE
XP100	CONNECTOR FOR FAN UNIT	HARTING	HOOD HAN 3A TERMINAL SIZE 3A	3-POL + PE

We reserve all rights in this document and in the information contained therein. Reproduction, use or disclosure to third parties without express authority is strictly forbidden. © Copyright 2003 ABB

POWER UNIT
 PARTLIST OUTSIDE CABINET
 IRB 6600/6650/7600

Latest Revision

Prepared by, date C Blanksvärd, 050316	Responsible department ATMA/R0/AB	Description ACC SpotPack for pneum. gun SpotPack för pneum.fång	Circuit Diagram 
Approved by, date M Thunell, 050330	Take over department		
Status Approved	Document No. 3HAC17669-2		No. of sh. 303 953 Rev. ind. 03



4 MAIN CIRCUITS

SHEET CONTENTS

401 MAIN CIRCUITS

We reserve all rights in this document and in the information contained therein. Reproduction, use or disclosure to third parties without express authority is strictly forbidden. © Copyright 2003 ABB

Prepared by, date C Blanksvärd, 050316	Responsible department ATMA/R0/AB	Description ACC SpotPack for pneum. gun SpotPack för pneum.fång	Circuit Diagram 
Approved by, date M Thunell, 050330	Take over department		
Status Approved	Document No. 3HAC17669-2		Sheet 400 No. of sh. 953 Rev. ind. 03

We reserve all rights in this document and in the information contained therein. Reproduction, use or disclosure to third parties without express authority is strictly forbidden. © Copyright 2015 ABB

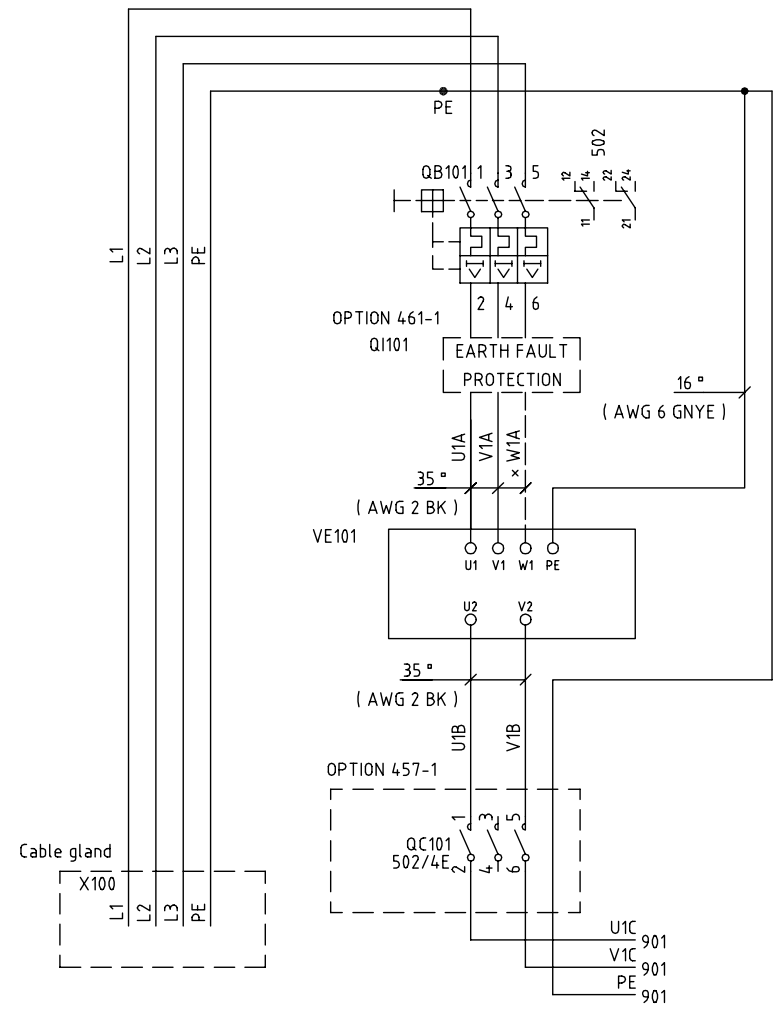

MIN AND MAX VOLTAGE
 FOR THYRISTOR 400-600 VAC
 FOR INVERTER 400-480 VAC
 MAX CURRENT FEED 160 A
 MAX SHORT-CIRCUIT-CURRENT 35ka

WELD POWER 1
 110A RMS



×W1A USED WITH MFDC INVERTERS

CABLE COLOR

L1 , L2 , L3	BLACK
NEUTRAL	GREY
230 VAC CONTR. CIRC.	GREY
24 VDC CONTR. CIRC.	BLUE
GROUND / PE	GREEN/YELLOW

POWER UNIT
 MAIN CIRCUIT
 IRB 6600/6650/7600

Latest Revision

Prepared by, date C Blanksvård, 050318	Responsible department ATMA/RO/AB	Description ACC Circuit Diagram	 Sheet 401
Approved by, date M Thunell, 050330	Take over department		
Status Approved		Document No.	No. of sh. 977 Rev. ind. 03
 ABB Automation Technologies AB		3HAC17669-2	

5 CONTROL CIRCUIT

SHEET CONTENTS

- 501 POWER SUPPLY 24VDC
- 502 CONTROL CIRCUIT WELDING CONTACTOR
- 503 CONTROL CIRCUIT SAFETY

We reserve all rights in this document and in the information contained therein. Reproduction, use or disclosure to third parties without express authority is strictly forbidden. © Copyright 2013 ABB

Prepared by, date C Blanksvärd, 050316	Responsible department ATMA/RO/RMA	Description ACC Circuit Diagram 	Sheet 500
Approved by, date M Thunell, 050330	Take over department		No. of sh. 953
Status Approved		Document No. 3HAC17669-2	Rev. ind. 03

We reserve all rights in this document and in the information contained therein. Reproduction, use or disclosure to third parties without express authority is strictly forbidden. © Copyright 2005 ABB

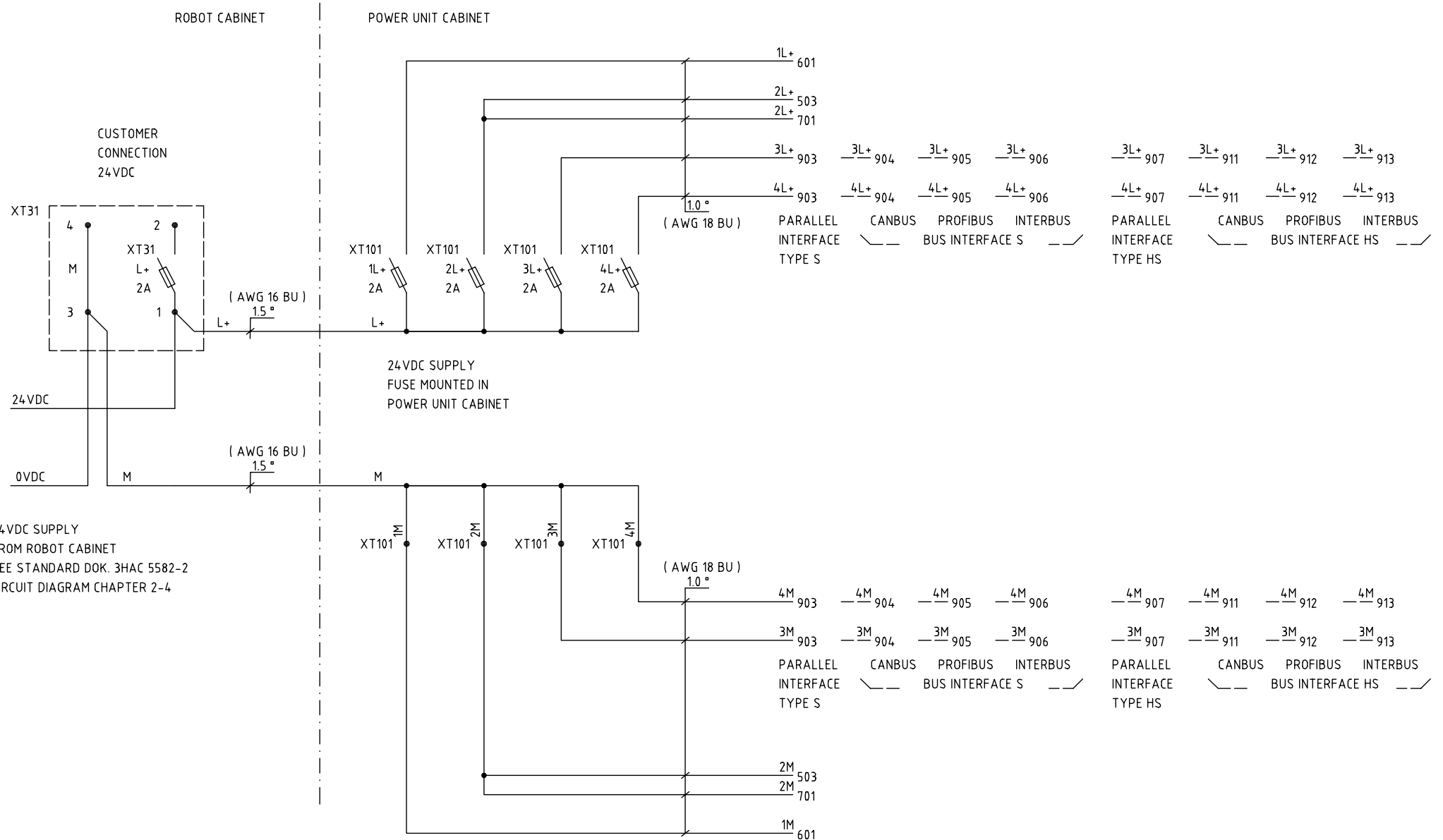

24VDC SUPPLY
 FROM ROBOT CABINET
 SEE STANDARD DOK. 3HAC 5582-2
 CIRCUIT DIAGRAM CHAPTER 2-4

24VDC SUPPLY
 FUSE MOUNTED IN
 POWER UNIT CABINET

Prepared by, date C Blanksvård, 050318	Responsible department ATMA/RO/AB	Description ACC SpotPack for pneum. gun SpotPack för pneum.fång	Circuit Diagram
Approved by, date M Thunell, 050330	Take over department		
Status Approved		Document No. 3HAC17669-2	Sheet 501 No. of sh. 977 Rev. ind. 03

POWER UNIT
 POWER SUPPLY 24VDC
 IRB 6600/6650/7600

Latest Revision

ABB ABB Automation Technologies AB

We reserve all rights in this document and in the information contained therein. Reproduction, use or disclosure to third parties without express authority is strictly forbidden. © Copyright 2015 ABB

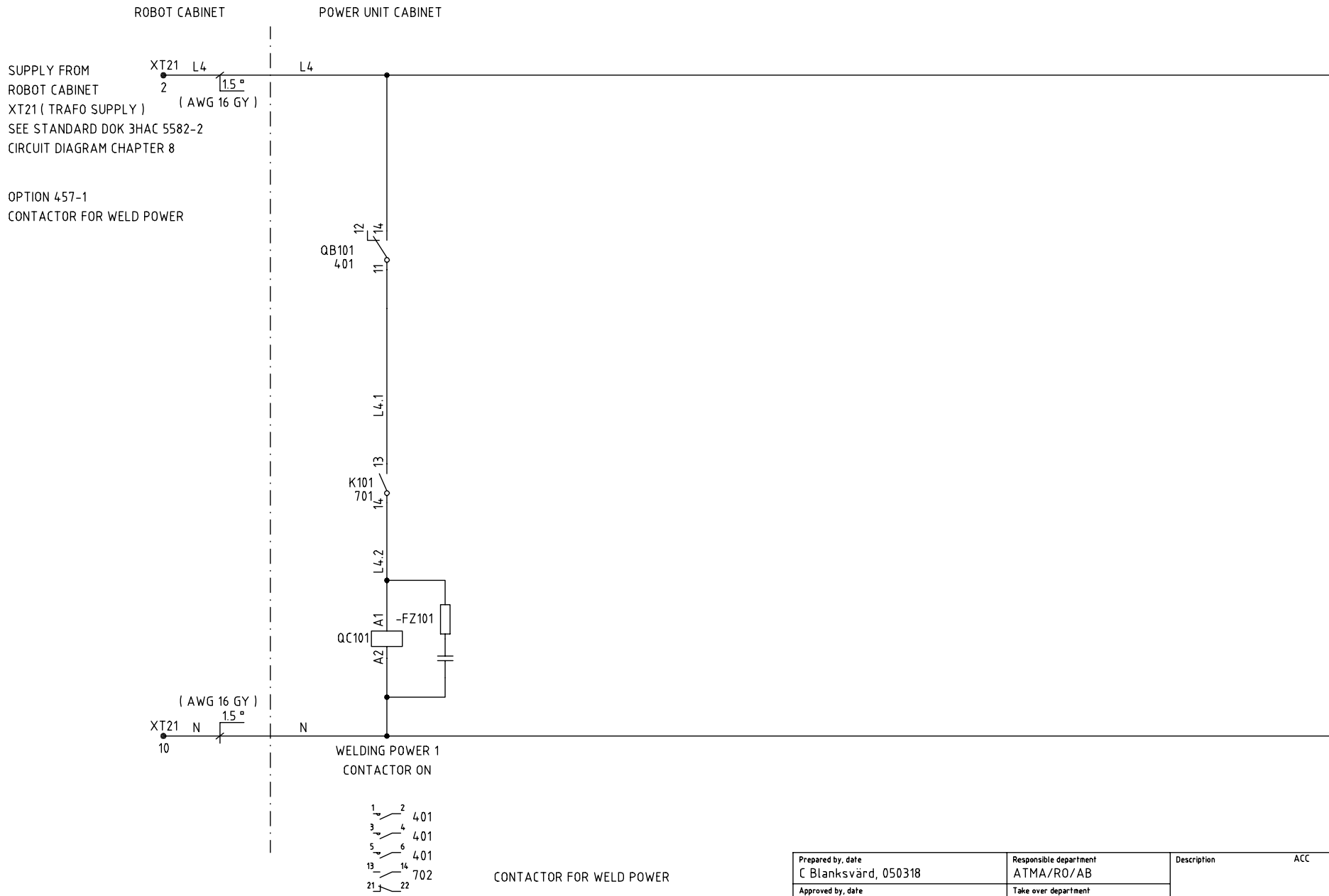

POWER UNIT
 CONTROL CIRCUIT WELDING CONTACTORS
 IRB 6600/6650/7600

Latest Revision

Prepared by, date C Blanksvård, 050318	Responsible department ATMA/RO/AB	Description ACC SpotPack for pneum. gun SpotPack för pneum.fång	Circuit Diagram
Approved by, date M Thunell, 050330	Take over department		
Status Approved		Document No. 3HAC17669-2	Sheet 502 No. of sh. 977 Rev. ind. 03

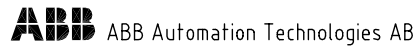

STANDARD
CONNECTION CIRCUIT SAFETY

OPTION 457-1
CONTACTOR FOR WELD POWER
CONNECTION CIRCUIT SAFETY

501 2L+

2L+

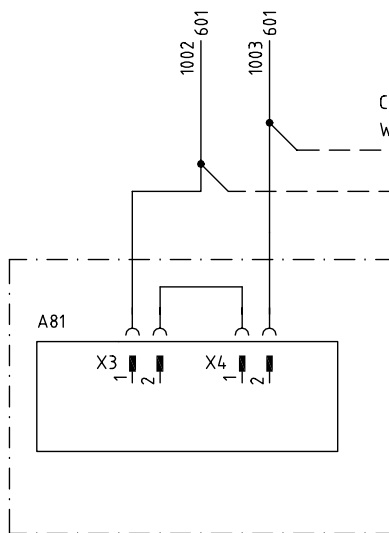

ROBOT CABINET
SEE STANDARD DOK 3HAC 5582-2
CIRCUIT DIAGRAM CHAPTER 4

CONNECTION IF OPTION
WELDING CONTACTOR USED

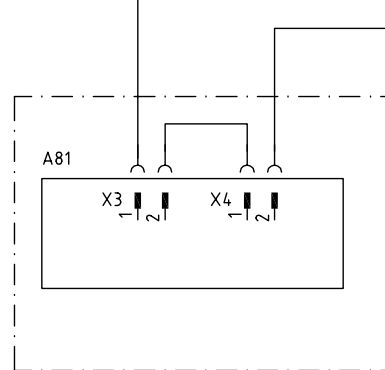
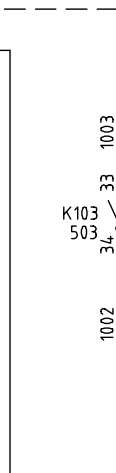

ROBOT CABINET
SEE STANDARD DOK 3HAC 5582-2
CIRCUIT DIAGRAM CHAPTER 4

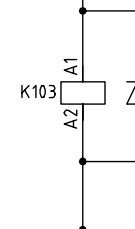

INTERLOCK WELDING

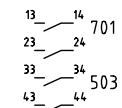

501 2M

2M

POWER UNIT
CONTROL CIRCUIT SAFETY
IRB 6600/6650/7600

Latest Revision

Prepared by, date C Blanksvärd, 050318	Responsible department ATMA/RO/AB	Description ACC SpotPack for pneum. gun SpotPack för pneum.fång	Circuit Diagram
Approved by, date M Thunell, 050330	Take over department		
Status Approved	Document No. 3HAC17669-2		Sheet 503 No. of sh. 977 Rev. ind. 03

ABB ABB Automation Technologies AB

3HAC17669-2

Rev. ind.

03

We reserve all rights in this document and in the information contained therein. Reproduction, use or disclosure to third parties without express authority is strictly forbidden. © Copyright 2003 ABB

1 2 3 4 5 6

A

6 CONTROL CIRCUIT PROCESS EQUIPMENT

SHEET CONTENTS

601 CONTROL CIRCUIT BOSCH 6000

B

C

D

No reserve all rights in this document and in the information contained therein. Reproduction, use or disclosure to third parties without express authority is strictly forbidden. © Copyright 2003 ABB

IRB 6600/6650/7600

Latest Revision

Prepared by, date C Blanksvärd, 050316	Responsible department ATMA/R0/AB	Description ACC SpotPack for pneum. gun SpotPack för pneum.fång	Circuit Diagram 
Approved by, date M Thunell, 050330	Take over department		
Status Approved			Sheet 600
		Document No. 3HAC17669-2	No. of sh. 953
			Rev. ind. 03

1 2 3 4 5 6

We reserve all rights in this document and in the information contained therein. Reproduction, use or disclosure to third parties without express authority is strictly forbidden. © Copyright 2005 ABB

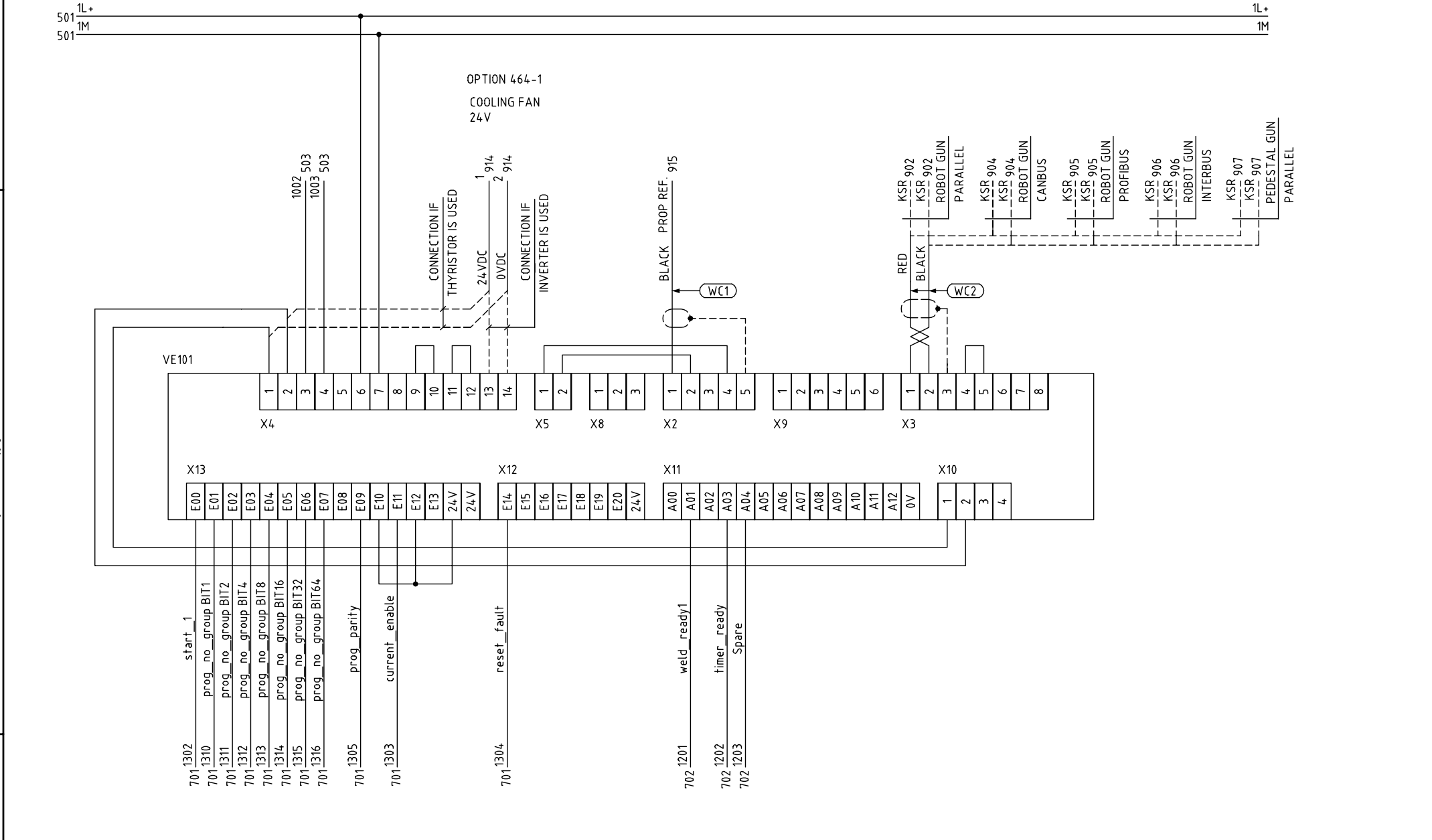

POWER UNIT CONTROL CIRCUIT BOSCH 6000 IRB 6600/6650/7600	Latest Revision	Prepared by, date C Blanksvård, 050318	Responsible department ATMA/RO/AB	Description ACC SpotPack for pneum. gun SpotPack för pneum.fång	Circuit Diagram
		Approved by, date M Thunell, 050330	Take over department		
		Status Approved		Document No. 3HAC17669-2	No. of sh. 977
		ABB ABB Automation Technologies AB			Rev. ind. 03

A

7 I/O UNIT
 SHEET CONTENTS
 701 DIGITAL I/O UNIT 01 OUTPUT
 702 DIGITAL I/O UNIT 01 INPUT

B

C

D

We reserve all rights in this document and in the information contained therein. Reproduction, use or disclosure to third parties without express authority is strictly forbidden. © Copyright 2003 ABB

IRB 6600/6650/7600

Latest Revision

Prepared by, date C Blanksvärd, 050316	Responsible department ATMA/R0/AB	Description ACC SpotPack for pneum. gun SpotPack för pneum.fång	Circuit Diagram 
Approved by, date M Thunell, 050330	Take over department		
Status Approved	Document No. 3HAC17669-2		Sheet 700 No. of sh. 953 Rev. ind. 03

We reserve all rights in this document and in the information contained therein. Reproduction, use or disclosure to third parties without express authority is strictly forbidden. © Copyright 2015 ABB

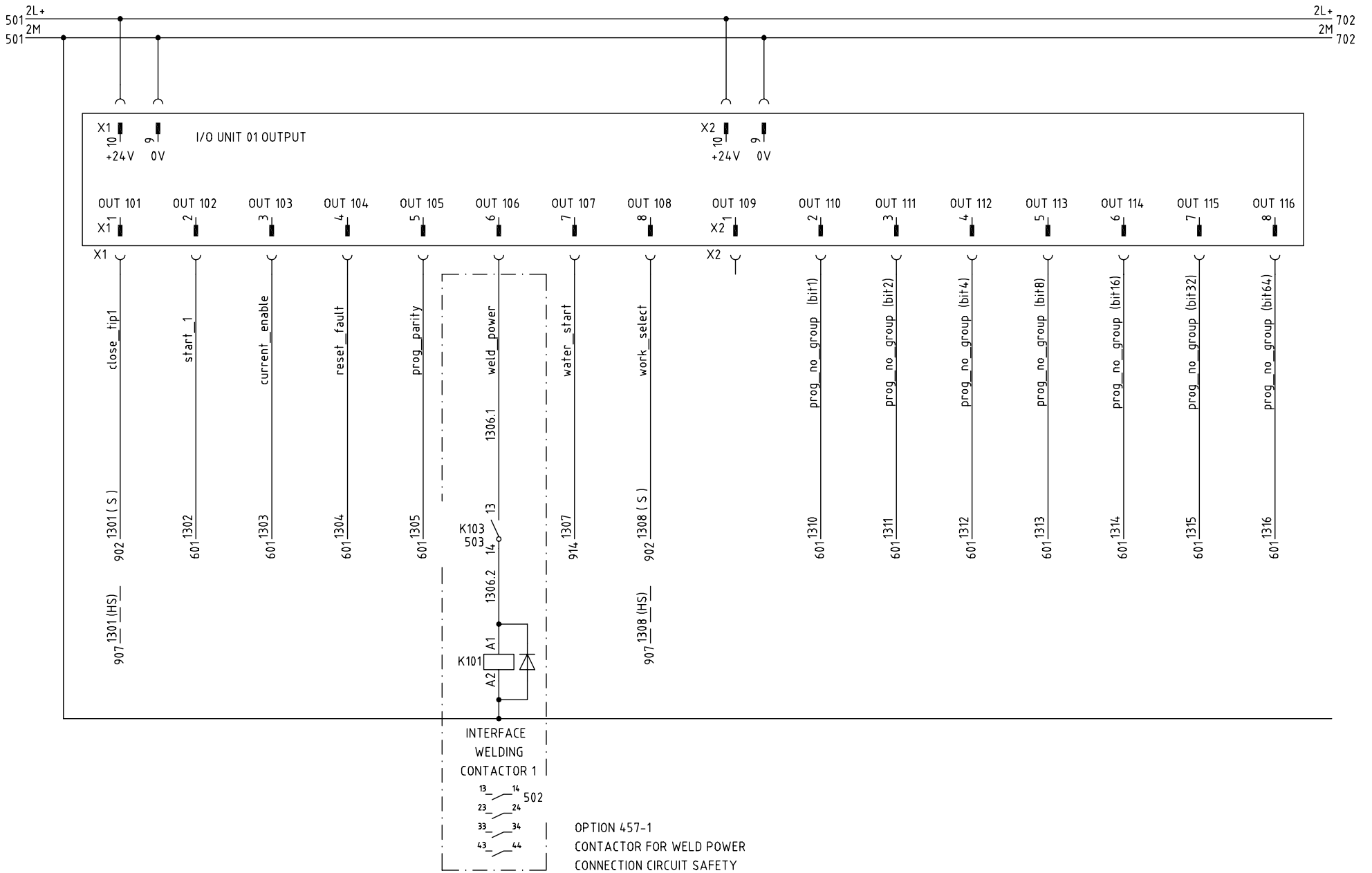

POWER UNIT
 DIGITAL I/O UNIT 01 OUTPUT
 IRB 6600/6650/7600

Latest Revision

Prepared by, date C Blanksvärd, 050318	Responsible department ATMA/R0/AB	Description ACC SpotPack for pneum. gun SpotPack för pneum.fång	Circuit Diagram
Approved by, date M Thunell, 050330	Take over department		
Status Approved	Document No. 3HAC17669-2		No. of sh. 701 977 Rev. ind. 03

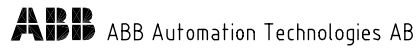

We reserve all rights in this document and in the information contained therein. Reproduction, use or disclosure to third parties without express authority is strictly forbidden. © Copyright 2005 ABB

A

B

C

D

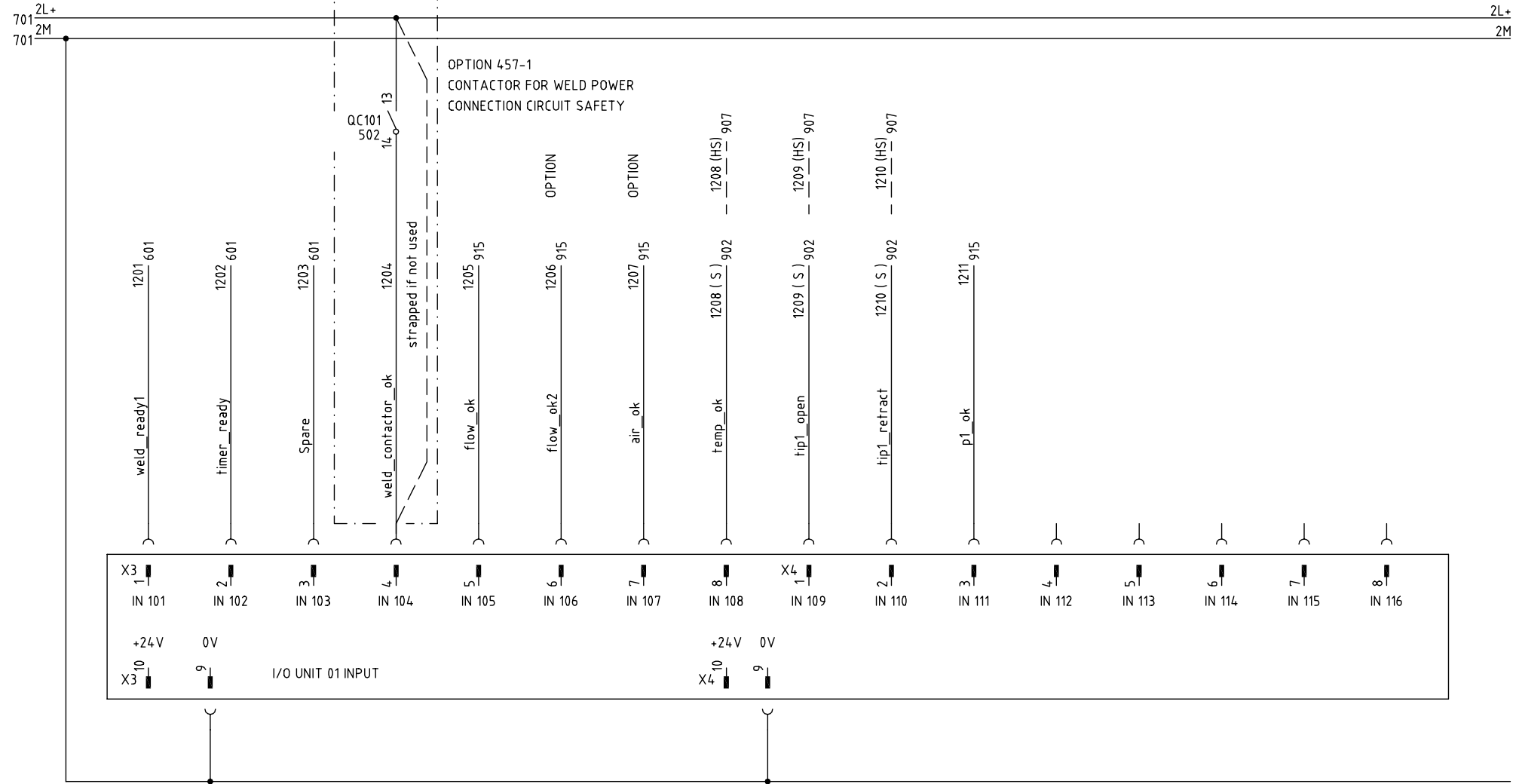

POWER UNIT
 DIGITAL I/O 01 UNIT
 IRB 6600/6650/7600

Latest Revision

Prepared by, date C Blanksvård, 050318	Responsible department ATMA/RO/AB	Description ACC SpotPack for pneum. gun SpotPack för pneum.fång	Circuit Diagram
Approved by, date M Thunell, 050330	Take over department		
Status Approved		Document No. 3HAC17669-2	No. of sh. 977
			Rev. ind. 03

9	CABLES AND EXTERNAL CONNECTIONS
SHEET	CONTENTS
901	WELD POWER, TYPE S/HS
902	CUSTOMER SIGNALS PARALLEL, TYPE S
903	CUSTOMER POWER PARALLEL, TYPE S
904	CUSTOMER POWER/CUSTOMER BUS, CANBUS, TYPE S
905	CUSTOMER POWER/CUSTOMER BUS, PROFIBUS, TYPE S
906	CUSTOMER POWER/CUSTOMER BUS, INTERBUS, TYPE S
907	CUSTOMER POWER/CUSTOMER SIGNALS, PEDESTAL GUN 1, PARALLEL, TYPE HS
908	CUSTOMER SIGNALS PARALLEL, TYPE HS
909	CUSTOMER POWER PARALLEL, TYPE HS
910	CUSTOMER POWER/CUSTOMER SIGNALS BASIC PARALLEL COMMUNICATION, TYPE HS
911	CUSTOMER POWER/CUSTOMER BUS, CANBUS, TYPE HS
912	CUSTOMER POWER/CUSTOMER BUS, PROFIBUS, TYPE HS
913	CUSTOMER POWER/CUSTOMER BUS, INTERBUS, TYPE HS
914	CUSTOMER POWER, FAN UNIT
915	CUSTOMER POWER/CUSTOMER SIGNALS TO WATER AND AIR UNIT
950	DESIGN CHANGES, NOT 1.1,1.2
951	DESIGN CHANGES, NOT 1.3,1.4
952	DESIGN CHANGES, NOT 1.5,1.6
953	DESIGN CHANGES, NOT 1.7,1.8
954	DESIGN CHANGES, NOT 1.9,1.10
955	DESIGN CHANGES, NOT 1.11
970	LOWER ARM HARNESS: 3HAC020126-001, 3HAC020304-001
971	LOWER ARM HARNESS: 3HAC16782-1, 3HAC16783-1, 3HAC16788-1, 3HAC16789-1
972	LOWER ARM HARNESS: 3HAC020447-001
973	LOWER ARM HARNESS: 3HAC020179-001, 3HAC020303-001
974	UPPER ARM HARNESS: 3HAC16643-1,-2,-3, 3HAC16645-1,-2,-3, 3HAC16647-1-5
975	UPPER ARM HARNESS: 3HAC16644-1,-2,-3, 3HAC16646-1,-2,-3, 3HAC16648-1-5
976	LOWER ARM HARNESS: 3HAC16780-1, 3HAC16781-1, 3HAC16786-1, 3HAC16787-1
977	LOWER ARM HARNESS: 3HAC16784-1, 3HAC16785-1, 3HAC16790-1, 3HAC16791-1

We reserve all rights in this document and in the information contained therein. Reproduction, use or disclosure to third parties without express authority is strictly forbidden. © Copyright 2003 ABB

Prepared by, date C Blanksvärd, 050316	Responsible department ATMA/R0/AB	Description ACC Circuit Diagram 	Sheet 900
Approved by, date M Thunell, 050330	Take over department		No. of sh. 977
Status Approved		Document No. 3HAC17669-2	Rev. ind. 03

FLOOR HARNESS
3HAC16847-1,-2

POWER UNIT CABINET

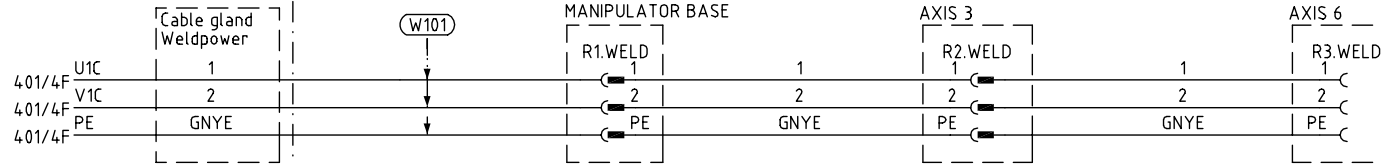

WELD POWER 1 ROBOT MOUNTED GUN
TYPE S

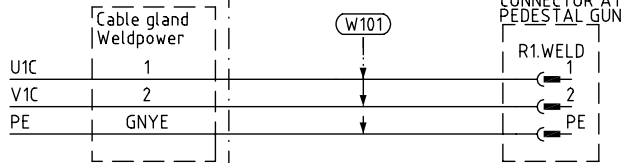

WELD POWER 1 PEDESTAL MOUNTED GUN
TYPE HS

CABLES AND EXTERNAL CONNECTIONS

IRB 6600/6650/7600

Latest Revision

Prepared by, date C Blanksvärd, 050316	Responsible department ATMA/RO/AB	Description ACC SpotPack for pneum. gun SpotPack för pneum.fång	Circuit Diagram
Approved by, date M Thunell, 050330	Take over department		
Status Approved		Document No. 3HAC17669-2	Sheet 901 No. of sh. 977 Rev. ind. 03

ABB ABB Automation Technologies AB

TYPE S
CUSTOMER SIGNALS
PARALLEL COMMUNICATION

VALID FOR HARNESS IN CABINET
3HAC17209-1
AND FLOOR HARNESS
3HAC17147-1, -2, -3, -6
LOWER ARM HARNESS
3HAC16780-1
3HAC16781-1
3HAC16786-1
3HAC16787-1
UPPER ARM HARNESS
3HAC16643-1, -2, -3
3HAC16645-1, -2, -3

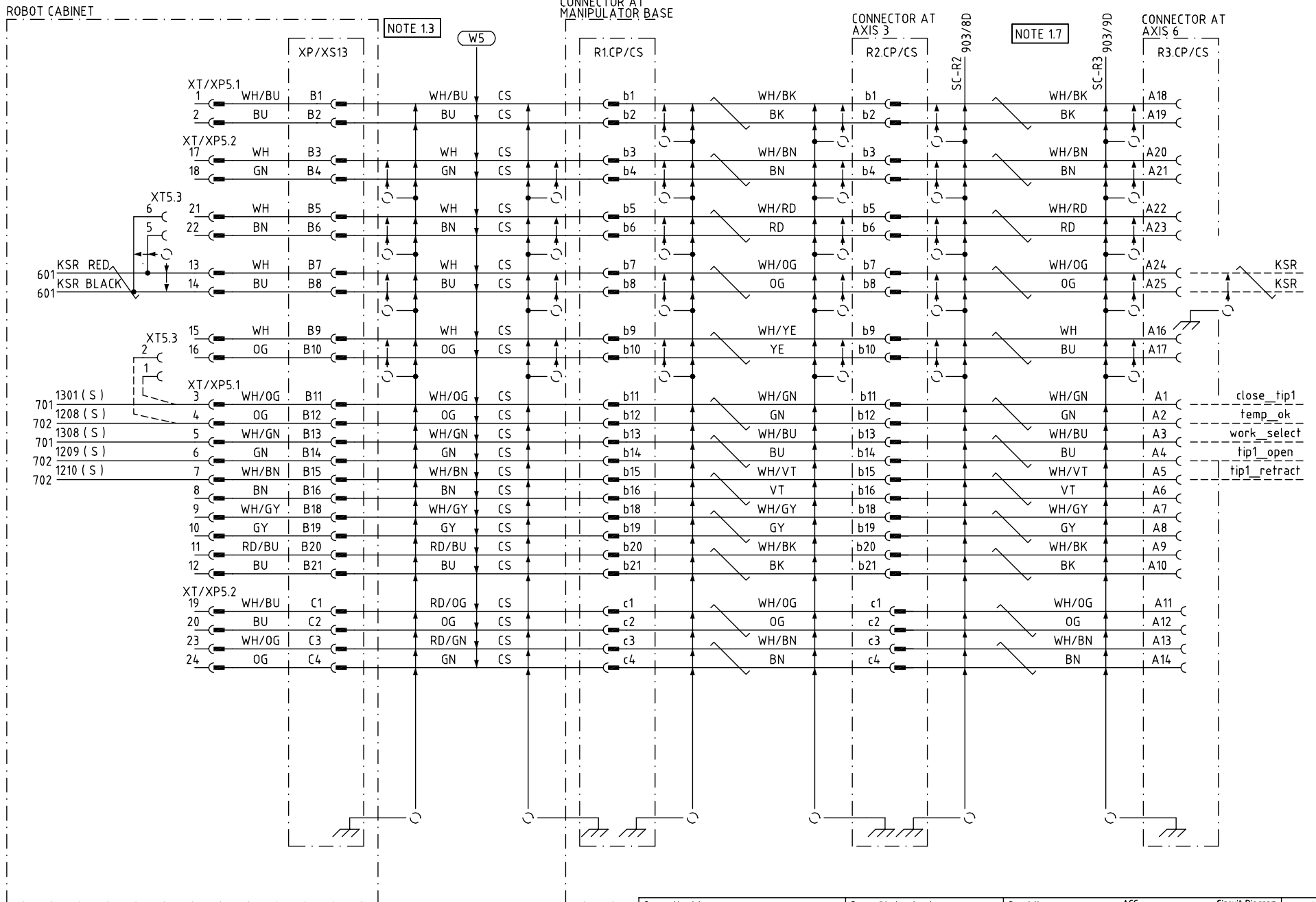

CABLES AND EXTERNAL CONNECTIONS
IRB 6600/6650/7600

Latest Revision

Prepared by, date C Blanksvård, 050318	Responsible department ATMA/R0/AB	Description ACC SpotPack for pneum. gun SpotPack för pneum.fång	Circuit Diagram
Approved by, date M Thunell, 050330	Take over department		
Status Approved		Document No. 3HAC17669-2	Sheet 902 No. of sh. 977 Rev. ind. 03

ABB ABB Automation Technologies AB

TYPE S
CUSTOMER POWER
PARALLEL COMMUNICATION

VALID FOR
HARNESS IN CABINET
3HAC17209-1
AND
FLOOR HARNESS
3HAC17147-1, -2, -3, -6
LOWER ARM HARNESS
3HAC16780-1
3HAC16781-1
3HAC16786-1
3HAC16787-1
UPPER ARM HARNESS
3HAC16643-1, -2, -3
3HAC16645-1, -2, -3

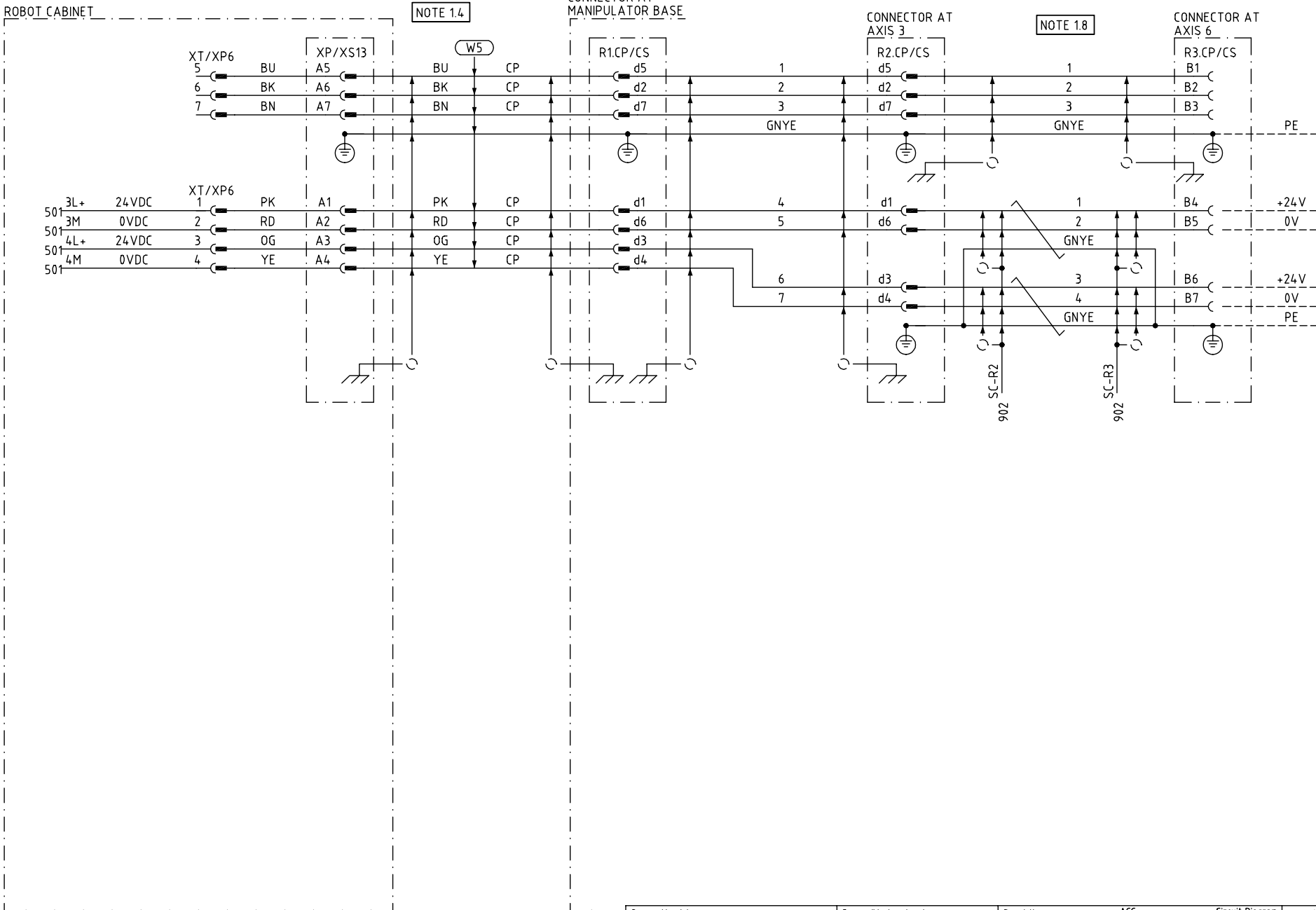

We reserve all rights in this document and in the information contained therein. Reproduction, use or disclosure to third parties without express authority is strictly forbidden. © Copyright 2005 ABB

CABLES AND EXTERNAL CONNECTIONS
IRB 6600/6650/7600

Latest Revision

Prepared by, date C Blanksvärd, 050318	Responsible department ATMA/RO/AB	Description ACC SpotPack for pneum. gun SpotPack för pneum.fång	Circuit Diagram
Approved by, date M Thunell, 050330	Take over department		
Status Approved		Document No. 3HAC17669-2	Sheet 903 No. of sh. 977 Rev. ind. 03

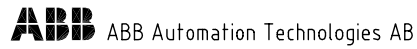

TYPE S
 CUSTOMER POWER/
 CUSTOMER BUS
 CANBUS
 COMMUNICATION

VALID FOR
 HARNESS IN CABINET
 3HAC16904-1
 AND
 FLOOR HARNESS
 3HAC14890-1,-4,-6,-7
 LOWER ARM HARNESS
 3HAC16784-1
 3HAC16785-1
 3HAC16790-1
 3HAC16791-1
 UPPER ARM HARNESS
 3HAC16644-1,-2,-3
 3HAC16646-1,-2,-3

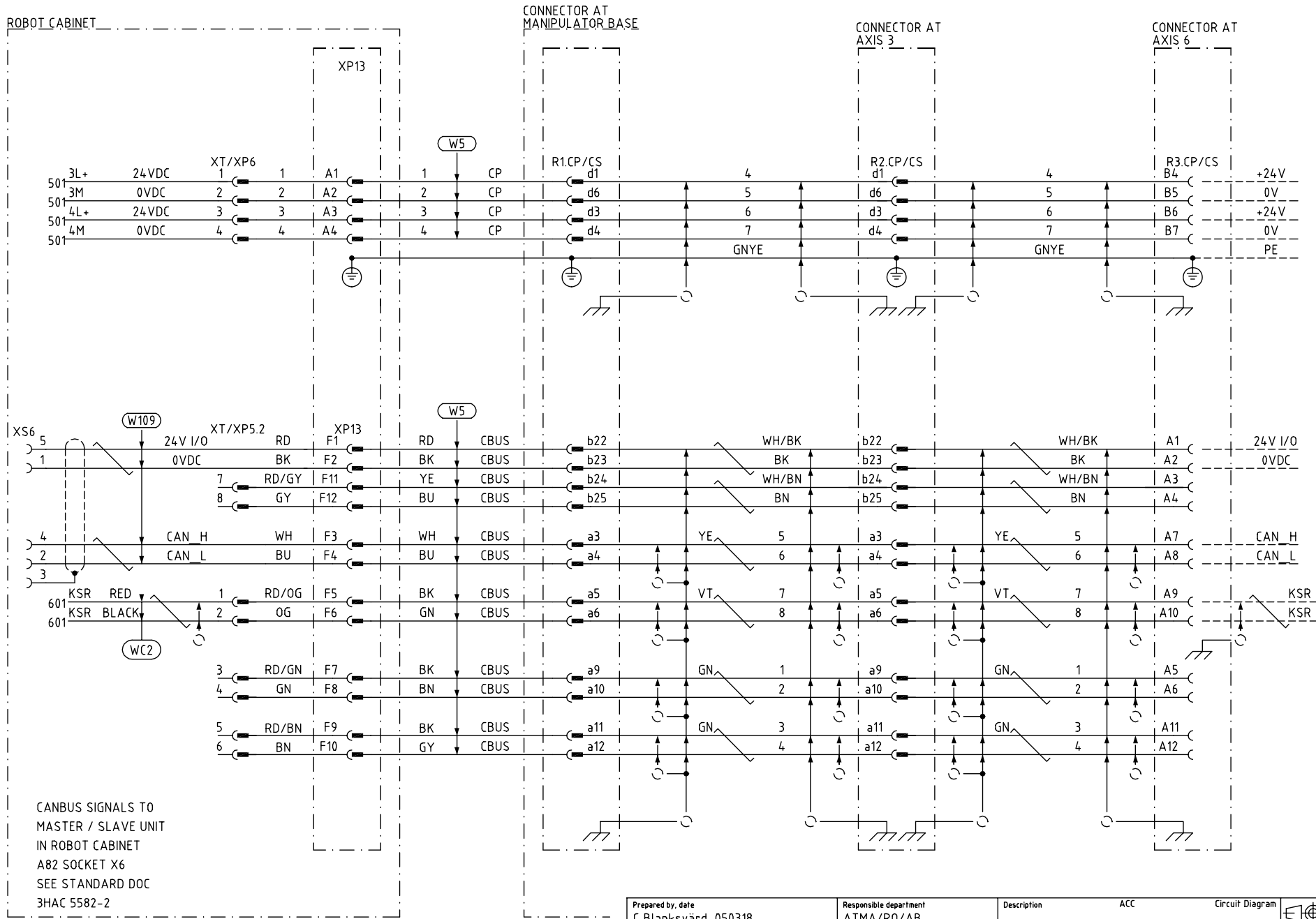

CANBUS SIGNALS TO
 MASTER / SLAVE UNIT
 IN ROBOT CABINET
 A82 SOCKET X6
 SEE STANDARD DOC
 3HAC 5582-2

CABLES AND EXTERNAL CONNECTIONS
 IRB 6600/6650/7600

Latest Revision

Prepared by, date C Blanksvård, 050318	Responsible department ATMA/RO/AB	Description ACC	Circuit Diagram
Approved by, date M Thunell, 050330	Take over department	SpotPack for pneum. gun SpotPack för pneum.fång	Sheet 904
Status Approved			No. of sh. 977
ABB ABB Automation Technologies AB		Document No. 3HAC17669-2	Rev. ind. 03

We reserve all rights in this document and in the information contained therein. Reproduction, use or disclosure to third parties without express authority is strictly forbidden. © Copyright 2003 ABB

TYPE S

CUSTOMER POWER/
CUSTOMER BUS

PROFIBUS
COMMUNICATION

VALID FOR
HARNESS IN CABINET
3HAC17189-1

FLOOR HARNESS
3HAC17200-1,-4,-5,-6
LOWER ARM HARNESS
3HAC16784-1
3HAC16785-1
3HAC16790-1
3HAC16791-1
UPPER ARM HARNESS
3HAC16644-1,-2,-3
3HAC16646-1,-2,-3

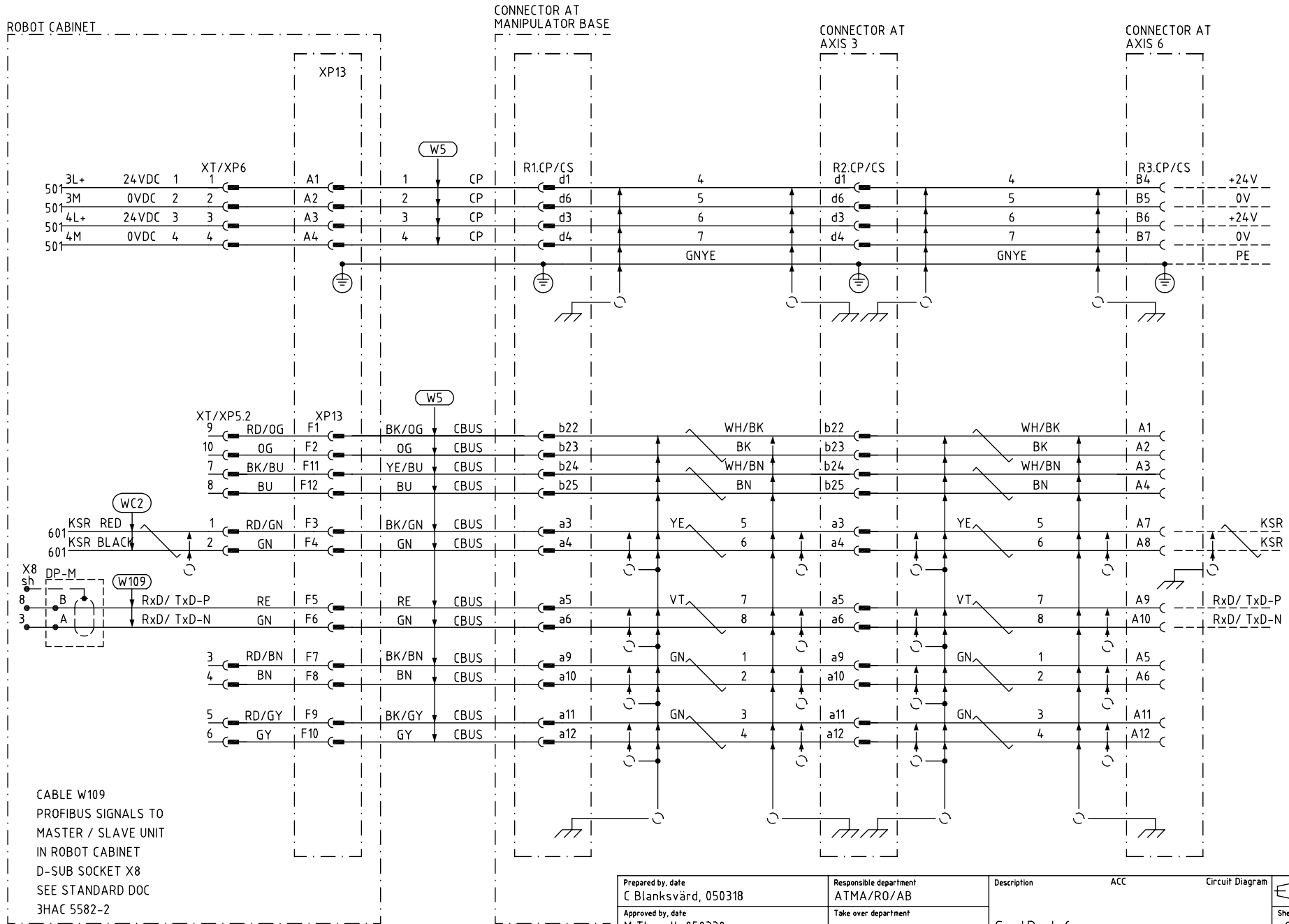

CABLE W109
PROFIBUS SIGNALS TO
MASTER / SLAVE UNIT
IN ROBOT CABINET
D-SUB SOCKET X8
SEE STANDARD DOC
3HAC 5582-2

Prepared by, date C Blanksvärd, 050318	Responsible department ATMA/RO/AB	Description ACC	Circuit Diagram
Approved by, date M Thunell, 050330	Take over department	SpotPack for pneum. gun SpotPack för pneum.fång	Sheet 905
Status Approved			No. of sh. 977
ABB ABB Automation Technologies AB		Document No. 3HAC17669-2	Rev. ind. 03

CABLES AND EXTERNAL CONNECTIONS
IRB 6600/6650/7600

Latest Revision

We reserve all rights in this document and in the information contained therein. Reproduction, use or disclosure to third parties without express authority is strictly forbidden. © Copyright 2005 ABB

TYPE S
CUSTOMER POWER/
CUSTOMER BUS

INTERBUS
COMMUNICATION

VALID FOR
HARNESS IN CABINET
3HAC16905-1
AND
FLOOR HARNESS
3HAC15644-1,-4,-5,-6
LOWER ARM HARNESS
3HAC16784-1
3HAC16785-1
3HAC16790-1
3HAC16791-1
UPPER ARM HARNESS
3HAC16644-1,-2,-3
3HAC16646-1,-2,-3

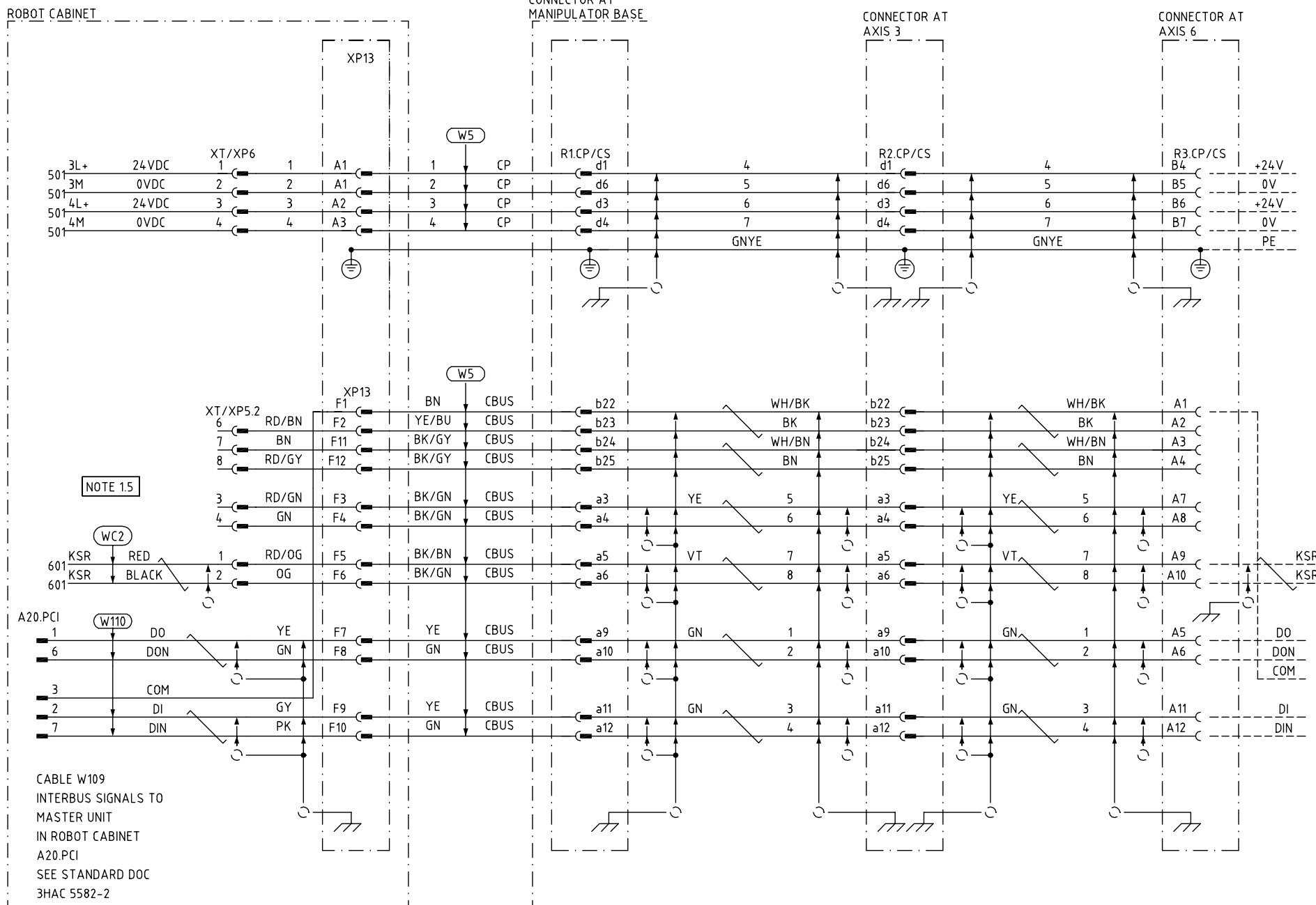

NOTE 1.5

CABLE W109
INTERBUS SIGNALS TO
MASTER UNIT
IN ROBOT CABINET
A20.PCI
SEE STANDARD DOC
3HAC 5582-2

Prepared by, date C Blanksvård, 050318	Responsible department ATMA/RO/AB	Description ACC	Circuit Diagram
Approved by, date M Thunell, 050330	Take over department	SpotPack for pneum. gun SpotPack för pneum.fång	Sheet 906
Status Approved		Document No. 3HAC17669-2	No. of sh. 977
			Rev. ind. 03

CABLES AND EXTERNAL CONNECTIONS
IRB 6600/6650/7600

Latest Revision

ABB ABB Automation Technologies AB

TYPE HS
CUSTOMER POWER/
CUSTOMER SIGNALS,
PEDESTAL GUN 1,
PARALLEL, TYPE HS

PARALLEL
INTERFACE

FLOOR HARNESS
3HAC16873-1,-2,-3

POWER UNIT CABINET

PEDESTAL GUN 1

TO WELDING
TIMER

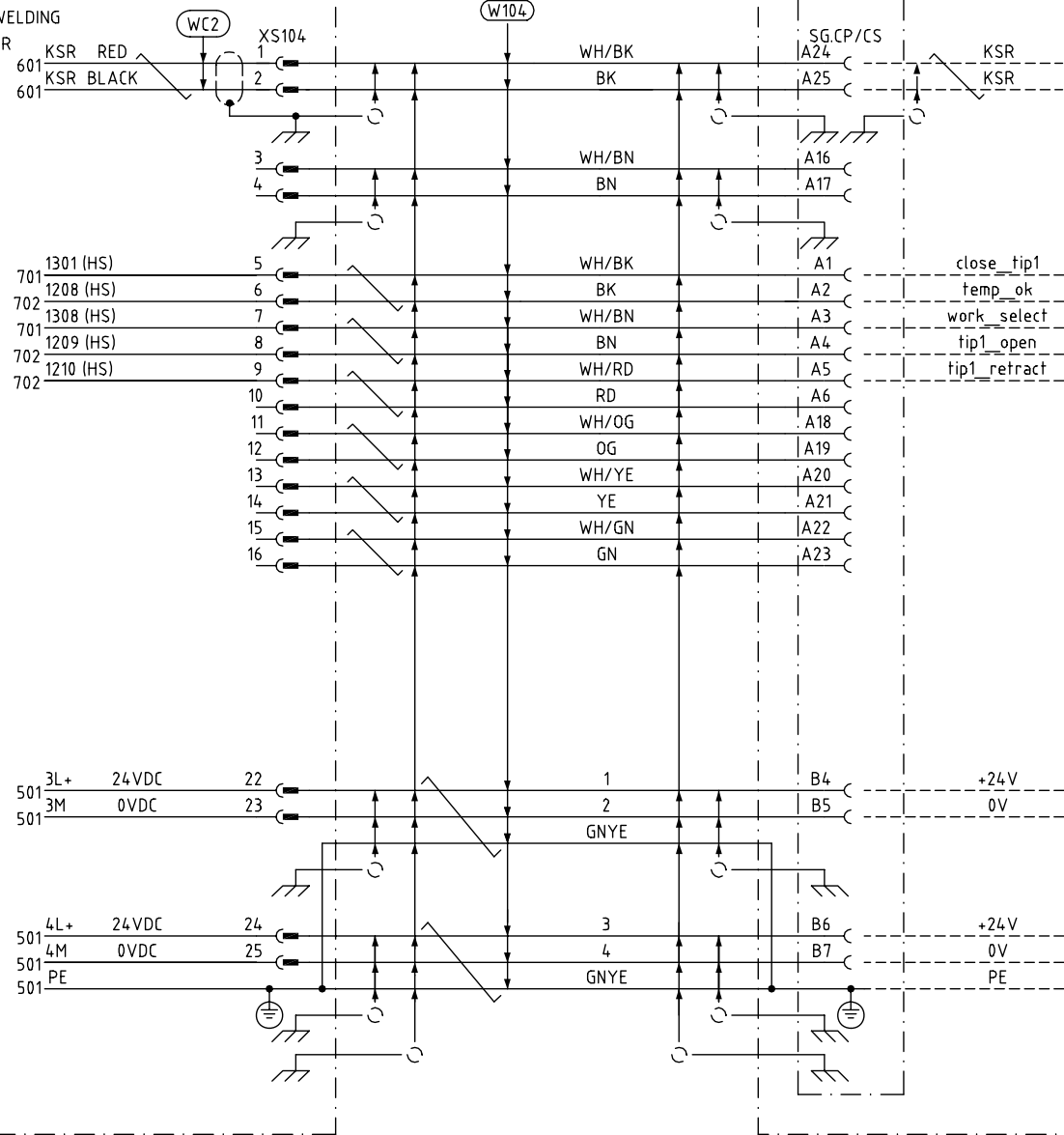

We reserve all rights in this document and in the information contained therein. Reproduction, use or disclosure to third parties without express authority is strictly forbidden. © Copyright 2005 ABB

CABLES AND EXTERNAL CONNECTIONS
IRB 6600/6650/7600

Latest Revision

Prepared by, date C Blanksvård, 050318	Responsible department ATMA/RO/AB	Description ACC SpotPack for pneum. gun SpotPack för pneum.fång	Circuit Diagram
Approved by, date M Thunell, 050330	Take over department		
Status Approved		Document No. 3HAC17669-2	Sheet 907 No. of sh. 977 Rev. ind. 03

ABB ABB Automation Technologies AB

TYPE HS

CUSTOMER POWER

PARALLEL COMMUNICATION

VALID FOR HARNESS IN CABINET
 3HAC17209-1
 AND
 FLOOR HARNESS
 3HAC17147-1, -2, -3, -6
 LOWER ARM HARNESS
 3HAC020126-001
 3HAC020304-001
 UPPER ARM HARNESS
 3HAC16647-1, -2, -3, -4, -5

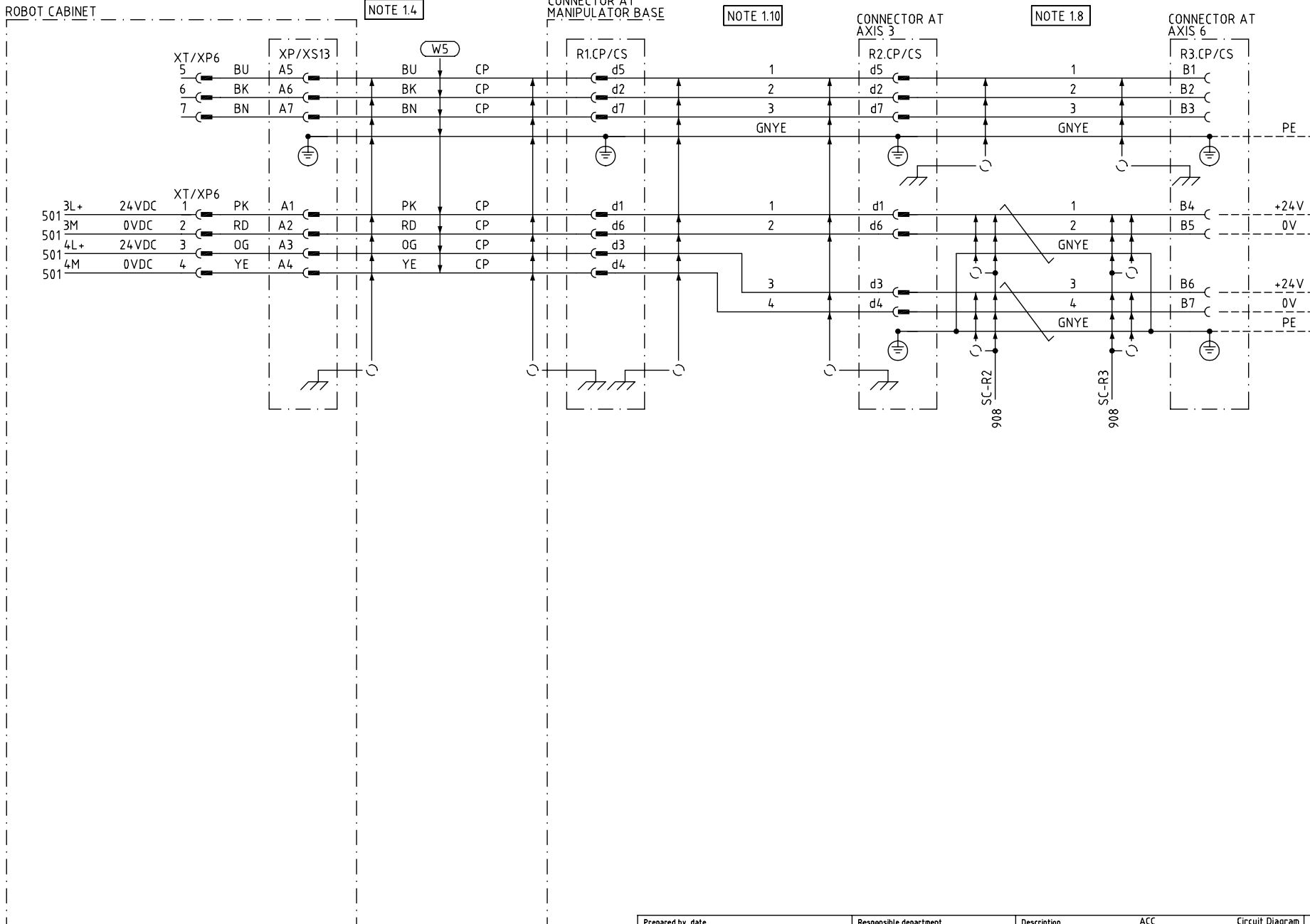

We reserve all rights in this document and in the information contained therein. Reproduction, use or disclosure to third parties without express authority is strictly forbidden. © Copyright 2003 ABB

CABLES AND EXTERNAL CONNECTIONS

IRB 6600/6650/7600

Latest Revision

Prepared by, date C Blanksvärd, 050318	Responsible department ATMA/R0/AB	Description ACC SpotPack for pneum. gun SpotPack för pneum.fång	Circuit Diagram
Approved by, date M Thunell, 050330	Take over department		
Status Approved		Document No. 3HAC17669-2	Sheet 909 No. of sh. 977 Rev. ind. 03

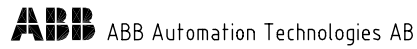

TYPE HS
CUSTOMER SIGNALS
BASIC
PARALLEL
COMMUNICATION

VALID FOR
HARNESS IN CABINET
3HAC17209-1
AND
FLOOR HARNESS
3HAC17147-1, -2, -3, -6
LOWER ARM HARNESS
3HAC020303-001
3HAC020179-001
UPPER ARM HARNESS
3HAC16647-1, -2, -3, -4, -5

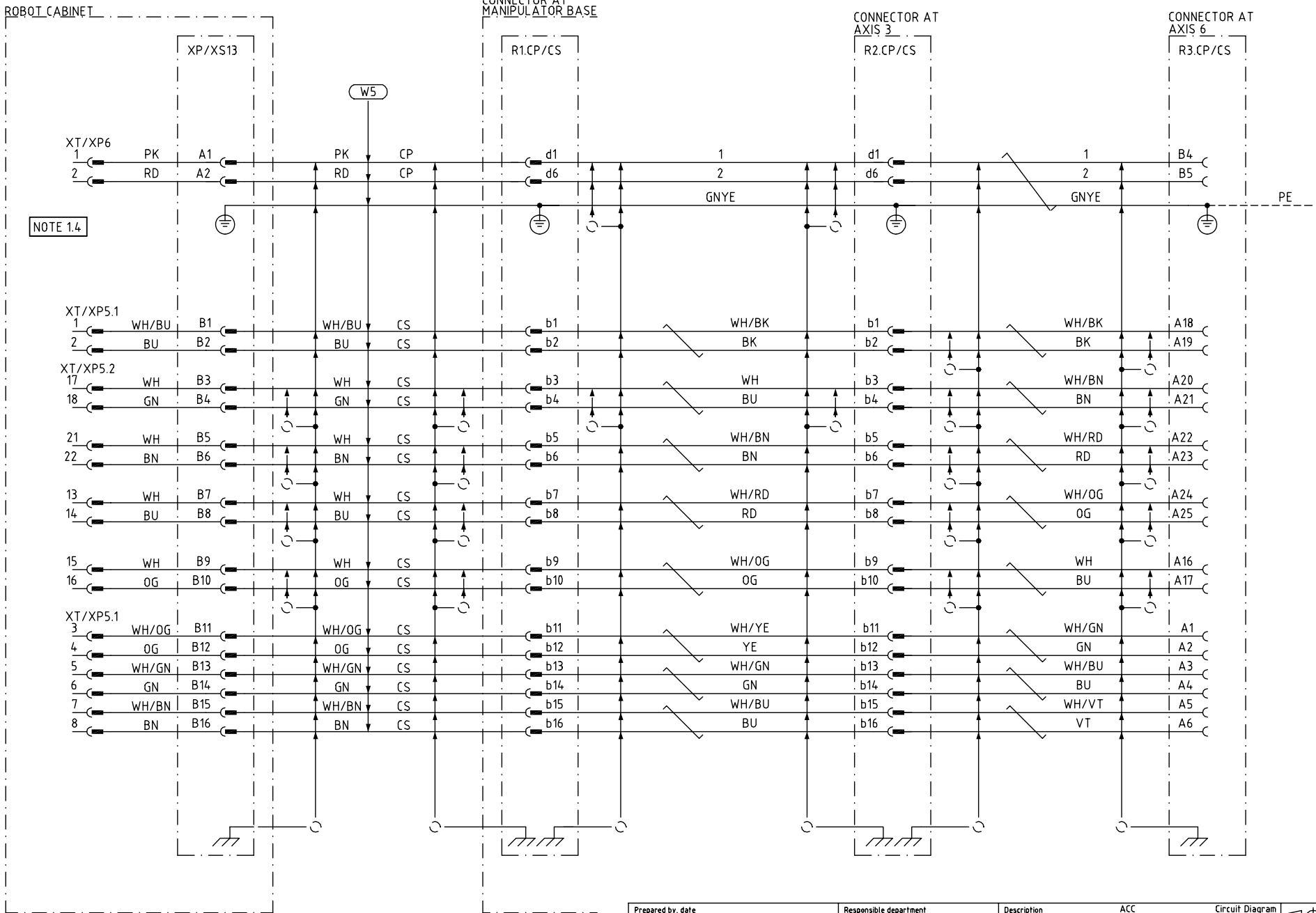

NOTE 1.4

We reserve all rights in this document and in the information contained therein. Reproduction, use or disclosure to third parties without express authority is strictly forbidden. © Copyright 2003 ABB

CABLES AND EXTERNAL CONNECTIONS
IRB 6600/6650/7600

Latest Revision

Prepared by, date C Blanksvård, 050316	Responsible department ATMA/R0/AB	Description ACC SpotPack for pneum. gun SpotPack för pneum.fång	Circuit Diagram
Approved by, date M Thunell, 050330	Take over department		
Status Approved	Document No. 3HAC17669-2		Sheet 910 No. of sh. 977 Rev. ind. 03

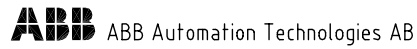

TYPE HS
 CUSTOMER POWER/
 CUSTOMER BUS
 CANBUS
 COMMUNICATION

VALID FOR
 HARNESS IN CABINET
 3HAC16904-1
 AND
 FLOOR HARNESS
 3HAC14890-1,-4,-6,-7
 LOWER ARM HARNESS
 3HAC020126-001
 3HAC020304-001
 UPPER ARM HARNESS
 3HAC16648-1,-2,-3,-4,-5

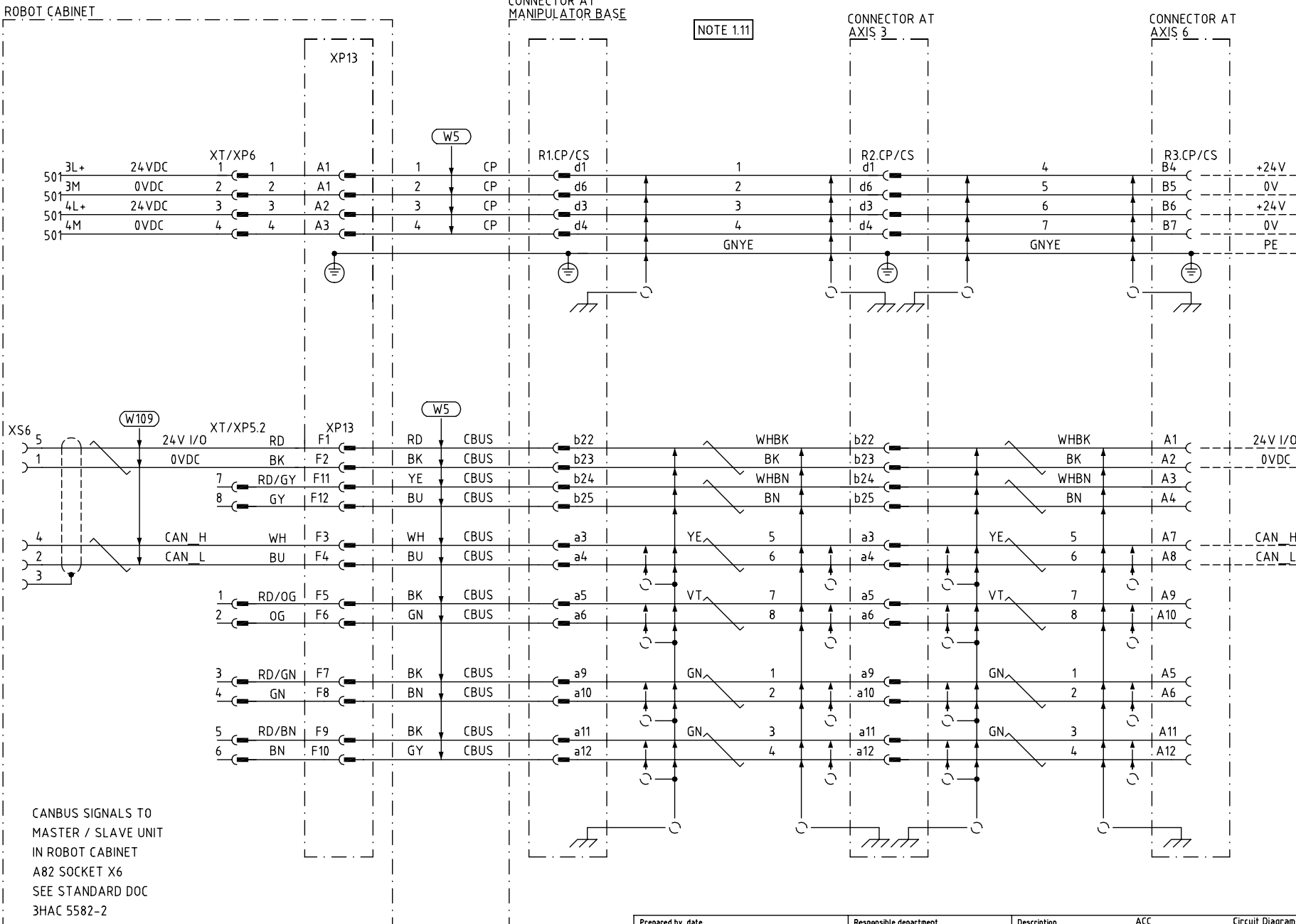

CANBUS SIGNALS TO
 MASTER / SLAVE UNIT
 IN ROBOT CABINET
 A82 SOCKET X6
 SEE STANDARD DOC
 3HAC 5582-2

CABLES AND EXTERNAL CONNECTIONS
 IRB 6600/6650/7600

Latest Revision

Prepared by, date C Blanksvård, 050318	Responsible department ATMA/RO/AB	Description ACC SpotPack for pneum. gun SpotPack för pneum.fång	Circuit Diagram
Approved by, date M Thunell, 050330	Take over department		
Status Approved		Document No. 3HAC17669-2	Sheet 911 No. of sh. 977 Rev. ind. 03

ABB ABB Automation Technologies AB

TYPE HS
CUSTOMER POWER/
CUSTOMER BUS

PROFIBUS
COMMUNICATION

VALID FOR
HARNESS IN CABINET
3HAC17189-1
AND
FLOOR HARNESS
3HAC17200-1,-4,-5,-6
LOWER ARM HARNESS
3HAC020126-001
3HAC020304-001
UPPER ARM HARNESS
3HAC16648-1,-2,-3,-4,-5

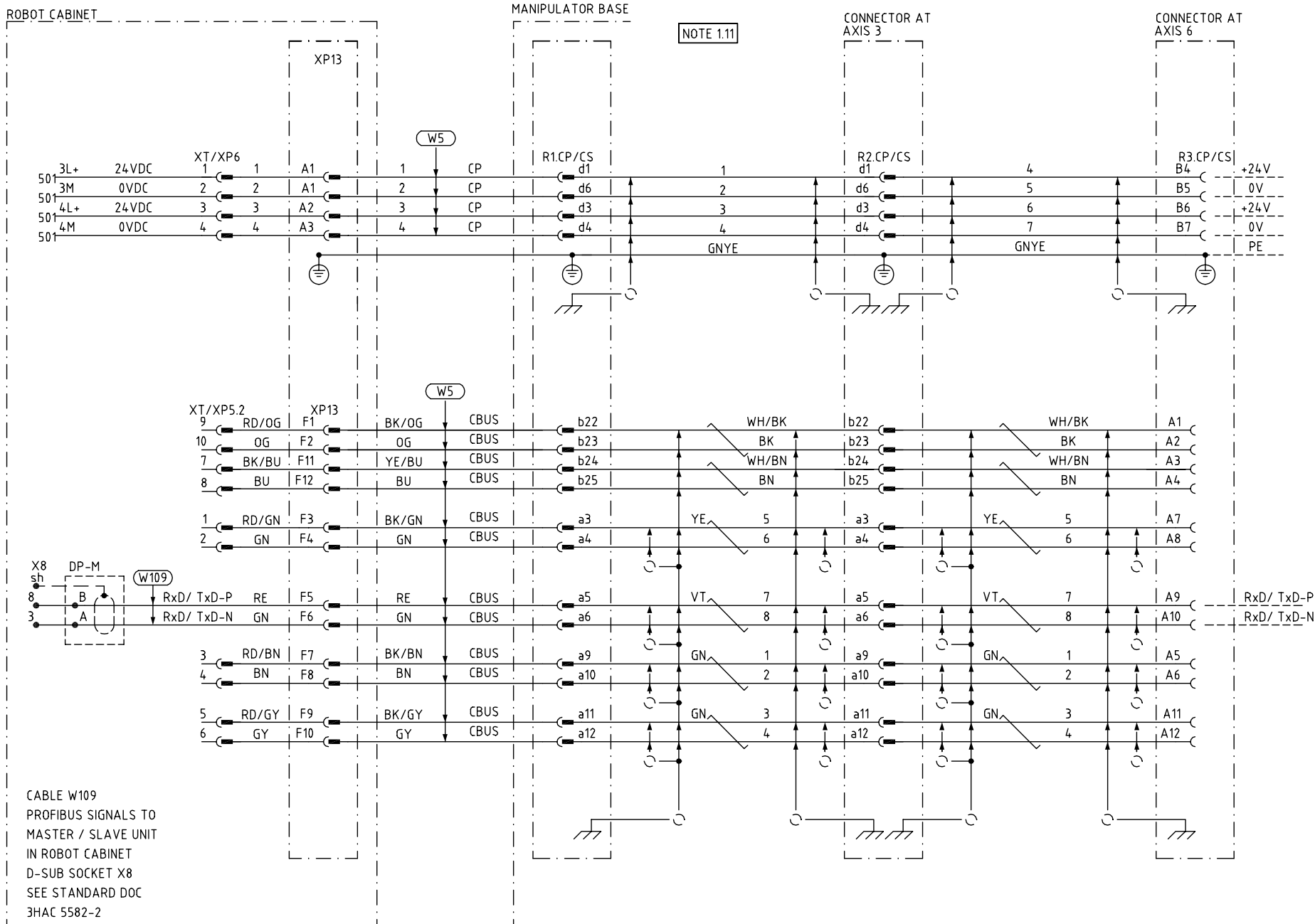

CABLE W109
PROFIBUS SIGNALS TO
MASTER / SLAVE UNIT
IN ROBOT CABINET
D-SUB SOCKET X8
SEE STANDARD DOC
3HAC 5582-2

NOTE 1.11

Prepared by, date C Blanksvård, 050318	Responsible department ATMA/RO/AB	Description ACC SpotPack for pneum. gun SpotPack för pneum.fång	Circuit Diagram
Approved by, date M Thunell, 050330	Take over department		
Status Approved		Document No. 3HAC17669-2	Sheet 912 No. of sh. 977 Rev. ind. 03

CABLES AND EXTERNAL CONNECTIONS
IRB 6600/6650/7600

Latest Revision

ABB ABB Automation Technologies AB

3HAC17669-2

03

TYPE HS

CUSTOMER POWER/
CUSTOMER BUS

INTERBUS
COMMUNICATION

VALID FOR
HARNESS IN CABINET
3HAC16905-1
AND
FLOOR HARNESS
3HAC15644-1,-4,-5,-6
LOWER ARM HARNESS
3HAC020126-001
3HAC020304-001
UPPER ARM HARNESS
3HAC16648-1,-2,-3,-4,-5

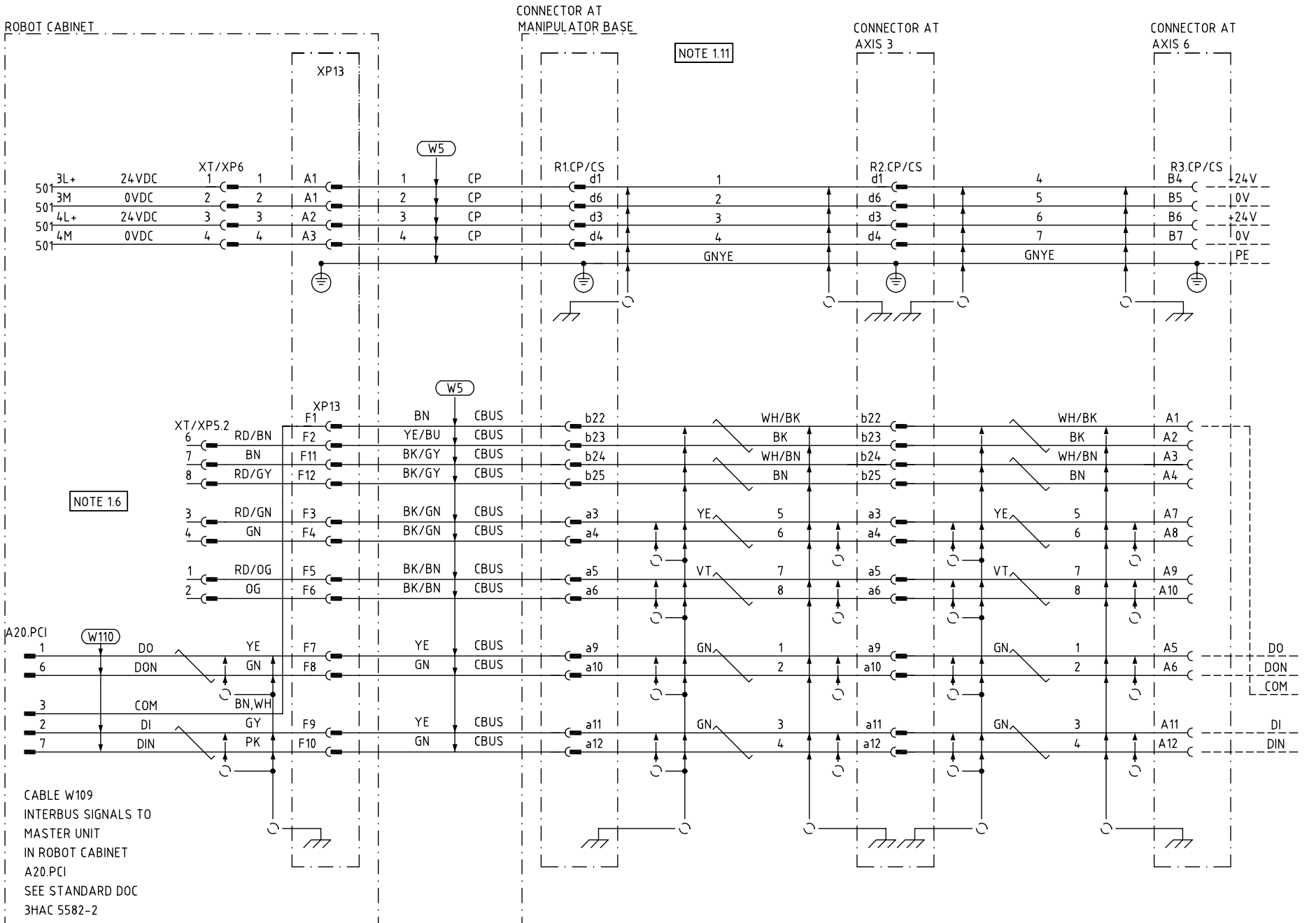

NOTE 1.11

NOTE 1.6

A20.PCI

CABLE W109
INTERBUS SIGNALS TO
MASTER UNIT
IN ROBOT CABINET
A20.PCI
SEE STANDARD DOC
3HAC 5582-2

We reserve all rights in this document and in the information contained therein. Reproduction, use or disclosure to third parties without express authority is strictly forbidden. © Copyright 2003 ABB

CABLES AND EXTERNAL CONNECTIONS
IRB 6600/6650/7600

Latest Revision

Prepared by, date C Blanksvärd, 050318	Responsible department ATMA/RO/AB	Description ACC	Circuit Diagram
Approved by, date M Thunell, 050330	Take over department		
Status Approved		SpotPack for pneum. gun SpotPack för pneum.fång	Sheet 913
ABB ABB Automation Technologies AB			Document No. 3HAC17669-2
			Rev. ind. 03

TYPE S / HS
CUSTOMER POWER
FAN UNIT

POWER UNIT CABINET

OPTION 464-1
COOLING FAN FOR INVERTER OR THYRISTOR

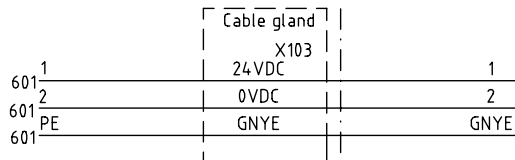

POWER UNIT CABINET

FU100 FAN UNIT

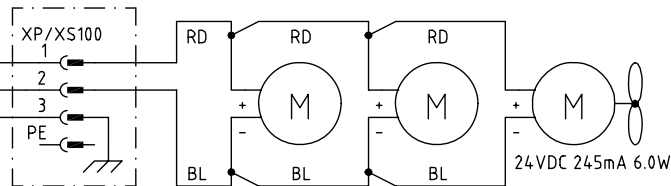

We reserve all rights in this document and in the information contained therein. Reproduction, use or disclosure to third parties without express authority is strictly forbidden. © Copyright 2003 ABB

CABLES AND EXTERNAL CONNECTIONS
IRB 6600/6650/7600

Latest Revision

Prepared by, date C Blanksvärd, 050318	Responsible department ATMA/RO/AB	Description ACC SpotPack for pneum. gun SpotPack för pneum.fång	Circuit Diagram
Approved by, date M Thunell, 050330	Take over department		
Status Approved		Document No. 3HAC17669-2	Sheet 914 No. of sh. 977 Rev. ind. 03

ABB ABB Automation Technologies AB

POWER UNIT CABINET

CUSTOMER POWER/
CUSTOMER SIGNALS
TO WATER AND AIR UNIT
FLOOR HARNESS
3HAC16844-1,-2,-3

TO I/O UNIT

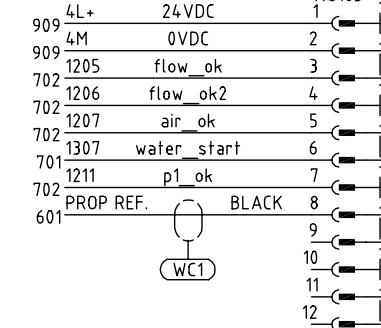

WATER AND AIR UNIT

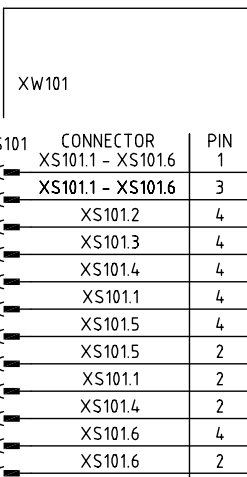

- XS101.1 1
- XS101.1 2
- XS101.1 3
- XS101.1 4
- XS101.1 5
- XS101.2 1
- XS101.2 2
- XS101.2 3
- XS101.2 4
- XS101.2 5
- XS101.3 1
- XS101.3 2
- XS101.3 3
- XS101.3 4
- XS101.3 5
- XS101.4 1
- XS101.4 2
- XS101.4 3
- XS101.4 4
- XS101.4 5
- XS101.5 1
- XS101.5 2
- XS101.5 3
- XS101.5 4
- XS101.5 5
- XS101.6 1
- XS101.6 2
- XS101.6 3
- XS101.6 4
- XS101.6 5

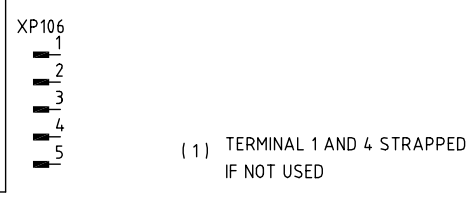
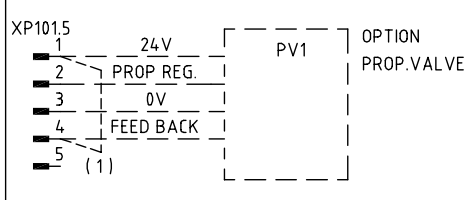
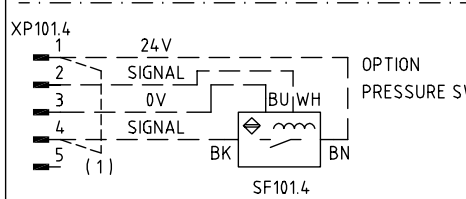
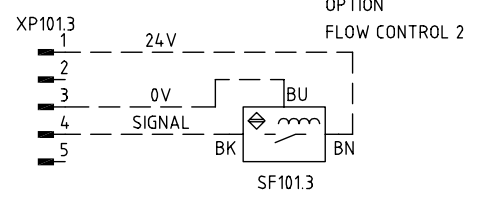
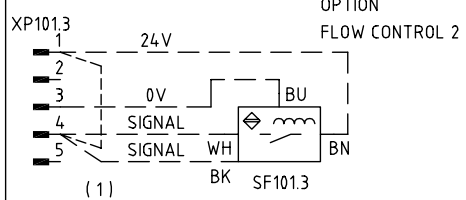
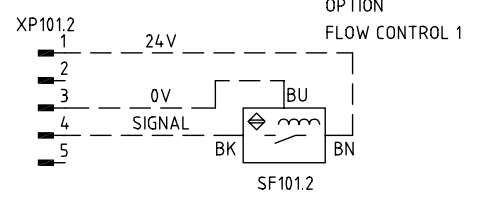
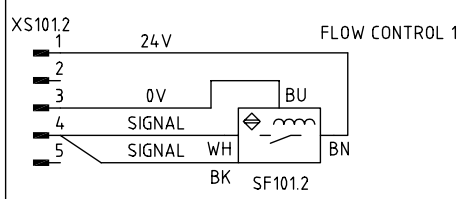
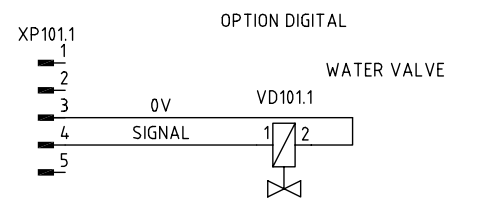
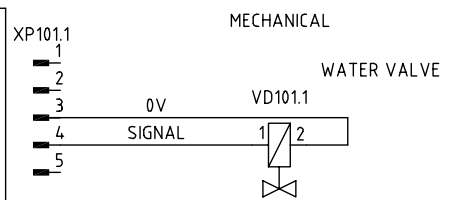

Prepared by, date C Blanksvård, 050318	Responsible department ATMA/RO/AB	Description ACC	Circuit Diagram
Approved by, date M Thunell, 050330	Take over department	SpotPack for pneum. gun SpotPack för pneum.fång	Sheet 915
Status Approved			No. of sh. 977
ABB Automation Technologies AB		Document No. 3HAC17669-2	Rev. ind. 03

CABLES AND EXTERNAL CONNECTIONS
IRB 6600/6650/7600

Latest Revision

We reserve all rights in this document and in the information contained therein. Reproduction, use or disclosure to third parties without express authority is strictly forbidden. © Copyright 2005 ABB

We reserve all rights in this document and in the information contained therein. Reproductions or disclosures to third parties without express authority is strictly forbidden. © Copyright 2012 ABB

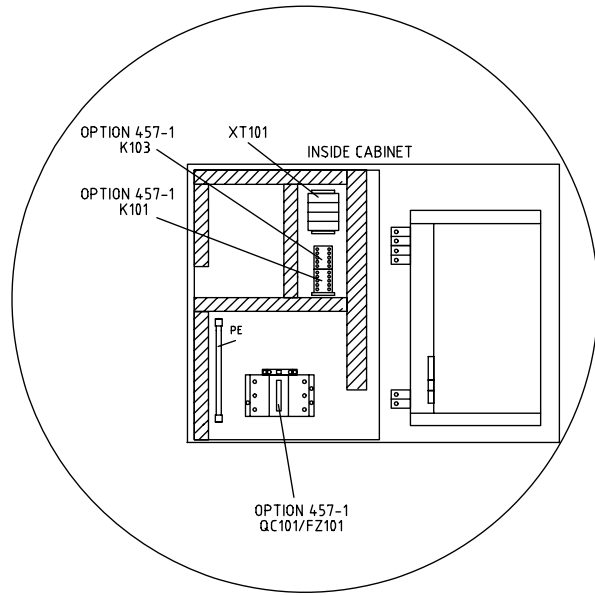

NOTE 1.1
CIRCUIT DIAGRAM: 3HAC17669-2, REV.00

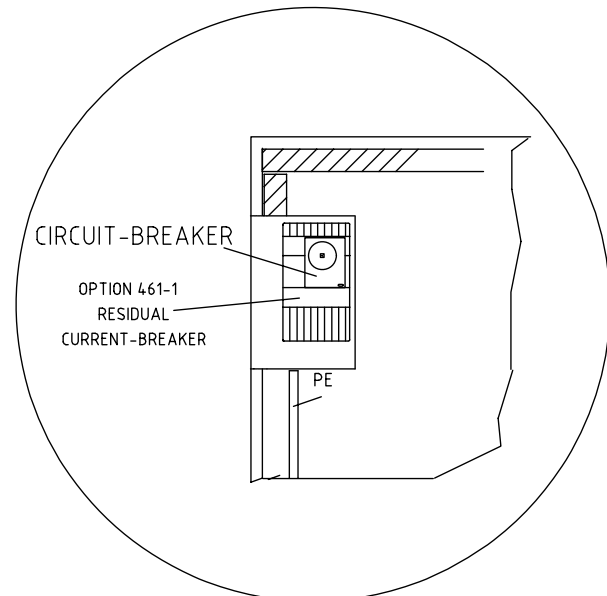

NOTE 1.2
CIRCUIT DIAGRAM: 3HAC17669-2, REV.00

DESIGN CHANGES, NOTE 1.1,1.2
KONSTRUKTIONSÄNDRINGAR, NOT 1.1,1.2
IRB 6600/6650/7600

Latest Revision

Prepared by, date C Blanksvärd, 050316	Responsible department ATMA/RO/AB	Description ACC SpotPack for pneum. gun SpotPack för pneum.tång	Circuit Diagram
Approved by, date M Thunell, 050330	Take over department		
Status Approved		Document No. 3HAC17669-2	Sheet 950 No. of sh. 977 Rev. ind. 03

ABB ABB Automation Technologies AB

We reserve all rights in this document and in the information contained therein. Reproductions or disclosures to third parties without express authority is strictly forbidden. © Copyright 2012 ABB

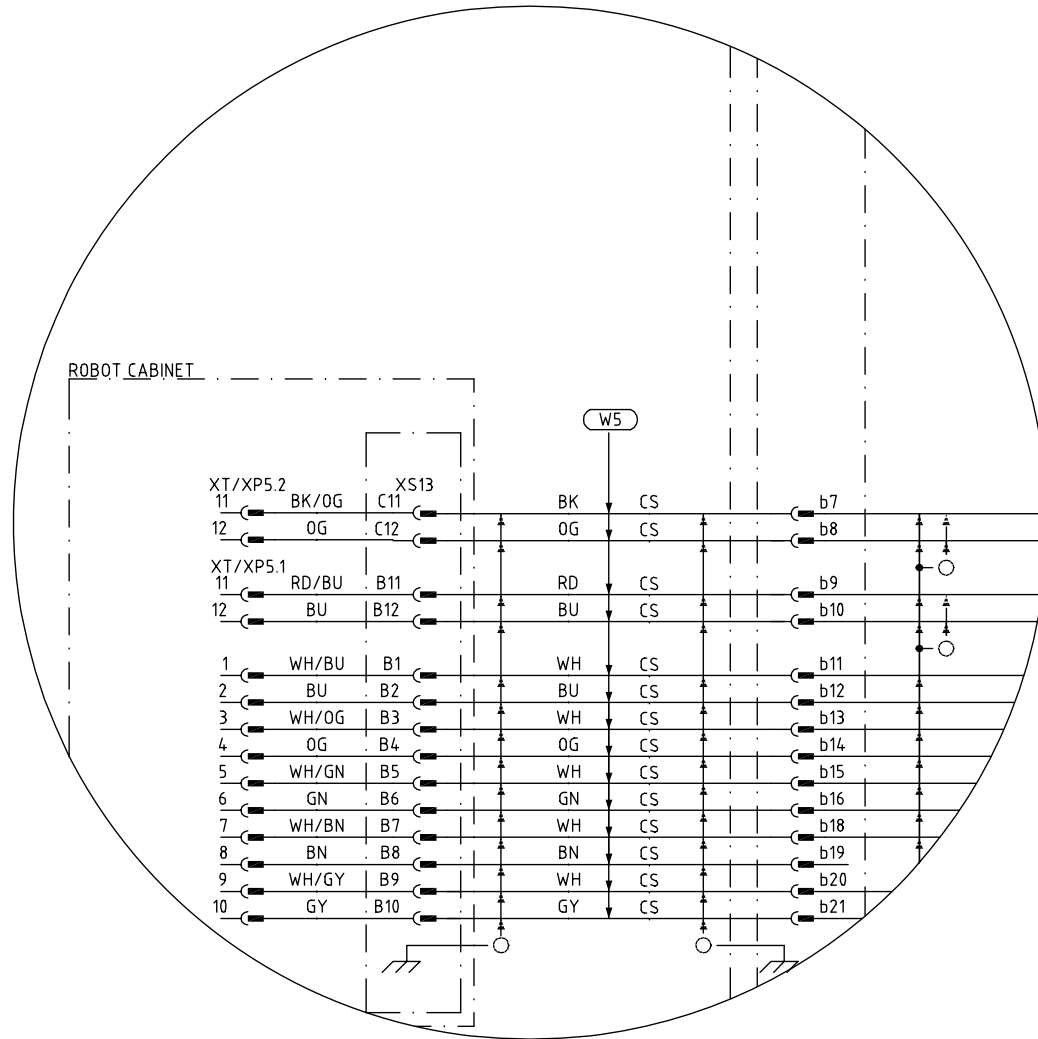

NOTE 1.3
 PARALLEL COMMUNICATION, S/HS
 HARNESS IN CABINET
 3HAC16333-1
 FLOOR HARNESS
 3HAC14890-1,-4,-6,-7

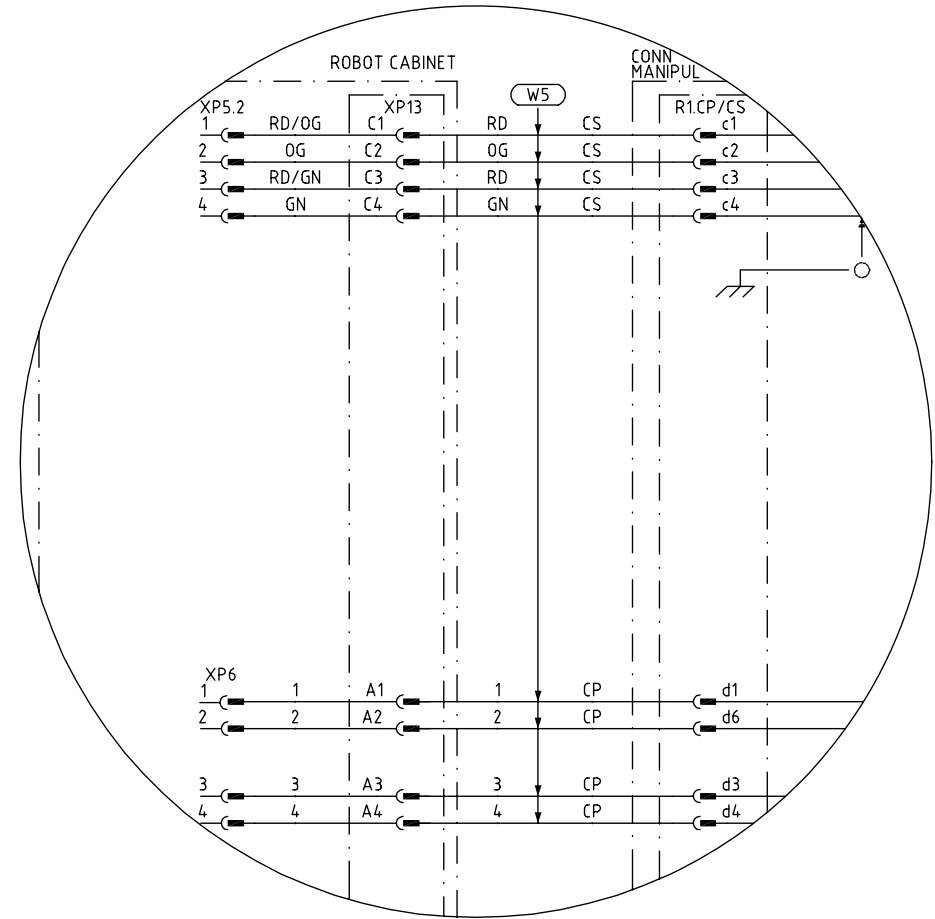

NOTE 1.4
 PARALLEL COMMUNICATION, S/HS
 HARNESS IN CABINET
 3HAC16333-1
 FLOOR HARNESS
 3HAC14890-1,-4,-6,-7

DESIGN CHANGES, NOTE 1.3,1.4
 KONSTRUKTIONSÄNDRINGAR, NOT 1.3,1.4
 IRB 6600/6650/7600

Latest Revision

Prepared by, date C Blanksvård, 050316	Responsible department ATMA/RO/AB	Description ACC	Circuit Diagram
Approved by, date M Thunell, 050330	Take over department	SpotPack for pneum. gun SpotPack för pneum.fång	Sheet 951
Status Approved			No. of sh. 977
ABB ABB Automation Technologies AB		Document No. 3HAC17669-2	Rev. ind. 03

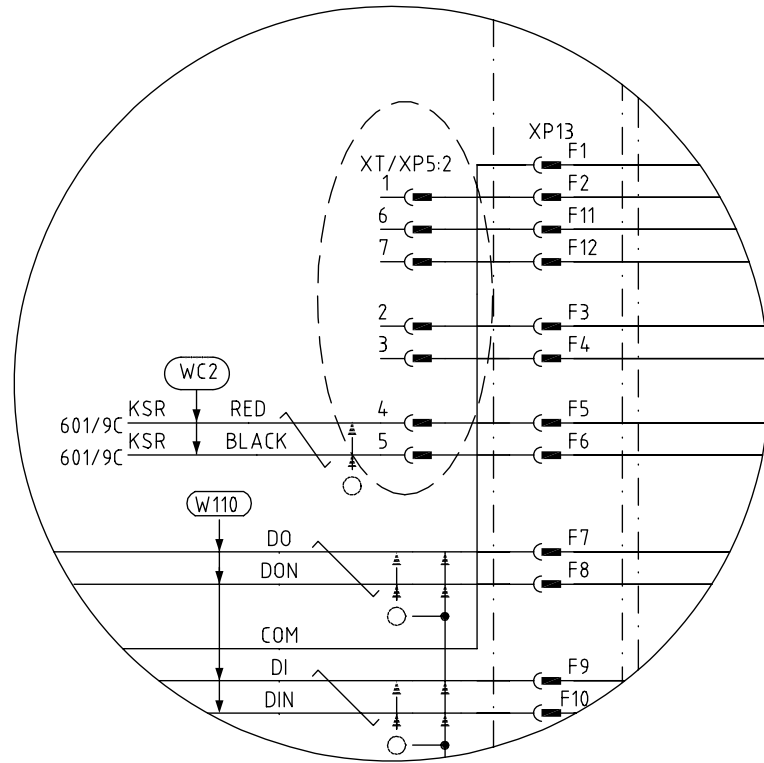

NOTE 1.5
 HARNESS IN CABINET
 INTERBUS COMMUNICATION, S
 3HAC16905-1, REV.00

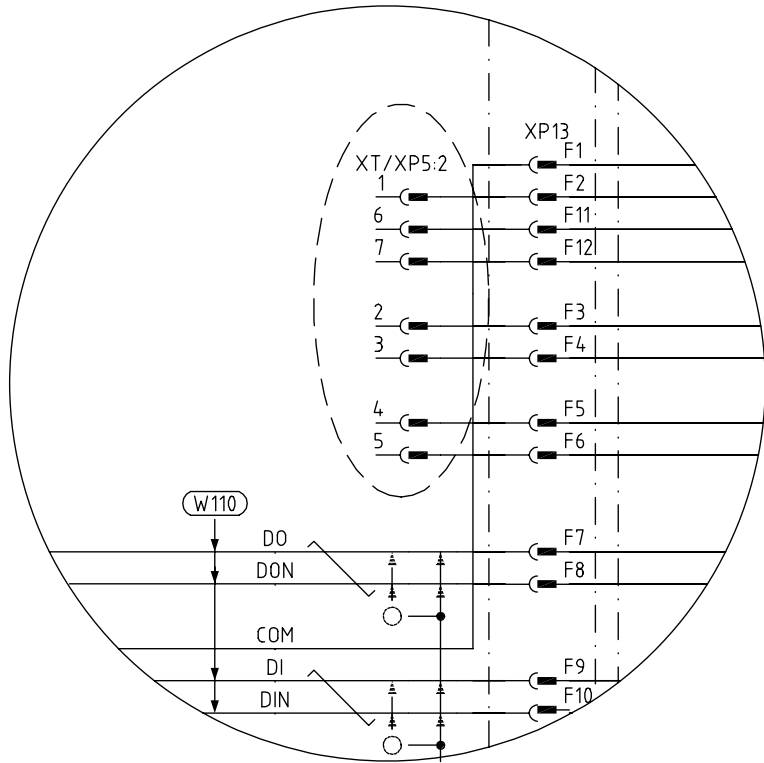

NOTE 1.6
 HARNESS IN CABINET
 INTERBUS COMMUNICATION, HS
 3HAC16905-1, REV.00

We reserve all rights in this document and in the information contained therein. Reproductions or disclosures to third parties without express authority is strictly forbidden. © Copyright 2010 ABB

DESIGN CHANGES, NOTE 1.5,1.6
 KONSTRUKTIONSÄNDRINGAR, NOT 1.5,1.6
 IRB 6600/6650/7600

Latest Revision

Prepared by, date C Blanksvård, 050316	Responsible department ATMA/RO/AB	Description ACC SpotPack for pneum. gun SpotPack för pneum.tång	Circuit Diagram
Approved by, date M Thunell, 050330	Take over department		
Status Approved		Document No. 3HAC17669-2	No. of sh. 977 Rev. ind. 03

We reserve all rights in this document and in the information contained therein. Reproductions or disclosures to third parties without express authority is strictly forbidden. © Copyright 2010 ABB

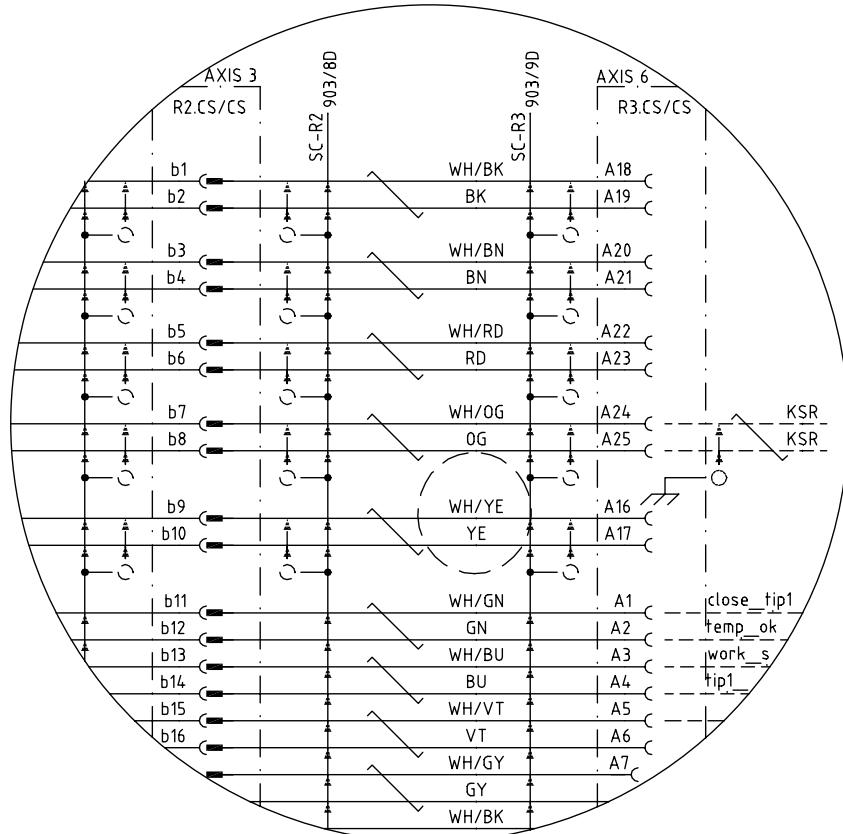

NOTE 1.7

UPPER ARM HARNESS
 PARALLEL COMMUNICATION, S
 3HAC16643-1,-2,-3, REV.00,01,02
 3HAC16645-1,-2,-3, REV.00,01
 PARALLEL COMMUNICATION, HS
 3HAC16647-1,-2,-3,-4,-5, REV.00,01

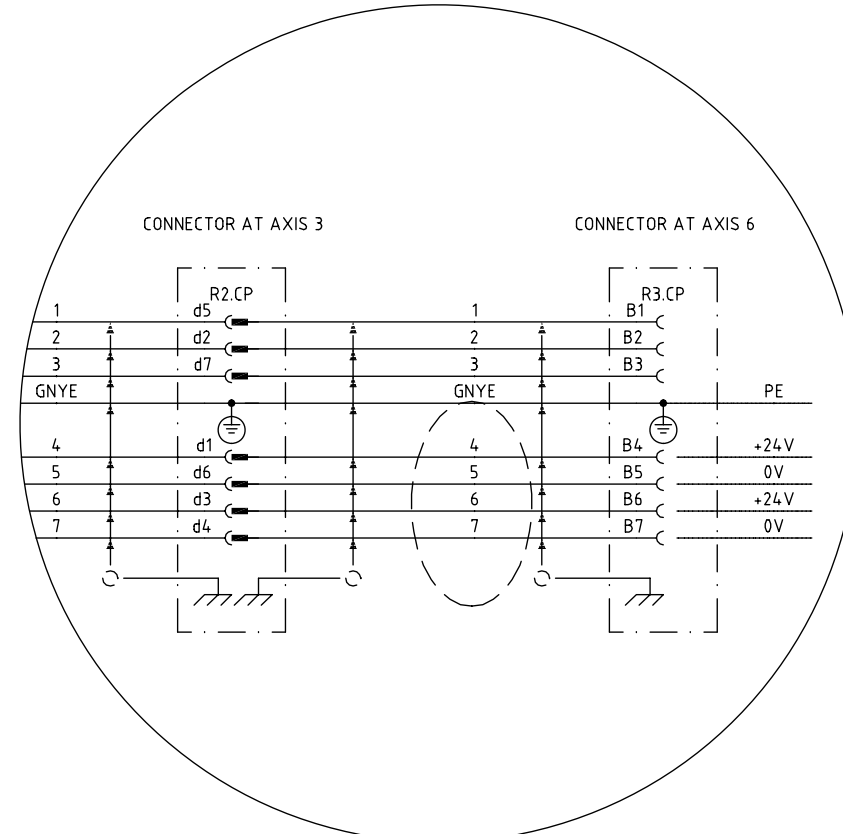

NOTE 1.8

UPPER ARM HARNESS
 PARALLEL COMMUNICATION, S
 3HAC16643-1,-2,-3, REV.00,01,02
 3HAC16645-1,-2,-3, REV.00,01
 PARALLEL COMMUNICATION, HS
 3HAC16647-1,-2,-3,-4,-5, REV.00,01

DESIGN CHANGES, NOTE 1.7,1.8
 KONSTRUKTIONSÄNDRINGAR, NOT 1.7,1.8
 IRB 6600/6650/7600

Latest Revision

Prepared by, date C Blanksvård, 050316	Responsible department ATMA/RO/AB	Description ACC SpotPack for pneum. gun SpotPack för pneum.fång	Circuit Diagram
Approved by, date M Thunell, 050330	Take over department		
Status Approved		Document No. 3HAC17669-2	Sheet 953 No. of sh. 977 Rev. ind. 03

ABB ABB Automation Technologies AB

We reserve all rights in this document and in the information contained therein. Reproductions or disclosures to third parties without express authority is strictly forbidden. © Copyright 2012 ABB

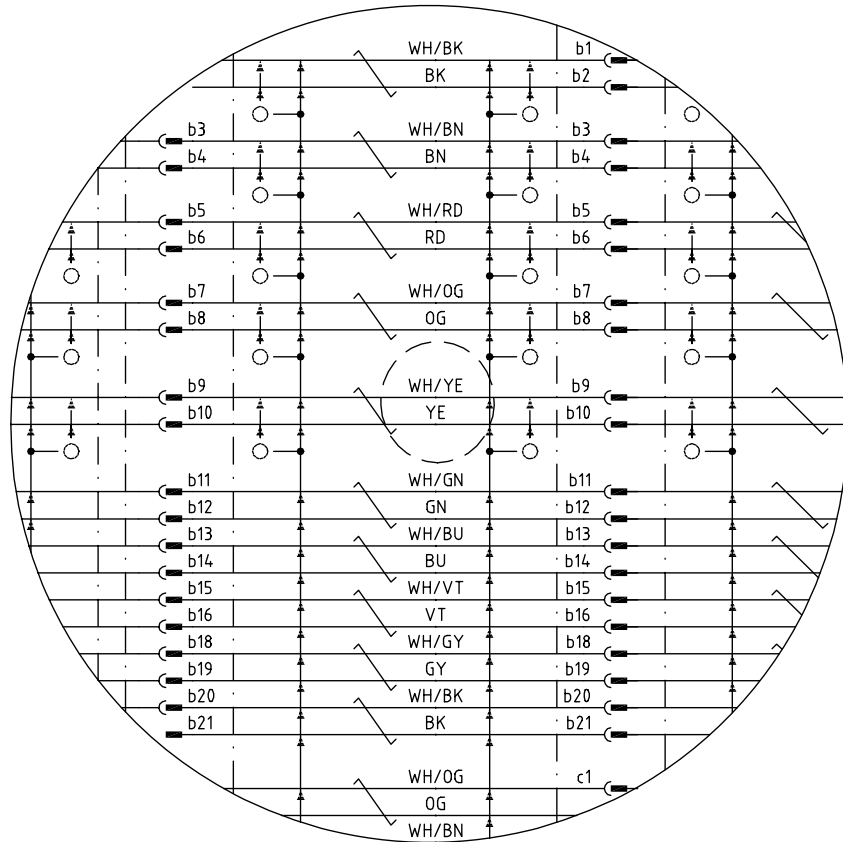

NOTE 1.9

LOWER ARM HARNESS
 PARALLEL COMMUNICATION, HS
 3HAC16792-1
 3HAC16793-1

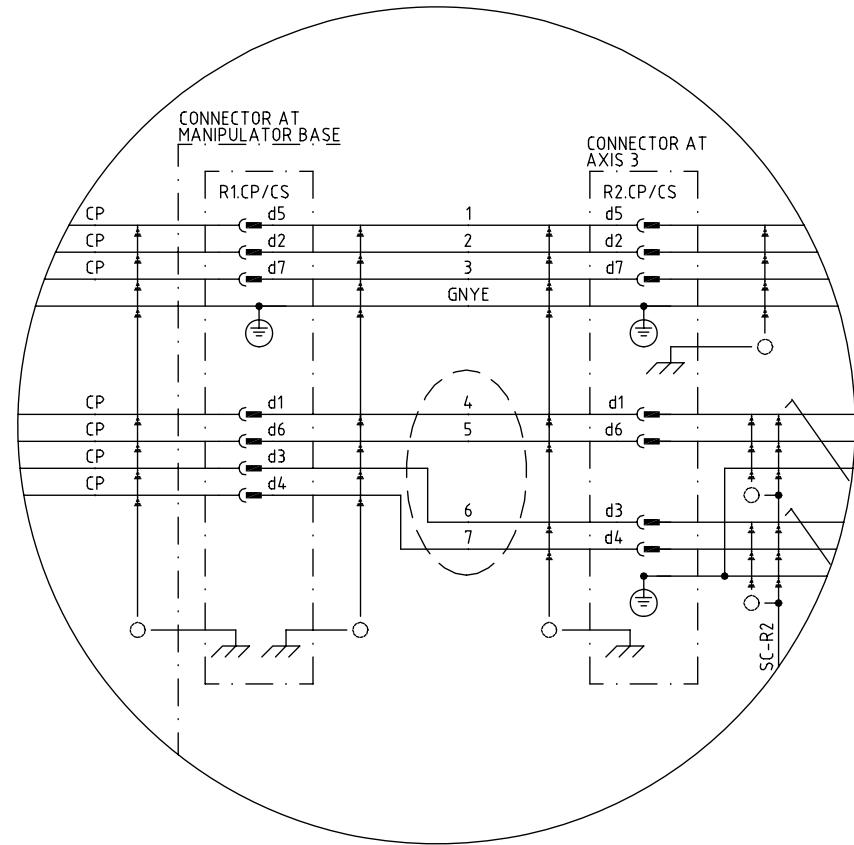

NOTE 1.10

LOWER ARM HARNESS
 PARALLEL COMMUNICATION, HS
 3HAC16792-1
 3HAC16793-1

DESIGN CHANGES, NOTE 1.9,1.10
 KONSTRUKTIONSÄNDRINGAR, NOT 1.9,1.10
 IRB 6600/6650/7600

Latest Revision

Prepared by, date C Blanksvärd, 050316	Responsible department ATMA/RO/AB	Description ACC SpotPack for pneum. gun SpotPack för pneum.fång	Circuit Diagram
Approved by, date M Thunell, 050330	Take over department		
Status Approved		Document No. 3HAC17669-2	Sheet 954 No. of sh. 977 Rev. ind. 03

ABB ABB Automation Technologies AB

We reserve all rights in this document and in the information contained therein. Reproductions or disclosures to third parties without express authority is strictly forbidden. © Copyright 2012 ABB

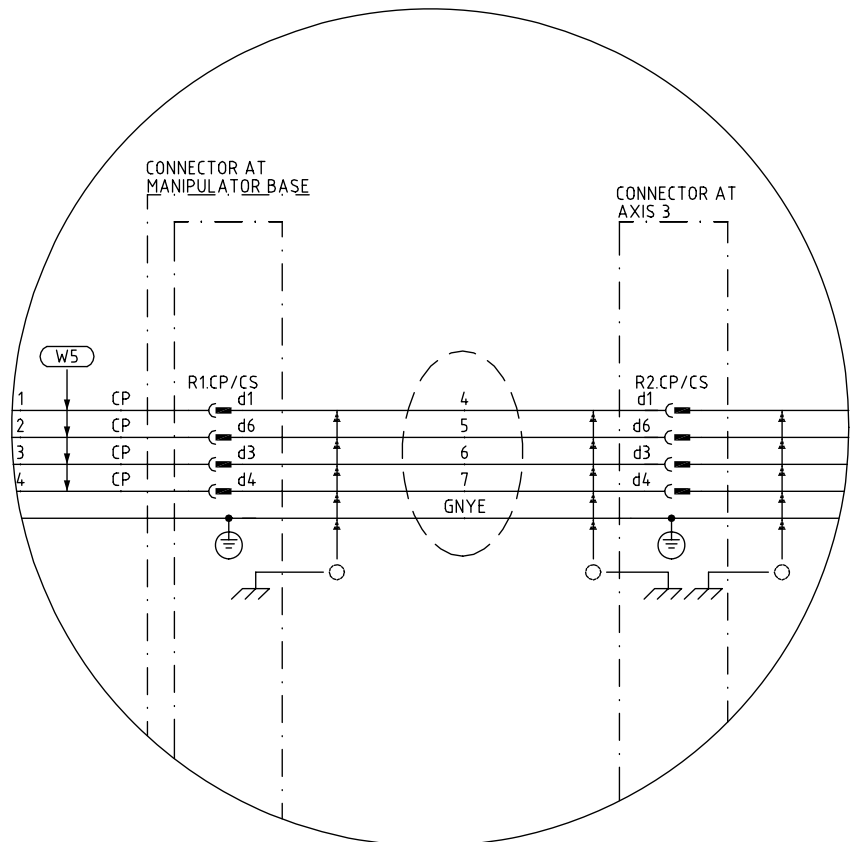

NOTE 1.11
 LOWER ARM HARNESS
 BUS COMMUNICATION, HS
 3HAC16796-1
 3HAC16797-1

DESIGN CHANGES, NOTE 1.11
 KONSTRUKTIONSÄNDRINGAR, NOT 1.11
 IRB 6600/6650/7600

Latest Revision

Prepared by, date C Blanksvård, 050316	Responsible department ATMA/RO/AB	Description ACC SpotPack for pneum. gun SpotPack för pneum.tång	Circuit Diagram
Approved by, date M Thunell, 050330	Take over department		
Status Approved		Document No. 3HAC17669-2	Sheet 955 No. of sh. 977 Rev. ind. 03

ABB Automation Technologies AB

Cable CP/CS

R1.CP/CS

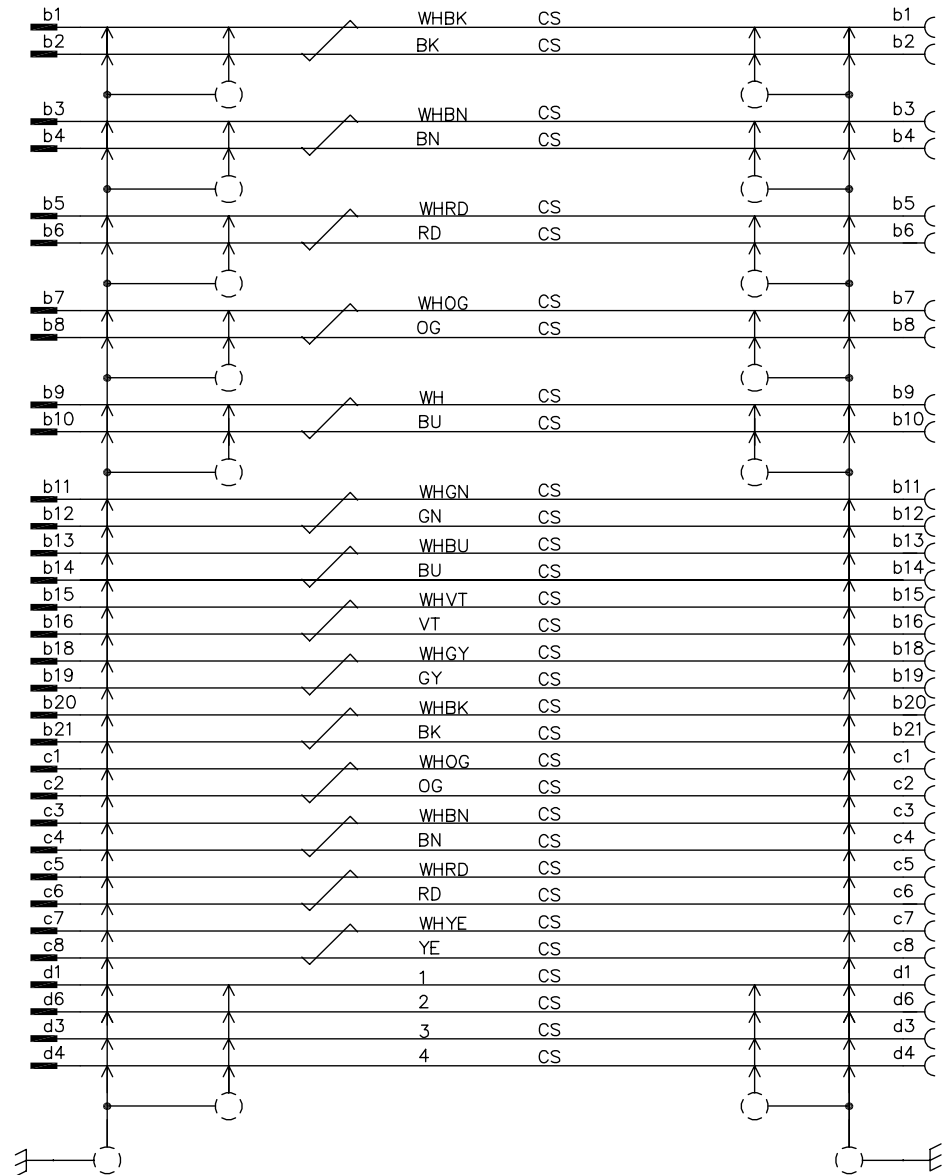

Cable CP

R1.CP/CS

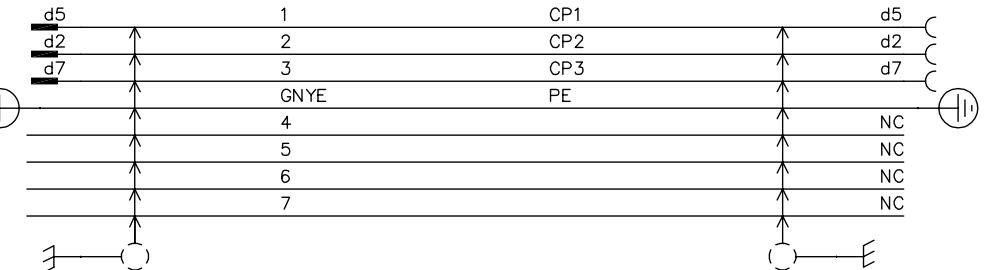

Cable CBUS

R1.CP/CS

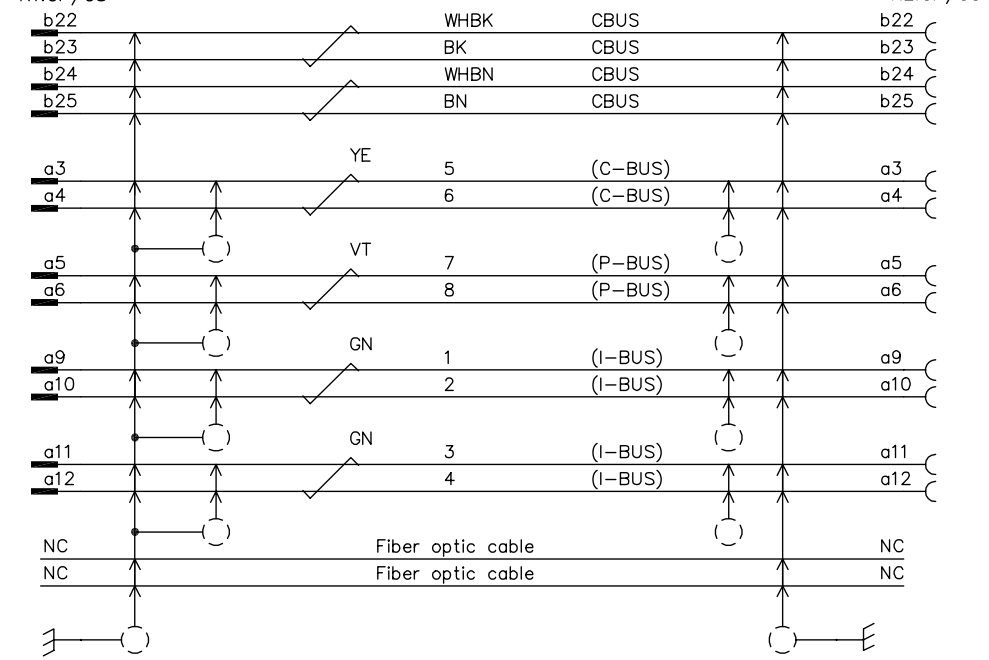

LOWER ARM HARNESS
3HAC020126-001 REV.00,01
3HAC020304-001 REV.00,01,02

Prepared by, date C Blanksvård, 050316	Responsible department ATMA/RO/AB	Description ACC SpotPack for pneum. gun SpotPack för pneum.fång	Circuit Diagram
Approved by, date M Thunell, 050330	Take over department		
Status Approved		Document No. 3HAC17669-2	No. of sh. 970 Rev. ind. 03

CUSTOMER POWER/SIGNAL, AX1-3 MH EXT
KUNDKABLAGE KRAFT/SIGNAL, AX1-3 MH EXT
IRB 6600/6650/7600

Latest Revision

ABB ABB Automation Technologies AB

We reserve all rights in this document and in the information contained therein. Reproductions, use or disclosure to third parties without express authority is strictly forbidden. © Copyright 2012 ABB

Cable CP/CS

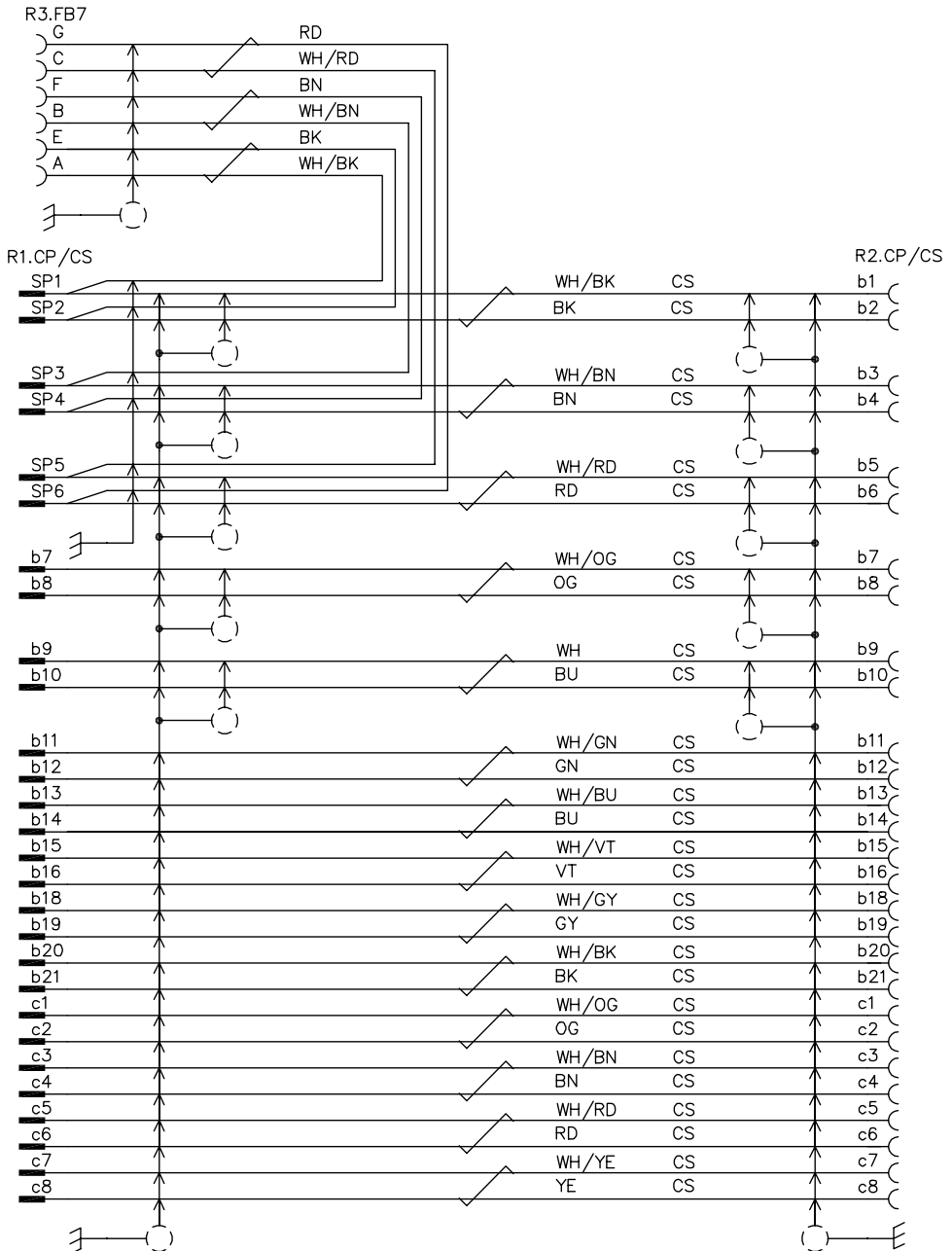

Cable CP

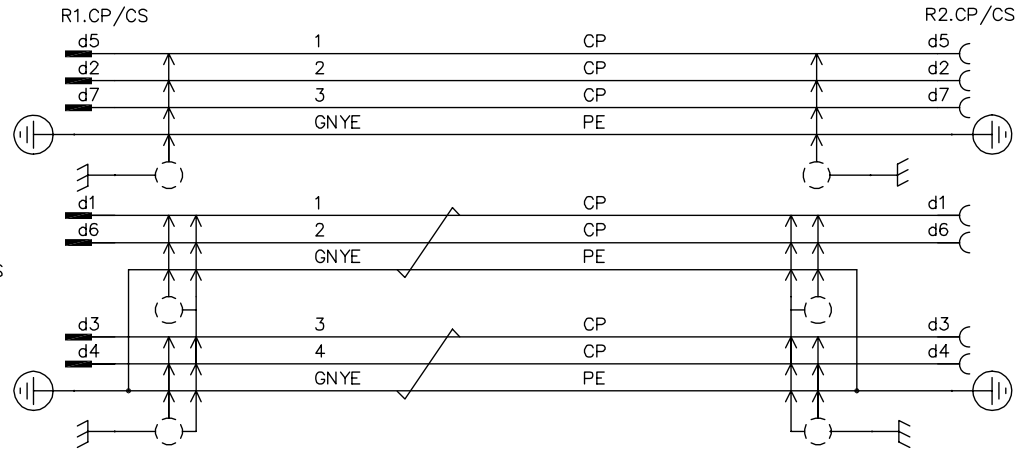

Cable FB

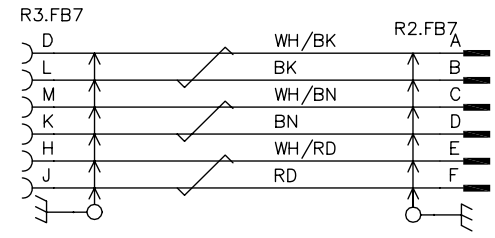

LOWER ARM HARNESS
 3HAC16782-1 REV.01
 3HAC16783-1 REV.02
 3HAC16788-1 REV.01
 3HAC16789-1 REV.02

Prepared by, date C Blanksvård, 050316	Responsible department ATMA/R0/AB	Description ACC SpotPack for pneum. gun SpotPack för pneum.fång	Circuit Diagram
Approved by, date M Thunell, 050330	Take over department		
Status Approved		Document No. 3HAC17669-2	Sheet 971 No. of sh. 977 Rev. ind. 03

CUSTOMER POWER/SIGNAL, LOWER ARM CP/CBUS+SERVOS
 KUNDKABLAG KRAFT/SIGNAL, UNDERARM CP/CBUS+SERVO
 IRB 6600/6650/7600

Latest Revision

ABB ABB Automation Technologies AB

We reserve all rights in this document, and in the information contained therein. Reproductions, use or disclosure to third parties without express authority is strictly forbidden. © Copyright 2012 ABB

1

2

3

4

5

6

A

B

C

D

A

B

C

D

Cable FB

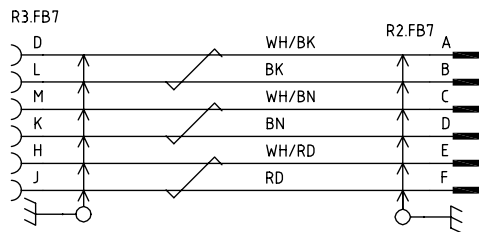

LOWER ARM HARNESS
3HAC020447-001 REV.01

7th AXIS, SERIAL CABLE
7:e AXIS, SERIEMÄTKABEL
IRB 6600/6650/7600

Latest Revision

Prepared by, date C Blanksvärd, 050316	Responsible department ATMA/RO/AB	Description ACC Circuit Diagram 	Sheet 972
Approved by, date M Thunell, 050330	Take over department		No. of sh. 977
Status Approved	Document No. 3HAC17669-2		Rev. ind. 03

ABB ABB Automation Technologies AB

1

2

3

4

5

6

Cable CP/CS

R1.CP/CS

R2.CP/CS

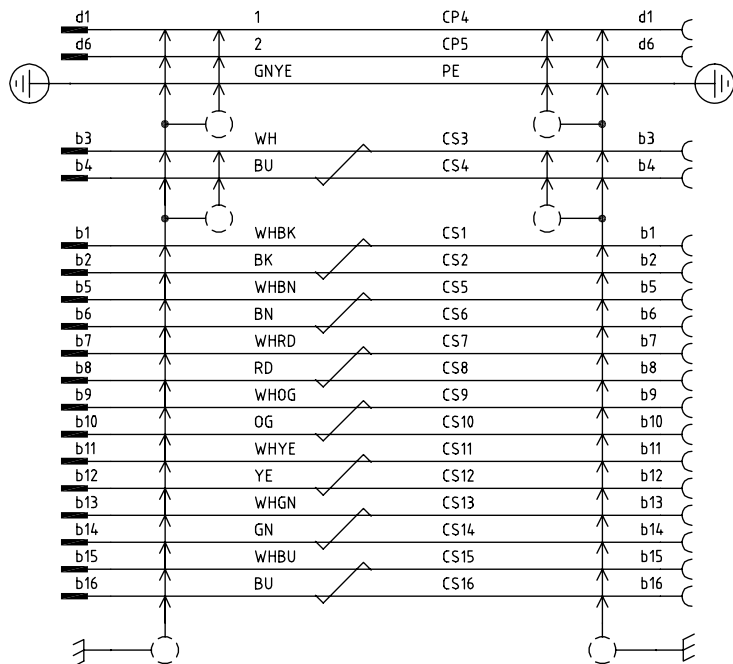

We reserve all rights in this document and in the information contained therein. Reproductions or disclosures to third parties without express authority is strictly forbidden. © Copyright 2012 ABB

LOWER ARM HARNESS
 3HAC020179-001 REV.00,01
 3HAC020303-001 REV.00,01,02

Prepared by, date C Blanksvärd, 050316	Responsible department ATMA/RO/AB	Description ACC Circuit Diagram	Sheet 973
Approved by, date M Thunell, 050330	Take over department		No. of sh. 977
Status Approved		Document No. 3HAC17669-2	Rev. ind. 03

CUSTOMER POWER/SIGNAL, AX1-3 MH STD
 KUNDKABLAGE KRAFT/SIGNAL/BUS, AX1-3 MH STD
 IRB 6600/6650/7600

Latest Revision

ABB ABB Automation Technologies AB

Cable
CP/CS
R2.CP/CS

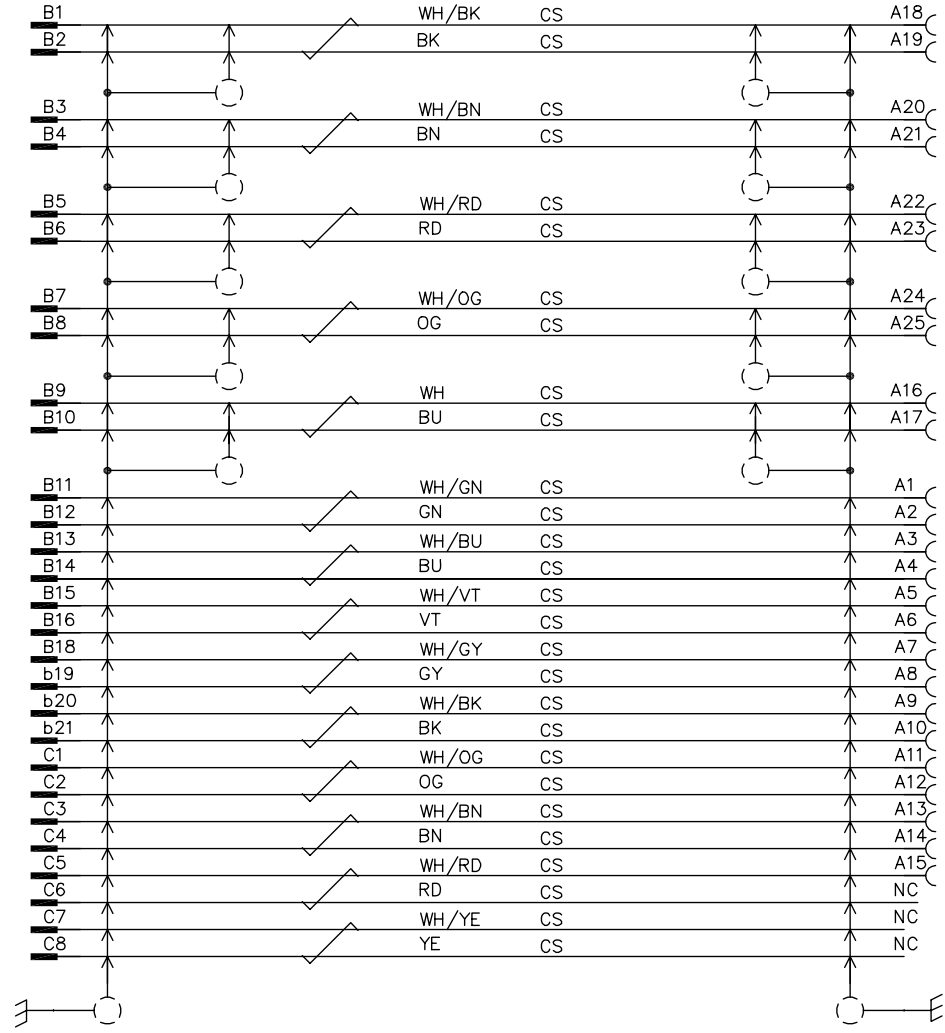

Cable
CP
R2.CP/CS

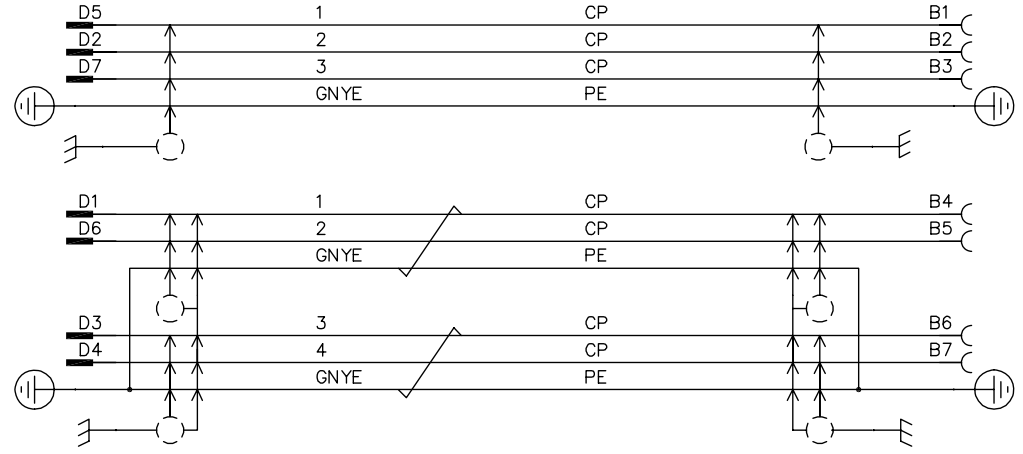

R3.CP/CS

R3.CP/CS

We reserve all rights in this document, and in the information contained therein. Reproductions, use or disclosure to third parties without express authority is strictly forbidden. © Copyright 2012 ABB

UPPER ARM HARNESS
 3HAC16643-1,-2,-3 REV.03,04
 3HAC16645-1,-2,-3 REV.02,03
 3HAC16647-1,-2,-3,-4,-5 REV.02,03

CUSTOMER POWER/SIGNAL, UPPER ARM CP/CS
 KUNDKABLAGE KRAFT/SIGNAL/BUS, ÖVERARM CP/CS
 IRB 6600/6650/7600

Latest Revision

Prepared by, date C Blanksvärd, 050316	Responsible department ATMA/R0/AB	Description ACC SpotPack for pneum. gun SpotPack för pneum.fång	Circuit Diagram
Approved by, date M Thunell, 050330	Take over department		
Status Approved		Document No. 3HAC17669-2	No. of sh. 974 Rev. ind. 977 03

ABB ABB Automation Technologies AB

Cable
CP

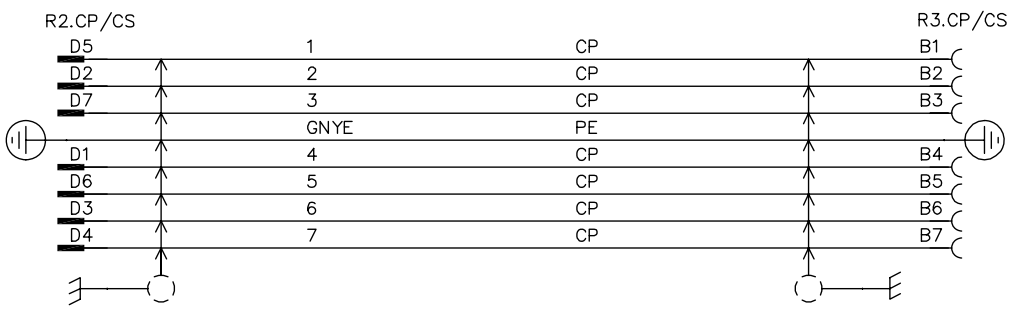

Cable
CBUS

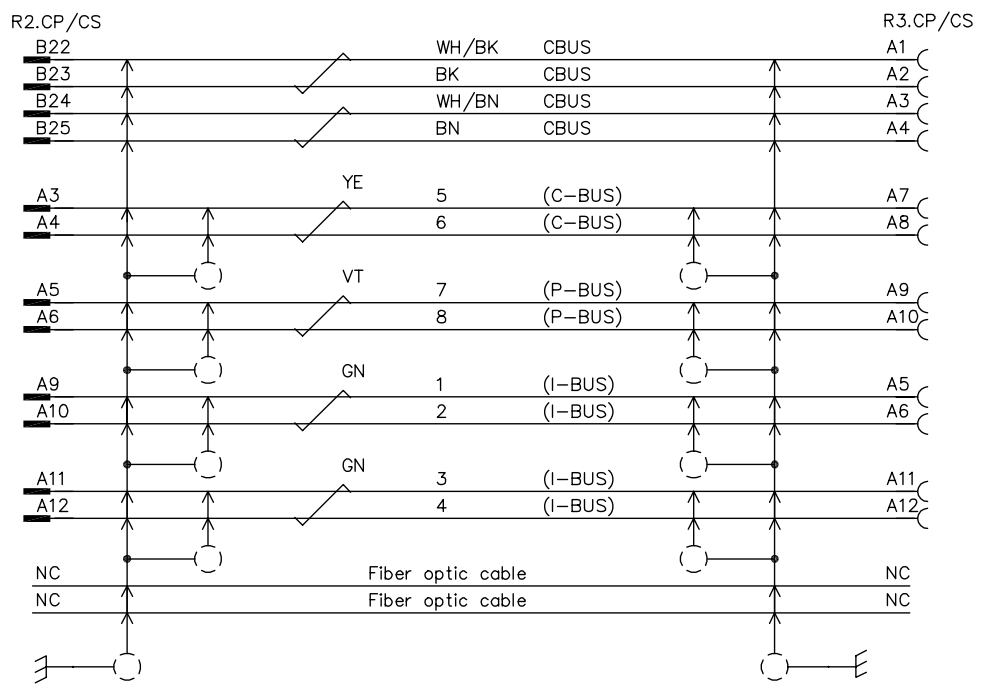

- UPPER ARM HARNESS
- 3HAC16644-1 REV.00,01,02,03
 - 3HAC16644-2 REV.00,01,02
 - 3HAC16644-3 REV.00,01,02
 - 3HAC16646-1 REV.00,01,02
 - 3HAC16646-2 REV.00,01,02
 - 3HAC16646-3 REV.00,01,02
 - 3HAC16648-1 REV.00,01,02
 - 3HAC16648-2 REV.00,01,02
 - 3HAC16648-3 REV.00,01,02
 - 3HAC16648-4 REV.00,01,02
 - 3HAC16648-5 REV.00,01,02

We reserve all rights in this document and in the information contained therein. Reproductions, use or disclosure to third parties without express authority is strictly prohibited. © Copyright 2012 ABB

Prepared by, date C Blanksvård, 050316	Responsible department ATMA/RO/AB	Description ACC SpotPack for pneum. gun SpotPack för pneum.fång	Circuit Diagram
Approved by, date M Thunell, 050330	Take over department		
Status Approved		Document No. 3HAC17669-2	No. of sh. 975 Rev. ind. 03

CUSTOMER POWER/SIGNAL, UPPER ARM CP/CBUS
KUNDKABLAGE KRAFT/SIGNAL, ÖVERARM CP/CBUS
IRB 6600/6650/7600

Latest Revision

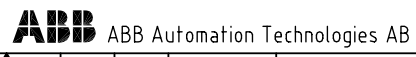

Cable

CP/CS

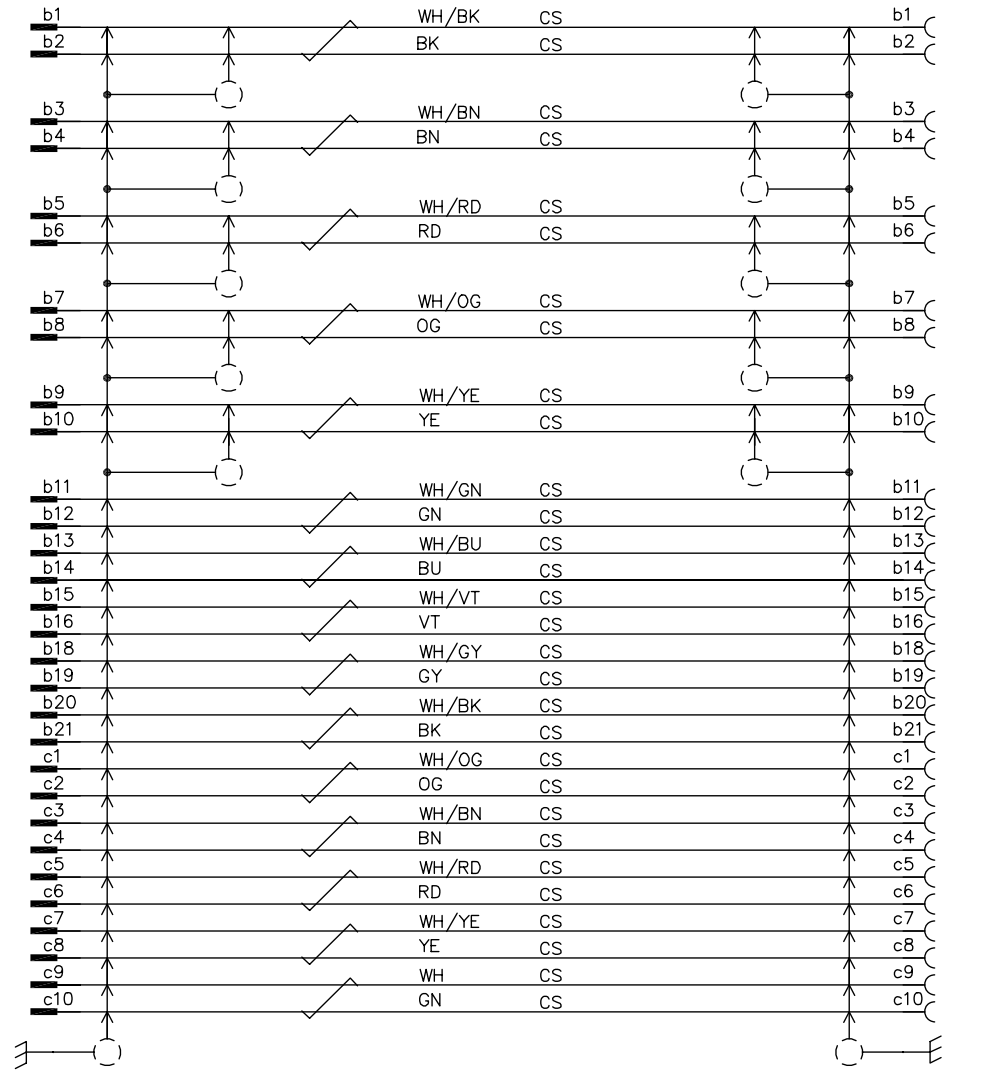

Cable

CP

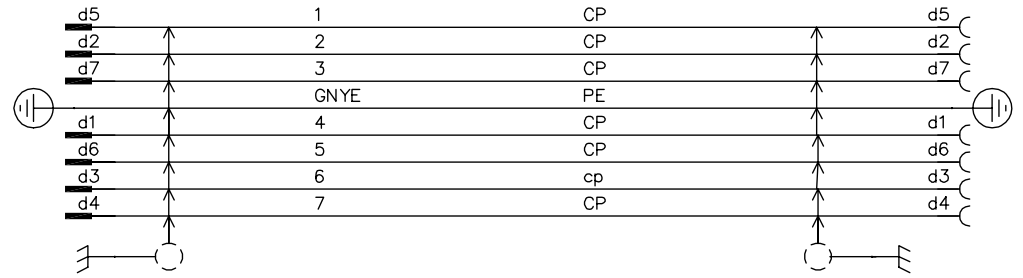

LOWER ARM HARNESS
 3HAC16780-1 REV.00
 3HAC16781-1 REV.00,01
 3HAC16786-1 REV.00
 3HAC16787-1 REV.00,01

We reserve all rights in this document, and in the information contained therein. Reproductions, use or disclosure to third parties without express authority is strictly prohibited. © Copyright 2002 ABB

Prepared by, date C Blanksvärd, 050316	Responsible department ATMA/R0/AB	Description ACC SpotPack for pneum. gun SpotPack för pneum.fång	Circuit Diagram
Approved by, date M Thunell, 050330	Take over department		
Status Approved		Document No. 3HAC17669-2	Sheet 976 No. of sh. 977 Rev. ind. 03

CUSTOMER POWER/SIGNAL, LOWER ARM CP/CS
 KUNDKABLAGE KRAFT/SIGNAL, UNDERARM CP/CS
 IRB 6600/6650/7600

Latest Revision

ABB ABB Automation Technologies AB

Cable
CP/CS
R1.CP/CS

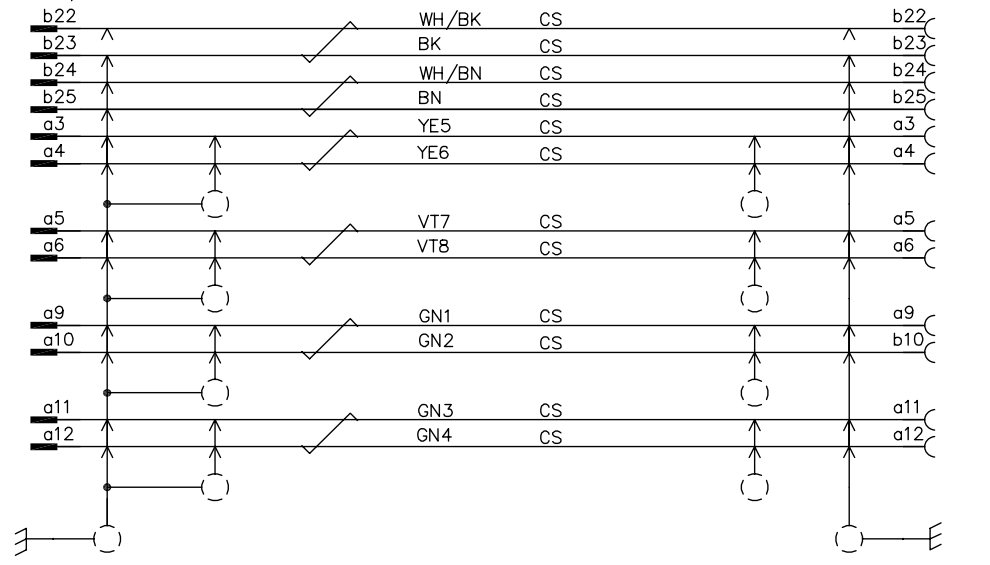

Cable
CP
R1.CP/CS

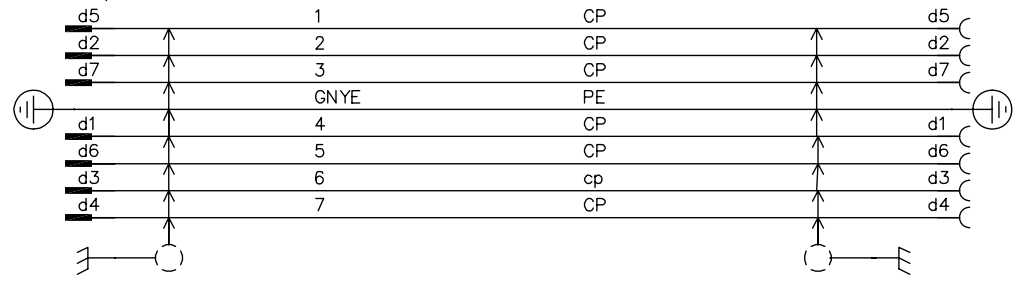

R2.CP/CS

We reserve all rights in this document and in the information contained therein. Reproductions, use or disclosure to third parties without express authority is strictly forbidden. © Copyright 2012 ABB

LOWER ARM HARNESS
 3HAC16784-1 REV.00
 3HAC16785-1 REV.00,01
 3HAC16790-1 REV.00
 3HAC16791-1 REV.00,01

Prepared by, date C Blanksvärd, 050316	Responsible department ATMA/RO/AB	Description ACC Circuit Diagram	Sheet 977
Approved by, date M Thunell, 050330	Take over department		
Status Approved		SpotPack for pneum. gun SpotPack för servotång	No. of sh. 977
Document No. 3HAC17669-2			Rev. ind. 03

CUSTOMER POWER/SIGNAL, LOWER ARM CP/CBUS
 KUNDKABLAGA KRAFT/SIGNAL, UNDERARM CP/CBUS
 IRB 6600/6650/7600

Latest Revision

ABB ABB Automation Technologies AB



ABB Automation Technologies AB
Robotics
S-721 68 VÄSTERÅS
SWEDEN
Telephone: +46 (0) 21 344000
Telefax: +46 (0) 21 132592

3HAC 17667-1, Revision A, en