



Air Booster (AB121 & AB221)

Your configured part number: AB121-ARB800x0.125

Max boosted pressure will be 10% to 20% less than 2x input pressure due to system pressure drops.

Features and Benefits

- **2:1 Ratio Air-to-Air Booster:**
 - Compact and self-contained
 - Incorporates integral valve components to perform auto-reciprocating function
 - Estimated charge time: 28 seconds per 1 gallon reservoir
- **Amplify Inadequate Air Pressure:**
 - Increase the input PSI to provide a quick and cost effective solution
- **Air Booster Intent:**
 - Designed for intermittent duty usage such as maintaining pressure in an air reservoir
 - Continuous cycling decreases seal life

Engineering Specifications

Maximum Input Pressure: 125 PSI
Operating Temperature: 15°F to 160°F
Lubrication: HT-99 oil; Pre-lubricated
Bodies & Center Section: Aluminum; Hard Coat with PTFE
Mounting Plate: Anodized Aluminum
Assembly Screws: Zinc Plated Carbon Steel

Service and Design Capabilities

- **Most air boosters ship in two to three days**
- **Rush services available for most products**
- **Made-to-order custom design capabilities for your needs**
- **Basic Flow – AB121**
- **High Flow – AB221**
- **Compatible with TRD's Air Reservoir products**

Bimba Manufacturing Company
Monee, IL 60449-0068
Telephone: 708.534.8544
Toll Free: 800-44-BIMBA
Email: cs@bimba.com
www.bimba.com

Leaders in Actuation.

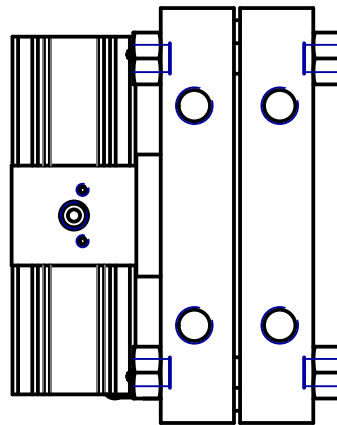
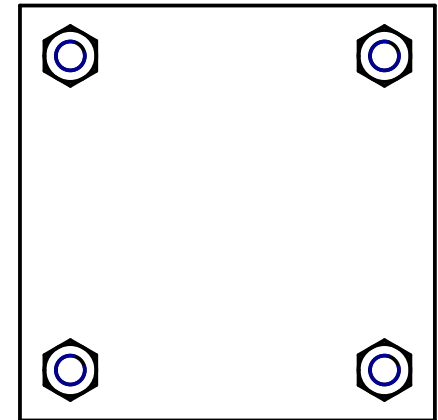
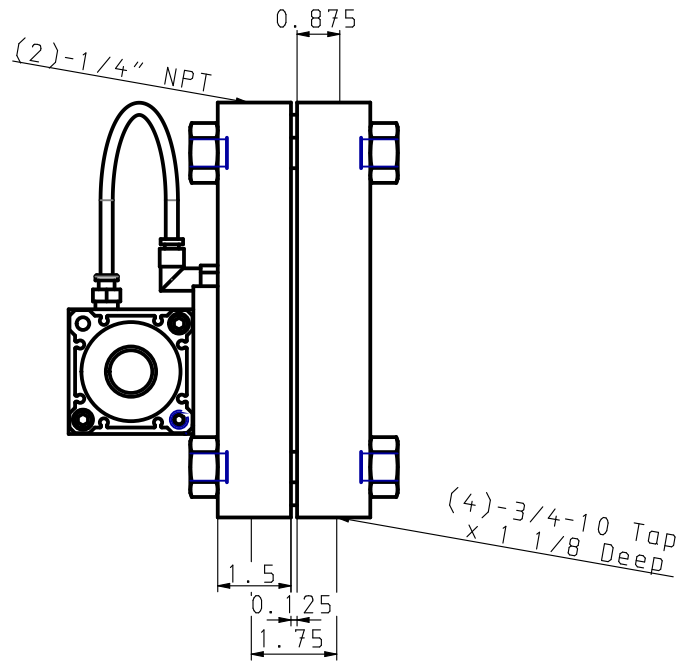
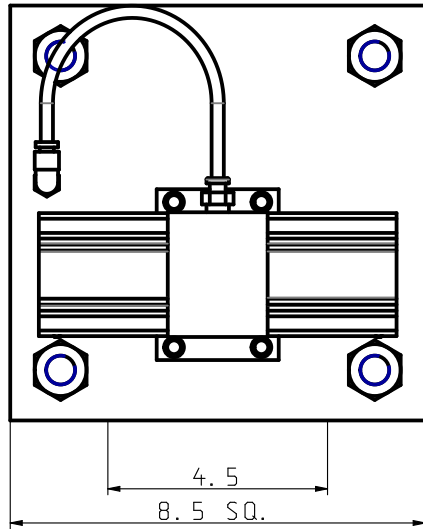

AB121-ARB800x0.125

Max boosted pressure will be 10% to 20% less than 2x input pressure due to system pressure drops.

THIS DRAWING CONTAINS PROPRIETARY DESIGNS AND/OR INFORMATION OF BIMBA MFG. CO. OR ITS SUBSIDIARIES AND IS NOT TO BE TRANSMITTED, REPRODUCED, USED OR DISCLOSED WITHOUT WRITTEN PERMISSION OF BIMBA MFG. CO. OR ITS SUBSIDIARIES. DESIGN REFLECTS OUR BEST ENGINEERING OPINION BASED ON WRITTEN APPLICATION SPECIFICATIONS RECEIVED. SUITABILITY OF A DESIGN FOR AN APPLICATION REQUIRES ANALYSIS AND/OR TESTS IN YOUR SPECIFIC SYSTEM.

Bimba is part of
IMI Precision Engineering



Bimba Manufacturing Co.

Monee, IL. 60449
(800) 442-4622 www.bimba.com

PROPRIETARY DRAWING - Reference Only