

SWIFTI™ CRB 1100

Unleash the speedy cobot

A lightning-fast cobot that combines industrial-level performance and innovative safety. SWIFTI gets the job done faster and more accurately than you can imagine.



Introducing SWIFTI

SWIFTI bridges the gap between collaborative and industrial robots. It enables proven safe collaborative operation to be achieved, even in applications that demand industrial-level speed and lifting capabilities.

Collaborative safety

Combining ABB's SafeMove comprehensive safety functionality with a safety laser scanner,* SWIFTI can be installed without physical fencing and still collaborate safely with people. If a worker is detected within its working area, SWIFTI will automatically slow down or halt to allow them to approach safely. An interaction light also provides a visual indication of SWIFTI's status. It signals human co-workers when people are inside SWIFTI's working zone.

No experience? No problem.

Offering both lead-through programming – via a clip-on lead-through device, Wizard easy programming software, and the graphical SafeMove configurator App on the FlexPendant, SWIFTI can be configured and programmed easily and quickly.

High-performance collaboration

SWIFTI offers a maximum Tool Center Point (TCP) speed of over 5 m/s,** 5 times faster than other 4 kg cobots and comparable with industrial robots. At 0.01 mm, SWIFTI also provides up to 10 times higher position repeatability than other collaborative robots.

Key features:

Collaborative safety

- Supervised by SafeMove and safety sensor
- Stop safely before contact with a human
- Interaction status light
- Safety certified Category 3, PL d

Easy to use

- Wizard easy programming
- Intuitive robot movement programming with external lead-through device
- SafeMove configurator App on the FlexPendant

Productivity

- With a TCP speed of over 5 m/s,** it is 5 times faster than other cobots in its class
- Up to 10 times higher position repeatability 0.01 mm than most cobots in its class
- Four integrated air supplies enable vacuum picking

Applications

- Assembly
- Insertion
- Kitting
- Material handling
- Machine tending
- Polishing
- Screw-driving
- And many more ...

* Safety PLC is required for connection with the laser scanner

** Safe collaborative speed may be lower, depending on your application layout. Always do a safety risk assessment of your cobot application.

Specification

Robot version	Reach (m)	Payload (kg)	Armload (kg)
CRB 1100-4/0.475	0.475	4	0.5
CRB 1100-4/0.58	0.58	4	0.5
Number of axes	6		
Protection	Standard IP40		
Mounting	Any angle		
Controller	OmniCore C30		
Integrated signal and power supply	Up to 12 signals (C1 + C2) on upper arm		
Integrated air supply	4 air on wrist (Max. 6 Bar)		
Integrated ethernet	One 1000 Base-T ethernet port (C2)		
Tool flange	Standard ISO 9409-1-31.5-4 M5		
Functional safety	SafeMove Collaborative included All safety functions certified to Category 3, PL d		

Performance (according to ISO 9283)

	CRB 1100-4/0.475	CRB 1100-4/0.58
Max TCP Velocity	4.32 m/s	5.05 m/s
Max TCP Acceleration (normal control motion @nominal load)	82.13 m/s ²	71.48 m/s ²
Max TCP Acceleration (e-stop @nominal load)	144.6 m/s ²	137.21 m/s ²
Acceleration time 0-1m/s	0.06 s	0.12 s
Pose repeatability, RP	0.01 mm	0.01 mm
1 kg picking cycle 25 × 300 × 25 mm	0.42 s	

Physical

Dimensions robot type	160 × 172 mm
Weight	21 kg

Movement

Axis movement	Working range	Max. speed CRB 1100-4/0.475	Max. speed CRB 1100-4/0.58
Axis 1 rotation	+230° to -230°	460°/s	460°/s
Axis 2 arm	+113° to -115°	380°/s	360°/s
Axis 3 arm	+55° to -205°	280°/s	280°/s
Axis 4 wrist	+230° to -230°	560°/s	560°/s
Axis 5 bend	+120° to -125°	420°/s	420°/s
Axis 6 turn	+400° to -400°	750°/s	750°/s



Working range, CRB 1100-4/0.475

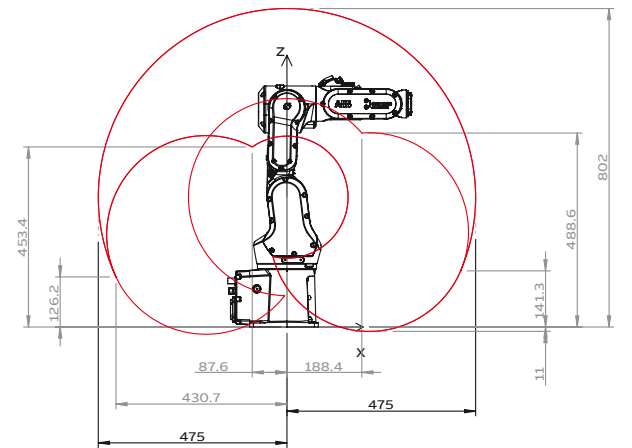

Working range, CRB 1100-4/0.58

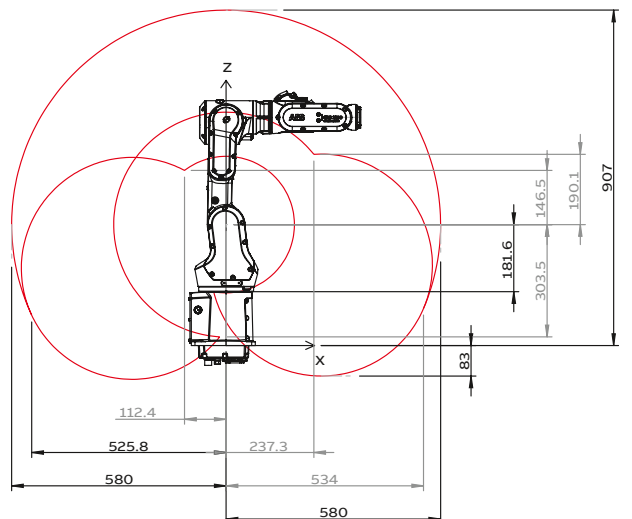

We reserve the right to make technical changes or modify the contents of this document without prior notice. With regard to purchase orders, the agreed particulars shall prevail. ABB does not accept any responsibility whatsoever for potential errors or possible lack of information in this document.

We reserve all rights in this document and in the subject matter and illustrations contained therein. Any reproduction, disclosure to third parties or utilization of its contents – in whole or in parts – is forbidden without prior written consent of ABB. Copyright© 2021 ABB
All rights reserved