

## IRB 930

# Unleash precision and speed with high payload SCARA robots



The IRB 930 is a 12-kg or 22-kg high payload SCARA robot that boosts throughput by up to 10% with class-leading speed, accuracy, internal cabling, and extraordinary downward force.

IRB 930 SCARA delivers high performance across all market segments, including electronics, automotive electrical vehicles (EV), solar, and fast-moving consumer goods (FMCG). IRB 930 is ideal for fast point-to-point applications, such as assembly, material handling, pick & place, and screw driving.

### High payload achieves more throughput by up to 10%

The IRB 930 is a 12-kg or 22-kg payload SCARA robot which provides higher payload capabilities than competing robots in its class. Capable of handling more objects in less time than other lighter payload SCARA robots, it can increase throughput by up to 10%. The high payload SCARA can also be used with sophisticated tools/grippers for delicate applications.

### Outstanding performance

The OmniCore controller offers best-in-class motion control through TrueMove and QuickMove alongside built-in digital connectivity and scalable functions.

The motion control delivers an impressive cycle time of 0.38 seconds, with a repeatability deviation position of only 0.01 mm. This performance empowers the IRB 930 to enhance hourly production rates while upholding high-quality manufacturing standards.

### Extraordinary downward force

IRB 930 offers a maximum downward force of 250N, providing more than double the average screw driving capacity of other robots on the market. This makes it ideally suited for not only conventional electronic applications but also green energy application areas like EV battery cells, modules, packs and solar panels.

### Omitting an external tube delivers up to 20% space saving

With all cables routed internally to remove cable interference, the IRB 930 saves up to 20% of the space typically required above the upper arm, optimizing production space and flexibility. This enables the IRB 930 to work nicely in close proximity to an inverted SCARA IRB 910INV or 6-axis robot.

### Larger diameter air hose provides up to 30% faster suction

The use of a larger diameter air hose provides additional power for vacuum suction, making it possible to simultaneously handle multiple objects up to 30% faster than other robots in its class.

### Increased connectivity

The option to include up to 20 I/O connectors allows more sophisticated grippers and end effectors to be used for more complex applications.

### Main applications

- Assembly
- Picking/Placing
- Material Handling
- Screw driving
- Packaging
- Testing

## Specification

Robot version	IRB 930-12/0.85	IRB 930-12/1.05	IRB 930-22/1.05
Reach (m)	0.85	1.05	1.05
Payload (kg)	12	12	22
Number of axes	4		
Protection	Standard IP30 <sup>1</sup>		
Mounting	Floor		
Controller	OmniCore C30, C90XT		
Integrated signal and power supply	Up to 20 signals <sup>2</sup>		
Integrated air supply	4 air on outer arm (Max. 6 Bar) <sup>2</sup>		
Integrated ethernet	One 1000 Base-T ethernet port <sup>2</sup>		
ESD compliance IEC 61340-5-1-2016 ANSI/ESD S20.20-2021			

<sup>1</sup> Ballscrew area: IP20

<sup>2</sup> Optional

## Performance

	IRB 930-12/0.85	IRB 930-12/1.05	IRB 930-22/1.05
2 kg picking cycle 25 x 300 x 25 mm	0.38 s	0.39 s	0.39 s
Axis 3 downforce <sup>3</sup>	250 N		

<sup>3</sup> Please check detail information from Product Specification

## Performance (according to ISO 9283)

Pose repeatability, RP	0.01 mm	0.02 mm	0.02 mm
Path repeatability, RT	0.05 mm	0.05 mm	0.04 mm
Pose stabilization time within 0.1mm of the position PSt	0.09s	0.18s	0.09s

Given motion pattern with optimized setup

## Physical and movement

	IRB 930-12/0.85	IRB 930-12/1.05	IRB 930-22/1.05
Robot Base	220 x 220 mm		
Robot weight	64 kg	66 kg	66 kg

## Working range

Axis 1 (rotation)	+145° to -145°
Axis 2 (rotation)	+145° to -145°
Axis 3 (Z)	-300 mm to 0 mm; -450 mm to 0 mm;
Axis 4 (rotation)	+400° to -400°

## Axis max. speed

Axis 1 (rotation)	410°/s	402°/s
Axis 2 (rotation)	534°/s	524°/s
Axis 3 (A)	2.24 m/s	
Axis 4 (rotation)	1702°/s	

[abb.com/robotics](http://abb.com/robotics)

We reserve the right to make technical changes or modify the contents of this document without prior notice. With regard to purchase orders, the agreed particulars shall prevail. ABB does not accept any responsibility whatsoever for potential errors or possible lack of information in this document.

## IRB 930, working range

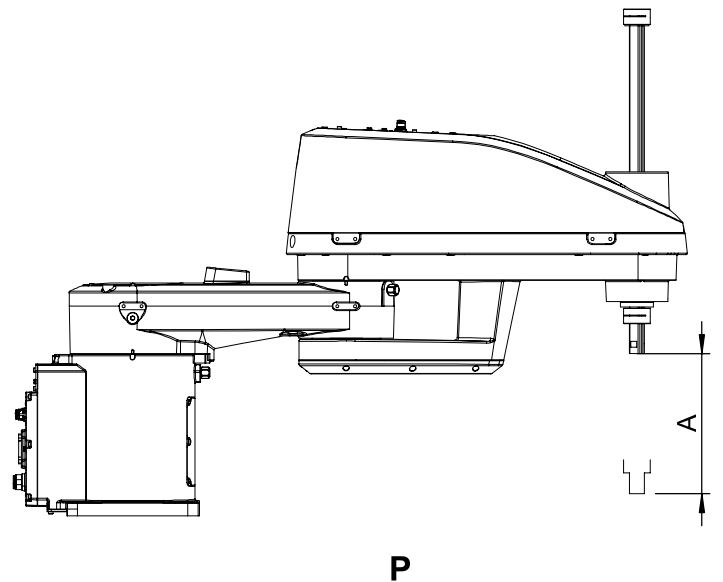
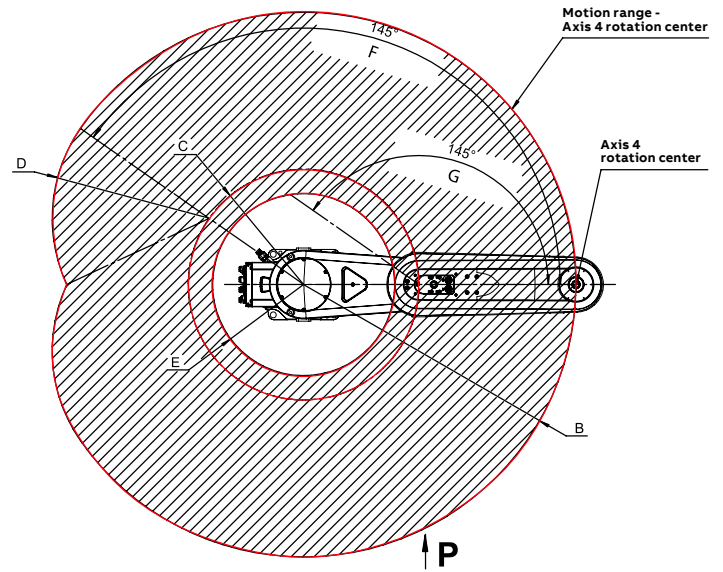

## Working range and dimension

	A(Axis 3)	B	C	D	E
<b>IRB 930</b>					
0.85_0.3	300 mm	850 mm	360 mm	490 mm	284.1 mm
0.85_0.45	450 mm	850 mm	360 mm	490 mm	284.1 mm
1.05_0.3	300 mm	1050 mm	560 mm	490 mm	322.7 mm
1.05_0.45	450 mm	1050 mm	560 mm	490 mm	322.7 mm

We reserve all rights in this document and in the subject matter and illustrations contained therein. Any reproduction, disclosure to third parties or utilization of its contents – in whole or in parts – is forbidden without prior written consent of ABB. Copyright© ABB All rights reserved