

Lubricant feed pump P203 for progressive systems

DC designs with control circuit board H

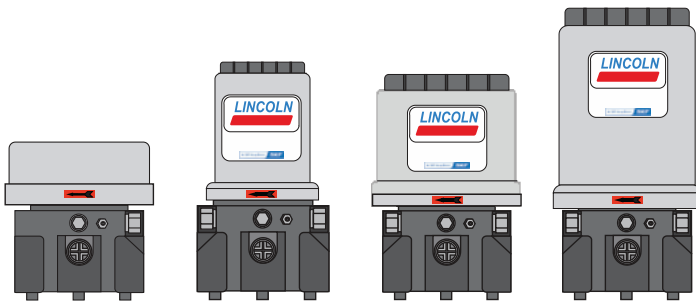

Created on: **12.12.2022**

Document no.: **951-171-028-EN**

Version: **03**



Read these instructions before installation or start-up of the product and keep them readily available for later consultation!

Original EC Declaration of Incorporation in accordance with Directive 2006/42/EC, Appendix II Part 1 B

The manufacturer hereby declares at its sole responsibility that the partly completed machinery conforms to the essential health and safety requirements of the Machinery Directive 2006/42/EC, Annex I, marked in the Annex to the EC Declaration of Incorporation as applicable and fulfilled at the time of placing on the market.

The special technical documents were prepared following Annex VII part B. Upon justifiable request, these special technical documents can be forwarded electronically to the respective national authorities. The authorized company for the compilation of the technical documentation is the manufacturer.

Designation: Electrically operated pump for the feeding of lubricants in interval operation inside a centralized lubrication system

Type: P203

Item number: 6440-xxxxxxx / 644-xxxxx-x / 94xxxxxx, 094xxxxxxx

Furthermore, the following directives and standards were applied in the respective applicable areas:

2011/65/EU: RoHS II

2014/30/EU: Electromagnetic Compatibility

EN ISO 12100:2010

EN 60204-1:2018

EN 61000-6-2:2005/AC:2005

EN 61000-6-4:2007/A1:2011

EN 61131-2:2007

EN 809:1998+A1:2009/AC:2010

EN 60034-1:2010/AC:2010

EN 60947-5-1:2004/A1:2009

EN 60947-5-2:2007/A1:2012

EN IEC 63000:2018

The partly completed machinery must not be put into service until it has been established that the machinery into which it is to be incorporated is in compliance with the provisions of the Machinery Directive 2006/42/EC and all other applicable Directives.

Walldorf, 21.05.2021

Jürgen Kreutzkämper

Manager, R&D

Germany

Manufacturer: SKF Lubrication Systems Germany GmbH, Heinrich-Hertz-Str. 2-8, 69190 Walldorf, Germany

Stefan Schürmann

Manager, PD

Germany South

Original UK Declaration of incorporation according to the Supply of Machinery (Safety) Regulations 2008 No. 1597 Annex II

The manufacturer hereby declares under sole responsibility that the partly completed machinery complies with the essential health and safety requirements of UK legislation Supply of Machinery (Safety) Regulations 2008 No. 1597 Annex I, marked in the Annex to the EC Declaration of Incorporation as applicable and fulfilled at the time of placing on the market.

The special technical documents were prepared following Annex VII part B. Upon justifiable request, these special technical documents can be forwarded electronically to the respective national authorities. The authorized company for the compilation of the technical documentation is SKF (U.K.) Limited, 2 Canada Close, Banbury, Oxfordshire, OX16 2RT, GBR.

Designation: Electrically operated pump for the feeding of lubricants in interval operation inside a centralized lubrication system

Type: P203

Item number: 6440-xxxxxxx / 644-xxxxx-x / 94xxxxxx, 094xxxxxxx

Furthermore, the following regulations and standards were applied in the respective applicable areas:

Supply of Machinery (Safety) Regulations 2008 No. 1597

• Electromagnetic Compatibility Ordinance 2016 No. 1091

• The Restriction of the Use of Certain Hazardous Substances in Electrical and Electronic Equipment Regulations 2012 No. 3032

EN ISO 12100:2010

EN 60204-1:2018

EN 61000-6-2:2005/AC:2005

EN 61000-6-4:2007/A1:2011

EN 61131-2:2007

EN 809:1998+A1:2009/AC:2010

EN 60034-1:2010/AC:2010

EN 60947-5-1:2004/A1:2009

EN 60947-5-2:2007/A1:2012

EN IEC 63000:2018

The partly completed machinery must not be put into service until it has been established that the machinery into which it is to be incorporated is in compliance with the provisions of UK legislation Supply of Machinery (Safety) Regulations 2008 No. 1597 and all other applicable Directives.

Walldorf, 21.05.2021

Jürgen Kreutzkämper

Manager, R&D

Germany

Manufacturer: SKF Lubrication Systems Germany GmbH, Heinrich-Hertz-Str. 2-8, 69190 Walldorf, Germany

Stefan Schürmann

Manager, PD

Germany South

Appendix to Declaration of Incorporation in accordance with 2006/42/EC, Annex II, No. 1 B

Description of the essential health and safety requirements according to 2006/42/EC, Annex I, which have been applied and fulfilled. Any essential health and safety requirements not listed here are not relevant to this product.

Table 1

Appendix to Declaration of Incorporation			
Valid for P2x3 lubrication pumps			
No.:	Essential health and safety requirement	Applicable:	Fulfilled:
1.1.1	Definitions	Yes	Yes
1.1.2	Principles of safety integration	Yes	Yes
1.1.3	Materials and products	Yes	Partially ¹⁾
1.1.5	Design of machinery to facilitate its handling	Yes	Yes
1.1.6	Ergonomics	Yes	Partially ²⁾
1.2	Control systems	Yes	Yes
1.2.1	Safety and reliability of control systems	Yes	Yes
1.2.3	Starting	Yes	Yes
1.2.6	Failure of the power supply	Yes	Yes
1.3	Protection against mechanical hazards	Yes	Yes
1.3.1	Risk of loss of stability	Yes	Yes
1.3.2	Risk of break-up during operation	Yes	Partially ³⁾
1.3.4	Risks due to surfaces, edges or angles	Yes	Yes
1.3.7	Risks related to moving parts	Yes	Yes
1.3.9	Risks of uncontrolled movements	Yes	Yes
1.5	Risks due to other hazards	Yes	Yes
1.5.1	Electricity supply	Yes	Yes
1.5.6	Fire	Yes	Yes
1.5.8	Noise	Yes	Yes
1.5.11	External radiation	Yes	Yes
1.5.13	Emissions of hazardous materials and substances	Yes	Yes
1.5.15	Risk of slipping, tripping, or falling	Yes	Yes
1.6	Servicing		
1.6.1	Machinery maintenance	Yes	Yes
1.6.2	Access to operating positions and servicing points	Yes	Partially ⁴⁾
1.6.4	Operator interventions	Yes	Yes
1.7	Information	Yes	Yes
1.7.1	Information and warnings on the machinery	Yes	Yes
1.7.1.1	Information and information devices	Yes	Yes
1.7.2	Warning of residual risks	Yes	Yes
1.7.3	Marking of machinery	Yes	Yes
1.7.4	Operating instructions/assembly instructions	Yes	Yes
1.7.4.1	General principles for the drafting of operating instructions/assembly instructions	Yes	Yes
1.7.4.2	Contents of the operating instructions/assembly instructions	Yes	Yes
1.7.4.3	Sales literature	Yes	Yes

- 1) Not completely fulfilled: Hazards due to the lubricant used must be assessed by the operator on the basis of the Safety Data Sheet (SDS) and, if necessary, protective measures must be taken.
- 2) Not completely fulfilled: The operator must ensure that the pump is integrated into the higher-level machine in such a way that the pump can be operated and filled ergonomically.
- 3) Not completely fulfilled: The operator must protect the lubrication system against excessive pressure. For this purpose, a pressure limiting valve with max. 350 bar opening pressure must be provided on each pump element.
- 4) Not completely fulfilled: The operator must ensure that the pump is integrated into the higher-level machine in such a way that the pump can be operated without danger.

Masthead

Manufacturer

SKF Lubrication Systems Germany GmbH
Email: Lubrication-germany@skf.com
www.skf.com/lubrication

Berlin Plant
Motzener Strasse 35/37
12277 Berlin
Germany
Tel. +49 (0)30 72002-0
Fax +49 (0)30 72002-111

Walldorf Plant
Heinrich-Hertz-Strasse 2-8
69190 Walldorf, Germany
Germany
Tel.: +49 (0) 6227 33-0
Fax: +49 (0) 6227 33-259

Authorized local distributors

- Great Britain -
SKF (U.K.) Limited,
2 Canada Close, Banbury, Oxfordshire,
OX16 2RT, GBR.

- North America -
SKF Lubrication Business Unit
Lincoln Industrial
5148 North Hanley Road, St. Louis,
MO. 63134 USA

- South America -
SKF Argentina Pte. Roca 4145,
CP 2001 Rosario, Santa Fe

Warranty

The instructions contain no statements regarding the warranty or liability for defects. That information can be found in our General Terms of Payment and Delivery.

Training

We conduct detailed training in order to enable maximum safety and efficiency. We recommend taking advantage of this training. For further information, contact your authorized SKF dealer or the manufacturer.

Table of contents

Masthead	4	4.7 Tightening torques.....	24
Table of contents.....	5	4.8 Type identification code.....	25
Safety alerts, visual presentation, and layout.....	7	4.8.1 Basic parameters and reservoir version.....	25
		4.8.2 Pump elements.....	27
		4.8.3 Voltage supply and electrical connections.....	28
		4.8.4 Control, lubricant, and additional specifications... ..	29
1. Safety instructions.....	8	5. Delivery, returns, storage.....	30
1.1 General safety instructions.....	8	5.1 Delivery.....	30
1.2 General electrical safety instructions.....	8	5.2 Return shipment.....	30
1.3 General behaviour when handling the product	9	5.3 Storage.....	30
1.4 Intended use.....	9	5.4 Storage temperature range	30
1.5 Persons authorized to use the product.....	9	5.5 Storage conditions for products filled with lubricant.....	30
1.6 Foreseeable misuse	9	5.5.1 Storage period up to 6 months	30
1.7 Referenced documents	10	5.5.2 Storage period between 6 and 18 months.....	30
1.8 Prohibition of certain activities	10	5.5.3 Storage period more than 18 months.....	30
1.9 Painting plastic components and seals.....	10	6. Assembly.....	31
1.10 Safety markings on the product	10	6.1 General safety instructions.....	31
1.11 Note on the type plate.....	11	6.2 Transporting the pumps.....	31
1.12 Notes on CE marking	11	6.3 Mechanical connection	32
1.13 Note on Low Voltage Directive.....	11	6.3.1 Minimum mounting dimensions	32
1.14 Note on Pressure Equipment Directive.....	11	6.3.2 Assembly holes.....	33
1.15 Note on UKCA marking.....	11	6.4 Electrical connections	33
1.16 Note on UL mark	11	6.5 Setting the delivery rate on pump element R.....	35
1.17 Note on ECE mark	11	6.6 Installing the pressure limiting valve	36
1.18 Notes on ADR certificate	11	6.7 Connection of the lubrication line.....	37
1.19 Note on EAC marking.....	12	6.8 Filling with lubricant.....	37
1.20 Note on China RoHS mark.....	12	6.8.1 Filling via the reservoir cover.....	37
1.21 Emergency shutdown	12	6.8.2 Filling via filler nipple.....	38
1.22 Assembly, maintenance, fault, repair.....	12	6.8.3 Filling via the optional fill connection	38
1.23 First start-up, daily start-up.....	12	6.9 Setting the lubrication time.....	39
1.24 Residual risks.....	13	6.9.1 Possible settings for lubrication time	39
2. Lubricants	14	7. First start-up	40
2.1 General information.....	14	7.1 Inspections before first start-up.....	40
2.2 Material compatibility	14	7.2 Inspections during first start-up.....	40
2.3 Temperature properties.....	14	8. Operation.....	41
2.4 Aging of lubricants	14	8.1 Top up lubricant	41
2.5 Avoidance of faults and hazards.....	14	9. Maintenance and repair	42
2.6 Solid lubricants	14	10. Cleaning	43
3. Overview, functional description.....	15	10.1 Basics.....	43
3.1 Pumps without a follower plate.....	15	10.2 Interior cleaning	43
3.2 Display and control elements.....	16	10.3 Exterior cleaning	43
3.2.1 Functional description of the control circuit board H	16	11. Faults, causes, and remedies.....	44
3.3 Electrical connections	17	11.1 Indication of operational and fault states by the LEDs on the control circuit board.....	45
3.4 Hydraulic connection diagram	18	12. Repairs	46
4. Technical data	19	12.1 Replacing pump element and pressure limiting valve..	46
4.1 General technical data.....	19	12.2 Replacing the control circuit board.....	47
4.1.1.....	19	13. Shutdown, disposal.....	48
4.2 Electrical data.....	20	13.1 Temporary shutdown.....	48
4.3 Nominal delivery rates	20	13.2 Permanent shutdown, disassembly	48
4.3.1 Influencing factors on the delivery rate	21	13.3 Disposal.....	48
4.3.2 Delivery rate charts for typical NLGI 2 lubricants	21	14. Spare parts.....	49
4.4 Reservoir versions.....	22	14.1 Housing cover, complete	49
4.5 Usable reservoir volume	23	14.2 Pump elements	49
4.5.1 Usable reservoir volume for reservoirs without a follower plate.....	23	14.3 Pressure limiting valves and adapters.....	49
4.6 Lubricant volume when an empty pump is filled for the first time.....	24	14.4 Adapter D6 AX 1/8NPT I C.....	50
		14.5 Adapter with lubricant nipple	50

14.6 Plug screw M22x1.5.....	50
14.7 Motor 12 / 24 VDC.....	50
14.8 Replacement kit for control circuit board	51
14.9 Transparent reservoir	51
14.10 Fixed paddle.....	51
14.11 Reservoir cover	52
14.12 Screw cap.....	52
14.13 Connection sockets and cables.....	52
15. Appendix.....	53
15.1 Connection diagrams.....	53
15.1.1 Overview of cables and possible connections	53
15.1.2 Terminal diagram P203 VDC, with control circuit board H and rectangular connector	54
15.1.3 Terminal diagram P203 VDC, with control circuit board H and bayonet connector.....	55
15.2 China RoHS Table	56

Safety alerts, visual presentation, and layout

While reading these instructions, you will encounter various symbols, illustrations, and text layouts intended to help you navigate and understand the instructions. Their meaning is explained below.

Safety alerts:

Activities that present specific hazards (to life and limb or possible damage to property) are indicated by safety alerts. Always be sure to follow the instructions given in the safety alerts.

DANGER

These safety alerts indicate an imminent danger. Ignoring them will result in death or serious injury

WARNING

These safety alerts indicate potentially imminent danger. Ignoring them could result in death or serious injury

CAUTION

These safety alerts indicate potentially imminent danger. Ignoring them could result in minor injury

NOTICE

These safety alerts indicate a potentially harmful situation. Ignoring them could result in damage to property or malfunctions

Illustrations:

The illustrations used depict a specific product. For other products, they may have the function of a diagram only. This does not alter the basic workings and operation of the product.

Text layout:

- **First-order bulleted lists:** Items on a bulleted list start with a solid black dot and an indent.
 - **Second-order bulleted lists:** If there is a further listing of subitems, the second-order bulleted list is used.
- 1 **Legend:** A legend explains the numbered contents of an illustration, presented as a numbered list. Items in a legend start with a number (with no dot) and an indent.
 - **Second-order legend:** In some cases, the numbered contents of an image represent more than just one object. A second-order legend is then used.

1. Instruction steps: These indicate a chronological sequence of instruction steps. The numbers of the steps are in bold and are followed by a period. If a new activity follows, the numbering starts again at “1.”

- **Second-order instruction steps:** In some cases, it is necessary to divide up a step into a few substeps. A sequence of second-order instruction steps is then used.

1. Safety instructions

1.1 General safety instructions

- Putting the products into operation or operating them without having read the instructions is prohibited. The operator must ensure that the instructions are read and understood by all persons tasked with working on the product or who supervise or instruct such persons. Retain the instructions for further use.
- The product may only be used in awareness of the potential dangers, in proper technical condition, and according to the information in this manual.
- Any faults that could affect safety must be remedied according to responsibility. The supervisor must be notified immediately in case of malfunctions outside one's individual scope of responsibility.
- Unauthorized modifications and changes can have an unpredictable effect on safety and operation. Unauthorized modifications and changes are therefore prohibited. Only original SKF spare parts and SKF accessories may be used.
- Any unclear points regarding proper condition or correct assembly/operation must be clarified. Operation is prohibited until issues have been clarified.
- The components used must be suitable for the intended use and the applicable operating conditions, e.g. max. operating pressure and ambient temperature range, and must not be subjected to torsion, shear, or bending.

1.2 General electrical safety instructions

- Electrical devices must be kept in proper condition. This must be ensured by periodic inspections in accordance with the relevant applicable standards and technical rules. The type, frequency, and scope of the inspections must be determined in accordance with the risk assessment to be carried out by the operator. Work on electrical components may be performed only by qualified electricians. Connect the electrical power only in accordance with the valid terminal diagram and in observance of the relevant regulations and the local electrical supply conditions.
- Work on electrical components may be performed only in a voltage-free state and using tools suitable for electrical work. Do not touch cables or electrical components with wet or moist hands.
- Fuses must not be bridged. Always replace defective fuses with fuses of the same type.
- Ensure proper connection of the protective conductor for products with protection class I. Observe the specified enclosure rating.
- The operator must implement appropriate measures to protect vulnerable electrical devices from the effects of lightning during use. The electrical device is not furnished with a grounding system for the dissipation of the respective electric charge and does not have the voltage strength necessary to withstand the effects of lightning.

1.3 General behaviour when handling the product

- Familiarize yourself with the functions and operation of the product. The specified assembly and operating steps and their sequences must be observed.
- Keep unauthorized persons away.
- Wear personal protective equipment always.
- Precautionary operational measures and instructions for the respective work must be observed.
- In addition to these Instructions, general statutory regulations for accident prevention and environmental protection must be observed.
- Precautionary operational measures and instructions for the respective work must be observed. Uncertainty seriously endangers safety.
- Safety-related protective and safety equipment must not be removed, modified or affected otherwise in its function and is to be checked at regular intervals for completeness and function.
- If protective and safety equipment has to be dismantled, it must be reassembled immediately after finishing the work, and then checked for correct function.
- Remedy occurring faults in the frame of responsibilities. Immediately inform your superior in the case of faults beyond your competence.
- Never use parts of the centralized lubrication system or of the machine as standing or climbing aids.

1.4 Intended use

Supply of lubricants.

The product is intended solely for installation in another machine.

Use is only permitted within the scope of commercial or economic activity by professional users, in compliance with the specifications, technical data, and limits specified in this manual.

1.5 Persons authorized to use the product

Operator

A person who is qualified by training, knowledge and experience to carry out the functions and activities related to normal operation. This includes avoiding possible hazards that may arise during operation.

Specialist in electrics

Person with appropriate professional education, knowledge and experience to detect and avoid the hazards that may arise from electricity.

Specialist in mechanics

Person with appropriate professional education, knowledge and experience to detect and avoid the hazards that may arise during transport, installation, start-up, operation, maintenance, repair and disassembly.

1.6 Foreseeable misuse

Any usage of the product other than as specified in this manual is strictly prohibited. Particularly prohibited are:

- Use of non-specified consumables, contaminated lubricants, or lubricants with air inclusions.
- Use of C3 versions in areas with aggressive, corrosive substances (e.g., high salt load).
- Use of plastic parts in areas with high exposure to ozone, UV light, or ionizing radiation.
- Use to supply, convey, or store hazardous substances and mixtures as defined in the CLP Regulation (EC 1272/2008) or GHS with acute oral, dermal, or inhalation toxicity or substances and mixtures that are marked with hazard pictograms GHS01-GHS06 and GHS08.
- Use to supply, convey, or store Group 1 fluids classified as hazards as defined in the Pressure Equipment Directive (2014/68/EU) Article 13 (1) a).
- Use to supply, convey, or store gases, liquefied gases, dissolved gases, vapors, or fluids whose vapor pressure exceeds normal atmospheric pressure (1013 mbar) by more than 0.5 bar at their maximum permissible operating temperature.
- Use in an explosion protection zone.
- Use without proper securing against excessively high pressures, in the case of pressurized products.
- Use outside of the technical data and limits specified in this manual.

1.7 Referenced documents

In addition to this manual, the following documents must be observed by the respective target group:

- Company instructions and approval rules

If applicable:

- Safety data sheet of the lubricant used
- Project planning documents
- Supplementary information regarding special designs of the pump. This you will find in the special system documentation.
- Instructions for other components for setting up the centralized lubrication system.



1.8 Prohibition of certain activities

- Replacement of or modifications to the pistons of the pump elements
- Repairs or modifications to the drive
- Alterations to the control circuit board beyond adjustment of lubrication times and interval times or replacement in case of defect

1.9 Painting plastic components and seals

The painting of any plastic components and seals of the products described is prohibited. Completely mask or remove plastic components before painting the main machine.

1.10 Safety markings on the product

	Risk of wrapping, pinching, crushing, or shearing when the reservoir lid is open (only for reservoirs with filling from above)
	Direction of rotation of the pump (stirring paddle)

Possible safety markings on the product

NOTE

Further to the findings of the workplace risk evaluation the operating company has to attach additional markings (e. g. warnings, signs giving orders, prohibition signs or labelling as specified by CLP / GHS), where appropriate.

1.11 Note on the type plate

The type plate provides important data such as the type designation, order number, and sometimes regulatory characteristics. To avoid loss of this data in case the type plate becomes illegible, it should be entered in the manual.

Table 2	
Table for copying out the type plate	
Model:	_____
P-No. :	_____
S-No. :	_____

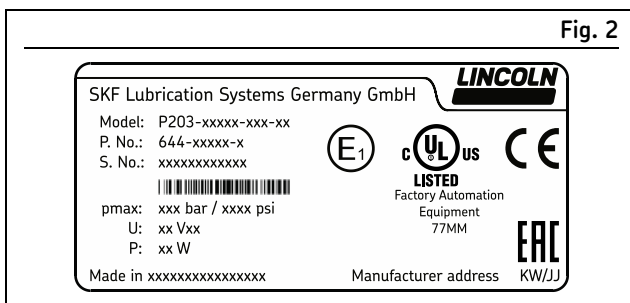

Type plate VDC with E1 and UL certification

1.12 Notes on CE marking



CE marking is effected following the requirements of the applied directives requiring a CE marking:

- 2014/30/EC Electromagnetic Compatibility
- 2011/65/EU Directive on the restriction of the use of certain hazardous substances in electrical and electronic equipment (RoHS II)

1.13 Note on Low Voltage Directive

The protection objectives of the Low Voltage Directive 2014/35/EU are met in accordance with Annex I, No. 1.5.1 of the Machinery Directive 2006/42/EC.

1.14 Note on Pressure Equipment Directive

Due to its performance characteristics, the product does not reach the limit values defined in Article 4, Paragraph 1, Subparagraph (a) (ii) and is excluded from the scope of Pressure Equipment Directive 2014/68/EU in accordance with Article 1, Paragraph 2 Subparagraph (f).

1.15 Note on UKCA marking



The UKCA conformity marking confirms the product's conformity with the applicable legal provisions of Great Britain.

1.16 Note on UL mark



The UL Mark certifies that the product has UL certification of compliance with U.S. and Canadian safety regulations.

1.17 Note on ECE mark



The ECE test mark (E1) confirms that an ECE type approval (components requiring approval on motor vehicles) has been granted for a product which bears this mark on its type plate.

1.18 Notes on ADR certificate



Pumps with ADR certification are marked with the sign shown here.

The use of the lubricant feed pumps described meets the ADR requirements for the utilization of the ADR connection materials specified in the type identification code and for the correct performance of electrical assembly outside of potentially explosive atmospheres in Zones 0, 1 or 2 in vehicle types EX/II, EX/III, FL and AT.

Testing institute: TÜV-SÜD Auto Service GmbH

Component marking: TÜ.EGG.054-01

1.19 Note on EAC marking



The EAC conformity marking confirms the product's conformity with the applicable legal provisions of the Eurasian customs union.

1.20 Note on China RoHS mark



The China RoHS mark confirms that there is no danger to persons or the environment from the regulated substances contained within for the intended period of use (year number shown in the circle).

1.21 Emergency shutdown

This is done by a course of action to be defined by the operator.

1.22 Assembly, maintenance, fault, repair

Prior to the start of this work, all relevant persons must be notified of it. At a minimum, the following safety measures must be taken before any work is done:

- Unauthorized persons must be kept away
- Mark and secure the work area
- Cover adjacent live parts
- Dry any wet, slippery surfaces or cover them appropriately
- Cover hot or cold surfaces appropriately

Where applicable:

- Depressurize
- Isolate, lock and tag out
- Check to ensure live voltage is no longer present
- Ground and short-circuit

The product should be protected as much as possible from humidity, dust, and vibration, and should be installed so that it is easily accessible. Ensure an adequate distance from sources of heat or cold. Any visual monitoring devices present, such as pressure gauges, min./max. markings, or oil level gauges must be clearly visible. Observe the mounting position requirements.

Drill required holes only on non-critical, non-load-bearing parts of the operator's infrastructure. Use existing holes where possible. Avoid chafe points. Immobilize any moving or detached parts during the work. Adhere to the specified torques.

If guards or safety devices need to be removed, they must be reinstalled immediately following conclusion of work and then checked for proper function.

Check new parts for compliance with the intended use before using them.

Avoid mixing up or incorrectly assembling disassembled parts. Label parts. Clean any dirty parts.

1.23 First start-up, daily start-up

Ensure that:

- All safety devices are fully present and functional
- All connections are properly connected
- All parts are correctly installed
- All warning labels on the product are fully present, visible, and undamaged
- Illegible or missing warning labels are immediately replaced

1.24 Residual risks

Table 3

Residual risks		
Residual risk	Possible in lifecycle	Avoidance / Remedy
Personal injury / property damage due to falling of hoisted parts	A B C G H K	<ul style="list-style-type: none"> Unauthorized persons must be kept away. Personnel are not permitted to stand under hoisted parts. Lift parts using suitable lifting gear.
Personal injury / property damage due to tilting or falling product due to non-compliance with specified torques	B C G	<ul style="list-style-type: none"> Adhere to the specified torques. Mount the product only on components with a sufficient load-carrying capacity. If no torques are specified, use those specified for the screw size for screws of strength class 8.8.
Personal injury / property damage caused by electric shock resulting from power lead damage	B C D E F G H	<ul style="list-style-type: none"> Inspect power cables for damage prior to initial use and then at regular intervals. Do not install the cable on moving parts or wearing spots. If this cannot be avoided, use anti-kink coils and/or conduits.
Personal injury, property damage due to spilled, leaked lubricant	B C D F G H K	<ul style="list-style-type: none"> Be careful when filling the reservoir and then connecting or disconnecting the lubricant lines. Use only hydraulic screw unions and lubrication lines suitable for the specified pressure. Do not install lubrication lines on moving parts or chafe points. If this cannot be avoided, use anti-kink coils and/or conduits.
Loss of electrical protective function due to incorrect assembly of the electrical components after a repair	G	<ul style="list-style-type: none"> An electrical safety check in accordance with EN 60204-1 must be performed after the replacement of electrical components.
Reservoirs with a follower plate are under spring tension	G	<ul style="list-style-type: none"> Wait until tension has been relieved on the spring as much as possible (i.e., the reservoir is empty) before removing a reservoir with a follower plate. Provide a suitable protective measure when loosening the reservoir, e.g., a retaining strap. Do not work with your head directly above the reservoir.
Risk of injury from pinching, crushing, or shearing through contact with the agitator blade when the pump is running and the reservoir lid is open.	B C D E F G	<ul style="list-style-type: none"> Never reach into the reservoir when the pump is running. Do not remove the reservoir lid unless the pump is first disconnected from the power supply.

Lifecycle phases: A = Transport, B = Assembly, C = First start-up, D = Operation, E = Cleaning, F = Maintenance, G = Malfunction, repair, H = Shutdown, K = Disposal

2. Lubricants

2.1 General information

Lubricants are selected specifically for the relevant application. The manufacturer or operator of the machine should ideally make the selection in consultation with the supplier of the lubricant. If you have no or little experience in selecting lubricants for lubrication systems, please contact us. We would be happy to assist you in selecting suitable lubricants and components to build a lubrication system optimized for your particular application. Consider the following points when selecting/using lubricants. This will spare you potential downtime and damage to the machine or lubrication system.

2.2 Material compatibility

The lubricants must generally be compatible with the following materials:

- Plastics: ABS, CR, FPM, NBR, NR, PA, PET, PMMA, POM, PP, PS, PTFE, PU, PUR
- Metals: steel, gray cast iron, brass, copper, aluminum

2.3 Temperature properties

The lubricant used must be suitable for the specific ambient temperature of the product. The viscosity approved for proper functioning must neither be exceeded at low temperatures nor fall too low at high temperatures. For the approved viscosity, see the "Technical data" chapter.

2.4 Aging of lubricants

Based on past experience with the lubricant used, checks should be conducted at regular intervals defined by the operator, to determine whether the lubricant needs to be replaced due to aging processes (oil separation). In case of doubt regarding the continued suitability of the lubricant, it must be replaced before the system is started up again. If you do not yet have any experience with the lubricant used, we recommend conducting a check after just one week.

2.5 Avoidance of faults and hazards

To avoid faults and hazards, please observe the following:

- When handling lubricants, observe the relevant safety data sheet (SDS) and any hazard labeling on the packaging.
- Due to the large number of additives, some lubricants that meet the pumpability requirements specified in the manual are not suitable for use in centralized lubrication systems.
- Whenever possible, always use SKF lubrication greases. They are ideal for use in lubrication systems.
- Do not mix lubricants. This can have unpredictable effects on the properties and usability of the lubricant.
- Use lubricants containing solid lubricants only after technical consultation with SKF.

- The lubricant's ignition temperature has to be at least 50 kelvin above the maximum surface temperature of the components.

2.6 Solid lubricants

Solid lubricants may only be used after prior consultation with SKF. When solid lubricants are used in lubrication systems, the following rules generally apply:

Graphite:

- Maximum graphite content 8%
- Maximum grain size 25 µm (preferably in lamellar form)

MoS₂:

- Maximum MoS₂ content 5%
- Maximum grain size 15 µm

Copper:

- Lubricants containing copper are known to lead to coatings forming on pistons, bore holes, and mating surfaces. This can result in blockages in the centralized lubrication system.

Calcium carbonate:

- Lubricants containing calcium carbonate are known to lead to very heavy wear on pistons, bore holes, and mating surfaces.

Calcium hydroxide:

- Lubricants containing calcium hydroxide are known to harden considerably over time, which can lead to failure of the centralized lubrication system.

PTFE, zinc, and aluminum:

- For these solid lubricants, it is not yet possible to define any limit values for use in lubrication systems on the basis of existing knowledge and practical experience.

3. Overview, functional description

3.1 Pumps without a follower plate



Fig. 3

P203 without a follower plate

- 1 Reservoir cover
- 2 Reservoir ventilation
- 3 Reservoir
- 4 Filler nipple
- 5 Pump housing
- 6 Pump elements
- 7 Stirring paddle

Reservoir

The reservoir stores the lubricant. Different reservoir designs and reservoir sizes exist in accordance with the pump variant.

Reservoir cover

Is used to fill the reservoir with clean and suitable lubricant, and also to protect the lubricant from contamination.

Reservoir ventilation

Aerates the reservoir while the pump is working and lubricant is being fed.

Stirring paddle

The stirring paddle homogenizes and smooths the lubricant while the pump is running. In addition, the lower vertical part of the stirring paddle presses the lubricant in the direction of the pump elements and improves the suction characteristics of the pump as a result.

Pump housing

The pump housing contains the motor, the electrical connections, the filler nipple, the pump elements, the power supply board and (if applicable) the intermittent low-level signal.

Pump elements

The pump can be equipped with up to 3 pump elements.

Filler nipple

Used for filling the pump from below. Once the filler nipple is removed, corresponding accessories can be used to connect the external grease return from the pressure limiting valves to the pump elements through this port.

3.2 Display and control elements

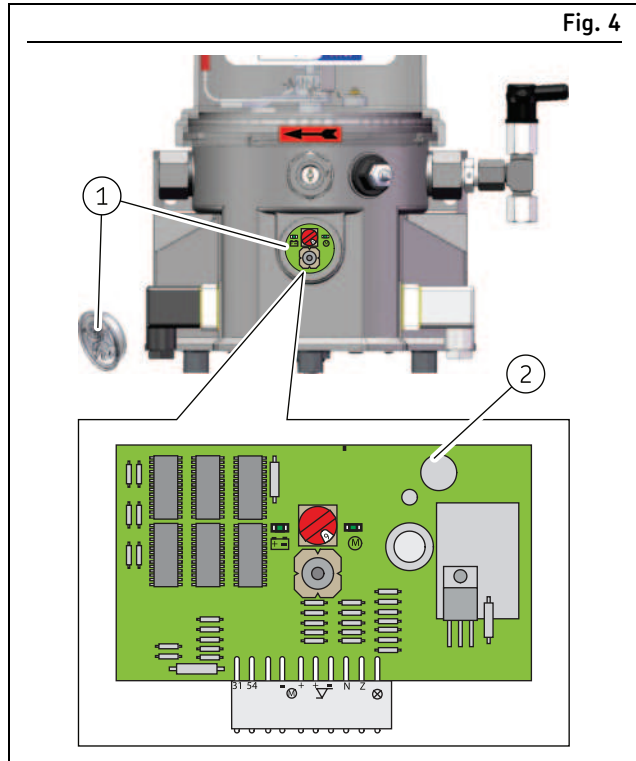

Display and control elements of the control circuit boards

- 1 Screw cap
- 2 Control circuit board H

Screw cap for control circuit board

The transparent screw cap allows viewing of the LED indicators (of operational and fault states) on the control circuit board. The control elements (rotary switch for setting the time, button for fault acknowledgment and additional lubrication) can be accessed by removing the screw cap.

Control circuit board

The control circuit board is located behind the threaded closure mechanism.

3.2.1 Functional description of the control circuit board H

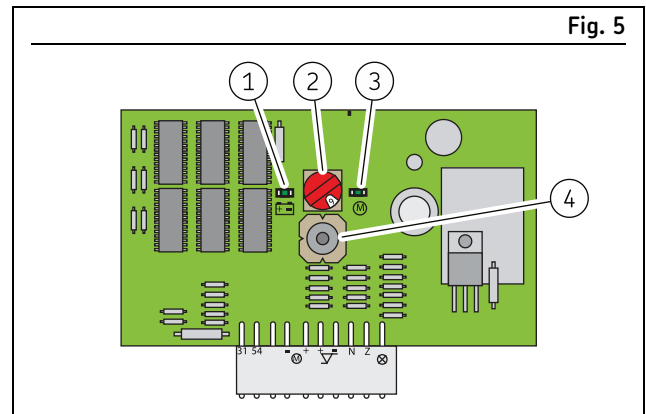

Control circuit board H

- 1 LED for power supply
- 2 Rotary switch for lubrication
- 3 LED for operation/fault
- 4 Pushbutton for additional lubrication

Control circuit board H is used to control P203 lubrication pumps on vehicle trailers without permanent voltage supply. Activation of control circuit board H is effected by the first braking of the vehicle after it has been switched on. There is a capacitor on the circuit board that safeguards the power supply to the control circuit board.

Principle of operation

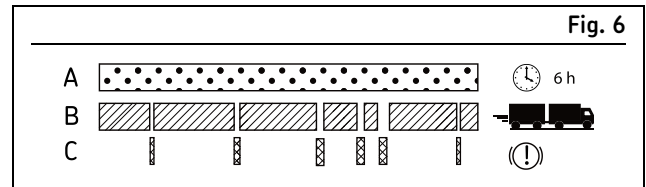

Functional sequence

Table 4		
Functional sequence		
A	Availability time	6 h (unchangeable)
B	Pause time (travel time)	5 h 30 min. 5 h 58 min.
C	Lubrication time (Braking)	30 min. 2 min.

The capacitor on control circuit board H is charged every time the vehicle brake is actuated by the supply voltage of the brake light. The necessary supply voltage of the control circuit board for saving the interval and lubrication time and for the function of the shock sensor is secured for 4 to 5 days (discharge time of the capacitor).

If the vehicle is traveling, then this will be detected by the shock sensor and the unchangeable availability time (A) and the variable pause time (B) will expire.

The pause time (B) for the duration of the standstill will be stopped for each vehicle standstill period. Standstill times are not added to the availability time (A).

A lubrication is carried out for the duration of each brake application until the lubrication time set on the control circuit board (C) has been reached. No further lubrications are carried out afterwards during brake applications.

After 6 hours, the pump ends the availability time (A) and starts a new cycle.

NOTE

During downtimes which are longer than the discharge time of the capacitor, the saved pause time that has already expired is lost.

The pause time starts again from the beginning when the brake is actuated once again. This is to be taken into account with vehicle trailers which are moved only briefly and then remain at a standstill for prolonged periods afterwards. Additional lubrications may be necessary in such cases.

3.3 Electrical connections

Fig. 7





Electrical connections of the P203

- 1 Power supply (rectangular connector)
- 2 Power supply (bayonet connector)

Table 5

Possible versions of the electrical connections

- 1  Rectangular connector 3 + PE acc. to DIN EN 175301-803
- 2  Bayonet connector, 4-pin, acc. to ISO 15170-1

NOTE

The design and arrangement of the electrical connections depend on the pump version ordered.

3.4 Hydraulic connection diagram

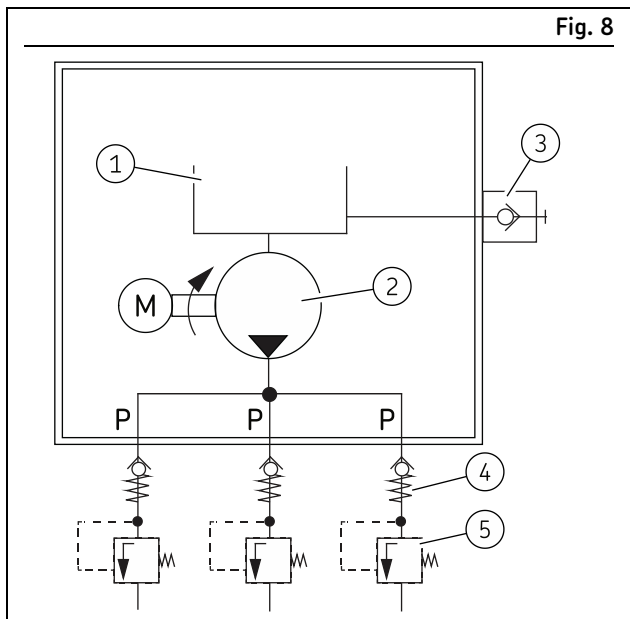

Hydraulic connection diagram of the pump

- | | |
|-----------------|---------------------------|
| 1 Reservoir | 4 Check valve |
| 2 Pump | 5 Pressure limiting valve |
| 3 Filler nipple | P Pressure line |

4. Technical data

4.1 General technical data

Table 6

Technical data	
Parameter	Values
Operating pressure	max. 350 bar [5076 psi]
Pump elements	Max. 3
Direction of rotation	Clockwise
Sound pressure level	< 70 dB (A)
Nominal speed	20 rpm
Cyclic duration factor ¹⁾	S3 25 ON time 120 min
Ambient temperature ¹⁾	-40 °C to +70 °C [-40 °F to +158 °F]
Mounting position ²⁾	Upright, i.e., with the reservoir at top
Lubricants ³⁾	<ul style="list-style-type: none"> Lubricating greases up to and including NLGI 2
Filling options	Depends on the pump design: <ul style="list-style-type: none"> Filler nipple Reservoir cover (with reservoirs without a follower plate) Optional fill connection

¹⁾ The specified ambient temperature range requires that the lubricant used can be pumped at the given ambient temperature. The upper limit of the ambient temperature is load-dependent and is determined primarily by the running time and the operating pressure. The cyclic duration factor specified is applicable for NLGI 2 lubricants, an ambient temperature of 60 °C [140 °F], and a mean back pressure on the pump element of 160 bar [2321 psi]. The maximum ON time should be reduced in the case of temperatures ≥ 60 °C [140 °F] and heavy loading (meaning higher pressure). UL-certified pumps can only be operated up to a maximum permissible ambient temperature of 60 °C [140 °F] regardless of the loading.

²⁾ If an inclined position is expected (e.g. on construction or agricultural equipment), the following applies:

- The maximum filling must be reduced in accordance with the inclination to be expected (< MAX mark).
- The minimum fill level must be increased if the expected inclination is > 30° or more, otherwise functioning could be impaired due to a reduced amount of lubricant in the suction area of the pump.

³⁾ Observe the restrictions in the section "Operational limits of the intermittent empty signal".

Table 7

Weight of the empty pump			
Reservoir size			
2 liter	[0.53 gal.]	Approx. 6.5 kg	[14.3 lbs.]
4 liter	[1.06 gal.]	Approx. 7.4 kg	[16.3 lbs.]
8 liter	[2.11 gal.]	Approx. 8.5 kg	[18.7 lbs.]

4.2 Electrical data

Table 8

Electrical data		
Parameter	Values	
	12 VDC pump	24 VDC pump
Enclosure rating ¹⁾	IP6K9K	IP6K9K
Protection classes		
• Rectangular connector	SELV / PELV / FELV	SELV / PELV / FELV
• Bayonet connector	SELV / PELV	SELV / PELV
Rated voltage ±10 %	12 VDC	24 VDC
Current input up to	6 A	3 A
Recommended back-up fuse	6.0 A (slow)	3.0 A (slow)
Output signal		
• Switching capacity, max.	72 VA	72 VA
• Switching voltage, max.	30 VDC	30 VDC
• Switched current, max.	700 mA	700 mA

¹⁾ The specified enclosure rating of the pump requires the use of IP6K9K-capable connection sockets and corresponding cables. Classification is in accordance with the lowest enclosure rating when connection sockets and cables with low type of protection are used. The achievable types of protection when using the connection sockets and cable which we supply can be found in the "Spare parts" chapter.

4.3 Nominal delivery rates

NOTE

The specified nominal delivery rates per stroke apply to NLGI grade 2 lubrication greases in the case of pump elements 5, 6, 7, and R and to NLGI grade 0 lubrication greases in the case of pump element L, in all cases at an ambient temperature of +20 °C [68 °F] and a back pressure of 100 bar [1450 psi] at the pump element.

Differences in operating conditions or a different pump configuration will lead to changes in the motor speed and thus to a change in the delivery rate per unit of time. If the change in the motor speed necessitates an adjustment to the delivery rate per unit of time, then this will be reasonably accomplished by adjusting the lubrication and pause time setting of the pump.

Table 9

Nominal delivery rate per stroke						
Pump element	L ¹⁾	5	6	7	R	B
Nominal delivery rate per stroke	0.03 ccm	0.10 ccm	0.16 ccm	0.22 ccm	0.04 - 0.18 ccm	0.10 ccm

¹⁾ With pump element L, lubricants below NLGI grade 2 can be pumped without restriction as specified in these instructions. For lubricants of NLGI grade 2, the suitability of the pump element L for temperatures of -5 °C or lower must be checked on a case-by-case basis.

4.3.1 Influencing factors on the delivery rate

Table 10

Influencing factors on the delivery rate		
Influencing factors	Increasing the delivery rate	Reducing the delivery rate
Ambient temperature	> + 20 °C	< + 20 °C
Consistency class of the lubricating grease	< NLGI 2	N/A
Number of pump elements	N/A	> 1
Back pressure at the pump element	< 100 bar	> 100 bar

4.3.2 Delivery rate charts for typical NLGI 2 lubricants

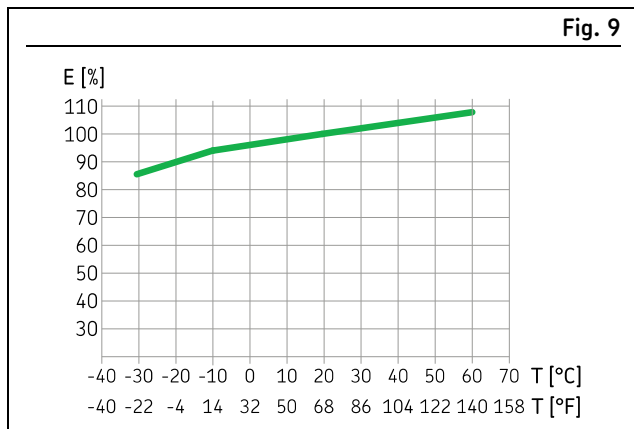

Delivery rate chart for low-temperature grease

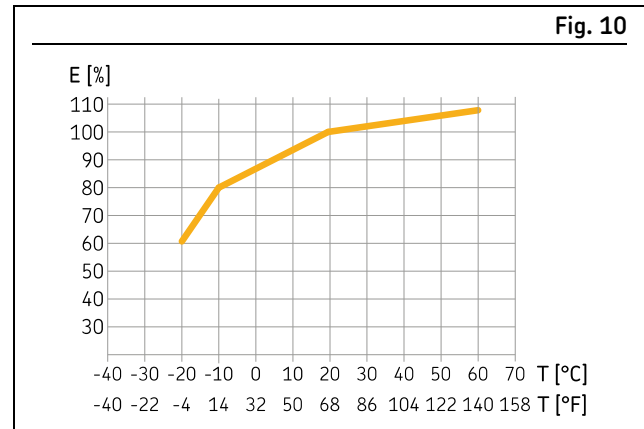

Delivery rate chart for high-temperature grease

NOTE

The values specified in the delivery rate charts represent the average value between different high-temperature and low-temperature greases. The values could therefore vary with the lubrication grease actually used in the pump. This may need to be borne in mind when designing the lubrication system.

Calculation of temperature-dependent delivery rate, using a high-temperature grease as an example

$$OUT = RPM \times V \times E$$



- OUT* Calculated delivery rate per pump element (ccm/min)
- RPM* Nominal speed of the pump (in this example: $RPM = 20 \text{ rpm}$)
- V* Nominal delivery rate per pump element (in this example: $V = 0.22 \text{ ccm/stroke}$)
- E* Efficiency as a percentage (in this example: $E = 80\%$) at a temperature of $T = -10 \text{ °C}$

$$OUT = 20 \frac{1}{min} \times 0,22 \text{ ccm} \times 80 \% = 3,5 \frac{ccm}{min}$$

4.4 Reservoir versions

The possible reservoir versions for the pumps described in these instructions can be found below (see also the type identification code). To improve the clarity of the illustrations, only the smallest possible reservoir size is shown in each case. The differences between the reservoir versions may not be visible in the illustrations, as the differences lie in the internal structure (e.g. with and without low-level signal).

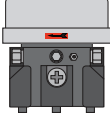
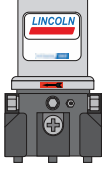
(● = available reservoir sizes)

Table 11									
P203 reservoir versions									
XNFL					XN				
2*	4	8	11	15	2	4*	8*	11*	15*
[0.53]	[1.06]	[2.11]	[2.9]	[3.96]	[0.53]	[1.06]	[2.11]	[2.9]	[3.96]
●	—	—	—	—	●	—	—	—	—
									
XNBO									
2	4*	8*	11*	15*					
[0.53]	[1.06]	[2.11]	[2.9]	[3.96]					
—	●	●	—	—					
									

* With these reservoir sizes, the installation of a pressure limiting valve in the pump element requires the adapter 226-14105-5.

4.5 Usable reservoir volume

NOTE

The usable reservoir volume in the reservoir design without follower plate is strongly dependent on the consistency (NLGI Grade) of the lubricant used and the ambient temperature. With high consistency and a low working temperature, more lubricant typically adheres to the inner surfaces of the reservoir and the pump, leaving less lubricant available for feeding.

Table 12

4.5.1 Usable reservoir volume for reservoirs without a follower plate

Reservoir size in liters and [gal.]	2 [0.53]	4 [1.06]	8 [2.11]
Lubricants with relatively low consistency ¹⁾ ²⁾	1.6 - 2.0 [0.42 - 0.53]	3.35 - 3.85 [0.88 - 1.01]	6.65 - 7.15 [1.76 - 1.88]
Lubricants with relatively high consistency ³⁾	1.8 - 2.0 [0.47 - 0.53]	3.65 - 4.15 [0.96 - 1.10]	7.00 - 7.50 [1.84 - 1.98]

¹⁾ Consistencies of NLGI 000 lubricants at + 60 °C [140 °F] up to consistencies of NLGI 1.5 lubricants at + 20 °C [68 °F].

²⁾ Consistencies of NLGI 2 lubricants at + 20 °C [68 °F] up to the maximum permissible lubricant consistency.

³⁾ When using lubricants with relatively low consistency in pumps subjected to strong vibrations or tilting motions (e.g., heavy equipment for construction or agriculture), maintain a clearance of about 15 mm [0.59 in.] below the -MAX- mark on the reservoir. This stops lubricant from entering the reservoir bleed screw. In the case of very strong vibrations or large tilting motions, this value must be increased, and can be reduced in the case of lesser vibrations. Changing the filling height by 10 mm [0.4 in.] equates to a change in volume of approx. 0.34 liters [0.09 gal.].

4.6 Lubricant volume when an empty pump is filled for the first time

The following volumes of lubricant are required in order to fill a new empty pump up to the -MAX- mark on the reservoir.

NOTE

The difference between the lubricant volume required for initial filling and the nominal volume of the reservoir is due to the filling of the space in the pump housing up to the -MIN- mark on the reservoir.

Table 13

Lubricant volume when an empty pump is filled for the first time

Reservoir
version

Nominal volume	2 [0.53]	4 [1.06]	8 [2.11]
Lubricant quantity	3.80 ± 0.25 [1 ± 0.07]	5.80 ± 0.25 [1.53 ± 0.07]	9.15 ± 0.25 [2.41 ± 0.07]

4.7 Tightening torques

Table 14

Tightening torques

Component	Torque
1 Pump element on pump	20 Nm ± 2.0 Nm [14.75 ft.lb. ± 1.4 ft.lb.]
2 Pressure limiting valve on pump element	6 Nm - 0.5 Nm [4.43 ft.lb. - 0.07 ft.lb.]
3 Fastening the pump	18 Nm ± 1.0 Nm [13.27 ft.lb. ± 0.74 ft.lb.]
4 Housing cover (bottom) when replacing	0.75 Nm ± 0.1 Nm [0.55 ft.lb. ± 0.07 ft.lb.]
5 Plug screw or adapter with cone-type grease nipple	10 Nm + 1.0 Nm [7.38 ft.lb. ± 0.7ft.lb.]
6 Screw cap	2 Nm ± 0.2 Nm [1.48 ft. lb. ± 0.15 ft.lb.]
7 Optional fill connection	20 Nm ± 2.0 Nm [14.75 ft.lb. ± 1.4 ft.lb.]
8 Rectangular connector, M3 screw	0.5 Nm [0.37 ft.lb.]

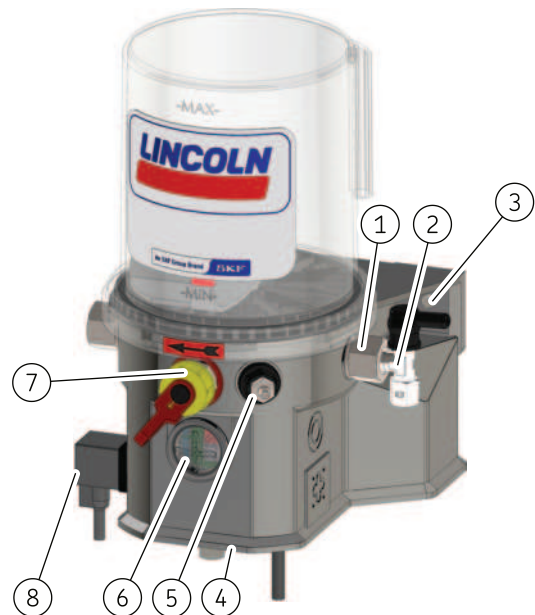

4.8 Type identification code

4.8.1 Basic parameters and reservoir version

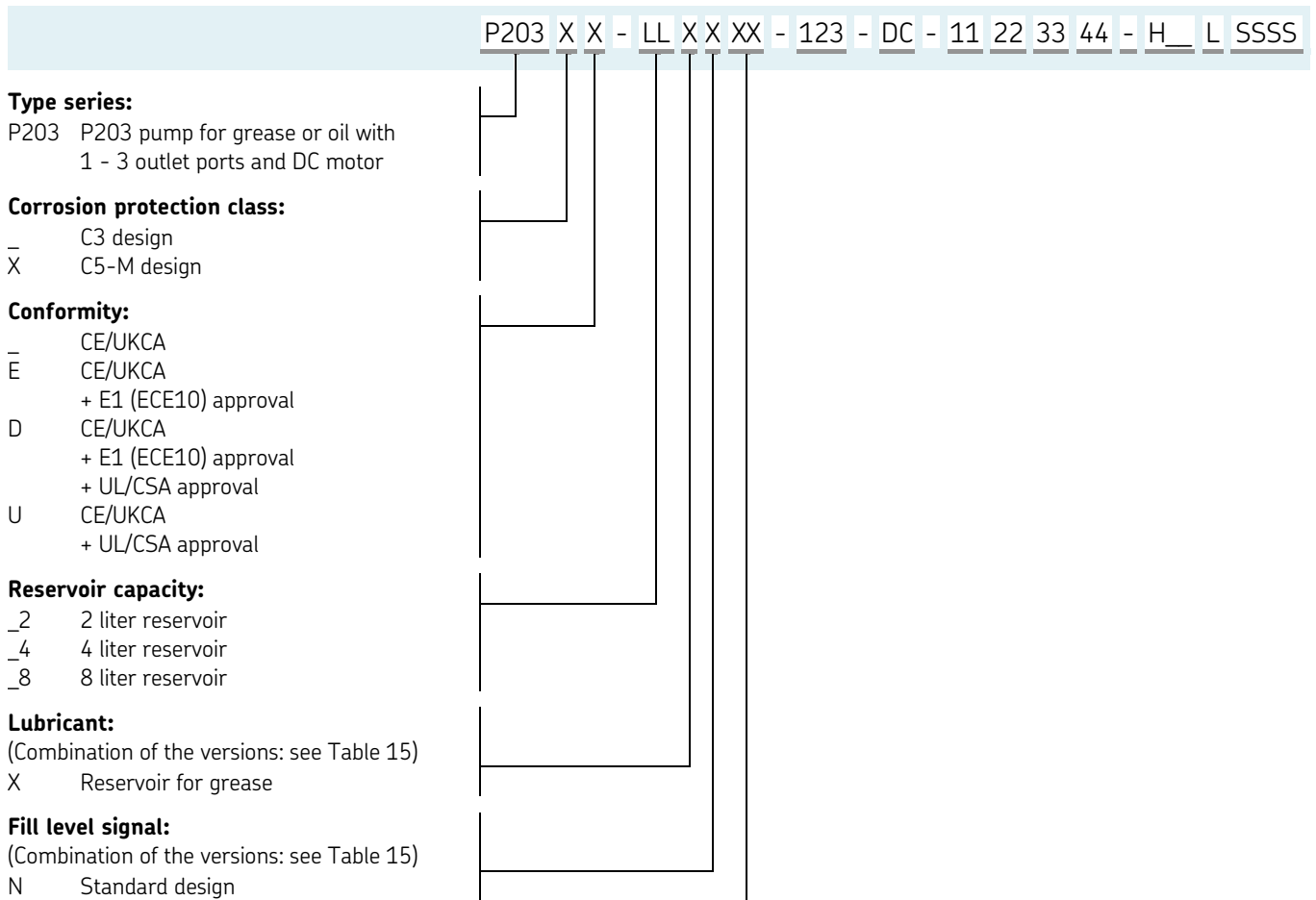

P203 X X - LL X X XX - 123 - DC - 11 22 33 44 - H L SSSS

Reservoir design:

(Combination of the versions: see Table 15)

BO Filling from above

FL Flat reservoir

¹⁾ Intermittent in the case of grease, float switch in the case of oil

²⁾ Sonar sensor in the case of grease, float switch in the case of oil

³⁾ Only for reservoirs with filling from above

Table 15

Reservoir versions

Code	Possible reservoir capacities					Description
	2 l	4 l	8 l			
X N --	✓	✓	✓			Reservoir for grease; without low-level signal (standard design)
X N FL	✓					Flat reservoir for grease; without low-level signal
X N BO	✓	✓	✓			Reservoir for grease; filling from above; without low-level signal

4.8.2 Pump elements

P203 X X - LL X X XX - 123 - DC - 11 22 33 44 - H_ L SSSS

Pump elements:

Position sequence: Right (Fig. 11/1), Center (Fig. 11/2) and Left (Fig. 11/3).
For coding, see Table 16

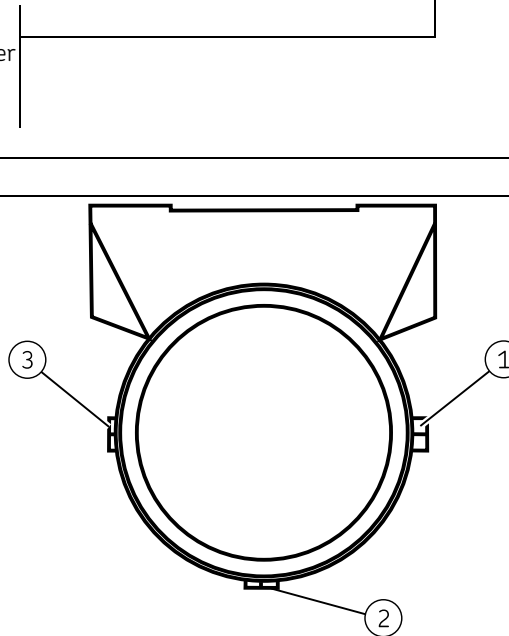

Fig. 11

Layout of pump elements

Table 16

Pump elements

Code	Description
0	Without/no pump element
5	Piston diameter = 5 mm
L	Piston diameter = 5 mm; delivery rate 0.03 ccm (only suitable for grease of NLGI grade 00)
6	Piston diameter = 6 mm
7	Piston diameter = 7 mm
R	Piston diameter = 7 mm, adjustable pump element
B	Piston diameter = 7 mm, delivery volume corresponds to pump element 5 (piston diameter = 5 mm)

4.8.3 Voltage supply and electrical connections

The P203 has four different connection options on the housing. These different connection positions are coded using four two-number groups in the type identification code.

- The first digit in a two-number group describes the plug/socket on the housing
- The second digit in a two-number group defines the plug/socket included in the scope of supply with/without cable

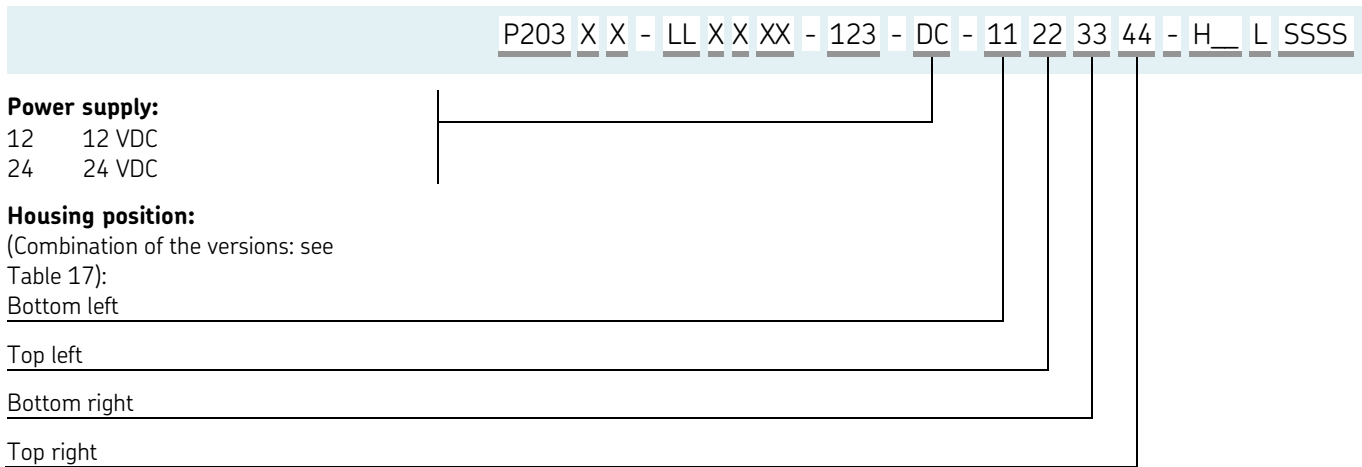

Table 17

Possible connection types:

		Housing position								Description
		Left				Right				
		Below	Top	Below	Top	Below	Top	Below	Top	
	I	II	I	II	I	II	I	II		
Coding and connection to the pump housing:										
0	-	0	-	0	-	0	-	0	-	0 No connection
A	-		-		-		-		-	A Rectangular connector - control circuit board/supply line, V10-V13 (pins 2 and 3 occupied)
C	-		-		-		-		-	C Rectangular connector - control circuit board/supply line, V10-V13 (pins 1 and 3 occupied)
E	-		-		-		-		-	E Rectangular connector - control circuit board/supply line, V20-V23
	-	5	-		-		-		-	5 Bayonet connector 4/3-pin
	-		-	F	-		-		-	F Rectangular connector - control circuit board/messages

Coding and accessories for the connection:

-	0	-	0	-	0	-	0	0	without connection socket, without cable
-	1	-		-		-		1	with connection socket, without cable (black)
-	A	-		-		-		A	with connection socket and 10 m cable
-	C	-		-		-		C	with connection socket and 10 m ADR cable
-		-	E	-		-		E	with connection socket and 10 m cable, 4/3-core, LLC
					2			2	with connection socket, without cable, gray
					B			B	with connection socket and 10 m cable
					D			D	with connection socket and 10 m ADR cable

4.8.4 Control, lubricant, and additional specifications

P203 X X - LL X X XX - 123 - DC - 11 22 33 44 - H_ L SSSS

Control circuit boards (12 V / 24 V):

H_ _ H control circuit board for trailer lubrication

Lubricant:

- A Standard grease (Fuchs Renocal FN 745)
- S Customized filling
- Z Without lubricant

Additional specifications:

- ADR For hazardous goods transportation
- A Version for USA, adapter with grease fitting with/without SV (pressure limiting valve), both NPT thread, (Europ. cable)
- A+SV Version for USA, adapter with grease fitting with SV, both NPT thread (US cable)
- +ZUB. With customized accessories

5. Delivery, returns, storage

5.1 Delivery

After receipt of the shipment, it must be inspected for any shipping damage and for completeness according to the shipping documents. Immediately inform the transport carrier of any shipping damage. The packaging material must be preserved until any discrepancies are resolved.

5.2 Return shipment

Before return shipment, all contaminated parts must be cleaned. If this is not possible or practical, e.g. if it would impede fault detection in the case of complaints, the medium used must always be specified. In the case of products contaminated with hazardous substances as defined by GHS or CLP regulations, the safety data sheet (SDS) must be sent with the product and the packaging must be labelled in accordance with GHS/CLP. There are no restrictions for land, air, or sea transport. The choice of packaging should be based on the specific product and the stresses to be expected during transport (e.g., necessary anti-corrosion measures in the case of shipment by sea). In the case of wooden packaging, the applicable import regulations and the IPPC standards must be observed. Required certificates must be included in the shipping documents. The following information, as a minimum, must be marked on the packaging of return shipments.



Marking of return shipments

5.3 Storage

The following conditions apply to storage:

- Dry, low-dust, vibration-free, in closed rooms
- No corrosive, aggressive substances at the storage location (e.g., UV rays, ozone)
- Protected against animals (insects, rodents)
- If possible, keep in the original product packaging
- Protected from nearby sources of heat or cold
- In the case of large temperature fluctuations or high humidity, take appropriate measures (e.g., heating) to prevent the condensation of water
- Before usage, check products for damage that may have occurred during storage. This applies in particular to parts made of plastic (due to embrittlement).

5.4 Storage temperature range

For parts not filled with lubricant, the permitted storage temperature is the same as the permitted ambient temperature range (see "Technical data").

5.5 Storage conditions for products filled with lubricant

For products filled with lubricant, the permitted storage temperature range is:

minimum	+ 5 °C	[+41 °F]
maximum	+ 35 °C	[+95 °F]

If the storage temperature range is not maintained, the following steps for replacing the lubricant may not lead to the desired result under certain circumstances.

5.5.1 Storage period up to 6 months

Filled products can be used without implementing additional measures.

5.5.2 Storage period between 6 and 18 months

Pump:

- Connect the pump to a power source
- Switch on the pump and run it until lubricant comes out of every outlet without air bubbles
- Disconnect the pump from the power source
- Remove and dispose of the lubricant that came out

Lines:

- Remove pre-installed lines
- Ensure that both ends of the line are open
- Fill the lines completely with fresh lubricant

Metering devices:

NOTE

Due to the large number of different metering devices, no universally valid statement can be made regarding the removal of the old lubricant and correct bleeding after filling with new lubricant. The instructions can be found in the technical documentation of the specific metering device used.

5.5.3 Storage period more than 18 months

To prevent faults, the manufacturer should be consulted before start-up. The basic procedure for removal of the old lubrication filling corresponds to that for storage periods between 6 and 18 months.

6. Assembly

6.1 General safety instructions

Observe the safety instructions and the technical data in this manual. Additionally, during assembly pay attention to the following:

- Only qualified and authorized technical personnel may install the products described in this manual.
- Adhere to safety distances and legal prescriptions on assembly and prevention of accidents.
- Possibly existing visual monitoring devices, e.g. pressure gauges, MIN/MAX markings, oil inspection glasses must be clearly visible.
- Protect the product against humidity, dust and vibrations.
- Install the product in an easily accessible position. This facilitates other installations, control and maintenance work.

6.2 Transporting the pumps

⚠ CAUTION

Injury or pump damage due to improper securing or handling when transporting to the installation location

- During transportation, secure the pump against unintended changes of position, e.g., tilting or falling
- Transport only on marked routes, using suitable transport and lifting gear, including securing straps if necessary

NOTE

The pumps listed in these instructions may be transported only in upright position when filled, because otherwise lubricant could escape from the reservoir and could enter the reservoir ventilation and clog it up.

6.3 Mechanical connection

6.3.1 Minimum mounting dimensions

In order to have sufficient space for maintenance work or for the attachment of additional components for the construction of a centralized lubrication system on the pump, sufficient clearance should be provided for in every direction in addition to the specified dimensions.

Fig. 13

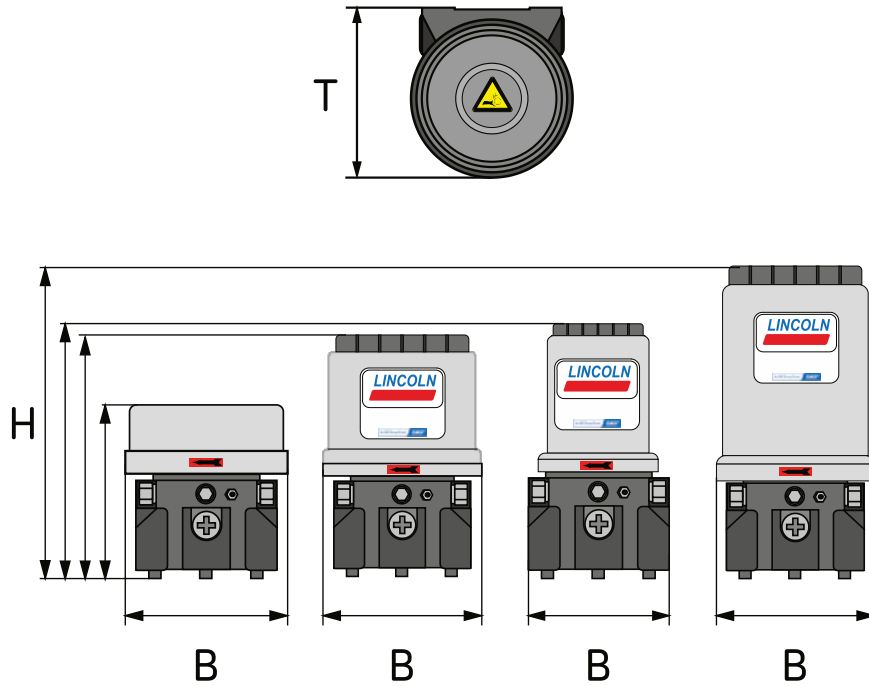

Minimum mounting dimensions

Table 18

P203 minimum mounting dimensions

Reservoir version	Reservoir size			Reservoir size			Reservoir size		
	Approx. height (H) mm [in.]			Approx. width (B) mm [in.]			Approx. depth (T) mm [in.]		
liter gal.	2	4	8	2	4	8	2	4	8
XN	325 [12.80]	355 [13.98]	458 [18.03]	213 [8.39]	230 [9.06]	250 [9.84]	224 [8.81]	250 [9.84]	250 [9.84]
XNFL	244 [9.61]	-----	-----	232 [9.13]	-----	-----	250 [9.84]	-----	-----
XNBO	360 [14.17]	350 [13.78]	457 [18]	211 [8.30]	232 [9.13]	232 [9.13]	224 [8.82]	250 [9.84]	250 [9.84]

6.3.2 Assembly holes

NOTICE

Possible damage to the main machine and the pump

The assembly holes should be created only on non-load-bearing parts of the main machine. Do not fasten on two parts which move in opposite directions to one another (e.g., machine base and machine assembly).

The mounting takes place with:

- 2 or 3 screws M8 (8.8)
- 2 or 3 hexagon nuts M8 (8.8)
- 2 or 3 washers (8)

Diameter of the holes in the pump housing:

∅ 9 mm [0.35 in.]

Pumps with 2 l [0.53 gal] reservoir:

The pumps are fastened at the two lower fastening points (Fig. 14/1) or (Fig. 14/2) of the pump housing:

A1 = 162 mm [6.38 in.]

B1 = 180 mm [7.09 in.]

A2 = 124 mm [4.88 in.]

B2 = 112 mm [4.41 in.]

Pumps with 2 l flat reservoir [0.53 gal] or 4 l [1.06 gal] or 8 l [2.11 gal] reservoir:

The pumps are fastened at the three lower fastening points (Fig. 14/1) or (Fig. 14/2) and (Fig. 14/3) of the pump housing:

C1 = 83 mm [3.27 in.]

C2 = 95 mm [3.74 in.]

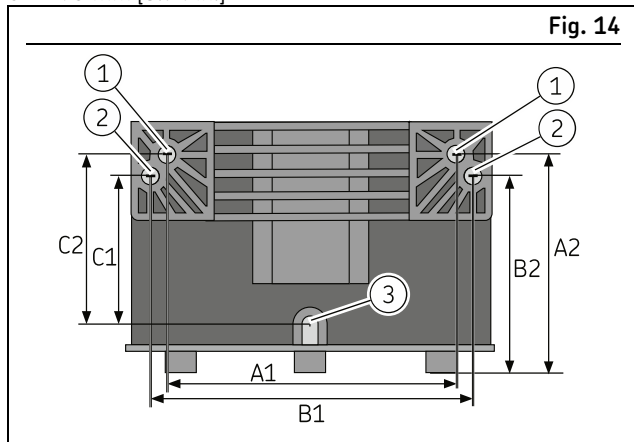

Fastening points at the bottom of the pump housing

6.4 Electrical connections

Fig. 15





Electrical connections of the P203

1 Power supply (rectangular connector)

2 Power supply (bayonet connector)

Table 19

Possible versions of the electrical connections

1		Rectangular connector 3 + PE acc. to DIN EN 175301-803
2		Bayonet connector, 4-pin, acc. to ISO 15170-1

NOTE

The design and arrangement of the electrical connections depend on the pump version ordered.

⚠ WARNING



Electric shock

Work on electrical components may be performed only by qualified electricians.

At a minimum, the following safety measures must be taken before any work on electrical components is done:



- Isolate, lock and tag out
- Check to ensure the absence of voltage
- Ground and short-circuit the product
- Cover any live parts in the surrounding area

Observe the following instructions for a safe connection:

- The electrical connection must be implemented in accordance with the specifications of the standards of the DIN VDE 0100 series or of the standards of the IEC 60364 series, respectively

Connect the electrical lines in such a way that no mechanical forces are transferred to the product

- The pump must be secured with a suitable external fuse (see terminal diagram)

The electrical connection is established in accordance with the type of connection of the specific pump.

1. Assemble the required cables in accordance with the respective connection diagram or use preassembled cables for the connection.
2. Connect plugs with their respective bushes and secure them against becoming loose using the type of securing method specified for the quick disconnect couplings. Only this way is a safe connection and compliance with the enclosure rating secured.

NOTE

Connect the cables in such a way that no tensile forces can be transferred to the product.

6.5 Setting the delivery rate on pump element R

Fig. 16

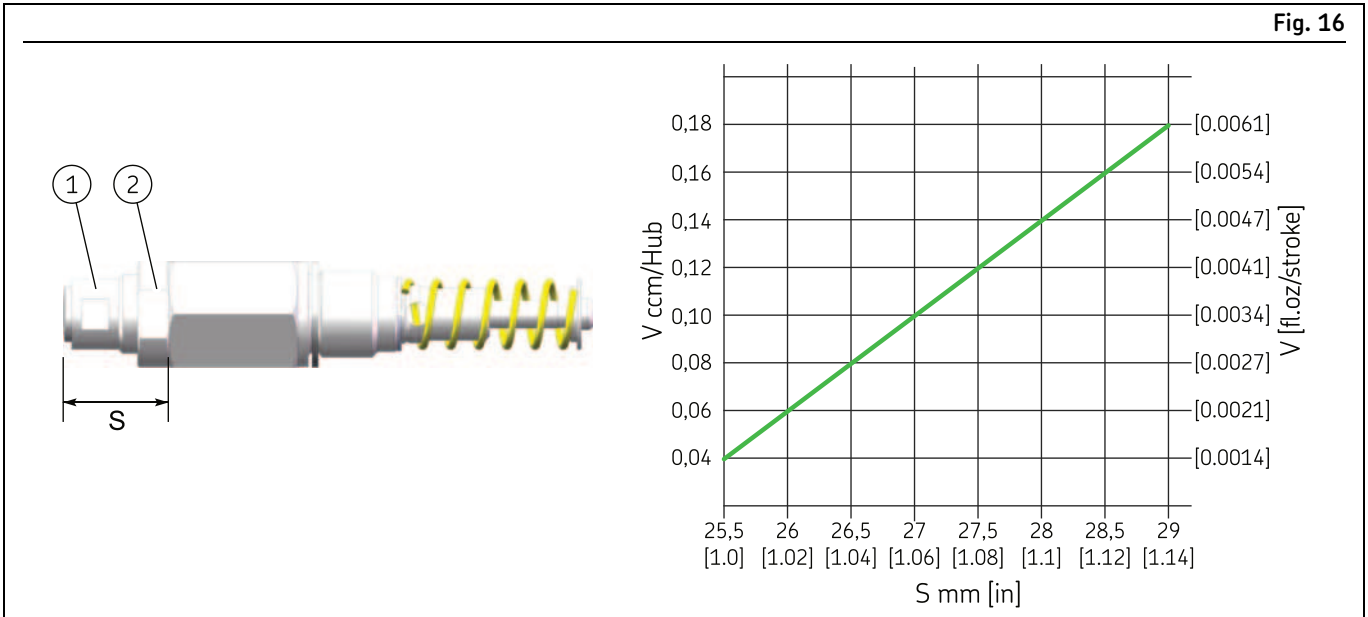

Setting the delivery rate on pump element R

- 1 Spindle
- 2 Locknut

S Spindle setting dimension
V Delivery volume per stroke

NOTE



Be sure to observe the formula for temperature-dependent calculation of the delivery rate using the example of a high-temperature grease, in the section Delivery rate charts for typical NLGI 2 lubricants, 21.

NOTE

The delivery rate of pump element R can be adjusted only when the pump is at a standstill.
When delivered, the rate is set to full delivery, meaning the setting dimension is
S = 29 mm [1.14 in.].

Proceed as follows for setting:

1. Release the locknut (Fig. 16/2)
2. Set the delivery rate by turning the spindle (Fig. 16/1) to the dimension specified on the chart in Figure 16.

 = lower delivery rate
 = higher delivery rate

3. Once the delivery rate is set, tighten the locknut (Fig. 16/1) again.
- Tightening torque: 20 Nm \pm 2.0 Nm [14.75 ft.lb. \pm 1.4 ft.lb.]

6.6 Installing the pressure limiting valve

Each pump element must be secured with a pressure limiting valve that is suitable for the projected maximum approved operating pressure of the centralized lubrication system.

NOTE

For the 2L XNFL reservoir versions and for all 4L and 8L reservoirs, the adapter 226-14105-5 (see "Spare parts" section) must be screwed in between the pump element and the pressure limiting valve and secured with a medium-strength threadlocker.

Proceed as follows for installation:

1. Remove the plug screw (Fig. 17/2) from the pump element (Fig. 17/1)
2. Screw the pressure limiting valve (Fig. 18/2) into the pump element (Fig. 18/1)
3. Repeat the procedure for each pump element

Fig. 17



Remove the plug screw

Fig. 18



Installing the pressure limiting valve

Tightening torques

- Pressure limiting valve in pump element:
6 Nm - 0.5 Nm [4.43 ft.lb. ± 0.07 ft.lb.]
- Adapter in the pump element:
8 Nm - 0.5 Nm [5.9 ft.lb. ± 0.07 ft.lb.]

6.7 Connection of the lubrication line

CAUTION



Risk of slipping

Exercise caution when handling lubricants. Immediately remove and bind any leaked lubricants.

NOTICE

Damage to the higher-level machine caused by faulty planning of the centralized lubrication system

All parts for the construction of the centralized lubrication system must be designed for the maximum operating pressure that occurs, the permissible ambient temperature range, the required delivery volume, and the lubricant to be supplied.

Observe the following assembly information for safe and trouble-free operation:

- Generally valid regulations and company regulations regarding the laying of pressurized pipe and hose lines must be observed.
- Use only clean, pre-filled components and lubrication piping.
- Secure every lubricant line on the pump against excessive pressure through the use of a suitable pressure relief valve (only in the case of pumps without an internal pressure relief valve).
- The main lubricant line should be arranged ascending and be able to be bled at the highest point. Lubrication lines should always be arranged so that air inclusions cannot form anywhere.
- Install lubricant metering devices at the end of the main lubricant line such that the outlets of the lubricant metering devices point upwards wherever possible.
- If the system configuration requires that the lubricant metering devices be arranged below the main lubricant line, they should not be placed at the end of the main lubricant line.
- The flow of lubricant should not be impeded by the presence of sharp bends, angle valves, flap valves, seals protruding inward, or changes in cross-section (large to small). Unavoidable changes in the cross-section in lubrication lines must have smooth transitions.
- Connect the lubricant lines in such a way that no mechanical forces are transferred to the product (stress-free connection).
- Lubrication piping is to be positioned in such a way that they cannot become kinked, pinched or frayed.

6.8 Filling with lubricant

6.8.1 Filling via the reservoir cover

WARNING



Crushing hazard

Crushing hazard on the rotating stirring paddle. Filling through the opening of the reservoir lid is permitted only when the pump has been disconnected electrically beforehand by detaching the connection (Fig. 19/ 2) from the power supply.



Fig. 19

Filling via the reservoir cover

1. Disconnect the power supply to the pump by detaching the connector (Fig. 19/2).
2. Turn the reservoir lid (Fig. 19/1) counterclockwise and detach it from the reservoir. Set the reservoir cover down at a clean location. The inner side of the reservoir cover must not become contaminated. Remove any contaminations which may be present.
3. Fill the reservoir from the top up to the "MAX" marking (Fig. 19/3). Take care to ensure while doing so that the lubricant is filled in without air inclusions if at all possible.
4. Reinstall the reservoir cover (Fig. 19/1) in clockwise direction.
5. Restore the power supply to the pump by attaching the connector (Fig. 19/2) and screwing it firmly in place.

6.8.2 Filling via filler nipple



Filling via the filler nipple

1. Connect the fill connection of the filling pump to the filler nipple (Fig. 20/1).
2. Switch on the filling pump and fill the reservoir up to just below the - MAX - marking (Fig. 20/2).
3. Switch off the filling pump and remove it from the filler nipple (Fig. 20/1) of the pump.

6.8.3 Filling via the optional fill connection

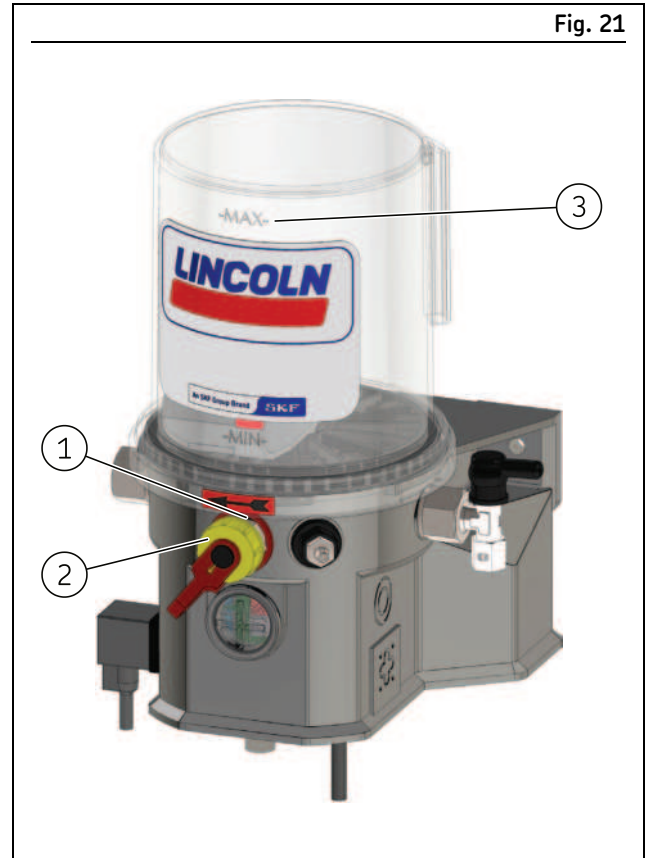

Filling via the optional fill connection

1. Switch on the pump and allow it to run during filling.
2. Unscrew the protective cap (Fig. 21/2) from the fill connection (Fig. 21/1).
3. Connect the fill connection of the filling pump to the fill connection (Fig. 21/1).
4. Switch on the filling pump and fill the reservoir up to just below the - MAX - marking (Fig. 21/2).
5. Switch off the filling pump and remove it from the fill connection (Fig. 21/1) of the pump.
6. Screw the protective cap (Fig. 21/2) onto the fill connection (Fig. 21/1).
7. Switch off the pump.

6.9 Setting the lubrication time

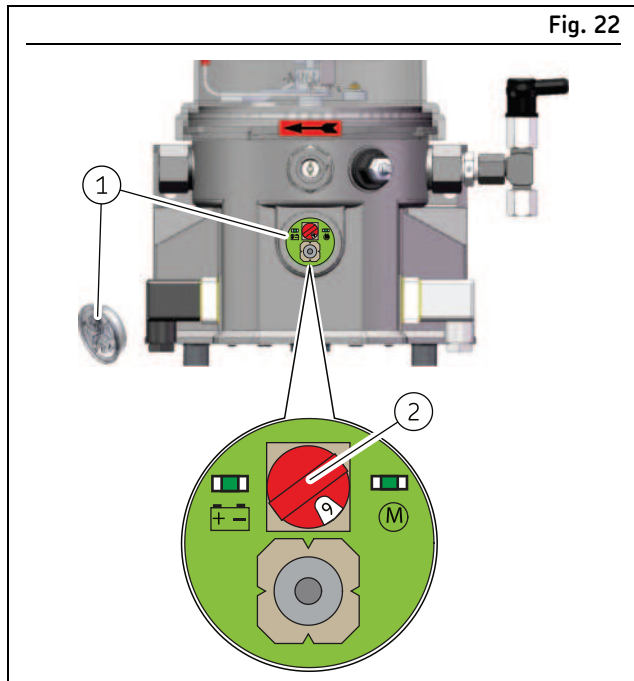

P203 with control circuit board H

The lubrication time is set using the rotary switch on the control circuit board. See Table 20 for the time that corresponds to the switch position.

Proceed as follows for setting:

1. Remove the screw cap (Fig. 22/1) together with the packing ring
2. Set the lubrication time by turning the red rotary switch (Fig. 22/3)
3. Reinstall the screw cap together with the packing ring
– Tightening torque 2 Nm \pm 0.2 Nm [1.48 ft.lb. \pm 0.15 ft.lb.]

NOTE

The newly set lubrication time does not take effect until you switch the power supply to the pump off and back on again.

6.9.1 Possible settings for lubrication time

Table 20

Settings for lubrication time

Position of the rotary switch (red)	1	2	3	4	5	6	7	8	9	A	B	C	D	E	F
Lubrication time in minutes*	2	4	6	8	10	12	14	16	18	20	22	24	26	28	30
Factory setting			X												

* The time values for the lubrication time are set at the factory using the rotary switches on the control circuit board.

NOTICE

Impairment of pump function

Never turn the rotary switches to the "0" position. This position is intended solely for the purposes of the manufacturer.

7. First start-up

In order to warrant safety and function, a person assigned by the operator must carry out the following inspections. Immediately eliminate detected deficiencies. Deficiencies may be remedied by an authorized and qualified specialist only.

7.1 Inspections before first start-up

Table 21		
Checklist: Inspections before first start-up		
Inspections to be performed	YES	NO
Electrical connection established correctly.	<input type="checkbox"/>	<input type="checkbox"/>
Mechanical connection established correctly.	<input type="checkbox"/>	<input type="checkbox"/>
The parameters set on the control are appropriate for the pump's intended application.	<input type="checkbox"/>	<input type="checkbox"/>
The performance characteristics for the aforementioned connections match the specifications in the "Technical data".	<input type="checkbox"/>	<input type="checkbox"/>
All components, e.g. lubrication lines, are pre-filled with the correct lubricating grease and correctly installed.	<input type="checkbox"/>	<input type="checkbox"/>
No apparent damage, contamination, or corrosion.	<input type="checkbox"/>	<input type="checkbox"/>
Product is protected by a suitable pressure relief valve.	<input type="checkbox"/>	<input type="checkbox"/>
Any dismantled protective and monitoring equipment is fully reinstalled and functional.	<input type="checkbox"/>	<input type="checkbox"/>
All warning labels on the product are present and in proper condition.	<input type="checkbox"/>	<input type="checkbox"/>
The lubricant used matches the permissible specifications of the pump and the intended use.	<input type="checkbox"/>	<input type="checkbox"/>

7.2 Inspections during first start-up

Table 22		
Checklist: Inspections during first start-up		
Inspections to be performed	YES	NO
No unusual noises, vibrations, moisture accumulation, or odors present.	<input type="checkbox"/>	<input type="checkbox"/>
No undesired discharge of lubricant at connections (leakage).	<input type="checkbox"/>	<input type="checkbox"/>
Lubricant is fed without bubbles.	<input type="checkbox"/>	<input type="checkbox"/>
The bearings and friction points requiring lubrication receive the planned lubricant volume.	<input type="checkbox"/>	<input type="checkbox"/>

8. Operation

SKF products operate automatically to the greatest possible extent.

Basically, activities during standard operation are limited to:

- Regular function checks
- Checking the fill level on pumps without low-level signal
- Timely refilling of lubricant
- Cleaning the exterior if dirty

8.1 Top up lubricant

See section Filling with lubricant, Page 37.

9. Maintenance and repair

Careful and regular maintenance is required in order to detect and remedy possible faults in time. The operator must always determine the specific intervals according to the operating conditions, review them regularly, and adjust them where necessary. If necessary, copy the table for regular maintenance activities.

Table 23

Checklist: Maintenance activities

Activity to be performed	YES	NO
Mechanical and electrical system connections established correctly	<input type="checkbox"/>	<input type="checkbox"/>
The performance characteristics for the aforementioned connections match the specifications in the "Technical data"	<input type="checkbox"/>	<input type="checkbox"/>
All components such as lubrication lines and metering devices are correctly installed	<input type="checkbox"/>	<input type="checkbox"/>
Product is protected by a suitable pressure relief valve	<input type="checkbox"/>	<input type="checkbox"/>
No apparent damage, contamination, or corrosion	<input type="checkbox"/>	<input type="checkbox"/>
Any dismantled protective and monitoring equipment is fully reinstalled and functional	<input type="checkbox"/>	<input type="checkbox"/>
All warning labels on the product are present and in proper condition	<input type="checkbox"/>	<input type="checkbox"/>
No unusual noises, vibrations, moisture accumulation, or odors present	<input type="checkbox"/>	<input type="checkbox"/>
No undesired discharge of lubricant (leakages) at connections	<input type="checkbox"/>	<input type="checkbox"/>
Lubricant is fed without bubbles	<input type="checkbox"/>	<input type="checkbox"/>
The bearings and friction points requiring lubrication receive the planned lubricant volume	<input type="checkbox"/>	<input type="checkbox"/>

10. Cleaning

⚠ WARNING

⚡ Risk of fatal electric shock



 Cleaning work may only be performed on products that have been de-energized first. When cleaning electrical components, be mindful of the IP enclosure rating.



⚠ WARNING

! Serious injury from contact with or inhalation of hazardous substances

 Wear personal protective equipment. Observe the safety data sheet (SDS) of the hazardous substance. Avoid contaminating other objects or the environment during cleaning.

10.1 Basics

Cleaning should be carried out in accordance with the operator's own company rules, and cleaning agents and devices and the personal protective equipment to be used should likewise be selected in accordance with those rules. Only cleaning agents compatible with the materials may be used for cleaning. Completely remove any cleaning agent residue left on the product and rinse with clear water. Unauthorized persons must be kept away. Use signage to indicate wet areas.

10.2 Interior cleaning

The interior normally does not need to be cleaned. The interior of the product must be cleaned if incorrect or contaminated lubricant accidentally enters the product. Please contact our Service department.

10.3 Exterior cleaning

Do not allow any cleaning fluid to enter the interior of the product during cleaning.

11. Faults, causes, and remedies

Table 24

Fault table

Fault	Possible cause	Remedy
Pump does not run	<ul style="list-style-type: none"> • Power supply to pump interrupted. <ul style="list-style-type: none"> – Main machine is switched off – Pump power cable detached or defective – External fuse defective – The pump is in pause time – The motor of the pump is faulty – Internal cable break • Control circuit board or power supply board is defective 	<ul style="list-style-type: none"> • Check whether one of the specified faults exists, and remedy it according to responsibility • Faults outside one's own scope of responsibility must be reported to the supervisor for initiation of further measures • Please contact our Customer Service if you cannot determine or resolve the error
Pump runs, but supplies either no lubricant at all or not enough	<ul style="list-style-type: none"> • Jam, malfunction within the centralized lubrication system • Check valve defective • Pressure limiting valve defective • Suction bore in a pump element is clogged • Worn pump element • Air inclusion in the lubricant / under the follower plate • Consistency of the lubricant is too high (at low temperatures) • Consistency of the lubricant is too low (at high temperatures) • Metering device within the centralized lubrication system is configured incorrectly 	<ul style="list-style-type: none"> • Check whether one of the specified faults exists, and remedy it according to responsibility • Faults outside one's own scope of responsibility must be reported to the supervisor for initiation of further measures • Please contact our Customer Service if you cannot determine or resolve the error

11.1 Indication of operational and fault states by the LEDs on the control circuit board

Certain operational and fault states are indicated by the LEDs on the control circuit boards.

Fig. 23

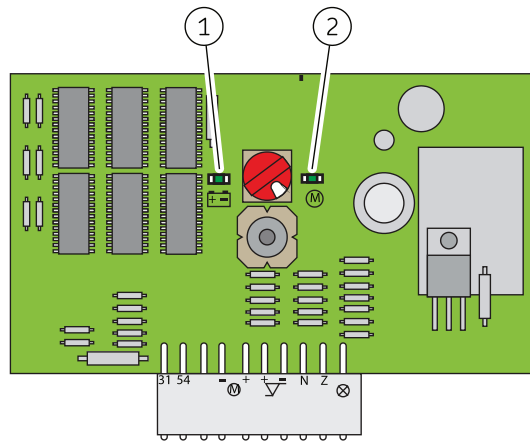

LEDs on the control circuit board

Table 25

Meaning of the LED displays

Display	Possible causes	Remedy
Both LEDs (1+2) off	<ul style="list-style-type: none"> No (or insufficient) operating voltage at terminal 54 Control circuit board is faulty – Internal cable break 	Switch on the operating voltage; replace the control circuit board if defective
Left LED (1) is permanently lit	<ul style="list-style-type: none"> Operating voltage is applied to terminal 54 	No fault, normal operating state (pause time)
Both LEDs (1+2) are permanently lit	<ul style="list-style-type: none"> Motor is running 	No fault, normal operating state (lubrication time)

12. Repairs

⚠ WARNING

Risk of injury

At a minimum, the following safety measures must be taken before any repairs:

- Unauthorized persons must be kept away
- Mark and secure the work area
- Depressurize the product
- Isolate the product, and lock and tag it out
- Check to ensure live voltage is no longer present
- Ground and short-circuit the product
- Cover any adjacent live parts

NOTE
The characteristics of the new pump element must match the characteristics of the pump element to be replaced.

12.1 Replacing pump element and pressure limiting valve

- Replace the pump element as instructed below:
1. Remove the defective pump element (Fig. 24/1) from the pump housing together with the pressure limiting valve (Fig. 24/3), by unscrewing on the hexagon of the pump element.
 2. Screw the new pump element (Fig. 24/1) together with a new packing ring into the pump housing. Remove plug if necessary (Fig. 24/2).
 - The torque for tightening the pump element is 20 Nm ± 2.0 Nm [14.75 ft.lb. ± 1.4 ft.lb.]
 3. Afterwards, screw a new pressure limiting valve (Fig. 24/3) into the pump element.
 - The torque for tightening the pressure limiting valve is 6 Nm -0.5 Nm [4.43 ft.lb. -0.07 ft.lb.]



Replacing pump element and pressure limiting valve

12.2 Replacing the control circuit board

Fig. 25

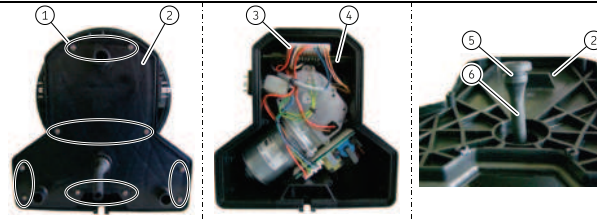

Replacing the control circuit board

- 1 Screws (10x) for lower housing cover
- 2 Housing cover
- 3 Plug on the control circuit board
- 4 Control circuit board
- 5 Groove on the dewatering hose
- 6 Dewatering hose

NOTE

The work should be done at room temperature if possible. Very low temperatures could make replacement difficult. To make it easier to replace the control circuit board, tilt the pump into a horizontal position.

The scope and results of the inspection after replacement of the control circuit board must be recorded in writing and given to the party responsible for operation of the machine, for archiving.

Proceed as follows to replace the control circuit board:

1. Check that the new control circuit board matches the documentation and the intended use.
2. Take protective measures against electrostatic discharge.
3. Remove the screws (Fig. 25/1) from the housing cover (Fig. 25/2).
4. Removing the housing cover
5. Pull the plugs (Fig. 25/3) out of the control circuit board and pull the control circuit board (Fig. 25/4) out of the two side guide rails.
6. Make a note of any altered jumper positions and rotary switch settings and transfer them to the new control circuit board.
7. Place the control circuit board in the side guide rails and carefully push it down.
8. Re-insert the plugs.
9. Guide the dewatering hose (Fig. 25/6) through the housing cover (Fig. 25/2) from the rear until its groove (Fig. 25/5) engages securely in the housing cover
10. Place the housing cover on the pump housing and install it again with the screws
 - Tightening torque 0.6 Nm \pm 0.1 Nm [0.44 ft.lb. \pm 0.01 ft.lb.]
11. Install the pump at the place of use again.
 - Installation and start-up at the place of use should be done as described in the Assembly chapter.

Checks after replacing the control circuit board

NOTE

An electrical inspection in accordance with EN 60204-1 must be performed after the replacement of the control circuit board.

Archiving

13. Shutdown, disposal

13.1 Temporary shutdown

Temporary shutdowns should be done by a course of action to be defined by the operator.

13.2 Permanent shutdown, disassembly

Permanent shutdown and disassembly of the product must be planned properly by the operator and conducted in compliance with all applicable laws and regulations.

13.3 Disposal

The waste producer/operator must dispose of the various types of waste in accordance with the applicable laws and regulations of the country in question.

14. Spare parts

Spare parts may be used exclusively for replacement of identical defective parts. Modifications with spare parts on existing products are not allowed.

14.1 Housing cover, complete

Designation	Pcs.	Item number	Figure
Housing cover, complete	1	544-32217-1	
Housing cover, complete, for UL-certified pumps	1	544-60207-1	

Delivery including dewatering hose and the appropriate number of screws for installation

14.2 Pump elements

Designation	Pcs.	Item number C3 design	Item number C5-M design	Figure
Pump element L incl. packing ring	1	600-78018-1	not available	
Pump element 5 incl. packing ring	1	600-26875-2	600-29303-1	
Pump element 6 incl. packing ring	1	600-26876-2	600-29304-1	
Pump element 7 incl. packing ring	1	600-26877-2	600-29305-1	
Pump element R incl. packing ring	1	655-28716-1	not available	
Pump element B incl. packing ring	1	600-29185-1	not available	

14.3 Pressure limiting valves and adapters

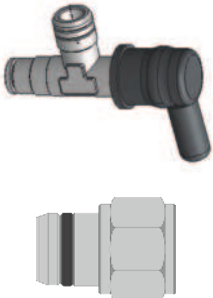
Designation	Pcs.	Item number	Figure
SVTS-350-R1/4-D6 C3	1	624-28894-1	
SVTS-350-R1/4-D6 C5 M	1	624-29343-1	
SVET-350-G1/4 A-D8 3	1	624-29054-1	
SVTS-270-R1/4-1/8 NPTFI-NIPOOR-A C 3	1	270864	
Adapter S2520 1/4-1/4 PTFE packing ring	1	226-14105-5	

Other pressure limiting valves in C3 and C5-M on request.

14.4 Adapter D6 AX 1/8NPT I C

Designation	Pcs.	Item number	Figure
Adapter for pressure limiting valve 270864 C3	1	304-19614-1	

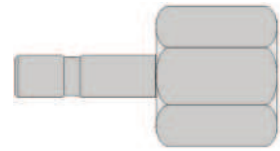

14.5 Adapter with lubricant nipple

Designation	Pcs.	Item number	Figure
Adapter with lubricant nipple ST 1/4 NPTF incl. seal	1	519-33840-1	
Adapter with lubricant nipple A2 AR 1/4 incl. seal	1	519-33959-1	
Adapter with lubricant nipple ST AR 1/4 incl. seal	1	519-33955-1	

14.6 Plug screw M22x1.5

Designation	Pcs.	Item number	Figure
Plug screw M22x 1.5 incl. seal	1	519-60445-1	

Used to close an unused outlet, e.g., when a pump element is removed.

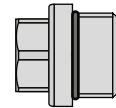

14.7 Motor 12 / 24 VDC

Designation	Pcs.	Item number	Figure
Motor 12 VDC	1	544-36913-6	
Motor 24 VDC	1	544-36913-7	

Delivery includes 1 x motor connection for control circuit board; 2 x O-ring 142 x 4; 3 x O-ring 6 x 2; 1 x radial shaft seal; 3 x self-tapping screw M6 x 25; 3 x washer; 1 x woodruff key; 1 x housing cover with dewatering hose and the matching number of screws for installation

14.8 Replacement kit for control circuit board

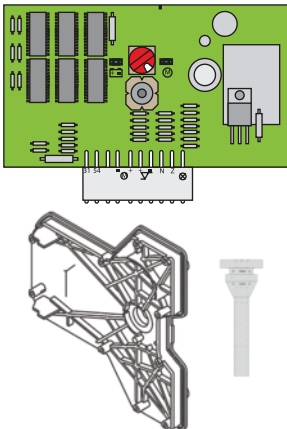
Designation	Pcs.	Item number	Figure
Replacement kit for control circuit board H		544-60242-1	
Delivery including housing cover, dewatering hose and the appropriate number of screws for installation			

14.9 Transparent reservoir

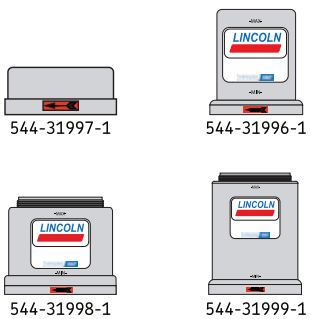
Designation	Pcs.	Item number	Figure
2l XNFL ^{B,C}	1	544-31997-1	
2l XN ^{A,B,C}	1	544-31996-1	
4l XNBO ^{A,B,C}	1	544-31998-1	
8l XNBO ^{A,B,C}	1	544-31999-1	
Delivery includes: A = Lincoln/SKF logo, B = Rotation arrow stickers, C = O-ring			
<div style="border: 1px solid black; padding: 5px;"> <p>NOTE Other transparent reservoirs on request.</p> </div>			

14.10 Fixed paddle

Designation	Pcs.	Item number	Figure
Fixed paddle 4 XNBO	1	444-70490-1	
Fixed paddle 8 XNBO	1	444-70491-1	

14.11 Reservoir cover

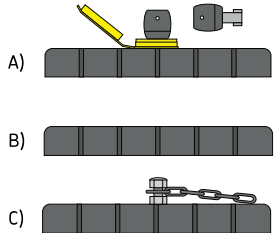
Designation	Pcs.	Item number	Figure
C) Reservoir cover 2 l [0.53 gal.] XNBO	1	544-85156-1	

14.12 Screw cap

Designation	Pcs.	Item number	Figure
Screw cap on the pump housing	1	544-32851-1	

14.13 Connection sockets and cables

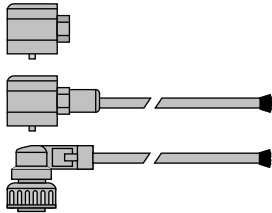
Feature*	Designation	Pcs.	Item number	Figure
1	Connection socket ^{H)} with seal and screw	1	544-32850-1	
A	Connection cable 10 m (33 ft.) with connection socket ^{H)}	1	664-36078-7	
C	Connection cable 10 m (33 ft.) ADR with connection socket ^{H)}	1	664-36862-1	
E	Connection cable 10 m (33 ft.) with bayonet socket (7/5-pin)	1	664-34167-2	
Feature*	Enclosure rating (IEC 60529)			
1	IP 65			
A	IP 67			
C	IP 65			
E	IP 6K9K			

H) = black

* = feature in the type identification code (category K, connection hardware)

15. Appendix

15.1 Connection diagrams

NOTE

- You can find the right terminal diagrams for each specific pump version by referring to the type identification code features applied on the terminal diagrams.

Type identification code, Page 25

Table 26

Cable colors in accordance with IEC 60757

Abbreviation	Color	Abbreviation	Color	Abbreviation	Color	Abbreviation	Color
BK	Black	GN	Green	WH	White	PK	Pink
BN	Brown	YE	Yellow	OG	Orange	TQ	Turquoise
BU	Blue	RD	Red	VT	Violet	GY	Gray
GNYE	Green/Yellow	RDWH	Red/White	GD	Gold	SR	Silver

Not all cable colors need to be used in the terminal diagrams.

15.1.1 Overview of cables and possible connections

Table 27

Cables and possible connections

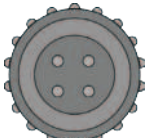
Plug	External		Pump			Polarity	Item number	Cable		
	Color	Pin	Color	Internal Function	Function			Length	Cross-section	Enclosure rating
 Rectangular connector	RD	1	RD	+12/24VDC	+12/24V	664-36078-7	10 m	4xAWG 18	IP 67	
	BN	2	BN	GND	GND	664-36862-2	10 m	4x0.82 mm ²		
	BK	3	BK	Counter/Ignition	positive					
	GN/YE	PE	GY/GY	PE	PE					
 Bayonet 4/3-pin	RD	1	RD	+12/24VDC	+12/24V	664-34167-6	10 m	3x1.5 mm ²	IP 6K9K	
	BN	2	BN	GND	GND					
	BK	3	BK	Counter/Ignition	positive					
		4								

15.1.2 Terminal diagram P203 VDC, with control circuit board H and rectangular connector

Fig. 26

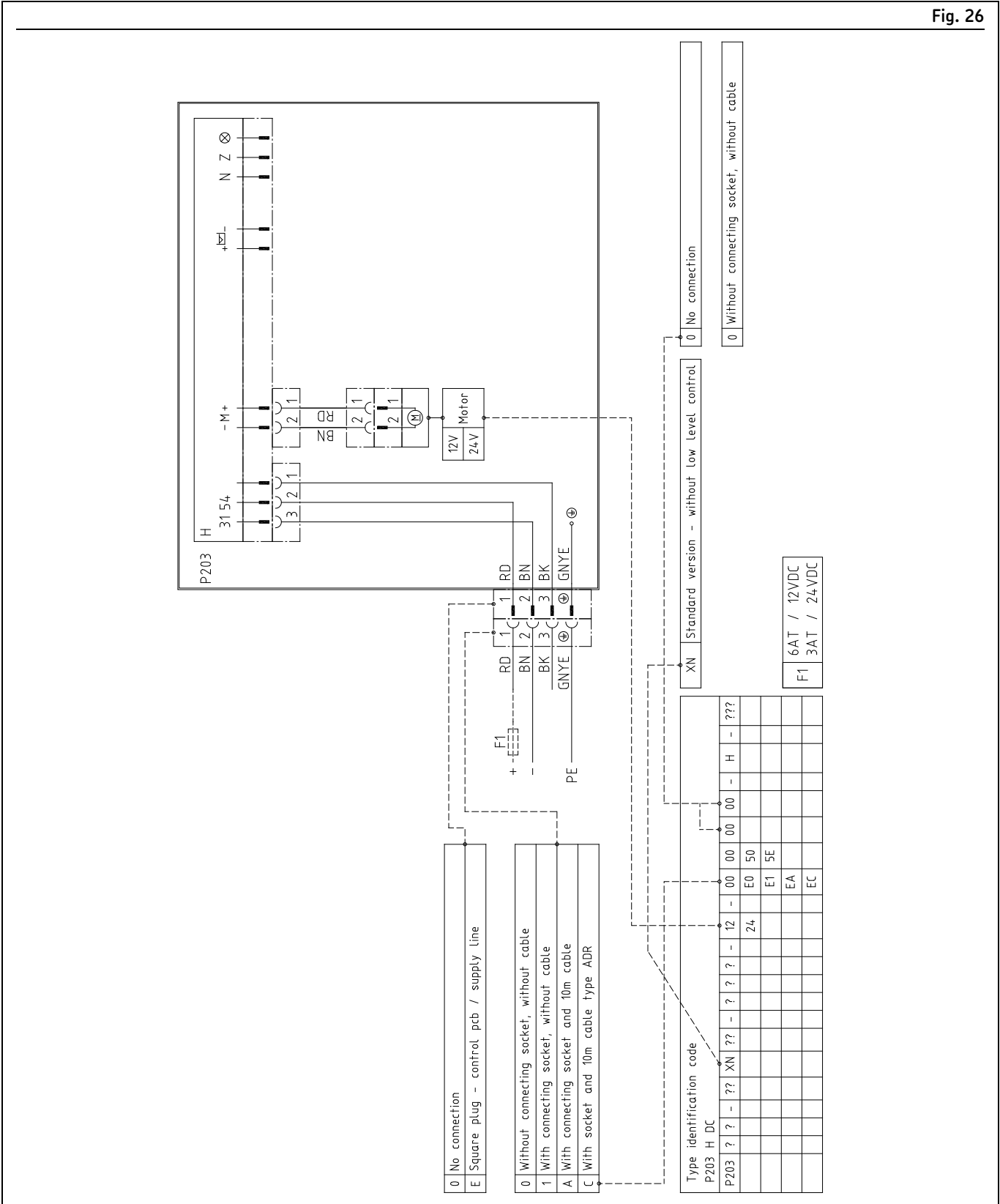

Terminal diagram 1 of 2

15.1.3 Terminal diagram P203 VDC, with control circuit board H and bayonet connector

Fig. 27

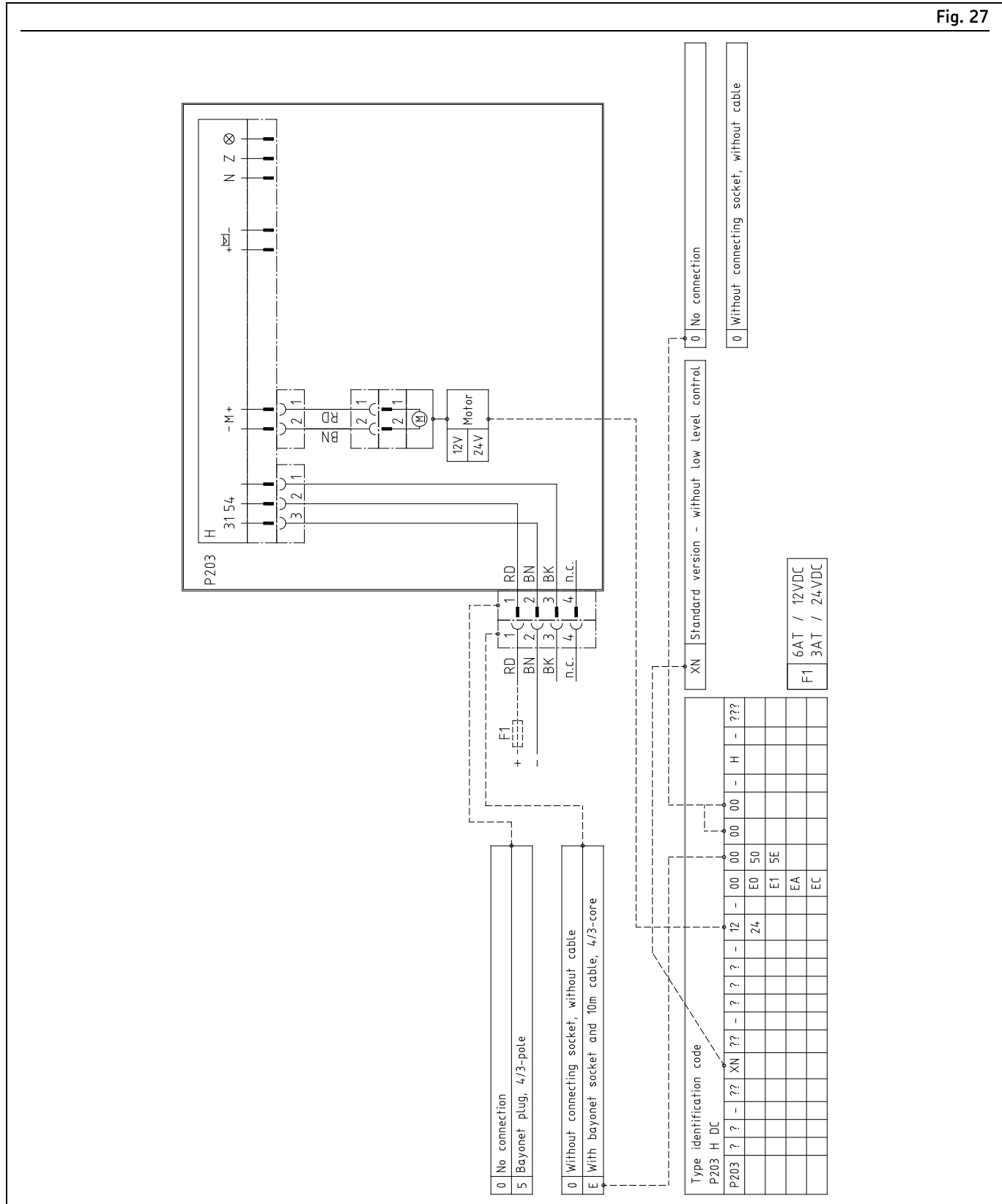

Terminal diagram 2 of 2

15.2 China RoHS Table

Table 28

部件名称 (Part Name)	有毒害物质或元素 (Hazardous substances)					
	铅	汞	镉	六价铬	多溴联苯	多溴二苯醚
	Lead (Pb)	Mercury (Hg)	Cadmium (Cd)	Hexavalent Chromium (Cr(VI))	Polybrominated biphenyls (PBB)	Polybrominated diphenyl ethers (PBDE)
用钢和黄铜加工的零件 (Components made of machining steel and brass)	X	0	0	0	0	0

本表格依据SJ/T11364的规定编制 (This table is prepared in accordance with the provisions of SJ/T 11364.)

0 :	表示该有毒有害物质在该部件所有均质材料中的含量均在GB/T 26572 规定的限量要求以下。 (Indicates that said hazardous substance contained in all of the homogeneous materials for this part is below the limit requirement of GB/T 26572.)
X :	表示该有毒有害物质至少在该部件的某一均质材料中的含量超出GB/T 26572标准规定的限量要求。 (Indicates that said hazardous substance contained in at least one of the homogeneous materials used for this part is above the limit requirement of GB/T 26572.)

skf.com/lubrication

© SKF and Lincoln are registered trademarks of the SKF Group.
™ eLube is a trademark of the SKF Group.

© SKF Group 2023
Reprint or reproduction of the contents of this information - even in part - is permitted only with
SKF's prior written consent.

PUB 951-171-028-EN 12.12.2022